

**Assembly Instructions**

**Sun Room & Sun Lounge - Clear Glazing**



**Snow Load**  
75 kg/m<sup>2</sup>  
15.4 lbs/ft<sup>2</sup>



**Wind Resistance**  
90 km/hr  
56 mi/hr

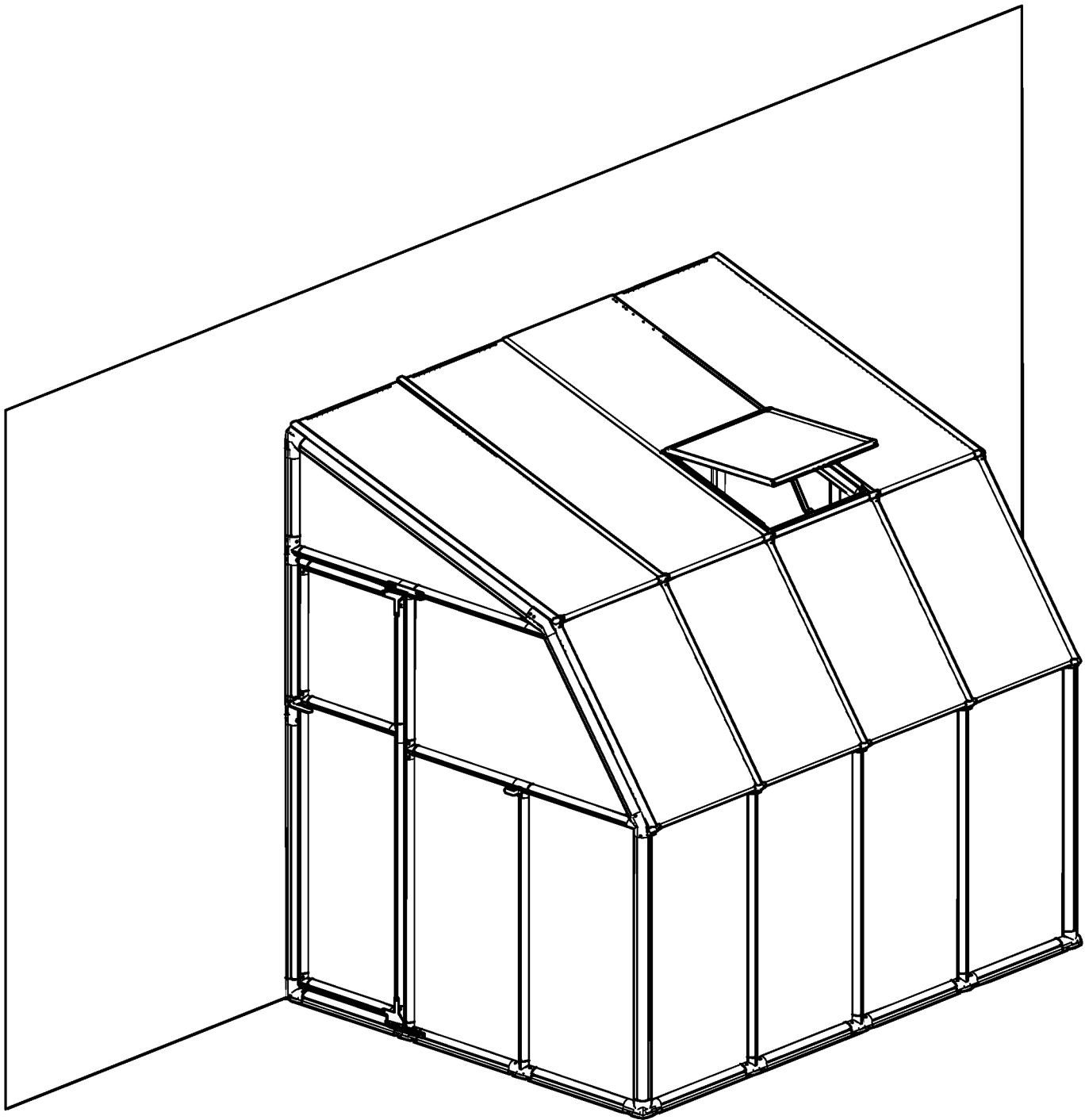

**IMPORTANT**

Please read these instructions carefully before you start to assemble this greenhouse.  
Keep these instructions in a safe place for future reference.

**GENERAL**

- Rion is not responsible for the misuse of tools or parts
- All opaque panels with the stamped words THIS SIDE OUT indicates the outside to create full UV protection. Remove plastic sticker as panels are locked in place
- All clear panels are protected by plastic film on both sides and don't have specific direction to install. Remove the plastic before installation
- The quantity of parts that required for extension is depending on purchased packages number
- This manual is suitable San Room (clear) and Sun Lounge (clear + opaque)
- Door assembly can be made from left or right

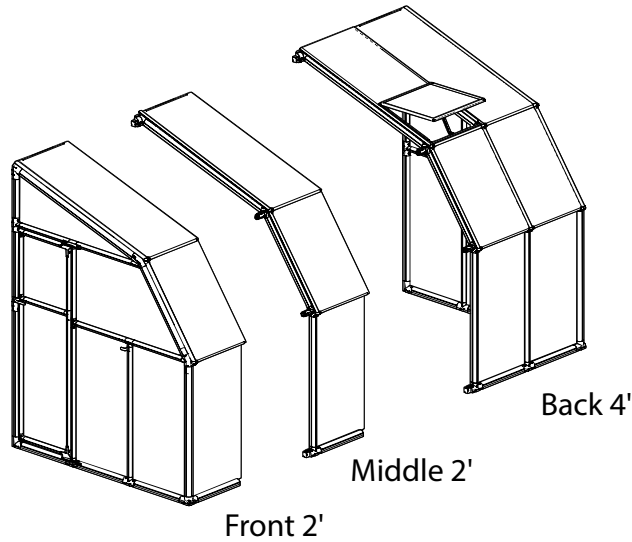

Greenhouse Sizes	Pack Qty (Front 2')	Pack Qty (Middle 2')	Pack Qty (Back 4')
6' x 6'	1		1
6' x 8'	1	1	1
6' x 10'	1	2	1
6' x 12'	1	3	1

## SAFETY ADVICE

- Rion is not responsible for the misuse of tools or parts.
- It is of utmost importance to assemble all of the parts according to the directions. Please follow them closely and do not skip any step.
- We strongly recommend using work gloves during assembly.
- If using a step ladder or power tools ensure that you follow the manufacturer's safety advice.
- If local building codes require permits or licenses make sure that they are acquired before beginning.
- Your Greenhouse should be secure by anchored to the prepared foundation using the recommended hardware.
- Do not attempt to assemble the greenhouse in windy or wet conditions.
- Dispose of all plastic bags safely keep them out of reach of small children.
- Keep children away from the assembly area.
- Do not lean against or push the greenhouse during construction.
- Do not attempt to assemble this greenhouse if you are tired, have taken drugs or alcohol or if you are prone to dizzy spell.
- When your Greenhouse is fully assembled examine it for sharp edges and trim with a razor knife if necessary.
- If you live in a hot climate, where outside temperatures exceed 46° C (115° F) in the sun or 36° C (99° F) in the shade, this may cause the temperature inside the greenhouse to exceed 55° C (131° F). Such conditions may harm your plants and will damage the greenhouse by warping structural profiles. In order to prevent damage:
  - Ensure good ventilation during hot days.
  - Make sure that the temperature inside the green house never exceeds 55° C (131° F) by providing a shading screen, such as the Shade Net (available as an accessories option).

**Note:** RION is not responsible for any damage due to high temperatures.

\* Always close roof vent in high winds.

## REQUIRED TOOLS

- GT1 - Special tool to connect pins through lined up holes. Pin Tool fix and lock profiles in place



- To assemble this product you will need the following tools (these items are not supplied)



## BEFORE ASSEMBLY

- Rion is not responsible for the misuse of tools or parts.
- Selecting a site - the greenhouse must be, positioned and fixed on a flat level surface.
- Sort the parts and check according to the contents parts list. Do not begin assembly if any parts are missing.
- If you prepare a concrete foundation do not excavate and pour concrete in frozen ground.
- We recommend that you place your Greenhouse in a spot where it will receive direct sunlight and will be protected from the wind as much as possible. The door should not face prevailing winds.

## DURING ASSEMBLY

**Step 1:** Place door hinge according to the desired side you wish to install the door, to the right or the left side of the Sun Room / Sun Lounge.

**Steps 1-4, 18, 22:** Arrange all 2D connectors with the stamped word OUT facing the outside of the greenhouse.

### Step 5:

- Make sure that the frame is perfectly straightened by measuring the diagonals and verifying that they are the same.
- Make sure that the frame is level and anchor it with screw/screw + dibble/spike (not supplied) according to the selected surface.
- The wall to which you are securing your Sun Lounge must be 90° to the foundation

**Steps 9, 10:** Walls assembly must be made gradually (1.panel 2.rofile 3.connector) according to describe method in **step #8**

**Step 27:** Make sure that the top frame is leveled with wall. Fix it using one of the two options illustrated with a screw/bolt + plugs (not supplied) according to the selected wall.

**Steps 44, 49:** Insert the rubber strip from the outside the greenhouse. Cut the remaining edges as needed.

\*Relevant only for sun room/lounge with clear panels.

## Attention:



When encountering the information icon, please refer to the relevant assembly step for additional comments and assistance.



This icon indicates that the installer should be inside the product.

## IMPORTANT

Veillez lire attentivement ces instructions avant de commencer le montage de cette serre. Conservez ces instructions en lieu sûr pour référence ultérieure.

## GÉNÉRAL

- Rion n'assume aucune responsabilité en cas de mauvaise utilisation des outils ou des pièces
- Tous les panneaux opaques tamponnés avec les mots THIS SIDE OUT indiquent l'extérieur pour créer une protection complète contre les UV. Retirez l'étiquette en plastique une fois que les panneaux sont fixés
- Tous les panneaux transparents sont protégés par des films en plastique des deux côtés et n'ont pas de sens d'installation particulière. Enlevez le plastique avant l'installation
- La quantité de pièces nécessaires pour une extension dépend du nombre de paquets achetés
- Ce manuel est adapté pour San Room (transparent) et Sun Lounge (transparent + opaque)
- L'assemblage de la porte peut se faire par la gauche ou par la droite

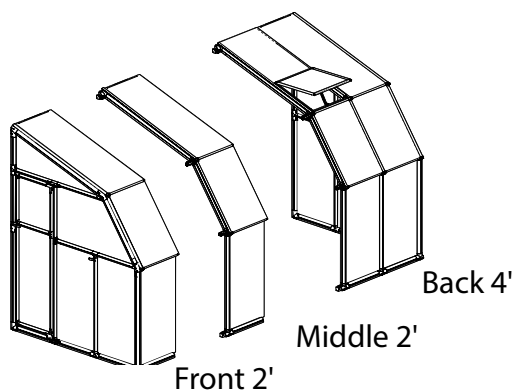

Greenhouse Sizes	Pack Qty (Front 2')	Pack Qty (Middle 2')	Pack Qty (Back 4')
6' x 6'	1		1
6' x 8'	1	1	1
6' x 10'	1	2	1
6' x 12'	1	3	1

## CONSEILS DE SÉCURITÉ

- Rion n'est pas responsable de la mauvaise utilisation des outils ou des pièces.
- Il est crucial d'assembler les pièces conformément aux instructions. Veuillez les suivre attentivement et ne sautez aucune étape.
- Nous recommandons vivement l'utilisation de gants de travail pendant le montage.
- Si vous utilisez un escabeau ou des outils électriques, assurez-vous de suivre les conseils de sécurité du fabricant.
- Si les réglementations de construction locales exigent un permis ou une licence, assurez-vous de les avoir avant de commencer.
- Votre serre doit être sécurisée en étant attachée à la fondation préparée et en utilisant le matériel recommandé
- N'essayez pas d'assembler la serre dans des conditions venteuses ou humides.
- Jetez tous les sacs plastique ou conservez-les hors de portée des jeunes enfants.
- Maintenez les enfants à distance de la zone de montage.
- Ne vous appuyez pas sur la serre et ne la poussez pas pendant la construction.
- N'essayez pas d'assembler la serre si vous êtes fatigué, avez consommé de la drogue ou de l'alcool, ou si vous êtes sujet aux étourdissements.
- Les objets chauds tels que les grills récemment utilisés, les chalumeaux, etc. ne doivent pas être conservés dans la serre. Assurez-vous qu'il n'y a aucun tuyau ou câble caché dans le sol avant d'insérer les piquets.
- Une fois votre serre complètement assemblée, examinez-la à la recherche de bords tranchants et ébarbez avec un rasoir droit le cas échéant.
- Si vous vivez dans un climat chaud, où les températures extérieures dépassent les 46°C (115°F) au soleil ou 36°C (99°F) à l'ombre, la température à l'intérieur de la serre pourrait dépasser les 55°C (131°F). De telles conditions pourraient abîmer vos plantes et endommageront la serre en déformant la structure. Afin d'empêcher tout dommage:
  - Assurez une bonne ventilation les jours chauds.
  - Assurez-vous que la température à l'intérieur de la serre ne dépasse jamais 55 °C (131 °F) en lui fournissant un écran contre le soleil, tel qu'un filet pare-soleil (disponible en tant qu'accessoire).

**Remarque:** RION ne saurait être tenu pour responsable de tout dommage dû à des températures élevées.

\* Toujours fermer les événements du toit par vent fort.

## OUTILS NÉCESSAIRES

- GT1 - Special tool to connect pins through lined up holes. Pin Tool fix and lock profiles in place
- Pour assembler ce produit, vous aurez besoin des outils suivants (non fournis)



## AVANT L'ASSEMBLAGE

- Rion n'est pas responsable de la mauvaise utilisation des outils ou des pièces.
- Choisissez un site – la serre doit être placée et fixée à une surface plate.
- Triez les pièces et vérifiez par rapport à la liste. Ne commencez pas à assembler si une quelconque pièce est manquante.
- Si vous préparez une fondation en béton, ne creusez pas et ne mettez pas de béton dans un sol gelé.
- Nous vous recommandons de placer la serre dans un lieu où elle recevra directement la lumière du soleil et où elle sera protégée du vent autant que possible. Ne pas placer la porte face aux vents dominants.

## PENDANT L'ASSEMBLAGE

**Étapes 1:** Disposez tous les connecteurs 2D avec le mot OUT vers l'extérieur de la serre.

**Étapes 1-4, 18, 22:** Arrange all 2D connectors with the stamped word OUT facing the outside of the greenhouse.

### Étapes 5:

- Assurez-vous que le cadre est parfaitement droit en mesurant les diagonales et en vérifiant qu'elles sont identiques.
- Assurez-vous que le cadre est à l'horizontale et fixez-le à l'aide de vis / vis + plantoirs / pointes (non fournis) en fonction de la surface choisie.
- Le mur auquel vous attachez votre verrière doit être à 90° par rapport à la fondation.

**Étapes 9, 10:** Le montage des murs doit être effectué progressivement (1.panneau 2.profil 3.connecteur) selon la méthode décrite en étape # 8

**Étapes 27:** Assurez-vous que le cadre supérieur est aligné avec le mur. Fixez-le à l'aide de l'une des deux options illustrées, avec une vis / boulon + bouchons (non fournis) en fonction du mur choisi.

**Étapes 44, 49:** Insérez la bande en caoutchouc depuis l'extérieur de la Serre. Coupez les bords restants, si nécessaire. \*Valable uniquement pour les verrières avec des panneaux clairs.

### Attention:



Lorsque vous voyez l'icône Information, veuillez vous référer à l'étape d'assemblage correspondante pour des commentaires et une assistance complémentaires.



Cette icône indique que l'installateur devrait se trouver à l'intérieur du produit.

**WICHTIG!**

Lesen Sie diese Aufbauanleitung sorgfältig durch, bevor Sie mit dem Zusammenbau beginnen.  
Bewahren Sie die Anleitung auf.

**INFORMATIONEN**

- RION ist nicht verantwortlich für eine fehlerhafte Benutzung von Werkzeugen oder Bauteilen.
- Die DoppelstegScheiben sind auf der UV-beständigen Seite mit einem Aufkleber "THIS SIDE OUT" versehen. Diese Seite muss zwingend nach Außen! Entfernen Sie den Aufkleber während des Einbaus der Scheibe.
- Die Acryl-Scheiben sind beidseitig mit einem Plastikfilm überzogen. Beide Seiten sind UV-Beständig. Entfernen Sie den Aufkleber während des Einbaus der Scheibe.
- Die Aufbauanleitung gilt für das RION Sun Room & Sun Lounge.
- Die Tür kann auf der rechten oder linken Hausseite montiert werden.

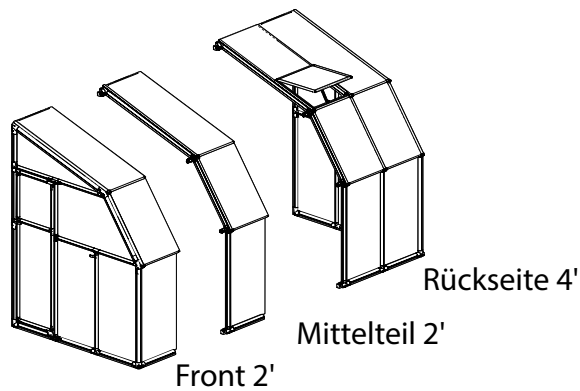

Gewächshaus Größen	Verp. Einh. (Front 2')	Verp. Einh. (Mittelteil 2')	Verp. Einh. (Rückseite 4')
Sun Room 33	1		1
Sun Room 34	1	1	1
Sun Room 35	1	2	1
Sun Room 36	1	3	1

## SICHERHEITSHINWEISE

- RION ist nicht verantwortlich für eine fehlerhafte Benutzung von Werkzeugen oder Bauteilen.
- Das Gewächshaus muss zwingend anhand der Aufbauanleitung Schritt für Schritt aufgebaut werden. Bitte lassen Sie keinen Schritt aus.
- Es ist ratsam während dem Aufbau Handschuhe zu tragen.
- Sofern Sie eine Leiter oder elektrisches Werkzeug benutzen, folgen Sie den Anweisungen des jeweiligen Herstellers.
- Erkundigen Sie sich bitte vor dem Aufbau nach eventuellen Bauvorschriften beim zuständigen Amt.
- Das Gewächshaus muss fest am Boden verankert (Beton, Holz etc.) oder mit Hilfe des empfohlenen Werkzeuges an der mitgelieferten Basis befestigt werden.
- Der Aufbau sollte nicht bei starkem Wind oder Regen erfolgen.
- Halten Sie alle Plastiktüten & Verpackungsmaterialien von Kindern fern.
- Halten Sie Kinder vom Aufbauplatz fern.
- Während des Aufbaus nicht gegen die Konstruktion lehnen.
- Sobald Sie das Gewächshaus komplett aufgebaut haben, entfernen Sie (sofern nötig) scharfe Kanten mit einem Messer oder Cutter.
- Wenn Sie in einem Land leben, in dem die Außentemperaturen in der Sonne 46° C und im Schatten 36° C betragen, können die Temperaturen im Gewächshaus 55° C überschreiten. Solche Temperaturen können Ihre Pflanzen schädigen und zum Verbiegen der Profile führen. Durch die folgenden Maßnahmen können Sie solche Schäden verhindern:
  - Achten Sie an warmen Tagen auf eine gute Belüftung.
  - Achten Sie darauf, dass die Temperatur im Gewächshaus 55° C nicht überschreitet. Sorgen Sie für einen ausreichenden Sonnenschutz, zum Beispiel mit Hilfe des RION Schattennetzes (optional erhältlich).

## HILFSMITTEL

- GT1 - spezielles RION Aufbauwerkzeug zur Befestigung der Pins in den Profilen.
- Folgende Hilfsmittel werden für den Aufbau benötigt.



## VOR DEM AUFBAU

- RION ist nicht verantwortlich für eine fehlerhafte Benutzung von Werkzeugen oder Bauteilen.
- Das Gewächshaus muss auf einer ebenen Fläche aufgebaut werden.
- Kontrollieren Sie vorab anhand der der Stücklisten die Vollständigkeit der Teile.
- Wenn Sie ein Betonfundament vorbereiten, sollten Sie dies nicht bei gefrorenem Boden tun.
- Wir empfehlen Ihnen Ihr Gewächshaus so zu platzieren, dass es der direkten Sonneneinstrahlung ausgesetzt und so weit wie möglich vor Winden geschützt ist. Richten Sie die Türen und Fenster so aus, dass diese nicht gegen den Wind stehen.

## AUFBAUHINWEISE

**Schritt 1:** Platzieren Sie das Türscharnier entsprechend der gewünschten Seite, auf der Sie die Tür installieren möchten, rechts oder links von dem Sonnenraum/ Sonnenlounge

**Schritt 1-4, 18, 22:** Platzieren Sie alle 2D-Verbinder mit dem gestempelten Wort "OUT" nach Außen!

### Schritt 5:

- Stellen Sie sicher, dass sich das Haus im Winkel befindet, indem Sie die Diagonalen messen. X=Y
- Sofern Sie nicht das RION Fundament bestellt haben: Stellen Sie sicher das das Haus in der Waage steht. Befestigen Sie den Bodenrahmen mit Dübeln, Schrauben, Erdankern(nicht im Lieferumfang enthalten) an Ihrem bestehenden Fundament.

**Schritt 9, 10:** Der Aufbau der Seitenwände muss in den nachstehenden Schritten erfolgen: (1. Doppelstegplatte, 2. Profile, 3. Pins), siehe **Schritt 8**.

**Schritt 27:** Befestigen Sie den Wandanschluss mit Dübeln, Schrauben(nicht im Lieferumfang enthalten) an Ihrer Wand.

**Schritt 44, 49:** Befestigen Sie den mitgelieferten Gummi von Außen an den Scheiben. Schneiden Sie sich diesen nach Bedarf zurecht.

\*Nur nötig bei Modellen mit Acryl-Scheiben.

## ACHTUNG:



Dieses Symbol verweist auf zusätzliche Information des jeweiligen Aufbauschnittes unter AUFBAUHINWEISE.



Bei diesem Aufbauschnitt sollte sich der Monteur innerhalb des Hauses befinden.

ES

## IMPORTANTE

Por favor, lea estas instrucciones cuidadosamente antes de comenzar a montar este invernadero. Guarde estas instrucciones en un lugar seguro para consultarlo en el futuro.

## GENERAL

- Rion no es responsable de la mala utilización de herramientas o piezas.
- Usted puede adquirir un Paquete mediano de Hobby Gardener para ampliar el tamaño de su invernadero y satisfacer sus necesidades.
- Los dibujos de este manual están diseñados para un invernadero de 6' x 6' (1,8 x 1,8 metros) que consiste en una unidad frontal y una unidad posterior. Por favor, tenga en cuenta que la cantidad de piezas necesarias para un invernadero de mayor tamaño se enumera en los pasos de abajo, dependiendo de la cantidad de paquetes medianos que haya adquirido.
- Todos los panales con las palabras impresas ESTE LADO FUERA (THIS SIDE OUT) deben mirar hacia fuera para crear una protección total contra rayos UV. Retire la pegatina de plástico según va fijando los paneles en su lugar.
- Si ha adquirido la Base de resina de invernadero Rion siga las instrucciones de montaje en el envase. La Base modular de invernadero se puede colocar en un agujero excavado o en el suelo. En cualquier caso, usted necesitará suficiente grava, tierra u otro material adecuado para rellenar la base (vea la tabla de abajo). Se incluyen todas las herramientas necesarias..

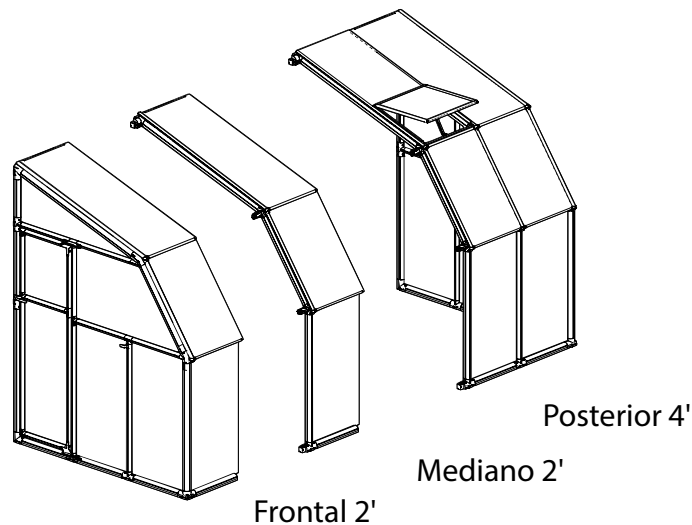

Tamaños de invernadero	Cdad. del paquete (Frontal 2')	Cdad. del paquete (Mediano 2')	Cdad. del paquete (Posterior 4')
6' x 6'	1		1
6' x 8'	1	1	1
6' x 10'	1	2	1
6' x 12'	1	3	1

## AVISO DE SEGURIDAD

- Rion no es responsable de la mala utilización de herramientas o piezas.
- Es de suma importancia montar todas las piezas siguiendo las instrucciones. Por favor, sígalas atentamente y no omita ningún paso.
- Recomendamos encarecidamente utilizar guantes de trabajo durante el montaje.
- Si utiliza una escalera o herramientas eléctricas, asegúrese de seguir los consejos de seguridad del fabricante.
- Si las normas de construcción locales requieren permisos o licencias, asegúrese de adquirirlos antes de comenzar.
- Su invernadero debería fijarse anclándolo a la base preparada usando las herramientas recomendadas.
- No intente montar el invernadero bajo condiciones de viento o de lluvia.
- Tire todas las bolsas de plástico y manténgalas fuera del alcance de los niños
- Mantenga a los niños fuera del área de montaje.
- No se apoye o empuje el invernadero durante su construcción.
- No intente montar este invernadero si está cansado, ha tomado drogas o alcohol o si es propenso a mareos.
- Los objetos calientes como parrillas usadas recientemente, sopletes, etc., no deben guardarse en el invernadero. Asegúrese de que no hay cables o tubos ocultos en el suelo antes de insertar las clavijas.
- Cuando su invernadero esté montado por completo, examínelo buscando filos cortantes y recórtelos con una navaja si es necesario.
- Si vive en un clima cálido donde las temperaturas exteriores exceden los 46° C (115° F) al sol o los 36° C (99° F) a la sombra, esto podría hacer que la temperatura en el interior del invernadero supere los 55° C (131° F). Dichas condiciones podrían dañar sus plantas y su invernadero deformando los perfiles estructurales. Para evitar daños:
  - Asegúrese de que hay una buena ventilación durante días calurosos.
  - Asegúrese de que la temperatura en el interior del invernadero no supere nunca los 55° C (131° F) proporcionándole una sombra como Shade Net (disponible como accesorio).

**Nota:** RION no es responsable por cualquier daño debido a altas temperaturas.

\* Cierre siempre el respiradero del techo cuando haga mucho viento.

## HERRAMIENTAS NECESARIAS

- GT1 - Herramienta especial para conectar pernos a través de los orificios alineados. Esta herramienta fija y bloquea los perfiles en su lugar.
- Para montar este producto necesitará las siguientes herramientas (no suministradas)



## ANTES DEL MONTAJE

- Rion no es responsable de la mala utilización de herramientas o piezas.
- Seleccione un lugar. El invernadero debe estar situado y fijado en una superficie llana.
- Clasifique las piezas y compruébelas según la lista del contenido. No comience el montaje si falta alguna pieza.
- Si prepara una base de hormigón no excave y vierta hormigón sobre suelo congelado.
- Le recomendamos que coloque su invernadero en un punto donde reciba luz directa del sol y esté protegido del viento lo máximo posible. La puerta no debería estar de cara a vientos predominantes.

## DURANTE EL MONTAJE

**Paso 1:** Coloque la bisagra de acuerdo al lado en el que usted desee instalar la puerta, hacia la derecha o izquierda del Solario / Solana.

**Pasos 1-4, 18, 22:** disponga todos los conectores 2D con la palabra inscrita OUT mirando al exterior del invernadero.

**Paso 5:**

- Asegúrese de que el marco está perfectamente derecho midiendo las diagonales y verificando que son iguales.
- Asegúrese de que el marco está nivelado y áncelo con tornillo / tornillo + plantador / punta (no suministrados) según la superficie seleccionada.
- La pared a la que fije su Sun Lounge debe tener 90° con respecto a la base.

**Pasos 9, 10:** el montaje de las paredes se debe hacer de forma gradual (1. panel, 2. perfil, 3. conector) de acuerdo al método descrito en el **paso n.º 8**

**Paso 27:** asegúrese de que el marco superior está nivelado con la pared. Fíjelo usando una de las dos opciones ilustradas con un tornillo / perno + tapones (no suministrados) según la pared seleccionada

**Pasos 44, 49:** inserte la tira de goma desde el exterior del invernadero. Corte los filos restantes según sea necesario.

\* Solamente permitente para Sun room/Sun lounge con paneles transparentes

Atención:



cuando encuentre el icono de información, por favor, consulte el paso de montaje pertinente para obtener comentarios adicionales y asistencia.



Este icono indica que el instalador debería estar dentro del producto.

NN

## VIKTIG

Les disse instruksjonene nøye før du setter sammen drivhuset.  
Plasser instruksjonene på et trygt sted for fremtidig referanse.

## GENERAL

- Rion tar ikke ansvar for misbruk av verktøy eller deler.
- Alle ugjennomsiktige paneler med ordene 'THIS SIDE OUT' hentyder at skriftsiden skal vendes utover for å beskytte mot UV-strålinger. Fjern plastklistremerkene etter panelene har blitt låst på plass.
- Alle gjennomsiktige paneler beskyttes av en plastfilm på begge sider og behøver ikke å installeres på nå spesifikt vis. Fjern plastikken før du monterer de på plass.
- Antall deler som trengs til utviding er avhengig av hvor mange pakker som ble kjøpt.
- Denne bruksanvisningen kan brukes til San Room (gjennomsiktig) og Sun Lounge (gjennomsiktig + ugjennomsiktig).
- Døren kan monteres på venstre eller høyre side.

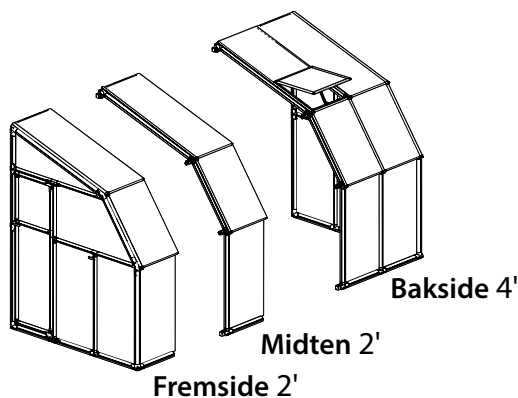

Drivhusstørrelser	Pakkeant (Fremside 2')	Pakkeant (Midten 2')	Pakkeant (Bakside 4')
6' x 6'	1		1
6' x 8'	1	1	1
6' x 10'	1	2	1
6' x 12'	1	3	1

## SIKKERHETSTIPS

- Rion skal ikke holdes ansvarlig for misbruk av verktøy eller deler.
- Det er viktig å montere alle delene i henhold til instruksjonene. Følg dem nøye og ikke hopp over steg.
- Vi anbefaler sterk å bruke arbeidshansker under montering.
- Dersom man bruker en stige eller elektriske verktøy må du forsikre deg om at du følger fabrikantens sikkerhetsinstruksjoner
- Dersom lokale byggekoder krever tillatelser eller lisenser må du passe på å få disse før du begynner.
- Ditt drivhus bør sikres med ankere til grunnmuren ved å bruke anbefalt verktøy.
- Ikke forsøk å montere drivhuset i vind eller våte forhold.
- Kast alle plastikkposene og hold dem borte fra små barn.
- Hold barna unna monteringsområdet.
- Ikke len mot eller dytt drivhuset under montering.
- Ikke forsøk å montere drivhuset dersom du er trett, har tatt narkotika eller alkohol eller om du har tendenser til å bli svimmel.
- Varme elementer som griller, flammekastere osv. må ikke lagres i drivhuset. Forsikre at det ikke er borgjemte rør eller kabler på bakken før du setter i polene.
- Når drivhuset er ferdig montert må du undersøke for skarpe kanter og trimme med en barberkniv om nødvendig.
- Dersom du bort i et varmt klima hvor utendørstemperaturer overstiger 46° C (115° F) i solen eller 36° C (99° F) i skyggen da dette kan forårsake temperaturer i drivhuset på over 55° C (131° F). Slike forhold kan skade plantene og vil skade drivhuset ved å bøye strukturprofilene. For å forhindre skade:
  - Forsikre god ventilasjon på varme dager.
  - Pass på at temperaturen inni drivhuset ikke overstiger 55° C (131° F) ved å gi det en skyggebelagt skjerm som Skyggenettet (tilgjengelig som et alternativt tilbehør).

**Merk:** Rion er ikke ansvarlig for skade forårsaket av høye temperaturer.

\*Alltid lukk takluken ved sterk vind.

## PÅKREVDE VERKTØY

- GT1 - Spesialverktøy for å koble sammen poler gjennom opplinjede hull. Pin verktøy fiks og lås profilene på plass.
- For å montere produktet vil du trenge følgende verktøy (følgende enheter følger ikke med).

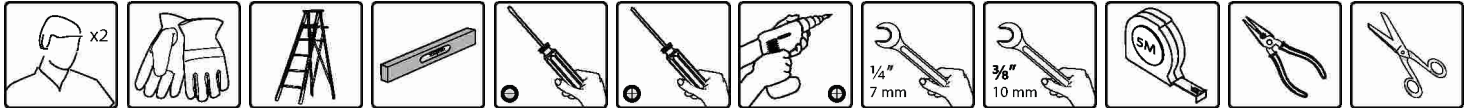

## FØR MONTERING

- Rion skal ikke holder ansvarlig for misbruk av verktøy eller deler.
- Det å velge et sted - drivhuset må være posisjonert og fast på en flat overflate.
- Sorter deler og sjekk i henhold til innholdslisten for deler. Ikke begynn monteringen dersom du mangler deler.
- Dersom du forbereder en betinggrunn ikke grav og hell beting ned i frossen grunn.
- Vi anbefaler at du plasserer drivhuset hvor det vil få sollys og beskyttes fra vinden så mye som mulig. Døren må ikke være vendt mot vinden.

## UNDER MONTERING

**Step 1:** Sett dørhengsel i henhold til ønsket side du vil installere døren, til høyere eller til venstre side av verandaen.

**Steps 1-4, 18, 22:** Organiser alle 2D tilkoblinger med samme stemplede ord UT utover som utsiden på drivhuset.

### Step 5:

- Pass på at rammen er helt rett ved å måle diagonalene og verifisere at de er like.
- Veggen som du sikrer til solrommet må være 90 grader på grunnmuren.

**Steps 9, 10:** Montering av veggene må gjøres gradvis (1 panel, 2 rofil 3. tilkobler) i henhold for å beskrive metoden i **sted #8**.

**Step 27:** Pass på at topprammen er jevn med veggen. Fiks det ved å bruk den av de to alternativene illustrert med en skrue/bolt + plugg (medfølger ikke) i henhold til valgt vegg.

**Steps 44, 49:** Installer gummistripen fra utsiden på drivhuset. Kutt de gjenværende kantene ved behov.

- Relevant kun for solrom med klare paneler.

## Merk:



Når du ser informasjonsikonet må du henvise til det relevante monteringssteget for tilleggskommentarer og assistanse.



Dette ikonet indikerer at installasjonen er inni produktet.

KR

## 주의사항

온실을 조립하기전에 매뉴얼을 완전히 숙지하시기 바랍니다.  
 향후 필요할경우 매뉴얼은 안전한곳에 보관하셔서 참고하세요.

## 일반사항

- 당사는 설치시 고객의 실수로 발생한것에 대해서는 책임지지 않습니다.
- 온실의 길이를 더 늘리고자 할경우 하비가드너 중간박스를 추가로 구매하시면 됩니다.
- 매뉴얼에 나오는 온실은 262cm x 200.5cm(길이 x 폭) 사이즈이며 앞,중간,뒤 각각 1박스 포함되어 있습니다. 아래표를 참고하시어 더 늘리고자 할때는 중간박스 수량을 체크하시기 바랍니다.
- 모든 판재위에는 THIS SIDE OUT 이라는 문구가 있으며 설치시 밖으로 향하게 해야 됩니다 이유는 UV 보호처리가 되었습니다. 판재를 고정한후에는 스티커를 제거 바랍니다.
- 리온 온실을 조립하고 난후 지면과 닿은 베이스 프레임부분에 충분한 자갈이나 흙 으로 채워주면 좋습니다.  
 - 모든 필요한 자재는 포함되어 있습니다.

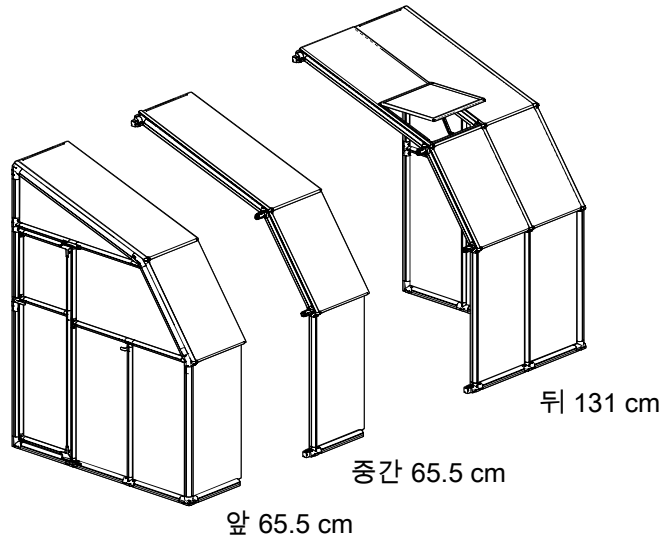

온실 규격 (길이 x 폭 x 높이)	박스수량 (앞 65.5 cm)	박스수량 (중간 65.5 cm)	박스수량 (뒤 131 cm)
196.5 x 200.5 x 247cm	1		1
262 x 200.5 x 247cm	1	1	1
327.5 x 200.5 x 247cm	1	2	1
393 x 200.5 x 247cm	1	3	1
458.5 x 200.5 x 247cm	1	4	1
524 x 200.5 x 247cm	1	5	1
589.5 x 200.5 x 247cm	1	6	1

## 안전주의사항

- 당사는 고객의 부주의나 실수로 발생하는부분에 대해서는 책임을 지지 않습니다.
- 메뉴얼에 따라 모든자재가 조립되어지는것이 가장 중요합니다. 건너뛰지 마시고 매 조립단계마다 주의를 기울여서 하시기 바랍니다.
- 제품을 조립하는동안 필히 장갑을 착용할것을 권고합니다.
- 사다리 또는 전동공구를 사용하실경우 제조사의 안전규칙을 준수하기 바랍니다.
- 시공전에 승인 또는 허가가 필요한지 미리 알아보시기 바랍니다.
- 온실 시공후 지면에 단단히 고정되어야 합니다.
- 바람이 많이불거나 습한날씨에는 온실시공을 하지말것을 권장합니다.
- 모든 자재는 아이들손에 닿지 않게 잘 보관하시기 바랍니다.
- 온실시공중 주변에 아이들이 접근하지 못하도록 하세요.
- 시공이 완료되기전에는 온실에 기대거나 밀지 마세요.
- 피곤하거나 신체상태가 좋지 않을경우 시공을 하지 마세요.
- 최근사용한 그릴이나 토치램프 등 뜨거운 제품을 온실안에 보관하지 마세요. 지면에 말뚝을 고정하기전에 파이프 또는 케이블 유무를 먼저 확인하시기 바랍니다.
- 시공이 거의 마무리될쯤 날카로운 모서리 부분은 필요할경우 칼을 이용하여 다듬어 주시기 바랍니다.

주의: 당사는 고온에 의하여 발생하는 문제는 책임지지 않습니다.

\* 강풍이 불때는 지붕환기창을 항상 닫아 주세요.

## 필요공구

- GT1 :특별제작된 도구로서 핀을 끼워서 프로파일과 각 커넥터를 고정.
- 조립시 필요한 아래 그림도구들은 제공되지 않습니다.



## 조립전 주의사항

- 자재 및 공구를 잘못사용하여 발생하는부분에 대해서는 책임을 지지 않습니다.
- 장소선택: 온실은 평평한 지면(바닥)위에 설치되어야 합니다.
- 모든자재를 체크후 어떤자재라도 모자랄경우 조립하지 마십시오.
- 기초작업으로 결빙상태의 땅을 파서 콘크리트를 부어 진행하지 마세요.
- 온실은 가능한 많은 햇빛을 바로 받을수있고 바람으로부터 보호할수있는 그런 장소에 설치할것을 권장 합니다. 문은 바람과 마주하지 않도록 하십시오.

## 조립과정시 유의사항

- 스텝 1: Sun Room / Sun Lounge의 오른쪽 또는 왼쪽에 도어 설치를 원하는 면에 따라 도어 힌지를 배치하십시오.
- 스텝 1~4, 18, 22: 2D 커넥터들을 인쇄되어있는 부분이 온실 밖을 향하게 정렬합니다.
- 스텝 5:
  - \* 프레임이 수직 및 대각선 길이가 동일하게 맞도록 맞춥니다.
  - \* 프레임이 수직과 수평이 평행하게 하여 스크류가 잘 맞도록 정렬합니다.
  - \* 선라운지 온실은 벽과 지면이 직각 90도가 되도록 해야 됩니다.
- 스텝 9,10: 벽면시공은 조립과정에 의해서 판재, 프로파일, 커넥터가 순서대로 조립이 진행되어야 합니다.
- 스텝 27: 시공할려는 벽에 지붕 프레임을 수평이 되게 한다음 그림을 보시면 두개의 옵션중 하나를 스크류와 볼트로 고정합니다.
- 스텝 44, 49: 온실 밖에서 고무실을 판재와 프레임 사이에 간단한 도구(GT1) 이용하여 끼워 넣습니다.

## 주의:







이러한 아이콘이 나오면 적절한 조립과정 전후상황을 체크 하세요.



이러한 아이콘이 나오면 작업자는 온실안에 있어야 합니다.

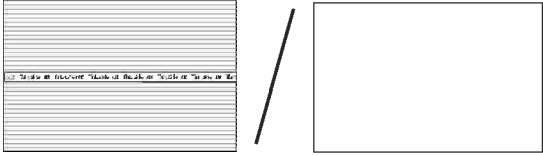
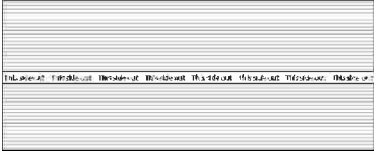
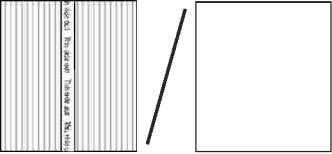
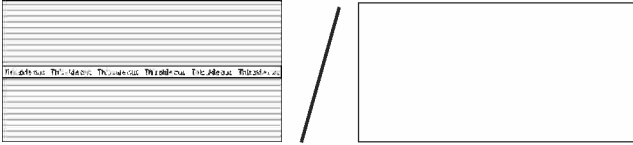

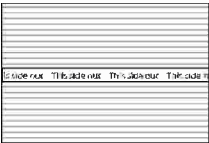
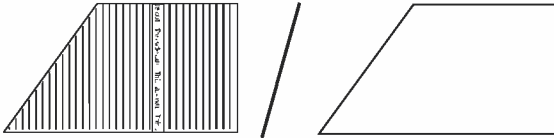

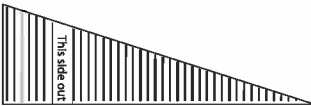



# Contents

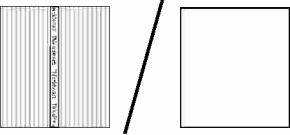
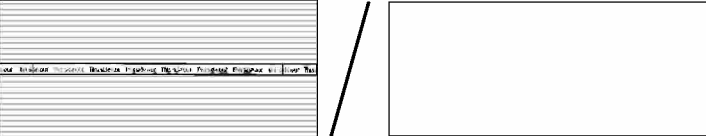

Item		Front	Back	Middle
PN55		1	2	1
PN57		1	1	1
7628 / PN53		0	1	0
7539 / PN1		3	5	1
586		0	1	0
7630		0	1	0
7619 / PN51		0	1	0
7620 / PN51		1	0	0
7617		0	1	0
7618		1	0	0

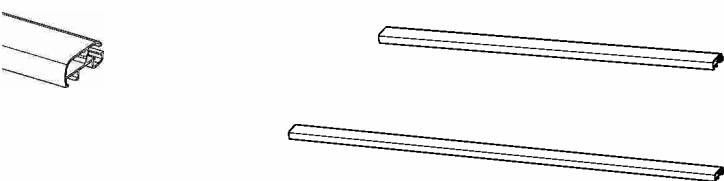
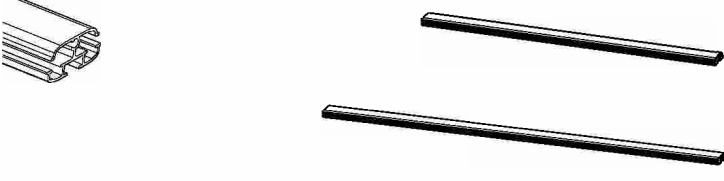
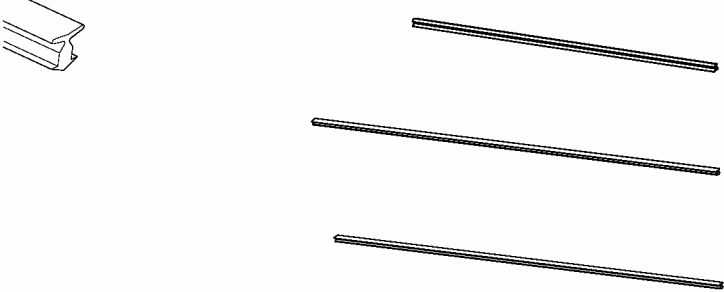





# Contents

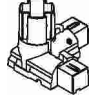
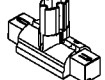
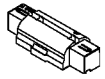
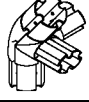
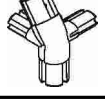
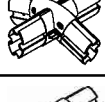

Item		Front	Back	Middle
7616 / PN128		1		
7544 / PN127		1		
72		2		
73			2	
74			4	2
7612		1	1	
7611		1	1	
7613			2	1
7614			2	1
7608		1	3	1
7610			2	1
7609		1	1	
7552			4	2
7552F		2		
DSN		1		

# Contents

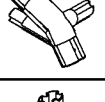
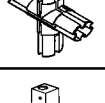
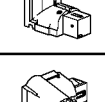
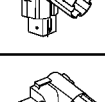
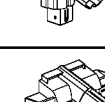
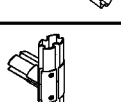

Item		Front	Back	Middle
981		1	2	1
PIN1		160	160	30
01		1	1	
2D		3	6	1
15		1		
53			1	
75		1		
51			4	2
76			1	
71		1		
10			1	
11		1	1	
12		1		
13			1	
14			2	1
09		4	2	
18		4		



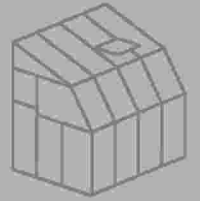

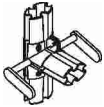
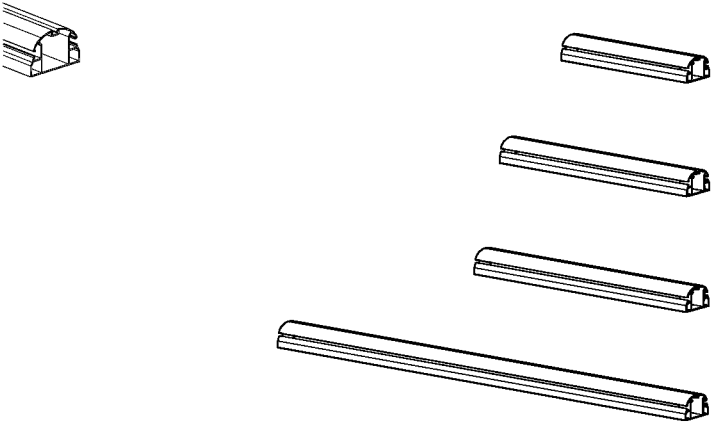
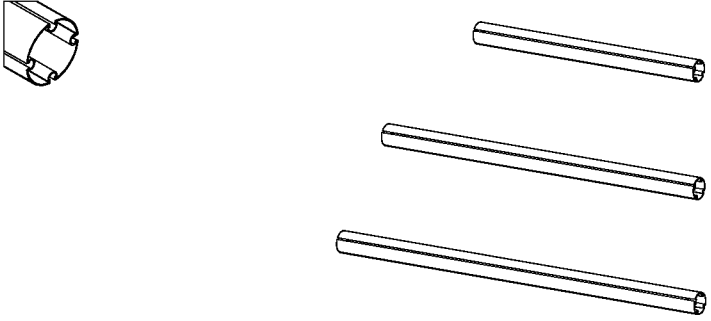
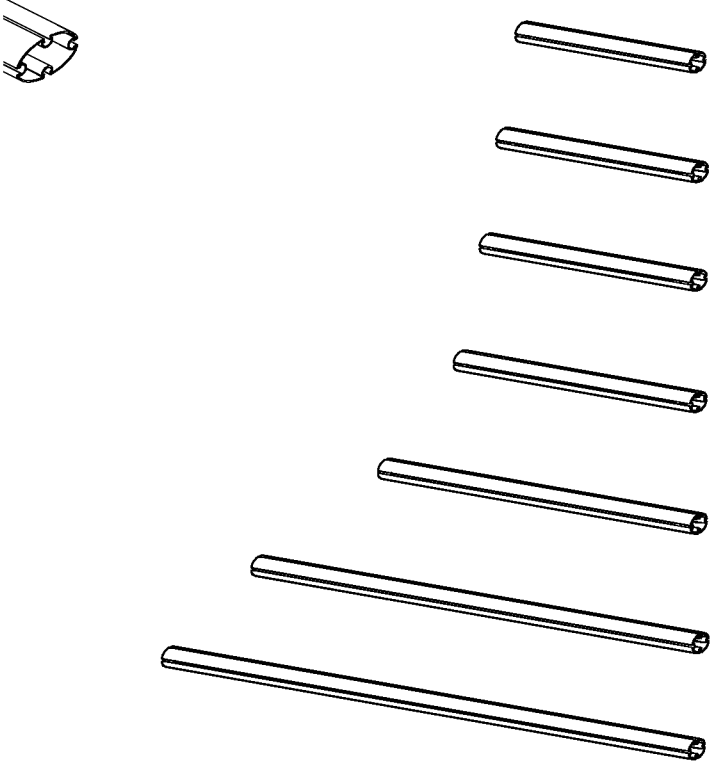





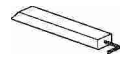





# Contents



Item		Front	Back	Middle
Door 33		1		
B11		1	1	
B2		5	7	2
B12		1	1	
B1		1	1	
R1		1	1	
R11		1	1	
R10		1	1	
E100		3		
E102		2		
E2		5	8	2
E13		2	2	
E15			2	1
E1		4	4	1
E16			2	1

# Contents













Item		Front	Back	Middle
SR1		1		
GT1		1	1	
7216		1		
7215		1		
7217		2		
7273		1		
7224		8		
4016		2		
466		8	2	
7279		2		
425		2		
7281		2		
4043		3	9	3
22			1	
99			1	
BC1		10	2	2
GF*	 	2	1	2

\*only for clear Sun Room / Sun Lounge

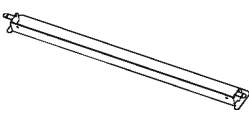
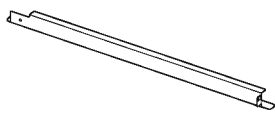
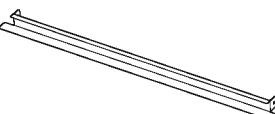
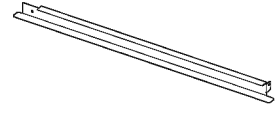
# Contents



Item		Front	Back	Middle
992			2	
991			1	
989			1	
411			2	
4008			4	
7441			1	
7536			1	
7534			1	
7535			1	
7533			1	
7220			1	
SF			2	
465			4	
422			4	

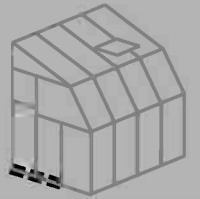

**1** **i**

item		Qty.
B2		2
SR1		1
2D		1

item		Qty.
7217		1
466		2
7224		2

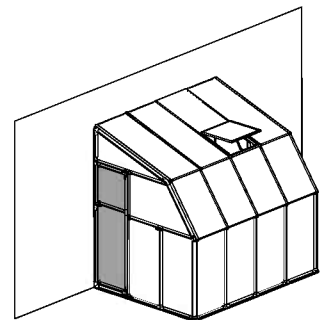
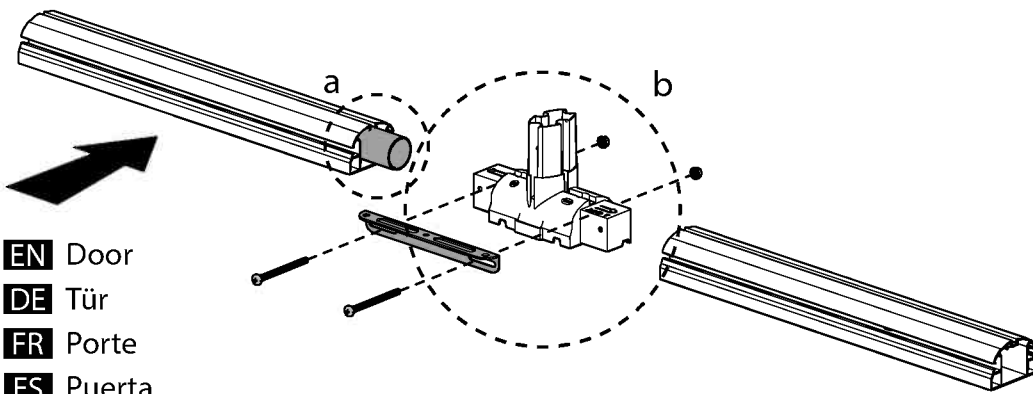
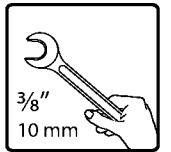
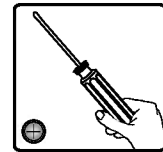



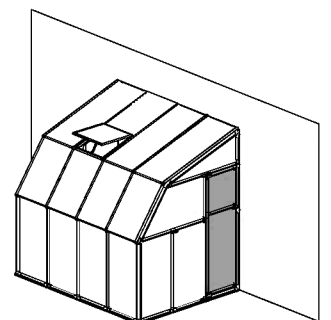
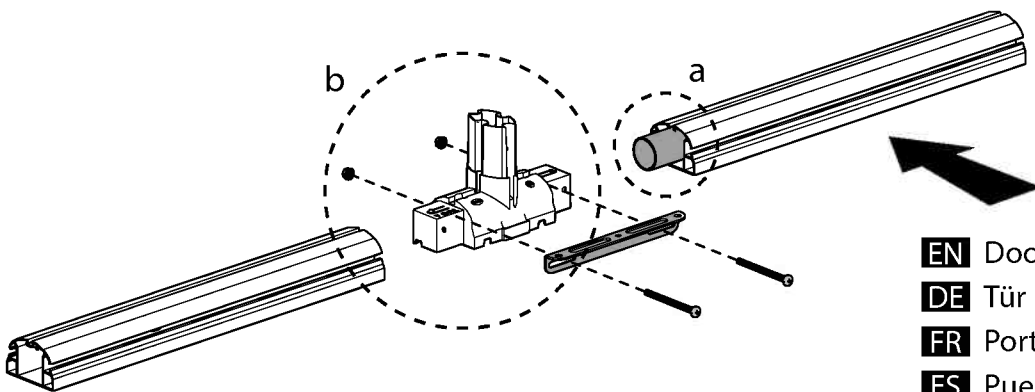
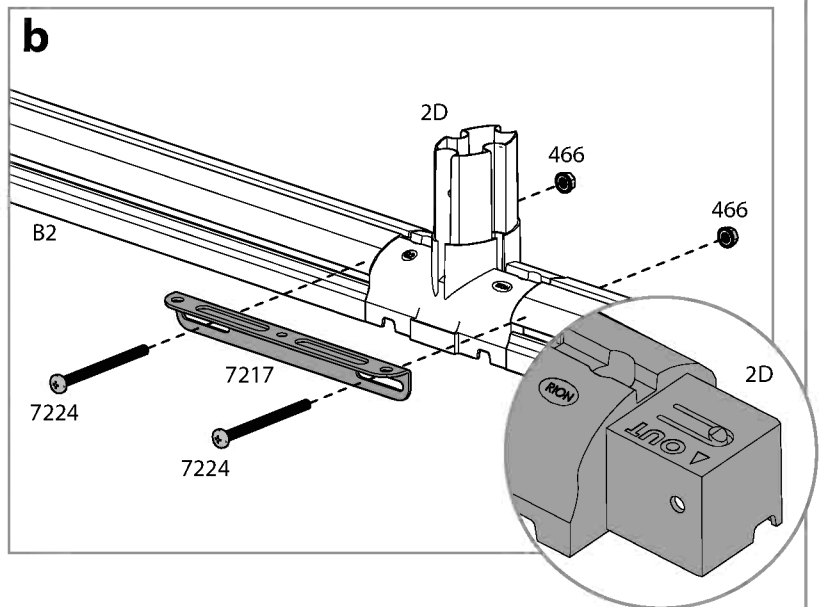
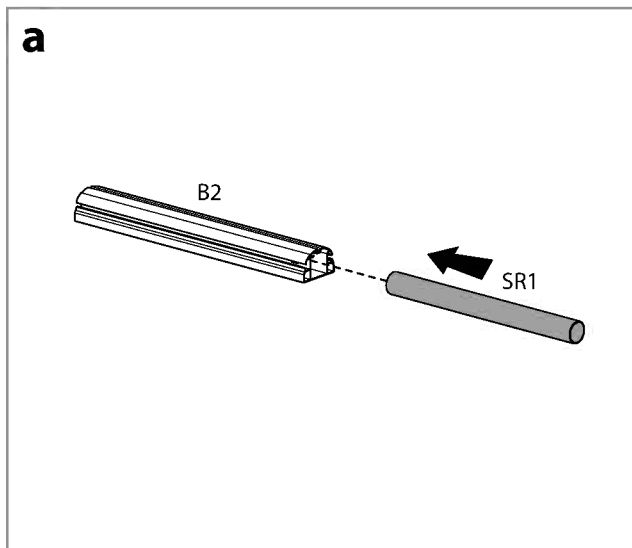

**EN** Door  
**DE** Tür  
**FR** Porte  
**ES** Puerta

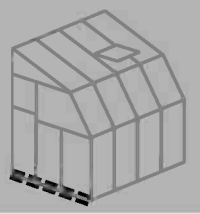

**EN** Door  
**DE** Tür  
**FR** Porte  
**ES** Puerta

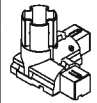

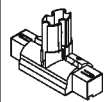
Item		Qty.	Item		Qty.
B2		1	11		1
01		1	pin1		8
2D		1			

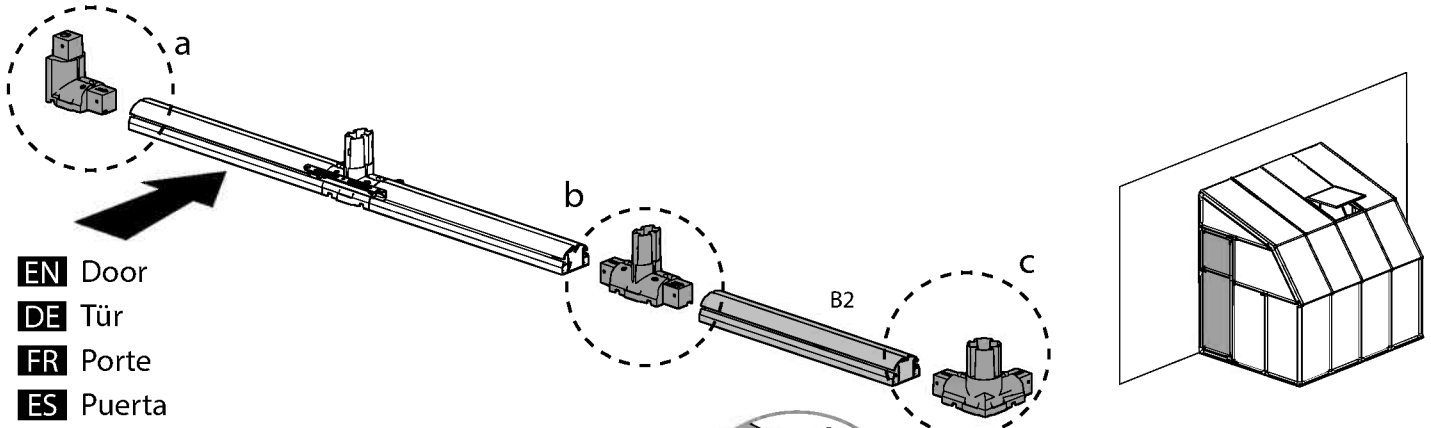
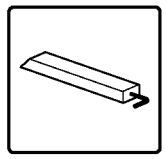

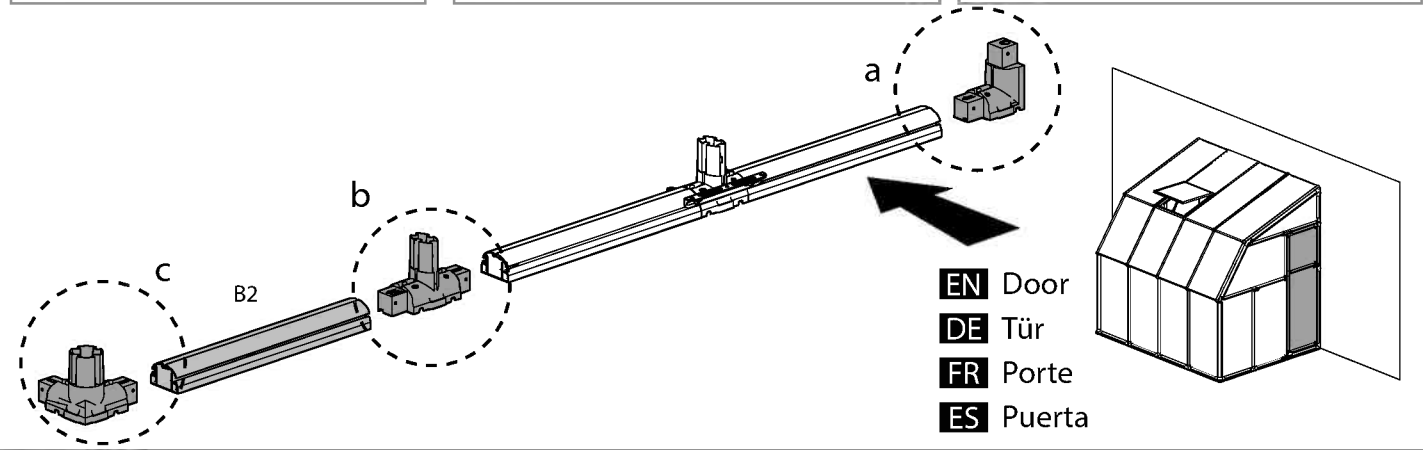
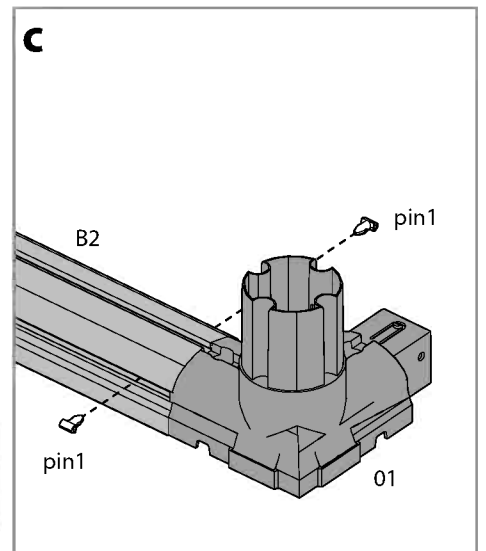
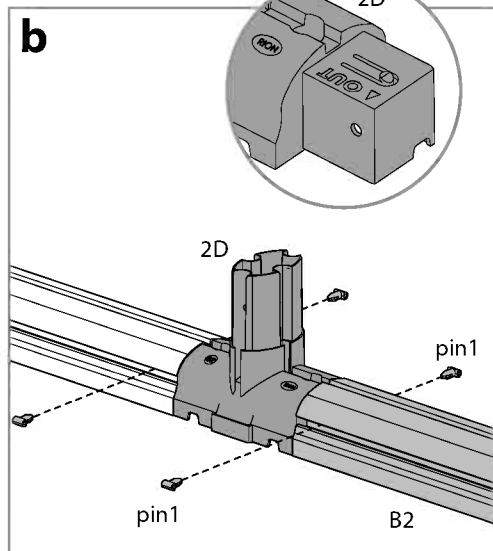
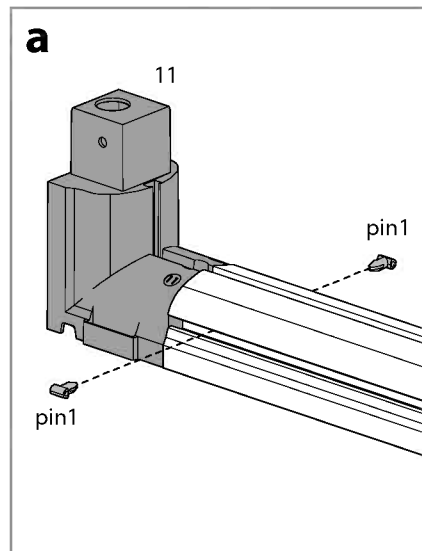

- EN** Door
- DE** Tür
- FR** Porte
- ES** Puerta

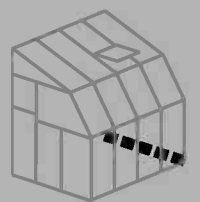

- EN** Door
- DE** Tür
- FR** Porte
- ES** Puerta

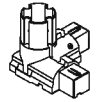
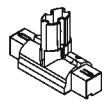

Item		Qty.
B2		3
01		1
2D		2

Item		Qty.
11		1
pin1		12

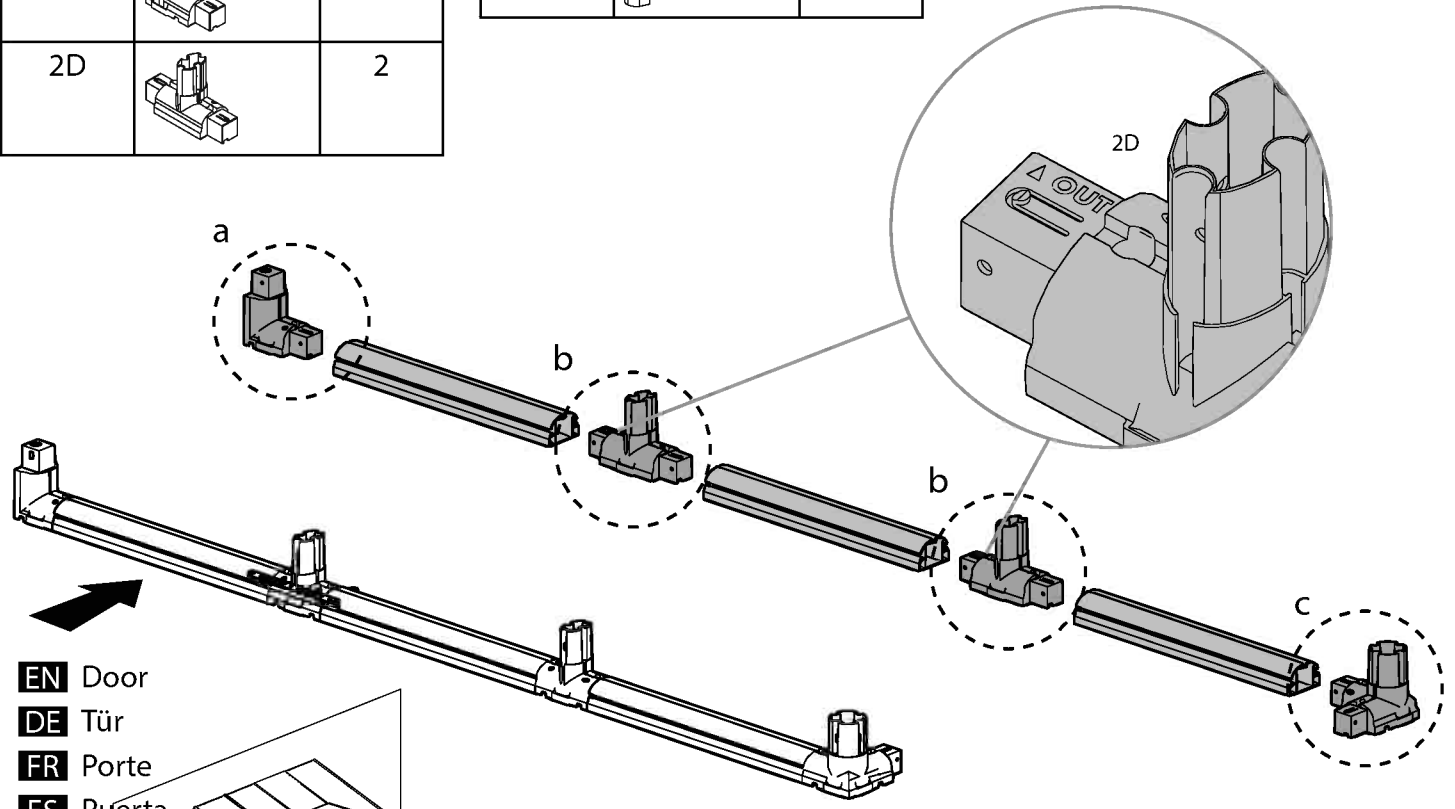
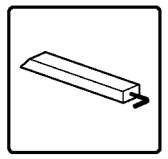

- EN** Door
- DE** Tür
- FR** Porte
- ES** Puerta

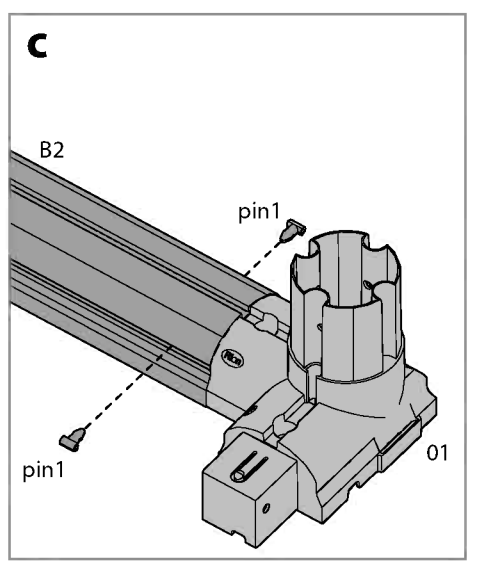
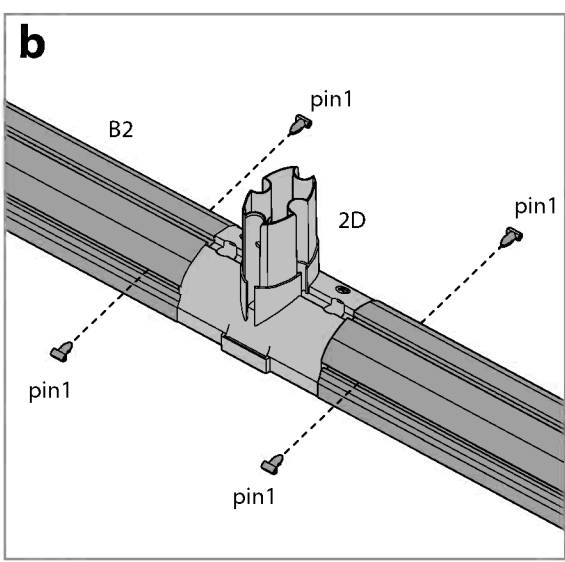
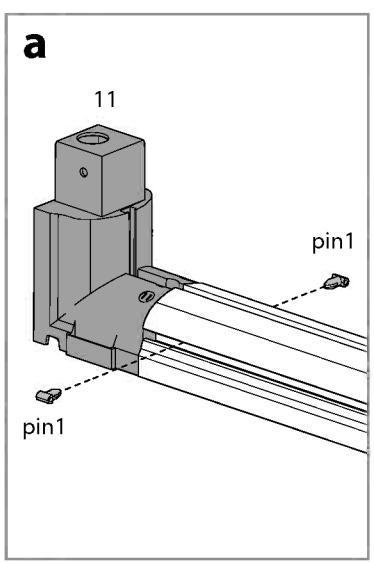
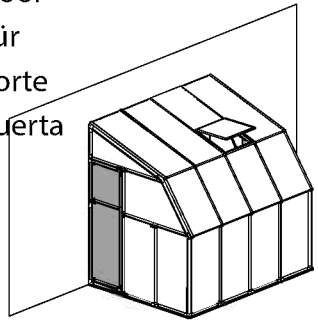

4

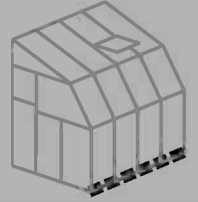

Item		Qty.
B2		4
2D		3
pin1		16

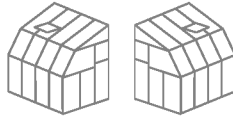

6'x8' = 4xB2

6'x10' = 5xB2

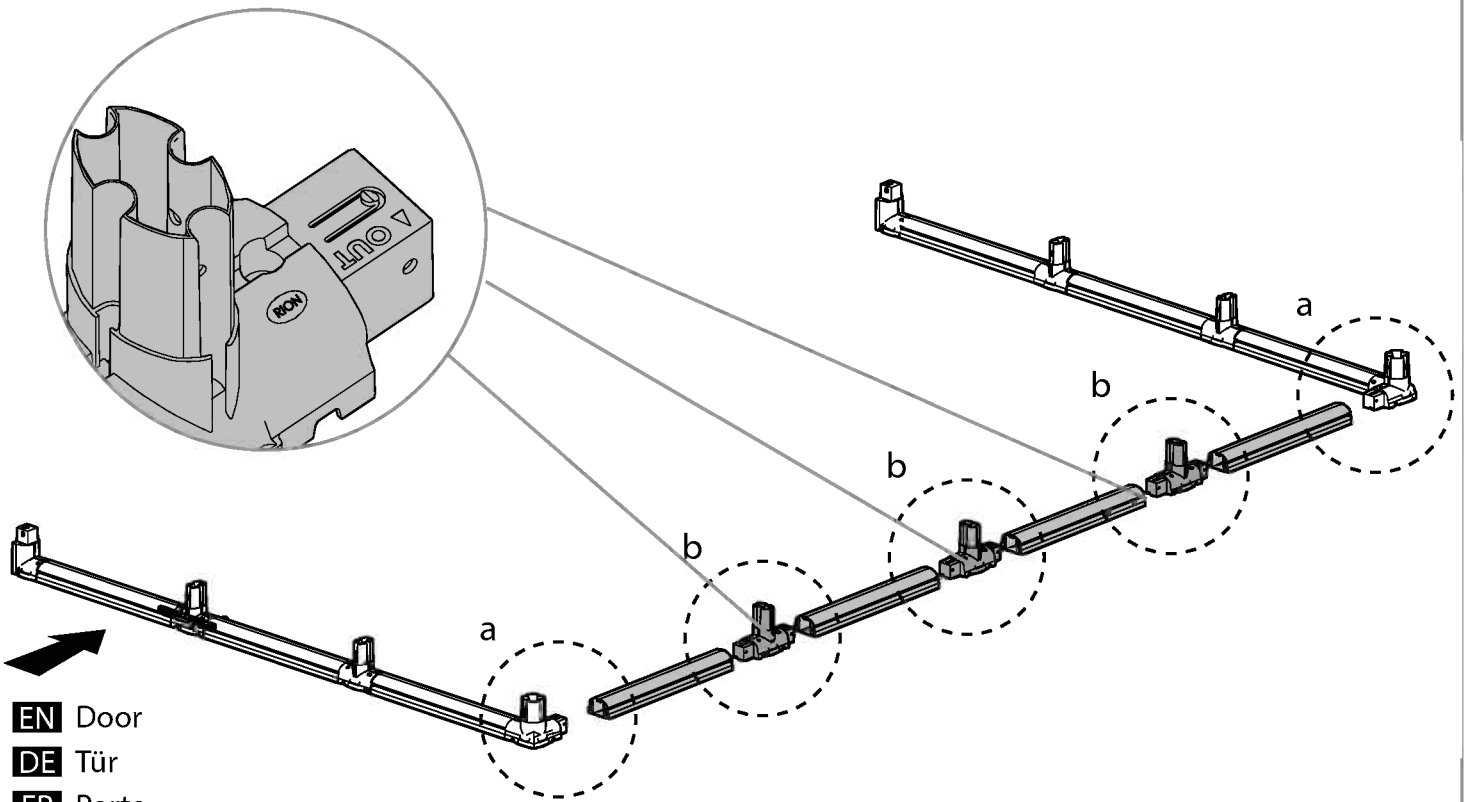
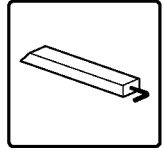

- EN** Door
- DE** Tür
- FR** Porte
- ES** Puerta

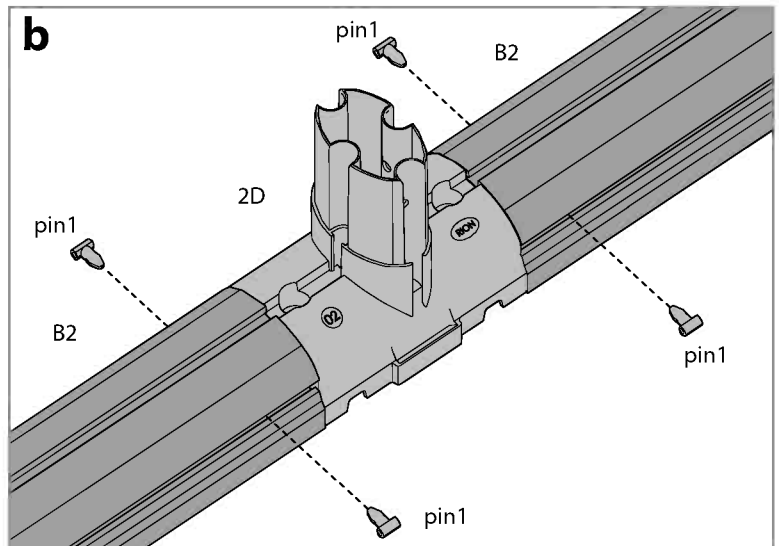
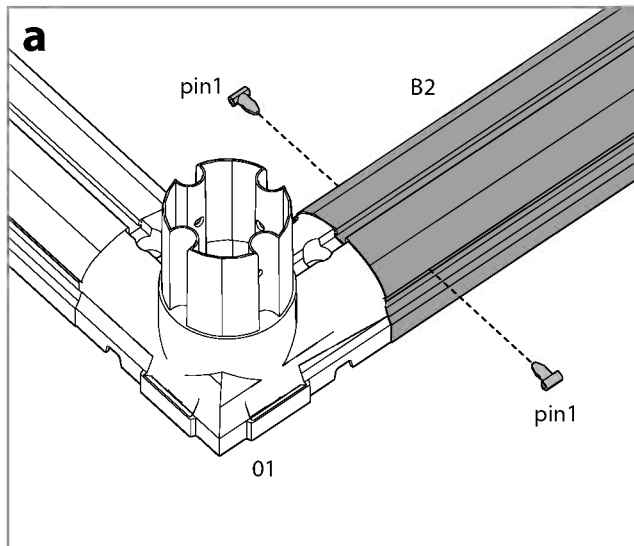

5

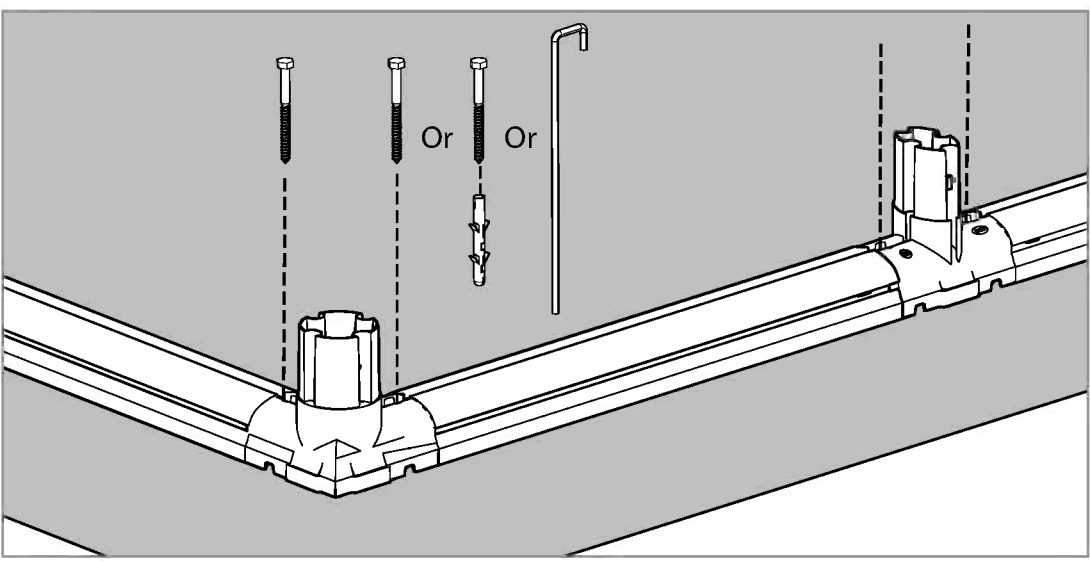
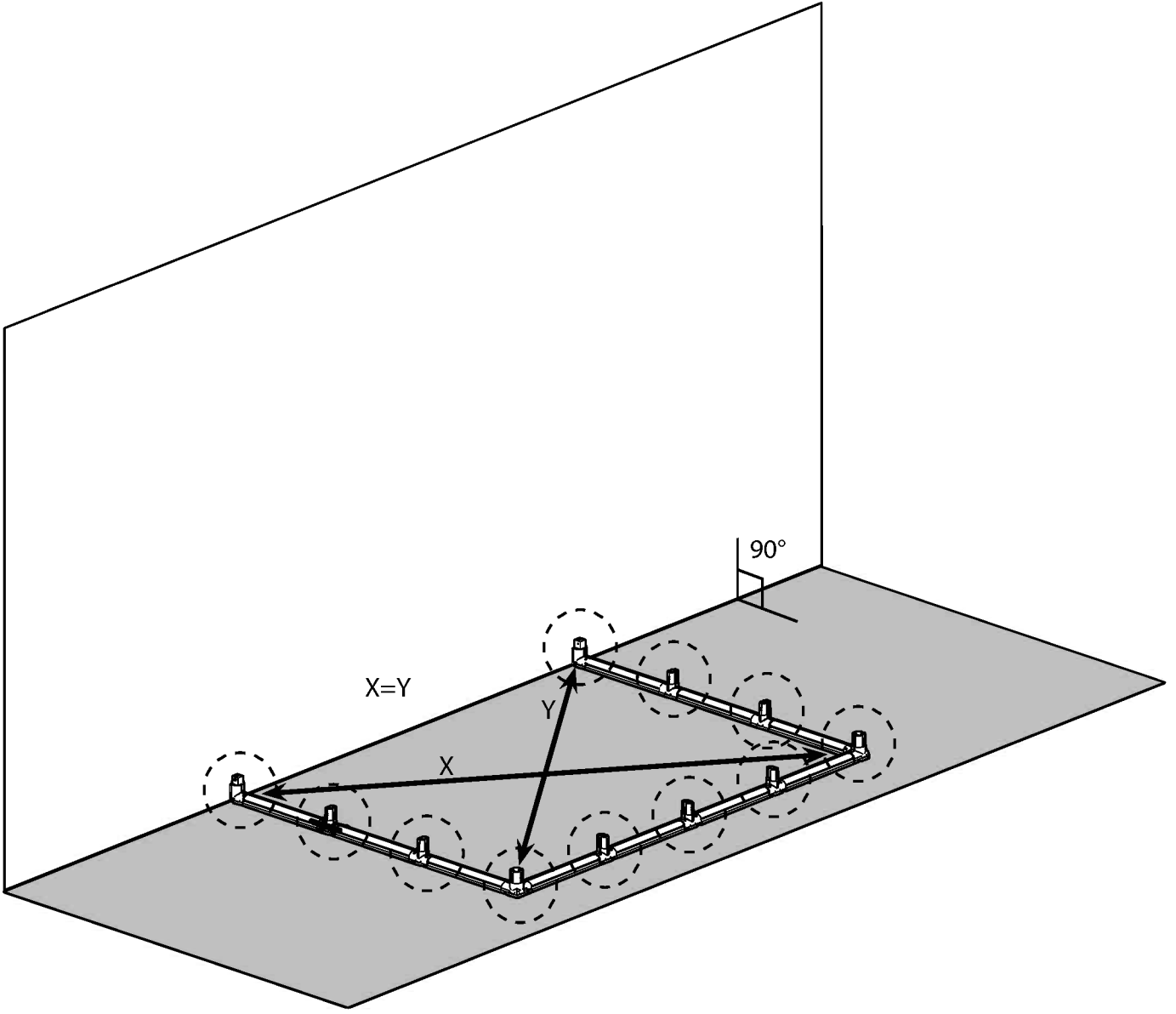
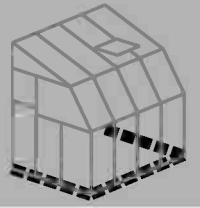

6

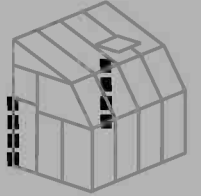

Item		Qty.
B1		2
pin1		4

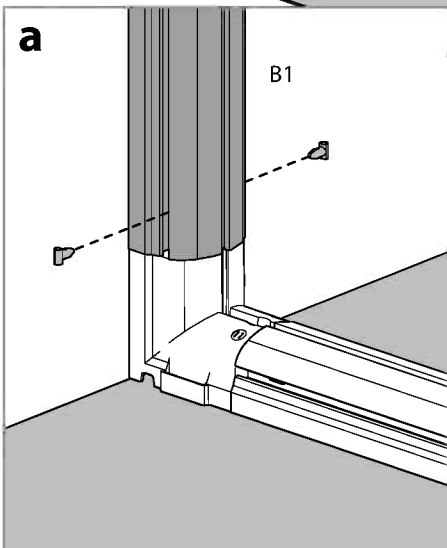
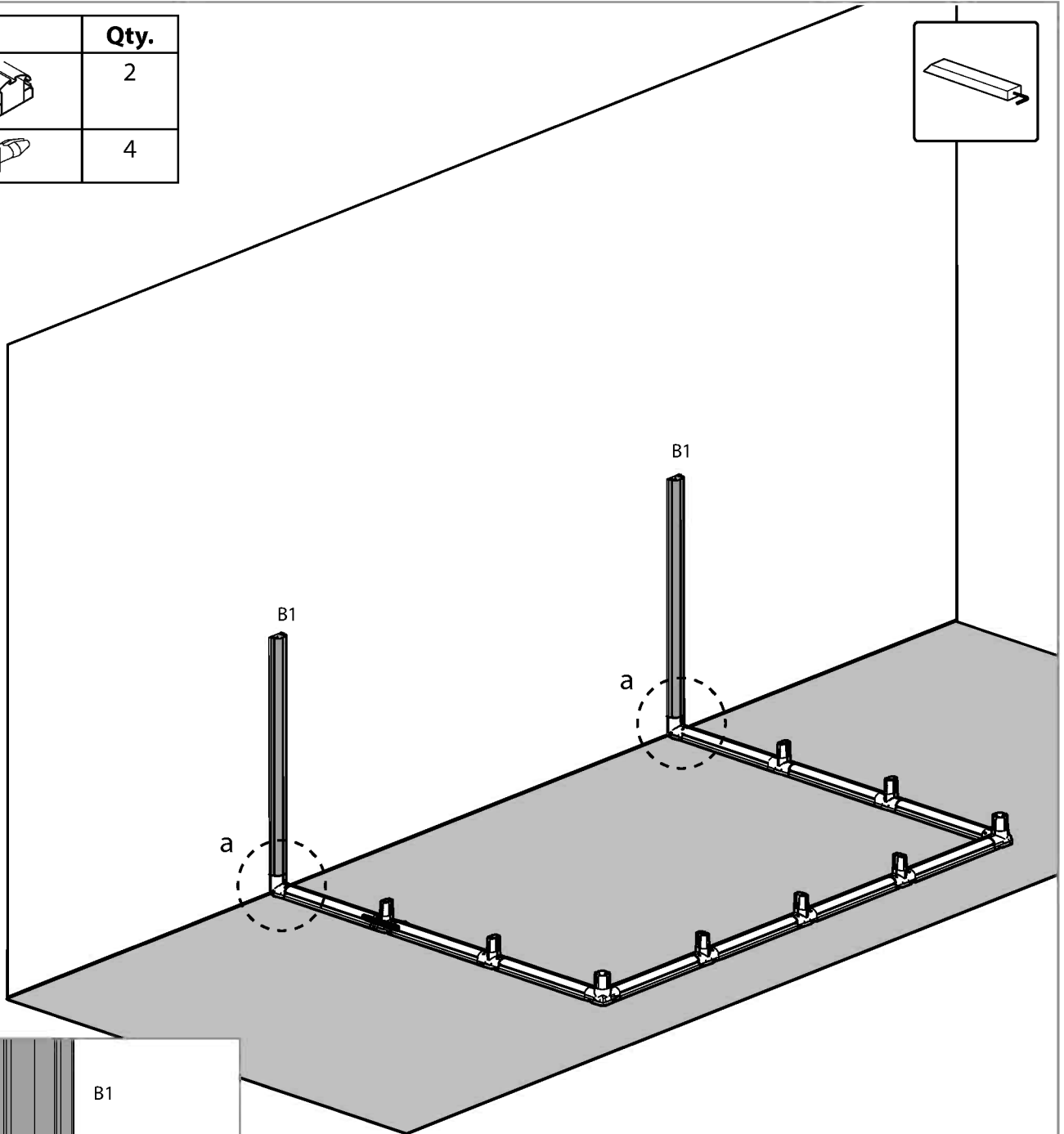
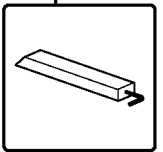

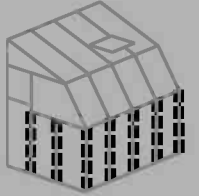

Item		Qty.
E1		7
R1		2
pin1		18

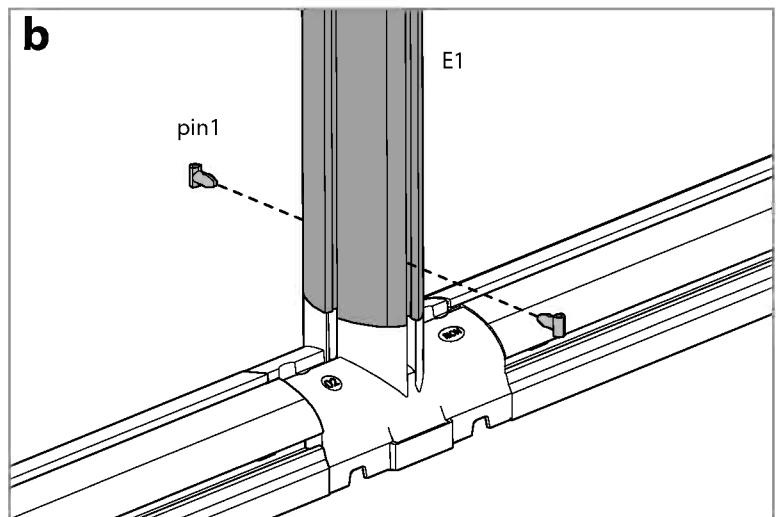
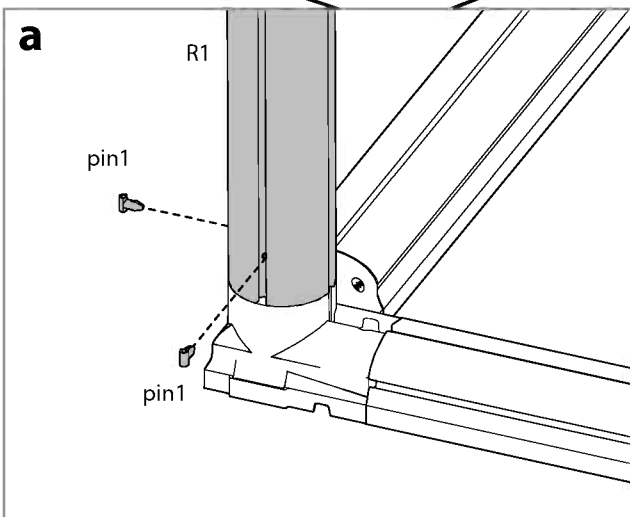
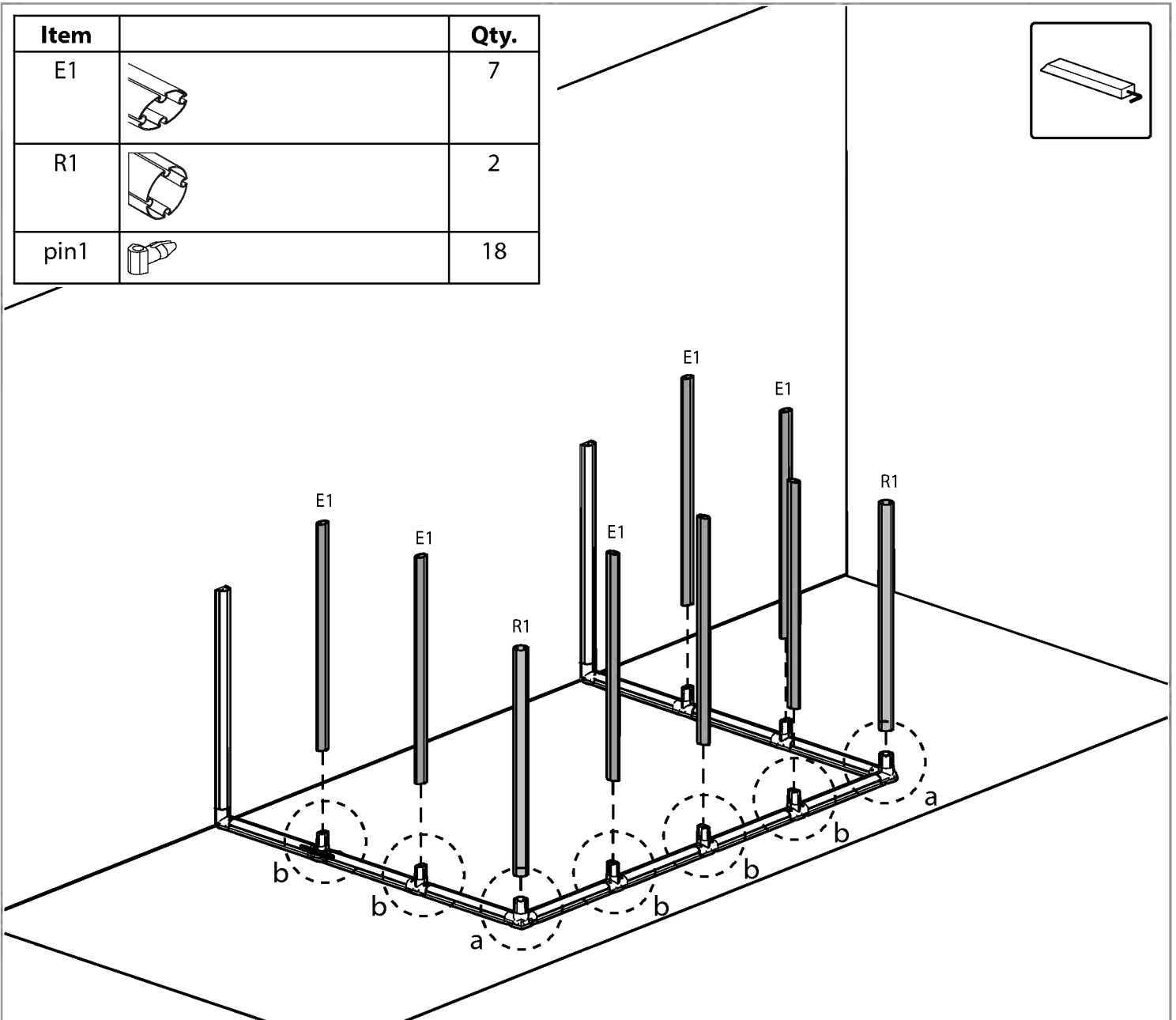
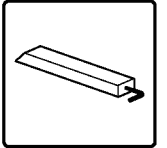

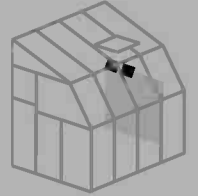

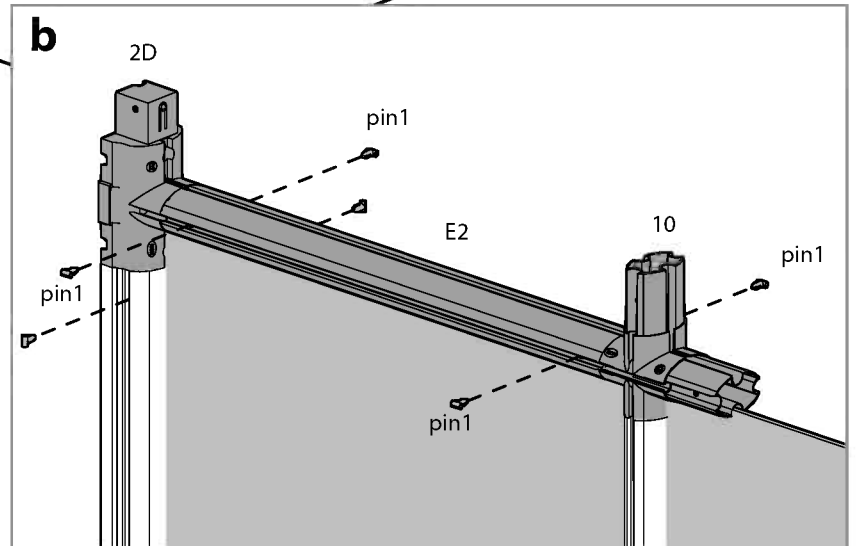
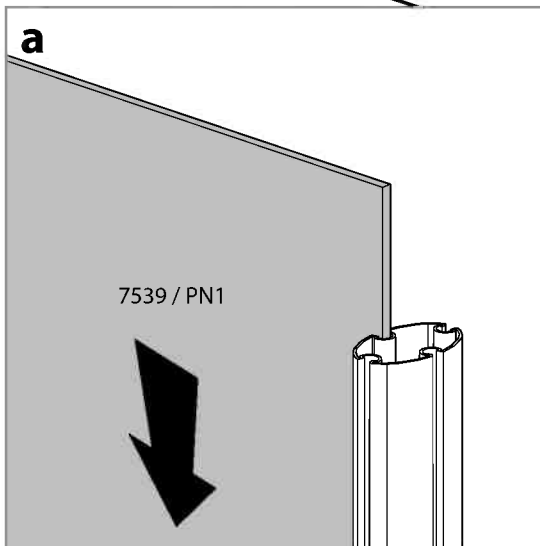
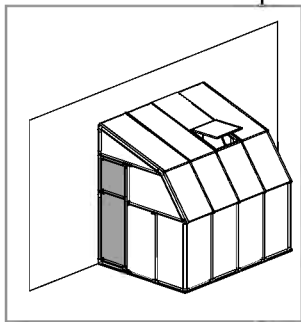
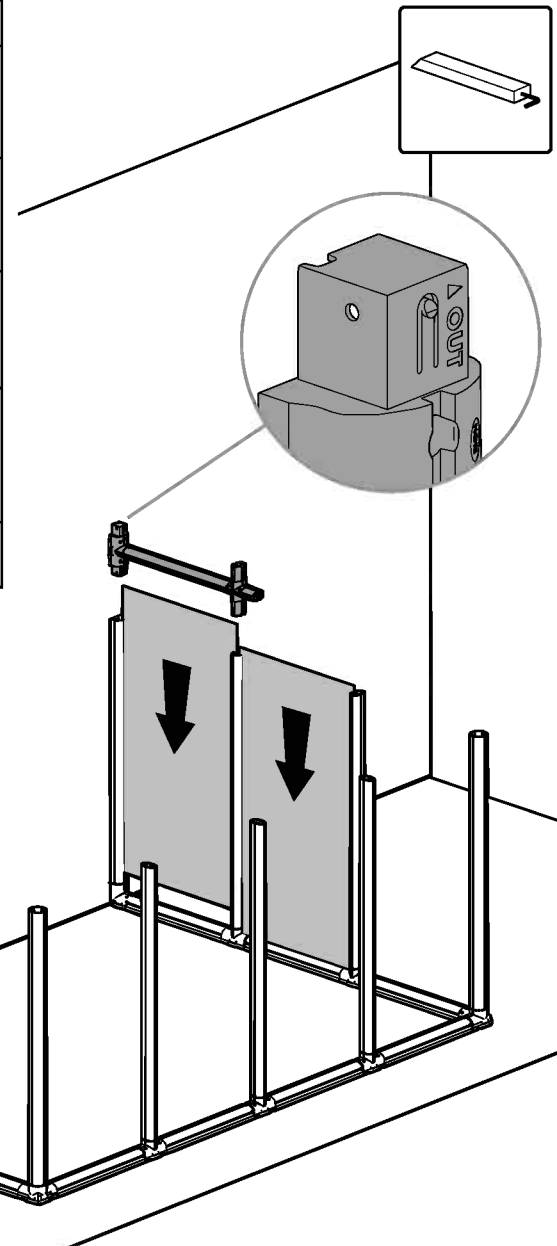

Item		Qty.
10		1
2D		1
E2		1
7539 / PN1		2
pin1		8

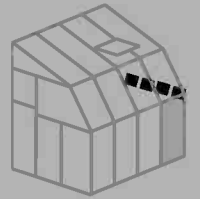



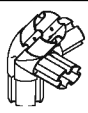
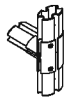
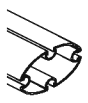



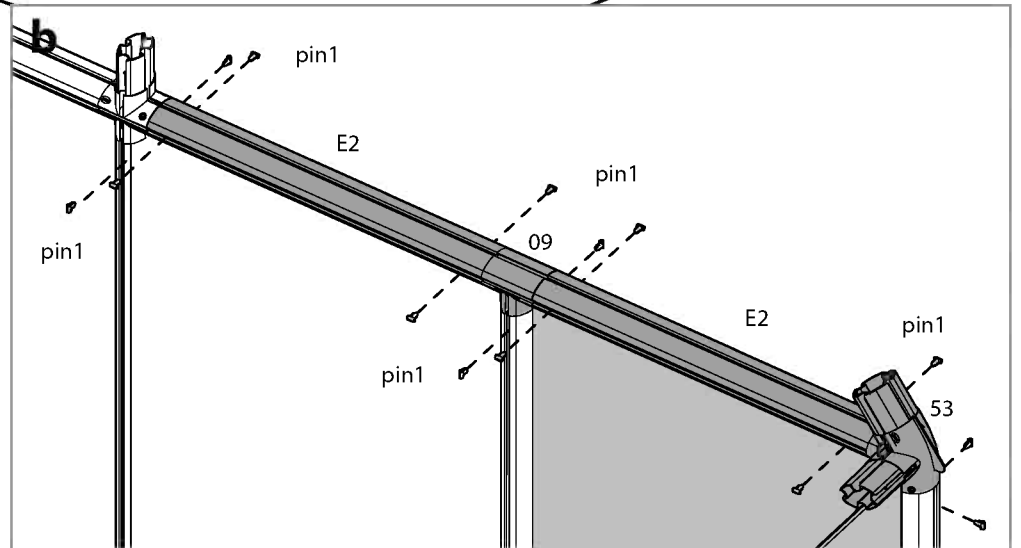
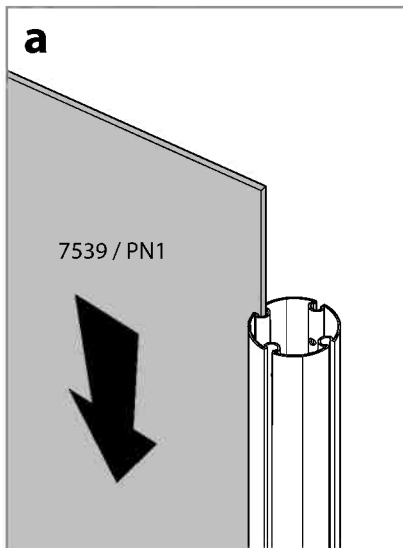
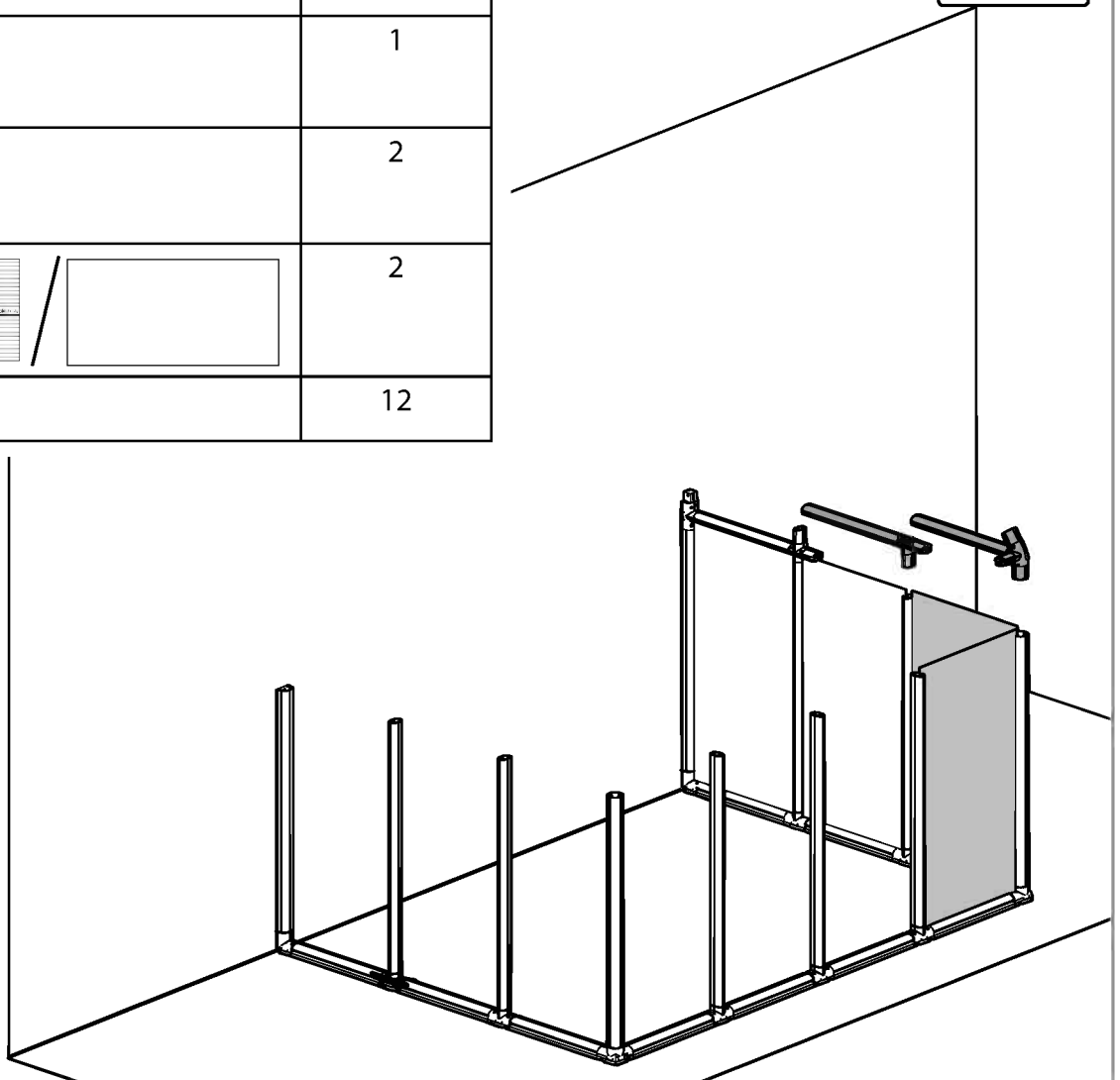
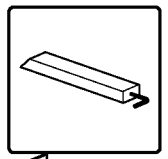

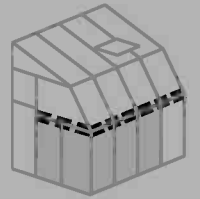
9 

Item		Qty.
53		1
09		1
E2		2
7539/ PN1		2
pin1		12



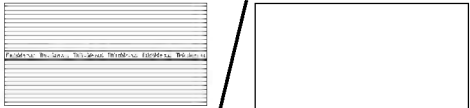

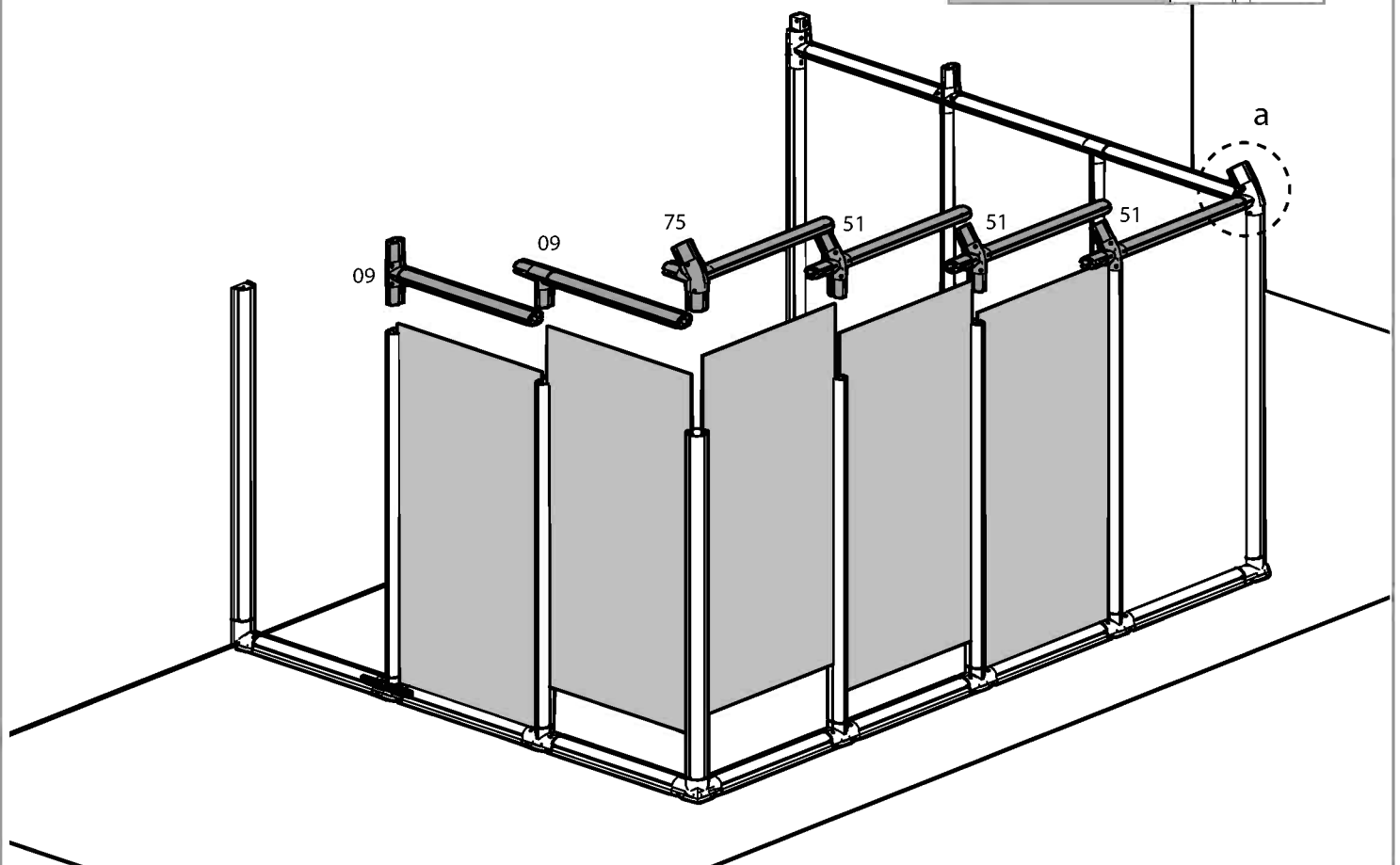
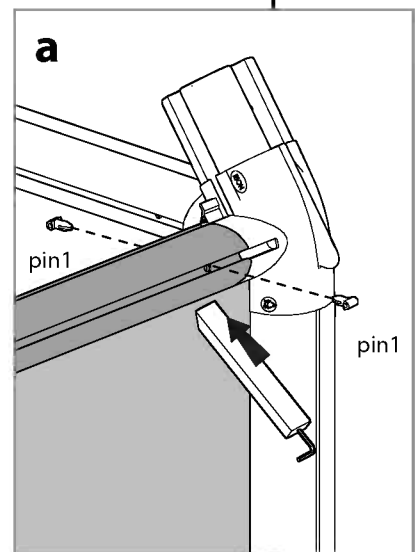
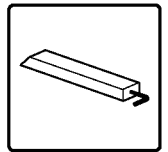

Item		Qty.
51		3
09		2
75		1
E2		6
7539 / PN1		5
pin 1		36

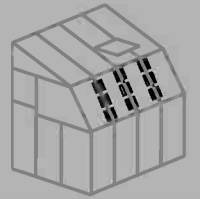



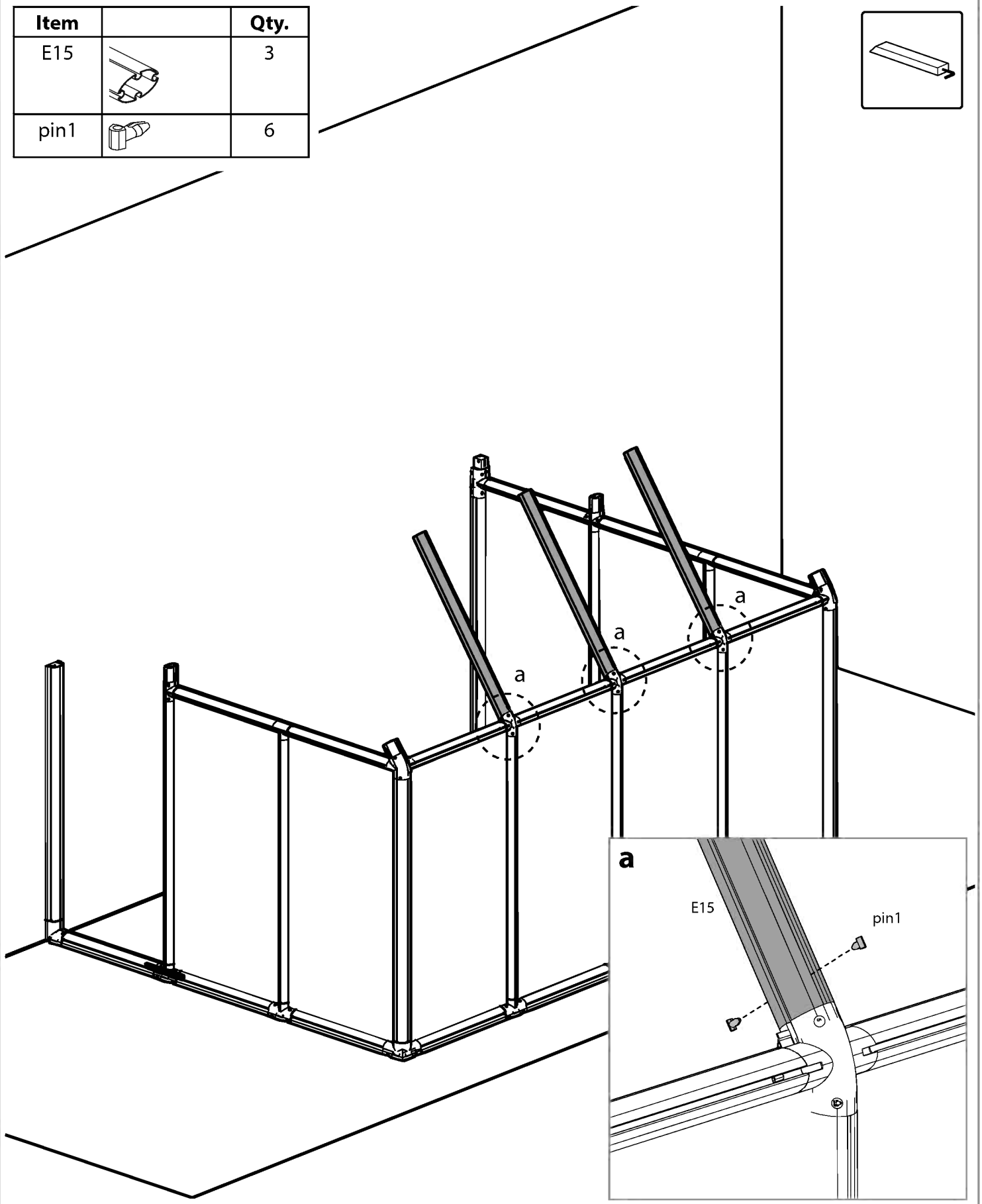
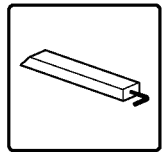

Item		Qty.
E15		3
pin1		6

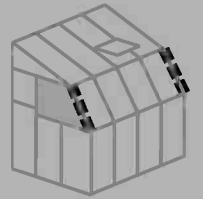

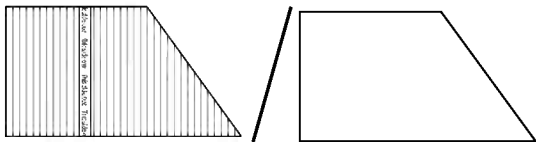
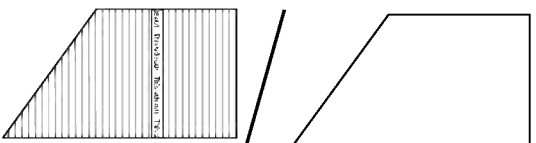

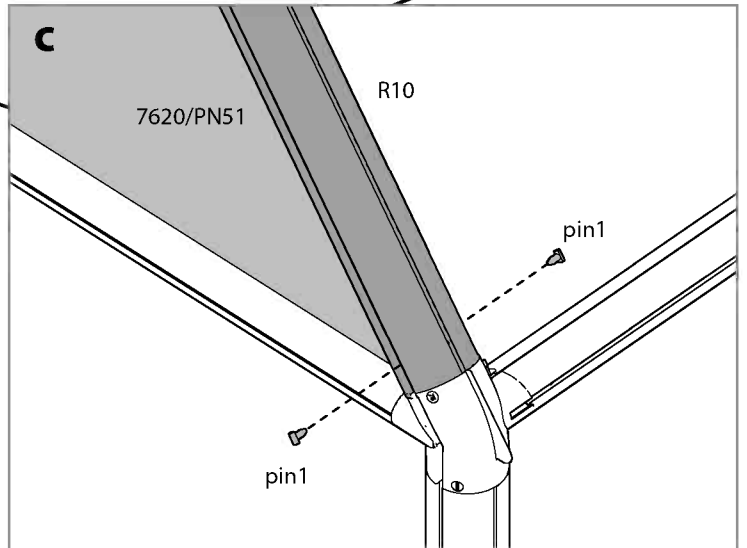
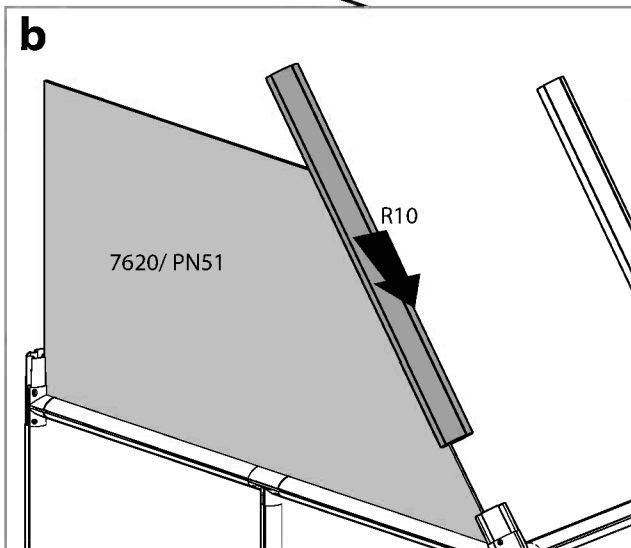
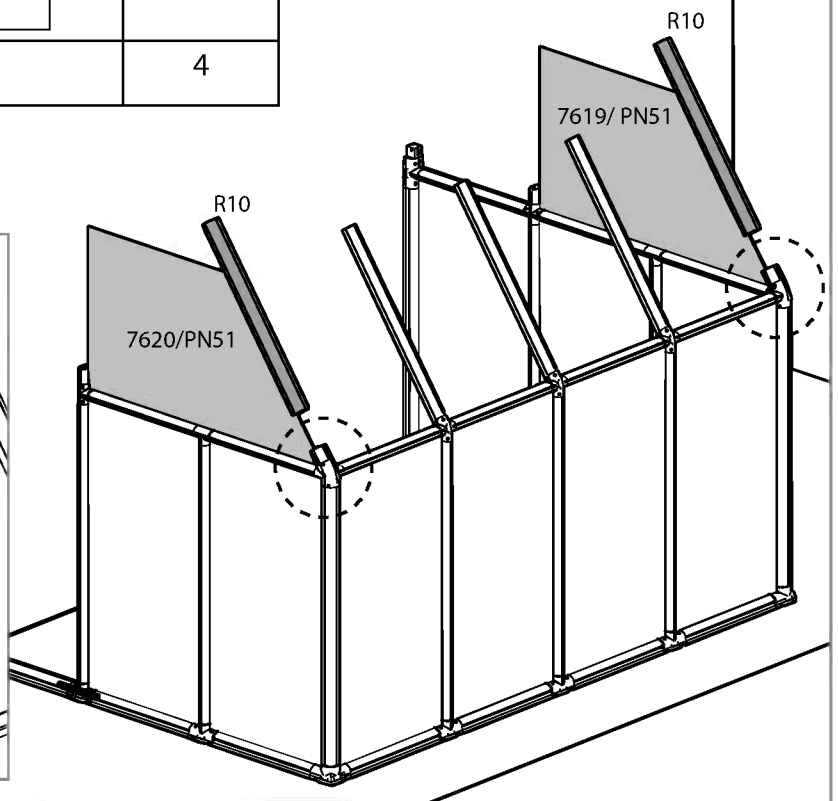
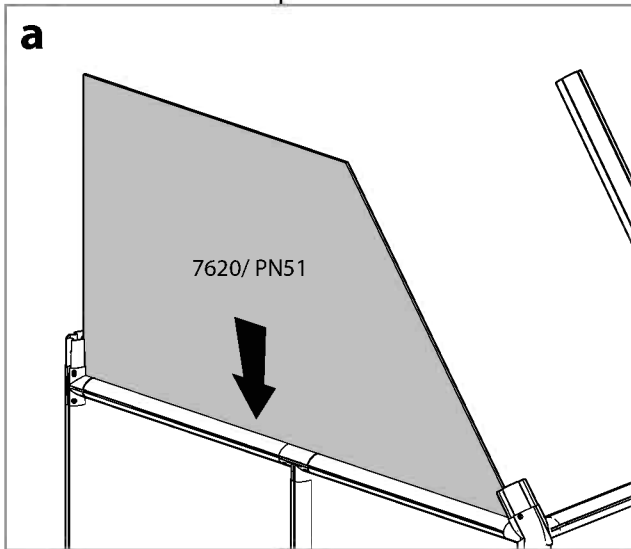
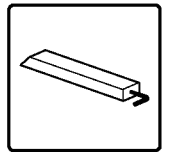

Item		Qty.
R10		2
7620/ PN51		1
7619/ PN51		1
pin1		4

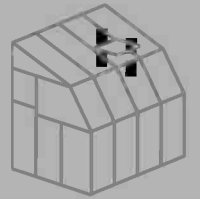

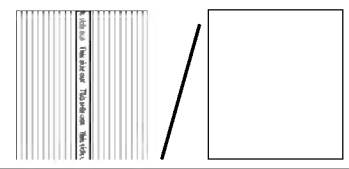

Item		Qty.
E13		1
B12		1
pin1		4
7628/ PN53		1

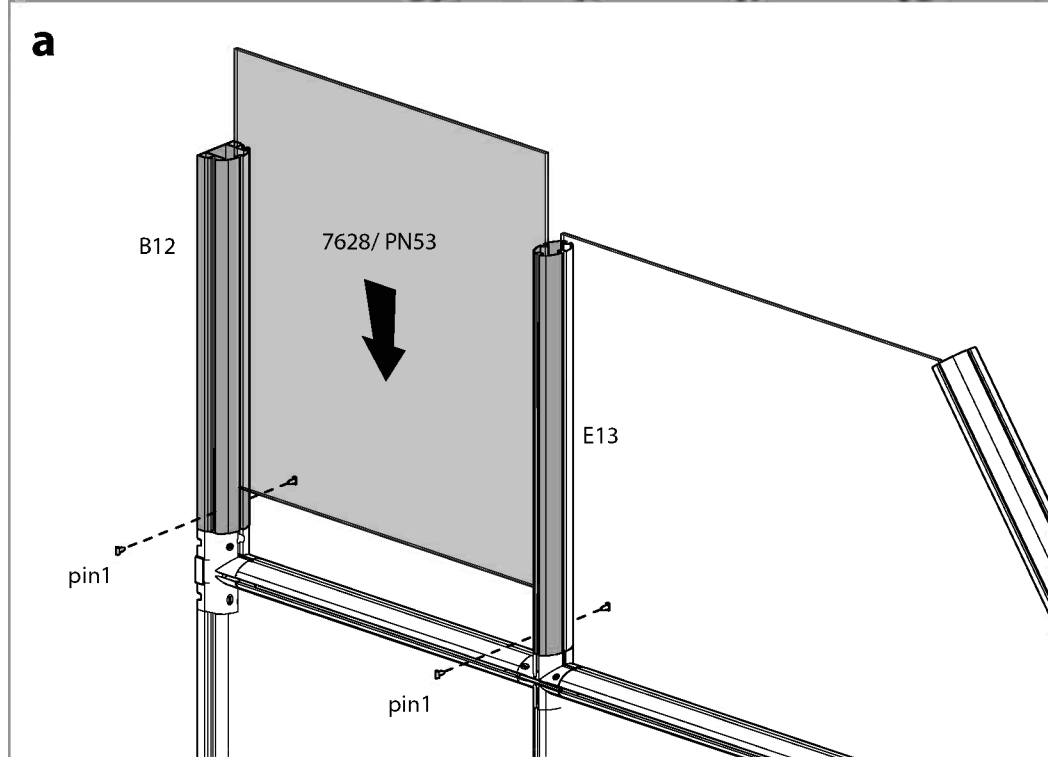
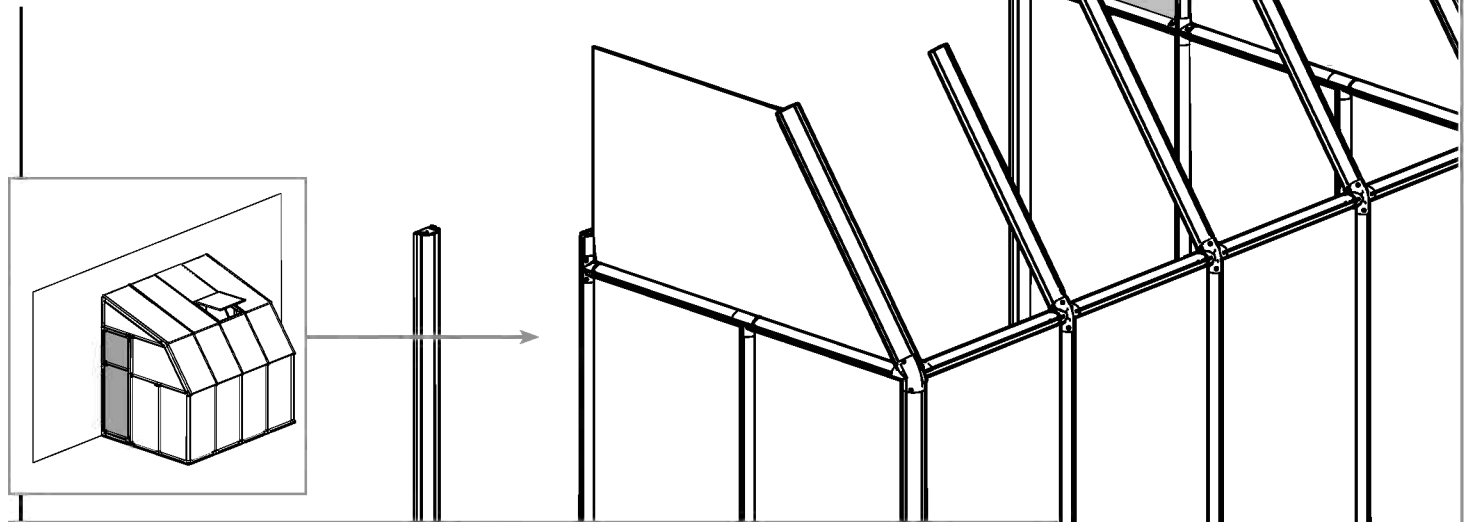
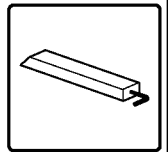

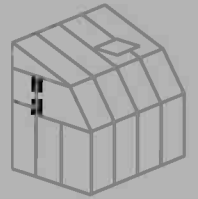

Item		Qty.
E13		1
B12		1
15		1
pin1		6

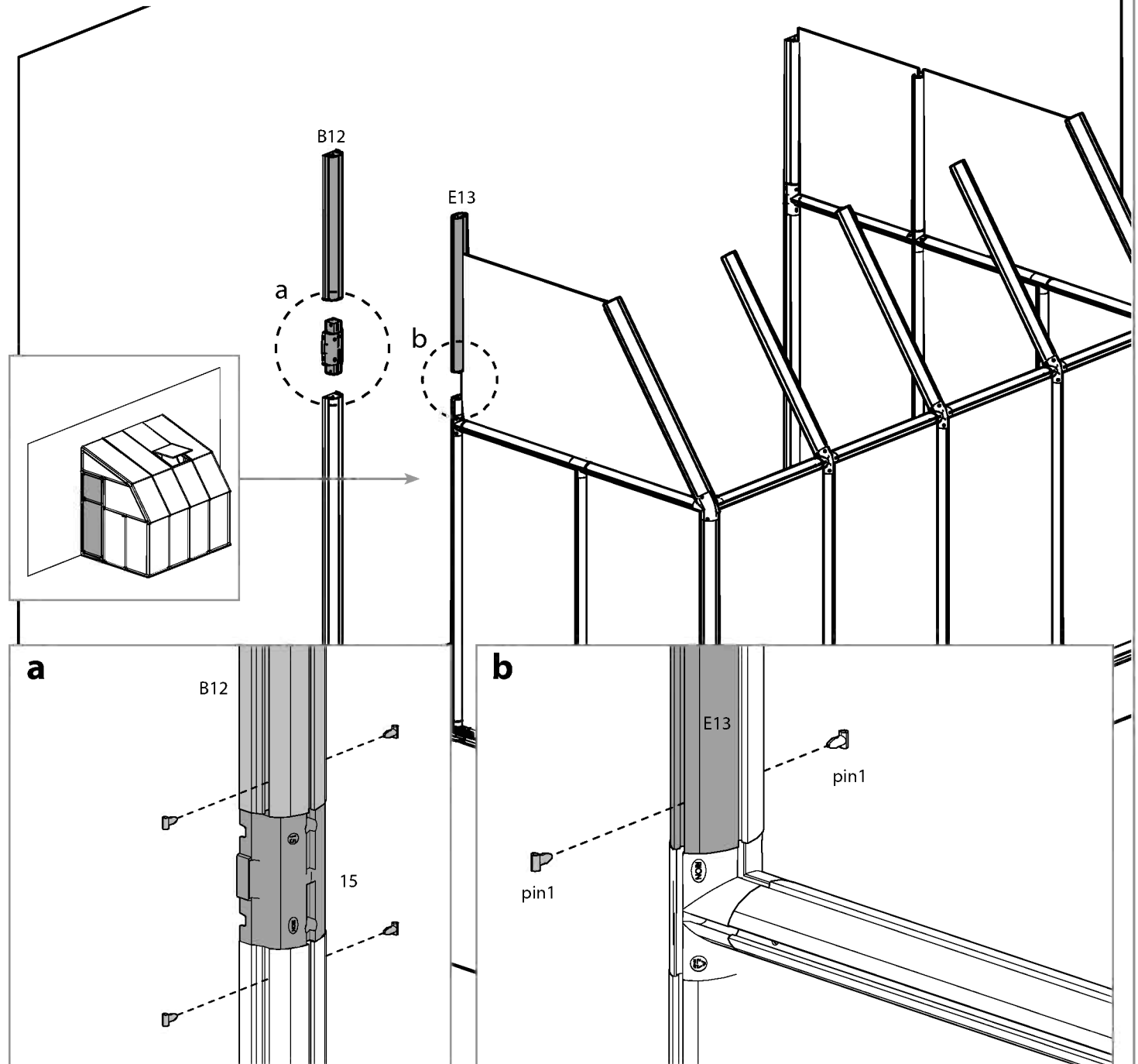
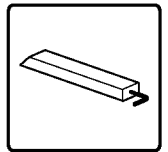

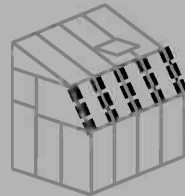

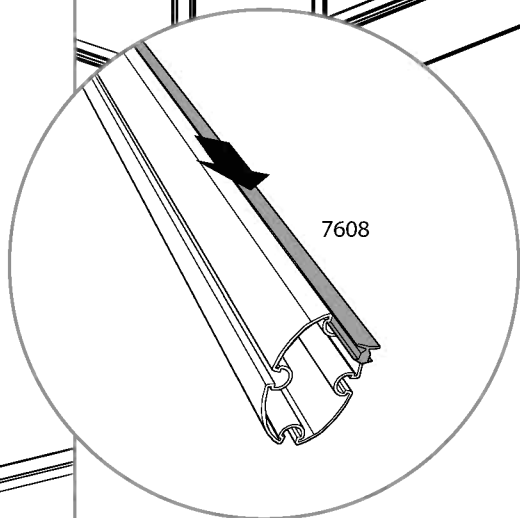
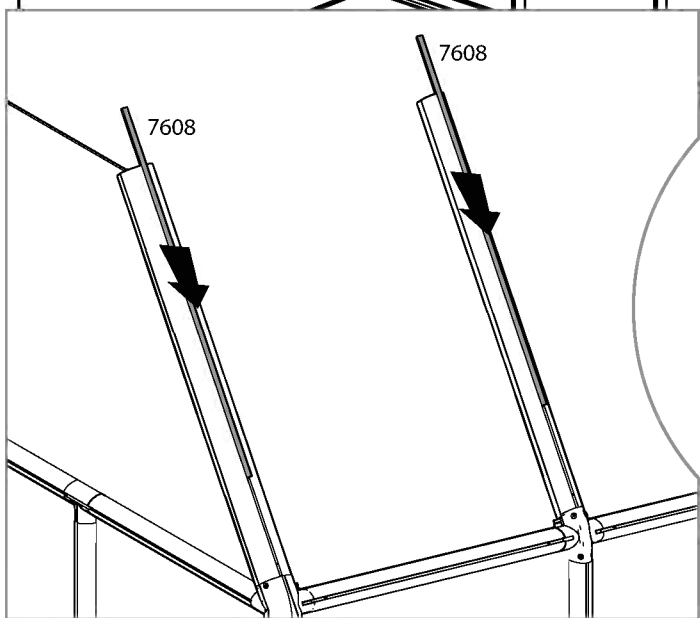
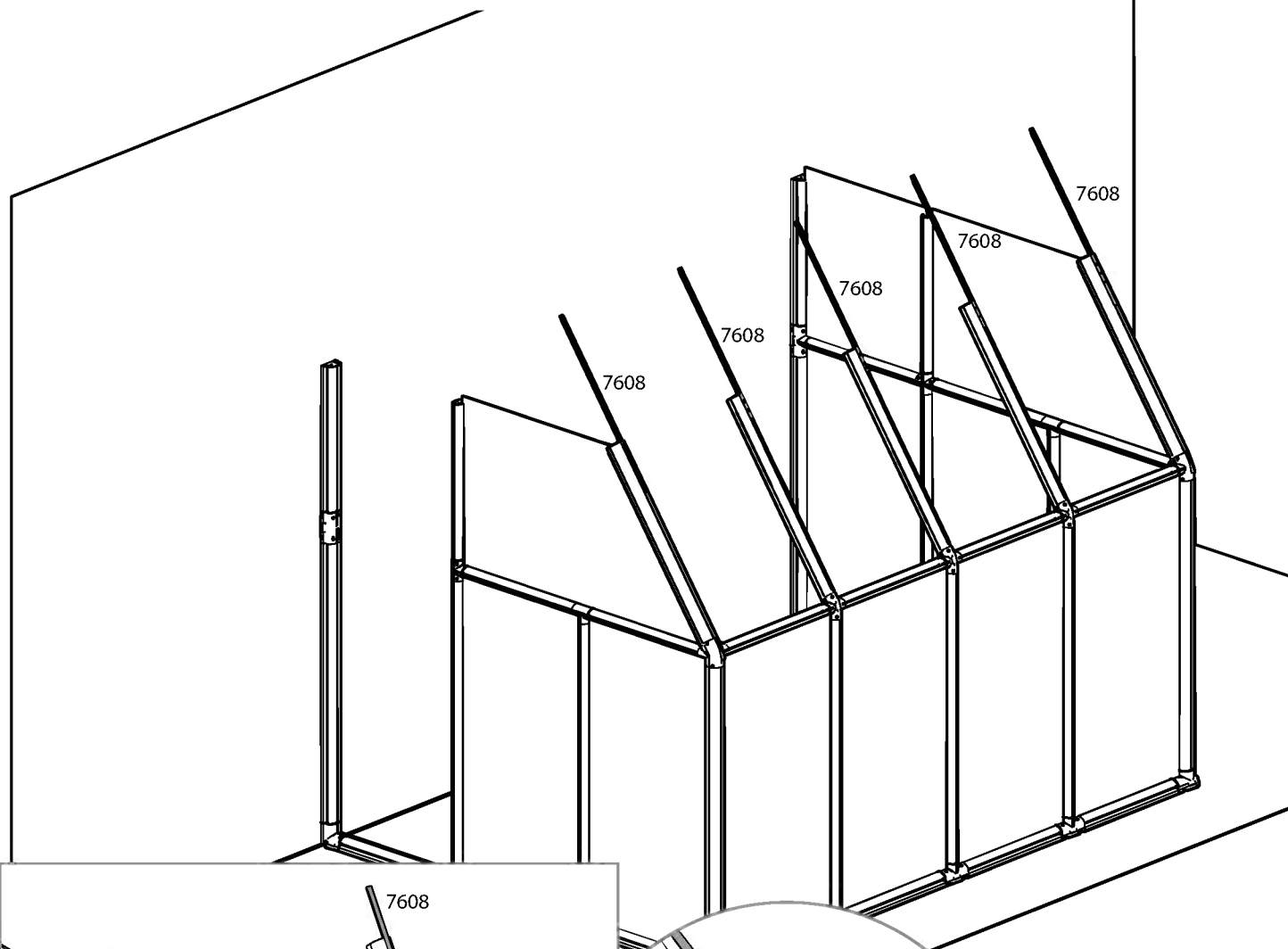

Item		Qty.
7608		5

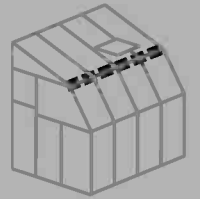

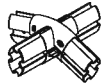

Item		Qty.
E2		4
51		3
pin1		18

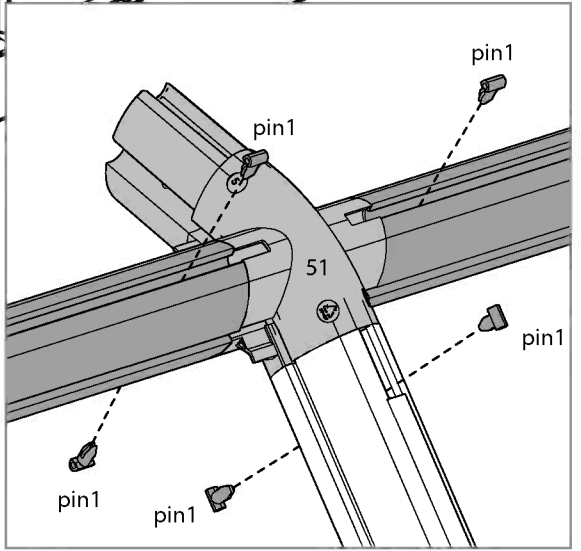
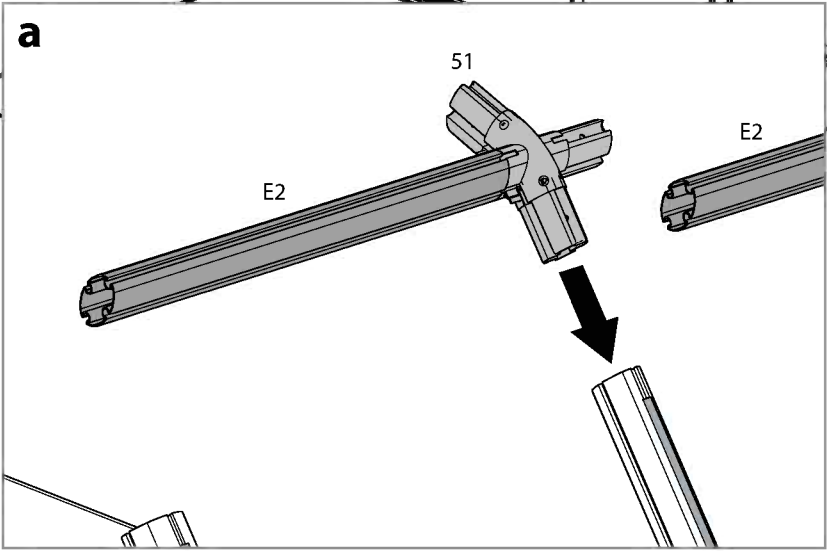
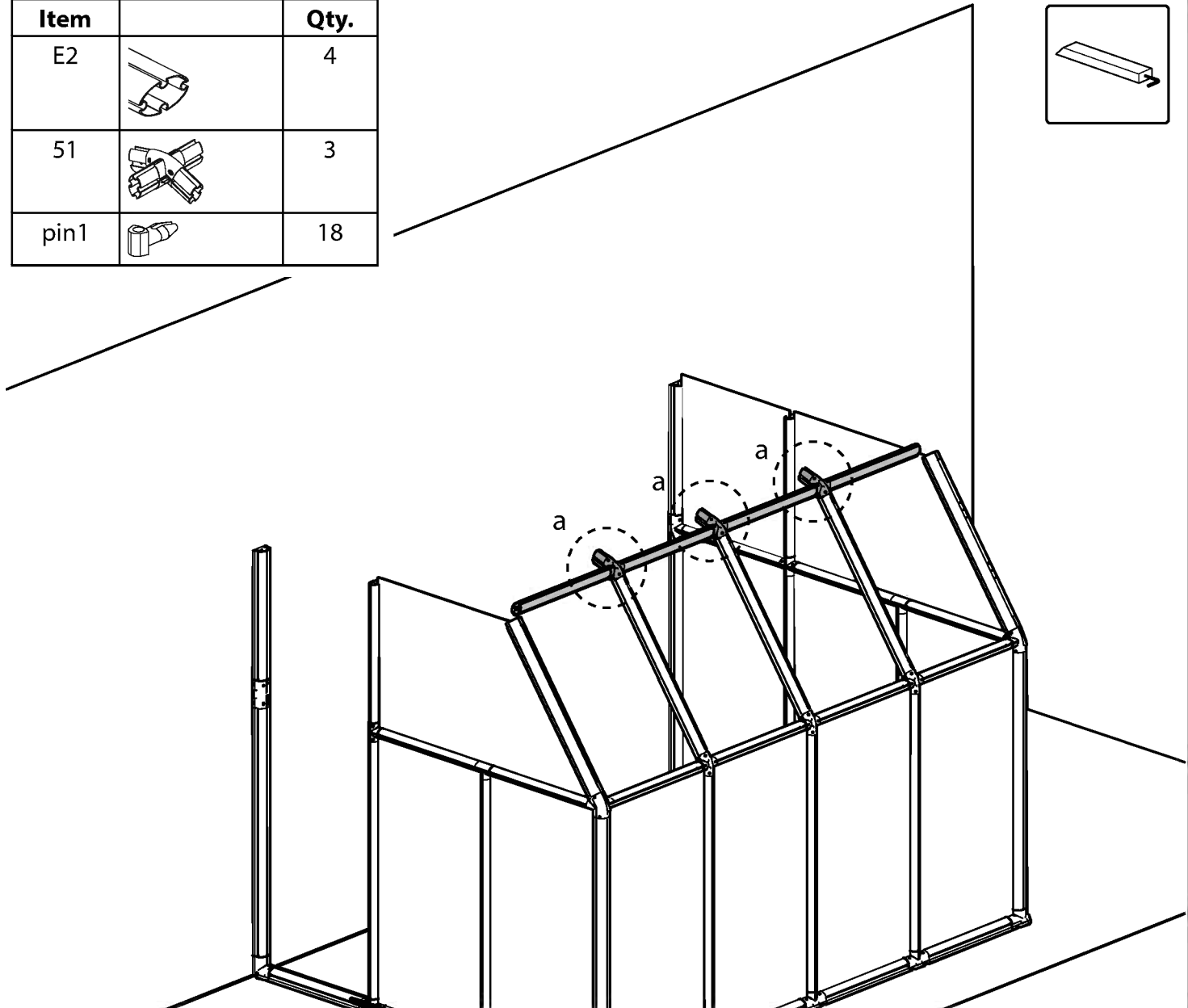
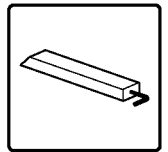

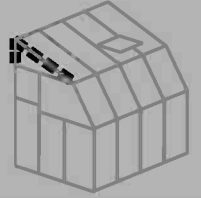





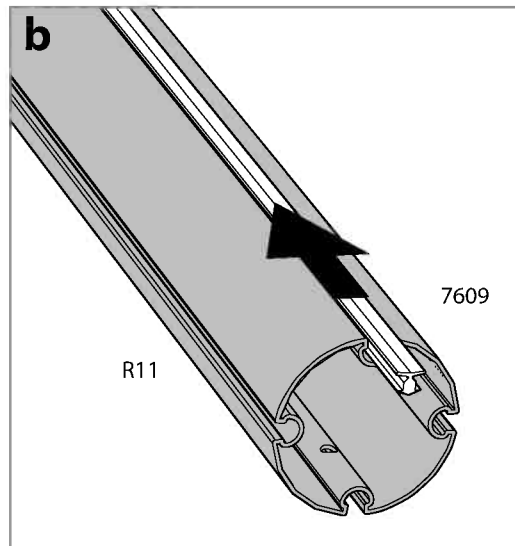
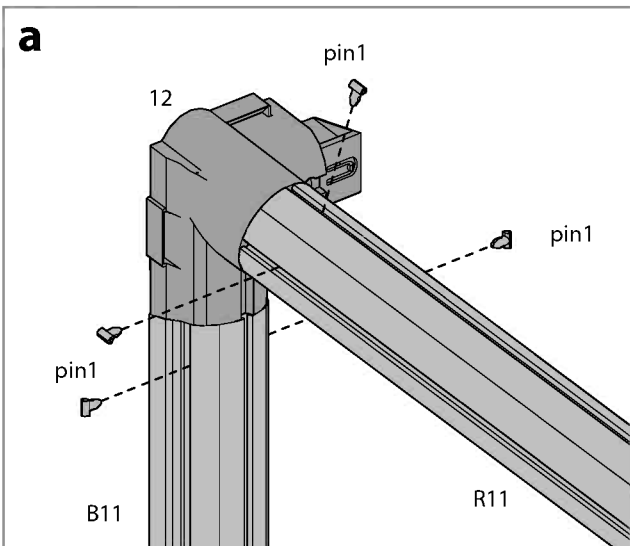
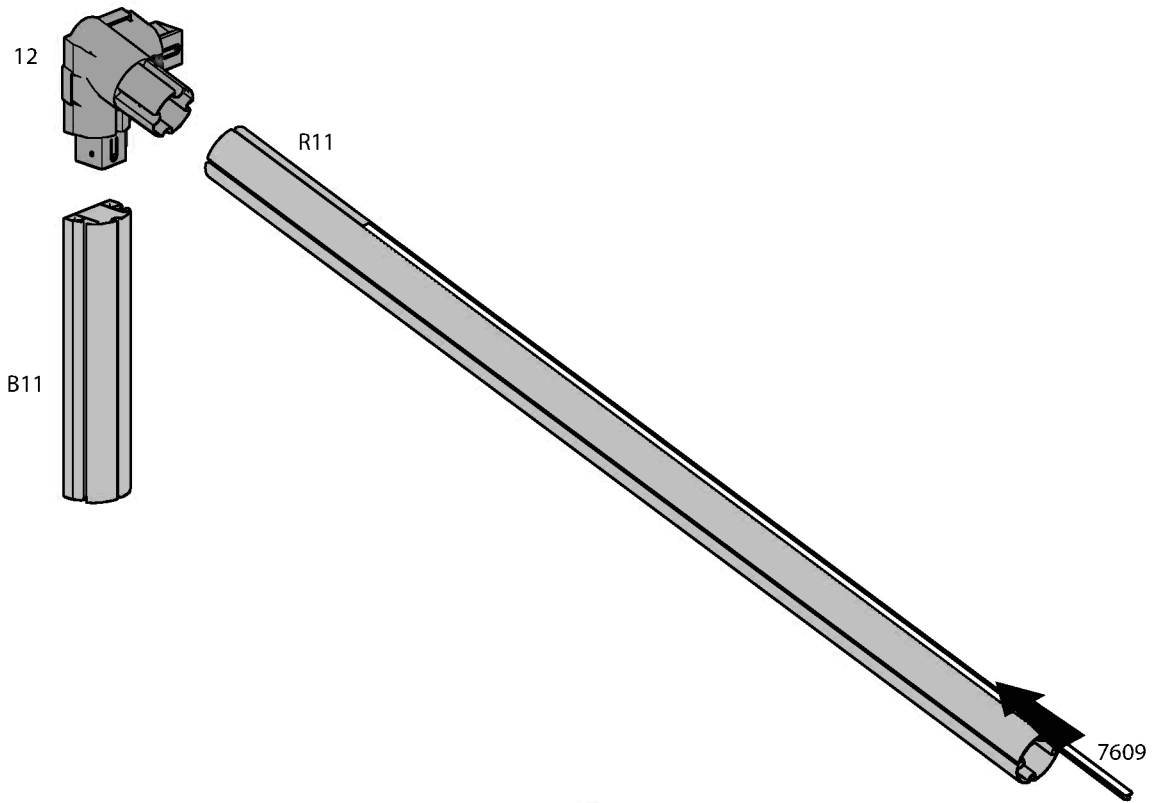
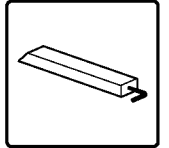

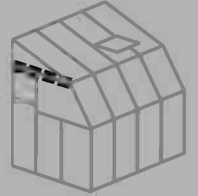

Item		Qty.
R11		1
B11		1
7609		1

Item		Qty.
12		1
pin1		5







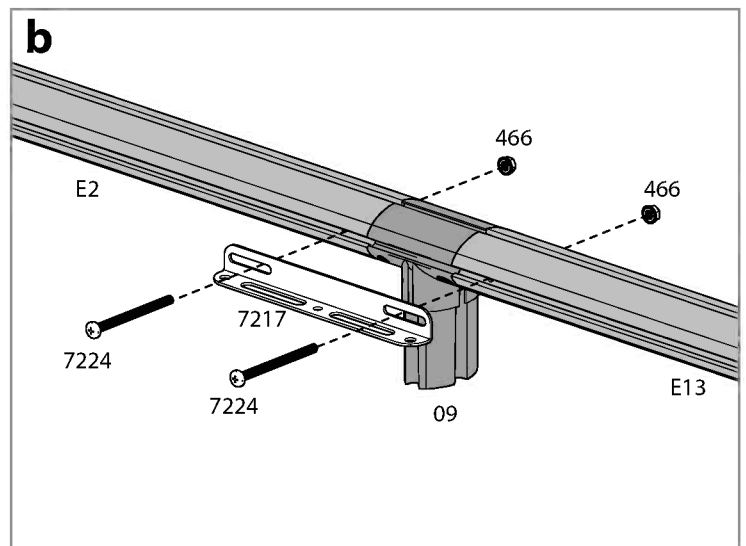
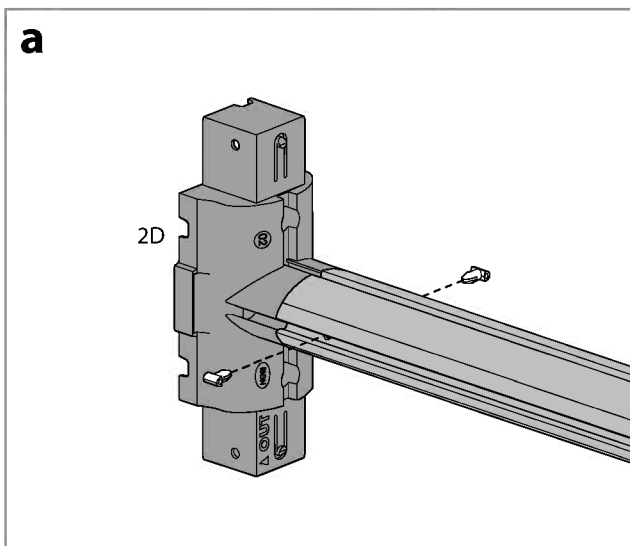
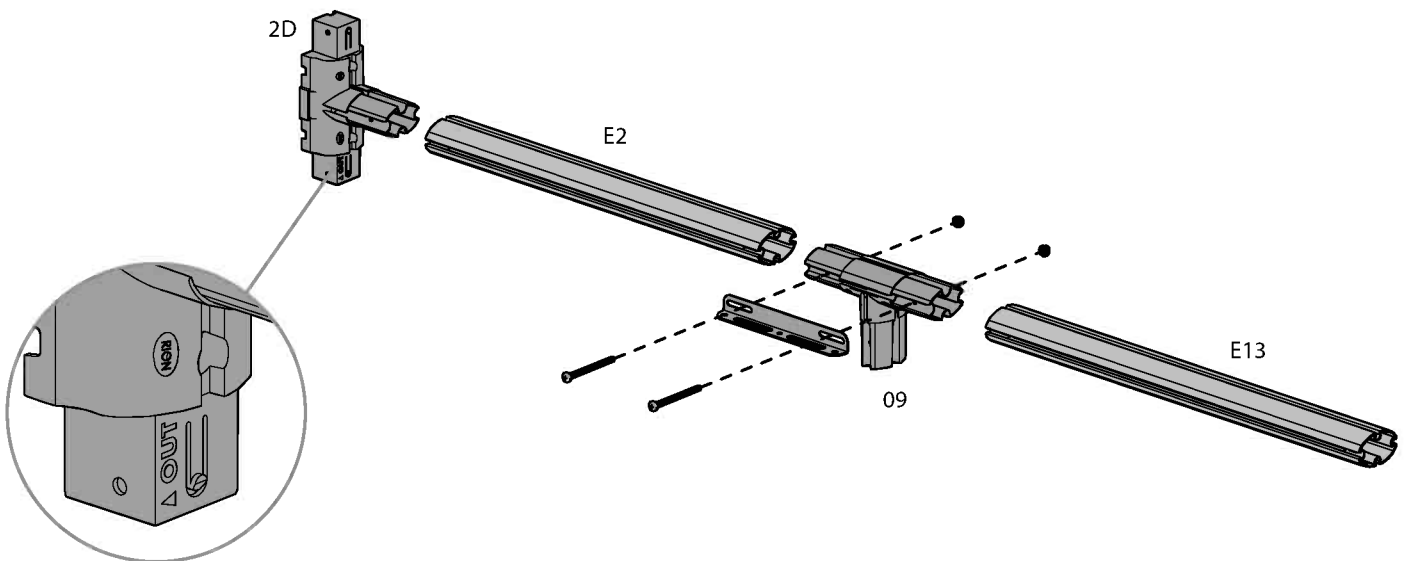

Item		Qty.
2D		1
09		1
E2		1
E13		1

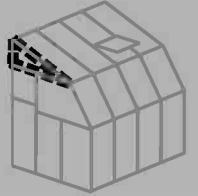
Item		Qty.
7224		2
7217		1
466		2
pin1		2



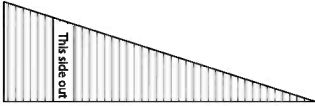

Item		Qty.
71		1
7618		1
pin1		6

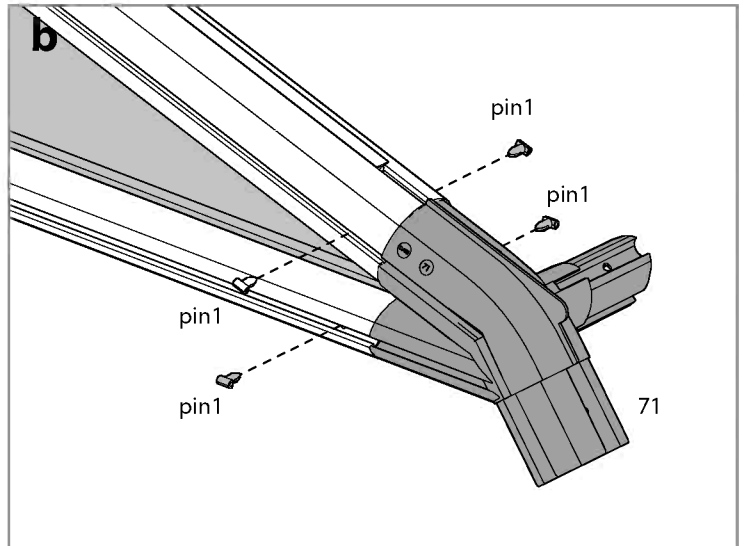
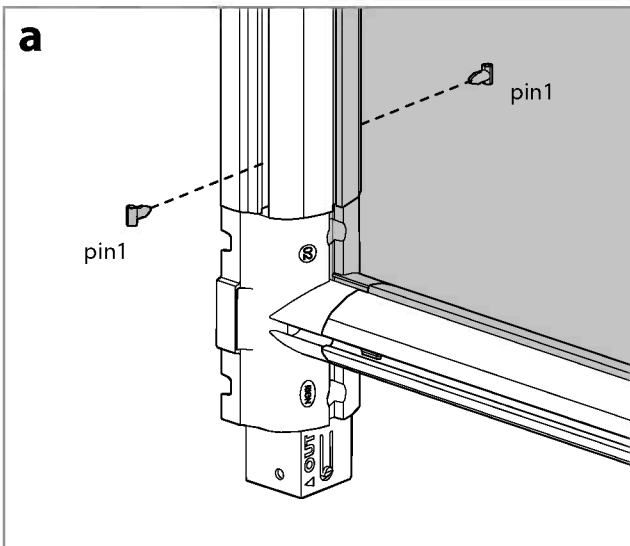
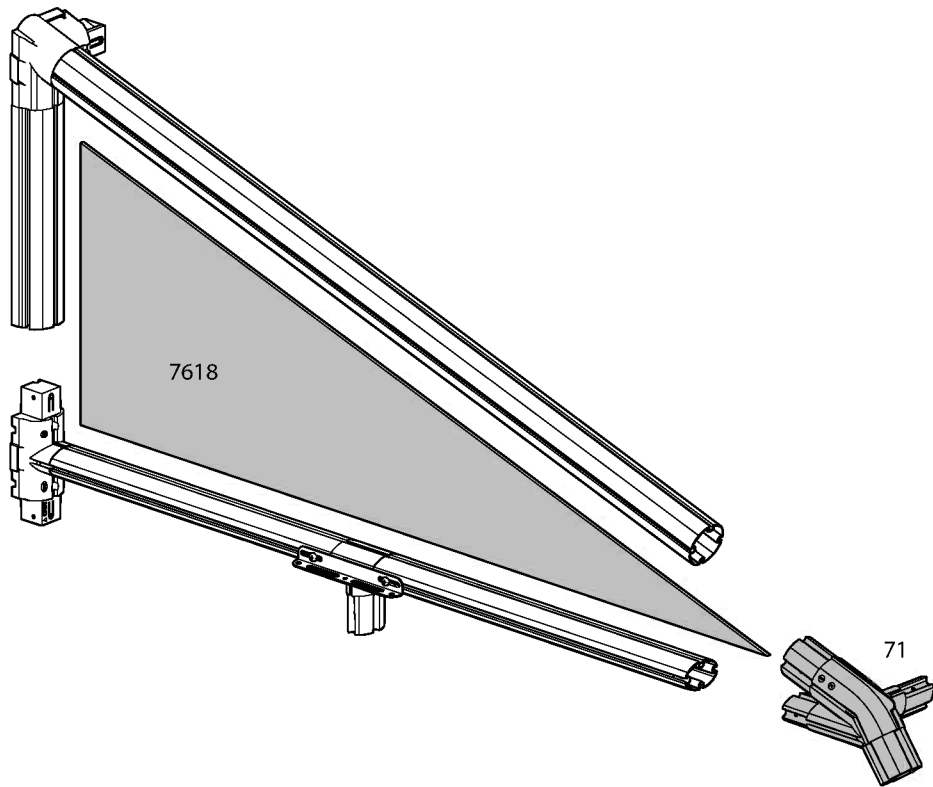
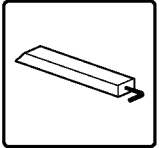

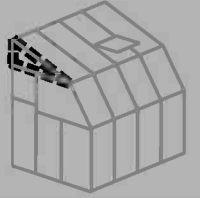

Item		Qty.
pin1		9

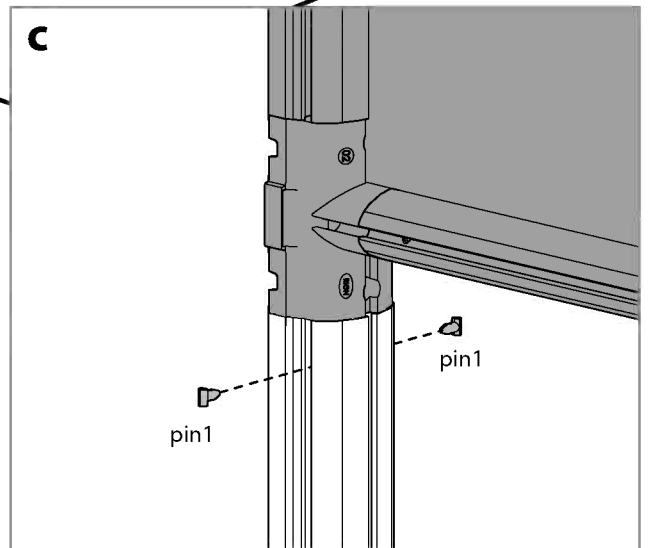
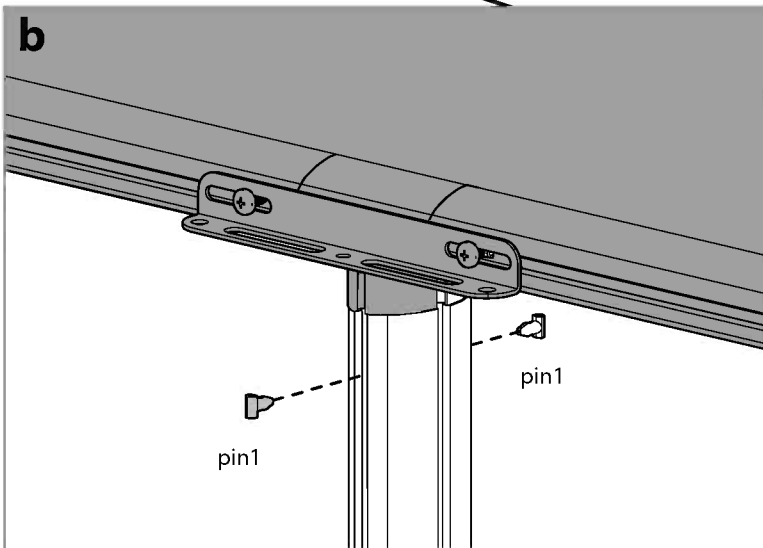
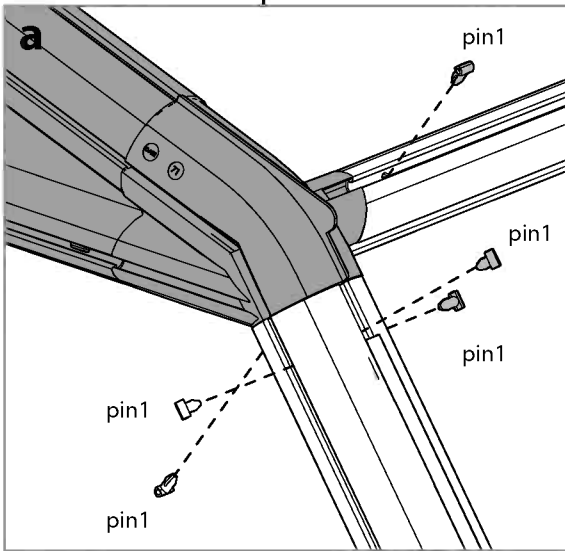
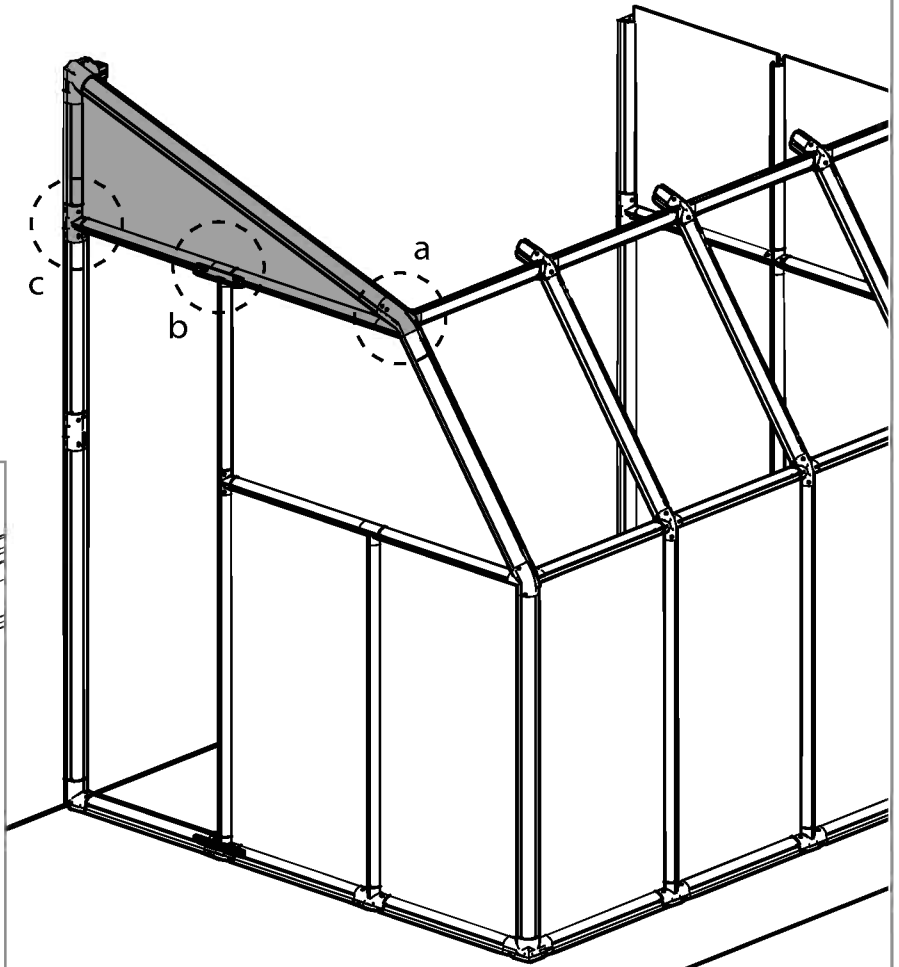
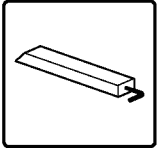

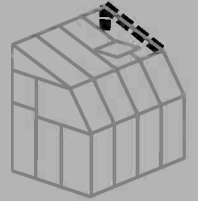



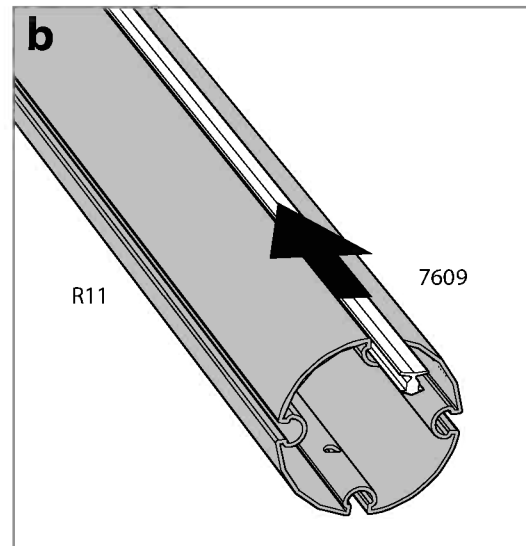
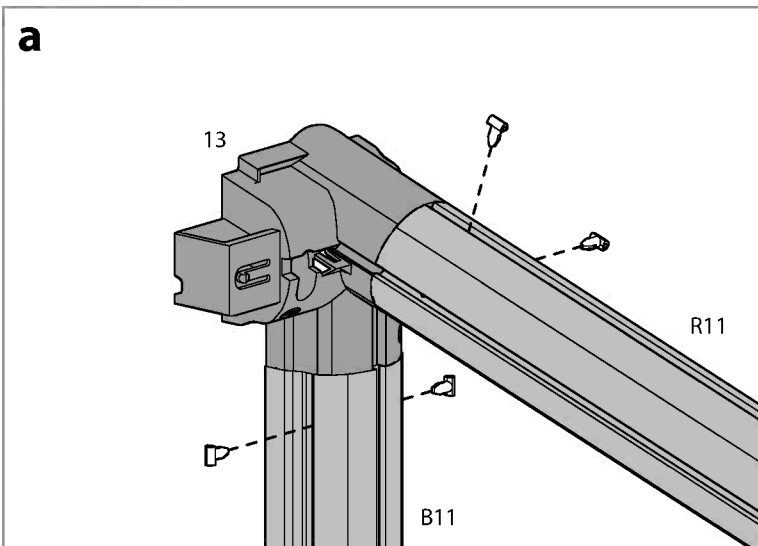
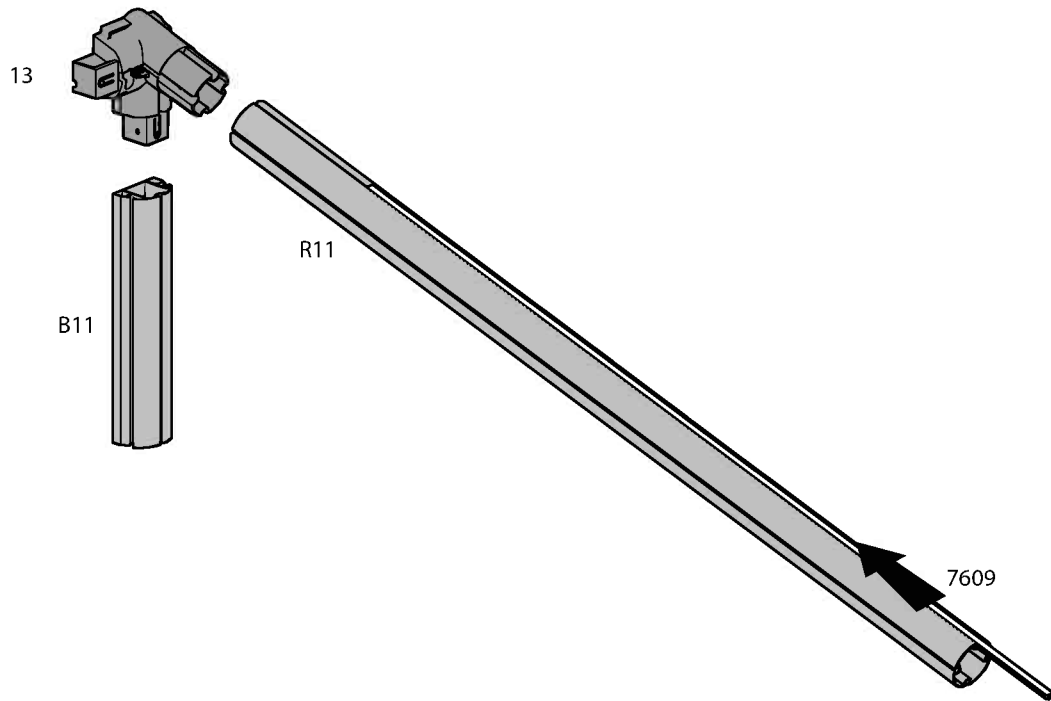
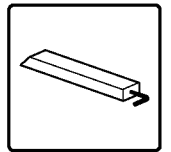

Item		Qty.
R11		1
B11		1
7609		1

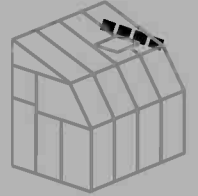
Item		Qty.
13		1
pin1		5





Item		Qty.
2D		1
09		1
E2		1
E13		1
pin1		6

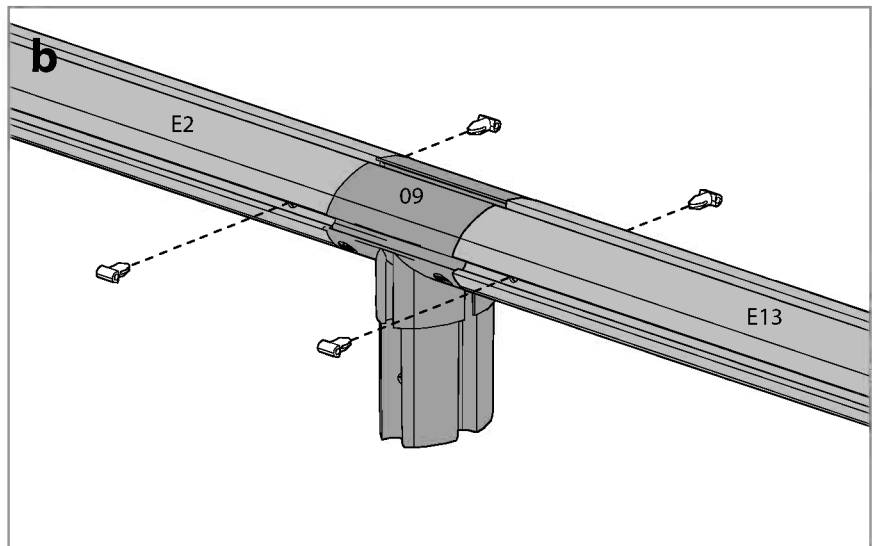
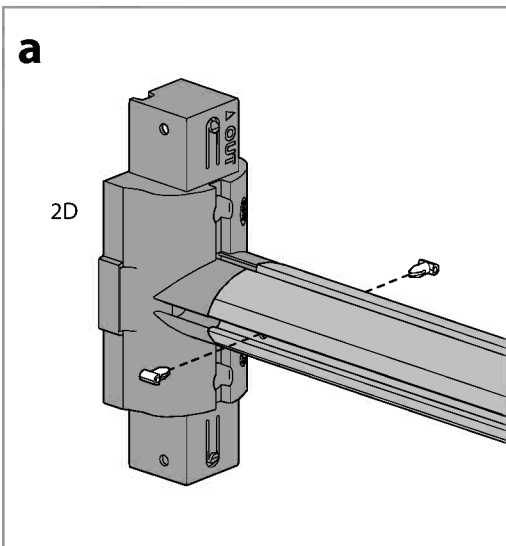
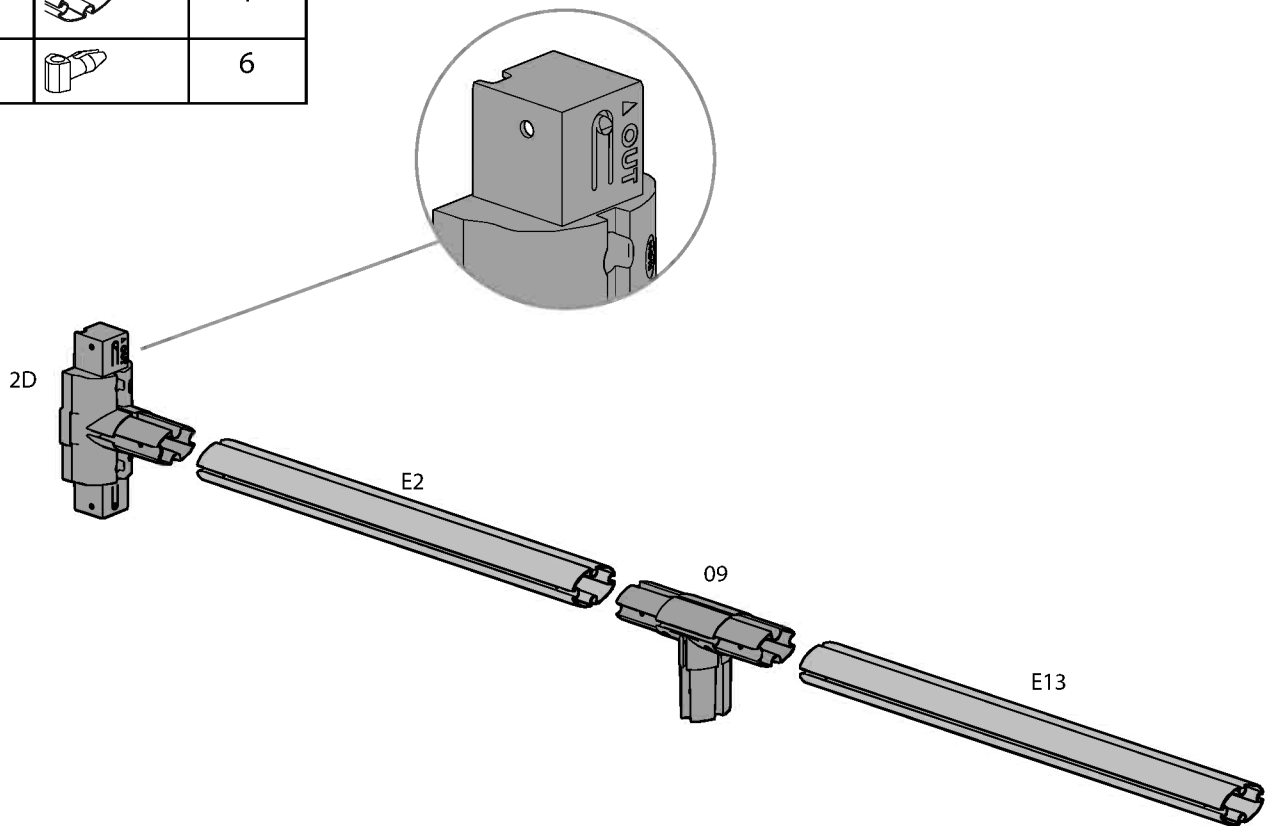
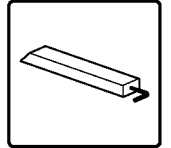

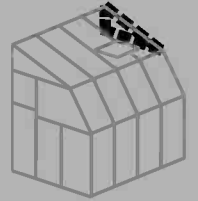

Item		Qty.
76		1
7617		1
pin1		6

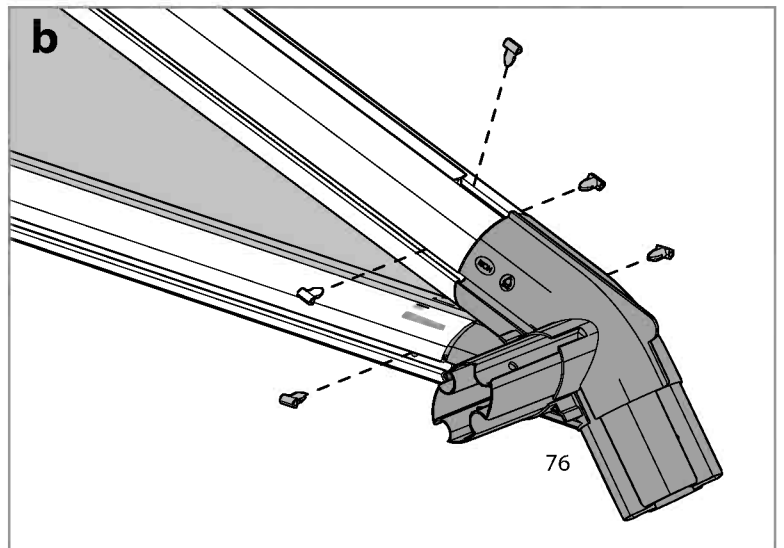
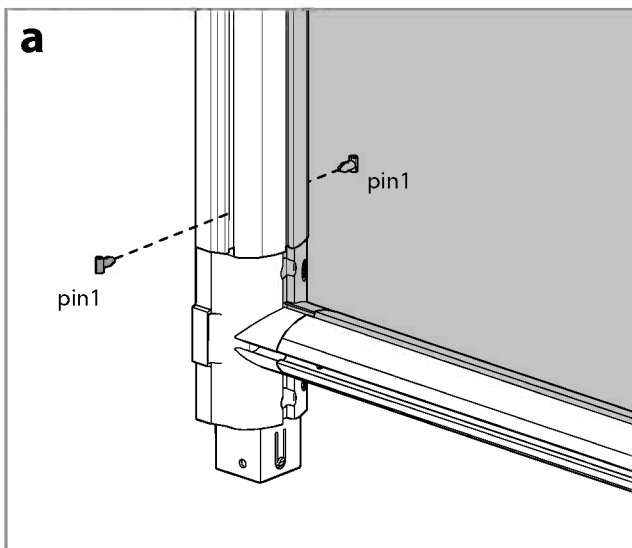
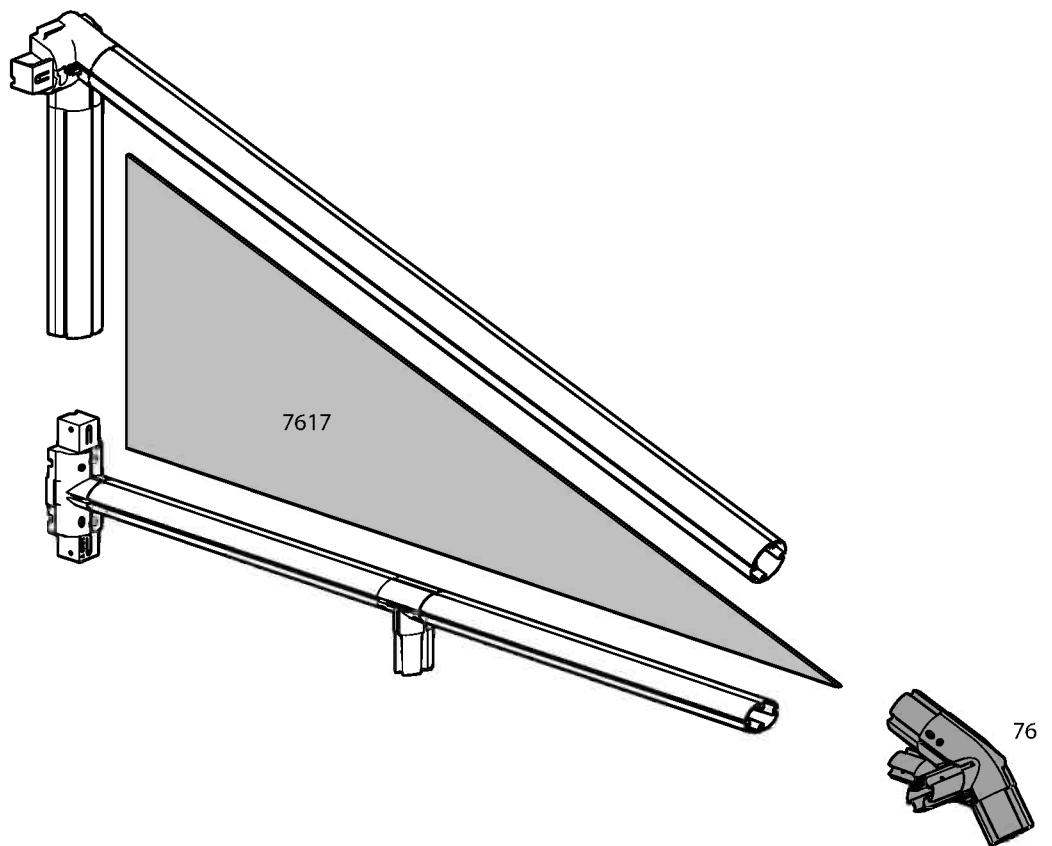
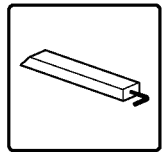

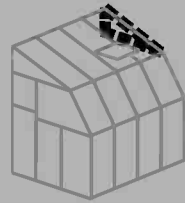

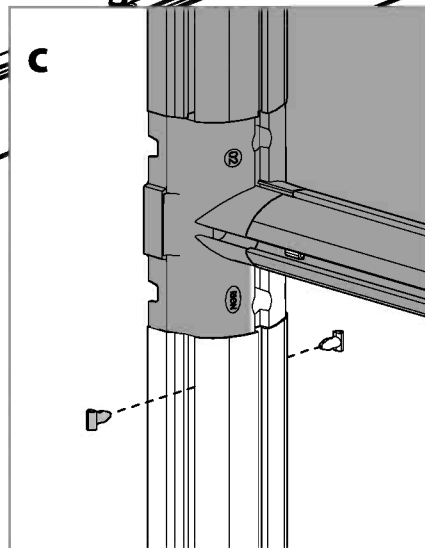
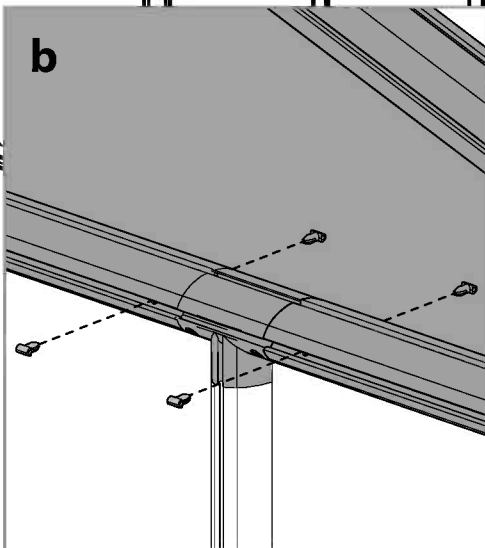
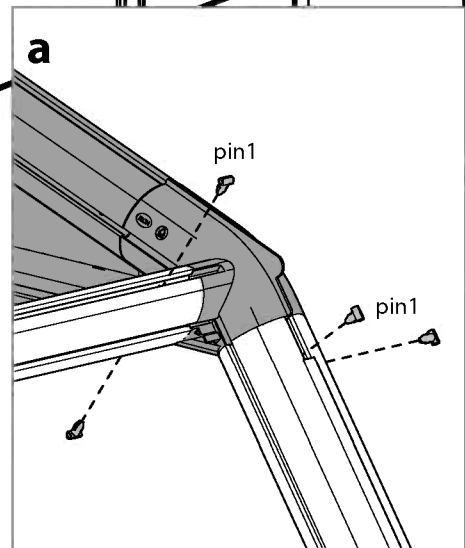
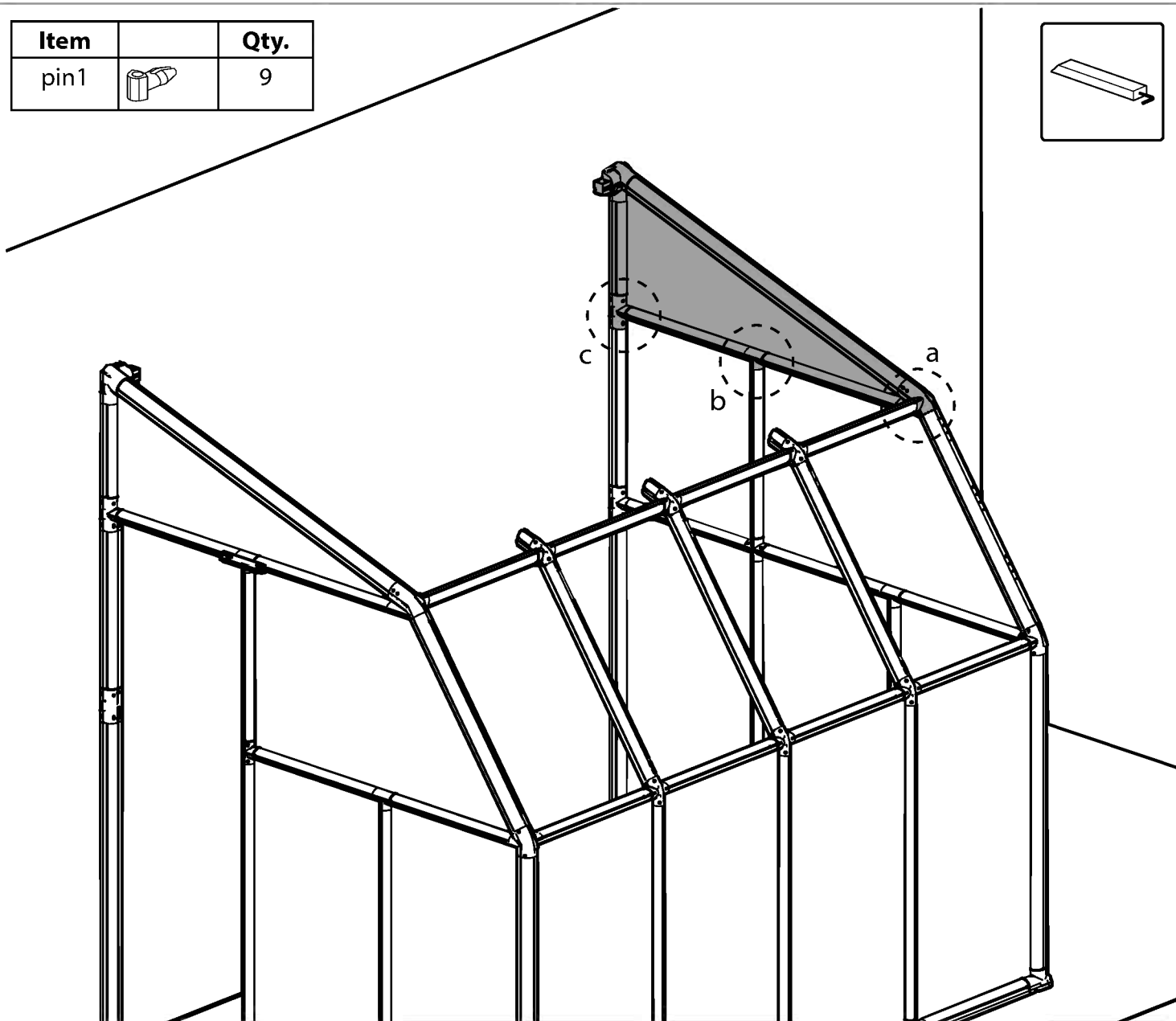
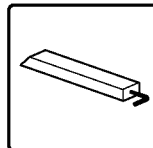

Item		Qty.
pin1		9

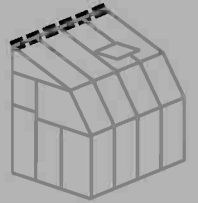





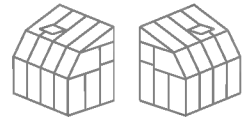
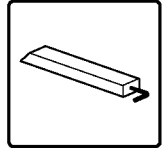

Item		Qty.
B2		4
14		3
pin1		16

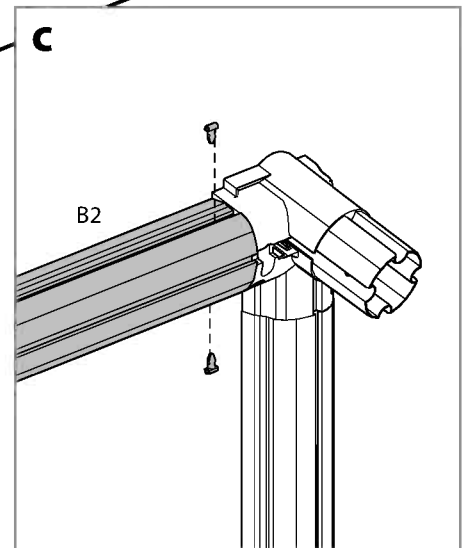
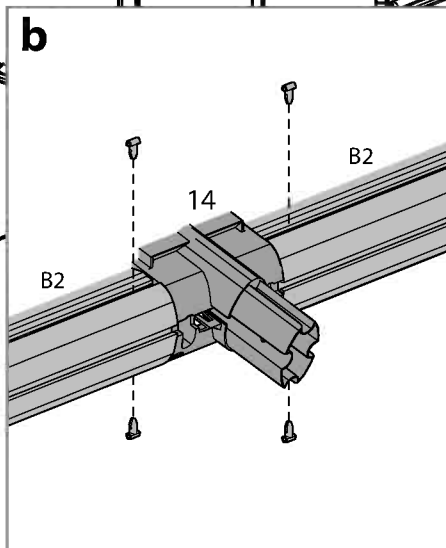
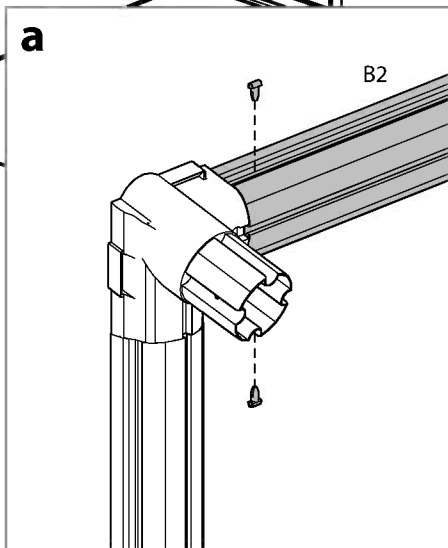
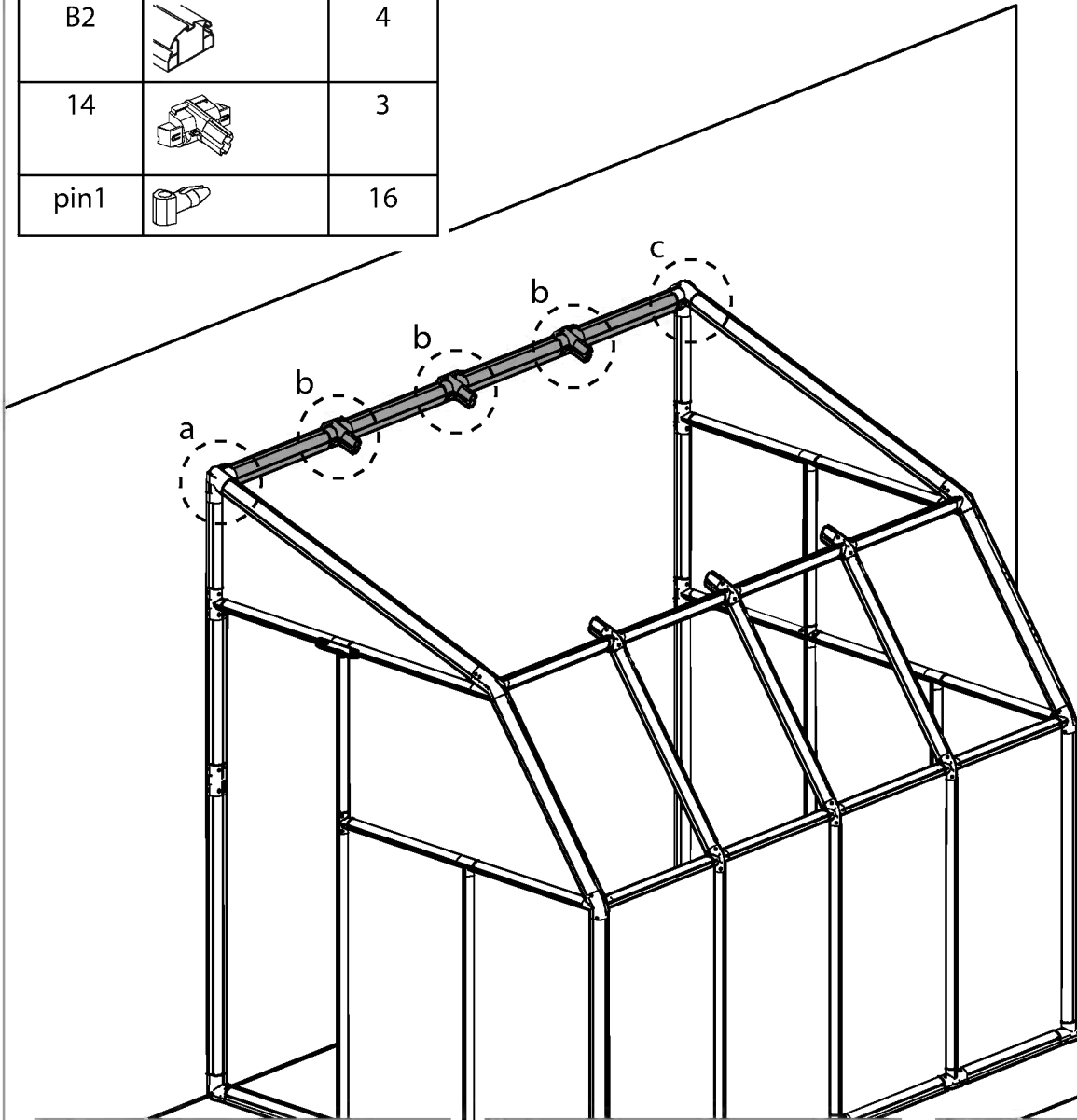

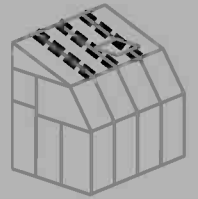
6'x8' = 4xB2  
 6'x10' = 5xB2





Item		Qty.
E16		3
7610		3
pin1		12

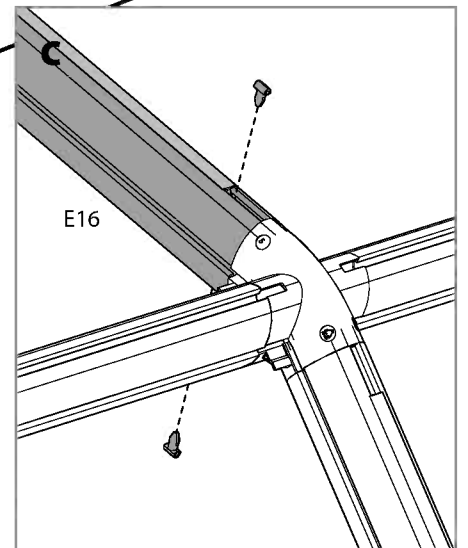
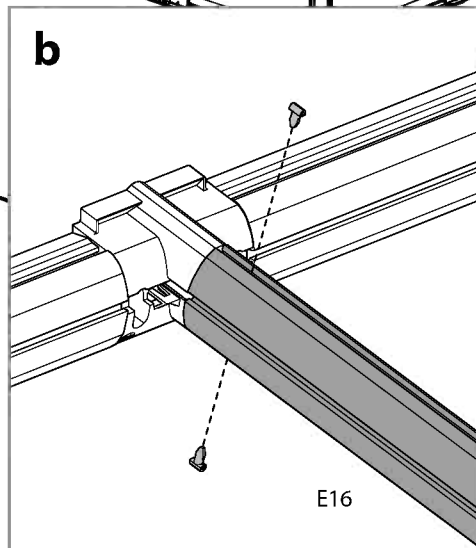
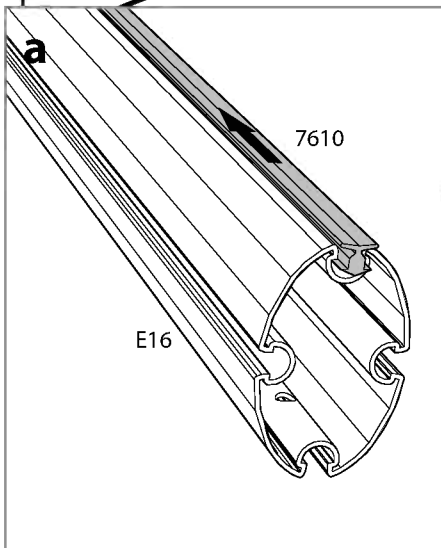
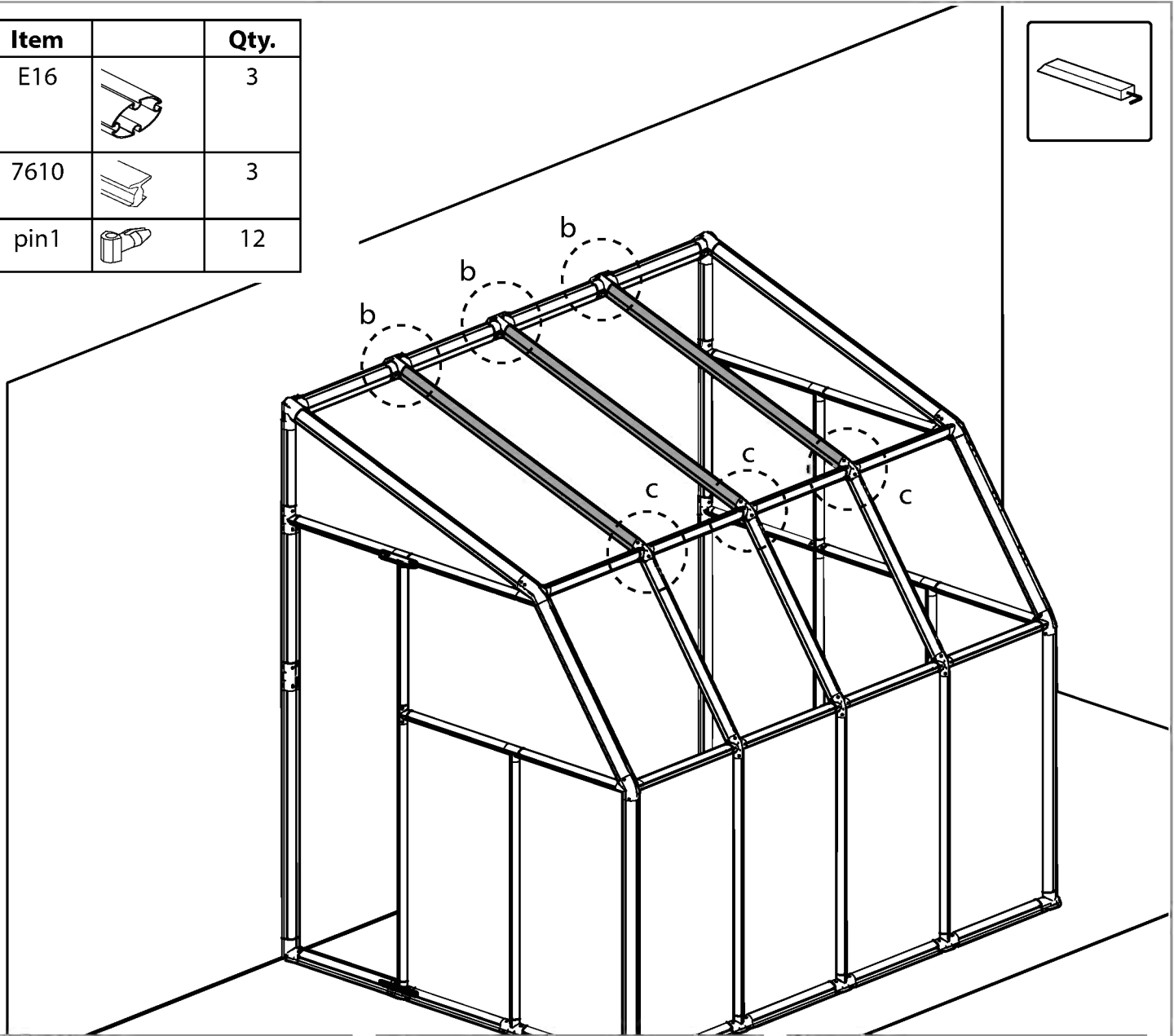
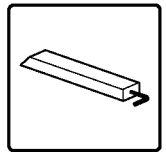

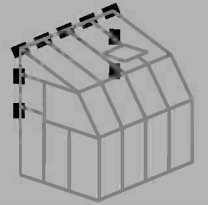

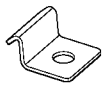
Item		Qty.
BC1		14

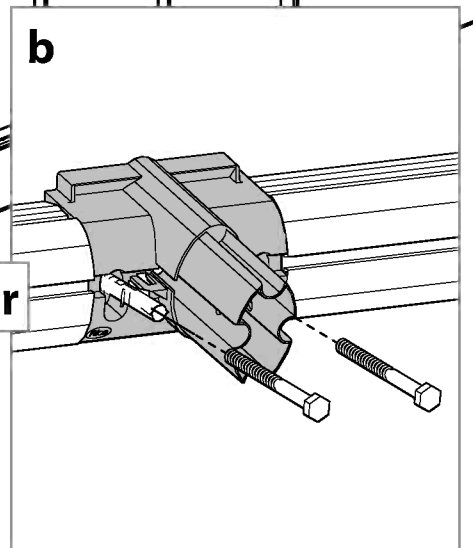
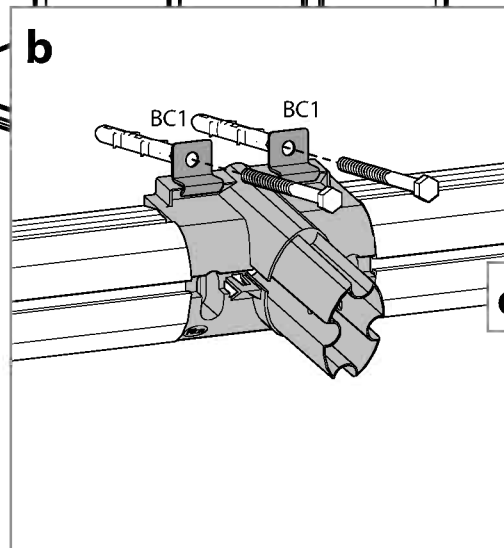
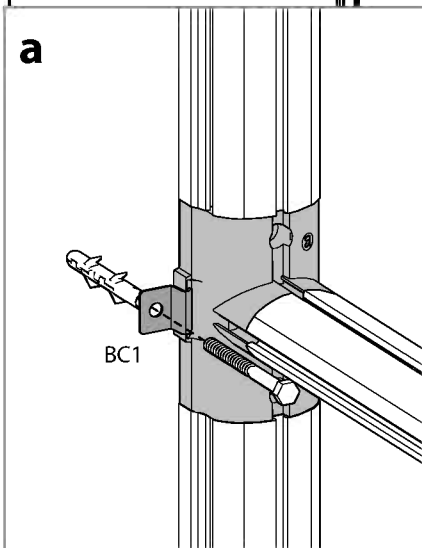
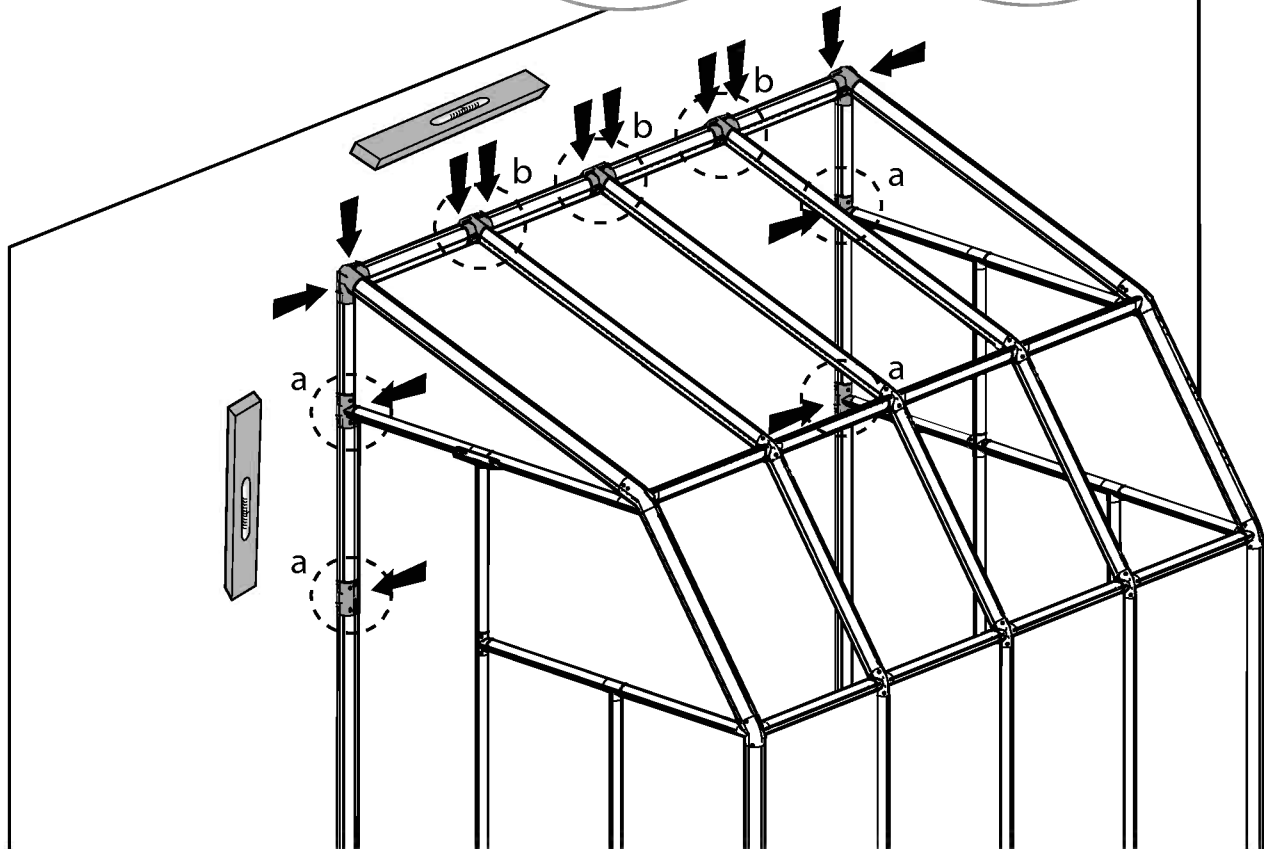
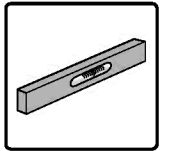
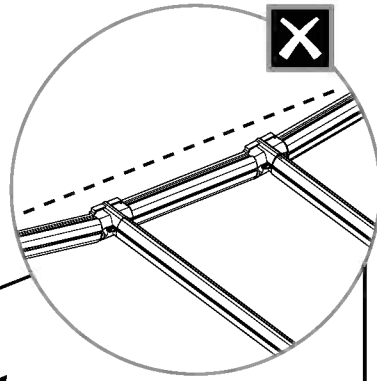
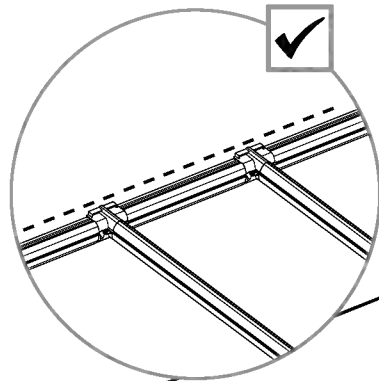

or

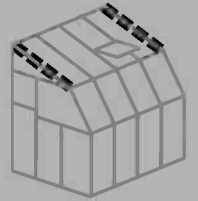

Item		Qty.
7611		2

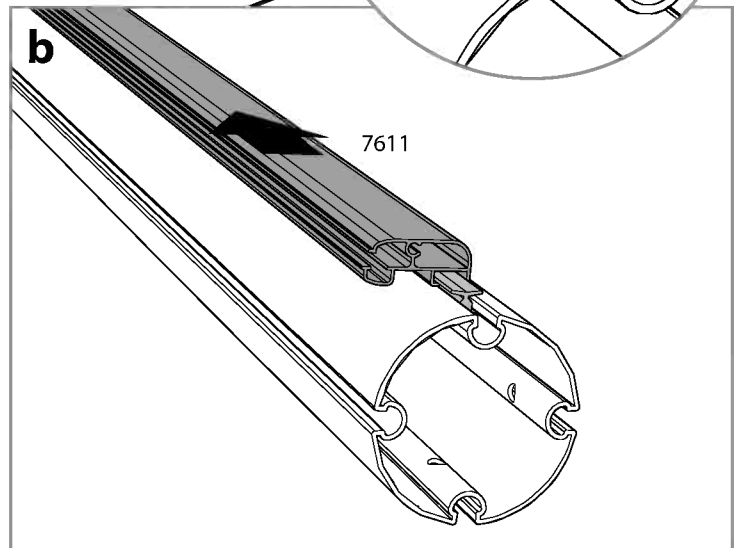
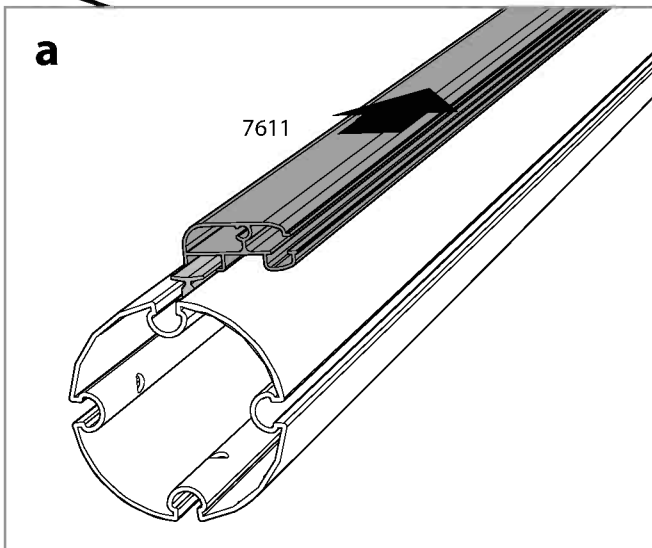
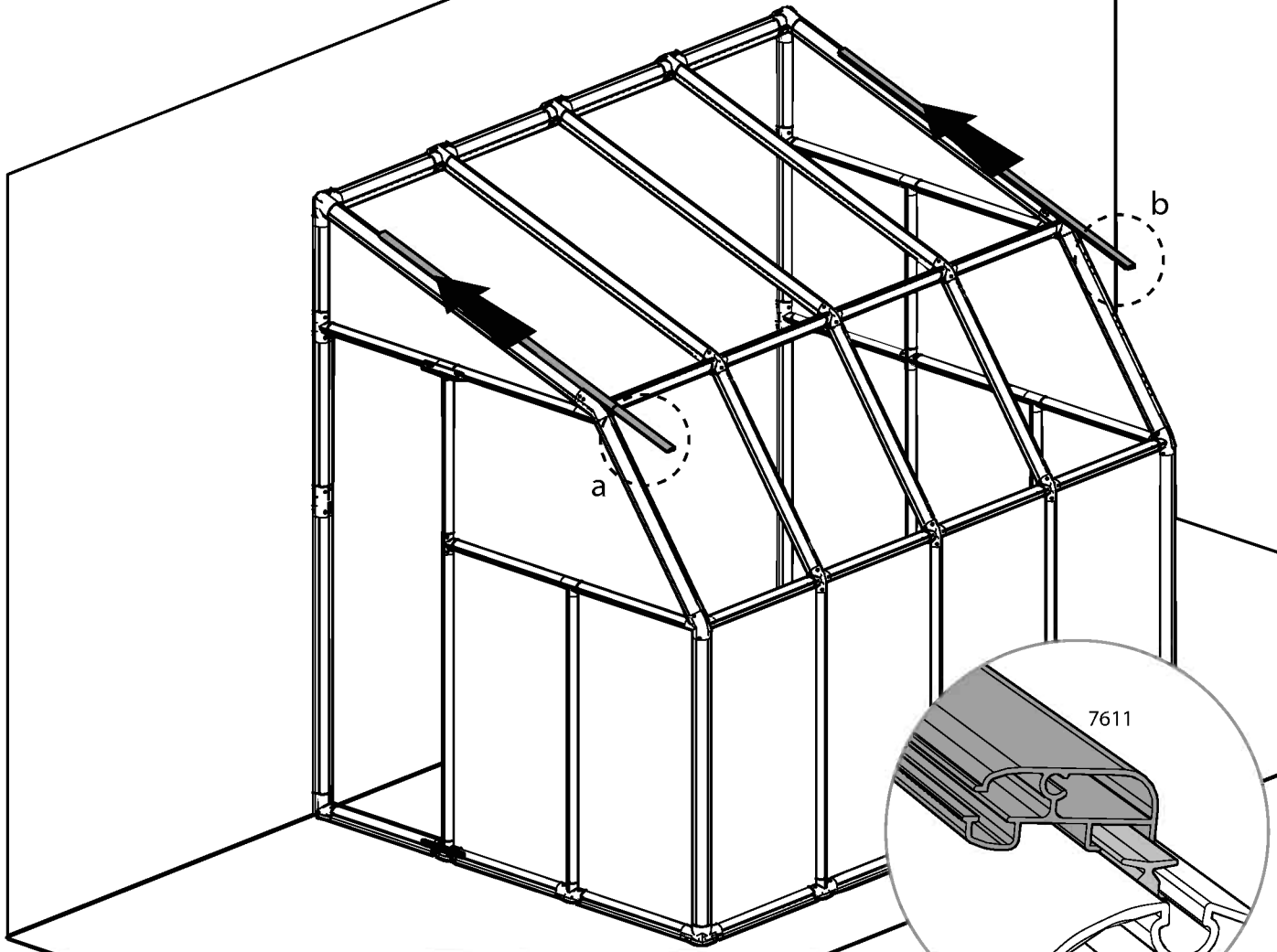

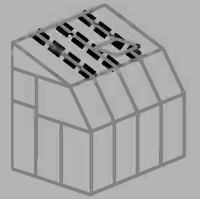

Item		Qty.
7613		3

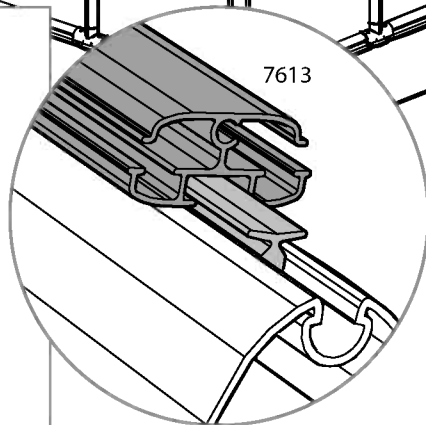
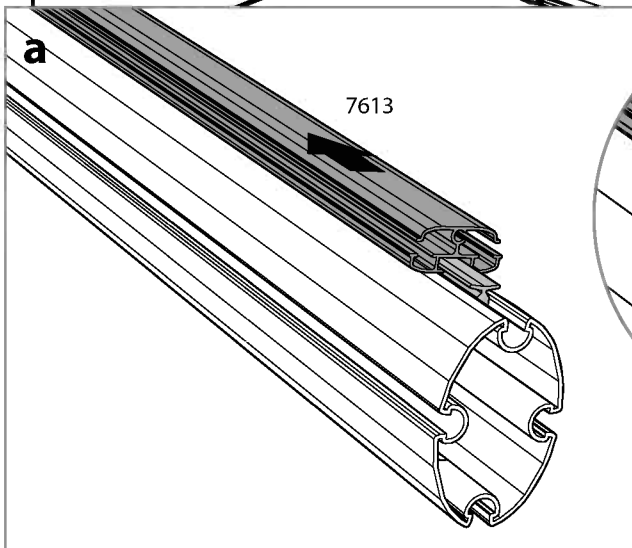
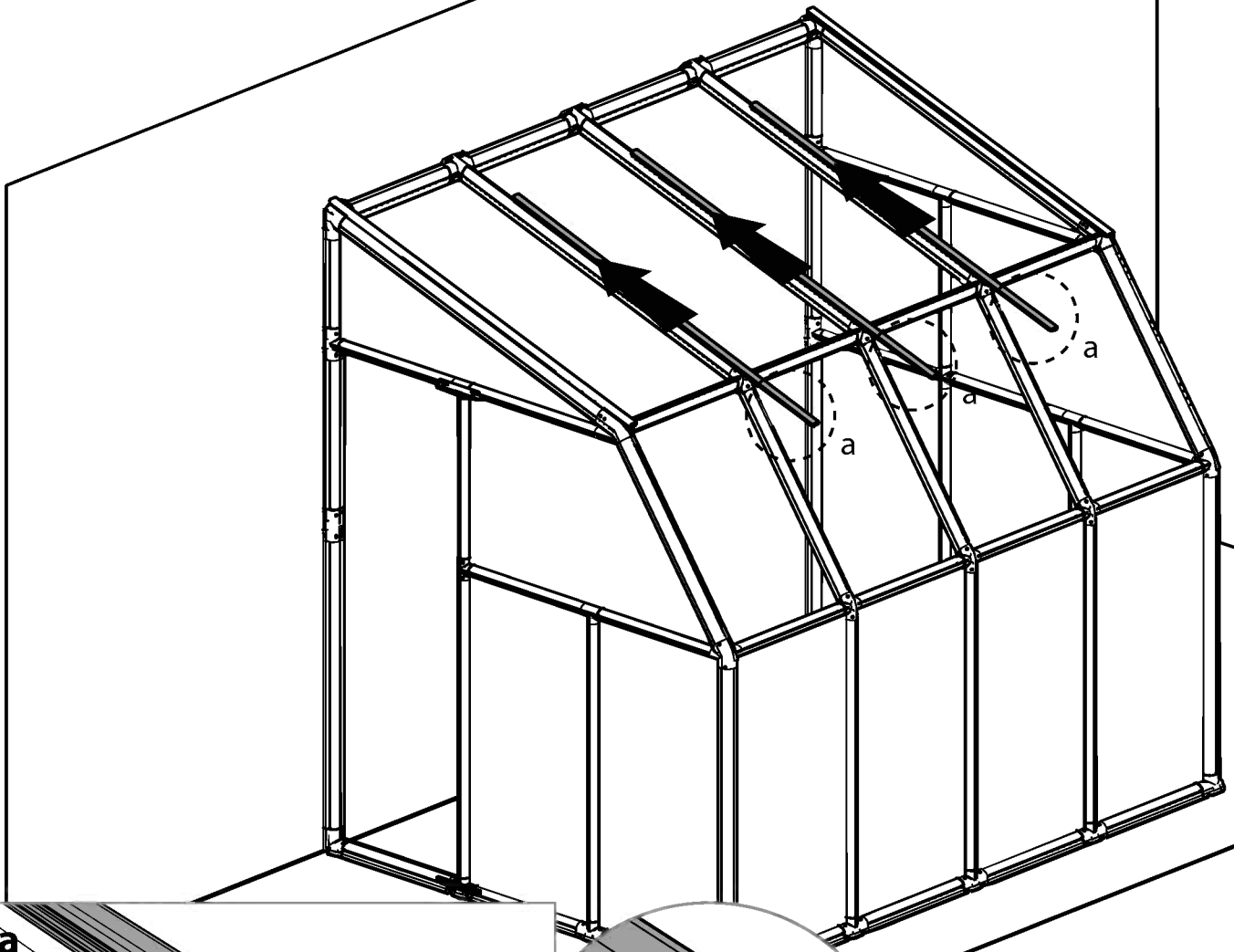

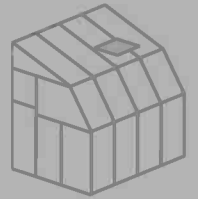



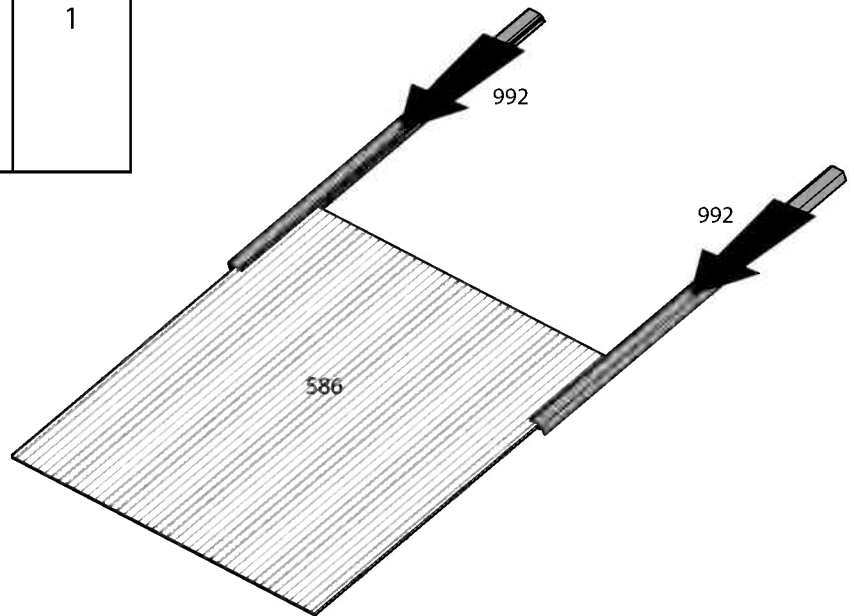
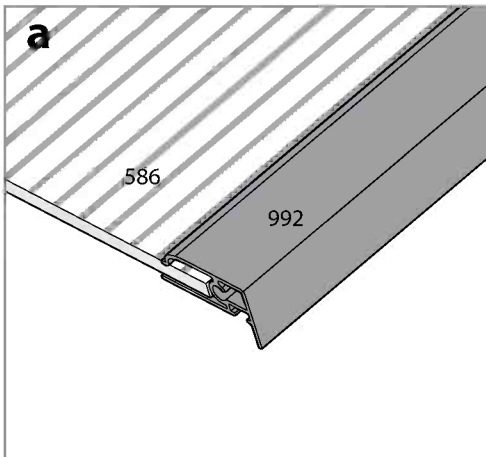

Item		Qty.
992		2
586		1

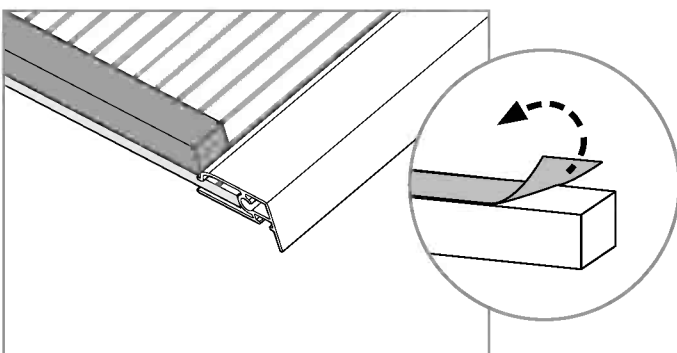
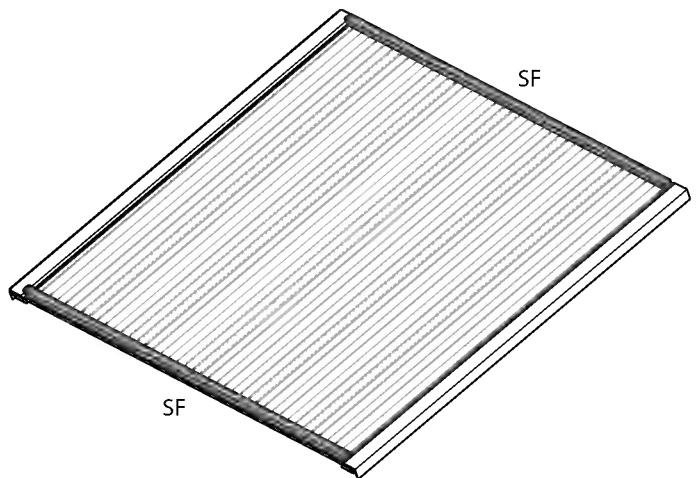
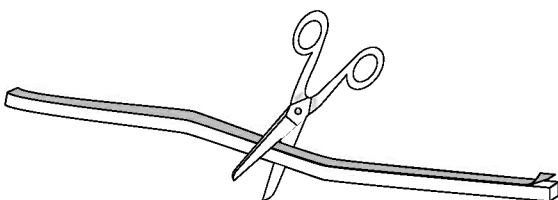
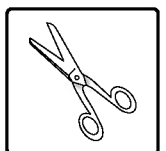

Item		Qty.
SF		1





Item		Qty.
989		1
991		1
4008		4
411		2

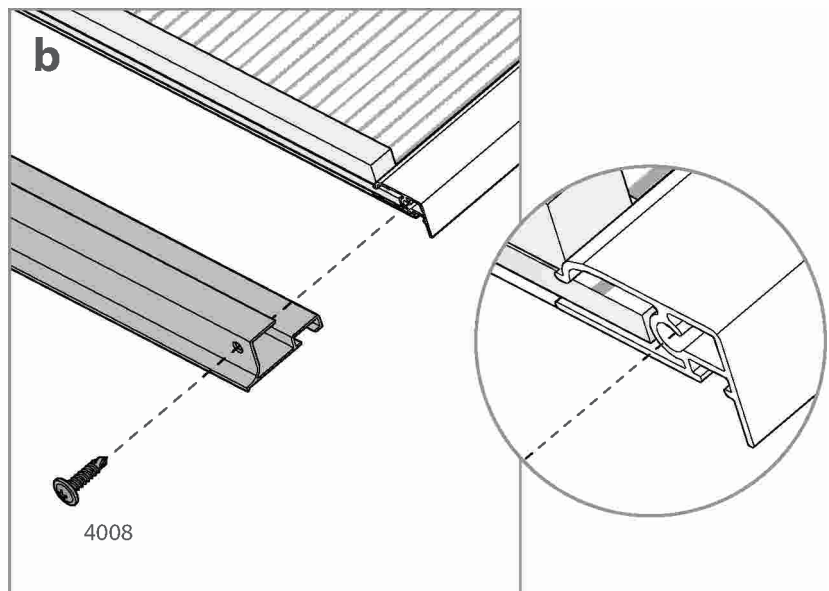
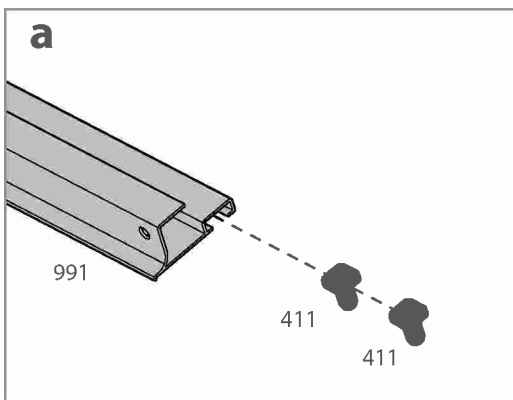
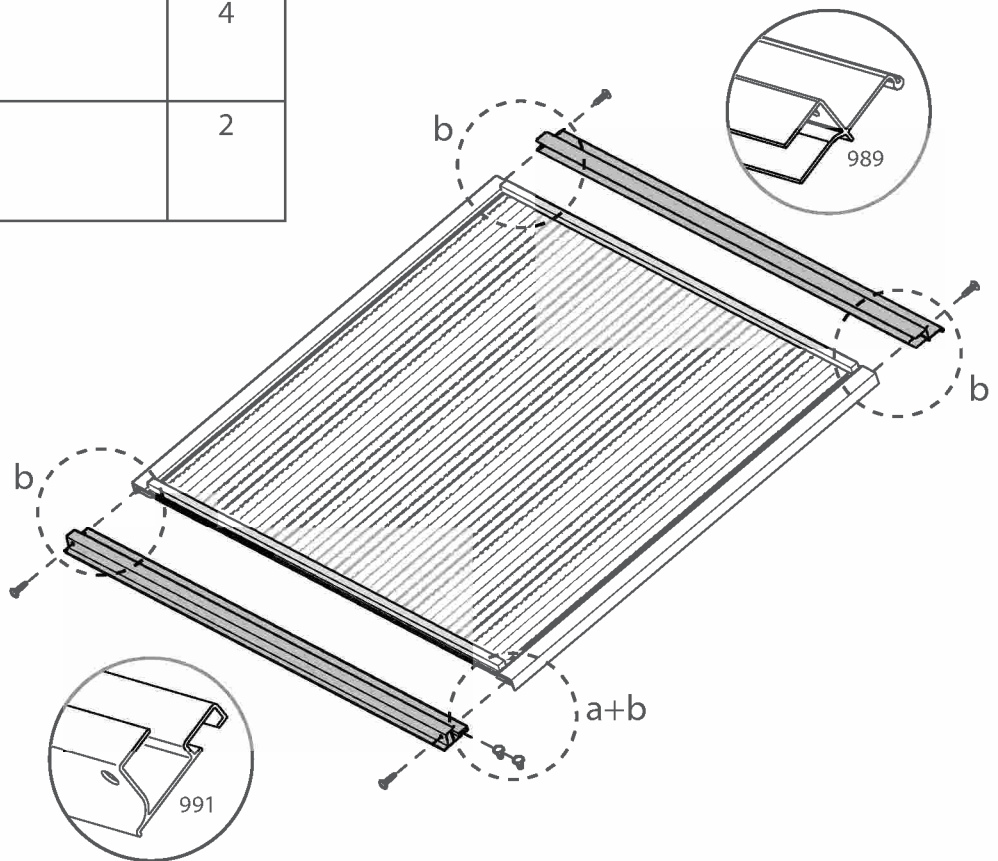
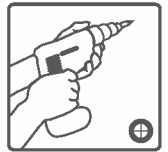



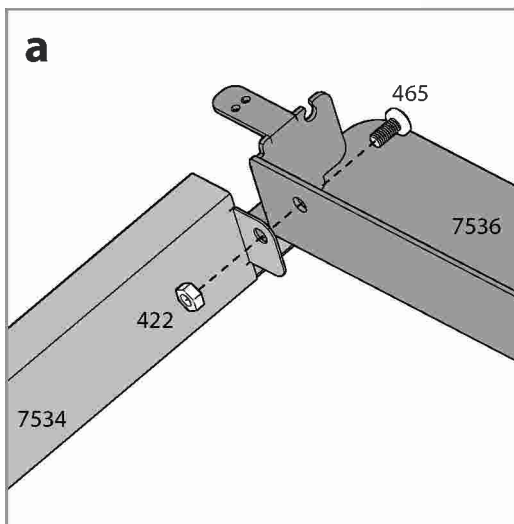
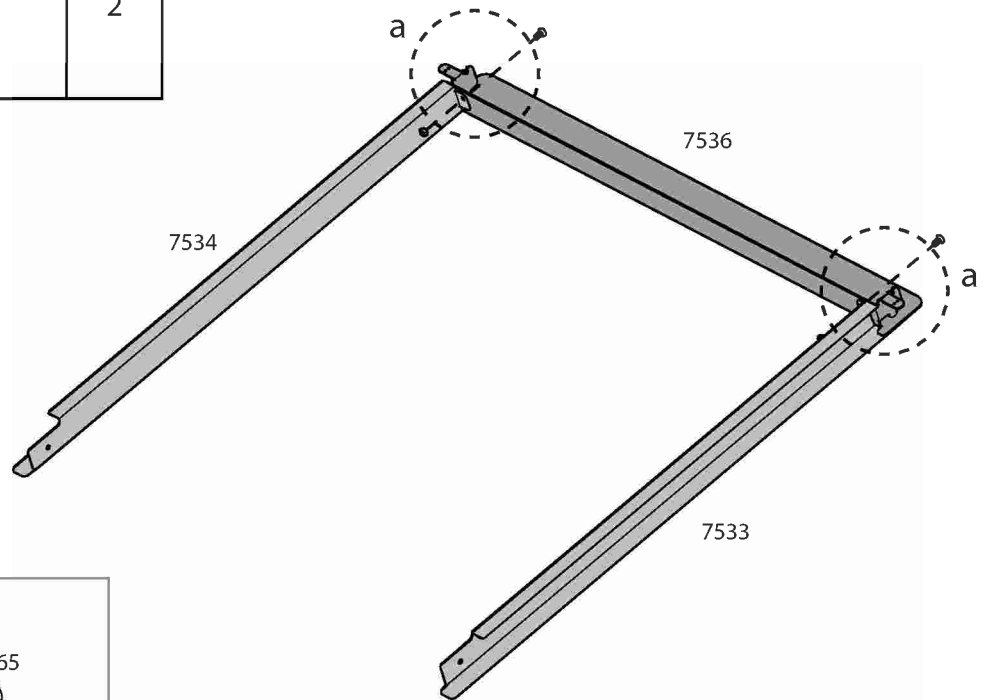
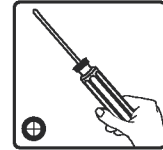

Item		Qty.
7536		1
7533		1
7534		1
465	M4x8mm	2
422	M4	2

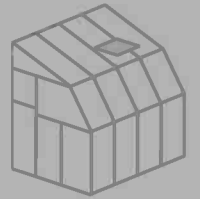

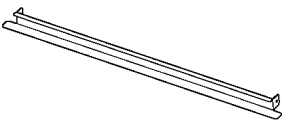

Item		Qty.
7535		1
465	 M4x8mm	2
422	 M4	2

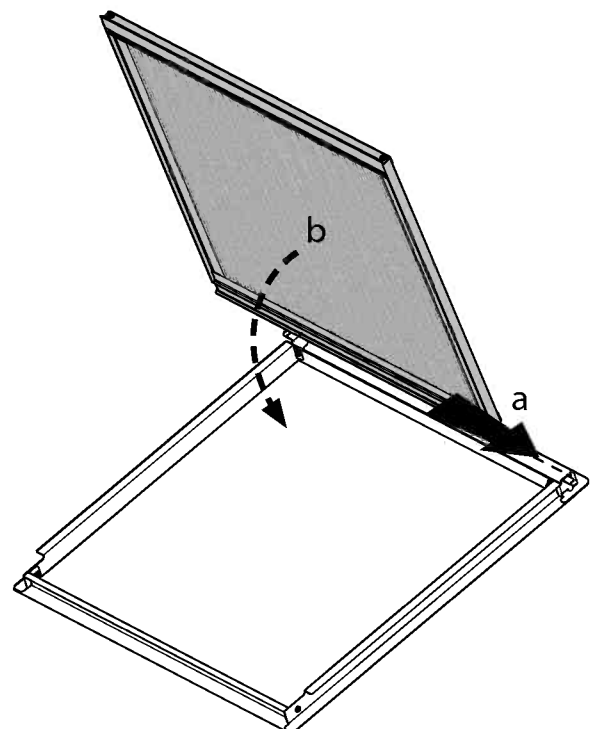
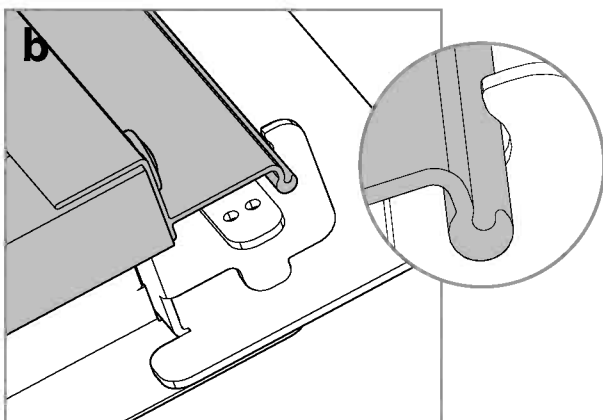
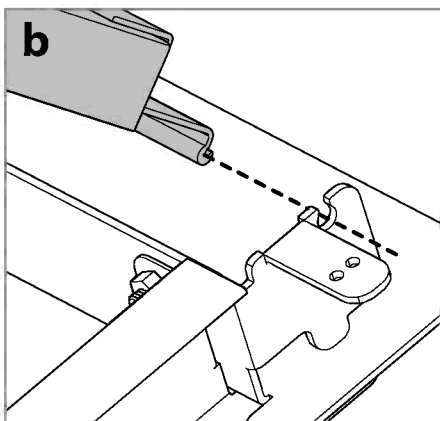
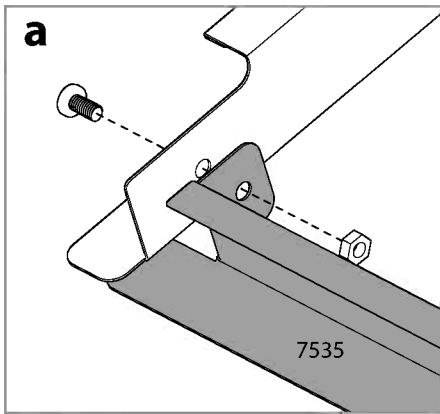
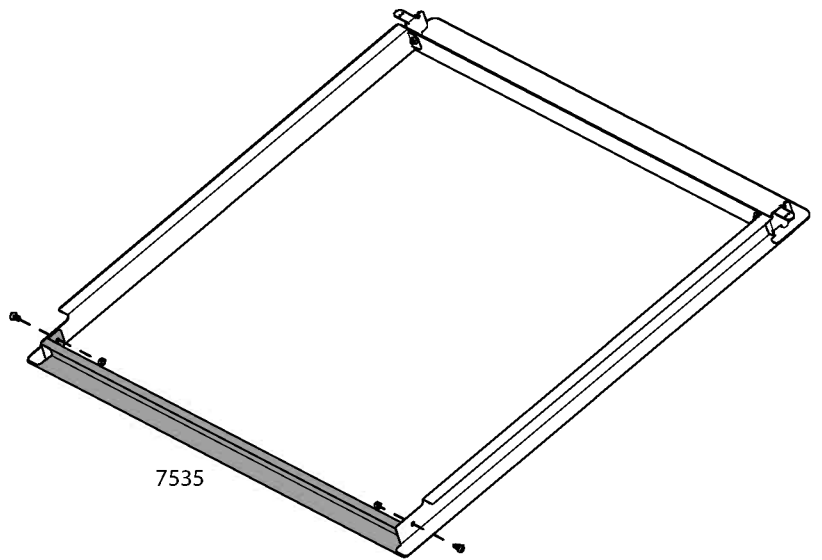
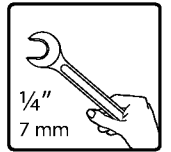
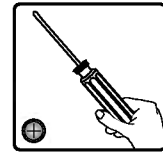

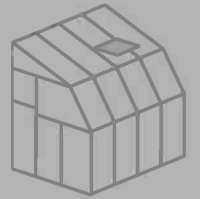

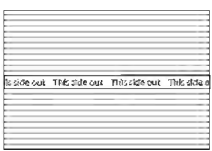
Item		Qty.
7630		1

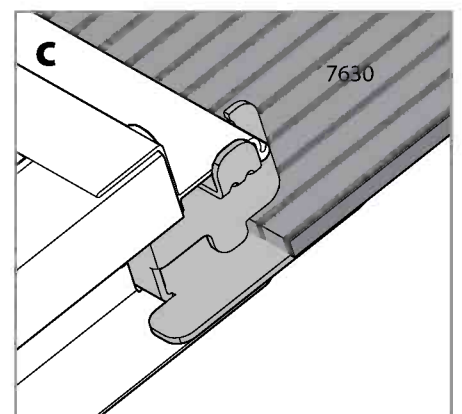
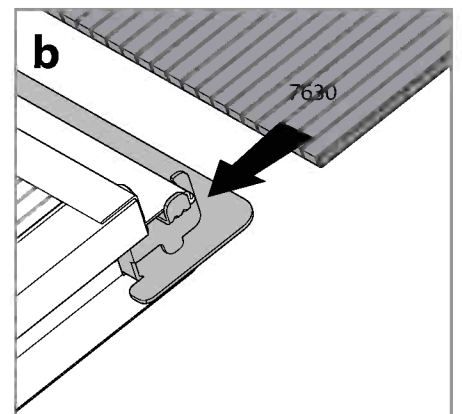
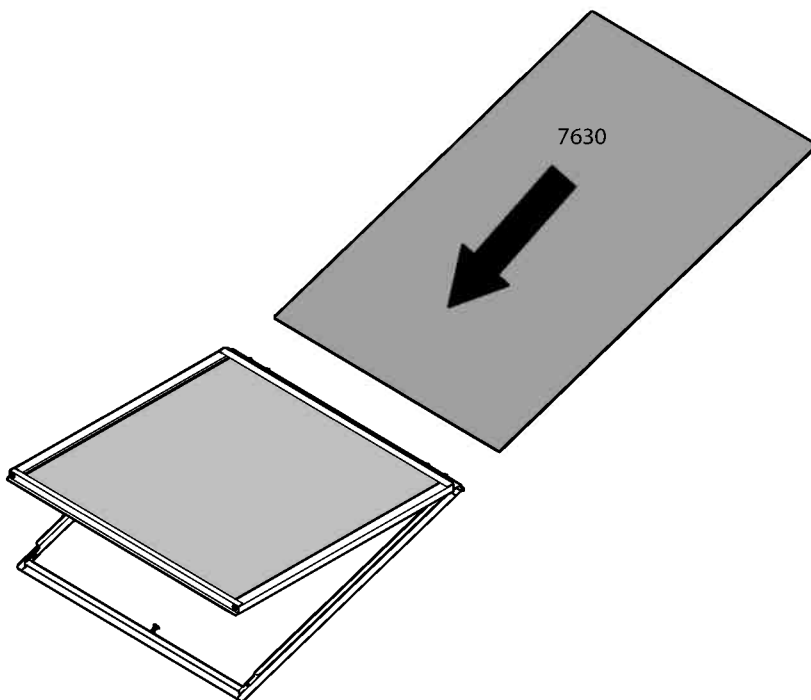
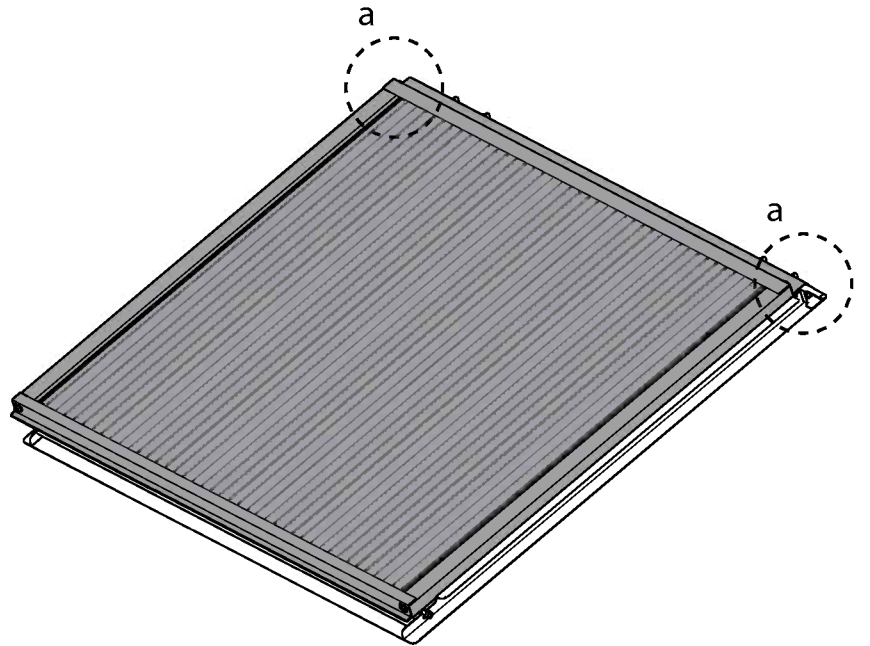
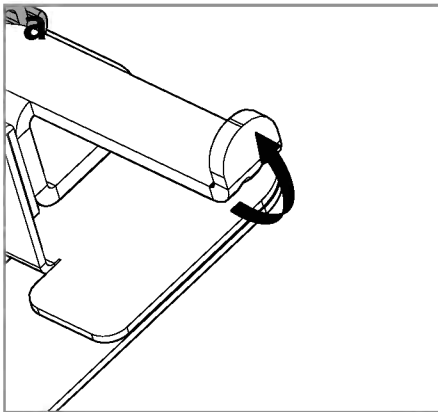
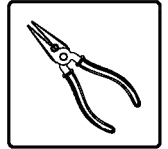



- EN** Windows Location
- DE** Fenster Standort
- FR** Fenêtre Emplacement
- ES** Ventana Ubicación

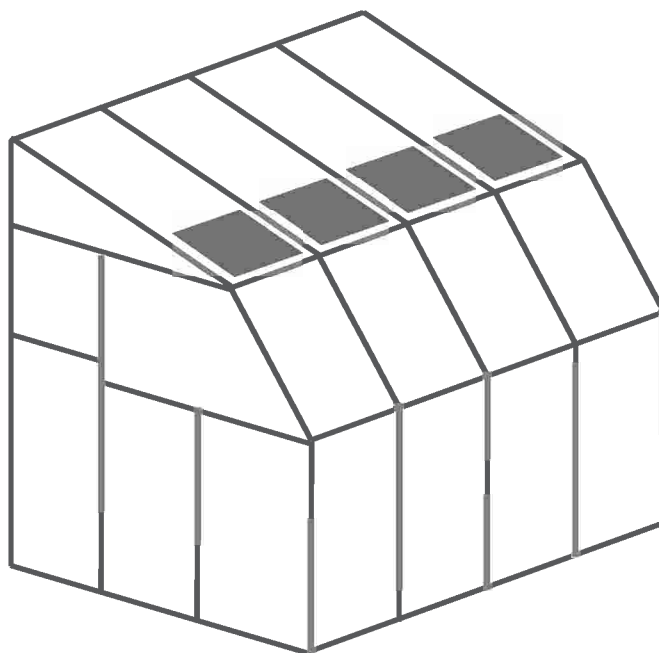
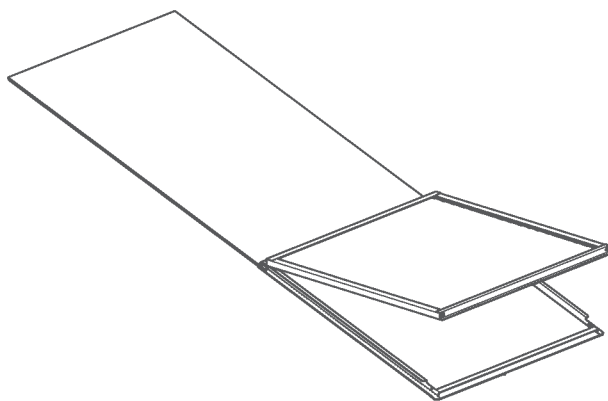

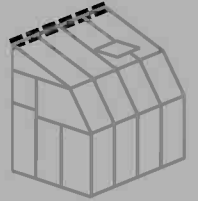

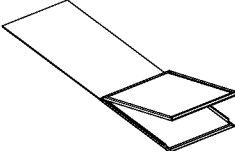
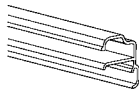
Item		Qty.
PN57		3
Window		1
981		4

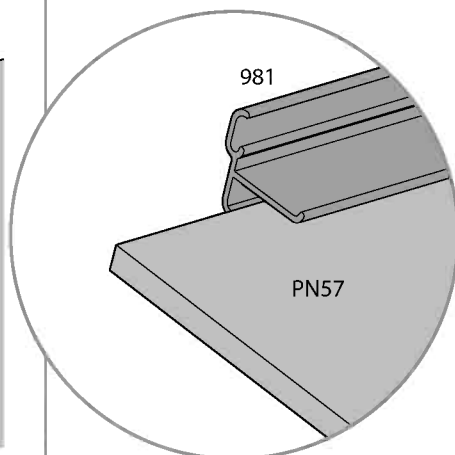
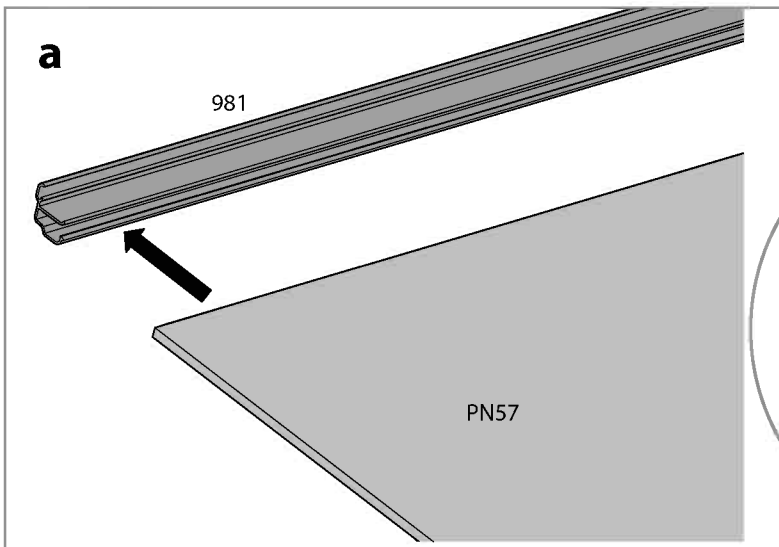
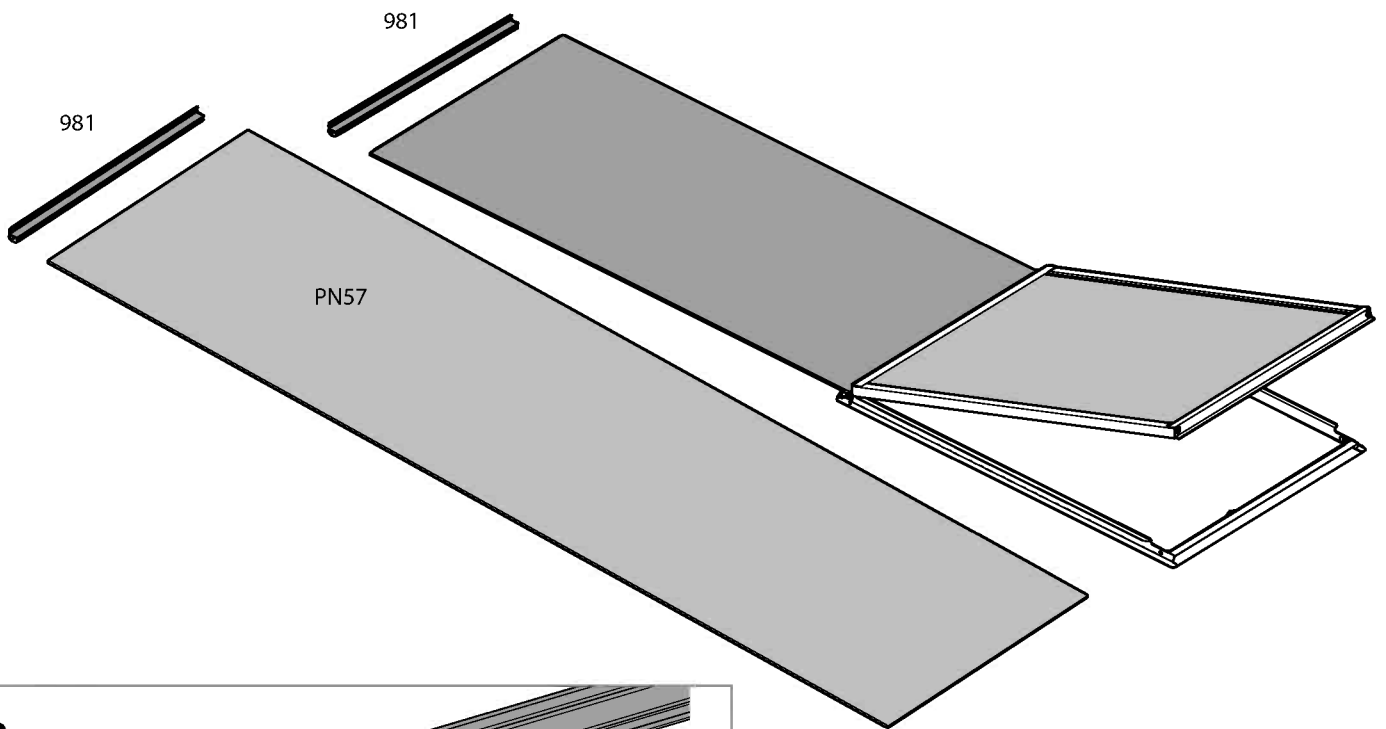

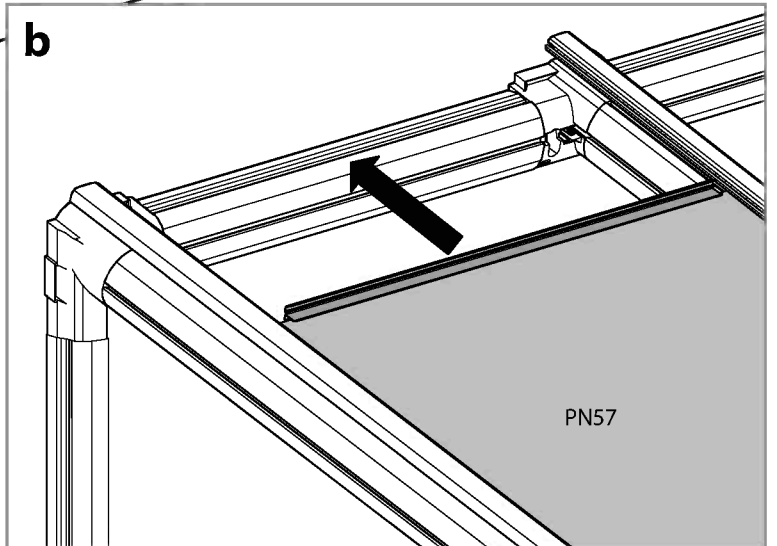
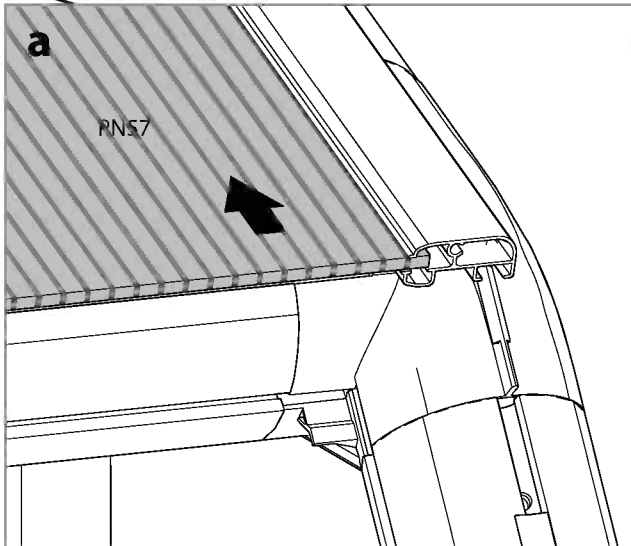
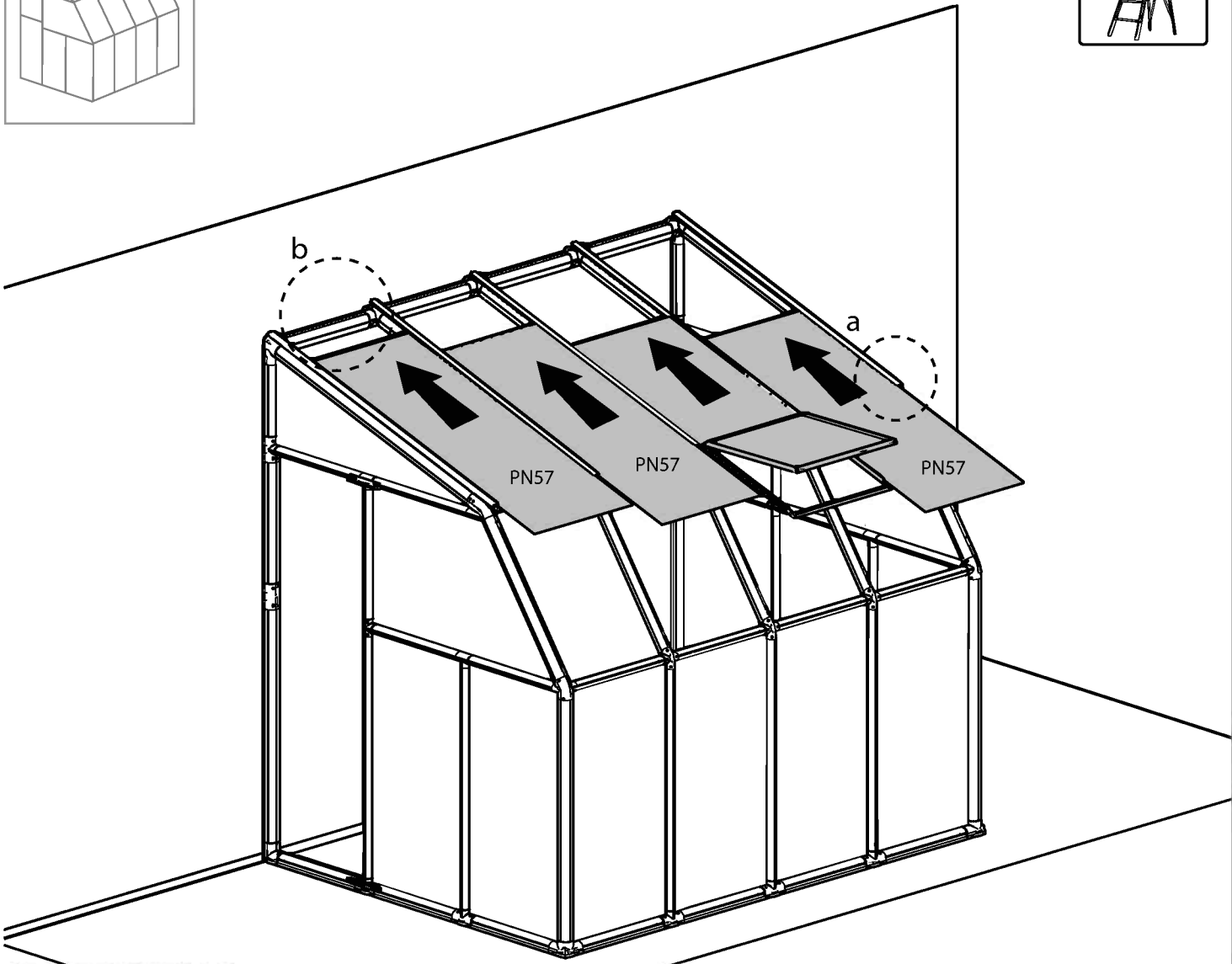
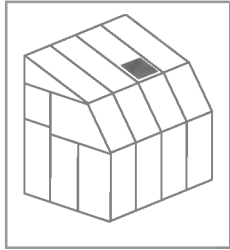
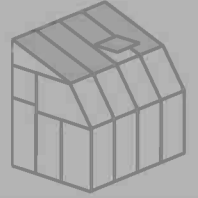

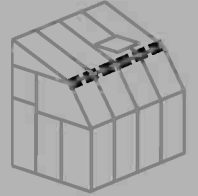

Item		Qty.
7552		3
7552F		1

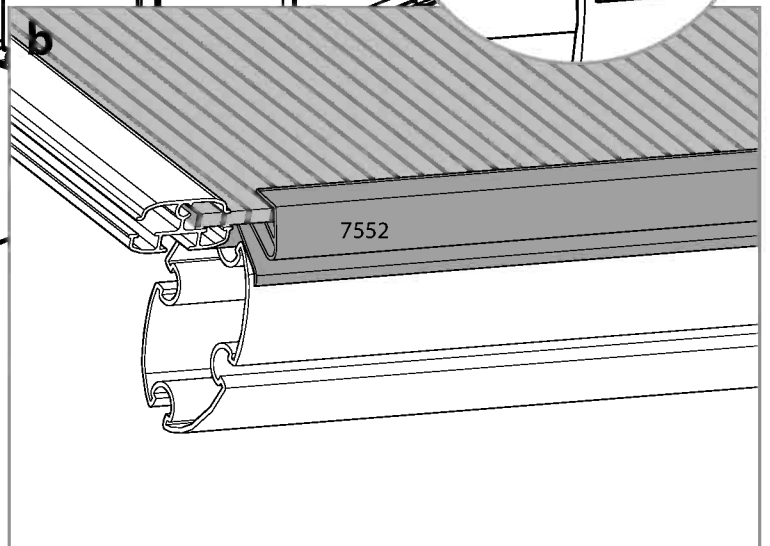
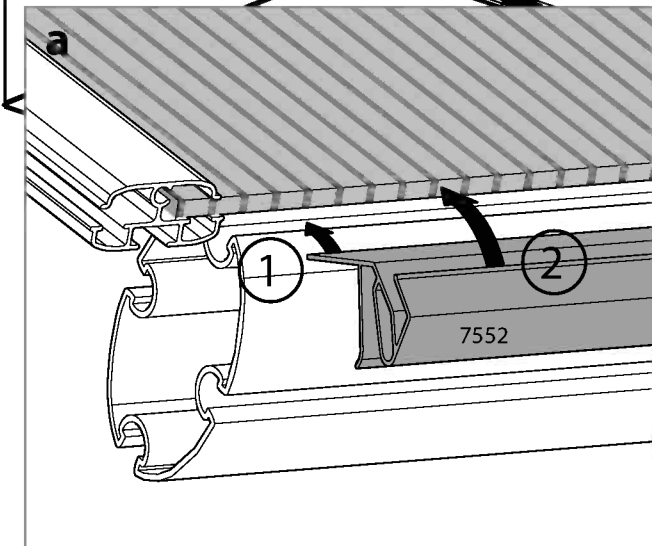
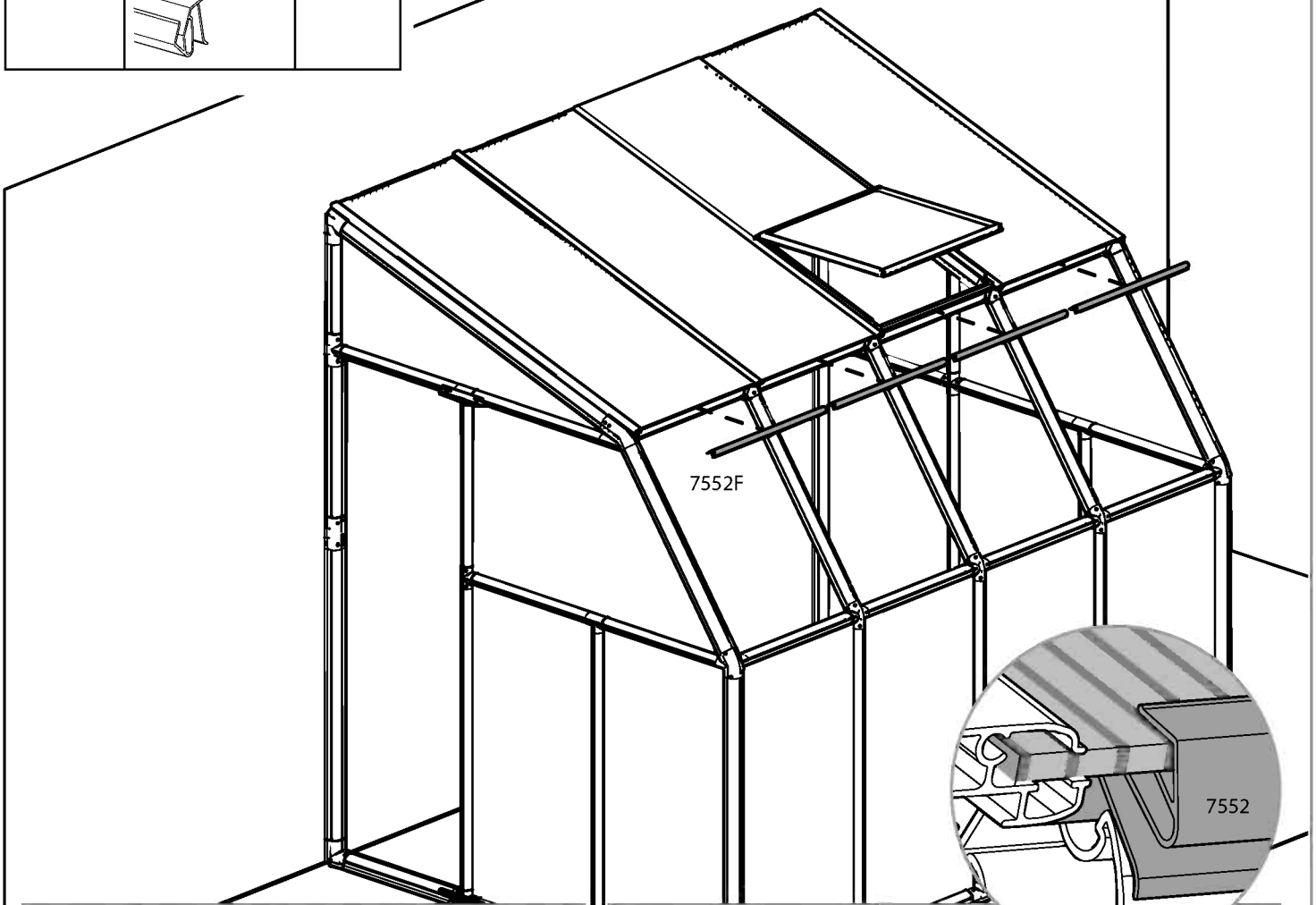
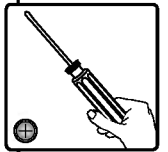

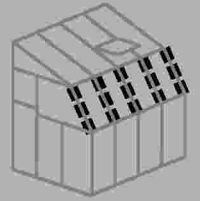

Item		Qty.
72		1
73		1
74		3
7612		2
7614		3
4043		5

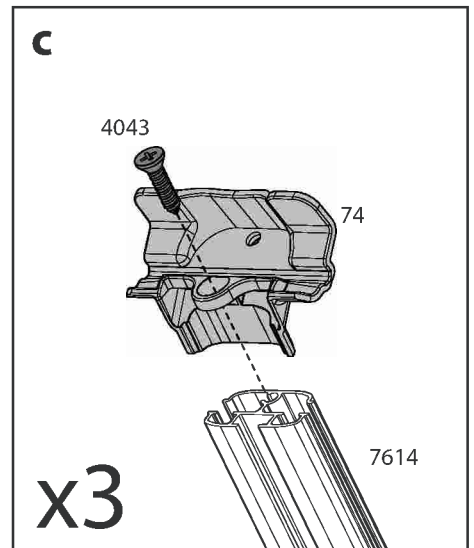
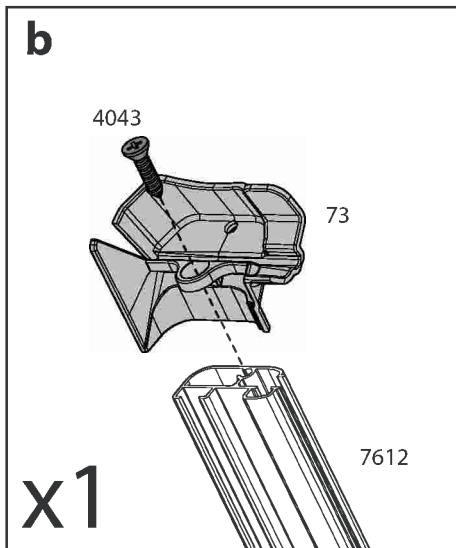
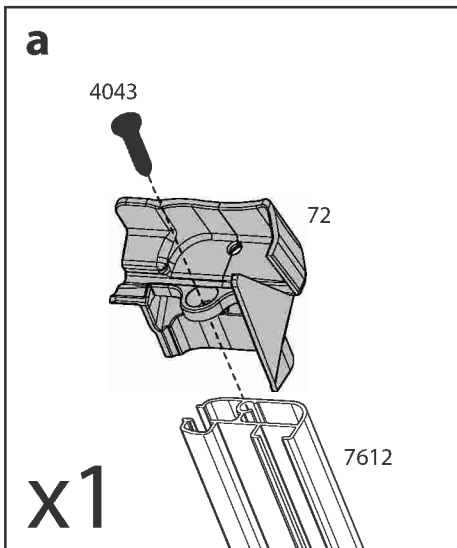
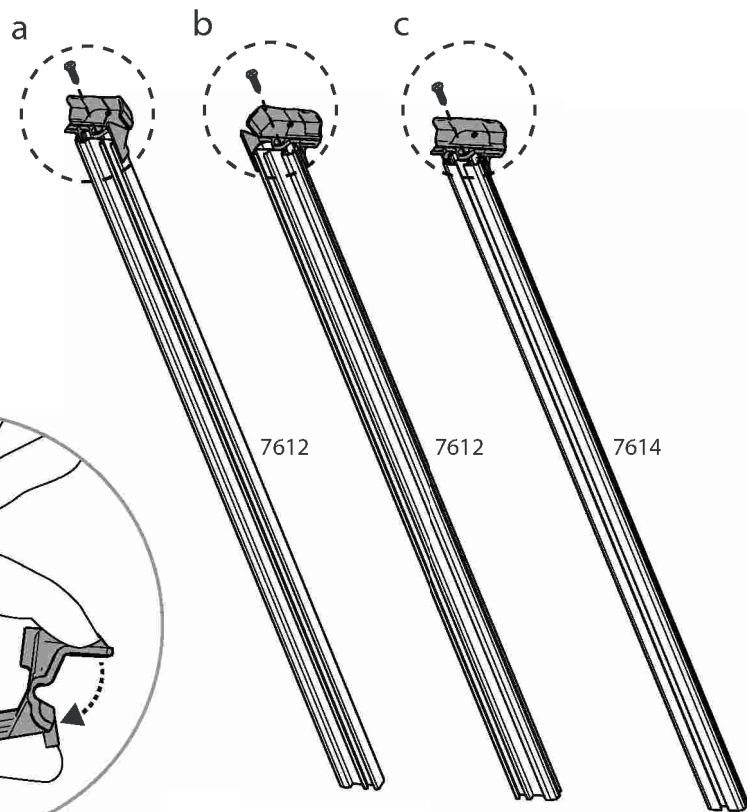
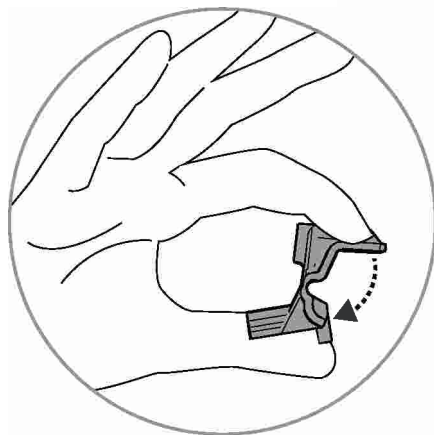
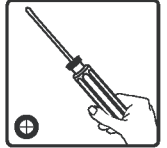

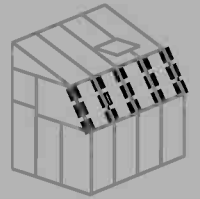

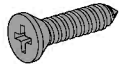

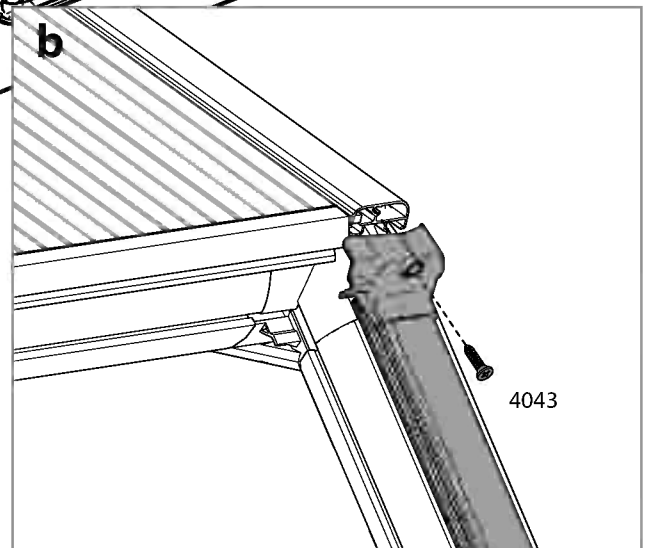
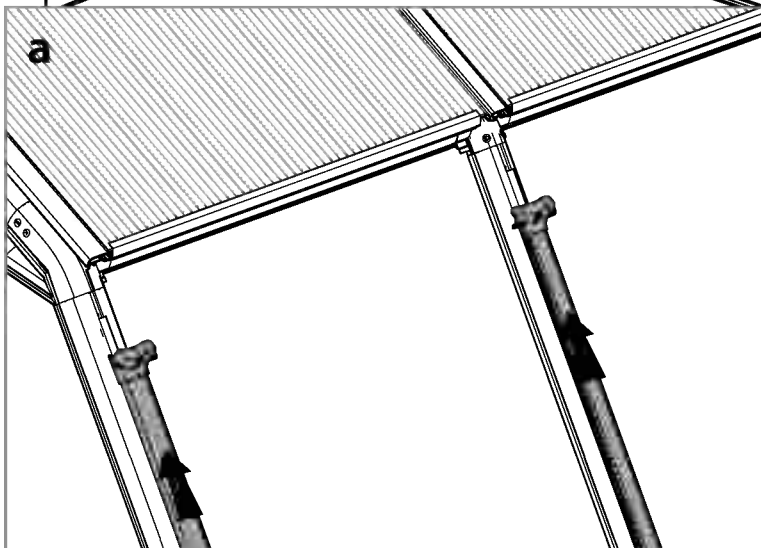
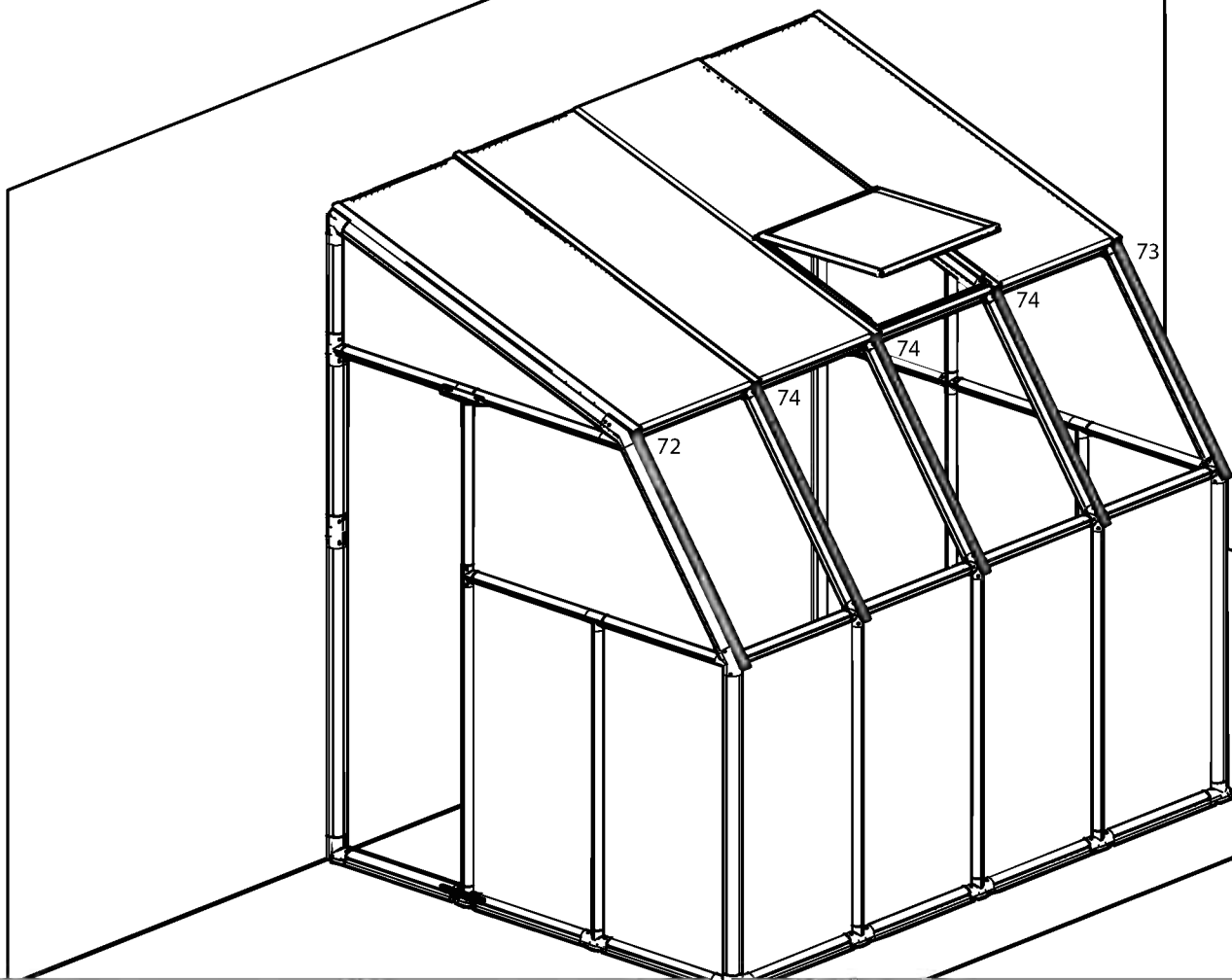
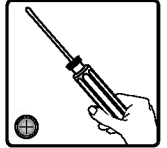
Item		Qty.
4043		5

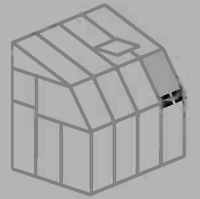

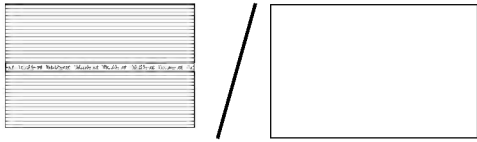
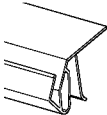

Item		Qty.
PN55		1
7552		1
4043		1
73		1

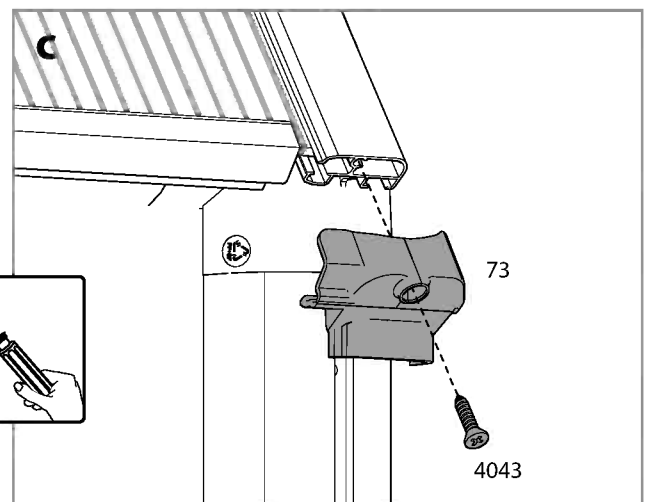
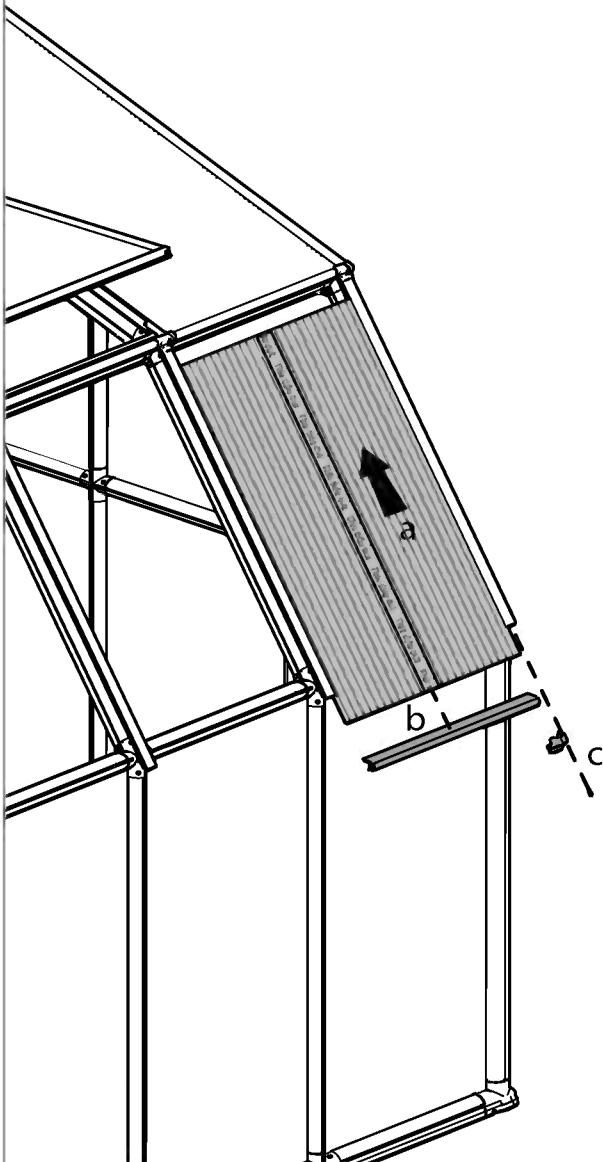
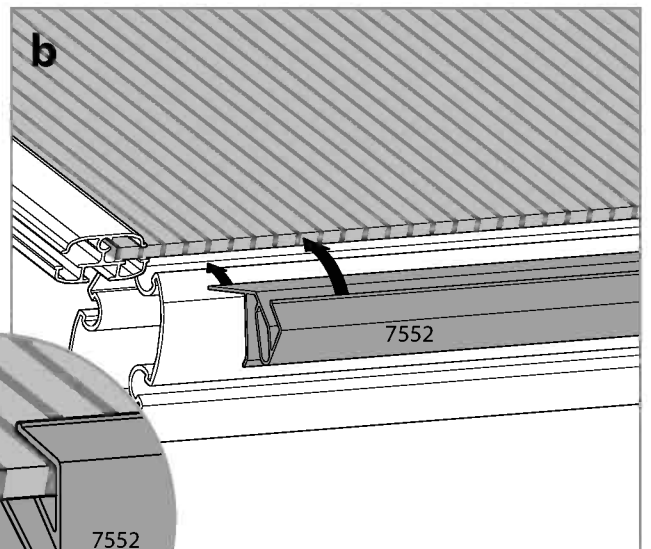
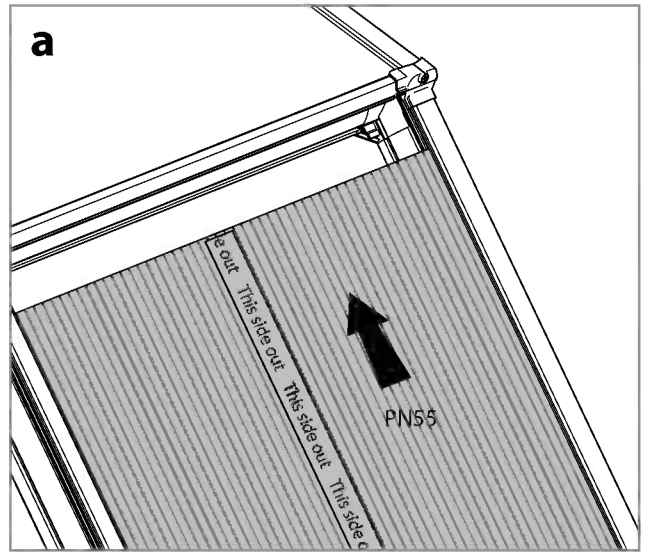

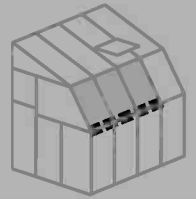

Item		Qty.
PN55		3
7552		2
7552F		1

Item		Qty.
4043		4
72		1
74		3

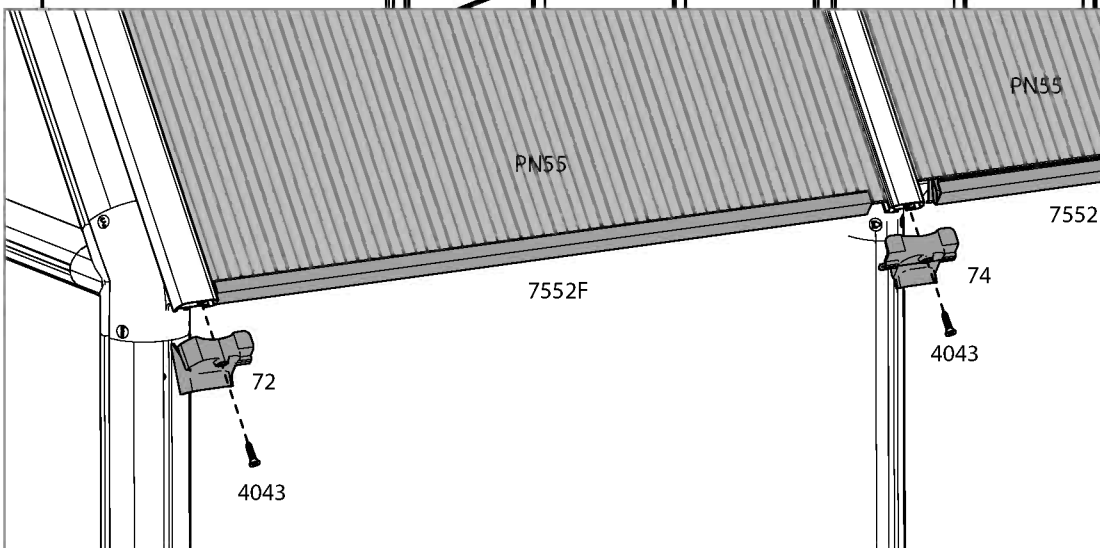
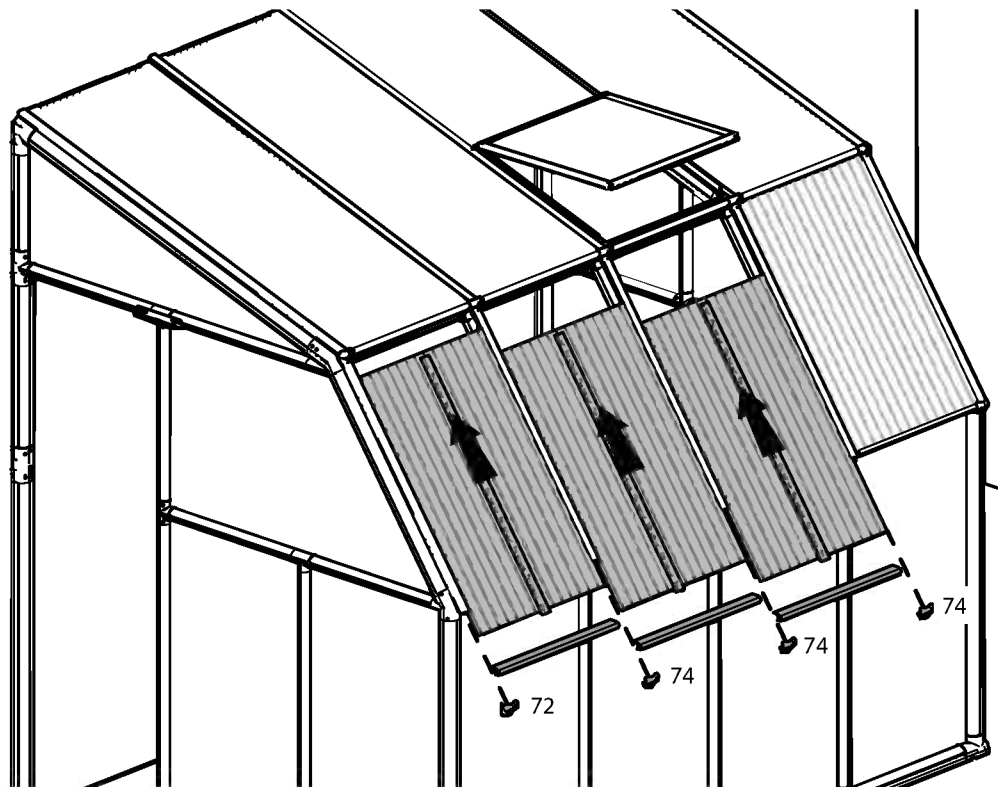
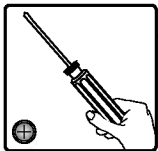

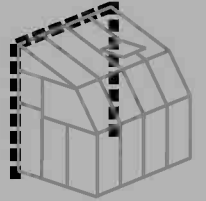

CAULK / SILICON

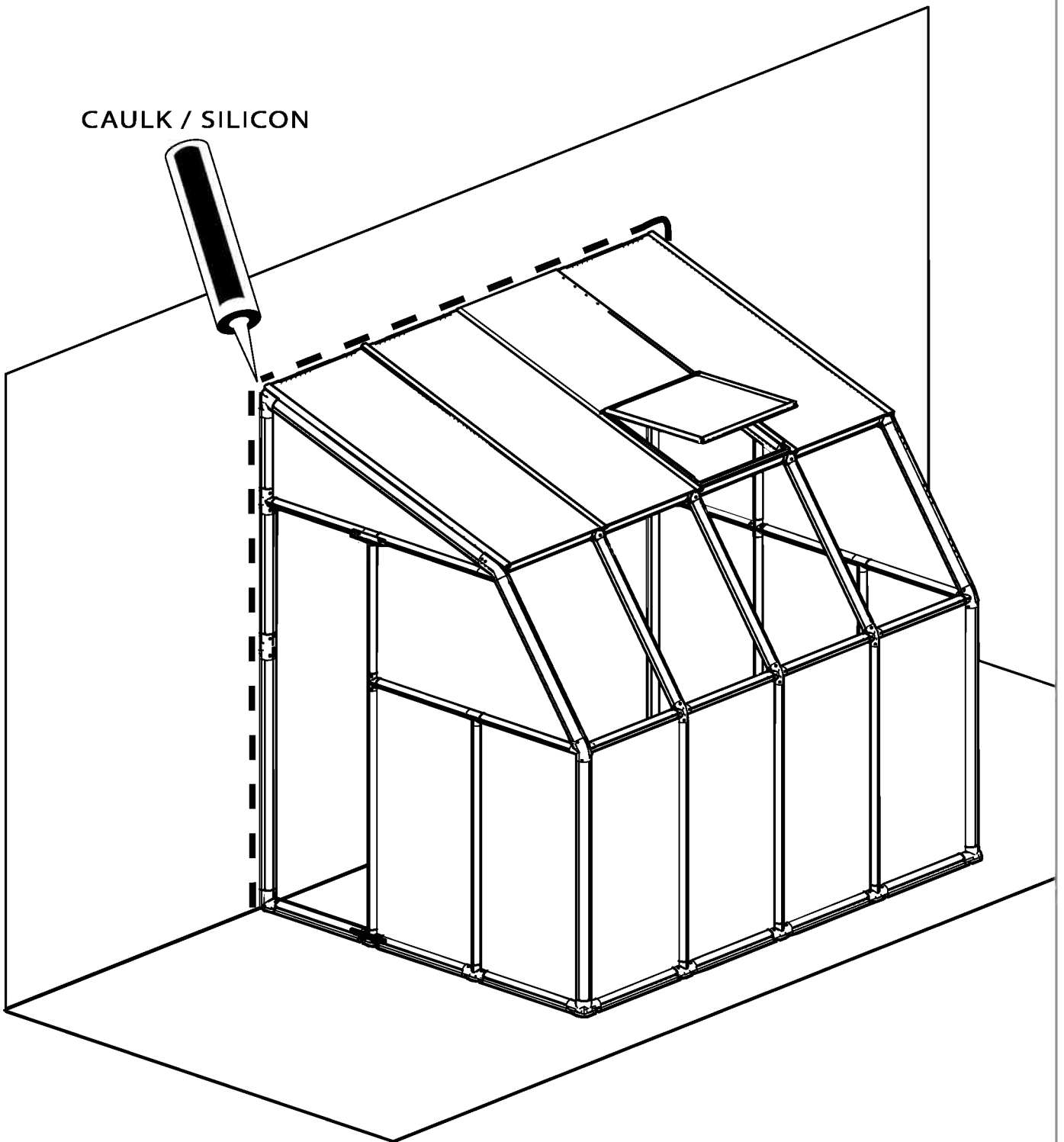

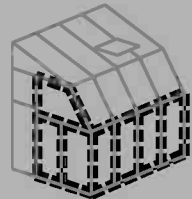

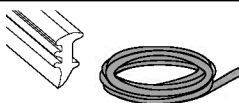
Item		Qty.
GF		

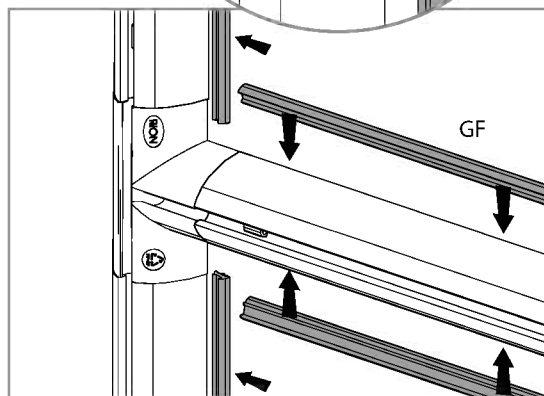
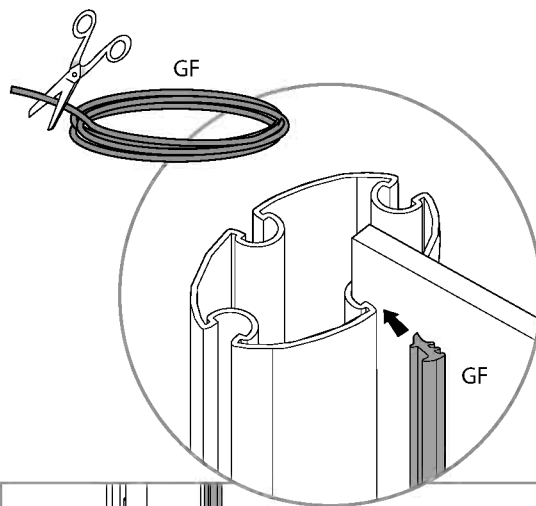
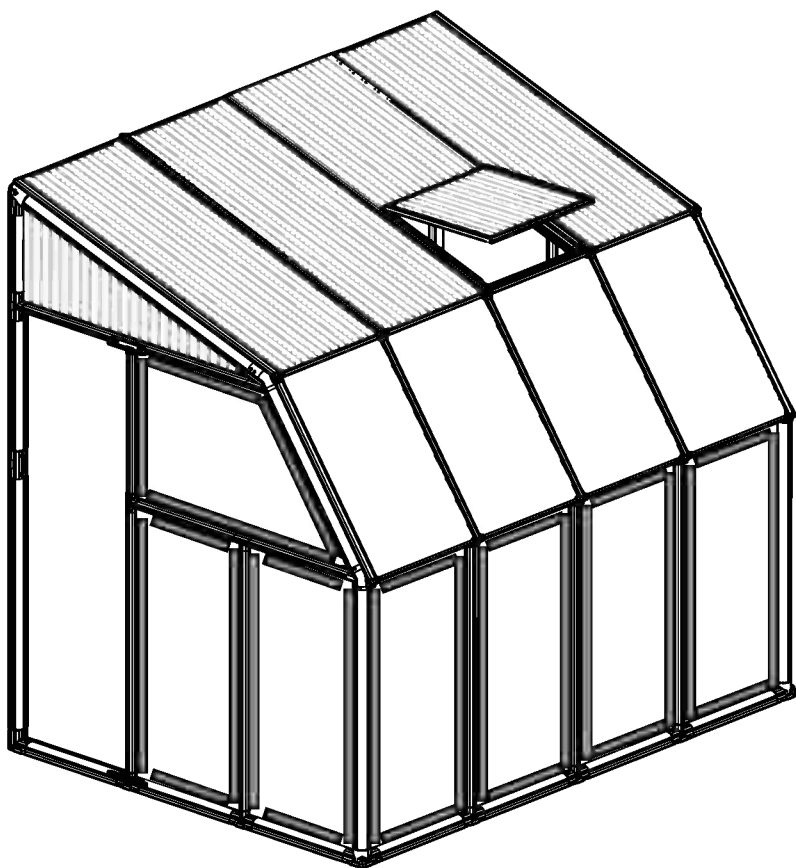
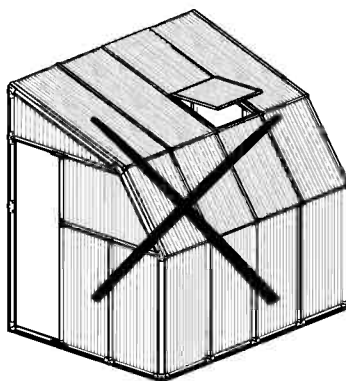
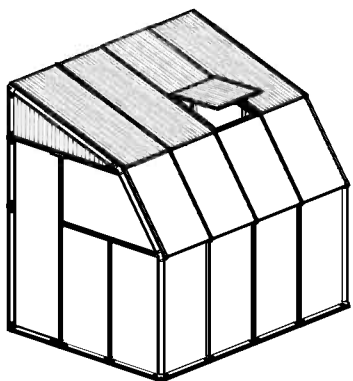

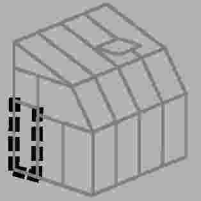

Item		Qty.
E1		2
E100		1
18		2
466		2
7224		2
7215 / 7216		1
pin1		4

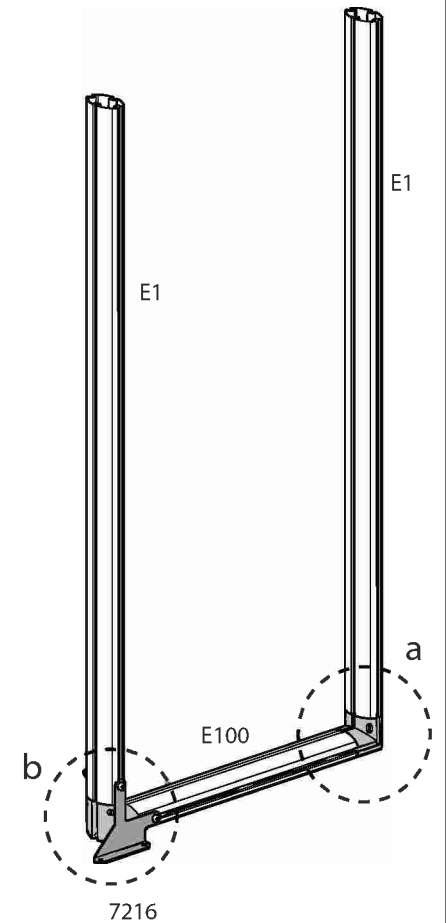
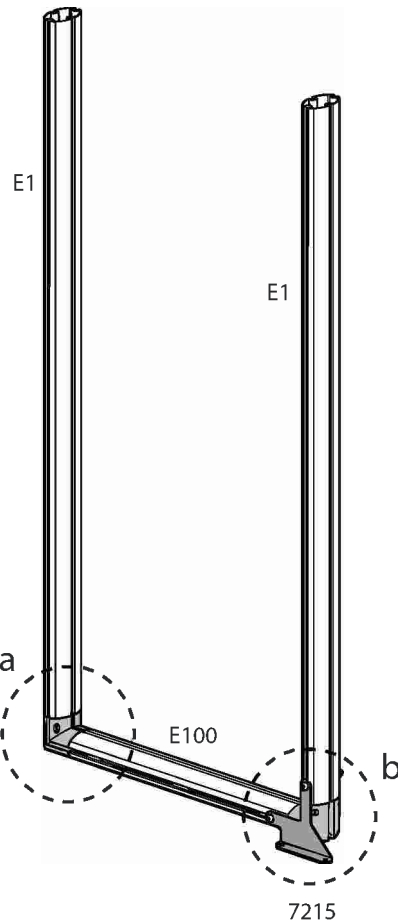
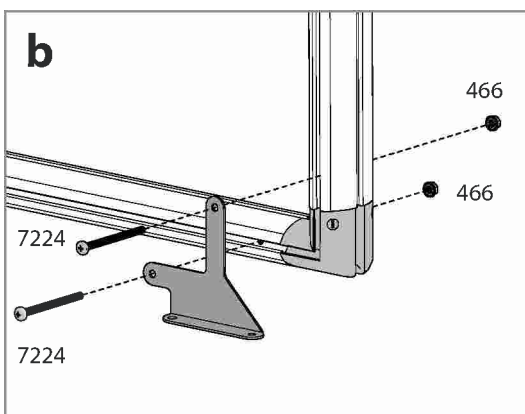
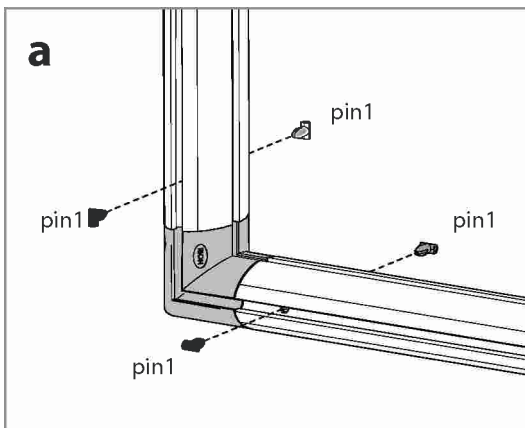
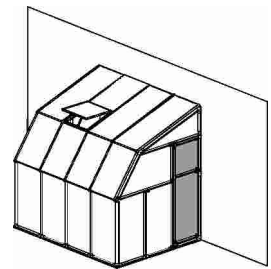
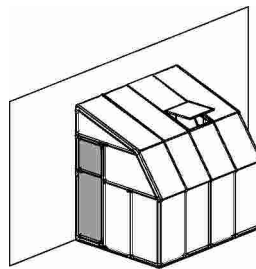
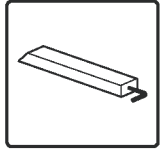
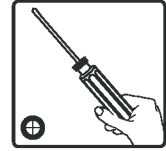

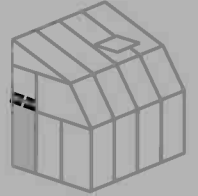

Item		Qty.
7544/ PN127		1
E100		2
09		1
DoorH33		1
pin1		8

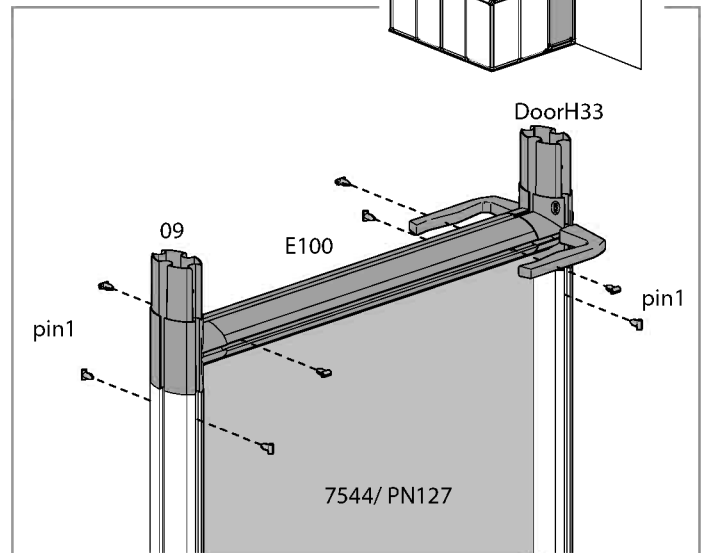
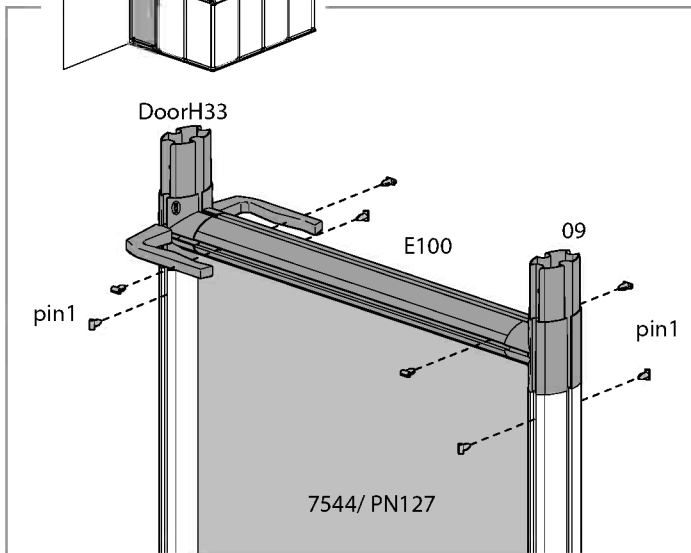
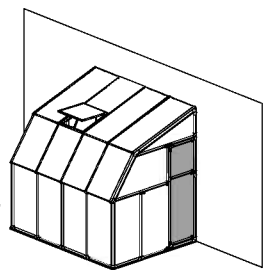
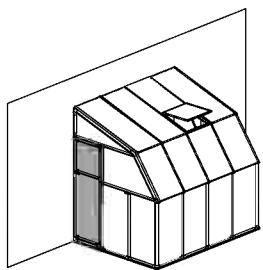
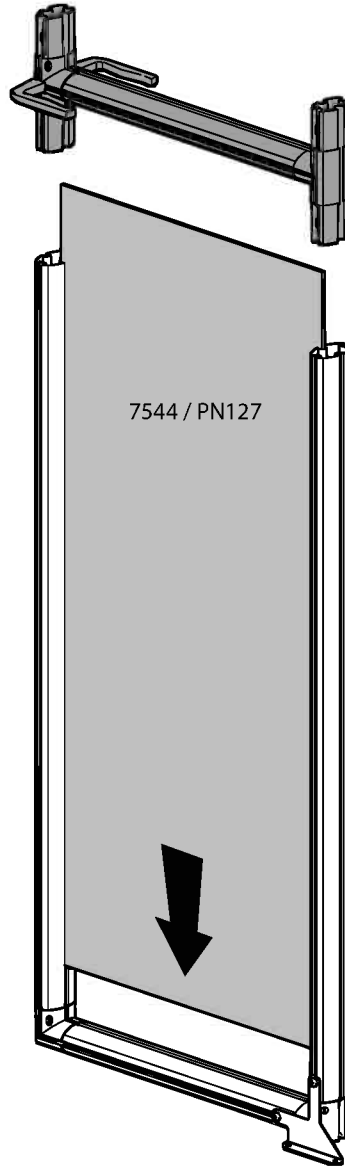

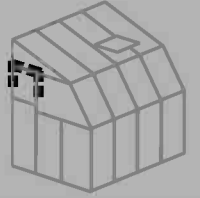

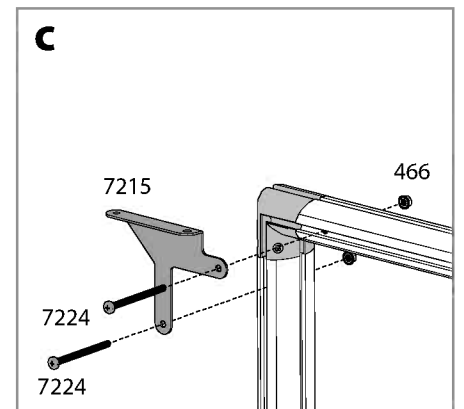
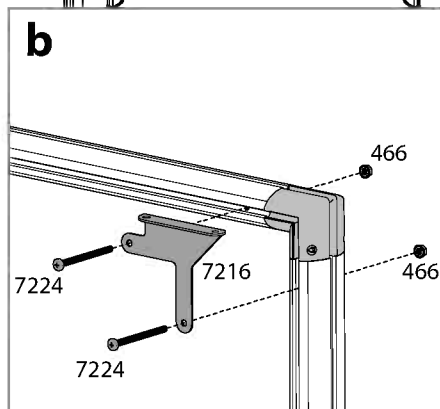
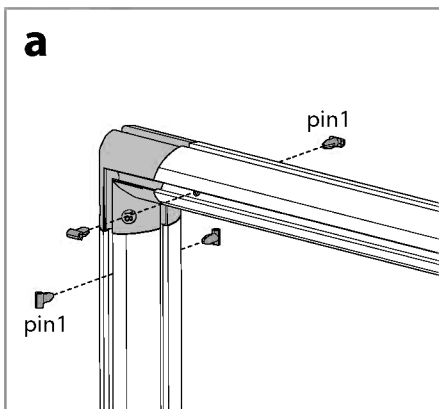
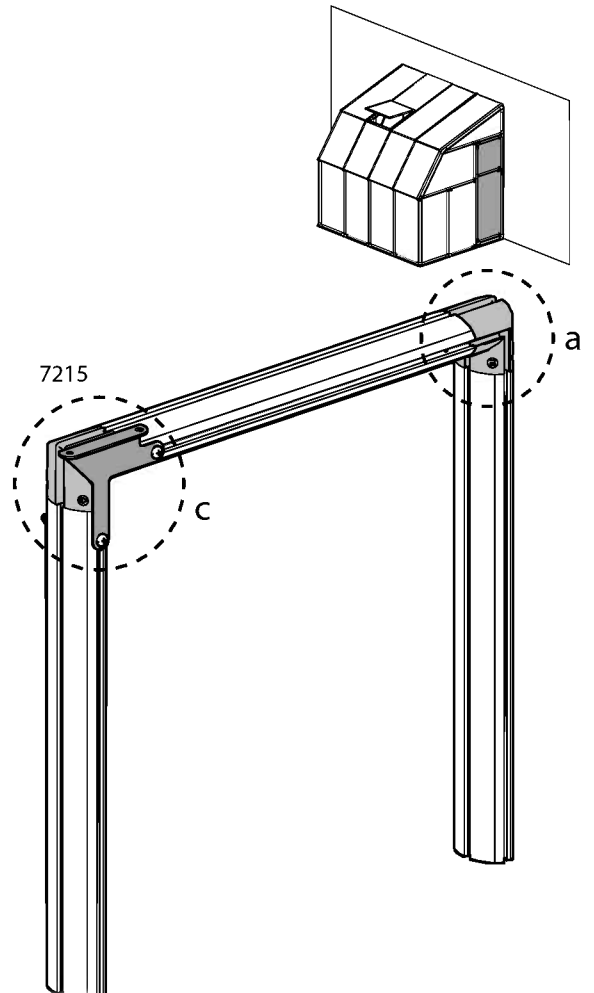
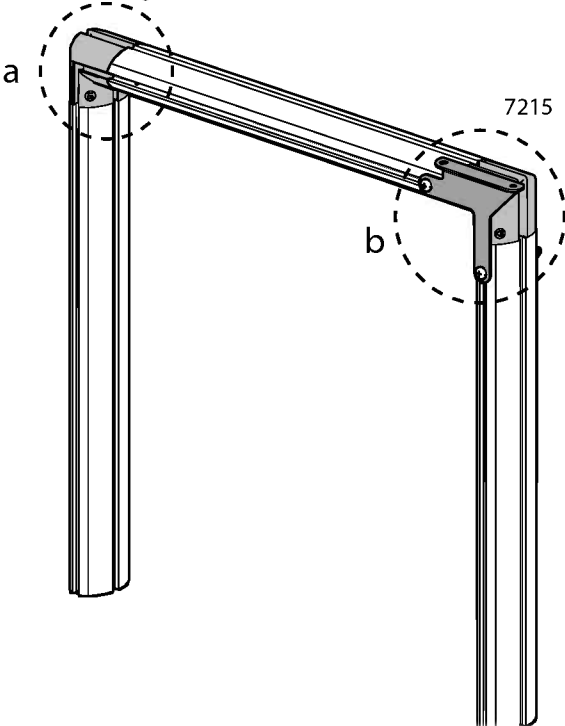
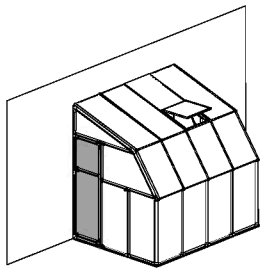
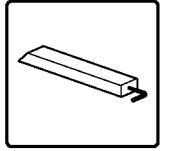
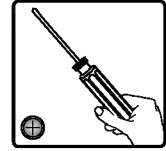

Item		Qty.
E102		2
E100		1
18		2
466		2

Item		Qty.
7224		2
7215 / 7216		1
pin1		4



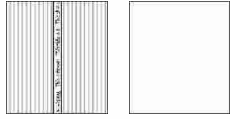

Item		Qty.
7616/ PN128		1
pin1		4

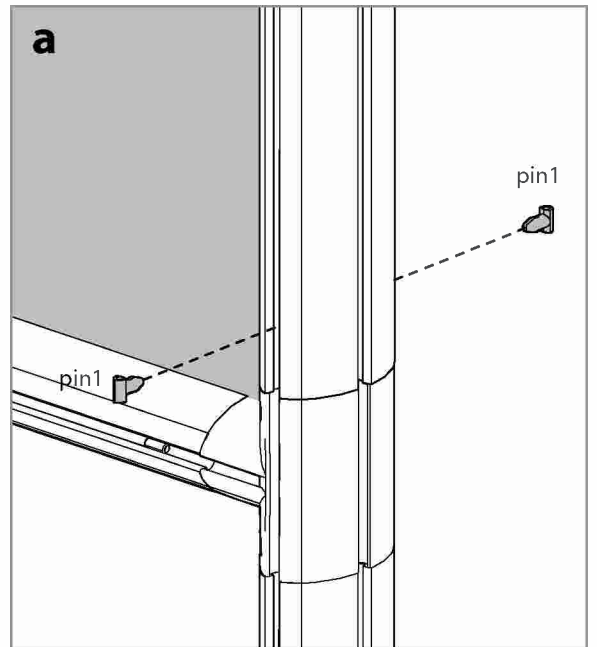
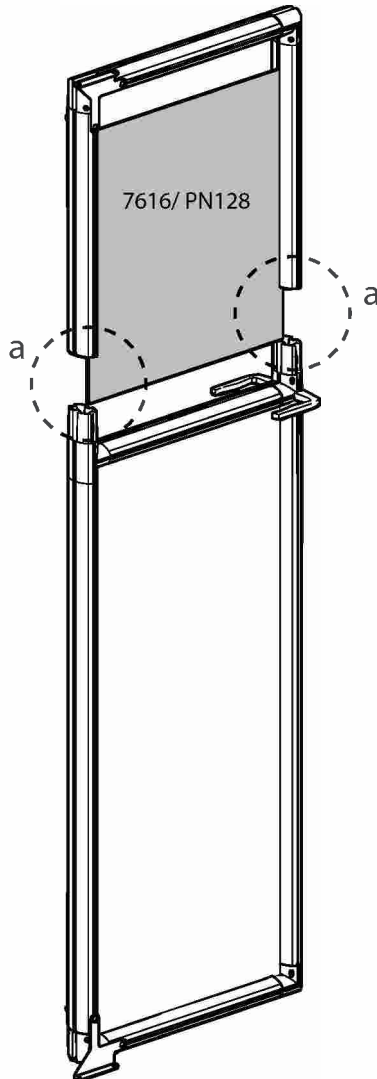
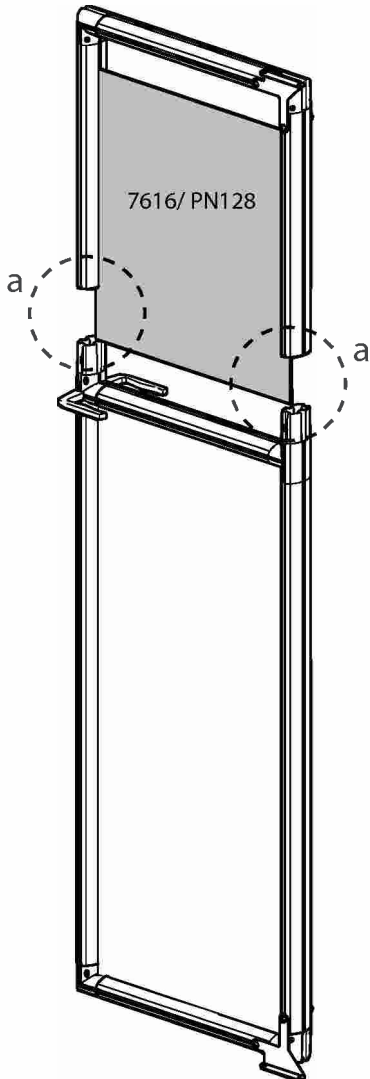
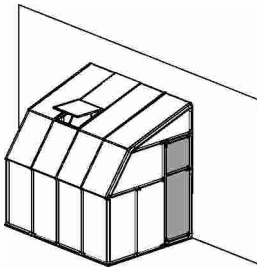
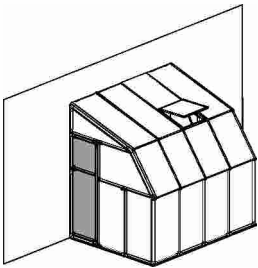
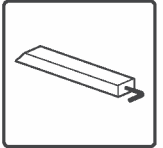

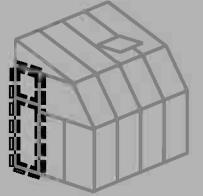

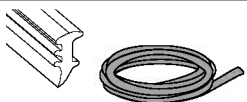
Item		Qty.
GF		

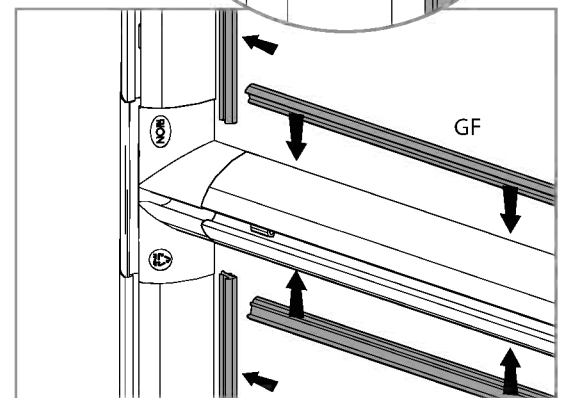
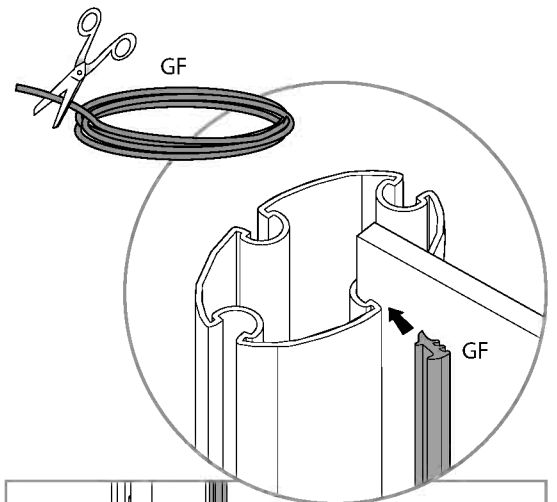
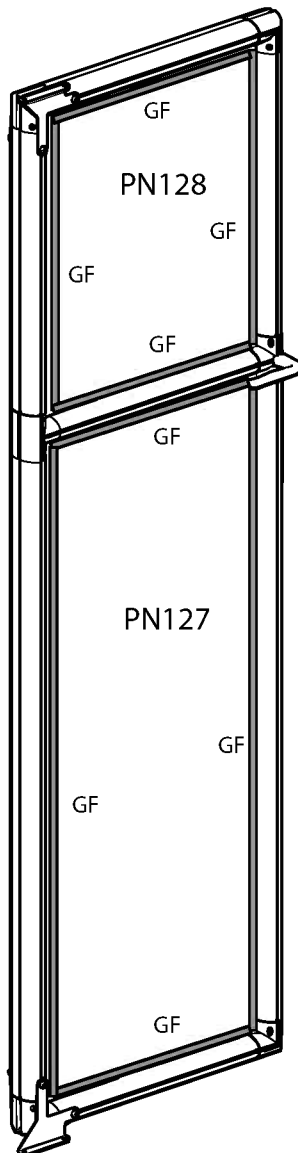
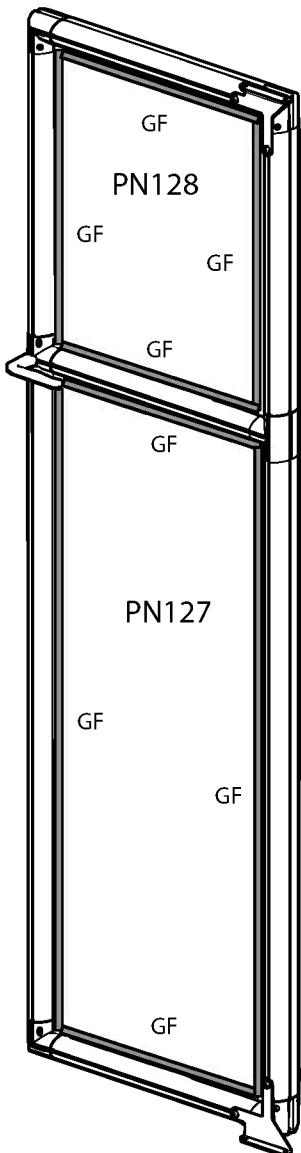
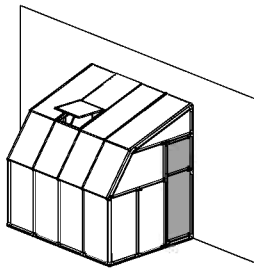
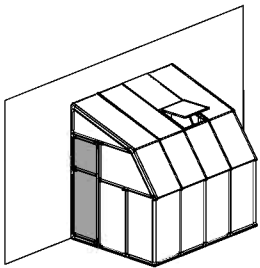
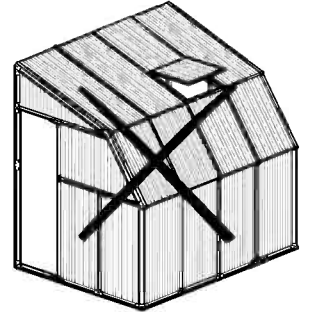
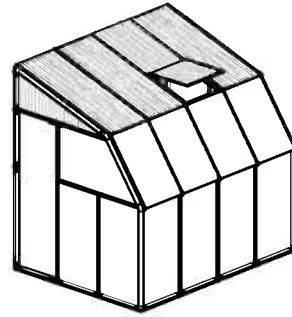
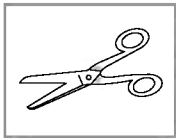

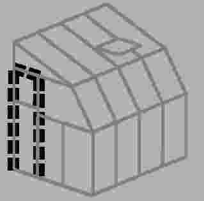

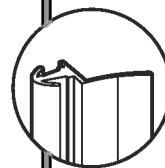
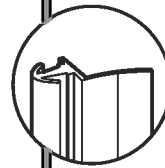
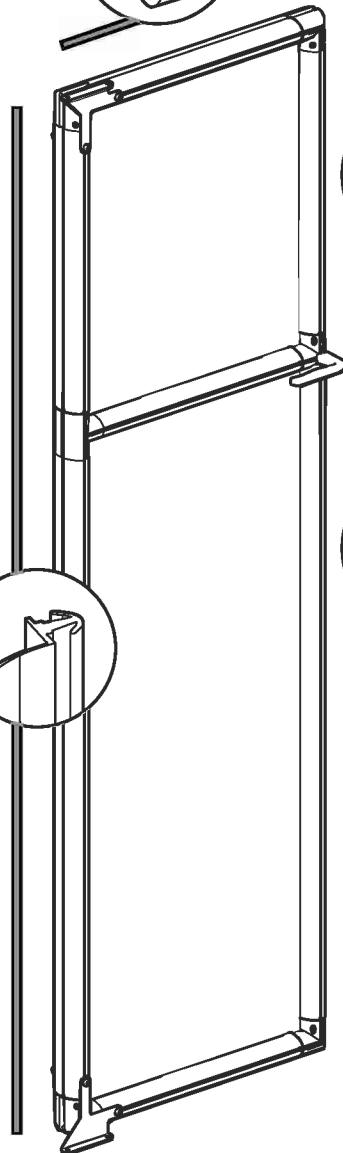
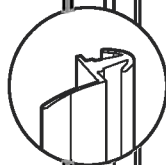
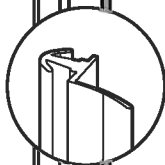
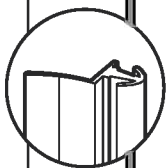
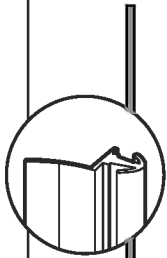
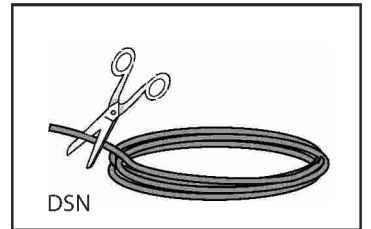
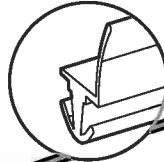
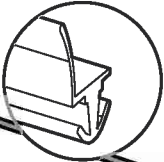
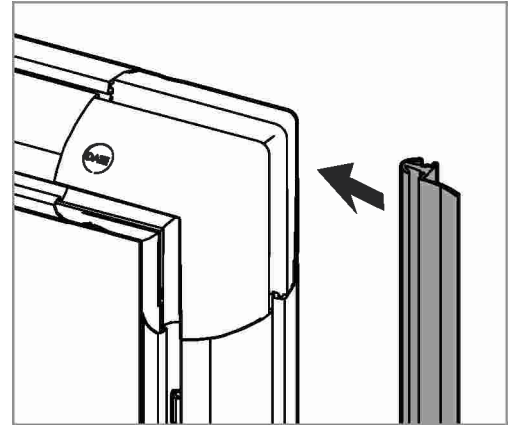
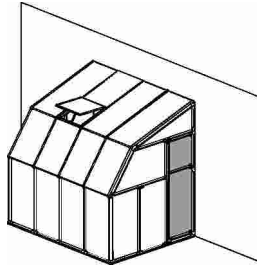
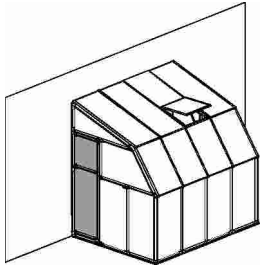

Item		Qty.
DSN		1

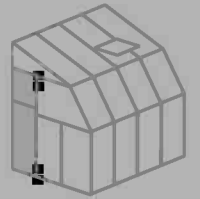



Item		Qty.
4016		2
7279		2
425		2

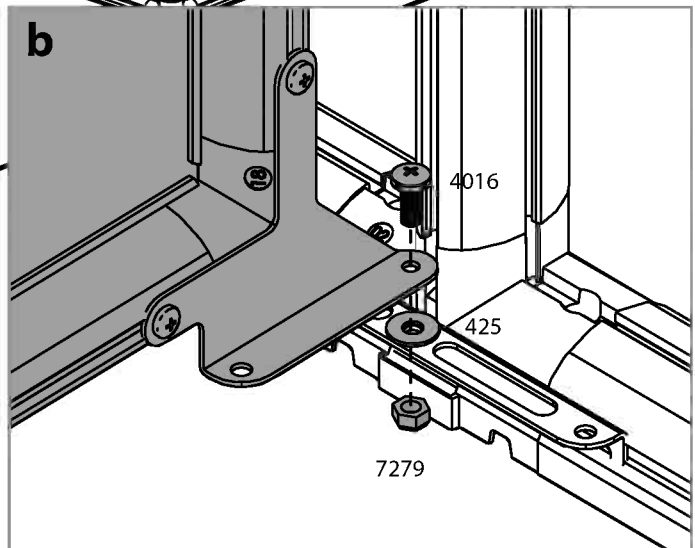
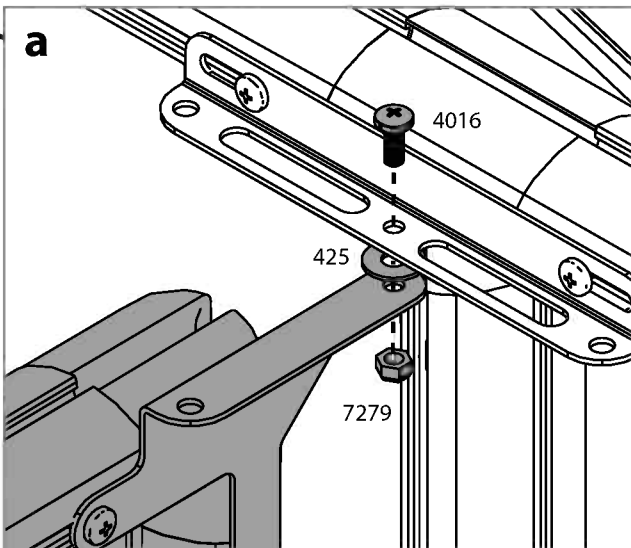
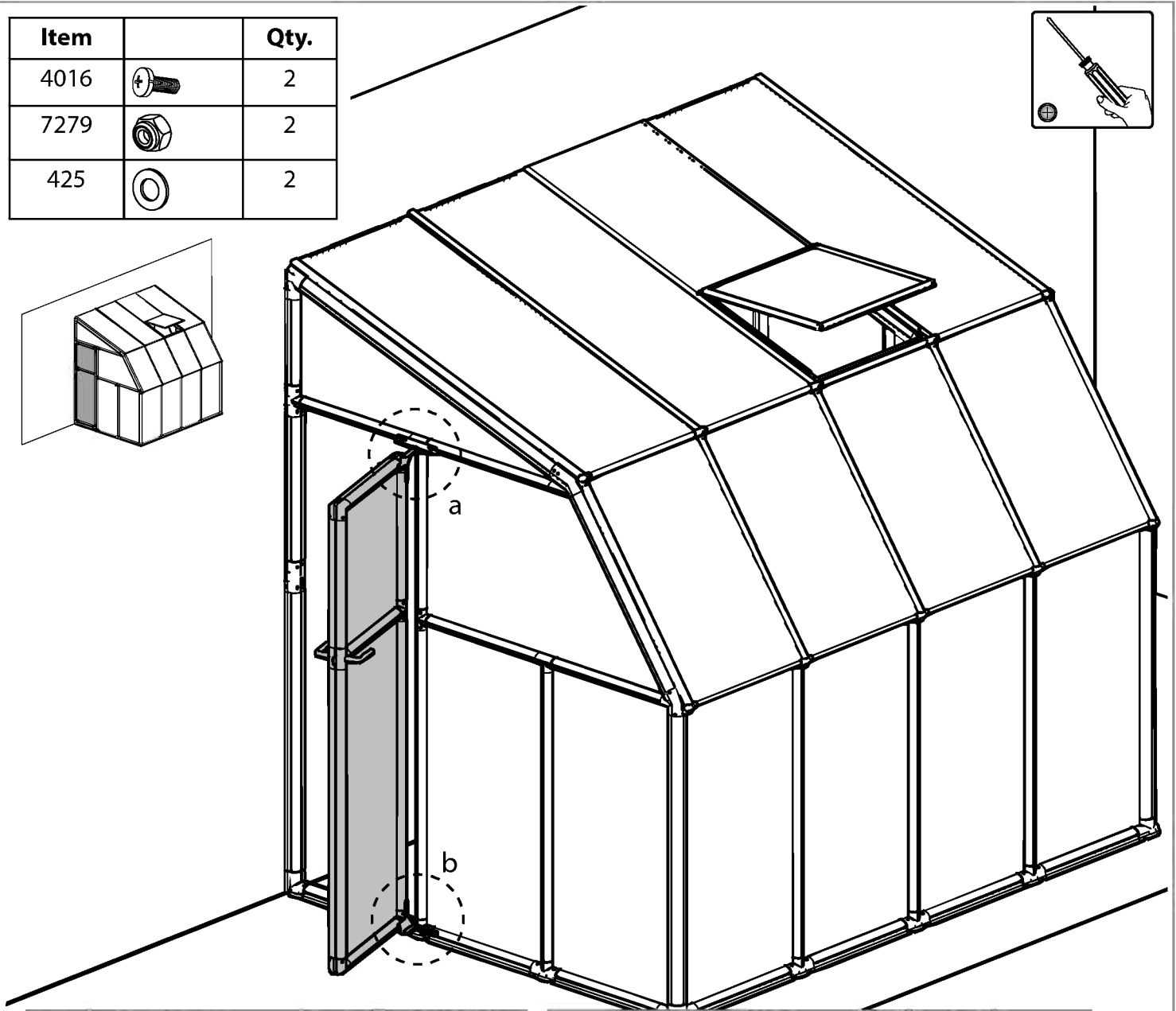
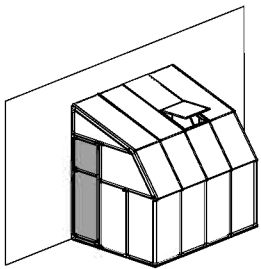
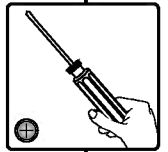

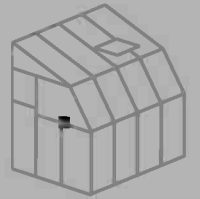

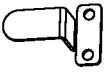
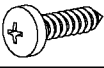
Item		Qty.
7273		1
7281		2

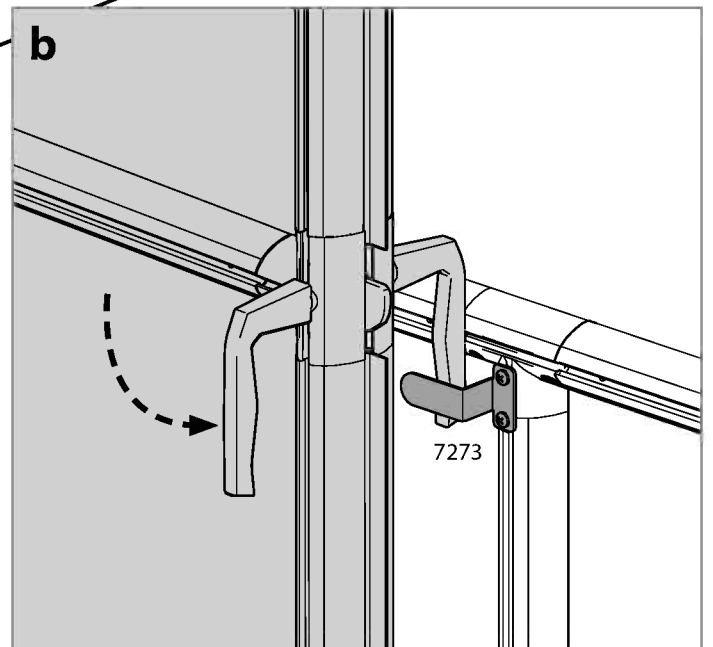
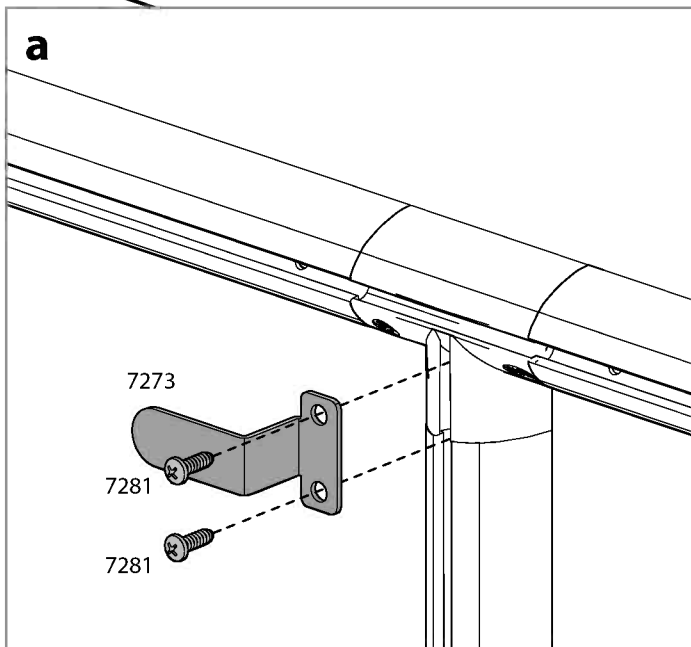
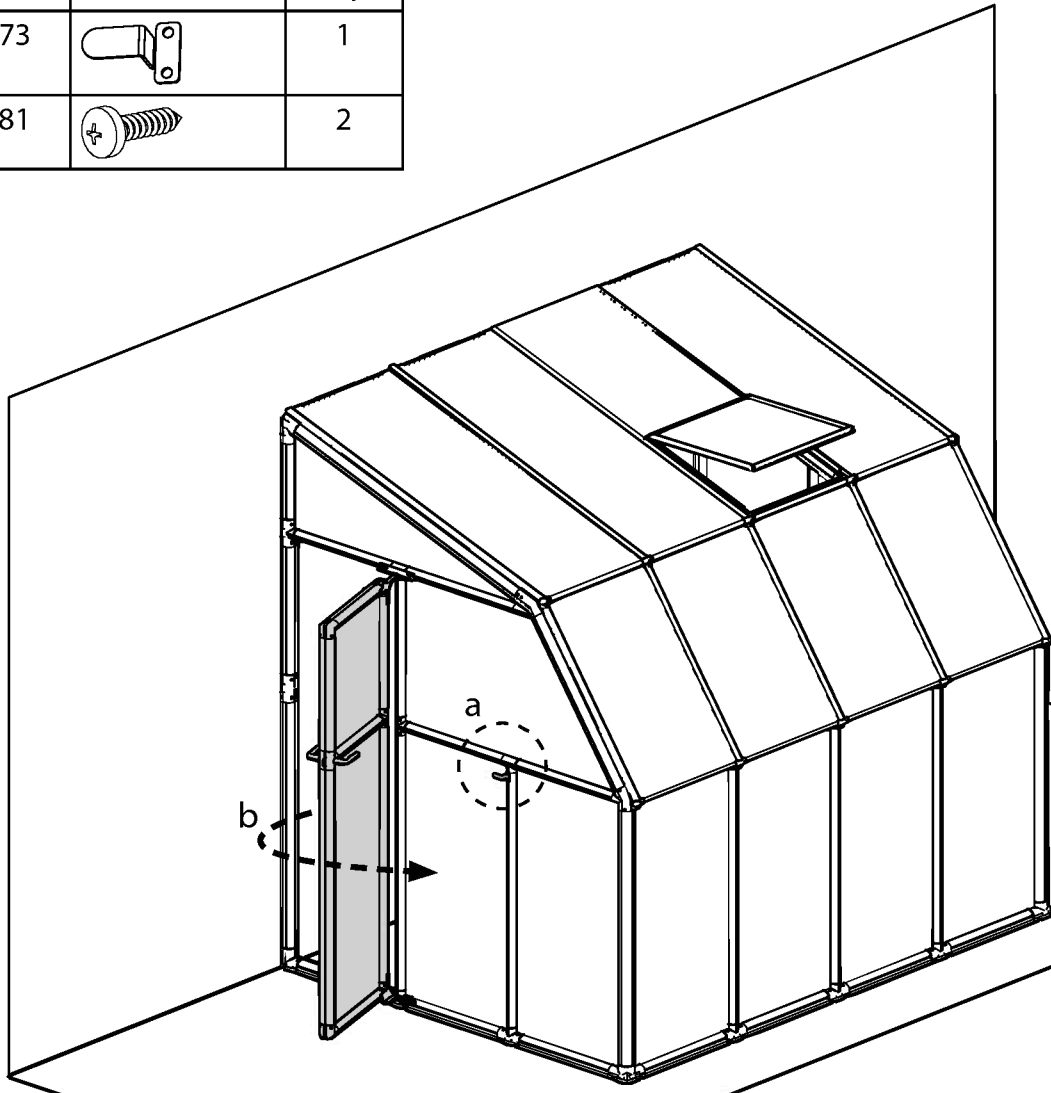
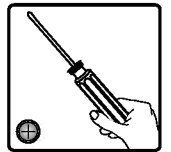

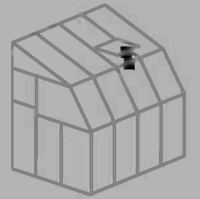

Item		Qty.
99		1
22		1
7441		1
7220		1
466		2

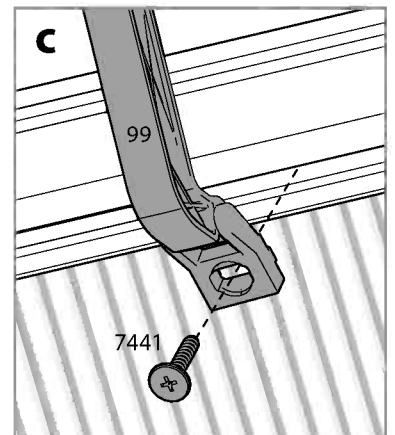
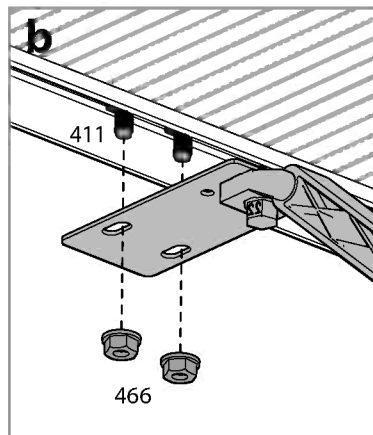
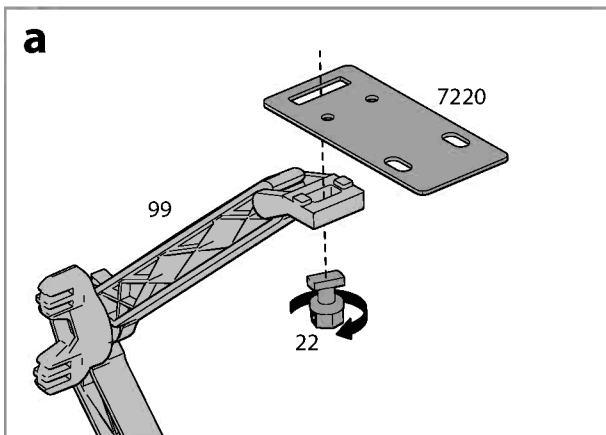
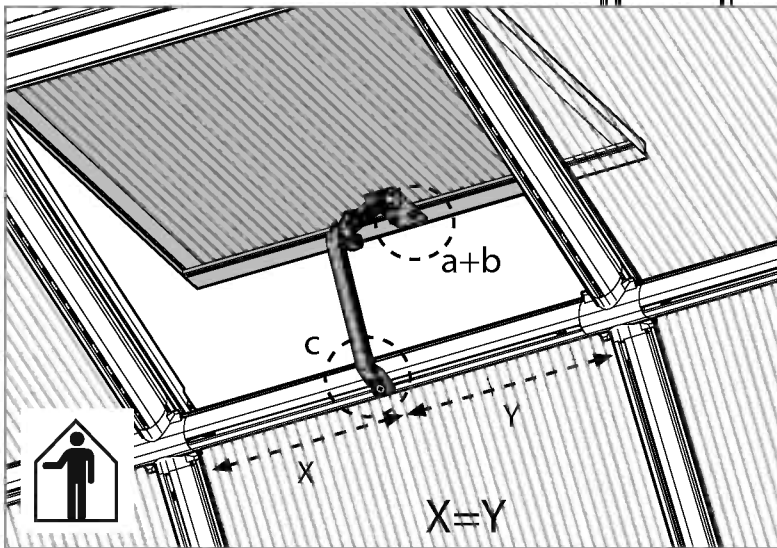
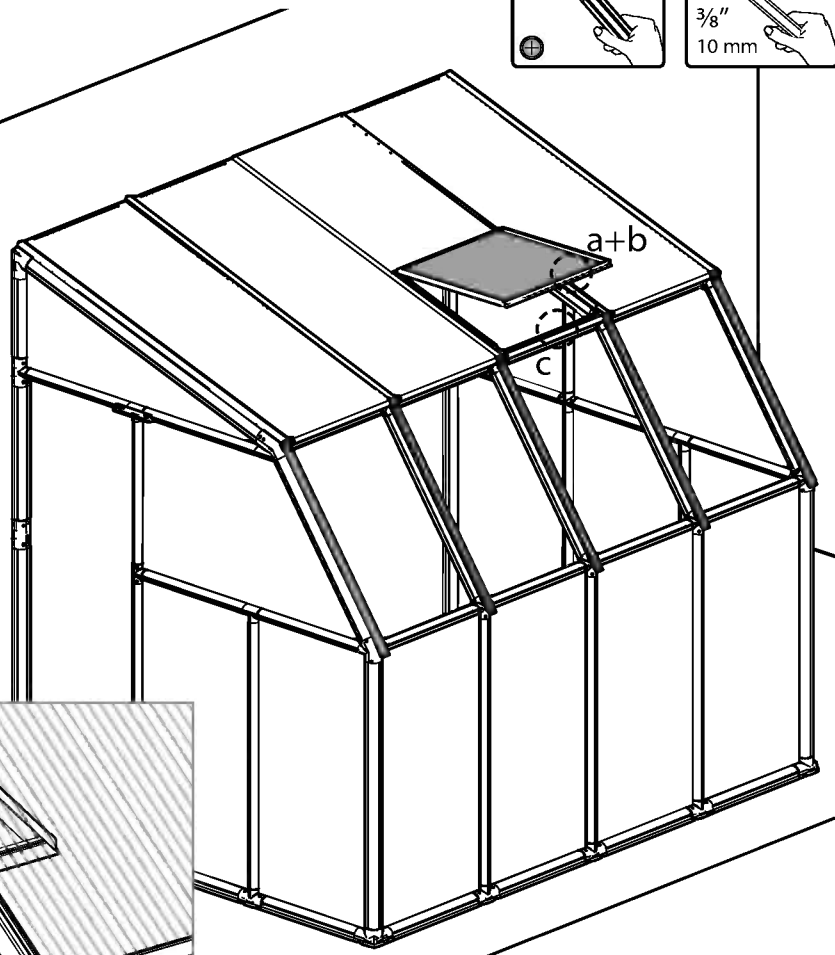
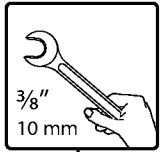
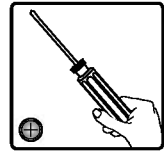

## Palram's 7 years Limited Warranty

### Product Details: Garden shelters and patio covers

Palram Applications (1995) Ltd (Company number: 512106824) whose registered office is at Teradion Industrial Park, M.P Misgav 20174, Israel ("Palram") warrants that the Product will be free from defects in material or workmanship for a period of Seven years from the original date of purchase subject to the definitions, terms and conditions contained in this warranty.

#### 1. Conditions

- 1.1 This warranty shall be valid only if the Product is installed, cleaned, handled and maintained in accordance with Palram's written recommendations.
- 1.2 Without derogating from the above, damage caused by use of force, incorrect handling, inappropriate use, neglectful use or assembly or maintenance, accidents, impact from foreign objects, vandalism, pollutants, alteration, painting, connecting, gluing, sealing not in accordance with the user's manual, or damage resulting from cleaning with incompatible detergents and minor deviations of the Product are not covered by this warranty.
- 1.3 This warranty does not apply to damage resulting from 'force majeure', which includes but is not limited to, hail, storm, tornado, hurricane, blizzard, flood, fire effects.
- 1.4 This warranty is void if structural parts and components used are not compatible with Palram's written recommendations.
- 1.5 This Warranty applies only to the original purchaser of the Product. It does not extend to any other purchaser or user of the Product (including, but not limited to, any person who acquires the Product from the original purchaser).

#### 2. Claims and Notifications

- 2.1 Every warranty claim must be notified in writing to Palram within 30 days after the discovery of the defective Product, enclosing the original sales receipt and this warranty.
- 2.2 The claimant must allow Palram to inspect the Product involved and the installation site itself while the Product is still in its original position and has not been removed or moved or altered in any way and/or return the Product to Palram for testing.
- 2.3 Palram reserves the right to investigate independently the cause of any failure.

#### 3. Compensation

- 3.1 If a claim under this Warranty is properly notified and approved by Palram, the purchaser, at Palram's option, may either (a) purchase a replacement Product or part/s; or (b) receive refund of the original Product or part/s purchase price, all in accordance with the following schedule:

Period After Purchasing	Replacement Product or Part/s	Refund
From date of purchase up to end of 1 <sup>st</sup> year	Free of charge	100%
End of 1 <sup>st</sup> Year up to end of 2 <sup>nd</sup> year	purchaser will pay 15% of the original purchase price	85%
End of 2 <sup>nd</sup> year up to end of 3 <sup>rd</sup> year	purchaser will pay 30% of the original purchase price	70%
End of 3 <sup>rd</sup> year up to end of 4 <sup>th</sup> year	purchaser will pay 45% of the original purchase price	55%
End of 4 <sup>th</sup> year up to end of 5 <sup>th</sup> year	purchaser will pay 60% of the original purchase price	40%
End of 5 <sup>th</sup> year up to end of 6 <sup>th</sup> year	purchaser will pay 75% of the original purchase price	25%
End of 6 <sup>th</sup> year up to end of 7 <sup>th</sup> year	purchaser will pay 85% of the original purchase price	15%

- 3.2 For avoidance of any doubt, calculation for determination regarding compensation for defective part/s, according to the schedule above, will be based on the contribution of the defective part to the original cost of the Product. Palram reserves the right to provide substitutions if the Product or any part of it is unavailable or obsolete.
- 3.3 This warranty does not cover any costs and expenses of removal and installation of the Product or taxes or shipping cost or any other direct or indirect loss(es) which may result from the Product failure.

#### 4. General Conditions and Limitations

- 4.1 OTHER THAN HAS BEEN SPECIFICALLY STATED IN THIS WARRANTY, ALL OTHER WARRANTIES, WHETHER EXPRESS OR IMPLIED, INCLUDING ALL IMPLIED WARRANTIES OF MERCHANTABILITY OR FITNESS FOR A PARTICULAR PURPOSE ARE EXCLUDED SO FAR AS THE LAW PERMITS.
- 4.2 EXCEPT WHERE WE HAVE SPECIFICALLY STATED IN THIS WARRANTY, PALRAM SHALL NOT BE LIABLE FOR ANY LOSSES OR DAMAGES THE PURCHASER SUFFERS DIRECTLY, INDIRECTLY, OR AS A CONSEQUENCE OF USING, OR IN ANY OTHER WAY CONNECTED TO THE PRODUCT.
- 4.3 IF PALRAM IS PROHIBITED UNDER ANY APPLICABLE LAW FROM EXCLUDING THE IMPLIED WARRANTIES OF MERCHANTABILITY OR FITNESS FOR A PARTICULAR PURPOSE IN RELATION TO THE PRODUCT, THE DURATION OF ALL SUCH IMPLIED WARRANTIES IS EXPRESSLY LIMITED TO THE DURATION OF THIS WARRANTY OR, IF LONGER, THE MAXIMUM PERIOD REQUIRED BY APPLICABLE LAW.
- 4.4 THE PURCHASER IS SOLELY RESPONSIBLE FOR DETERMINING WHETHER THE HANDLING, STORAGE, ASSEMBLY, INSTALLATION OR USE OF THE PRODUCT IS SAFE AND APPROPRIATE IN ANY LOCATION, FOR ANY GIVEN APPLICATION OR IN ANY GIVEN CIRCUMSTANCE. PALRAM IS NOT RESPONSIBLE FOR ANY DAMAGES OR INJURY TO THE PURCHASER, ANY OTHER PERSON OR ANY PROPERTY RESULTING FROM THE IMPROPER HANDLING, STORAGE, INSTALLATION, ASSEMBLY OR USE OF THE PRODUCT OR THE FAILURE TO FOLLOW THE WRITTEN INSTRUCTIONS REGARDING THE HANDLING, STORAGE, INSTALLATION, ASSEMBLY AND USE OF THE PRODUCT.
- 4.5 UNLESS OTHERWISE EXPRESSLY INDICATED BY PALRAM, THE PRODUCT IS INTENDED FOR NORMAL RESIDENTIAL USE ONLY. PALRAM IS NOT RESPONSIBLE FOR ANY LOSS, DAMAGE, COST OR EXPENSE RESULTING FROM ANY USE OF THE PRODUCT FOR ANY PURPOSE THAT IS NOT RECOMMENDED BY THE WRITTEN INSTRUCTIONS OR THAT IS NOT PERMITTED BY ANY APPLICABLE LEGISLATION OR OTHER CODES IN EFFECT IN THE LOCATION WHERE THE PURCHASER WILL USE THE PRODUCT.

EN

## 7 Jahre beschränkte Garantie von Palram

### Angaben zum Produkt: Garten Überdachungen und Terrassendächer

Palram Applications (1995) Ltd (Firmennummer: 512106824) mit Sitz in Teradion Industrial Park, M.P Misgav 20174, Israel („Palram“) garantiert, dass das Produkt für einen Zeitraum von Sieben Jahren ab dem Kaufdatum frei von Mängeln in Material und Verarbeitung wird, und den Definitionen, Begriffen und Bedingungen die in dieser Garantie enthalten sind unterliegt.

#### 1. Bedingungen

- 1.1 Diese Garantie ist nur gültig, wenn das Produkt in Übereinstimmung mit den schriftlichen Empfehlungen von Palram installiert, gereinigt, behandelt und gepflegt ist.
- 1.2 Ohne Abweichung von oben genannten, Schäden, die durch Anwendung von Gewalt, unsachgemäße Behandlung, unsachgemäße Verwendung, nachlässige Nutzung, Montage oder Wartung, Unfälle, Auswirkungen von Fremdkörpern, Vandalismus, Verschmutzung, Veränderung, Malerei, Verbinden, Kleben und Dichten, nicht in Übereinstimmung mit der Bedienungsanleitung, verursacht werden, oder Schäden, die bei Reinigung mit inkompatiblen Reinigungsmitteln entstehen, so wie geringfügige Abweichungen des Produkts, werden durch diese Garantie nicht abgedeckt.
- 1.3 Diese Garantie gilt nicht für Schäden, die durch 'höhere Gewalt' verursacht werden (beinhaltend aber nicht beschränkt auf: Hagel, Sturm, Tornado, Hurrikan, Schneesturm, Überschwemmungen, Feuer Auswirkungen).
- 1.4 Diese Garantie erlischt, falls Bauteile und Komponente, die nicht mit den schriftlichen Empfehlungen von Palram kompatibel sind, verwendet werden.
- 1.5 Diese Garantie gilt ausschließlich für den ursprünglichen Käufer des Produkts. Sie erweitert sich nicht auf keine anderen Käufer oder Benutzer des Produkts (einschließlich, aber nicht beschränkt auf irgendeine andere Person die das Produkt von den ursprünglichen Käufer erwirbt).

#### 2. Ansprüche und Mitteilungen

- 2.1 Jeder Gewährleistungsanspruch muss Palram innerhalb von 30 Tagen nach Entdeckung des fehlerhaften Produkts schriftlich vorgelegt werden. Hierzu reichen Sie bitte auch den Original-Kaufbeleg und diese Garantie mit ein.
- 2.2 Der Antragsteller muss Palram erlauben den betroffenen Produkt und den Aufstellungsort selbst zu überprüfen, während das Produkt noch in seiner ursprünglichen Position ist und nicht entfernt oder verschoben oder in irgendeiner Weise verändert wurde, und/oder den Produkt an Palram zum Testen zu senden.
- 2.3 Palram behält sich das Recht vor die Fehlerursachen unabhängig zu untersuchen.

#### 3. Entschädigung

- 3.1 Ist ein Anspruch gemäß dieser Garantie ordnungsgemäß angemeldet und bei Palram genehmigt worden, kann der Käufer, nach eigenem Ermessen von Palram, entweder (a) ein Ersatzprodukt oder Teil/e erwerben; oder (b) eine Erstattung des ursprünglichen Produkt oder Teil/e Kaufpreises erhalten, alles in Übereinstimmung mit dem folgendem Schema:

Zeitraum nach Erwerbung	Ersatzprodukt bzw. Ersatzteil/e	Rückerstattung
Ab Kaufdatum bis zum Ende des 1. Jahr	Kostenlos	100%
Ende des 1. Jahr bis zum Ende des 2. Jahr	Käufer zahlt 15% des ursprünglichen Kaufpreises	85%
Ende des 2. Jahr bis zum Ende des 3. Jahr	Käufer zahlt 30% des ursprünglichen Kaufpreises	70%
Ende des 3. Jahr bis zum Ende des 4. Jahr	Käufer zahlt 45% des ursprünglichen Kaufpreises	55%
Ende des 4. Jahr bis zum Ende des 5. Jahr	Käufer zahlt 60% des ursprünglichen Kaufpreises	40%
Ende des 5. Jahr bis zum Ende des 6. Jahr	Käufer zahlt 75% des ursprünglichen Kaufpreises	25%
Ende des 6. Jahr bis zum Ende des 7. Jahr	Käufer zahlt 85% des ursprünglichen Kaufpreises	15%

- 3.2 Um jegliche Zweifel auszuschließen, wird sich die Berechnung für die Bestimmung über Entschädigungen für defekte Teil/e, entsprechend der obigen Schema, auf dem Beitrag des defekten Teils an den ursprünglichen Kosten des Produktes beruhen. Palram behält sich das Recht vor für ein Ersatz zu sorgen, falls der Produkt oder ein Teil davon nicht verfügbar oder veraltet ist.
- 3.3 Diese Garantie erstreckt sich nicht auf Kosten und Ausgaben für Aus- und Einbau des Produkts oder Steuern oder Versandkosten oder sonstige direkte oder indirekte Verlust/e die sich von einem Produktfehler ergeben können.

#### 4. Allgemeine Bedingungen und Einschränkungen

- 4.1 ANDERS ALS BESONDERS IN DIESER GARANTIE ANGEGBEN, ALLE ANDEREN GARANTIE, OB AUSDRÜCKLICH ODER IMPLIZIT, EINSCHLIESSLICH ALLER EINGESCHLOSSENEN GARANTIELEISTUNGEN DER MARKTGÄNGIGKEIT ODER EIGNUNG FÜR EINEN BESTIMMTEN ZWECK SIND SO WEIT DIES RECHTLICH MÖGLICH IST AUSGESCHLOSSEN.
- 4.2 AUSSER ALS AUSDRÜCKLICH IN DIESER GARANTIE ANGEGBEN, HAFET PALRAM NICHT FÜR IRGENDWELCHE VERLUSTE ODER SCHÄDEN DIE DER KÄUFER, DIREKT ODER INDIREKT ODER ALS FOLGE DER NUTZUNG ODER IN IRGENDWELCHEN ANDEREN MIT DEM PRODUKT VERBUNDENEN WEISE LEIDET.
- 4.3 FALLS PALRAM EIN AUSSCHLUSS DER STILLSCHWEIGENDEN GARANTIE DER MARKTGÄNGIGKEIT ODER EIGNUNG FÜR EINEN BESTIMMTEN ZWECK IN BEZUG AUF DAS PRODUKT NACH GELTENDEM RECHT NICHT GESTATTET IST, WIRD DIE DAUER ALLER SOLCHEN GARANTIE AN AUSDRÜCKLICH AUF DIE DAUER DIESER GARANTIE BESCHRÄNK, ODER FALLS LÄNGER, AUF DIE GESETZLICH VORGESCHRIEBENE HÖCHSTDAUER.
- 4.4 DER KÄUFER IST ALLEIN DAFÜR VERANTWORTLICH FESTZUSTELLEN, OB DIE HANDHABUNG, LAGERUNG, MONTAGE, INSTALLATION ODER VERWENDUNG DES PRODUKTS AN BELIEBIGEN STANDORT UND FÜR JEDE GEGEBENE ANWENDUNG ODER SITUATION, SICHER UND ANGEMESSEN IST. PALRAM IST NICHT VERANTWORTLICH FÜR SCHÄDEN ODER VERLETZUNGEN DES KÄUFERS, ANDERER PERSONEN ODER DES EIGENTUMS, DIE IN FOLGE EINER UNSACHGEMÄSSEN HANDHABUNG, LAGERUNG, EINBAU, MONTAGE ODER NUTZUNG DES PRODUKTS ODER DURCH NICHTBEACHTUNG DER ANWEISUNGEN ZUR HANDHABUNG, LAGERUNG, EINBAU, MONTAGE UND NUTZUNG DES PRODUKTES ENTSTANDEN SIND.
- 4.5 SOWEIT NICHT AUSDRÜCKLICH ANDERS BY PALRAM ANGEGBEN, IST DAS PRODUKT FÜR NORMALE WOHNUNGEN BESTIMMT. PALRAM HAFET NICHT FÜR VERLUSTE, SCHÄDEN, KOSTEN ODER AUSGABEN, DIE AUS EINER NICHT VON DEN ANWEISUNGEN EMPFOHLENE VERWENDUNG DES PRODUKTS ZU IRGENDNEM ZWECK ENTSTEHEN ODER DIE VON KEINEM GELTENDEM RECHTSVORSCHRIFTEN ODER ANDEREN CODES ERLAUBT SIND DIE AN DEM ORT WO DER KÄUFER DEN PRODUKT BENUTZEN WIRD IN KRAFT SIND.

DE

## Garantie limitée à 7 ans de Palram

### Détails du produit: Abris de Jardin et Couvres Patio

Palram Applications (1995) Ltd (Compagnie n° 512106824) dont le siège social est adressé au Parc Industriel Teradion, M.P. Misgav 20174, Israël ("Palram") garantit que le Produit n'a aucun défaut de matériel ou de manufacture pour une période de Sept ans à dater de la date d'acquisition, conformément aux définitions et conditions incluses dans cette garantie.

#### 1. Conditions

- 1.1 Cette garantie ne sera valide que si le Produit est installé, nettoyé, manipulé et entretenu conformément aux recommandations écrites de Palram.
- 1.2 Sans déroger de ce qui est susdit, tout dommage causé par usage de la force, une mauvaise manipulation, un usage inapproprié, une utilisation, un montage ou une maintenance négligente, des accidents, un impact avec d'autres objets étrangers, du vandalisme, des polluants, un dégât, une peinture, connexion, collage, scellage qui n'est pas conforme avec le manuel de l'utilisateur ou tout dommage résultant de son nettoyage avec un détergent incompatible et les moindres déviations du Produit ne sont pas couverts par cette garantie.
- 1.3 Cette garantie ne s'applique pas aux dommages résultant d'un acte de force majeure, qui comprend mais n'est pas limité par la grêle, la tempête, une tornade, un ouragan, un blizzard, une inondation ou les effets d'un incendie.
- 1.4 Cette garantie est nulle si des parties de la structure et des composants ne sont pas compatibles aux recommandations écrites par Palram.
- 1.5 Cette garantie ne s'applique qu'à l'acheteur d'origine du Produit. Elle ne s'étend pas à tout autre acquéreur ou utilisateur du Produit (y compris mais non limité à toute personne qui acquiert le Produit de son acquéreur d'origine).

#### 2. Réclamations et notifications

- 2.1 Toute demande de garantie doit être notifiée par écrit à Palram dans les 30 jours suite à la découverte du produit défectueux, accompagnée du ticket de caisse original et de cette garantie.
- 2.2 Le demandeur doit permettre à Palram d'inspecter le Produit impliqué et le site d'installation lorsque le Produit est dans son emplacement d'origine et n'a pas été enlevé ou déplacé ni modifié de quelque façon et/ou envoyer le Produit à Palram pour vérification.
- 2.3 Palram se réserve le droit d'enquêter indépendamment sur la cause de toute panne.

#### 3. Compensation

- 3.1 Si une réclamation sous cette Garantie est convenablement notifiée et approuvée par Palram, l'acheteur, au choix de Palram, peut soit (a) acquérir un Produit de remplacement ou des pièces; ou (b) recevoir un remboursement du prix d'achat du Produit d'origine ou d'une partie, tout cela conformément à la table suivante:

Période depuis l'achat	Produit de remplacement ou partie	Remboursement
Jusqu'à un an après l'achat	Gratuit	100%
De la fin de la 1 <sup>ère</sup> année à la fin de la 2 <sup>ème</sup>	L'acquéreur paiera 15% du prix d'achat d'origine	85%
De la fin de la 2 <sup>ème</sup> année à la fin de la 3 <sup>ème</sup>	L'acquéreur paiera 30% du prix d'achat d'origine	70%
De la fin de la 3 <sup>ème</sup> année à la fin de la 4 <sup>ème</sup>	L'acquéreur paiera 45% du prix d'achat d'origine	55%
De la fin de la 4 <sup>ème</sup> année à la fin de la 5 <sup>ème</sup>	L'acquéreur paiera 60% du prix d'achat d'origine	40%
De la fin de la 5 <sup>ème</sup> année à la fin de la 6 <sup>ème</sup>	L'acquéreur paiera 75% du prix d'achat d'origine	25%
De la fin de la 6 <sup>ème</sup> année à la fin de la 7 <sup>ème</sup>	L'acquéreur paiera 85% du prix d'achat d'origine	15%

- 3.2 Pour éviter le moindre doute, le calcul pour déterminer la compensation pour des pièces défectueuses, selon la table ci-dessus, sera basé sur la contribution de la pièce défectueuse au coût d'origine du Produit. Palram se réserve le droit de fournir des substitutions si si le Produit ou une partie de celui-ci n'est plus disponible ou est obsolète.
- 3.3 Cette garantie ne couvre pas les coûts et les dépenses de déplacement et d'installation du Produit ou les taxes et port ou toute autre perte directe ou indirecte qui pourrait résulter de la panne du Produit.

#### 4. Conditions générales et limitations

- 4.1 MIS À PART CE QUI A ÉTÉ SPÉCIFIQUEMENT INDIQUÉ DANS CETTE GARANTIE, TOUTES LES AUTRES GARANTIES, EXPRESSES OU SOUS-ENTENDUES, Y COMPRIS TOUTES LES GARANTIES SOUS-ENTENDUES DE VALEUR MARCHANDE OU D'ADAPTABILITÉ POUR UN OBJECTIF PARTICULIER SONT EXCLUES POUR AUTANT QUE LA LOI LE PERMET.
- 4.2 MIS À PART LA OU NOUS L'AVONS SPÉCIFIQUEMENT DÉCLARÉ DANS CETTE GARANTIE, PALRAM N'EST PAS RESPONSABLE DE TOUTE PERTE OU DOMMAGE DONT L'ACQUÉREUR SOUFFRIRAIT, DIRECTEMENT, INDIRECTEMENT OU EN CONSÉQUENCE DE L'UTILISATION DU PRODUIT OU DE TOUTE AUTRE MANIÈRE LIÉE AU PRODUIT.
- 4.3 SI PALRAM N'A PAS LE DROIT SELON LA MOINDRE LOI APPLICABLE D'EXCLURE LES GARANTIES SOUS-ENTENDUES DE VALEUR MARCHANDE OU D'ADAPTABILITÉ À UNE FIN SPÉCIFIQUE EN RAPPORT AVEC LE PRODUIT, LA DURÉE D'UNE TELLE GARANTIE EST EXPRESSEMENT LIMITÉE À CELLE DE CETTE GARANTIE OU, SI ELLE EST PLUS LONGUE, À LA PÉRIODE MAXIMALE EXIGÉE PAR LA LOI.
- 4.4 L'ACHETEUR EST LE SEUL RESPONSABLE DANS LA DÉTERMINATION SI LA MANIPULATION, LE STOCKAGE, LE MONTAGE, L'INSTALLATION OU L'UTILISATION DU PRODUIT EST SÛRE ET APPROPRIÉE POUR TOUT ENDROIT, POUR TOUTE APPLICATION DONNÉE OU DANS TOUTE CIRCONSTANCE DONNÉE. PALRAM N'EST PAS RESPONSABLE DE TOUT DOMMAGE OU BLESSURE CAUSÉ À L'ACHETEUR, TOUTE AUTRE PERSONNE OU BIEN RESULTANT D'UNE MANIPULATION, UN STOCKAGE, UNE INSTALLATION, UN MONTAGE OU UNE UTILISATION DU PRODUIT OU UN MANQUE À SUIVRE LES INSTRUCTIONS ÉCRITES CONCERNANT LA MANIPULATION, LE STOCKAGE, LE MONTAGE, L'INSTALLATION OU L'UTILISATION DU PRODUIT.
- 4.5 SAUF SI INDIQUÉ EXPRESSEMENT PAR PALRAM, LE PRODUIT EST DESTINÉ À UN USAGE RESIDENTIEL NORMAL SEULEMENT. PALRAM N'EST PAS RESPONSABLE DE TOUTE PERTE, DOMMAGE, FRAIS OU DÉPENSE RESULTANT D'UNE UTILISATION DU PRODUIT POUR TOUTE FIN QUI N'EST PAS RECOMMANDÉE PAR LES INSTRUCTIONS ÉCRITES OU QUI N'EST PAS PERMISE PAR LA MOINDRE LOI OU AUTRES CODES APPLICABLES DANS L'ENDROIT OU L'ACQUÉREUR UTILISERAIT LE PRODUIT.

FR

## Palrams 7 års Begrænset Garanti

### Produktdetaljer: Have krisecentre og gårdhave dæksler

Palram Applications (1995) Ltd. (Virksomhedsregistreringsnummer: 512106824), registreret på adressen Teradion Industrial Park, M.P Misgav 20174, Israel ("Palram"), garanterer at Produktet ikke lider af materielle eller fabriktionsfejl i en periode på syv år fra købsdatoen, underlagt definitionerne og vilkårene indeholdt i denne garanti.

#### 1. Vilkår

- 1.1 Denne garanti er kun gældende, hvis Produktet er installeret, rengjort, håndteret og vedligeholdt i overensstemmelse med Palrams skrevne anbefalinger.
- 1.2 Uden at afvige fra det ovennævnte, er skade opstået grundet brug af fysisk magt, ukorrekt håndtering, upassende brug, forsømmelig brug, samling eller vedligeholdelse, uheld, indvirken fra fremmedlegemer, vandalisme, forurenende stoffer, ændringer, maling, tilslutning, limning, forsejling, der ikke er i overensstemmelse med brugsvejledningen, eller skade som resultat af rengøring med ikke-kompatible rengøringsmidler og mindre afvigelser ved Produktet ikke dækket af denne garanti.
- 1.3 Denne garanti dækker ikke skade som resultat af "naturens handling", hvilket omfatter, men er ikke begrænset til hagl, storm, tornadoer, orkaner, snestorme, oversvømmelse, følger af brand.
- 1.4 Denne garanti er ugyldig, hvis der benyttes konstruktionsdele og løse dele, der ikke er kompatible med Palrams skrevne anbefalinger.
- 1.5 Denne garanti er kun gældende for Produktets oprindelige køber. Den omfatter ikke andre købere eller brugere af Produktet (inklusive, men ikke begrænset til, enhver person der erhverver Produktet fra den oprindelige køber).

#### 2. Krav og Bekendtgørelser

- 2.1 Ethvert garantikrav skal bekendtgøres skriftligt til Palgram inden for 30 dage, efter opdagelsen af det defekte Produkt, og vedlægges den originale kvittering og denne garanti.
- 2.2 Skadesanmelderen skal lade Palram undersøge Produktet, der er tale om, og selve installationen, mens Produktet stadig befinder sig i sin oprindelige position og ikke er blevet fjernet eller flyttet eller ændret på nogen måde, og/eller lade produktet sende tilbage til Palram for afprøvning.
- 2.3 Palram forbeholder sig retten til selvstændigt at undersøge årsagen til dette funktionssvigt.

#### 3. Erstatning

- 3.1 Hvis et krav i henhold til denne garanti bekendtgøres korrekt og godkendes af Palram, kan køberen, efter Palrams valg, (a) købe et erstatningsprodukt eller del/e, eller (b) modtage refundering for det oprindelige Produkts eller del/es købspris, alt i henhold til den følgende oversigt:

Periode Efter Køb	Erstatningsprodukt eller Del/e	Refundering
Fra købsdato til udgangen af 1. år	Uden beregning	100%
Udgangen af 1. år til udgangen af 2. år	køber vil betale 15% af den oprindelige købspris	85%
Udgangen af 2. år til udgangen af 3. år	køber vil betale 30% af den oprindelige købspris	70%
Udgangen af 3. år til udgangen af 4. år	køber vil betale 45% af den oprindelige købspris	55%
Udgangen af 4. år til udgangen af 5. år	køber vil betale 60% af den oprindelige købspris	40%
Udgangen af 5. år til udgangen af 6. år	køber vil betale 75% af den oprindelige købspris	25%
Udgangen af 6. år til udgangen af 7. år	køber vil betale 85% af den oprindelige købspris	15%

- 3.2 For at undgå tvivl vil beregning for bestemmelse af erstatning for defekt(e) del/e, i henhold til oversigten ovenfor, blive baseret på den defekte dels dækning i forhold til Produktets oprindelige pris. Palram forbeholder sig retten til at levere erstatninger, hvis Produktet, eller nogen del af dette, er utilgængeligt eller forældet.
- 3.3 Denne garanti dækker ikke omkostninger eller udgifter ved fjernelse og installation af Produktet, eller afgifter, eller forsendelsesomkostninger, eller nogen direkte eller indirekte tab, der kan opstå grundet Produktfejl,

#### 4. Almindelige Betingelser og Begrænsninger

- 4.1 UD OVER HVAD DER ER BLEVET SPECIFIKT ANFØRT I DENNE GARANTI, ER ALLE ANDRE GARANTIER, OM UDTRYKT ELLER UNDERFORSTÅET, OMFATTENDE ALLE UNDERFORSTÅEDE GARANTIER VEDRØRENDE SALGBARHED ELLER EGNETHED TIL ET SPECIFIKT FORMÅL UNDTAGET FOR SÅ VIDT LOVEN TILLADER
- 4.2 MED UNDTAGELSE AF, HVOR VI HAR SPECIFIKT ANFØRT DET I DENNE GARANTI, ER PALRAM IKKE ANSVARLIG FOR NOGEN TAB ELLER SKADER, SOM KØBEREN LIDER DIREKTE, INDIREKTE, ELLER SOM EN FØLGE AF BRUG, ELLER PÅ NOGEN ANDEN MÅDE FORBINDELSE TIL PRODUKTET.
- 4.3 HVIS PALRAM UDELUKES FRA, I HENHOLD TIL ENHVER GÆLDENDE LOV, AT UNDTAGE DEN UNDERFORSTÅEDE SALGBARHEDS ELLER EGNETHEDSGARANTI FOR ET SPECIFIKT FORMÅL I FORHOLD TIL PRODUKTET, ER VARIGHEDEN AF ALLE SÅDANNE UNDERFORSTÅEDE GARANTIER UDTRYKKELT BEGRÆNSET TIL VARIGHEDEN AF DENNE GARANTI, ELLER, HVIS LÆNGERE, DEN MAKSIMALE PERIODE KRÆVET AF GÆLDENDE LOVGIVNING.
- 4.4 KØBEREN ER ENEANSVARLIG FOR AT BESLUTTE OM HÅNDTERINGEN, OPBEVARINGEN, SAMLINGEN, INSTALLATIONEN ELLER BRUGEN AF PRODUKTET ER SIKKER OG PASSENDE PÅ ETHVERT OMRÅDE, TIL ENHVER APPLIKATION ELLER UNDER ETHVERT GIVENT FORHOLD. PALRAM ER IKKE ANSVARLIG FOR NOGEN SKADER ELLER KVÆSTELSER KØBER, ENHVER ANDEN PERSON, ELLER EJENDOM MÅTTE LIDE, SOM RESULTAT AF UKORREKT HÅNDTERING, OPBEVARING, INSTALLATION, SAMLING ELLER BRUG AF PRODUKTET ELLER UNDLADELSE AF AT FØLGE DE SKREVNE ANBEFALINGER VEDRØRENDE HÅNDTERING, OPBEVARING, INSTALLATION, SAMLING OG BRUG AF PRODUKTET.
- 4.5 MEDMINDRE ANDET ER UDTRYKKELT ANGIVET AF PALRAM, ER PRODUKTET KUN BEREGNET TIL ALMINDELIG BOLIGFORMÅL. PALRAM ER IKKE ANSVARLIG FOR TAB, SKADE, OMKOSTNINGER ELLER UDGIFTER SOM RESULTAT AF NOGEN BRUG AF PRODUKTET TIL NOGET, DER IKKE ER ANBEFALET I DE SKREVNE ANBEFALINGER, ELLER IKKE ER TILLADT I HENHOLD TIL NOGEN GÆLDENDE LOVGIVNING ELLER ANDRE GÆLDENDE REGLER PÅ DET STED, HVOR KØBER VIL BRUGE PRODUKTET.

DA

## Begränsningar i Palrams 7-års garanti

### Produktinformation: Trädgård vindskydd och uteplats omslag

Palram Applications (1995) Ltd (Bolagsnummer: 512106824) vars registrerade huvudkontor har adressen: Teradion Industrial Park, M.P Misgav 20174, Israel ("Palram") garanterar att produkten är felfri avseende material och bearbetning under en period av 7 år från inköpsdagen i enlighet med definitionerna och villkoren i denna garanti.

#### 1. Villkor

- 1.1 Denna garanti gäller endast produkter som installerats, skötts, underhållits och hållits rena enligt anvisningarna i Palrams handbok.
- 1.2 Övan nämnda garanti gäller inte vid skador till följd av alltför kraftig användning, fel eller olämplig användning, vårdslös installering, vårdslöst bruk eller underhåll, missöden, skador som frammande föremål gett upphov till, skadegörelse, smuts, förändringar, målning, fogar, limning, tejpnin, olämpliga tätningar eller skador som uppkommit på grund av olämpliga rengöringsmedel. Små avvikelser omfattas inte av garantin.
- 1.3 Garantin täcker inte naturfenomen eller skador orsakade av dessa, såsom hagel, tung snö, storm, virvelvindar, orkaner, blixnar, vind eller översvämningar.
- 1.4 Garantin gäller inte om man för växuset använder olämpliga byggsatser eller komponenter som inte rekommenderas av tillverkaren (Palram).
- 1.5 Garantin gäller endast den ursprungliga köparen/mottagaren. Garantin kan inte överföras till följande ägare eller en annan användare. taikka seuraaville omistajille.

#### 2. Reklamationer och anmälningar

- 2.1 Varje garantianspråk måste underrättas skriftligen till Palram inom 30 dagar efter upptäckten av en defekt produkt, innehållande originalkvittot för försäljningen och den här garantin.
- 2.2 Käranden (den som gjort reklamationen) ska låta tillverkaren/tillverkarens företrädare granska den felaktiga produkten på produktens ursprungliga plats i det skick som den är efter skadan. Produkten får inte ändras, repareras, flyttas eller skickas till tillverkaren/företrädaren innan tillstånd för detta har getts.
- 2.3 Tillverkaren (Palram) förbehåller sig rätten att självständigt undersöka orsaken till felet.

#### 3. Ersättning

- 3.1 När reklamationen har anmälts enligt villkoren i garantin och godkänts av Palram har köparen (käranden) rätt att få nya delar eller en ny produkt eller en ersättning som står i proportion till skadan och anskaffningspriset enligt följande tabell:

Tid sedan anskaffning	Ersättande produkt/del	Ersättning
1 år sedan anskaffning	Utan avgift	100%
1 => 2 år sedan anskaffning	Självrisk andel 15%	85%
2 => 3 år sedan anskaffning	Självrisk andel 30%	70%
3 => 4 år sedan anskaffning	Självrisk andel 45%	55%
4 => 5 år sedan anskaffning	Självrisk andel 60%	40%
5 => 6 år sedan anskaffning	Självrisk andel 75%	25%
6 => 7 år sedan anskaffning	Självrisk andel 85%	15%

- 3.2 För att undvika alla misstankar, felkalkyleringar eller missförstånd vad gäller ersättning, beräknas den i tabellen framställda ersättningen alltid enligt den andel som den felaktiga/skadade delen utgör av hela produktens anskaffningspris. Tillverkaren förbehåller sig rätten att leverera en ersättande produkt/produkt del om originaldelar inte längre är tillgängliga eller om delarna eller produkterna är föråldrade.
- 3.3 Garantin ersätter inte utgifter som orsakats av installering, nedmontering, flyttning eller reparation av produkten och inte heller utgifter som orsakats av direkta eller indirekta utgifter och förluster för att produkten haft fel eller skador, t.ex. skatter, flyttavgifter, leverans- och sändningsavgifter.
4. **Allmänna villkor och begränsningar**
- 4.1 UTÖVER VAD SOM UTTRYCKLIGEN NÄMNS I DENNA GARANTI ÄR ALLA ÖVRIGA GARANTIER ALLMÄNT BINDANDE VERKAN DIREKT ELLER INDIREKT GÄLLANDE ALLMÄN ELLER SÄRSKILD TILLÄMPNING UTESLUTNA INOM LAGENS RAMAR.
- 4.2 MED UNDANTAG AV VAD SOM NÄMNS I DESSA GARANTIVILLKOR, ANSVARAR TILLVERKAREN INTE FÖR DE FÖRLUSTER ELLER SKADOR SOM KÖPAREN ELLER ANVÄNDAREN AV PRODUKTEN DIREKT ELLER INDIREKT ELLER TILL FÖLJD AV ANVÄNDNINGEN AV ELLER KONTAKTEN MED PRODUKTEN DRABBAS AV.
- 4.3 OM TILLVERKAREN ENLIGT LOKAL LAGSTIFTNING ELLER UTIFRÅN KONSUMENTSKYDDETS REKOMMENDATIONER NEKATS ATT INNEHÅLLA ERSÄTTNINGAR, TILLÄMPAS MED TANKE PÅ GARANTIER OM ALLMÄN ELLER SÄRSKILD TILLÄMPNING, GARANTIERNAS GILTIGHETSTID ENLIGT LOKAL LAGSTIFTNING PÅ PRODUKTEN.
- 4.4 KÖPAREN ÄR ENSAM ANSVARIG FÖR ATT PRODUKTEN HANTERAS, FÖRVARAS OCH MONTERAS ÄNDAMÅLSENLIGT SAMT FÖR ATT DEN PLACERAS PÅ ETT TRYGGT SÄTT. PALRAM ÄR INTE ANSVARIG FÖR NÅGRA MISSÖDEN ELLER SKADOR SOM ORSAKAS KÖPAREN, ANNAN PERSON ELLER PART ELLER DERAS EGENDOM OM DE BEROR PÅ ATT PRODUKTEN HANTERATS, FÖRVARATS, INSTALLERATS, MONTERATS PÅ FEL SÄTT ELLER PÅ GRUND AV ATT PRODUKTEN ANVÄNTS PÅ FEL SÄTT ELLER ATT ANVISNINGARNA INTE IAKT TAGITS.
- 4.5 PALRAMS TILLVERKADE PRODUKT ÄR AVSEDD FÖR NORMALT BRUK PÅ GÅRDSPLANER OM INTE ANNAT ANGES. OM ANVÄNDNINGEN AV PRODUKTEN ENLIGT LOKAL LAGSTIFTNING ELLER ANDRA BESTÄMMELSER PÅ DEN PLATS DÄR KÖPAREN ANVÄNDER PRODUKTEN INTE ÄR TILLÅTEN, ANSVARAR PALRAM INTE FÖR NÅGRA FÖRLUSTER, OLYCKSHÄNDELSER, KOSTNADER ELLER UTGIFTER SOM BEROR PÅ ATT PRODUKTEN ANVÄNTS PÅ FEL SÄTT, OBEROENDE AV FÖR VILKET ÄNDAMÅL PRODUKTEN ANVÄNTS.

SV

## Περιορισμένη εγγύηση 7 ετών

### Λεπτομέρειες: Καταφύγια κήπο και αίθριο καλύμματα

Η εταιρεία Palram Εφαρμογές (1995) Ltd (αριθμός Εταιρεία: 512106824), η έδρα της οποίας βρίσκεται στο Teradion Industrial Park, MP Misgav 20174, Ισραήλ ("Palram") εγγυάται ότι το προϊόν δεν θα είναι ελαττωματικά υλικά ή την εργασία για μια περίοδο επτά ετών από την αρχική την ημερομηνία της αγοράς, σύμφωνα με τους ορισμούς, τους όρους και τις προϋποθέσεις που εμπεριέχονται στην παρούσα εγγύηση.

#### 1. Συνθήκες

- 1.1 Αυτή η εγγύηση ισχύει μόνο αν το Προϊόν εγκαθίσταται, καθαρίζεται, χρησιμοποιείται και συντηρείται σύμφωνα με τις γραπτές συστάσεις της Palram.
- 1.2 Χωρίς να παρεκκλίνουμε από τα παραπάνω, δεν καλύπτονται από αυτή την εγγύηση η ζημιά που προκαλείται από τη χρήση δύναμης, μη ορθό χειρισμό, ακατάλληλη χρήση, απρόσεκτη χρήση ή συναρμολόγηση ή συντήρηση, ατυχήματα, κρούση από ξένα σώματα, βανδαλισμό, ρύπους, αλλαγές, βαφή, σύνδεση, κόλλημα, σφράγισμα που γίνεται χωρίς συμβατότητα με το χειρίδιο χρήστη ή ζημιά που προκύπτει από καθαρισμό με μη συμβατά καθαριστικά και μικρές αποκλίσεις του Προϊόντος.
- 1.3 Η εγγύηση αυτή δεν εφαρμόζεται για ζημιές που προκύπτουν από "άνωτερη βία", οι οποίες περιλαμβάνουν αλλά δεν περιορίζονται σε, χαλάζι, καταιγίδα, ανεμοστρόβιλο, θύελλα, χιονοθύελλες, πλημμύρα, αποτελέσματα πυρκαγιάς.
- 1.4 Η εγγύηση αυτή δεν ισχύει αν τα δομικά μέρη και τα συστατικά που χρησιμοποιούνται δεν είναι συμβατά με τις γραπτές συστάσεις της Palram
- 1.5 Η εγγύηση αυτή εφαρμόζεται μόνο για τον αρχικό αγοραστή του Προϊόντος. Δεν ισχύει για οποιονδήποτε άλλο αγοραστή ή χρήστη του Προϊόντος (συμπεριλαμβανομένων, αλλά όχι περιορισμένων, οποιοδήποτε ατόμων που αποκτήσουν το Προϊόν από τον αρχικό αγοραστή).
2. **Αξιώσεις και Ειδοποιήσεις**
- 2.1 Κάθε αίτηση αποζημίωσης λόγω εγγύησης θα πρέπει να αποσταλεί γραπτώς στην Palram εντός 30 ημερών από την ανακάλυψη του ελαττωματικού προϊόντος, επισυνάπτοντας την αρχική απόδειξη αγοράς καθώς και την παρούσα εγγύηση.
- 2.2 Ο αιτών πρέπει να επιτρέψει στην Palram να εξετάσει το εν λόγω Προϊόν και το σημείο της εγκατάστασης ενώ το Προϊόν βρίσκεται στην αρχική του θέση και δεν έχει μετακινηθεί ή αφαιρεθεί ή αλλαχθεί με οποιοδήποτε τρόπο ή/και να επιστρέψει το Προϊόν στην Palram για εξέταση.
- 2.3 Η Palram δεσμεύει το δικαίωμα να εξετάσει ανεξάρτητα την αιτία οποιουδήποτε προβλήματος.
3. **Αποζημίωση**
- 3.1 Αν μια αξίωση υπό αυτή την Εγγύηση, ειδοποιηθεί ορθά και την εγκρίνει η Palram, ο αγοραστής, με την επιλογή της Palram, μπορεί είτε να (α) αγοράσει ένα Προϊόν ή μέρος/-η ως αντικατάσταση ή (β) να λάβει αποζημίωση της τιμής του αρχικού Προϊόντος ή μέρος/-η αυτής, όλα σύμφωνα με το ακόλουθο χρονοδιάγραμμα:

Περίοδος μετά από την αγορά	Προϊόν ή μέρος/-η ως αντικατάσταση	Επιστροφή
Από την ημερομηνία αγοράς ως το τέλος του 1ου έτους	Χωρίς χρέωση	100%
Τέλος του 1ου έτους ως το τέλος του 2ου έτους	ο αγοραστής θα πληρώσει το 15% της αρχικής τιμής αγοράς	85%
Τέλος του 2ου έτους ως το τέλος του 3ου έτους	ο αγοραστής θα πληρώσει το 30% της αρχικής τιμής αγοράς	70%
Τέλος του 3ου έτους ως το τέλος του 4ου έτους	ο αγοραστής θα πληρώσει το 45% της αρχικής τιμής αγοράς	55%
Τέλος του 4ου έτους ως το τέλος του 5ου έτους	ο αγοραστής θα πληρώσει το 60% της αρχικής τιμής αγοράς	40%
Τέλος του 5ου έτους ως το τέλος του 6ου έτους	ο αγοραστής θα πληρώσει το 75% της αρχικής τιμής αγοράς	25%
Τέλος του 6ου έτους ως το τέλος του 7ου έτους	ο αγοραστής θα πληρώσει το 85% της αρχικής τιμής αγοράς	15%

- 3.2 Για να αποφευχθούν τυχόν απορίες, ο υπολογισμός για την αποζημίωση για τα ελαττωματικά μέρη, σύμφωνα με τον παραπάνω πίνακα, θα βασιστεί στο μερίδιο του ελαττωματικού μέρους σε σχέση με την αρχική τιμή του Προϊόντος. Η Palram δεσμεύει το δικαίωμα να παράσχει αντικαταστάσεις αν το Προϊόν ή οποιοδήποτε μέρος του δεν είναι διαθέσιμο ή αν δεν υπάρχει.
- 3.3 Η εγγύηση αυτή δεν καλύπτει οποιοδήποτε κόστος και έξοδα αφαίρεσης και εγκατάστασης του Προϊόντος ή φόρους ή έξοδα αποστολής ή οποιοσδήποτε άμεσος ή έμμεσος ζημιές οι οποίες προκύπτουν από μη λειτουργία του Προϊόντος.
4. **Γενικές συνθήκες και περιορισμοί**
- 4.1 ΕΚΤΟΣ ΑΠΟ ΟΣΑ ΕΧΟΥΝ ΑΝΑΦΕΡΘΕΙ ΕΙΔΙΚΑ ΣΕ ΑΥΤΗ ΤΗΝ ΕΓΓΥΗΣΗ, ΟΛΕΣ ΟΙ ΑΛΛΕΣ ΕΓΓΥΗΣΕΙΣ, ΕΙΤΕ ΡΗΤΕΣ Ή ΕΜΜΕΣΕΣ, ΣΥΜΠΕΡΙΛΑΜΒΑΝΟΜΕΝΩΝ ΟΛΩΝ ΤΩΝ ΕΜΜΕΣΩΝ ΕΓΓΥΗΣΕΩΝ ΕΜΠΟΡΙΣΙΜΟΤΗΤΑΣ Ή ΚΑΤΑΛΗΛΟΤΗΤΑΣ ΓΙΑ ΕΝΑ ΣΥΓΚΕΚΡΙΜΕΝΟ ΣΚΟΠΟ ΕΞΑΙΡΟΥΝΤΑΙ ΑΠΟ ΟΣΑ ΕΠΙΤΡΕΠΕΙ Ο ΝΟΜΟΣ.
- 4.2 ΕΚΤΟΣ ΑΠΟ ΠΕΡΙΠΤΩΣΕΙΣ ΠΟΥ ΕΧΟΥΜΕ ΑΝΑΦΕΡΕΙ ΡΗΤΑ ΣΕ ΑΥΤΗ ΤΗΝ ΕΓΓΥΗΣΗ, Η PALRAM ΔΕΝ ΕΙΝΑΙ ΥΠΕΥΘΥΝΗ ΓΙΑ ΟΠΟΙΕΣΔΗΠΟΤΕ ΑΠΟΛΕΙΞΕΙ Η ΖΗΜΙΕΣ ΠΟΥ Ο ΑΓΟΡΑΣΤΗΣ ΜΠΟΡΕΙ ΝΑ ΔΕΧΘΕΙ ΑΜΕΣΑ, ΕΜΜΕΣΑ Ή ΩΣ ΣΥΝΕΠΕΙΑ ΤΗΣ ΧΡΗΣΗΣ, Ή ΣΥΝΔΕΟΜΕΝΕΣ ΜΕ ΟΠΟΙΟΔΗΠΟΤΕ ΤΡΟΠΟ ΜΕ ΤΟ ΠΡΟΪΟΝ.
- 4.3 ΑΝ Η PALRAM ΑΠΟΓΟΡΕΥΕΤΑΙ ΥΠΟ ΟΠΟΙΟΔΗΠΟΤΕ ΕΦΑΡΜΟΣΤΕΟ ΝΟΜΟ ΝΑ ΕΞΑΙΡΕΣΕΙ ΤΙΣ ΕΜΜΕΣΕΣ ΕΓΓΥΗΣΕΙΣ ΕΜΠΟΡΕΥΜΑΤΟΠΟΙΗΣΗΣ Ή ΚΑΤΑΛΗΛΟΤΗΤΑΣ ΓΙΑ ΕΝΑΝ ΣΥΓΚΕΚΡΙΜΕΝΟ ΣΚΟΠΟ ΣΕ ΣΧΕΣΗ ΜΕ ΤΟ ΠΡΟΪΟΝ, Η ΔΙΑΡΚΕΙΑ ΟΠΟΙΟΔΗΠΟΤΕ ΕΜΜΕΣΩΝ ΕΓΓΥΗΣΕΩΝ ΠΕΡΙΟΡΙΖΕΤΑΙ ΡΗΤΑ ΣΤΗ ΠΕΡΙΟΔΟ ΑΥΤΗΣ ΤΗΣ ΕΓΓΥΗΣΗΣ Ή, ΑΝ Η ΠΕΡΙΟΔΟΣ ΕΙΝΑΙ ΜΕΓΑΛΥΤΕΡΗ, ΣΤΗΝ ΜΕΓΙΣΤΗ ΠΕΡΙΟΔΟ ΠΟΥ ΑΠΑΙΤΕΙ Ο ΕΦΑΡΜΟΣΤΕΟΣ ΝΟΜΟΣ.
- 4.4 Ο ΑΓΟΡΑΣΤΗΣ ΕΙΝΑΙ Ο ΜΟΝΟΣ ΥΠΕΥΘΥΝΟΣ ΓΙΑ ΝΑ ΚΑΘΟΡΙΣΕΙ ΑΝ Η ΧΡΗΣΗ, ΑΠΟΘΗΚΕΥΣΗ, ΣΥΝΑΡΜΟΛΟΓΗΣΗ, ΕΓΚΑΤΑΣΤΑΣΗ Η ΧΡΗΣΗ ΤΟΥ ΠΡΟΪΟΝΤΟΣ ΕΙΝΑΙ ΑΣΦΑΛΗΣ ΚΑΙ ΚΑΤΑΛΗΛΗ ΓΙΑ ΟΠΟΙΟΔΗΠΟΤΕ ΤΟΠΟΘΕΣΙΑ, ΓΙΑ ΟΠΟΙΟΔΗΠΟΤΕ ΕΦΑΡΜΟΓΗ Η ΣΕ ΟΠΟΙΟΔΗΠΟΤΕ ΠΕΡΙΣΤΑΣΗ. Η PALRAM ΔΕΝ ΕΙΝΑΙ ΥΠΕΥΘΥΝΗ ΓΙΑ ΟΠΟΙΕΣΔΗΠΟΤΕ ΖΗΜΙΕΣ Η ΤΡΑΥΜΑΤΙΣΜΟ ΣΤΟΝ ΑΓΟΡΑΣΤΗ, ΣΕ ΟΠΟΙΟΔΗΠΟΤΕ ΑΛΛΟ ΑΤΟΜΟ Η ΙΔΙΟΚΤΗΣΙΑ ΟΙ ΟΠΟΙΕΣ ΠΡΟΚΥΠΤΟΥΝ ΑΠΟ ΑΚΑΤΑΛΛΗΛΟ ΧΕΙΡΙΣΜΟ, ΑΠΘΗΚΕΥΣΗ, ΕΓΚΑΤΑΣΤΑΣΗ, ΣΥΝΑΡΜΟΛΟΓΗΣΗ Η ΧΡΗΣΗ ΤΟΥ ΠΡΟΪΟΝΤΟΣ Ή ΜΗ ΣΥΜΜΟΡΦΩΣΗ ΜΕ ΤΙΣ ΓΡΑΠΤΕΣ ΟΔΗΓΙΕΣ ΣΧΕΤΙΚΑ ΜΕ ΤΗΝ ΧΡΗΣΗ, ΑΠΘΗΚΕΥΣΗ ΣΥΝΑΡΜΟΛΟΓΗΣΗ, ΕΓΚΑΤΑΣΤΑΣΗ ΚΑΙ ΧΡΗΣΗ ΤΟΥ ΠΡΟΪΟΝΤΟΣ.
- 4.5 ΕΚΤΟΣ ΑΠΟ ΠΕΡΙΠΤΩΣΕΙΣ ΡΗΤΕΣ ΕΚΦΡΑΣΗΣ ΑΠΟ ΤΗΝ PALRAM, ΤΟ ΠΡΟΪΟΝ ΠΡΟΟΡΙΖΕΤΑΙ ΜΟΝΟ ΓΙΑ ΚΑΝΟΝΙΚΗ ΟΙΚΙΑΚΗ ΧΡΗΣΗ. Η PALRAM ΔΕΝ ΕΙΝΑΙ ΥΠΕΥΘΥΝΗ ΓΙΑ ΟΠΟΙΟΔΗΠΟΤΕ ΑΠΟΛΕΙΑ, ΖΗΜΙΑ, ΚΟΣΤΟΣ Ή ΕΞΟΔΑ ΠΟΥ ΠΡΟΚΥΠΤΟΥΝ ΑΠΟ ΟΠΟΙΟΔΗΠΟΤΕ ΧΡΗΣΗ ΤΟΥ ΠΡΟΪΟΝΤΟΣ ΓΙΑ ΟΠΟΙΟΔΗΠΟΤΕ ΑΛΛΟ ΣΚΟΠΟ ΠΟΥ ΔΕΝ ΕΙΣΤΗΝΕΤΑΙ ΑΠΟ ΓΡΑΠΤΕΣ ΟΔΗΓΙΕΣ Ή ΠΟΥ ΔΕΝ ΕΠΙΤΡΕΠΕΙ ΑΠΟ ΟΠΟΙΟΔΗΠΟΤΕ ΕΦΑΡΜΟΣΜΕΝΗ ΝΟΜΟΘΕΣΙΑ Η ΑΛΛΟΣ ΚΩΔΙΚΣ ΠΟΥ ΙΣΧΥΟΥΝ ΣΤΗΝ ΤΟΠΟΘΕΣΙΑ ΠΟΥ Ο ΑΓΟΡΑΣΤΗΣ ΘΑ ΧΡΗΣΙΜΟΠΟΙΗΣΕΙ ΤΟ ΠΡΟΪΟΝ.

EL

## Palram´n 7 vuoden rajoitetut takuuehdot

### Tuotetiedot: Puutarha turvakoteja ja patio kannet

Palram Applications (1995) Ltd (yhtiön rek.nro 512106824) jonka päätoimipiste toimii osoitteessa Teradion Industrial Park, M.P Misgav 20174, Israel. Palram taakeita, että se valmistamissa tuotteissa ei sisälly virheitä materiaali- tai valmistusvirheitä, ja seuraavan seitsemän vuoden aikana alkuperäisestä ostopäivästä, joita on raportoitu olosuhteissa.

#### 1. Olosuhteet

- 1.1 Tämä takuu on voimassa vain tuotteelle joka on ohjeen mukaisesti asennettu, hoidettu & ylläpidetty sekä pidetty puhtaana Palramin ohjekirjassa antamien ohjeiden mukaisesti.
- 1.2 Poikkeamatta edellä mainitusta, vauriot jotka ovat syntyneet liiallisesta voiman käytöstä, vääärästä tai sopimattomasta käytöstä, huolimattomasta asennuksesta, käytöstä tai ylläpidosta, vahingoista, vieraiden esineiden kolkhuista, ilkivallasta epäpuhtauksista, muutoksista, maalauksista, liitoksista, liimauksista, teippauksista, sopimattomista tiivistyksistä tai vaurioista jotka ovat syntyneet yhteensopimattomista puhdistusaineista. Pienet poikkeamat eivät kuulu tämän takuun piiriin.
- 1.3 Tämä takuu ei kata luonnonilmiöitä taikka niistä syntyneitä vaurioita kuten rakeet, raskas lumi, myrsky, yöpölymyrsky, hirmumyrsky, salammat, tuli taikka tulva.
- 1.4 Tämä takuu on mitätön mikäli kasvihuoneen kanssa käytetään yhteensopimattomia rakenneosia taikka komponentteja jotka eivät ole valmistajan (Palram) suosituksen mukaisia.
- 1.5 Tämä takuu on ainoastaan voimassa alkuperäiselle ostajalle / saajalle. Se ei ole jatkettavissa tai siirrettävissä toisille käyttäjille taikka seuraaville omistajille.

#### 2. Reklamaatiot ja ilmoitukset

- 2.1 Kaikki takuuvaihtumukset on tehtävä kirjallisesti Palramille 30 päivän sisällä viallisen tuotteen huomaamisesta, ja mukaan on liitettävä alkuperäinen ostokuitti ja tämä takuu.
- 2.2 Kantajan (reklamaation tehnyt) tulee sallia valmistajan / valmistajan edustajan tarkistaa vioittunut tuote sen alkuperäisessä sijainnissa siinä kunnossa kuin se on vaurion sattumisen jälkeen. Tuotetta ei saa muunnella, korjata, siirtää taikka lähettää valmistajalle / edustajalle ennen siihen saatua lupaa.
- 2.3 Valmistaja (Palram) varaa oikeuden saada itsenäisesti tutkia vian syy.

#### 3. Korvaus

- 3.1 Mikäli reklamaatio on takuun mukaisesti ilmoitettu ja hyväksytty Palramilta, on ostaja (kantaja) oikeutettu joko korvaaviin osiin / tuotteeseen taikka hyvitykseen joka on suhteessa vahinkoon & hankintahintaan seuraavan taulukon mukaisesti:

Aikaa hankinnasta	Korvaava tuote ja / tai osa	Korvaus
1 vuosi hankinnasta	Veloituksetta	100%
1 => 2´teen vuoteen hankinnasta	Omavastuu 15%	85%
2 => 3´teen vuoteen hankinnasta	Omavastuu 30%	70%
3 => 4´teen vuoteen hankinnasta	Omavastuu 45%	55%
4 => 5´teen vuoteen hankinnasta	Omavastuu 60%	40%
5 => 6´teen vuoteen hankinnasta	Omavastuu 75%	25%
6 => 7´teen vuoteen hankinnasta	Omavastuu 85%	15%

- 3.2 Välttyäkseen miltään epäilyiltä, laskentavirheitä tai väärinkäsityksiltä korvattavuuden suhteen edellä esitetyn taulukon mukainen korvaus lasketaan aina viallisen / vioittuneen osan osuudesta kokonaistuotteen hankinta-arvosta. Valmistaja varaa oikeuden toimittaa korvaava tuote / tuoteposa mikäli alkuperäistä osaa ei ole enää saatavissa tai se on vanhentunut.
- 3.3 Tämä takuu ei korvaa kuluja jotka ovat syntyneet asennuksesta, purkauksesta, tuotteen siirtämisestä tai korjaustyöstä eikä myöskään suorista tai epäsuorista kuluista & menetyksistä kuten veroista, muutoista, toimitus- & lähetyskuluista jotka ovat syntyneet tuotteen viallisuudesta tai vioittuneisuudesta.

#### 4. Yleiset ehdot ja rajoitukset

- 4.1 MUILTA OSIN KUIN NIMENOMAISESTI TÄSSÄ TAKUUSSA ON ESITETTY, KAIKKIEN MUIDEN TAKUIDEN YLEISSITOUVUDET KAUPALLISESTA HYÖDYNNETTÄVYDESTÄ TAI SOPIVUUDESTA SUORAAN TAI VÄLILLISESTI OVAT POISSULJETTU SIKÄLI KUIN LAKI SALLII.
- 4.2 POISLUKIEK MITÄ NÄISSÄ TAKUUEHDOISSA ON ESITETTY, VALMISTAJA EI VASTAA MISTÄÄN TAPPIOISTA TAI VAHINGOISTA MITÄ OSTAJA TAI TUOTTEEN KÄYTTÄJÄ KÄRSI SUORAAN, VÄLILLISESTI TAI SEURAUKSENA TUOTTEEN KÄYTTÄMISESTÄ TAI YHTEYDESTÄ TUOTTEESEEN.
- 4.3 MIKÄLI VALMISTAJAA ON KIELLETTY EVÄTÄ PAIKALLISESTI SOVELLETTAVAN LAINSÄÄDÄNNÖN TAI KULUTTANSUOJA SUOSITUSTEN POHJALTA TAKUUEHTOJEN MUKAISIA KORVAUKSIA – SOVELLETAAN YLEISESTI KAUPALLISESTI HYÖDYNNETTÄVYDESTÄ TAI SOPIVUUDESTA TIETYYN TARKOITUKSEEN NÄHDEN TUOTTEEN OLEVAN TAKUIDEN VOIMASSAOLOAIKAA PAIKALLISEN LAIN MUKAAN.
- 4.4 OSTAJA ON YKSIN VASTUUSSA ASIANMUKAISESTA KÄSITTELYSTÄ, VARASTOINNISTA, KOKOONPANOSTA SEKÄ TURVALLISESTA SJAINNISTAETÄÄ KÄYTTÖSTÄ JA SÄILYTUKSESTÄ. PALRAM EI OLE VASTUUSSA MISTÄÄN VAHINGOISTA TAI VAMMOISTA OSTAJALLE, MUULLE HENKILÖLLE TAI OSAPUOLELLE TAI HÄNEN OMAISUUDELLE MIKÄLI NE JOHTUVAT VÄÄRÄSTÄ KÄSITTELYSTÄ, VARASTOINNISTA, ASENNUKSESTA, KOKOAMISESTA TAI TUOTTEEN VÄÄRÄSTÄ KÄYTTÖSTÄ TAI OHJEIDEN NOUDATTAMATTA JÄTTÄMISESTÄ.
- 4.5 PALRAMIN VALMISTAMA TUOTE ON TARKOITETTU NORMAALIIN ASUIMISTON PIHÄKÄYTTÖÖN ELLEI TOISIN OLE MERKITYY. PALRAM EI OLE VASTUUSSA MISTÄÄN MENETYKSESTÄ, VAHINGOSTA, KUSTANNUKSISTA TAI KULUISTA JOTKA JOHTUVAT TUOTTEEN VÄÄRÄSTÄ KÄYTTÖSTÄ MIHIN TAHANSA TARKOITUKSEEN, MIKÄLI EI OLLA NOUDATETTU SUOSITELTUJA KIRJALLISIA OHJEITA TAI JOS KÄYTTÖ EI OLE SALLITTUA SOVELLETTAVAN LAINSÄÄDÄNNÖN TAI MUIDEN ASETUSTEN MUKAAN PAIKASSA JOSSA OSTAJA KÄYTTÄÄ TUOTETTA.

FI

## PALRAM ´s 7 jaars beperkte garantie

### Productgegevens: Tuinhuisjes en patio covers

Palram Applications (1995) Ltd (Bedrijfsnummer: 512106824) met maatschappelijke zetel te Teradion Industrial Park, M.P Misgav 20174, Israël ("Palram") garandeert dat het product vrij is van materiaal-en fabricagefouten voor een periode van zeven jaar vanaf de oorspronkelijke datum van aankoop door de definities en voorwaarden van deze garantie.

#### 1. Voorwaarden

- 1.1 Deze garantie is alleen geldig indien het Product is geïnstalleerd, gereinigd, gebruikt en onderhouden in overeenstemming met de geschreven aanbevelingen van Palram.
- 1.2 Zonder af te wijken van het bovenstaande, zal schade veroorzaakt door gebruik van geweld, onjuist gebruik, oneigenlijk gebruik, nalatig gebruik of montage of onderhoud, ongevallen, botsing met vreemde voorwerpen, vandalisme, vervuiling, aanpassingen, schilderen, verbinden, lijmen, afdichten op een wijze die niet in overeenstemming is met de handleiding, of schade als gevolg van reiniging met incompatibele schoonmaakmiddelen en geringe afwijkingen van het Product niet vallen onder deze garantie.
- 1.3 Deze garantie geldt niet voor schade als gevolg van "overmacht", inclusief maar niet beperkt tot, hagel, onweer, tornado's, orkanen, sneeuwstormen, overstromingen, gevolgen van brand.
- 1.4 Deze garantie vervalt als structurele onderdelen en onderdelen die worden gebruikt niet compatibel zijn met schriftelijke aanbevelingen van Palram.
- 1.5 Deze garantie geldt alleen voor de oorspronkelijke koper van het Product. Zij geldt niet voor een andere koper of gebruiker van het Product (inclusief, maar niet beperkt tot, elke persoon die het product koopt van de oorspronkelijke koper).

#### 2. Claims en meldingen

- 2.1 Elke garantielaan dient bij Palram te worden ingediend binnen 30 dagen na de ontdekking van het defecte product, met bijvoeging van het originele koopbewijs en deze garantie.
- 2.2 De eiser moet het Palram mogelijk maken het betrokken product en de constructielocatie zelf te inspecteren, met het product nog in de oorspronkelijke positie en niet verwijderd of verplaatst of op enigerlei wijze veranderd en/of het product terugzenden naar Palram om te laten testen.
- 2.3 Palram behoudt zich het recht om zelfstandig de oorzaak van een probleem te onderzoeken.

#### 3. Compensatie

- 3.1 Indien een claim onder deze garantie goed is aangemeld en door Palram is goedgekeurd, mag de koper, naar Palrams keuze, ofwel (a) een vervangend product of onderde(e)l/en aanschaffen, of (b) het aankoopbedrag van het oorspronkelijke product of onderde(e)l/en terugkrijgen, alles in overeenstemming met het volgende schema:

Periode na aankoop	vervangende product of onderde(e)l/en Teruggave	Teruggave
Vanaf de aankoopdatum tot het eind van 1e jaar	Gratis	100%
Einde van 1 <sup>e</sup> jaar tot einde van 2 <sup>e</sup> jaar	koper betaalt 15% van het oorspronkelijke aankoopbedrag	85%
Einde van 2 <sup>e</sup> jaar tot einde van 3 <sup>e</sup> jaar	koper betaalt 30% van het oorspronkelijke aankoopbedrag	70%
Einde van 3 <sup>e</sup> jaar tot einde van 4 <sup>e</sup> jaar	koper betaalt 45% van het oorspronkelijke aankoopbedrag	55%
Einde van 4 <sup>e</sup> jaar tot einde van 5 <sup>e</sup> jaar	koper betaalt 60% van het oorspronkelijke aankoopbedrag	40%
Einde van 5 <sup>e</sup> jaar tot einde van 6 <sup>e</sup> jaar	koper betaalt 75% van het oorspronkelijke aankoopbedrag	25%
Einde van 6 <sup>e</sup> jaar tot einde van 7 <sup>e</sup> jaar	koper betaalt 85% van het oorspronkelijke aankoopbedrag	15%

- 3.2 Voor alle duidelijkheid, de berekening voor de bepaling van de compensatie voor defecte onderde(e)l/en, volgens het bovenstaande schema, zal worden gebaseerd op de bijdrage van het defecte onderdeel op de oorspronkelijke kosten van het product. Palram behoudt zich het recht voor vervangingen te leveren indien het product of enig deel daarvan niet beschikbaar of verouderd is.
- 3.3 Deze garantie dekt geen kosten en uitgaven van de verwijdering en installatie van het Product of belastingen of verzendkosten of enige andere directe of indirecte schade(s) die kan/kunnen voortvloeien uit het defect van het product.

#### 4. Algemene voorwaarden en beperkingen

- 4.1 ANDERS DAN SPECIFIEK IN DEZE GARANTIE AANGEGEVEN, ZIJN ALLE ANDERE GARANTIES, HETZIJ EXPLICIET OF IMPLICIET, INCLUSIEF ALLE IMPLICIETE GARANTIES VAN VERKOOPBAARHEID OF GESCHIKTHEID VOOR EEN BEPAALD DOEL UITGESLOTEN VOOR ZOVER DE WET DIT TOELAAT.
- 4.2 BEHALVE WAAR WE DAT SPECIFIEK HEBBEN AANGEGEVEN IN DEZE GARANTIE, ZAL PALRAM NIET VERANTWOORDELIJK VOOR VERLIES OF SCHADE DIE DE KOPER LIJDT, DIRECT OF INDIRECT, OF ALS GEVOLG VAN HET GEBRUIK, OF OP WELKE ANDERE WIJZE DAN OOK IN VERBAND MET HET PRODUCT.
- 4.3 ALS HET PALRAM VERBODEN IS ONDER DE TOEPASSELIJKE WETGEVING DE GARANTIES VAN VERKOOPBAARHEID OF GESCHIKTHEID UIT TE SLUITEN VOOR EEN BEPAALD DOEL MET BETREKKING TOT HET PRODUCT, IS DE DUUR VAN ALLE DERGELIJKE IMPLICIETE GARANTIES UITDRUKKELIJK BEPERKT TOT DE DUUR VAN DEZE GARANTIE OF, INDIEN LANGER, TOT DE MAXIMALE PERIODE VEREIST IN DE TOEPASSELIJKE WETGEVING.
- 4.4 DE KOPER IS ZELF GEHEEL VERANTWOORDELIJK OM TE BEPALEN OF HET HANTEREN, DE OPSLAG, MONTAGE, INSTALLATIE OF HET GEBRUIK VAN HET PRODUCT OP ELKE LOCATIE VEILIG EN PASSEND IS, GESCHIKT IS VOOR HET DOEL OF PASSEND ONDER DE GEGEVEN OMSTANDIGHEDEN IS. PALRAM IS NIET VERANTWOORDELIJK VOOR ENIGE SCHADE OF LETSEL AAN DE KOPER, EEN ANDERE PERSOON OF ENIGE ANDERE ZAKEN ALS GEVOLG VAN ONDOELMATIG GEBRUIK, OPSLAG, INSTALLATIE, MONTAGE OF HET GEBRUIK VAN HET PRODUCT OF HET NIET VOLGEN VAN DE SCHRIFTELIJKE AANWIJZINGEN BETREFFENDE HET HANTEREN, OPSLAAN, INSTALLEREN, MONTEREN EN GEBRUIK VAN HET PRODUCT.
- 4.5 TENZIJ UITDRUKKELIJK ANDERS DOOR PALRAM AANGEGEVEN, IS HET PRODUCT ALLEEN BEDOELD VOOR NORMAAL HUISHOUDELIJK GEBRUIK. PALRAM IS NIET VERANTWOORDELIJK VOOR VERLIES, SCHADE, KOSTEN OF UITGAVEN ALS GEVOLG VAN HET GEBRUIK VAN HET PRODUCT VOOR ENIG DOEL DAT NIET IS AANBEVOLEN IN DE SCHRIFTELIJKE INSTRUCTIES OF DAT NIET IS TOEGESTAAN VANWEGE ENIGE TOEPASSELIJKE WETGEVING OF ANDERE GEBRUIKEN OP DE LOCATIE WAAR DE KOPER HET PRODUCT ZAL GEBRUIKEN.

NL

# Garantía limitada de 7 años de Palram

ES

Angaben zum Produkt: Protecciones de jardín y cubiertas para patios

Palram Applications (1995) Ltd (Número de la compañía: 512106824) cuya oficina registrada se encuentra en Teradion Industrial Park, M.P Misgav 20174, Israel ("Palram") garantiza que el Producto no tendrá defectos de material o de fabricación durante un periodo de siete años desde la fecha de compra original sujeto a las definiciones, términos y condiciones contenidos en esta garantía.

## 1. Condiciones

- 1.1 Esta garantía solo será válida si el Producto es instalado, limpiado, manipulado y mantenido de acuerdo a las recomendaciones por escrito de Palram.
- 1.2 Sin derogar lo anterior, los daños causados por el uso de la fuerza, manipulación incorrecta, uso inapropiado, uso o montaje o mantenimiento negligentes, accidentes, impacto de objetos extraños, vandalismo, contaminantes, alteración, pintado, conexión, pegado, sellado no de acuerdo al manual del usuario, o daños resultantes de la limpieza con detergentes incompatibles y desviaciones menores del Producto no están cubiertos por esta garantía.
- 1.3 Esta garantía no se aplica a daños resultantes de "fuerza mayor", que incluye entre otros, granizo, tormenta, tornado, huracán, ventisca, inundación, efectos del fuego.
- 1.4 Esta garantía es nula si los componentes o piezas estructurales utilizados no son compatibles con las recomendaciones escritas de Palram.
- 1.5 Esta garantía se aplica solamente al comprador normal del Producto. No se extiende a cualquier otro comprador o usuario del Producto (incluyendo, entre otros, cualquier persona que adquiera el Producto desde el comprador original).

## 2. Reclamaciones y notificaciones

- 2.1 Toda reclamación de la garantía debe ser notificada por escrito a Palram lo antes que sea posible razonablemente después de descubrir el Producto defectuoso, adjuntando el tique de venta original y esta garantía.
- 2.2 El reclamante debe permitir a Palram inspeccionar el Producto pertinente y el sitio de la instalación en sí mismo mientras el Producto está todavía en su posición original y no se ha retirado ni movido o alterado de ningún modo y/o devolver el Producto a Palram para evaluarlo.
- 2.3 Palram se reserva el derecho a investigar la causa de cualquier fallo de forma independiente.

## 3. Compensación

- 3.1 Si una reclamación bajo esta Garantía se notifica apropiadamente y es aprobada por Palram, el comprador, según considere Palram, puede o bien (a) comprar un Producto o pieza/s de recambio; o (b) recibir el reembolso del precio de compra del Producto o la pieza o piezas, todo de acuerdo al siguiente calendario:

El periodo tras la compra	Reembolso del Producto o Pieza /s	Recambio Según
Desde la fecha de compra hasta el final del primer año	Sin costes	100%
Fin del 1.er año hasta el final del 2.º año	El comprador pagará el 15% del precio original de compra	85%
Fin del 2.º año hasta el final del 3.er año	El comprador pagará el 30% del precio original de compra	70%
Fin del 3.er año hasta el final del 4.º año	El comprador pagará el 45% del precio original de compra	55%
Fin del 4.º año hasta el final del 5.º año	El comprador pagará el 60% del precio original de compra	40%
Fin del 5.º año hasta el final del 6.º año	El comprador pagará el 75% del precio original de compra	25%
Fin del 6.º año hasta el final del 7.º año	El comprador pagará el 85% del precio original de compra	15%

- 3.2 Para evitar cualquier duda, el cálculo de la determinación de la compensación por pieza/s defectuosas, según el calendario de arriba, se basará en la contribución de la pieza defectuosa al coste original del Producto. Palram se reserva el derecho de proporcionar sustituciones si el Producto o cualquier pieza del mismo no está disponible o es obsoleta.
- 3.3 Esta garantía no cubre ningún coste ni gasto de la retirada e instalación del Producto o impuestos o gastos de envío ni cualquier otra pérdida/s directa o indirecta que pueda resultar del defecto del Producto.

## 4. Condiciones generales y limitaciones

- 4.1 APARTE DE LO QUE SE HA AFIRMADO ESPECÍFICAMENTE EN ESTA GARANTÍA, TODAS LAS DEMÁS GARANTÍAS, TANTO EXPRESAS COMO IMPLÍCITAS, INCLUYENDO TODAS LAS GARANTÍAS IMPLÍCITAS DE COMERCIABILIDAD O IDONEIDAD PARA UN PROPÓSITO EN PARTICULAR SE EXCLUYEN EN LA EXTENSIÓN EN QUE LO PERMITA LA LEY.
- 4.2 EXCEPTO DONDE LO HAYAMOS DECLARADO ESPECÍFICAMENTE EN ESTA GARANTÍA, PALRAM NO SERÁ RESPONSABLE DE CUALQUIER PÉRDIDA O DAÑOS QUE SUFRA EL COMPRADOR DIRECTAMENTE, INDIRECTAMENTE O COMO CONSECUENCIA DE UTILIZAR EL PRODUCTO O EN CONEXIÓN DE CUALQUIER MODO CON EL MISMO.
- 4.3 SI SE PROHÍBE A PALRAM, BAJO CUALQUIER LEY APLICABLE, EXCLUIR LAS GARANTÍAS IMPLÍCITAS DE COMERCIABILIDAD O IDONEIDAD PARA UN PROPÓSITO EN PARTICULAR CON RELACIÓN AL PRODUCTO, LA DURACIÓN DE DICHAS GARANTÍAS IMPLÍCITAS SE LIMITA EXPRESAMENTE A LA DURACIÓN DE ESTA GARANTÍA, O SI ES MÁS TIEMPO, EL PERIODO MÁXIMO REQUERIDO POR LA LEY APLICABLE.
- 4.4 EL COMPRADOR ES RESPONSABLE ÚNICAMENTE DE DETERMINAR SI LA MANIPULACIÓN, ALMACENAMIENTO, MONTAJE, INSTALACIÓN O USO DEL PRODUCTO ES SEGURO Y APROPIADO EN CUALQUIER UBICACIÓN, PARA CUALQUIER APLICACIÓN DADA O EN CUALQUIER CIRCUNSTANCIA DADA. PALRAM NO ES RESPONSABLE POR CUALQUIER DAÑO O LESIÓN DEL COMPRADOR, CUALQUIER OTRA PERSONA O CUALQUIER PROPIEDAD QUE RESULTE DE LA MANIPULACIÓN, ALMACENAMIENTO, INSTALACIÓN, MONTAJE O USO INADECUADOS DEL PRODUCTO O NO SEGUIR LAS INSTRUCCIONES ESCRITAS ACERCA DE LA MANIPULACIÓN, ALMACENAMIENTO, INSTALACIÓN, MONTAJE Y USO DEL PRODUCTO.
- 4.5 A MENOS QUE SE INDIQUE EXPRESAMENTE LO CONTRARIO POR PALRAM, EL PRODUCTO ESTÁ PREVISTO SOLO PARA USO RESIDENCIAL NORMAL. PALRAM NO ES RESPONSABLE POR NINGUNA PÉRDIDA, DAÑO, COSTE O GASTO RESULTANTE DE CUALQUIER USO DEL PRODUCTO PARA CUALQUIER PROPÓSITO QUE NO ESTÉ RECOMENDADO POR LAS INSTRUCCIONES ESCRITAS O QUE NO ESTÉ PERMITIDO POR CUALQUIER LEGISLACIÓN APLICABLE U OTROS CÓDIGOS EN VIGOR EN LA UBICACIÓN DONDE USARÁ EL PRODUCTO EL COMPRADOR.