

REV	CHANGE DESCRIPTION	ZONE	ECN #	DATE	APV BY
01	DESIGN RELEASE		ECN-HFE010521	12/14/18 JACE	01/17/19 PZG
02	ADD #24		ECN-HFE010828	01/28/19 KNIGHT	01/30/19 BRIAN

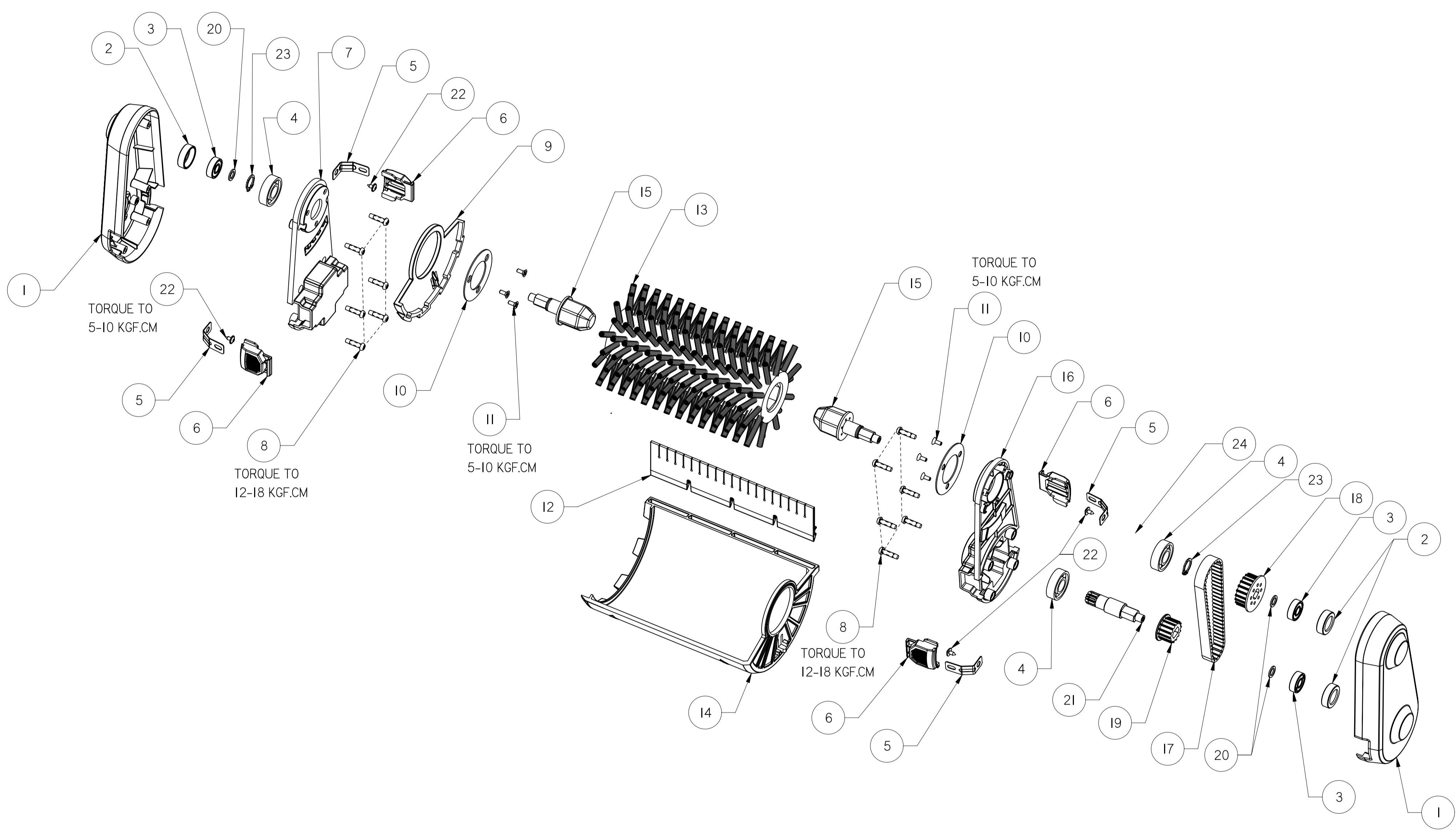

24	902167003	0.1G	ADHESIVE, LOCTITE 326 \ 038211		
23	673897001	2	STAMPINGMETALITHE E- RING FOR DRIVEN WHEEL	CL00040576	
22	662878001	4	ST SCREW,STEEL CH M3.0 PWH PHILLIPS B \ L=6.5MM	CL00041919	
21	622423001	1	MACHINING SHAFT\ FOR DRIVING WHEEL	CL00034810	
20	635915001	3	FLAT WASHER,STEEL CH 7.3X11X1.0 mm \ ZN-PLATED	CL00036684	
19	613929001	1	POWDER METAL DRIVING WHEEL\FOR LEFT ROLLER	CL00036608	
18	613930001	1	POWDER METAL DRIVEN WHEEL\FOR LEFT ROLLER B	CL00034809	
17	564959001	1	BELT 5M-290-10	CL00036079	
16	536764001	1	PLASTIC,COVER \FOR LEFT MOUNTING ASSY \ROLLER	CL00037026	
15	536766001	2	PLASTIC,THE LEFT CONNETOR OF ROLLER BRUSH\INA	CL00036640	
14	536769001	1	PLASTIC,THE ROLLER BRUSH COVER\090419\BLACK\IF	CL00034799	
13	314190001	1	PLASTIC,ROLLER BRUSH\090419001	CL00034802	
12	564962001	1	NBR, THE SPLASH GUARD FOR THE ROLLER BRUSH C	CL00034794	
11	660204013	6	SCREW	66020401300099	
10	673898001	2	STAMPING\METAL\,THE WASHER FOR ROLLER BRUSH	CL00034804	
9	536770001	1	PLASTIC,THE RIGHT BOARD OF ROLLER BRUSH COVER	CL00034801	
8	660208052	12	ST SCREW M4x1.41 PH PHILIPS B	66020805200099	
7	536764002	1	PLASTIC,COVER OF RIGHT ROLLER BRUSH ATTACHE	CL00038100	
6	536696001	4	PLASTIC,PUSH BUTTON\PA6-GF30%RG301 FLEXBONE	CL00035314	
5	635893001	4	STAMPING SPRING PLATE\FOR BUTTON	CL00035315	
4	690697001	3	BALL BEARING, ID 12X28X8	69069700100099	
3	682352001	3	BALL BEARING,KEJIE 607 2Z ID7XOD19XW6MM \ FOR O	CL00041886	
2	536763001	3	BEARING \PAD\FOR LEFT ROLLER BRUSH ATTACHE	CL00036638	
1	536765001	2	PLASTIC,BASE\ FOR LEFT MOUNTING ASSY \ROLLER B	CL00036144	
ITEM	CN ORA PN	QTY	PART NAME	PLM ID	REMARK

NOTES: (I)

(M) 1. REFER TO COMPONENT DRAWING FOR INSPECTION CRITERIA

2. SEE QUALITY ASSURANCE FOR ADDRESSING CRITICAL AND MAJOR DIMENSIONS

TOTAL (C) THIS PAGE = 0

TOTAL (M) THIS PAGE = 1

Techtronic Industries Co. Ltd.		METRIC UNLESS OTHERWISE SPECIFIED DIMENSIONS ARE IN MILLIMETERS		3RD ANGLE PROJECTION	
CONFIDENTIAL		DIMENSION & TOLERANCE PER ASME Y14.5 - 2009		UNSPECIFIED DIMENSIONS REFERENCE CAD MODEL	
THIS DRAWING IN DESIGN AND DETAIL IS THE PROPERTY OF TECHTRONIC INDUSTRIES COMPANY LIMITED. ALL RIGHTS OF DESIGN OR INVENTION ARE RESERVED.		WEIGHT & TOLERANCE		CN ORA PN 000997209	
COLOR COLOR NAME, COLOR CHIP #		DRAWN BY JACE		SC SAP PN	
PART & PROCESS MUST COMPLY WITH THE COMPANY REQUIREMENTS OF HAZARDOUS SUBSTANCE FREE.		BU OP		MODEL NO.	
CAD TOOL NX		SCALE 1:1		SHEET 1 OF 3	
SIZE AI		PLM ID		REV 02	
CL00038406		PLM ID		REV 02	

REV	CHANGE DESCRIPTION	ZONE	ECN #	DATE	APV BY
01	DESIGN RELEASE		ECN-HFE010521	12/14/18 JACE	01/17/19 PZG
02	ADD #24		ECN-HFE010828	01/28/19 KNIGHT	01/30/19 BRIAN

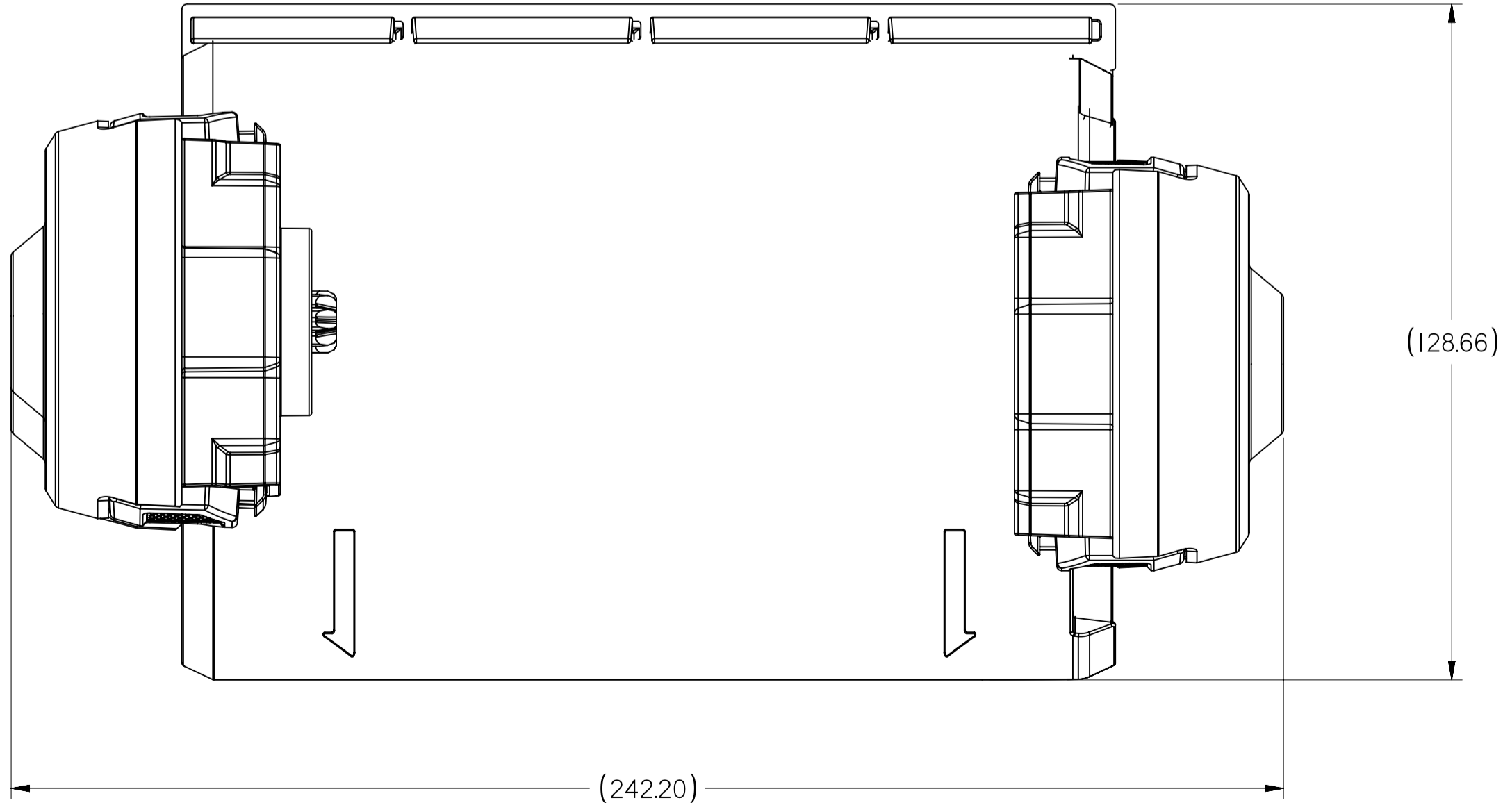
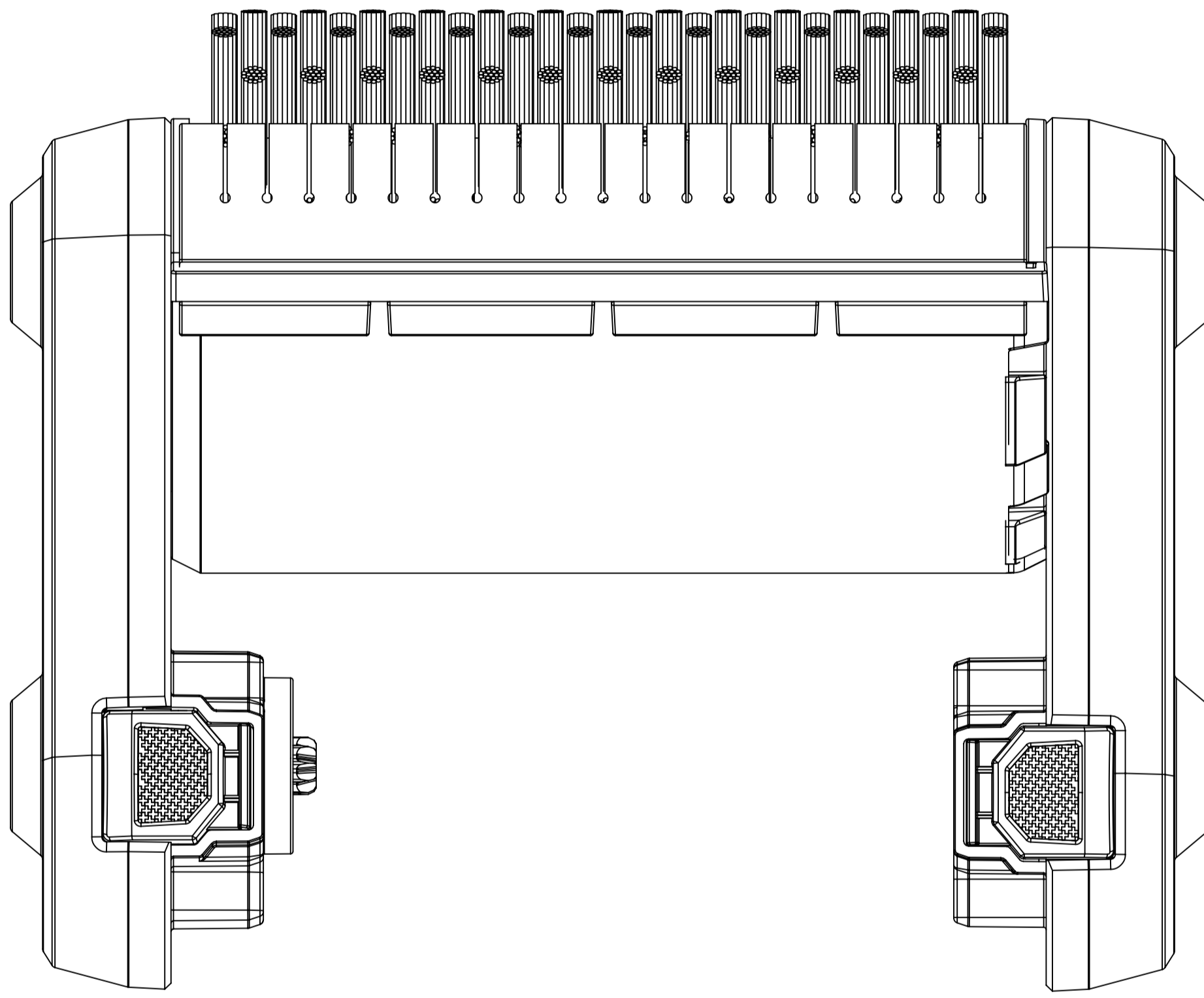
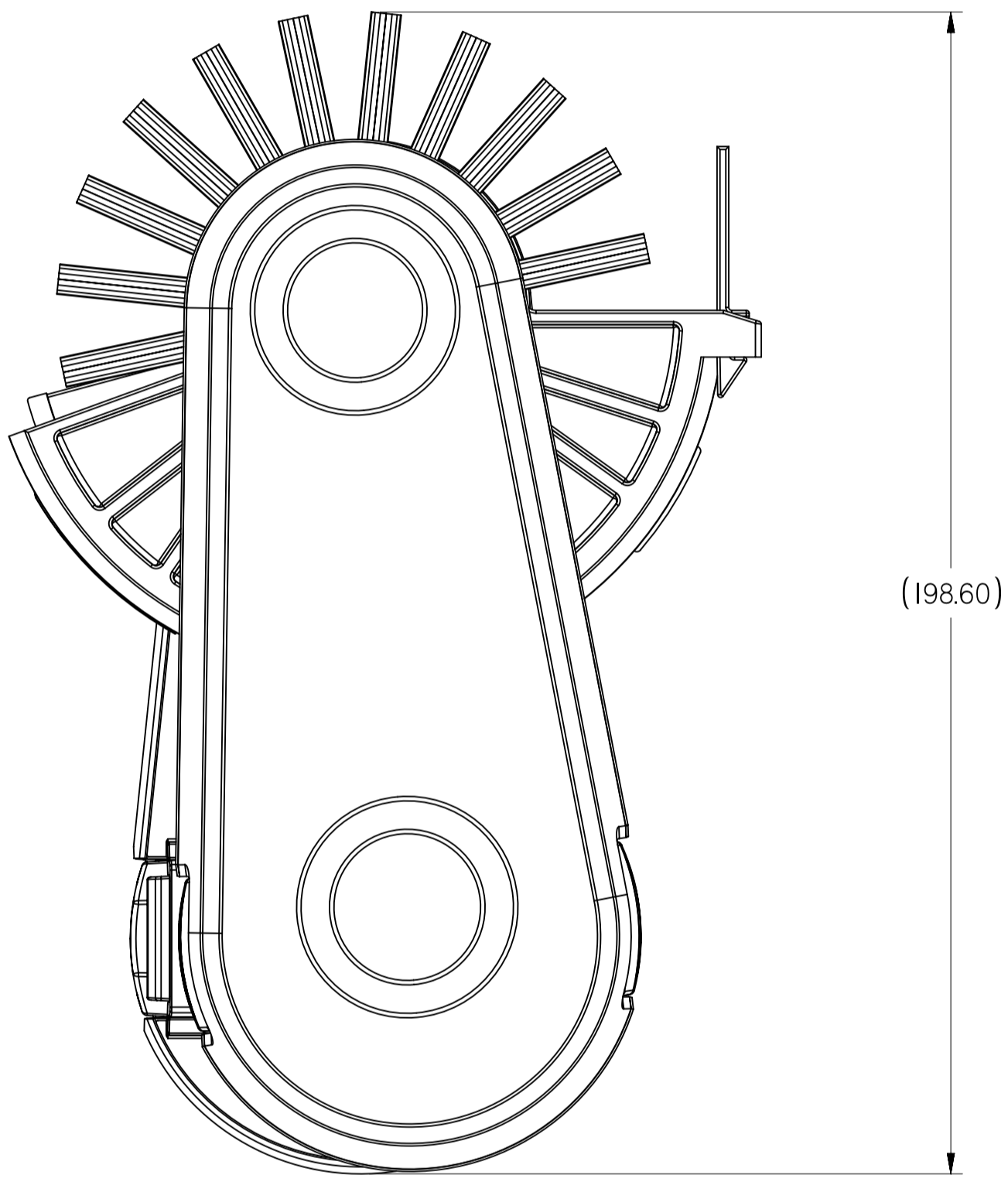
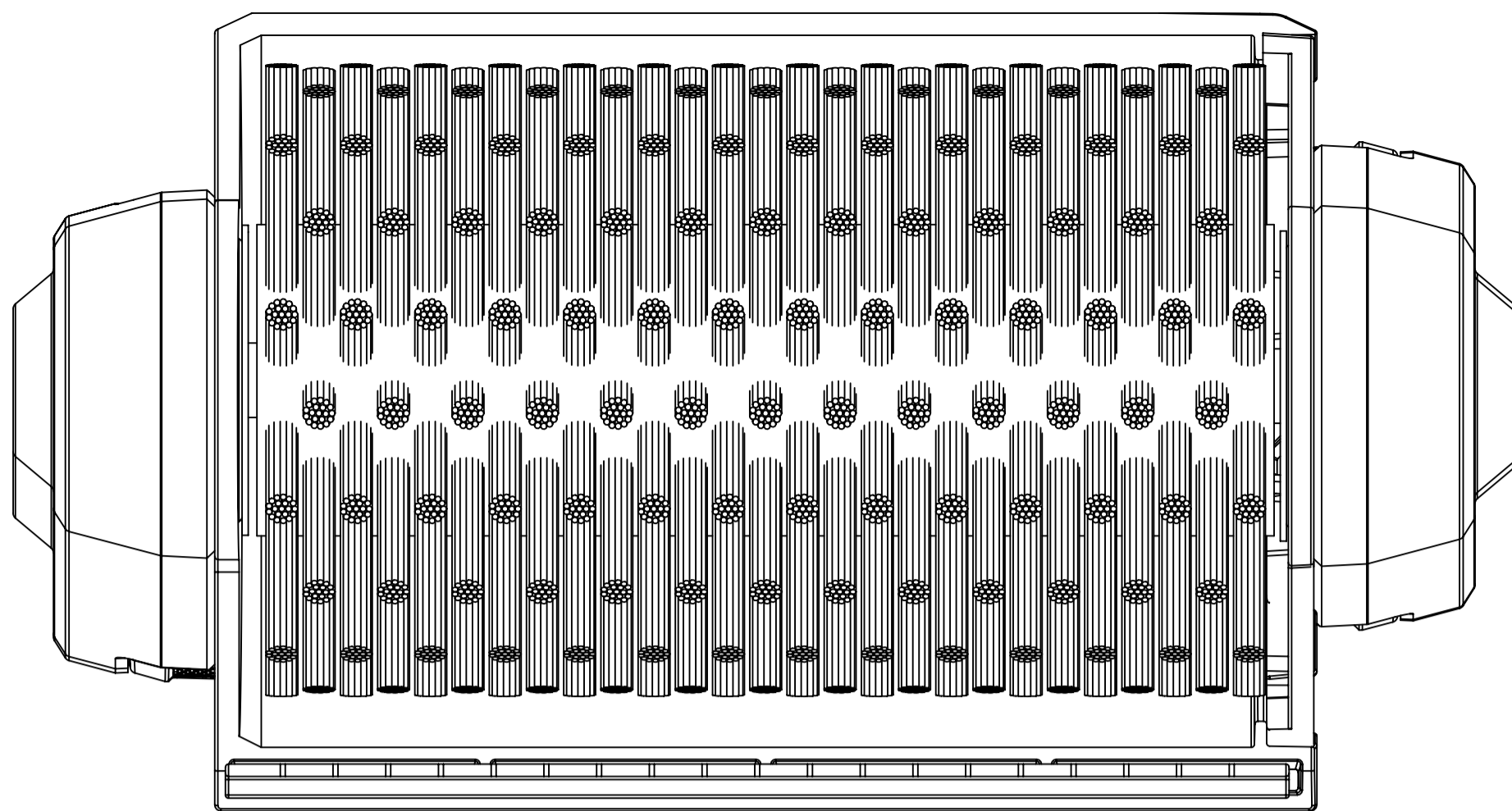

NOTES: (I)

(M) 1. REFER TO COMPONENT DRAWING FOR INSPECTION CRITERIA

2. SEE QUALITY ASSURANCE FOR ADDRESSING CRITICAL AND MAJOR DIMENSIONS

TOTAL (C) THIS PAGE = 0

TOTAL (M) THIS PAGE = 1

Techtronic Industries Co. Ltd.		METRIC	UNLESS OTHERWISE SPECIFIED DIMENSIONS ARE IN MILLIMETERS	3RD ANGLE PROJECTION
CONFIDENTIAL		PART & PROCESS MUST COMPLY WITH THE COMPANY REQUIREMENTS OF HAZARDOUS SUBSTANCE FREE.		ON DRA PIN
THIS DRAWING IN DESIGN AND DETAIL IS THE PROPERTY OF TECHTRONIC INDUSTRIES COMPANY LIMITED. ALL RIGHTS OF DESIGN OR INVENTION ARE RESERVED.		DIMENSION & TOLERANCE PER ASME Y14.5 - 2009	UNSPECIFIED DIMENSIONS REFERENCE CAD MODEL	000997209
WEIGHT & TOLERANCE		DRAWN BY	JACE	
COLOR NAME, COLOR CHIP #		BU	OP	
CAD TOOL		SCALE	SHEET	SIZE
NX		1:1	3 OF 3	AI
MODEL NO.		REV	CL00038406 02	