 International Purchases	Bill of Material		Revision date
	SUNBED NATERIAL AQUILA FIX ALU PADDED TEXTYLEN		Prepared by Letright
P 2/6	COMPOSITION		FOR Adeo
	International Quality Dept.		

PRODUCT COMPOSITION DETAILS						
Code	Type of elements	QTY	Material		Covering / veneer / finishing	
			Type : for wooden parts don't forget to fill in the sheet 4	Characteristics / dimensions		
1	BACK CLOTH	1		TEXTILENE 2X1		SEWING
2	SEAT CLOTH	1		TEXTILENE 2X1		SEWING
3	BACK & SEAT INSIDE FILLING	2		FAST DRY FOAM.10MM THICKNESS		PADDED
4	SEAT FRAME TUBE	2		ALUMINUM		POWDER COATING
5	FOOT TUBE	4		ALUMINUM		POWDER COATING
6	FRONT & BACK HORIZONTAL TUBE	2		ALUMINUM		POWDER COATING
7	SEAT& BACK SUPPORTING TUBE	5		ALUMINUM		POWDER COATING
8	BACK CLOTH WEARING TUBE	2		ALUMINUM		POWDER COATING
9	SEAT CLOTH WEARING TUBE	2		ALUMINUM		POWDER COATING
10	SWING TUBE	1		ALUMINUM		POWDER COATING
11	PLASTIC RACK	2		PP		DARK GREYLIGHT GREY/BROWN
12	SWING TUBE SUPPORTING TUBE	1		ALUMINUM		POWDER COATING
13	SCREW 1	2		STEEL		GALVANIZED
14	PLASTIC CAP	2		PP		DARK GREYLIGHT GREY/BROWN
15	PLASTIC CAP WITH WHEELS	2		PA		DARK GREYLIGHT GREY/BROWN
16	PLASTIC CAP	8		PP		DARK GREYLIGHT GREY/BROWN
17	SCREW 2	22		STAINLESS STEEL		STAINLESS STEEL COLOR

Exploded view / Numbered view (or photo)

Maxi loads on the Tops, shelves and extractable

TECHNICAL DRAWING

E1784
UNIT: MM

TOLERANCE: +/- 2%
SIZE: W640/D2200/H875
MATERIAL: ALUMINUM W/POWDER COATING /SLING

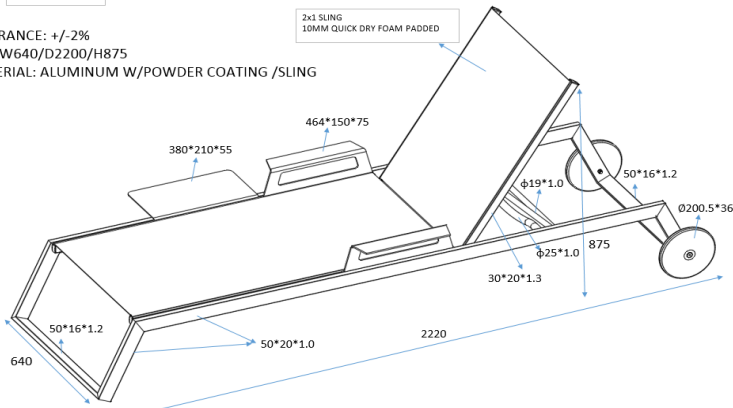

EXPLODED DRAWING

