

FAR TOOLS®



PM 6AB

Professional Machine

FR *Visseuse à plaque de plâtre (Notice originale)*

EN *Plasterboard screw inserter (Original manual translation)*

DE *Gipsplattenschrauber (Übersetzung aus dem Original-Anleitung)*

ES *Atornillador para placas de yeso (Traducción del manual de instrucciones originale)*

IT *Avvitatrice per cartongesso (Traduzione dell'avvertenza originale)*

PT *Aparafusadora para gesso (Tradução do livro de instruções original)*

NL *Schroevendraaier voor gipsplaat (Vertaling van de originele instructies)*

EL *Μηχανή βιδώματος για πλάκες γύψου (Μετάφραση από τις πρωτότυπες οδηγίες)*

PL *Wkretarka do płyt kartonowo-gipsowych (Tłumaczenie z oryginalnej instrukcji)*

FI *Laastiin ruuvaava porakone (Käännös alkuperäisestä ohjeet)*

SV *Skruvdragare för gipsskivor (Översättning från originalinstruktioner)*

BU *Skruemaskine til gipsplader (Перевод на оригиналната инструкция)*

DA *Maskine til at sætte skruer i gipsplader (Oversættelse fra oprindelige brugsanvisning)*

RO *Mașină de înșurubat pentru gips-carton (Traducere din instrucțiunile originale)*

RU *Шуруповерт для гипсокартона (Перевод с оригинальной инструкции)*

TU *Elektri 'kli` vi` dalama maki` nasi (Orijinal talimatlar çeviri)*

CS *Uzavíračka pro sádku (Překlad z originálního návodu)*

SK *Uzatvárač na sadru (Preklad z originálneho návodu)*

HE *תוירוקמ תוארומה סוגרת) סימלה הגרמ*

AR *(فيصل ال تا ميل عل ن م ق م ج ر ت ل ا) ي ا ب ر ه ك ل ف م*

HU *Gipszkarton csavarozó (Fordítás az eredeti utasítások)*

SL *Vijačnik za mavčne plošče (Prevod iz izvirnih navodil)*

ET *Kruvikeeraja kipsmaterjalidele (Tõlge originaal juhiseid)*

LV *Apmetuma plākšņu skrūvgriezis (Tulkojumā no instrukcijas oriģinālvalodā)*

LT *Gipsinis tvirtinimo aparatas (Vertimas iš originalių instrukcijas)*



© FAR GROUP EUROPE

115009-2-E-20171212

www.fartools.com

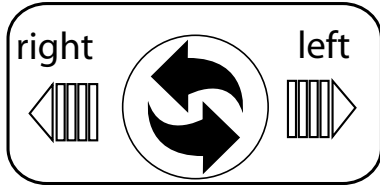

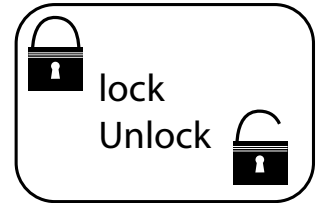

on
off

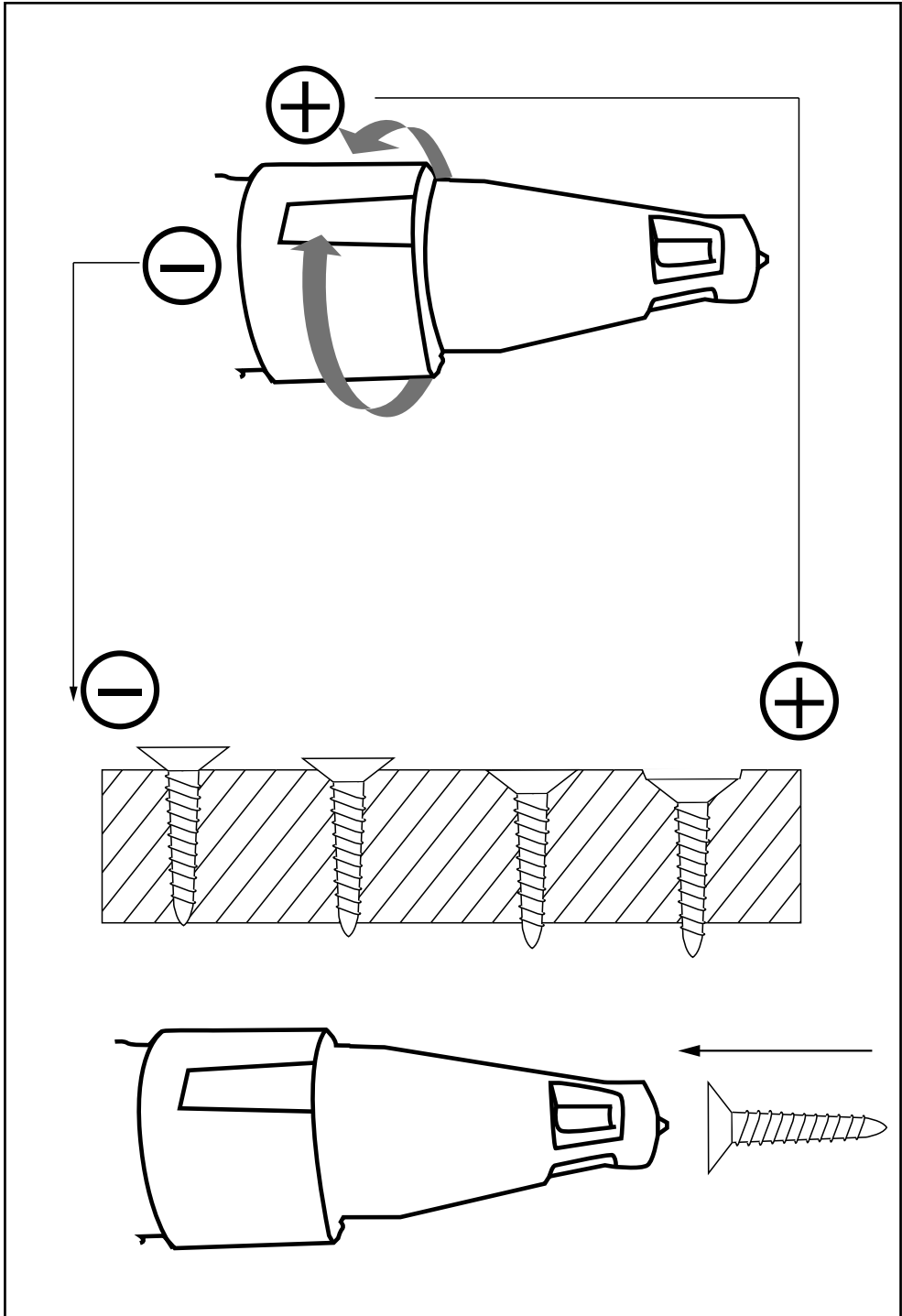







	<p>Tension et fréquence assignée: Nominal frequency and power: Spannung und Frequenz: Tensión y frecuencia fijada: Tensione e frequenza assegnata: Tensão e frequência fixa: Aangewezen spanning en frequentie: Ονομαστική τάση και συχνότητα: Napięcie i częstotliwość przydzielona: Jännite ja määrätty taajuus: Angiven spänning och frekvens: Anført spænding og frekvens: Tensiune și frecvență de lucru:</p>	<p>Заданное напряжение и частота: Tahsis gerilimi ve frekansı: Stanovené napětí a frekvence: Stanovené napätie a frekvencia: מחמת ותדר מוקצב. الغسلطة والذبذبة المبرمجة. Névfleges feszültség és frekvencia: Napetost in določena frekvenca: Консумирано напрежение и честота : Määratud pinge ja sagedus Nustatyta įtampa ir dažnis Noteiktais spriegums un frekvence.</p>	230 V ~ 50 Hz
---	--	--	----------------------

	<p>Puissance assignée: Nominal power: Leerlaufdrehzahl: Potencia fijada: Potenza assegnata: Potência assinada: Onbelast toerental: Ονομαστική ισχύς : Prędkość na biegu jałowym: Teho: Angiven effekt: Anført styrke: Putere de lucru:</p>	<p>Заданная мощность: Tahsis edilen güç: Stanovený příkon: Predpísaný výkon: כוח מוקצב. القدرة المبرمجة. Névfleges teljesítmény : Določena jakost: Консумирана мощност: Määratud võimsus. Nustatyta galia Noteiktā jauda</p>	620 W
---	--	---	--------------

	<p>Vitesse à vide: No-load speed: Drehzahl unbelastet: Velocidad vacía: Velocità a vuoto: Velocidade no vácuo: Leerlaufdrehzahl: Ταχύτητα στο κενό: Prędkość bez obciążenia: Tyhjäkäyntinopeus Tomgångshastighet: Hastighed i ubelastet tilstand: Viteza în gol:</p>	<p>Скорость вращения на холостом ходу: Boşalma hızı: Rychlost naprázdno: Rýchlosť pri chode naprázdno: מהירות ריק. السرعة على الفارغ. Üres sebesség: Prosti tek: Скорост на празни обороти: Kiirus tühikäigul Tuščio prietaiso greitis Tukšgaitas ātrums</p>	0-4000 min⁻¹
--	--	---	--------------------------------

	<p>Poids : Weight : Gewicht : Peso : Peso : Peso : Gewicht : Βάρος : Masa : Paino : Vikt : Vægt : Greutate :</p>	<p>Вес : Ağırlık : Hmotnost : Hmotnosť : משקל الوزن. Súly : Teža : Терло : Raskus Svoris Svars</p>	1,65 kg
---	--	---	----------------





 L_{pA}	Niveau de pression acoustique : Acoustic pressure level : Schalldruckpegel : Nivel de presión acústica : Livello di pressione acustica : Nível de pressão acústica : Niveau akoestische druk : Στ'αΘμη Θορ'ύβου ≅ Poziom mocy akustycznej : Käytä kuulosuojaimia: Ljudtrycksnivå : Lydtryk : Nível presiune acustică :	Уровень акустического давления. : Akustik basınç seviyesi : Hladina akustického tlaku : Hladina akustického tlaku : רמת לחץ אקוסטי. مستوى الضغط السمعي. A hangnyomás szintje : Nivo akustičnega pritiska: Равнище на акустично налягане : Helirõhu nivoo Akustinio spaudimo lygis Akustiskā spiediena līmenis	85 dB (A)
	Niveau de puissance acoustique : Acoustic power level : Schalleistungspegel : Nivel de potencia acústica : Livello di potenza acustica: Nivel de potência acústica: Niveau akoestisch vermogen : Στ'αΘμη Ονομαστική Θορ'ύβου ≅ Poziom mocy akustycznej : Käytä suojalaseja : Ljudstyrkenivå : Lydstyrke : Nível putere acustică :	уровень мощности звука : Akustik basınç seviyesi : Hladina zvukového výkonu: Hladina zvukového výkonu: רמת כוח אקוסטי. مستوى الصوتي. a hangnyomás szintje : Nivo akustične jakosti : Равнище на вибрации : Helivõimsuse nivoo Triukšmo lygis Akustiskās jaudas līmenis	

NIVEAU SONORE D'EMISSION:

A VIDE

Pression acoustique LpA poste opérateur
Incertitude

85 dB
3

Puissance acoustique LWA
Incertitude

96 dB
3

Valeurs déterminées suivant le code d'essai de l'annexe B de la norme EN 61029-1 avec emploi des normes de base ISO 11201 et ISO 3744.

Les niveaux de pression acoustique obtenus in situ dépendent:

- Des niveaux réels de la machine considérées, en prenant en compte les incertitudes déclarées;
- Du local et de l'installation de la machine. Préférez une pièce dont l'acoustique est plus feutrée. Evitez les pièces vide à grande résonance. Placez vous auprès d'une fenêtre le cas échéant.
- Des outils montés, des pièces travaillées, des réglages choisis,...

 L_{wA}	Niveau de vibration : Hand/arm vibration level : Vibrationspegel Hand/Arm : Nivel de vibración mano/brazo : Livello di vibrazione mano/braccio : Nível de vibraçãõ mão/braço : Trillingsniveau hand/arm : Στ'αΘμη κρα'οασμών : Poziom vibracji rżka/ramiż : Tärinätaso: Vibrationsnivå hand/arm : Vibrationsniveau : Nivel vibrații :	Уровень вибрации : Titreşim seviyesi : Úroveň vibrací : Hladina vibrácií : רמת תנודות مستوى الارتجاج. Vibrációs szint : Nivo vibracij : Равнище : Vibrācijas līmenis. Vibrācijas lygis Vibratsiooni nivo	0,79 m/s²
	Niveau de vibration : Hand/arm vibration level : Vibrationspegel Hand/Arm : Nivel de vibración mano/brazo : Livello di vibrazione mano/braccio : Nível de vibraçãõ mão/braço : Trillingsniveau hand/arm : Στ'αΘμη κρα'οασμών : Poziom vibracji rżka/ramiż : Tärinätaso: Vibrationsnivå hand/arm : Vibrationsniveau : Nivel vibrații :	Уровень вибрации : Titreşim seviyesi : Úroveň vibrací : Hladina vibrácií : רמת תנודות مستوى الارتجاج. Vibrációs szint : Nivo vibracij : Равнище : Vibrācijas līmenis. Vibrācijas lygis Vibratsiooni nivo	

VIBRATIONS:

Total des valeurs de vibration (somme vectorielle des trois directions) déterminée selon EN 60745:

a 0,79 m/s²
Incertitude K_w 1,5 m/s²

L'amplitude d'oscillation peut être utilisée comme valeur de comparaison d'outils électroportatifs.

Attention: Si l'outil électroportatif est utilisé pour d'autres applications, avec d'autres outils de travail, l'amplitude d'oscillation peut être différente.







	<p>Porter des lunettes de sécurité : Porter un masque anti-poussière: Porter une protection auditive:</p> <p>Wear protective eyewear : Wear a dust mask : Wear hearing protective equipment:</p> <p>Schutzbrille tragen : Staubschutzmaske tragen : Gehörschutz tragen:</p> <p>Llevar puestas gafas protectoras : Llevar puesta una careta de protección contra el polvo : Llevar puesta una protección auditiva:</p> <p>Portare de gli occhiali di sicurezza : Indossare una mascherina anti-polvere : Portare una protezione uditiva:</p> <p>Utilizar óculos de segurança : Utilizar uma máscara anti-poeira : Utilizar uma protecção auditiva:</p> <p>Draag een veiligheidsbril : Draag een stofmasker : Draag gehoorbeschermers:</p> <p>Φορέστε Προστατευτικά γυαλιά : χρήση προστατευτική μάσκα : Φορέστε Προστατευτικά ακουστικά</p> <p>Zakładać okulary ochronne : Zakładać maskę przeciwpyłową Zakładać słuchawki ochronne</p> <p>Käytä suojalaseja : Käytä pölysuojust : Käytä kuulosuojaimia:</p> <p>Använd skyddsglasögon : Bär mask mot damm : Bär hörselskydd:</p> <p>Der skal benyttes sikkerhedsbriller : Der skal benyttes beskyttelsesmaske mod støv: Der skal benyttes høreværn:</p> <p>Purtați ochelari de protecție : Purtați mască anti-praf : Purtați căști de protecție auz:</p>	<p>Наденьте защитные очки : Наденьте респиратор : наденьте средства звуковой защиты:</p> <p>Güvenlik gözlükleri takın : Toza karşı maske takın : İşitsel koruma aleti takın:</p> <p>Požívajte bezpečnostní brýle : Používejte masku proti prachu : Používejte ochranu sluchu:</p> <p>Noste ochranné okuliare : Noste ochrannú masku proti prachu : Noste ochranné slúchadlá:</p> <p>תוחיטב יפקשמ ביכרהל אן קבא דגג הכסמ שובחל אן יש ל הרכיב הגנת שמיעה</p> <p>حمل نظارات وقاية لبس قناع مضاد للغبار لبس حوذة ضوضاء الضجيج</p> <p>Viseljen védőszemüveget : Viseljen porvédő maszkot Viseljen fülvédőt</p> <p>Nositi zaščitna očala : Nositi zaščitno masko proti prahu: Nositi zašitno ušes:</p> <p>Да се използват защитни очила : Да се използва защитна маска : Да се използва слухови защитни средства:</p> <p>Kandke kaitseprille Kandke tolmumaski. Kandke kõrvakaitset</p> <p>Nešioti apsauginius akinius Dėvėti respiratorių Nešioti apsaugą nuo triukšmo</p> <p>Valkät aizsargbrilles Valkät aizsarg masku pret puteklēm valkät dzirdes aizsarglīdzekli</p>	X
---	---	--	---

	<p>Porter des gants : Use rubber gloves : Schutzhandschuhe tragen : Llevar guantes de protección : Indossare i guanti di protezione : Utilizar luvas de protecção : Draag veiligheidshandschoenen : χρήση προστατευτικών γαντιών : Używać rękawic ochronnych : Käytä suojakäsineitä : Använd skyddshandskar : Der skal benyttes handsker : Purtați mănuși :</p>	<p>Наденьте перчатки :</p> <p>Eldiven takın : Noste rukavice : Noste rukavice : תופכ שובלל אן لبس قفازات. Viseljen kesztyű t Nositi rokavice: a se използват предпазни ръкавици : Kandke kindaid Müvėti pirštines Valkät cimdus</p>	X
---	---	---	---





	<p>Conformité européenne Conforms to EC standards : CE-Konformität : Cumples con las directivas CE : Conforme alle norme CE : Conforme às normas CE : Voldoet aan de EG-normen : Σ'υμφωνα με τα πρότυπα Zgodność z normami CE : EU-standardien mukainen : EU-standardien mukainen : Overholder EU standarderne : Conform cu normele europene:</p>	<p>соответствие европейским стандартам: Avrupa uygunluk : evropská shoda : európska dohoda : התאמה לתקנים האירופיים مطابق للمواصفات الأوروبية. evropska ustreznost : európai megfeleléesség : Съответствие с европейските норми : Euroopa Liidu vastavusmärk Euroopiņu normų atitikima Atbilstība Eiropas standartiem</p>	X
---	---	---	---

	<p>Lire les instructions avant usage : Read the instructions before use : Vor Einsatz des Geräts Anweisung lesen : Léase las instrucciones antes de usar : Leggere le istruzioni prima dell'uso : Ler as instruções antes da utilização : Lees voor het gebruik de instructies : Διαβάστε τις οδηγίες χρήσης : Zapoznać się z instrukcją przed użyciem : Lue ohjeet ennen käyttöä : Läs anvisningarna före användning : læs instruktionerne før brug Înainte de utilizare, citiți instrucțiunile :</p>	<p>Внимательно прочитайте следующие инструкции : Kullanmadan talimatları okuyunuz : Pozorně si přečtěte následující pokyny : Pred použitím si prečítajte pokyny : זרם חילופי اقرأ التعليمات قبل الاستخدام. használat előtt olvassuk el az utasítást : Pred uporabo preberite ustrezna navodila : Прочетете указанията за употреба : Enne kasutamist lugege instruksiooni Prieš naudojimą perskaityti instrukciją izlasīt instrukcijas pirms lietošanas</p>	X
---	--	--	---

	<p>Danger : Danger : Gefahr : Peligro : Pericolo : Perigo : Gevaar : Κινδύος : Niebezpieczeństwo : Vaara : Fara : Fare : Pericol :</p>	<p>Опасно : Tehlike : Nebezpečí : Nebezpečnost : סכנה. خطر. Veszély : Nevarnost : Опасност : Oht Pavojus Bistamība</p>	X
---	--	--	---

	<p>Classe d'isolement : 2 Insulation class : 2 Isolierung klasse : 2 Aislamiento clase :2 Isolamento classe :2 Isolamento classe :2 Isolatie Klasse : 2 Εργαλειο τάξηζ : 2 Izolacja Klazy :2 Eristysluokka :2 Isolering Klass :2 Isoleringsklasse 2 Clasă izolație :2</p>	<p>Класс изоляции 2 : Yalıtım derecesi :2 Třída izolace :2 Izolačný systém 2 סוג בידוד 2. فسیة ال عزل 2. Szigetelési osztály :2 Razred izolacije :2 Инструмент Клас :2 Isolatsiooniklass 2 Izolācijas rūšis 2 Izolācijas klase 2</p>	X
---	---	--	---

<p>IP 20</p>		X
---------------------	--	---





	<p>Soumis à recyclage Subjected to recycling Sujeto a reciclaje Sottoposti a riciclaggio Sujeitos à reciclagem Não deite no lixo : Niet wegwerpen : Μην την πετάτε : Nie wyrzucas : Älä heitä pois luontoon : Batteriet får inte kastas : Bortkast det ikke: Nu le auncati :</p>	<p>Не выбрасывайте в мусорный ящик Atmayiniz : Nevyhadzujte je do bežného odpadu : Neodhadzovat : אין לזרוק סוללות فلا ترمدها هكذا في القمامة. ne mečite! Ne odvržite ga/jih vstran : Не го изхвърляйте : Ärge visake seda minema : Nemétykíte : Nemest :</p>	X
---	--	---	---

FR-Recyclage des déchets:

Les outils, accessoires et leur emballages doivent suivre une voie de recyclage adaptée. Conformément aux directives Européenne 2012/19/UE et 2006/66/CE, les composants d'un produit doivent être séparés, collectés, recyclés ou éliminés en conformité avec les réglementations environnementales en vigueur. Les appareils, batteries, piles, huiles, emballages devront être déposés dans les systèmes d'élimination des déchets spéciaux tels que déchetteries. Renseignez vous auprès de votre commune pour connaître l'organisme le plus proche à même de retraiter ou de collecter ces déchets.

NL-Waste Recycling:

Gereedschappen, accessoires en de verpakking moet een recycling traject aangepast volgen. Overeenstemming met de Europese Richtlijnen 2012/19/UE en 2006/66/CE, de onderdelen van een product moet worden gescheiden, verzameld, gerecycleerd of verwijderd in overeenstemming met de milieuvorschriften. Apparaten, batterijen, olie, moet de verpakking worden gedeponerd in de verwijdering van gevaarlijke afvalstoffen, zoals afvalverwerking systemen. Informeer bij uw gemeente naar de dichtstbijzijnde staat om opnieuw te verwerken of te verzamelen het afval lichaam te vinden.

EN-Waste recycling:

The tools, accessories and their packaging must use an appropriate recycling channel. In compliance with European Directives 2012/19/UE and 2006/66/CE, a product's components must be separated, collected, recycled or eliminated in accordance with the environmental regulations in force. The appliance, batteries, oils and packaging must be deposited in the special waste elimination systems such as the waste collection centres. Ask your commune for information on the nearest organisation in a position to reprocess or collect this waste

ES-Reciclado de los residuos:

Las herramientas, los accesorios y los envases tienen que seguir la vía de reciclaje adecuada. En virtud de las directivas europeas 2012/19/UE y 2006/66/CE, los componentes de un producto deben separarse, recogerse, reciclarse o eliminarse de acuerdo con las reglamentaciones medioambientales vigentes. Los aparatos, baterías, pilas, aceites, envases deberán llevarse a los centros de eliminación de residuos especiales tales como los ecoparques. Pedir información al municipio par conocer el centro más cercano apto para reciclar o recoger dichos residuos.

IT-Riciclaggio dei rifiuti:

Gli apparecchi, i loro accessori ed imballaggi devono essere sottoposti ad un processo di riciclaggio appropriato. In conformità con le direttive europee 2012/19/UE e 2006/66/CE, i componenti di un prodotto devono essere separati, raccolti, riciclati o smaltiti in conformità con le normative ambientali in vigore. Gli apparecchi, le batterie, le pile, gli oli, gli imballaggi dovranno essere conferiti nei sistemi di smaltimento dei rifiuti speciali come le isole ecologiche. Informarsi presso il proprio comune per sapere qual è l'ente più vicino in grado di fare il trattamento o la raccolta differenziata di questi rifiuti

PT-Reciclagem do lixo:

As ferramentas, acessórios e suas embalagens devem seguir um canal de reciclagem adaptado. Conformemente às diretivas europeias 2012/19/UE e 2006/66/CE, os componentes de um produto devem ser separados, recolhidos, reciclados ou eliminados de acordo com as regulamentações ambientais em vigor. Os aparelhos, baterias, pilhas, óleos e embalagens deverão ser depositados nos sistemas de eliminação de detritos especiais, tais como unidades de triagem de detritos. Informar-se junto ao seu concelho municipal para conhecer o órgão mais próximo habilitado a evacuar ou recolher estes detritos.

	<p>Recyclable, soumis au tri sélectif Recyclable, subject to recycling Recyclingfähige, unterliegen Recycling Reciclables, sujetos a reciclaje Riciclabili, soggetti a riciclaggio Recicláveis, sujeito à reciclagem Recycleerbare, onderworpen aan recycling Ανακυκλώσιμες συσκευασίες που υπόκεινται σε κύκλωση Opakowanie nadaje się do recyklingu podlegają recyklingu Kierrätettävien pakkausten kohteena kierrätys Återvinningsbara förpackningar omfattas återvinning Рециклиращи се опаковки подлежат на рециклиране Genavendelig underlagt genbrug</p>	<p>Reciclabile sub rezerva reciclare Повторно опаковка подлежит вторичной переработке Gerí dönüştürüm Geri dönüştürülebilir ambalaj konusu Recyklovateľné podléhajúce recyklaci Recyklovateľné podliehajúce recyklácii החומר והחמל היראה אשונ ریوندلا قانچال یضخت ریوندلا قانچال قباولاً فبول قنول او قنوبنلا Újrahasznosítható csomagolás alá újrahasznosítás Reciklirati predmet recikliranje Pakendite suhtes ringlussevõtu Pärsträdājams iepakojumus otrreizējai pārstrādei Perdirbamų taikomos perdirbimo</p>	X
---	--	---	---





PM 6A

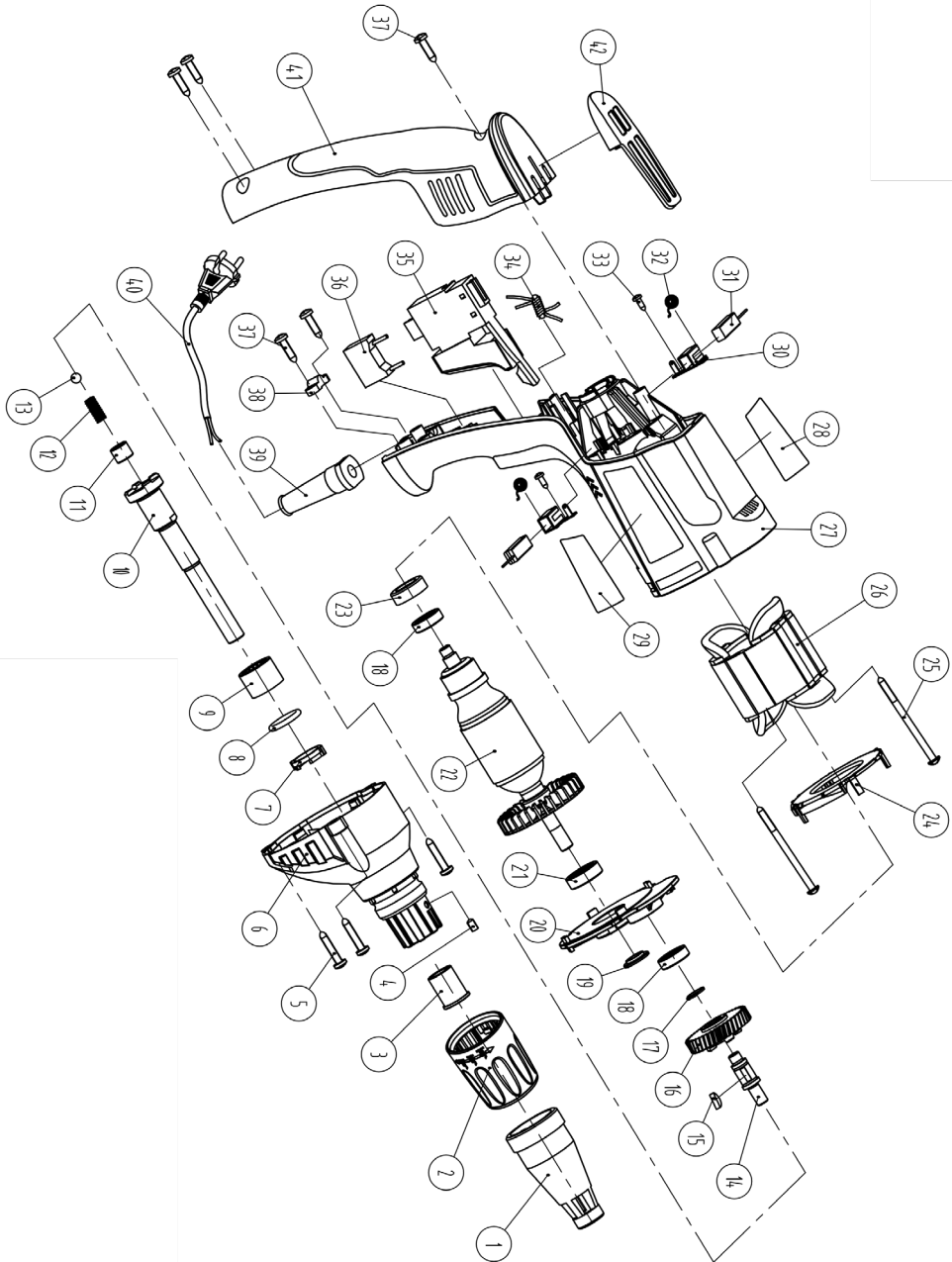



Plaques signalétiques - naamplaatjes - placas de identificación - placas de identificação - targhette - machine labels

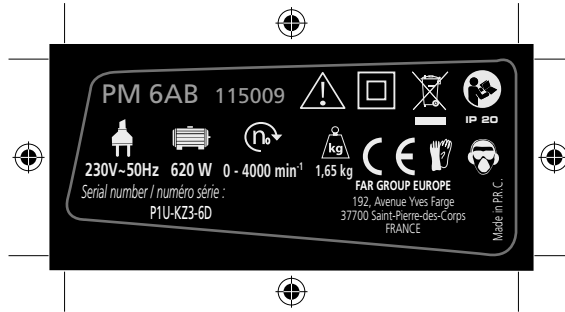

DECLARATION DE CONFORMITE
VERKLARING VAN OVEREENSTEMMING
DECLARACION DE CONFORMIDAD
DICHIARAZIONE DI CONFORMITA
KONFORMITÄSERKLÄRUNG
DECLARATION CONFORMITY
DECLARAÇÃO DE CONFORMIDADE
DEKLARACJA ZGODNOSCI Z NORMAMI
OM ÖVERENSSTÄMMELSE
VAATIMUSTENMUKAISUUSAKTUUS
Overensstemmelseserklæring
Δήλωση συμμόρφωσης/συμμόρφωσης

Declarație de conformitate
Vyhlasenie zhody
Декларация соответствия
הצהרת תואמת
UYGUNLUK BEYANI
التصريح بالاطابقة
Prohlášení shody
Egyezőségi nyilatkozat
Декларация за съответствие с нормите
Izjava o skladnosti
DEKLARACIJA
ΑΠΤΙΚΤΗΣ ΔΕΚΛΑΡΑCΙΑ
KINNITUS

Le soussigné,
Ondergetekende,
Der Unterzeichner,
O abaixo assinado,
Undertecknad,
Долуподписаният
Undertegnede
Subsemmatul,
Я, нижеподписавшийся,
Imzalayan,
Niže potpisany,
Toliau pasirašęs

Personne autorisée à constituer
le dossier technique :
Christophe HUREL



FAR GROUP EUROPE
192, Avenue Yves Farge
37700 Saint-Pierre-des-Corps
FRANCE

El suscrito,
Il sottoscritto,
The undersigned,
Ninej podpisany
Allekirjoittanut,
Ουπτογεγραμμένος
Nižšie potpisany
מתחתום מטה
الموقع أدناه
Alulírott,
Podpisani,
Apakšā parakstījis
allakirjutanu

Declaro por la presente que,
Dichiare che,
Declares that,
OÖwiedcza niniejszym, że
Ilmoittaan täten että,
Δηλώνει με την Παράστα
týmto vyhlasuje, že
מצהיר בה כי
يصدق استنادا على ذلك
kijelentem, hogy a készülék Izjavlja da,
Pareškia, kad,
Ar šo apliecina, ka,
Kinnitat, et

Declare par la présente que,
Verklaart hiermede dat,
Erklärt hiermit daß,
Declara pela presente que,
Förlägar härmed att
Заявява с настоящото
erklarer hermed, at
Declar prin prezenta că,
настоящим подтверждаю, что
Mevcut belgeyle beyan ediliyor ki,
tímto prohlašuje, že,
Pareškia, kad,

Vissense à placoplâtre / Plasterboard screw inserter / Gipsplattenschrauber / Atornillador para placas de yeso / Avvitatrice per cartongesso /
Aparafusadora para gesso / Schroevendraaier voor gipsplaat / Μηχανή βιδώματος για πλάκες γύψου / Wkretarka do płyt kartonowo-gipsowych /
Laastin ruuvaava porakone / Skruvdragare för gipsskivor / Skruemaskine til gipsplader / Машина за завитване с гипсова фурмурия облицовка /
Maşina de însurubat pentru gips-carton / Шуруповерт для гипсокартона / Elektri 'kli' vi' dalama maki nasi / Uzaviračka pro sadru / Uzavírač na sadru /
סימלה הגרמ / ירי ארטל אנגם / Gipsz Karton csavarozó / Vijačnik za mavčne plošče / Kriviceeraja kipsmaterjalidele /
Apmetuna plākšņu skrūvgriezis / Gipsinis tvirtinimo aparatas

code

FARTOOLS / 115009 / PM 6AB / PIU-KZ3-6D

Est conforme et satisfait aux directives et normes CE,
In overeenstemming is met en Voldoet aan EG richtlijnen,
Den folgenden EU-Bestimmungen entspricht,
Respeita e está em conformidade com as normas CE,
Överensstämmer med och uppfyller EG-standarder,
Съответства и отговаря европейските норми
er i overensstemmelse med og overholder EU standarderne
Este conform și satisface normele CE
полностью соответствует и удовлетворяет
требованиям стандартов ЕС
CE şartlara uygundur,
odpovídá normám ES,
Atitinka ir atitinka EB direktyvas ir standartus,

Cumple con la directivas de la CE,
E conforme alle direttive CEE,
Complies with the EEC directives and standards,
Odpowiada normom UE,
Täyttää EU-vaatimukset,
Είναι σύμφωνα και ανταποκρίνεται στα Πρότυπα CE
zodpovedá normám ES,
מתאים ועונה לתקני CE
بأن الجهاز مطابق ويالذي مع مجموعة الدول الأوروبية
kielégíti a CE szabványok előírásait.
Je v skladu z in izpolnjuje norme Evropske skupnosti.
Atbilst un atbilst EK direktīvas un standartus,
Vastab ja vastab EU direktīviudele ja standartiteile,

2006/42/EC 2014/30/EU 2011/65/EU 2015/863/EU

EN 62841-1:2015+AC:15
EN 62841-2-2:2014
EK9-BE-88:2014
EN55014-1:2017
EN55014-2:2015
EN61000-3-2:2014
EN61000-3-3:2013

Christophe HUREL,
Président Directeur Général
20/05/2020
Fait à Saint-Pierre-des-corps



FR. GARANTIE

Cet outil est garanti contractuellement contre tout vice de construction et de matière, à compter de la date de vente à l'utilisateur et sur simple présentation du ticket de caisse. La garantie consiste à remplacer les parties défectueuses. Cette garantie n'est pas applicable en cas d'exploitation non conforme aux normes de l'appareil, ni en cas de dommages causés par des interventions non autorisées ou par négligence de la part de l'acheteur. La garantie ne s'applique pas sur les dommages causés par une défaillance de l'outil.

DE. GARANTIE

Die Garantiezeit für dieses Gerät in bezug auf Konstruktions- und Materialfehler beträgt lt. Vertrag bei Vorlage des Kassenbons. Die Garantieleistung besteht im Ersatz schadhafter Teile. Die Garantie erlischt bei einem Einsatz des Geräts, der nicht normentsprechend ist, bei Schäden, die auf unsachgemäße Eingriffe zurückzuführen sind bzw. bei Nachlässigkeit seitens des Käufers. Die Garantie erstreckt sich nicht auf Schäden, die auf Fehlfunktionen des Geräts zurückzuführen sind.

IT. GARANZIA

Quest' attrezzo è garantito per contratto contro qualsiasi difetto di costruzione e di materia, a partire dalla data di vendita all' utente e su semplice presentazione dello scontrino. La garanzia consiste nel sostituire le parti difettose. Questa garanzia non è applicabile in caso di sfruttamento non conforme alle norme dell' apparecchio, né in caso di danni causati da interventi non autorizzati o da negligenza da parte dell' acquirente. La garanzia non si applica ai danni causati da un' avaria dell' attrezzo.

EN. GARANTEE

This tool is guaranteed, in writing, against any defect in manufacture or parts from the date of sale, upon simple presentation of the sales slip. The guarantee is limited to the replacement of faulty parts. This guarantee is not applicable in the event of usage which is not conform with the intended usage of the apparatus, nor in the event of damage caused by unauthorised servicing or negligence on behalf of the purchaser. This guarantee does not apply to any damage caused by the failure of this tool.

ES. GARANTIA

Esta herramienta se garantiza contractualmente contra todo defecto de construcción y materia, a partir de la fecha de venta a l' usuario y sobre simple presentación del recibo de caja. La garantía consiste en sustituir a las partes defectuosas. Esta garantía no es aplicable en caso de explotación no conforme a las normas del aparato, ni en caso de daños causados por intervenciones no autorizadas o por negligencia por parte del comprador. La garantía no se aplica sobre los daños causados por un fallo del herramienta.

NL. GARANTIE

Dit gereedschap heeft een garantie tegen constructiefouten en materiaaldefecten, die geldig is vanaf de aankoopdatum door de gebruiker, op vertoning van de kassabon. De garantie betreft de vervanging van de defecte onderdelen. Deze garantie is niet van toepassing indien het apparaat niet volgens de normen gebruikt is, noch in geval van schade veroorzaakt door oneigenlijk gebruik of nalatigheid van de koper. De garantie is niet van toepassing op schade voortvloeiend uit een defect van het gereedschap.

PT. GARANTIA

Esta ferramenta tem uma garantia contratual contra qualquer defeito de construção e de material, a partir da data de venda ao utilizador e sobre simples apresentação do talão da caixa.. A garantia consiste em substituir as partes defeituosas. Esta garantia não é aplicável no caso de exploração não conforme às normas do aparelho, nem em caso de danos causados pelas intervenções não autorizadas ou por negligência da parte do comprador. A garantia não se aplica para os danos causados por uma falha da ferramenta.

EL. Εγγύηση

Το εργαλείο αυτό φέρει συμβατική εγγύηση για οποιούδηποτε έλαττωμα κατασκευής απ'ο την ημερομηνία Πώλησης στο χρήστη. με απλή Προσκόμιση της απ'οσ'οειξής αγοράς. Η εγγύηση απτελείται απ'ο την αντικατάσταση των ελαττωματικών τμημάτων. Η Παρούσα εγγύηση οεν εφαρμόζεται σε περίπτωση χρήσης μη σύμφωνα με τα Πρόστυπα της συσκευής. η σε περίπτωση ζημιών που Προκλήθηκε απ'ο μη επαγγελματική επ'εμβαση ή απ'ο αμέλεια του αγοραστή. Η εγγύηση "οεν εφαρμόζεται στις ζημιές που Προκαλούνται απ'ο βλάβη του εργαλείου Σταυρού κενού Διαστημο-Παρέμβυσμα

PL. GWARANCJA

Narz' dzie jest obj' te gwarancj' na wszelkie wady konstrukcyjne i materia[owe, licz'ac od daty sprzed' y u' ytkownikowi i po okazaniu paragonu kasowego. Gwarancj' obejmuje wymian' cz' Aci wybrakowanych. Gwarancj' nie znajduje zastosowania w przypadku u' ytkowania niezgodnego z normami urz'adzenia, ani w przypadku szk'od spowodowanych dzia[aniami niedozwolonymi lub zaniedbaniami ze strony nabywcy. Gwarancj' nie obejmuje szk'od powsta[nych z powodu upadku urz'adzenia.

SV. GARANTI

Detta verktyg har en avtalsenlig garanti mot konstruktions- och materialfel, fr'ån och med tidpunkten f'or anv'andarens ink'op och genom uppvisning av kassakvittot. Garantin best'år i att ers'atta de bristf'alliga delarna. Denna garanti g'aller inte om anv'andningen inte motsvarar apparatens standarder, inte heller vid skador som orsakas av ej till'atna ingrepp eller p' grund av k'oparens v'ardsl'oshet. Garantin g'aller inte f'orskador som orsakats av att verktyget fungerat bristf'alligt.

FI. TAKUU

T'ämän laitteen takuu on voimassa sopimuskunmuksaisesti kattaen kaikki rakenne- ja materiaaliiviat lukien ostop'iv'ast'ä kassakuittia vastaan. Takuu sis'alt'ää viallisten osien korvaamisen. Takuu ei korvaa ohjeidenvastaista k'ytt'ö'ä eikä valtuuttamattomien henkilöiden k'äsittelyst'ä tai ostajan huolimattomuudesta aiheutuneita vahinkoja. Takuu ei vastaa my'ösk'ään toimintah'äiri'öistä aiheutuneita vahinkoja.

BU. Гаранция

Този инструмент е под договорна гаранция срещу всякакъв дефект в изработката и използваните материали, считано от датата на продажба на потребителя и само срещу представяне на касовата бележка. Гаранционното обслужване се състои в замяна на дефектните части. Настоящата гаранция не е валидна когато апаратът се използва по начин, несъответстващ на стандарта за работа с него, както и в случай на щети, нанесени от неоторизирани лица, или вследствие на проявена небрежност от страна на потребителя.

Гаранцията не покрива щети, произтекли вследствие на техническа неизправност на апарата.





DA. GARANTI

Deette værktøj er dækket af en garantikontrakt for konstruktions- og materialefejl, som gælder fra købsdatoen ved visning af kassebonen. Garantien består i at udskifte de defekte dele. Garantien dækker ikke fejl opstået som følge af anvendelse, som ikke overholder standarderne for apparatet, eller skader opstået ved ikke autoriserede indgreb eller sløsethed fra brugerens side. Garantien dækker ikke skader opstået, fordi værktøjet har svigtet.

RO. GARANȚIE

Acest aparat este garantat din punct de vedere contractual împotriva tuturor viciilor de construcție și de material, începând de la data vânzării lui către utilizator și la simpla prezentare a bonului de casă. Garanția constă în înlocuirea componentelor defecte. Această garanție nu se aplică în cazul exploataării în alt mod decât cel recomandat de normele aparatului și nici în caz de stricăciuni provocate de intervenții neautorizate sau prin neglijența cumpărătorului. Garanția nu se aplică asupra pagbelor cauzate de o defectare a aparatului.

RU. ГАРАНТИЯ

Данное изделие обладает имеющей силу контракта гарантией, покрывающей все возможные дефекты изготовления и материала. Гарантия вступает в силу с даты продажи изделия пользователю, для этого достаточно сохранить и предъявить полученный в кассе чек. Гарантия обязывает изготовителя заменить дефектные части изделия. В случае не соответствующего нормам использования изделия, несанкционированного демонтажа или ремонта или небрежного обращения действие гарантии прекращается. Гарантия не покрывает ущерб, возникшего в результате сбоев в работе изделия.

TU. GARANTI

Bu araç, satış tarihinden itibaren, kullanıcının sadece vezne alındısını summasıyla tüm üretim ve malzeme hatasına karşı garantilidir. Garanti eksik olan kısımları değiştirmek içindir. Bu garanti aracın şartlarına uygun olmayan işleme durumunda, izin verilmeyen kullanımlardan kaynaklanan hasarlarda veya alıcının isteği durumunda uygulanmaz. Garanti malzemenin bir eksikliğinden meydana gelen bir zararda uygulanmaz.

CS. ZÁRUKA

Pro tento nástroj platí smluvní záruka na všechny výrobní a materiálové vady od data prodeje uživateli a na základě předložení pokladničního bloku. Záruka spočívá ve výměně vadných částí. Tato záruka neplatí v případě použití přístroje, které neodpovídá normám, ani v případě škod způsobených nepovolenými zásahy nebo nedbalostí ze strany kupujícího. Záruka se nevztahuje na škody způsobené závadou nástroje.

SK. ZÁRUKA

Pre tento nástroj platí zmluvná záruka na všetky výrobné a materiálové chyby od dátumu predaja užívateľovi a na základe predloženia pokladničného bloku. Záruka spočíva vo výmene chybných častí. Táto záruka neplatí v prípade použitia prístroja, ktoré nezodpovedá normám, ani v prípade škôd spôsobených nepovolenými zásahmi alebo nedbalosťou zo strany kupujúceho. Záruka sa nevzťahuje na škody spôsobené poruchou nástroja

HE. אחריות

הי עלכלי זה חלה אחריות לפי חוזה מפיץ או ביצור או בחומר, החל מיום המכירה למשתמש עם הצגת חשבונית קופה. האחריות-משמעה החלפת תחלקים הלקויים אחריות זו אינה חלה במקרה של שימוש במכשיר שאינו מתאים לתקנים ובמקרה של נזק שנגרם על ידי התערביו תללא שמכות או על ידי רשלנות מאת הקונה. האחריות אינה חלה על נזק שנגרם על ידי תקלה בכלי.

AR. الضمان

إن هذه الة مضمونة تعاقديا من أي عيب فني التصني عوفي الجواد، إعتبارا من تاريخ البيع الی المستعمل وبناا علی مجرد تقديم بطاقتالشراء یتدل ق الضمان فباي ستبدال الأجزاء ال عاطلة لا یلون هذا الضمان قابل للتطبيق فی حالة الأستخدام غیر البطابق لمعايير الأجهزة، ولذا فی حالة تعرضه لإتلافات ناتجة عن عملیات تدخل غیر مرخصة أو فی حالة الأفعال من قبل المشتري لا یطبق الضمان علی الضرر الناتج عن غل

HU. GARANCIA

Erre a szerszámra szerződéses garanciát vállalunk bármilyen gyártási és anyaghiba felmerülése esetére, a fogyasztó részére történt eladás napjától számítva, a pénztári blokk egyszerű felmutatása ellenében. A garancia a hibás alkatrészek cseréjére terjed ki. Ez a garancia nem érvényes, ha a készüléket nem rendeltetésszerűen használták, sem illetéktelen beavatkozások, vagy a vásárló hanyagsága okozta károk esetén. A garancia nem fedezi azokat a károkat, melyeket a szerszám hibás működése okozott.

SL. GARANCIJA

To orodje je z garancijsko pogodbo zaščiteno proti vsem napakam v izdelavi in v sestavnem materialu od datuma prodaje naprej in ta velja ob predložitvi blagajniškega računa . Garancija velja za zamenjavo delov z napako. Ta garancija ne velja za uporabo orodja, ki ni v skladu z normami, predpisanimi za omenjeno orodje in za primere okvar, ki nastanejo zaradi nedovoljenih posegov na orodju ali zaradi malomarnega rokovanja kupca. Garancija ne velja za škodo, ki jo lahko povzroči okvara orodja.

ET. GARANTII :

See tööriist kuulub lepingu järgi garantiiremonti arvestades alates müümise päevast ja kassatšeki alusel kasutatjale kõigi konstruktsiooni- ja materjalivigade puhul. Garantii seisneb defektsete osade väljavahetamisest. See garantii ei kehti aparaadi normide ebatavalise eiramise puhul ega ostja poolt keelatud viisil kasutamisest või hooletussejätmisest tulenevate kahjude korral. Garantii ei kehti seadme defektidest põhjustatud kahjude puhul

LV. GARANTIJA :

Šis prietaisys yra uztikrinamas kaip itin geros kokybės, nuo jo pardavimo datos iki jo panaudojimo, ir jam yra suteikiamas garantinis talonas. Garantijos metu galima pakeisti atsiradusius trumplataikius gedimus. Ši garantija netaikoma esant netinkamam naudojimui ar nesilaikant reikiam šio aparato vartojimo instrukcijų, tai pat pačiam pirkėjui jį sugadinus. Garantija taip pat netaikoma, prietaisą naudojant ne pagal paskirtį ir jį apgadinus

LT. GARANTIJA :

Šim darbarikam ir įrigumā noteikta garantija visiem defektiem, kas saistās ar konstrukciju un materiālu, sākot ar pārdošanas datumu, kad mašīnu pārdod lietotājam un vienkārši uzrādot kases čeku. Garantija iekļauj bojāto daļu nomaiņu. Šī garantija nav derīga, ja aparāts nav lietots saskaņā ar drošības noteikumiem, ne gadījumos ja bojājumi radušies nesankcionētās iekļaušanās gadījumā vai arī pircēja nolaidības dēļ. Garantija nav derīga, ja bojājumi radušies darbarika defekta dēļ

