

A

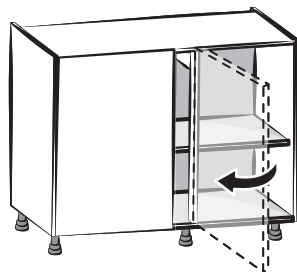

B

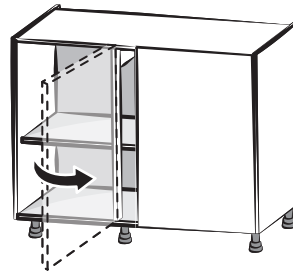

FR Manuel d'Instructions

ES Manual de Instrucciones

PT Manual de Instruções

IT Manuale di Istruzioni

EL Εγχειρίδιο Οδηγών

PL Instrukcja Obsługi

RO Manual de instructiuni

EN Instructions Manual

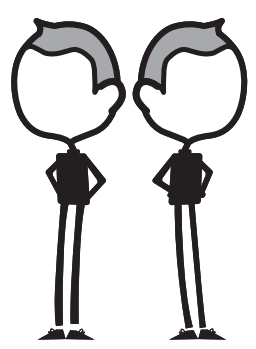
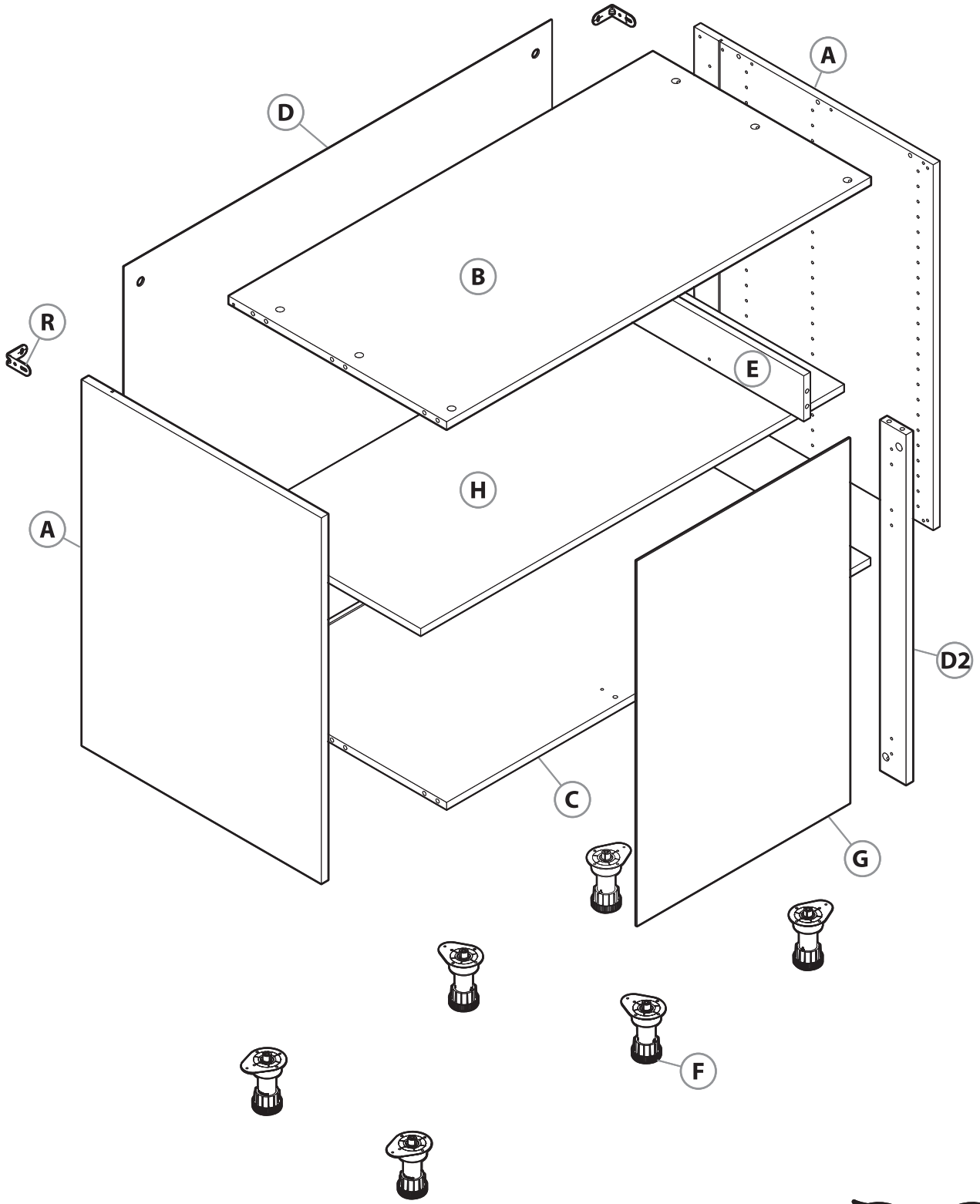



0 1 2 3 4 5 cm

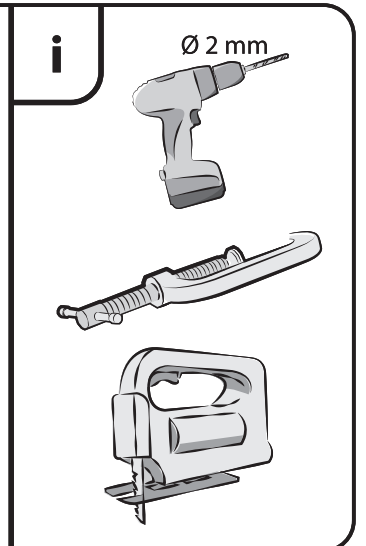
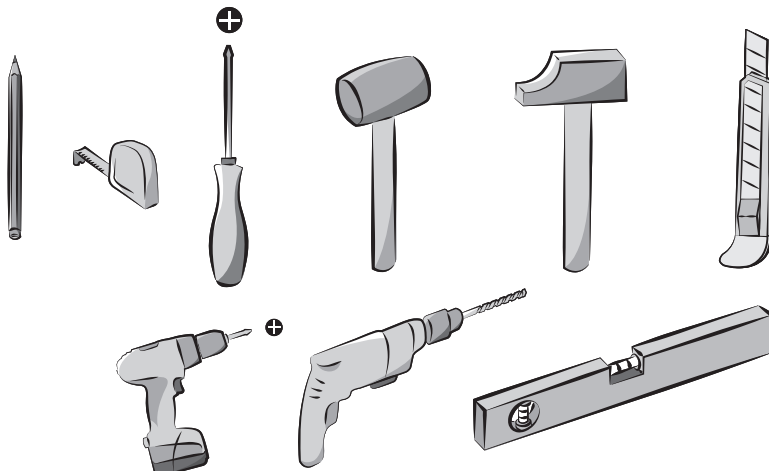
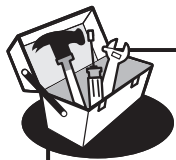
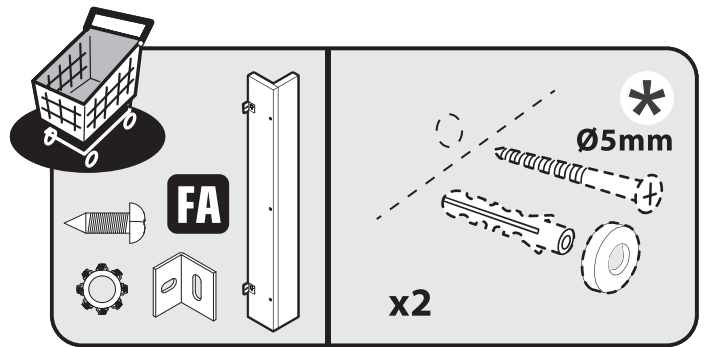
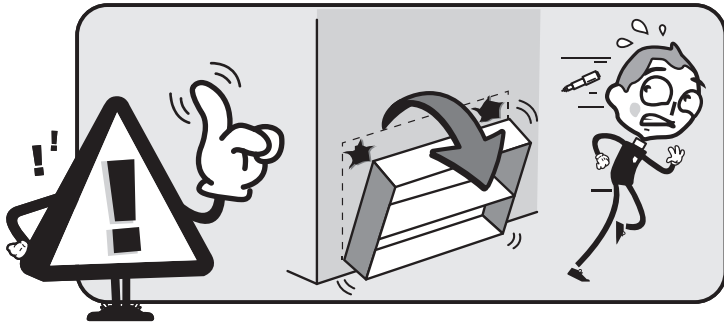
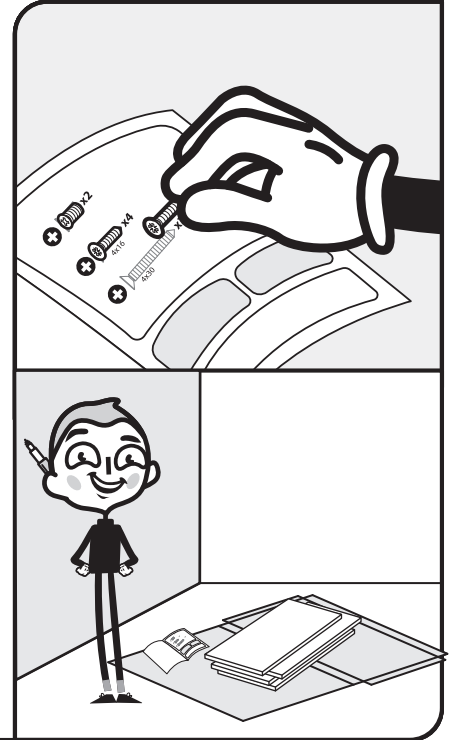
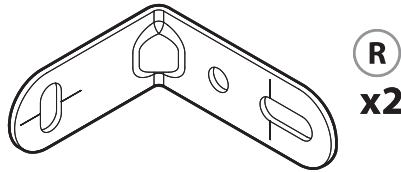
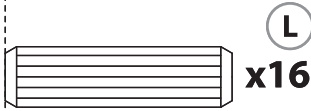
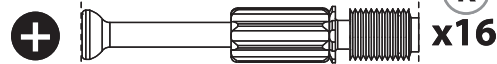
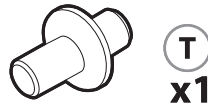
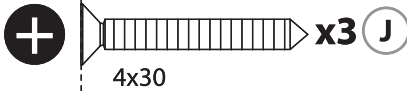

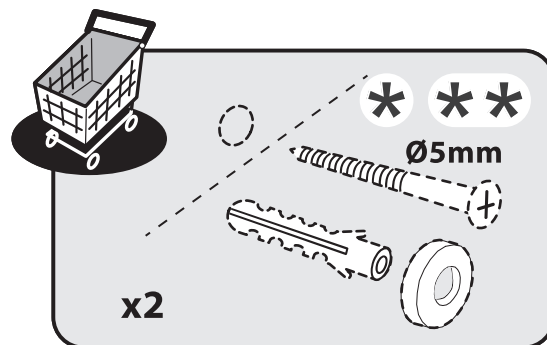
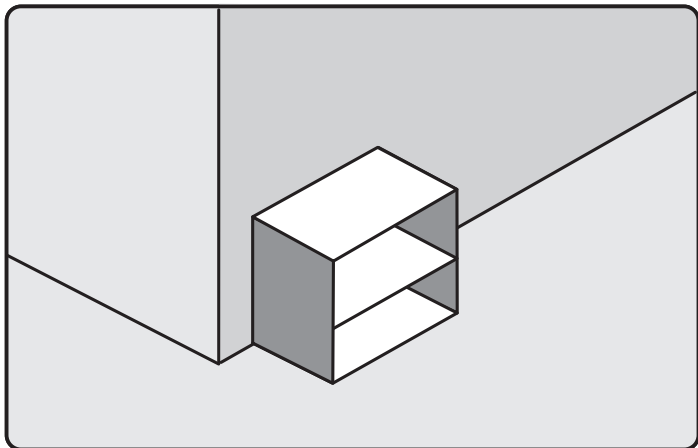
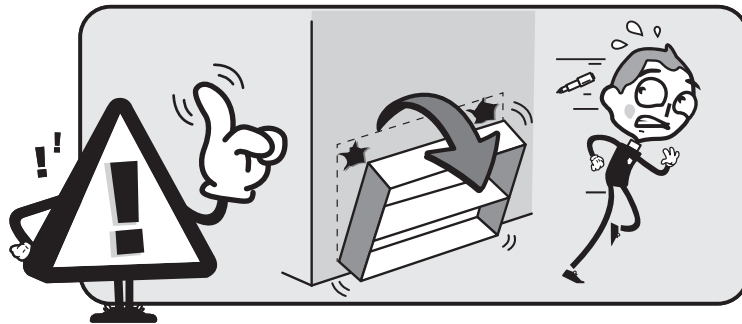

FR/ AVERTISSEMENT :

Pour éviter tout risque de basculement, ce meuble/cet objet doit être solidement fixé au mur. Vérifier la pertinence et la solidité du mur afin de s'assurer que le mur puisse supporter la charge du meuble/de l'objet et résister aux forces générées au niveau des fixations. Un montage mal effectué peut provoquer la chute du meuble/de l'objet et des blessures graves sur les personnes. En cas de doute concernant l'installation, demandez conseil à un vendeur spécialisé ou contactez un professionnel.

★ Utilisez des vis, rondelles et chevilles adaptées au type de matériau de votre mur. Celles-ci ne sont pas incluses. Pour obtenir des conseils sur les vis et ferrures adaptées à votre mur, adressez-vous à un vendeur spécialisé.

PT/ AVISO:

Para evitar qualquer risco de basculamento, este móvel/objeto deve ser fixo à parede de forma segura. Verifique a adequabilidade e solidez da parede para se certificar de que pode suportar a carga do móvel/objeto e resistir às forças aplicadas ao nível das fixações. Uma montagem mal feita pode originar a queda do móvel/objeto e provocar danos pessoais graves. Em caso de dúvida em relação à instalação, peça aconselhamento a um vendedor especializado ou contacte um profissional.

★ Utilize parafusos, anilhas e buchas adaptadas ao tipo de material da sua parede. Estes elementos de fixação não estão incluídos. Para obter aconselhamento sobre os parafusos e ferragens adaptados à sua parede, consulte um vendedor especializado.

EL/ ΠΡΟΕΙΔΟΠΟΙΗΣΗ:

Για την αποφυγή οποιουδήποτε κινδύνου ανατροπής, το έπιπλο/ αντικείμενο πρέπει να στερεώνεται σταθερά στον τοίχο. Βεβαιωθείτε για την καταλληλότητα και σταθερότητα του τοίχου, προκειμένου να διασφαλίσετε ότι μπορεί να υποστηρίξει το φορτίο του επίπλου/ αντικειμένου και να αντέξει στις δυνάμεις που δημιουργούνται στα σημεία των στηριγμάτων. Η κακή τοποθέτηση μπορεί να οδηγήσει σε πτώση του επίπλου/ αντικειμένου και σοβαρούς τραυματισμούς ατόμων. Σε περίπτωση αμφιβολίας σχετικά με την εγκατάσταση, ζητήστε συμβουλές από έναν εξειδικευμένο πωλητή ή καλέστε έναν επαγγελματία.

★ Χρησιμοποιήστε κατάλληλες βίδες, ροδέλες και ούπα ανάλογα με το υλικό της τοιχοποιίας σας. Τα υλικά αυτά δεν περιλαμβάνονται. Για συμβουλές σχετικά με τις βίδες και τα μεταλλικά στηρίγματα που ενδείκνυνται για τον τοίχο σας, απευθυνθείτε σε έναν εξειδικευμένο πωλητή.

RO/ AVERTIZARE:

Pentru a evita orice risc de basculare, această mobilă/acest obiect trebuie fixat/ă bine de perete. Verificați rezistența și soliditatea peretelui, pentru a vă asigura că acesta poate suporta greutatea mobilei/obiectului și poate rezista forțelor generate la nivelul dispozitivelor de fixare. Montarea efectuată greșit poate determina căderea mobilei/obiectului și vătămarea gravă a persoanelor. În caz de dubii privind instalarea, cereți sfatul unui comerciant specializat sau contactați un profesionist.

★ Utilizați șuruburi, șaibe și dibluri adaptate tipului de material a peretelui. Acestea nu sunt incluse. Pentru a obține recomandări privind șuruburile și piesele adaptate peretelui dvs., adresați-vă unui comerciant specializat.

ES/ ADVERTENCIA:

Para evitar cualquier riesgo de que se vuelque, el mueble u objeto debe anclarse firmemente a la pared. Compruebe la adecuación y la solidez de la pared para asegurarse de que puede soportar el peso del mueble u objeto y resistir las fuerzas que se produzcan en las fijaciones. Un montaje inadecuado puede causar la caída del mueble u objeto y que se produzcan daños corporales. En caso de duda en relación a la instalación, pregunte a un vendedor especializado o recurra a un profesional.

★ Utilice tornillos, arandelas y tacos adecuados para el material de la pared. El producto no incluye la tornillería ni los tacos de sujeción. Para saber cuáles son los elementos de fijación más adecuados para su pared, pregunte a un vendedor especializado.

IT/ ATTENZIONE:

Per evitare un eventuale rischio di ribaltamento, il mobile/l'oggetto deve essere saldamente fissato alla parete. Verificare l'adeguatezza e la solidità della parete per essere sicuri che la stessa possa sopportare il carico del mobile/dell'oggetto e resistere alle forze generate a livello di fissaggi. Un montaggio non effettuato correttamente può provocare la caduta del mobile/dell'oggetto e lesioni gravi alle persone. In caso di dubbio circa l'installazione, rivolgetevi a un venditore specializzato o contattate un professionista.

★ Utilizzare viti, rondelle e Pernotti (non inclusi) adeguati al tipo di materiale della vostra parete. (non inclusi) Per informazioni su viti e ferramenta adatti alla vostra parete, rivolgetevi a un venditore specializzato.

PL/ OSTRZEŻENIE:

Aby uniknąć ryzyka przewrócenia, mebel/produkt musi zostać solidnie przymocowany do ściany. Sprawdź, czy ściana jest odpowiednia i solidna, aby mieć pewność, że jest w stanie utrzymać obciążenie mebla/produktu i siły na poziomie mocowań. Nieprawidłowo wykonany montaż może spowodować upadek mebla/produktu prowadzący do poważnych obrażeń ciała. W razie wątpliwości dotyczących montażu, należy zasięgnąć porady u kompetentnego sprzedawcy lub skontaktować się z fachowcem.

★ Użyj śrub, podkładek i kołków odpowiednich do rodzaju ściany. Elementy te nie są dołączone do zestawu. Aby zasięgnąć porady na temat odpowiednich śrub i okuć należy skontaktować się z kompetentnym sprzedawcą.

EN/ WARNING:

To avoid any risk of toppling, this furniture item/object must be securely attached to the wall. Check the suitability and the strength of the wall to ensure that the wall can bear the load of the furniture/object and withstand the forces put on the securing elements. Improper installation can result in the furniture/object falling and cause serious injuries to people. In case of a doubt regarding the installation, ask for advice from a specialised sales assistant or contact a professional.

★ Use screws, washers and plugs suited to the type of material of your wall. These are not included. To obtain advice on the screws and fittings suited to your wall, ask a specialised sales assistant.

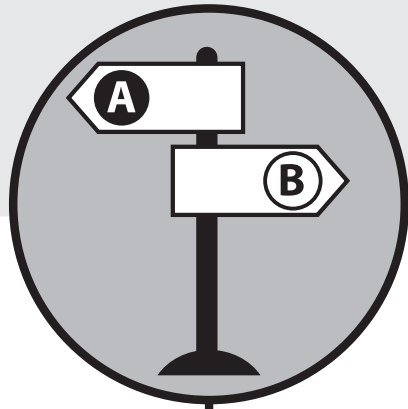

A

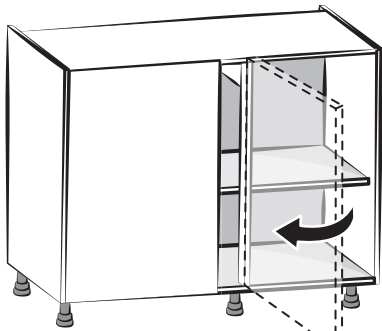

1 A



B

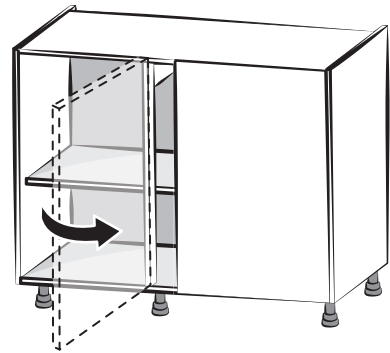

1 B



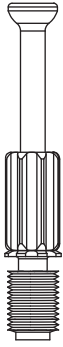

K
x12

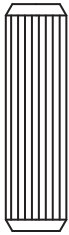

L
x12



I
x2



R
x2

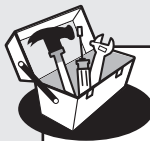

A

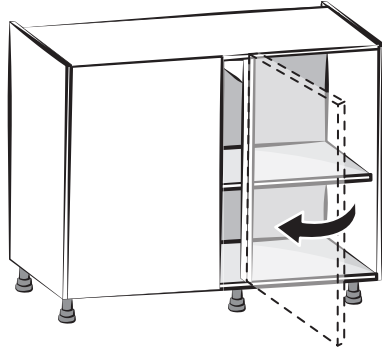

1 A

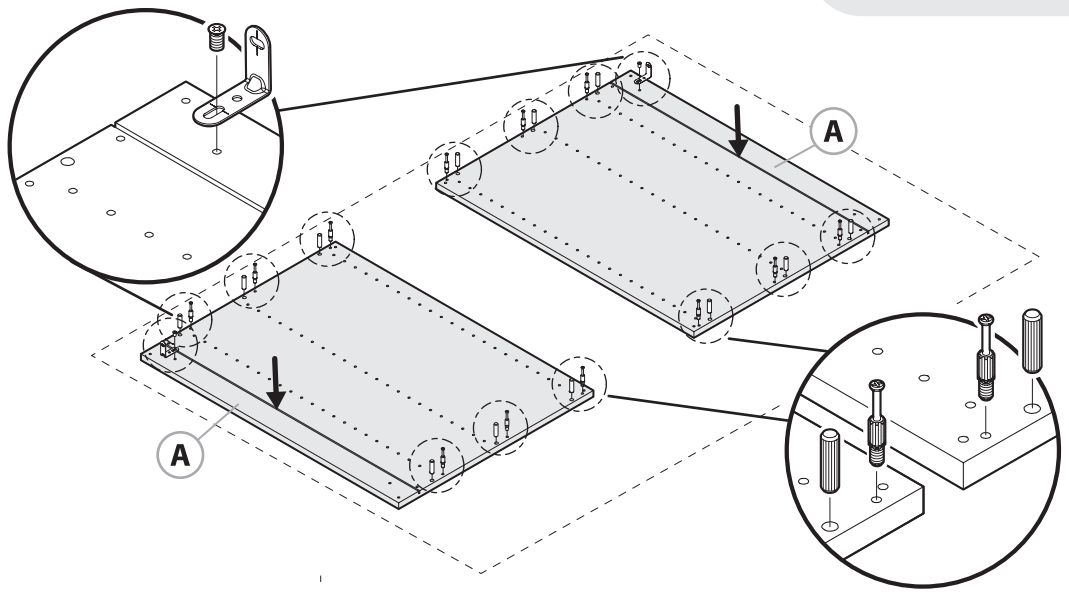
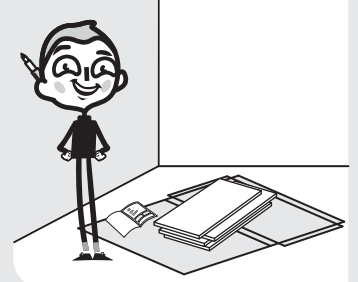

2 A



i

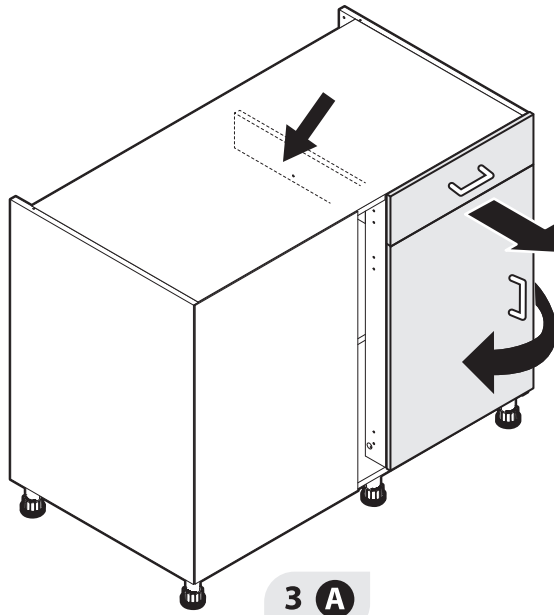
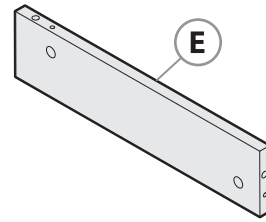
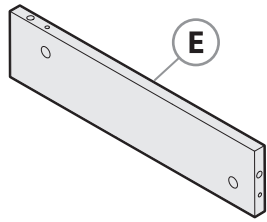

3 A

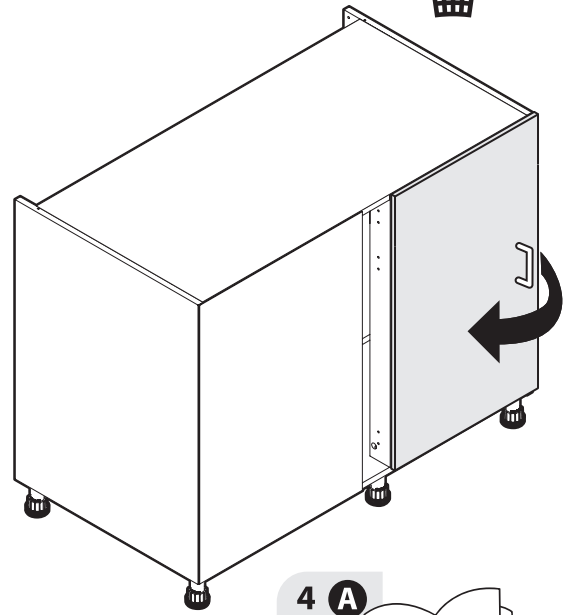

4 A

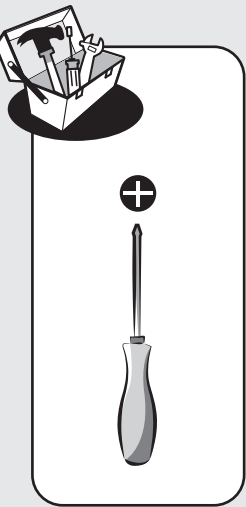
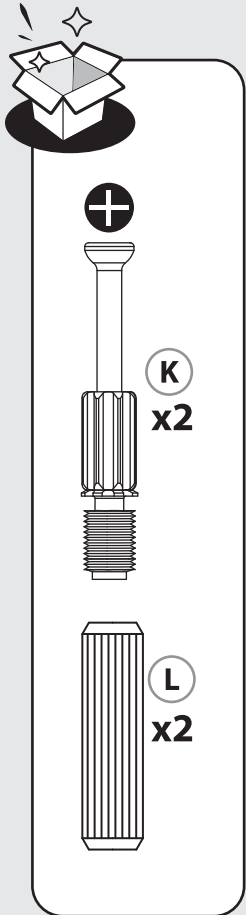

3 A

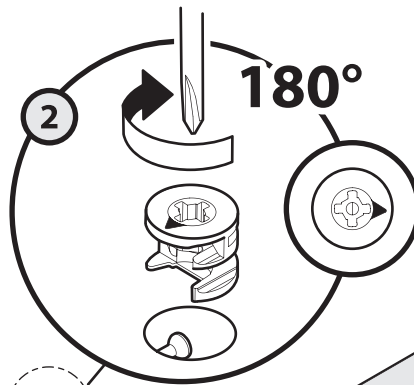

180°

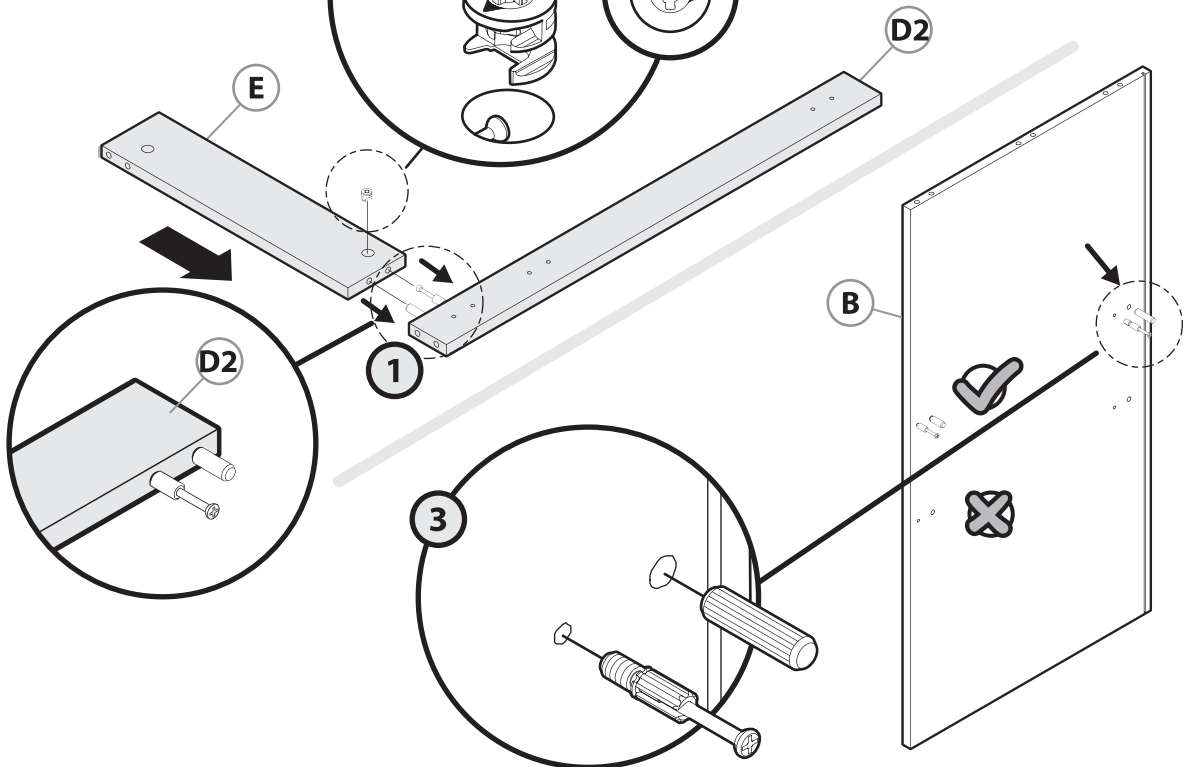

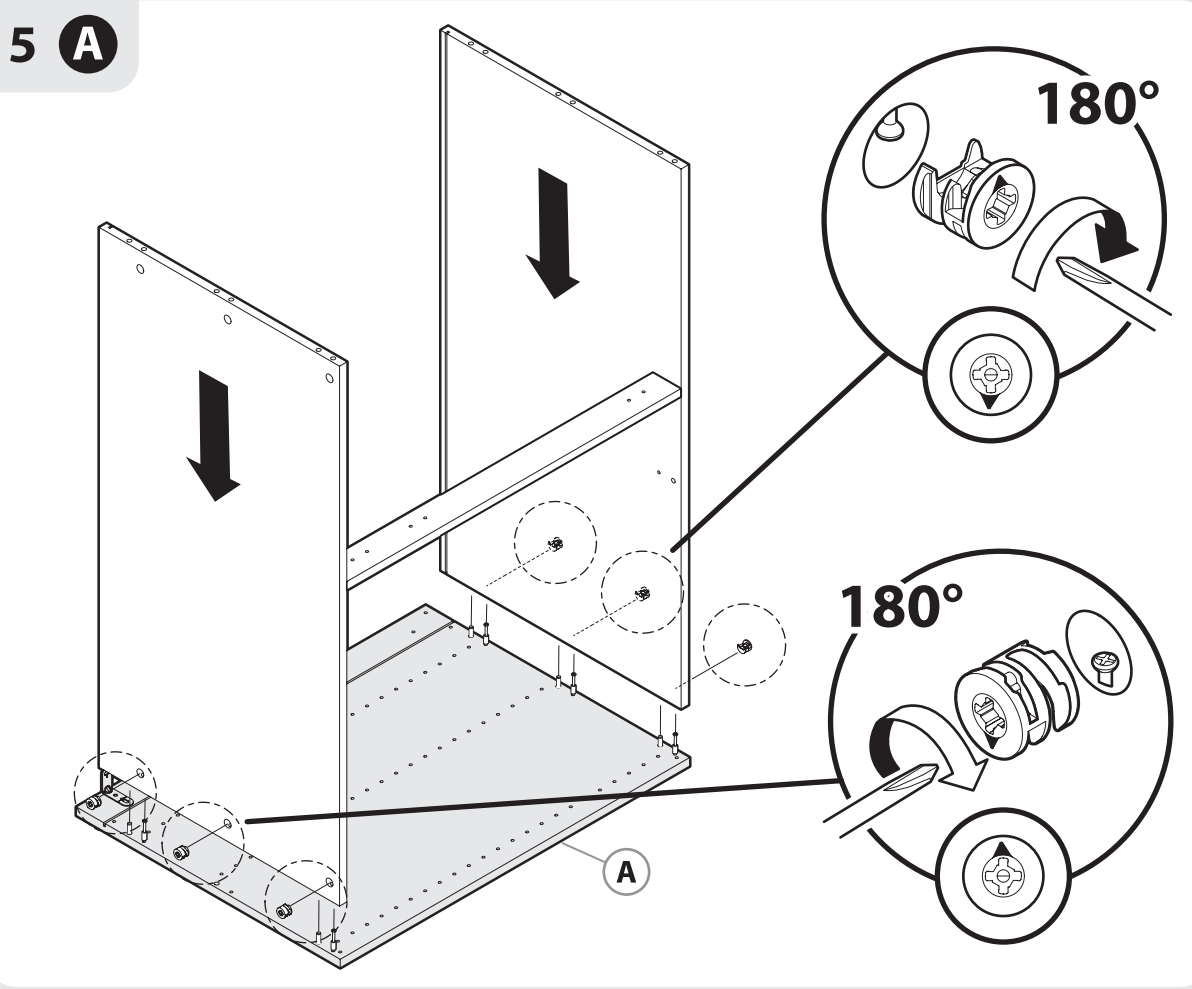
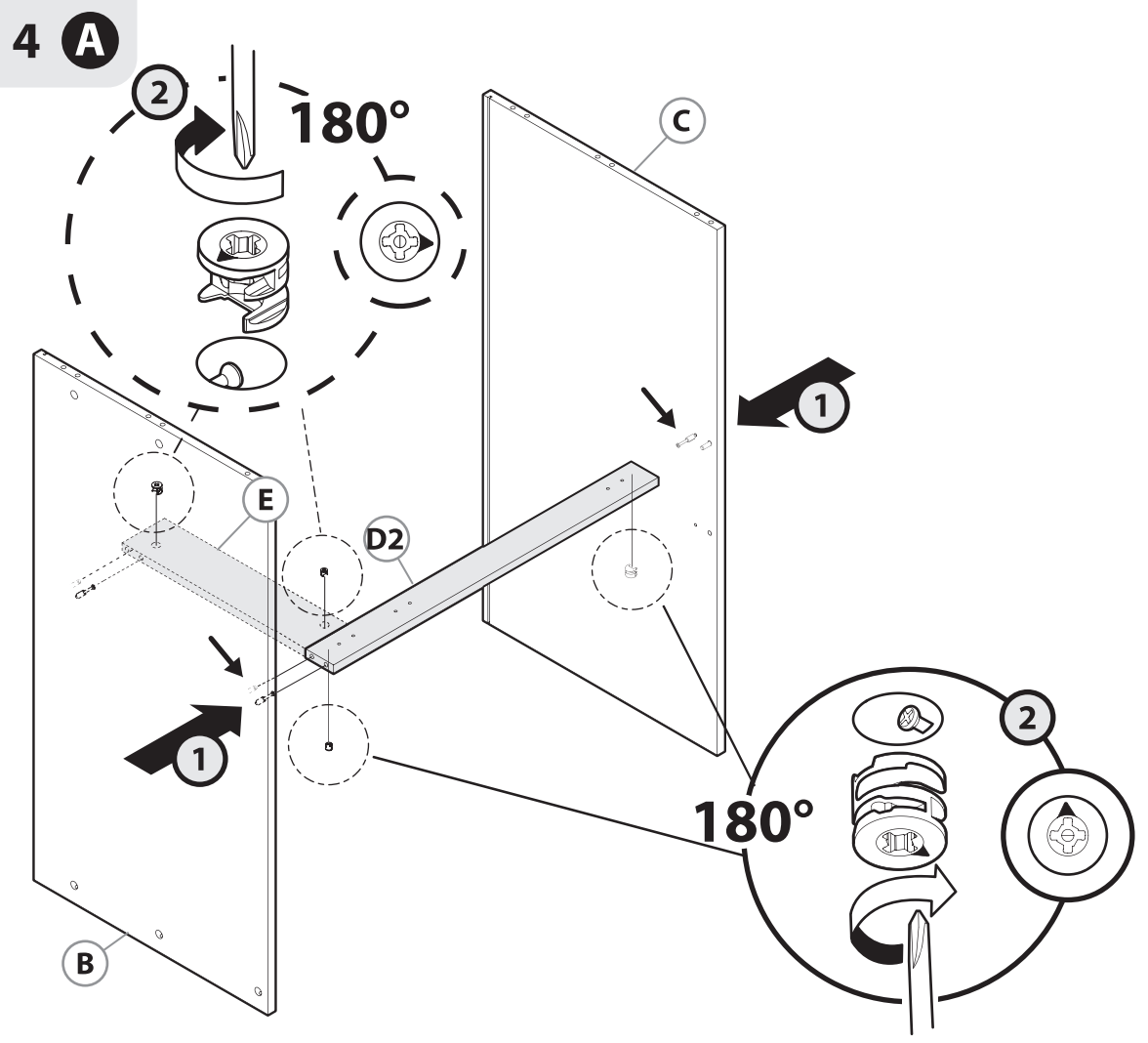
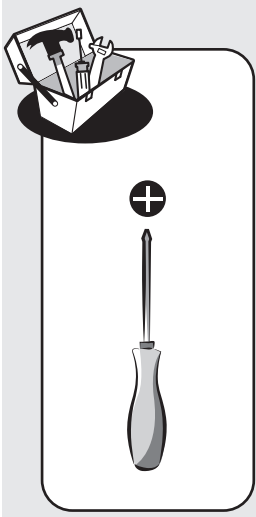
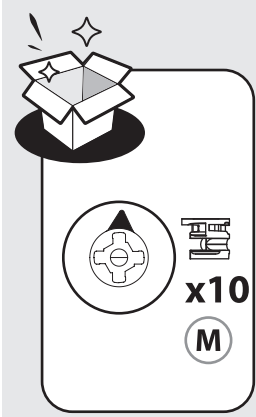

6 **A**

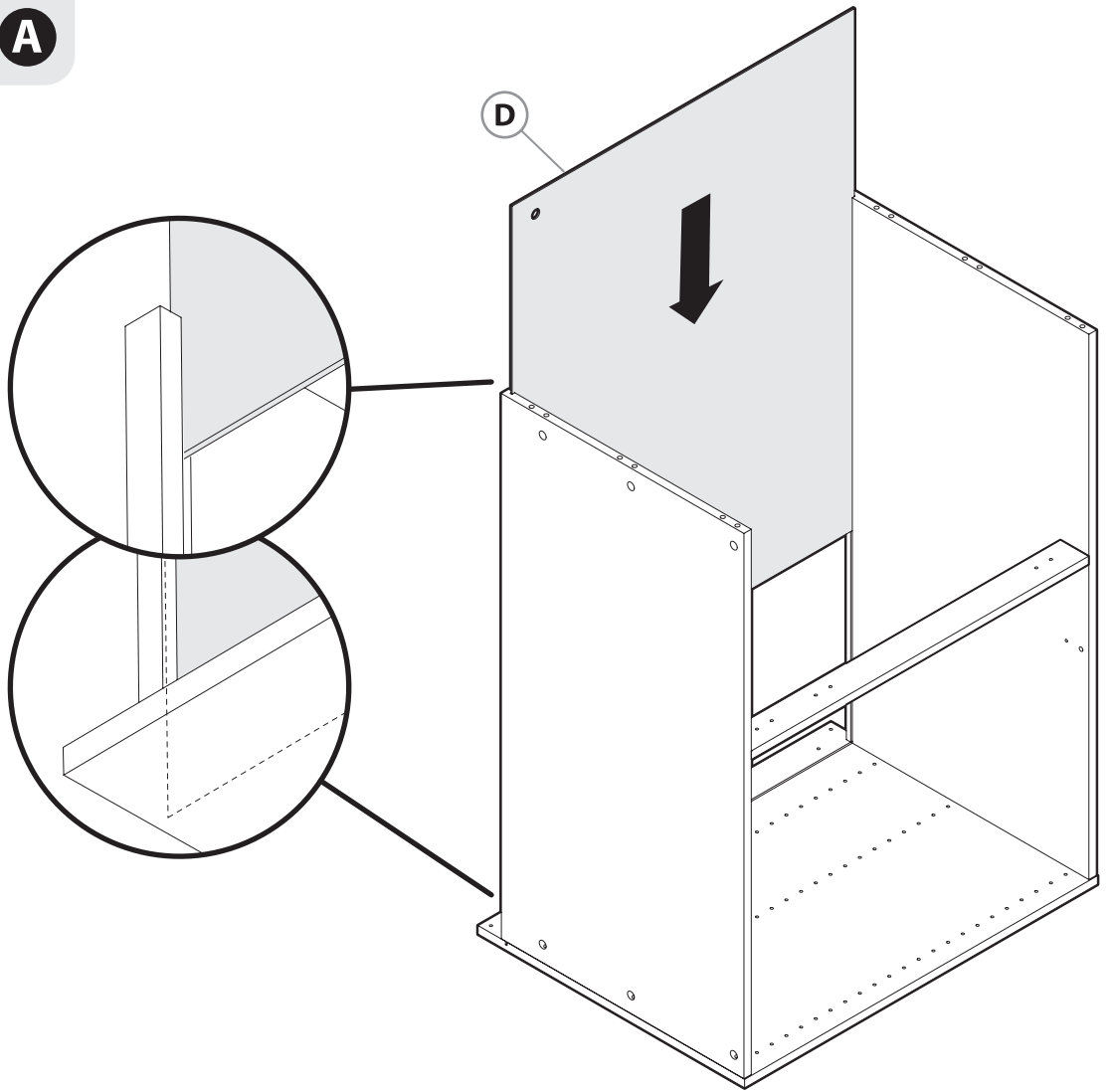
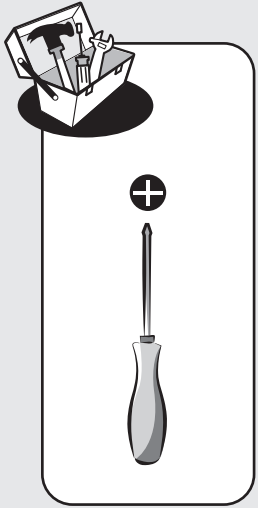
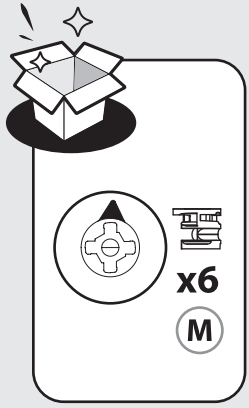

7 **A**

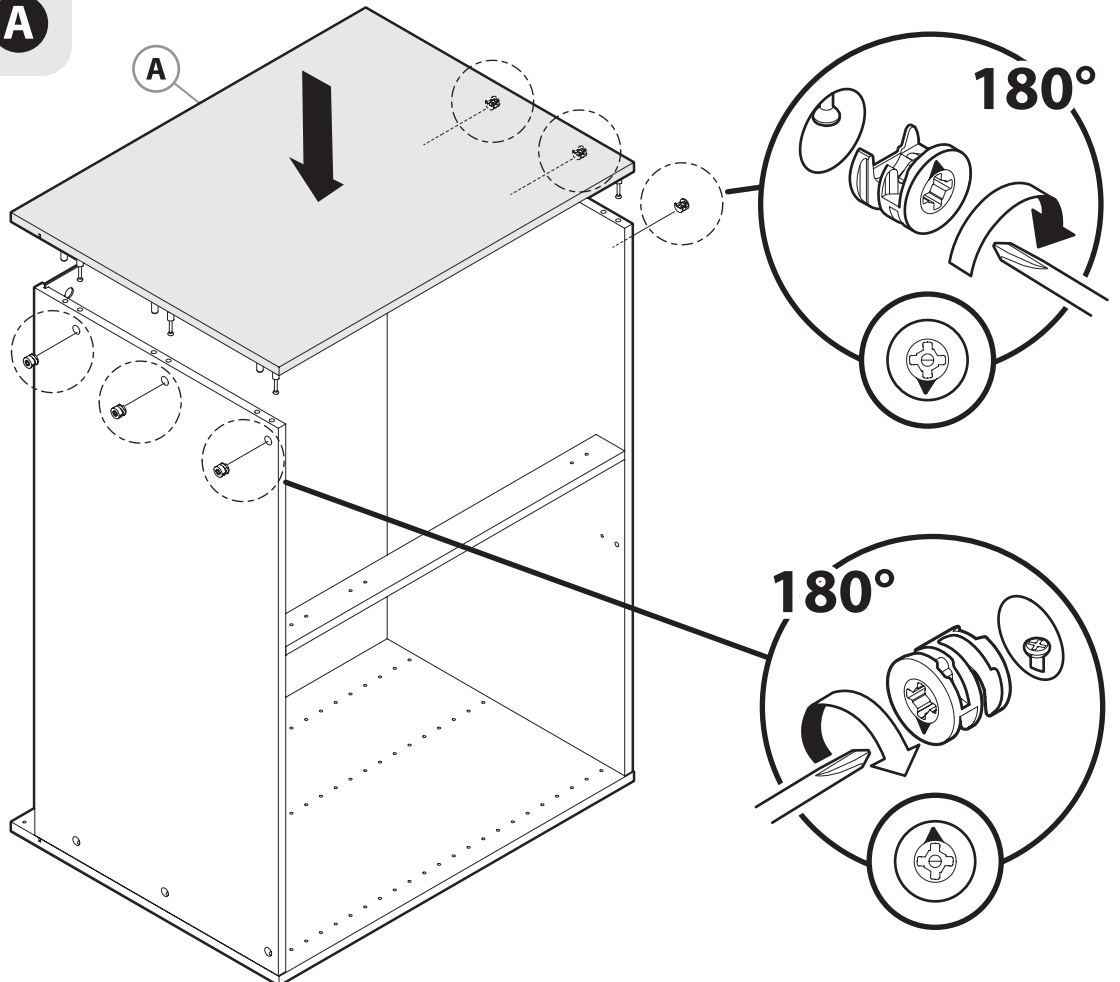

8 **A**



M



x6



Q

x12



+

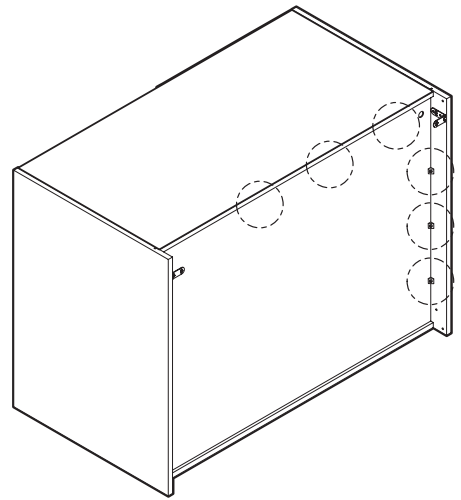
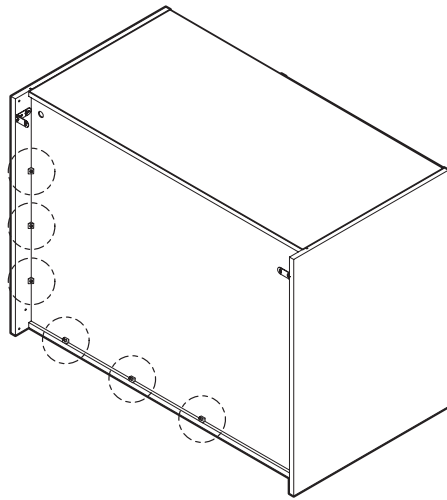
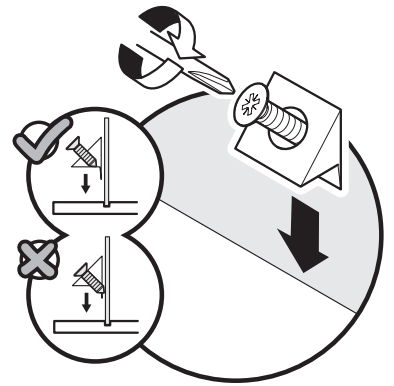
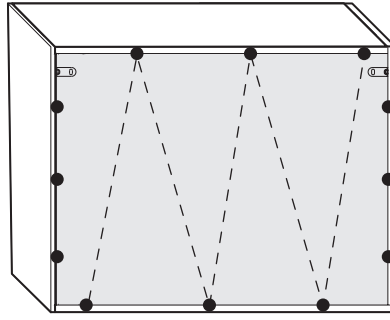

i

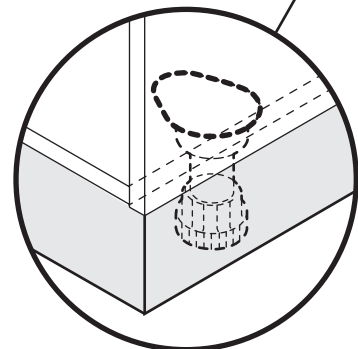
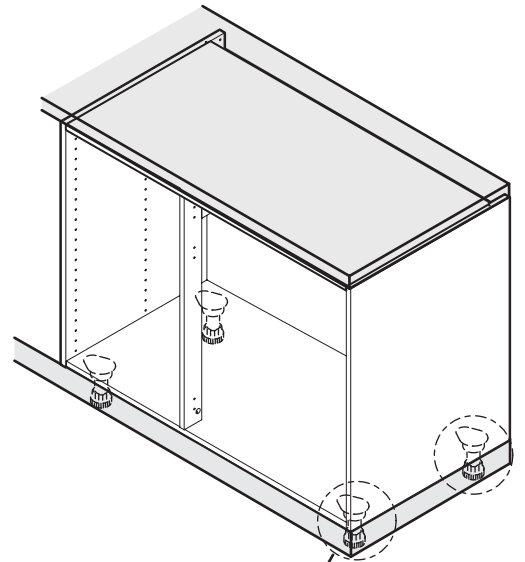
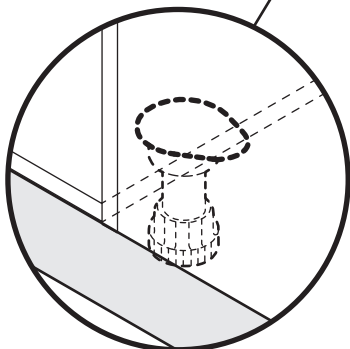
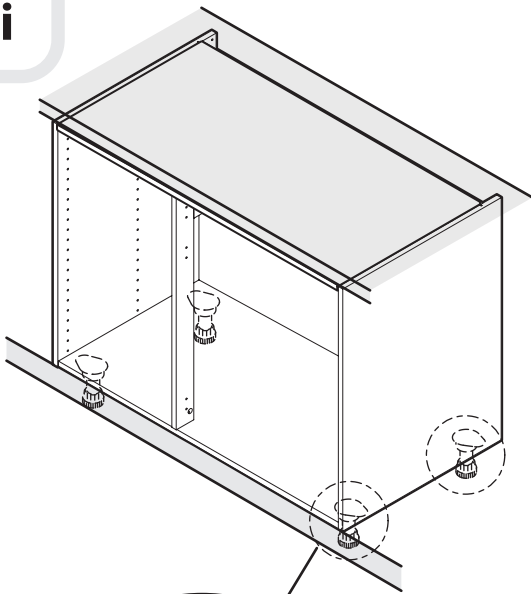

9 **A**

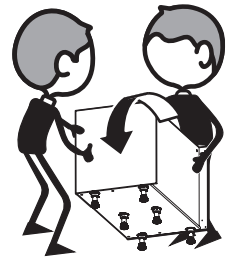
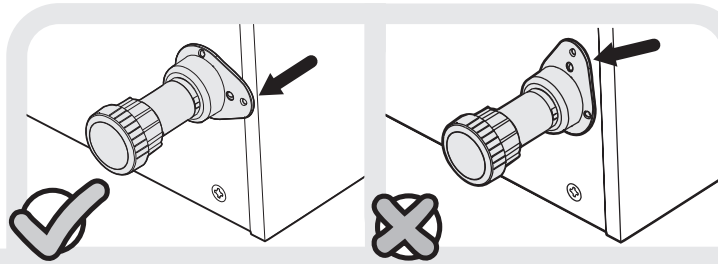
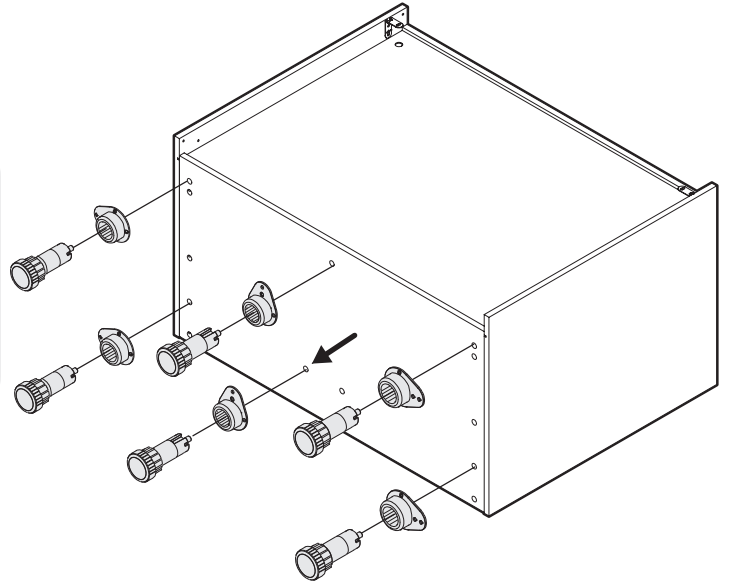
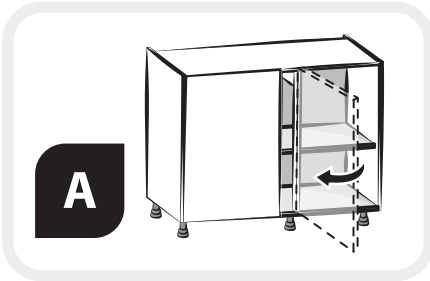
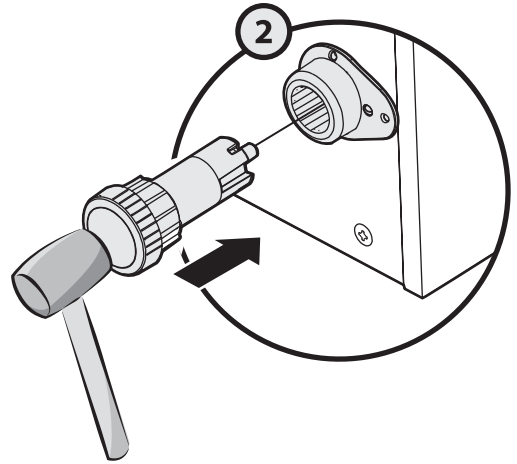
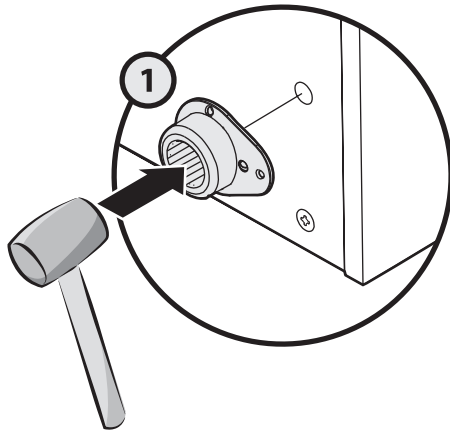
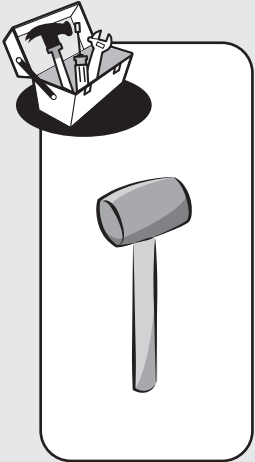
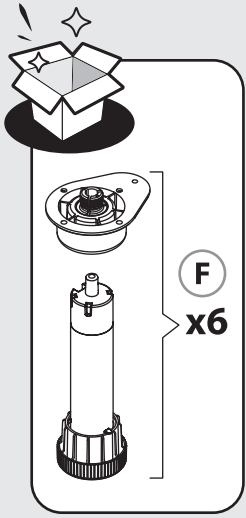

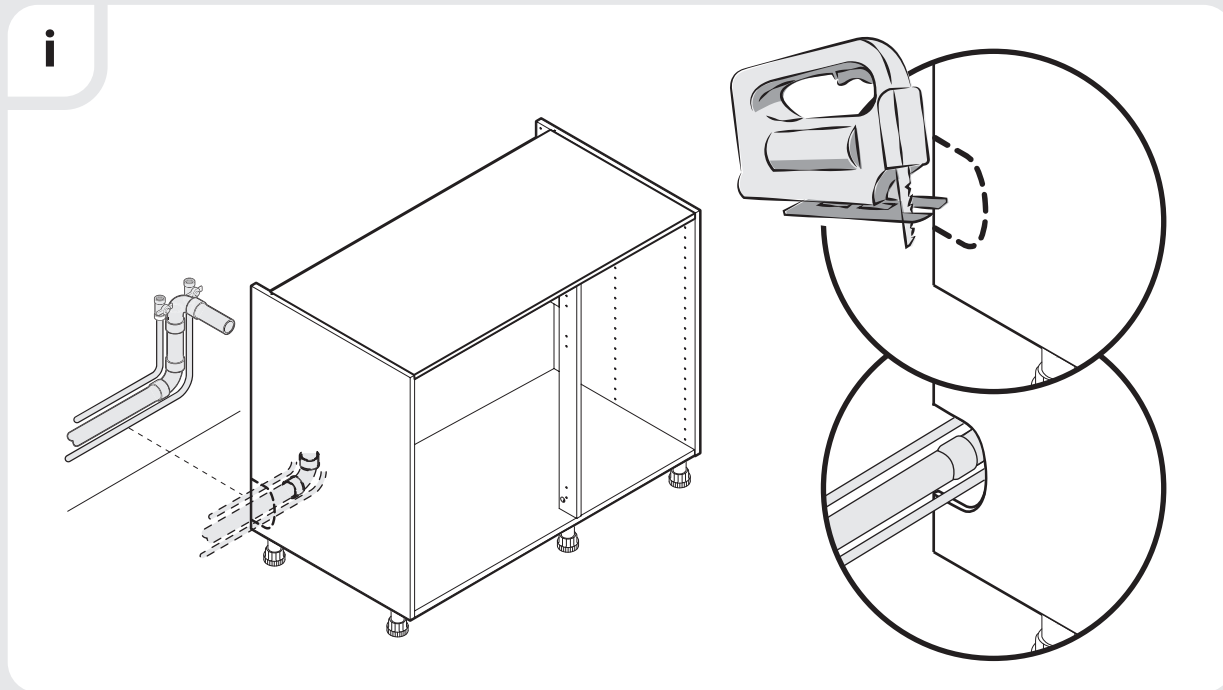
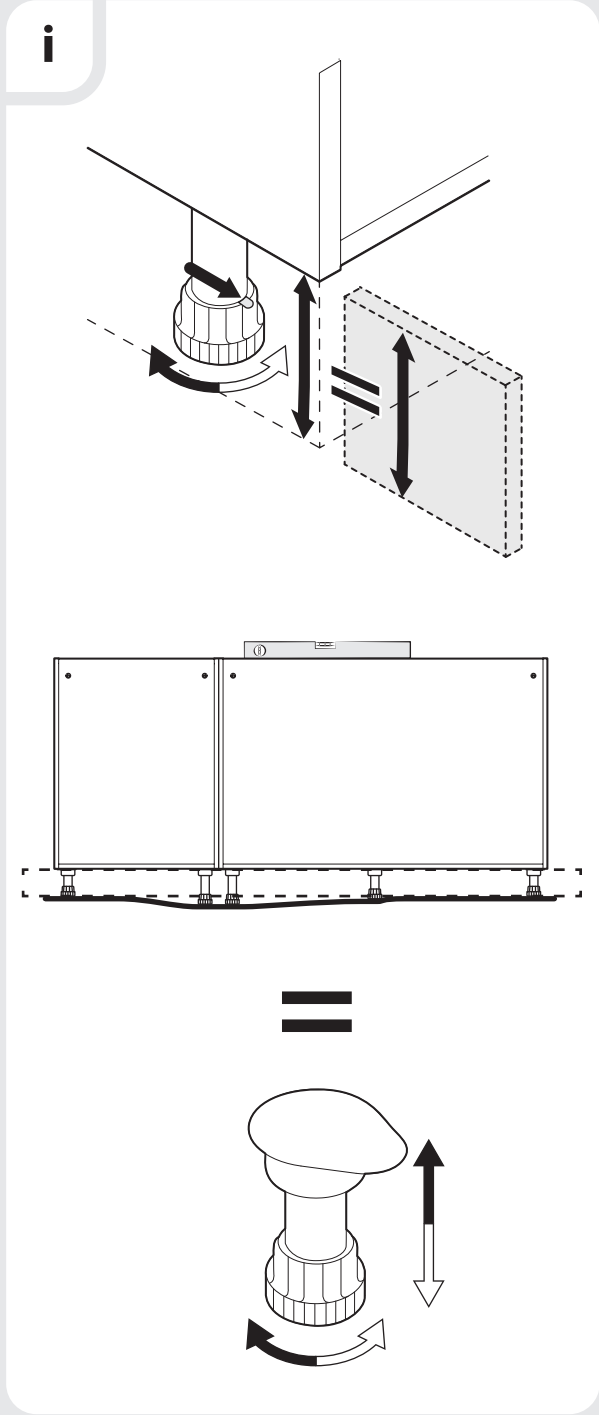
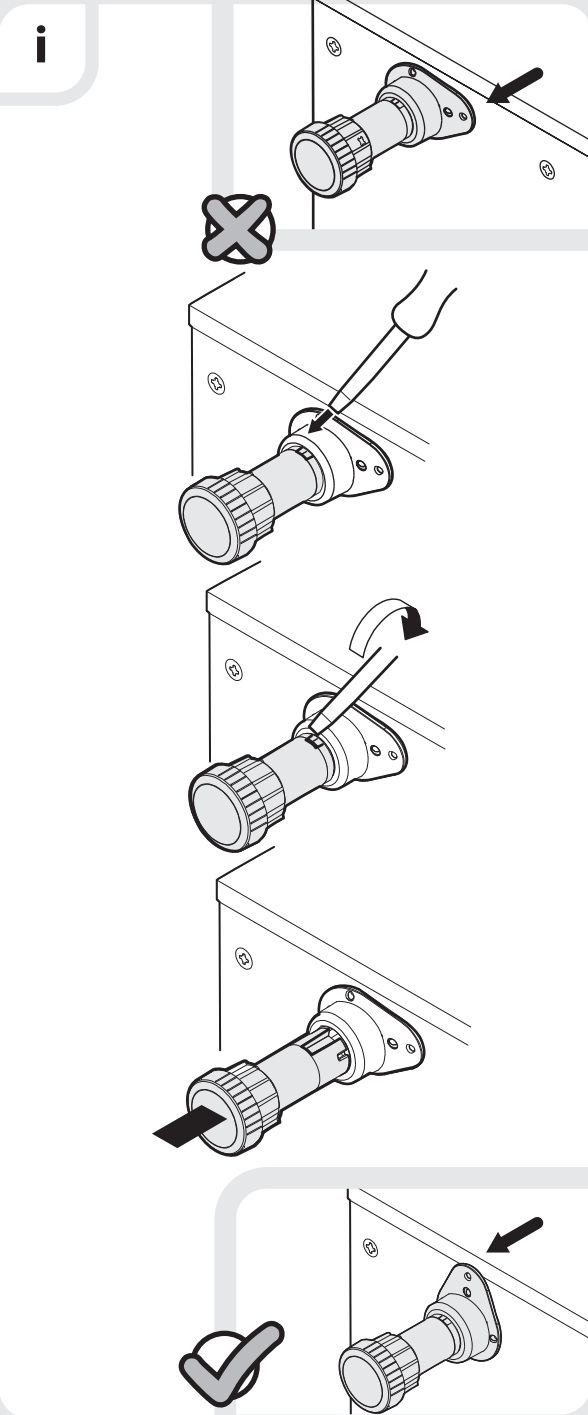
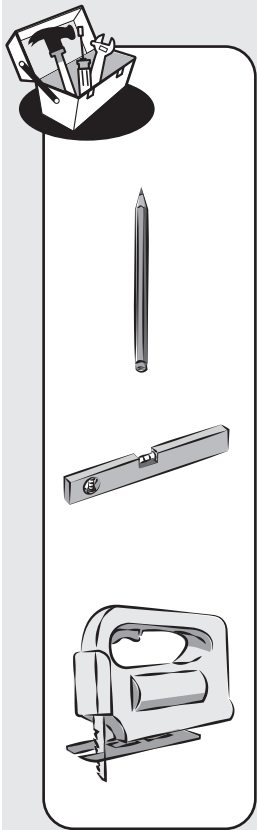

10 A

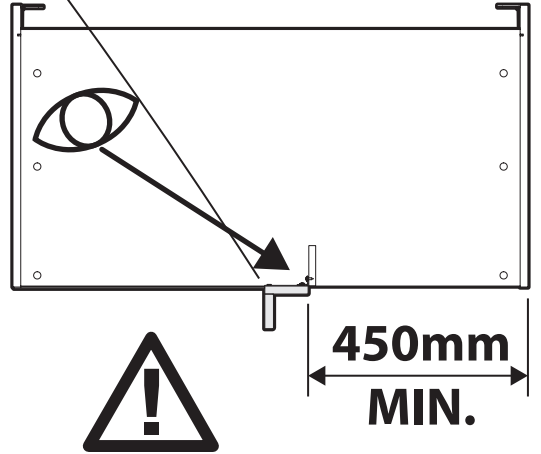
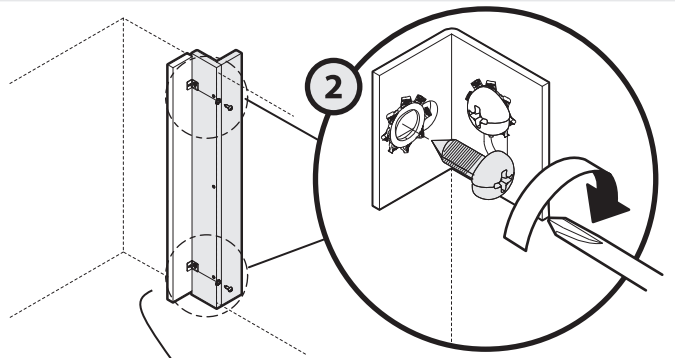
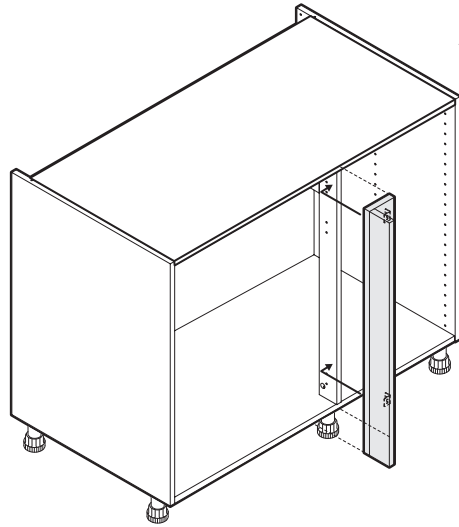
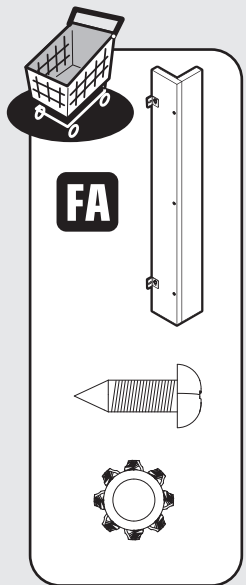
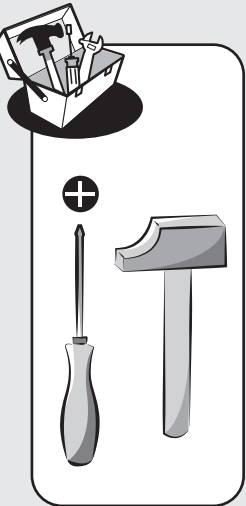
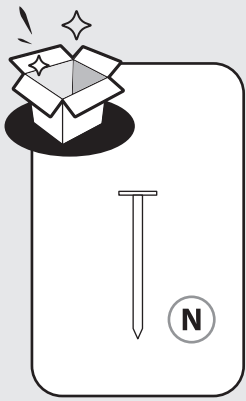

i

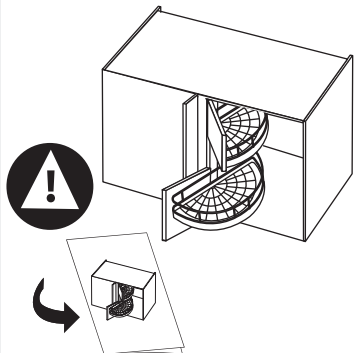
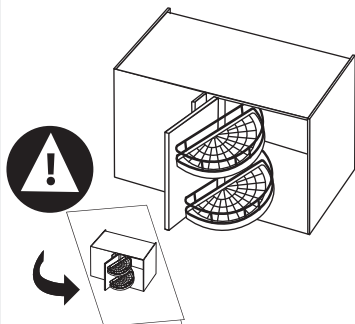
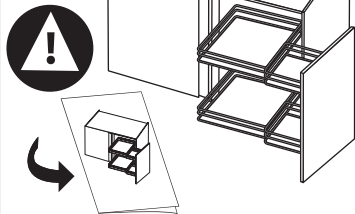

11 A

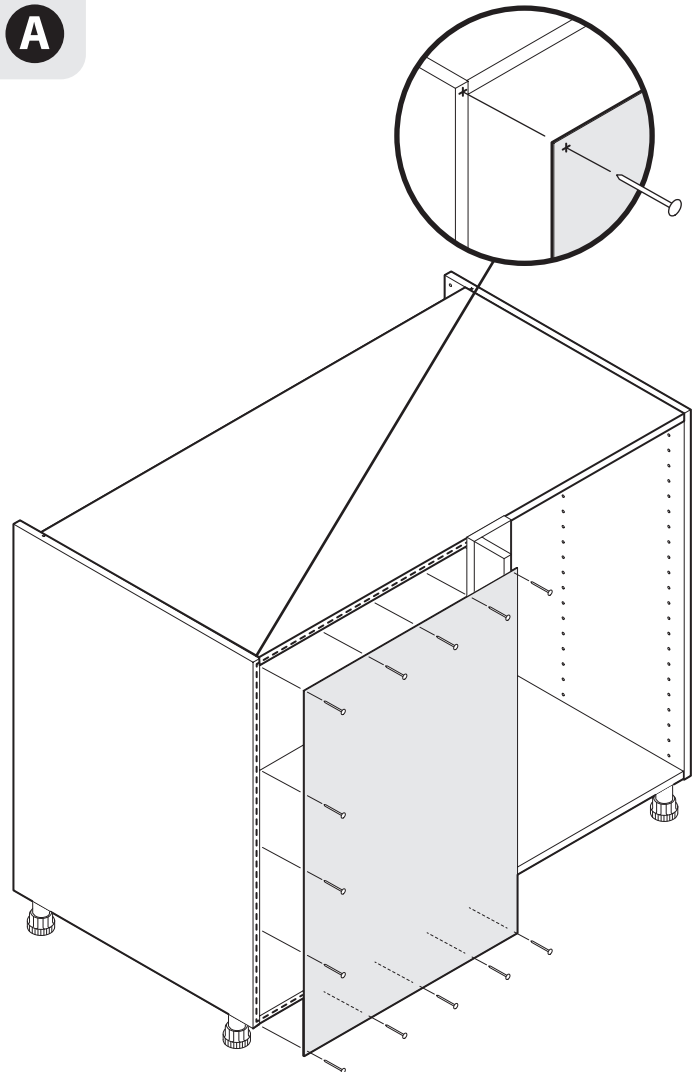

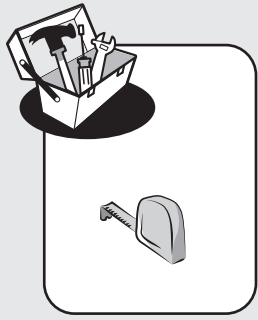

12 A

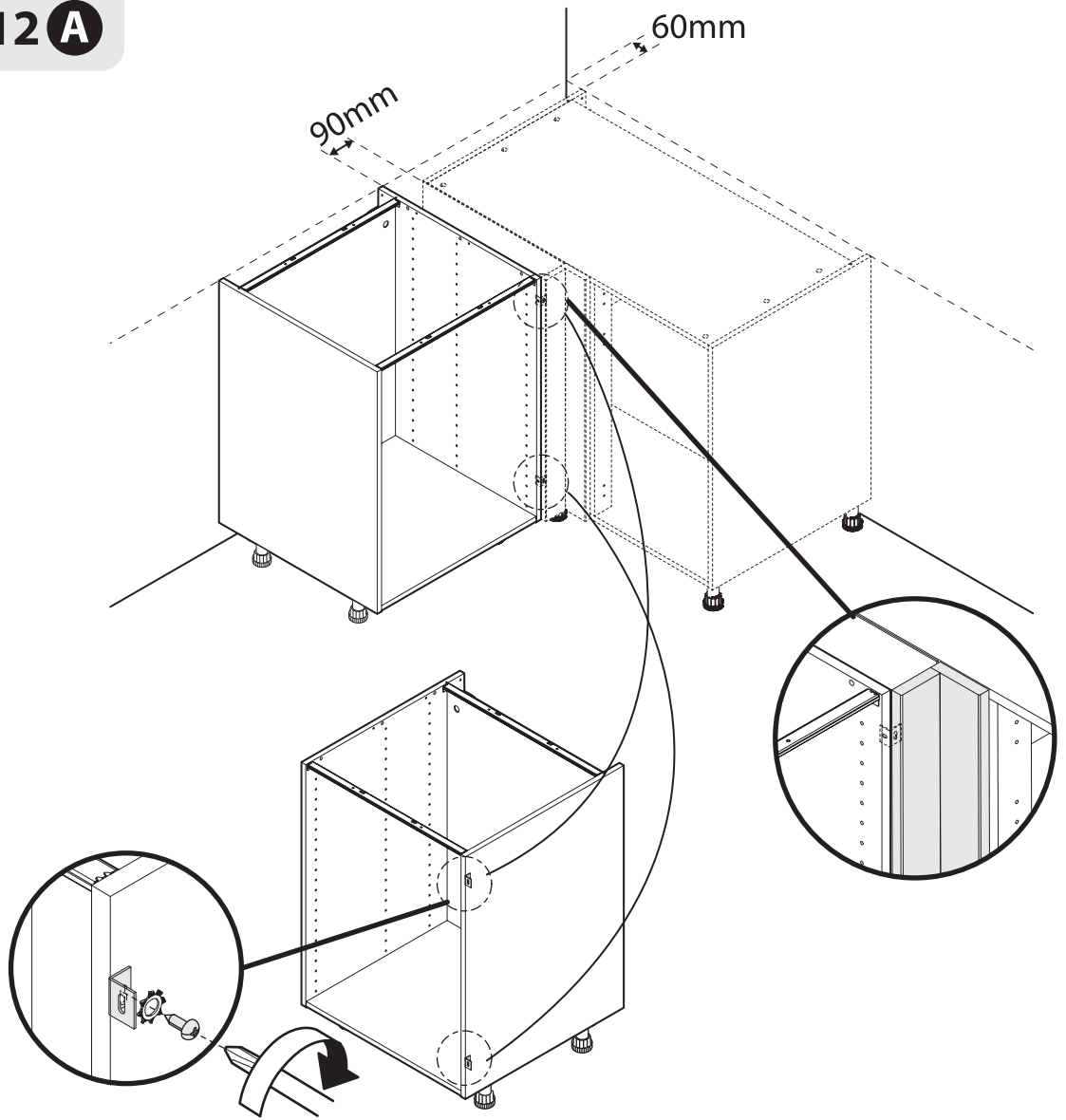

13 A

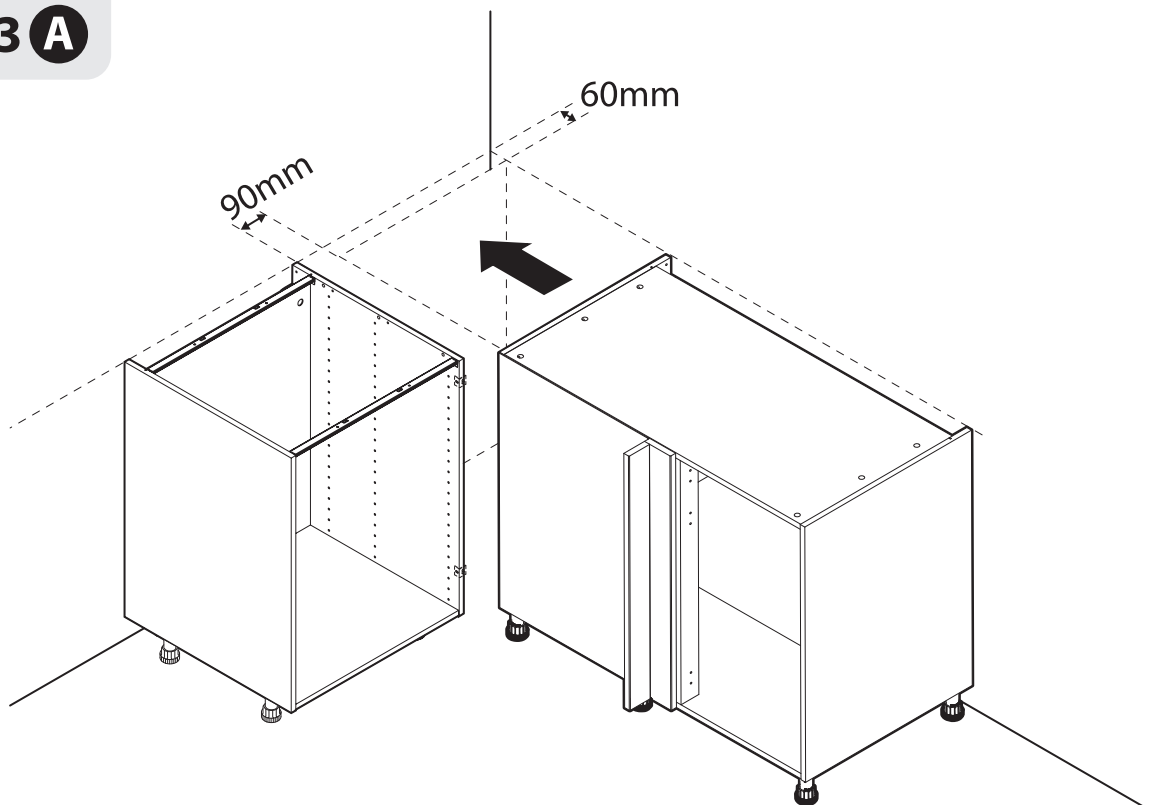

14 A

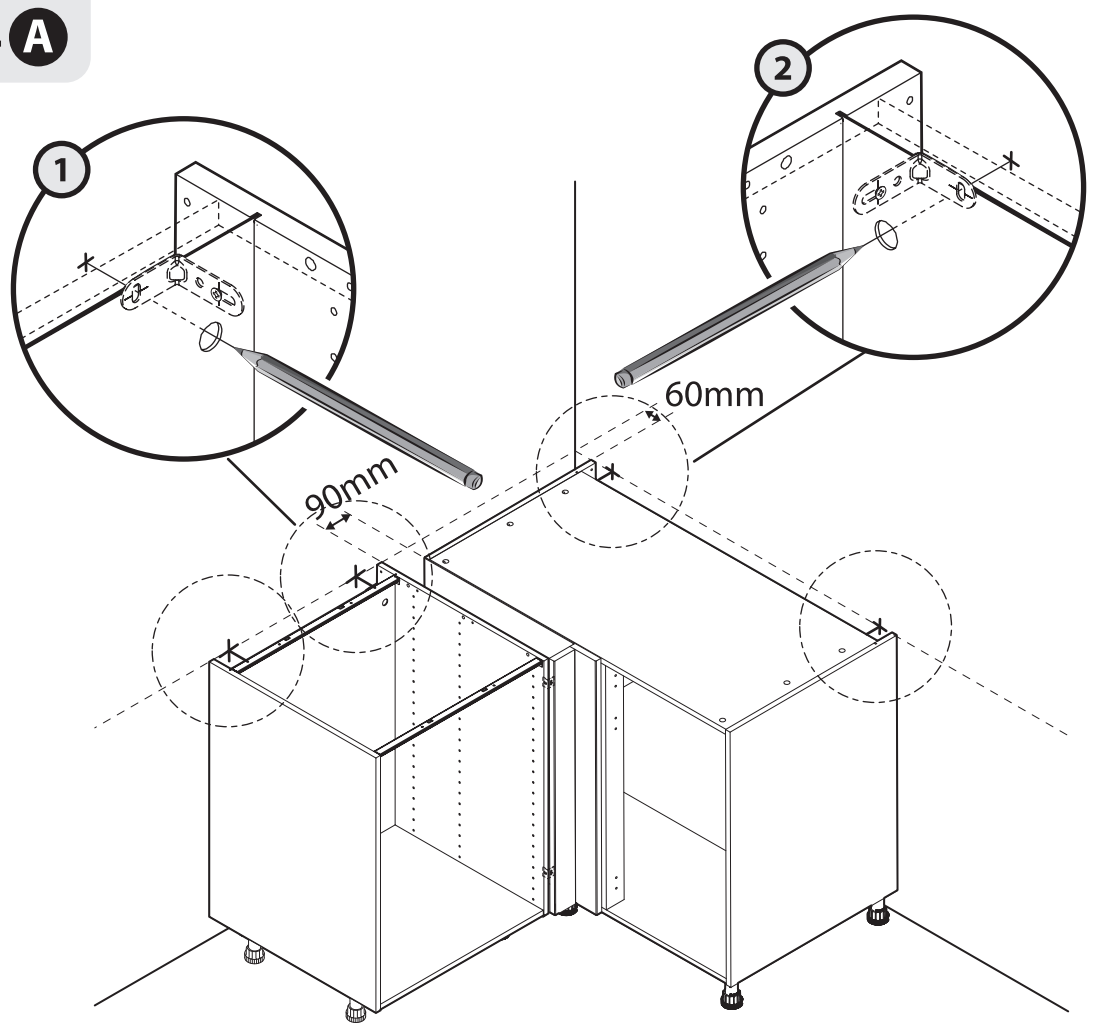
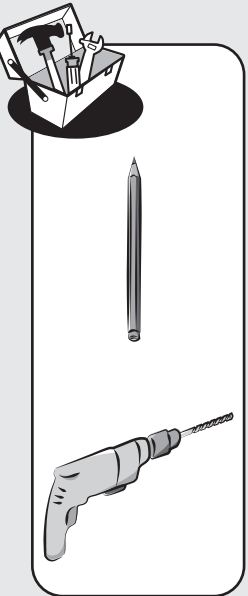
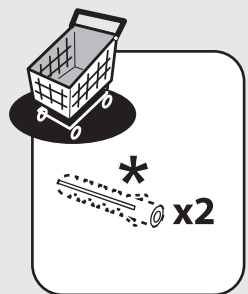

15 A

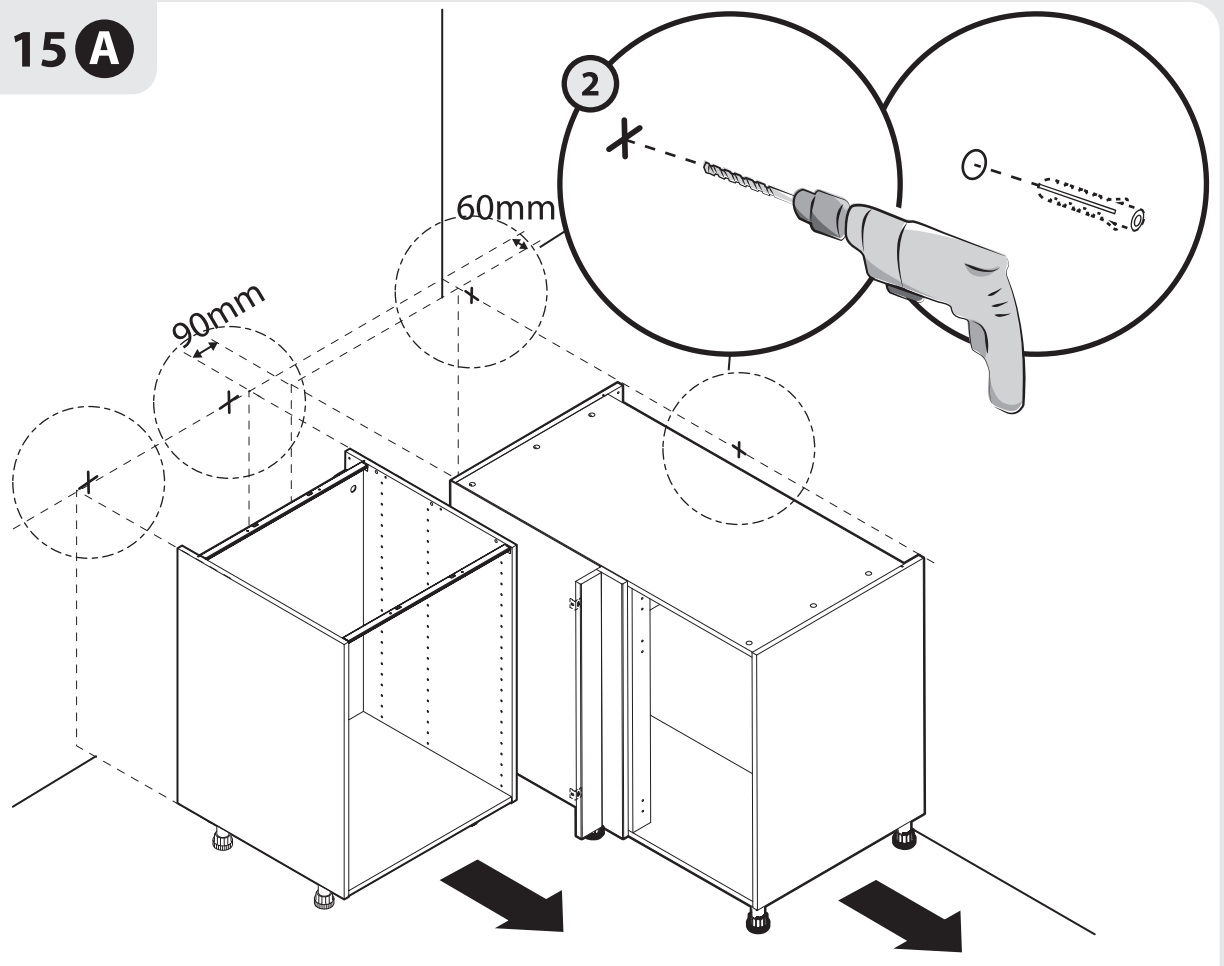

16 A

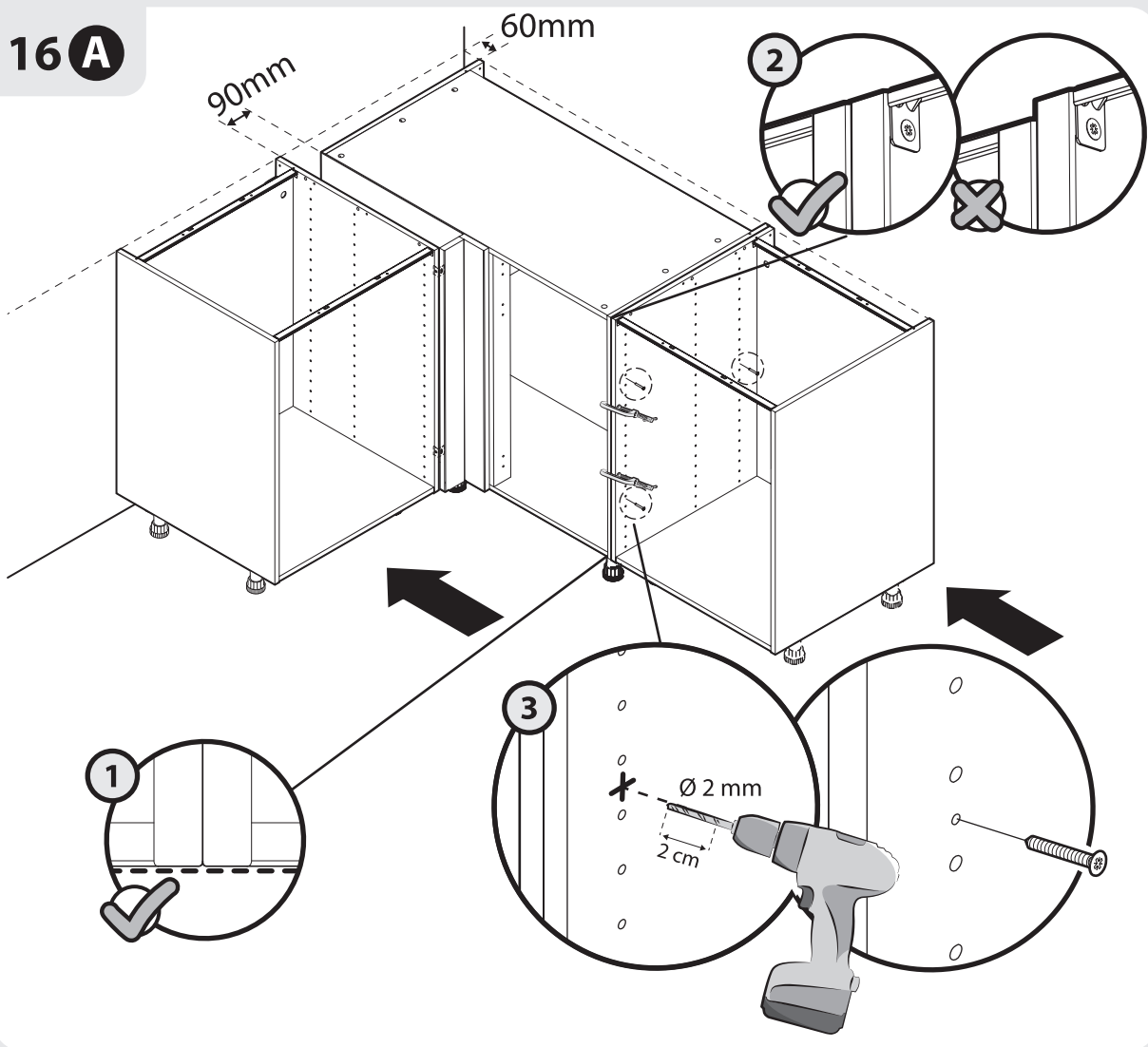

+

J

x3

4x25/30

o

x2

*

x9

Ø 2 mm

17 A

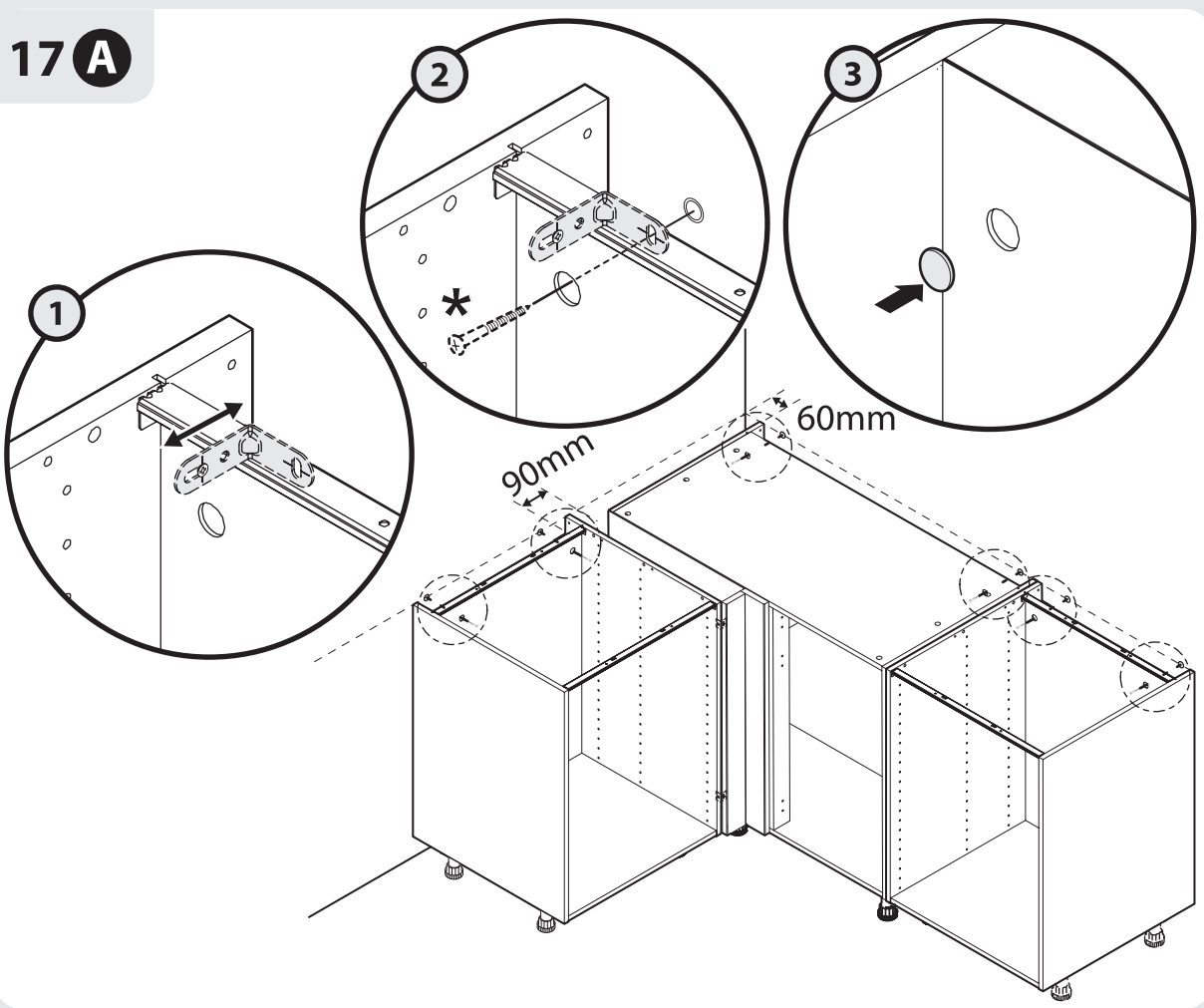

18 **A**

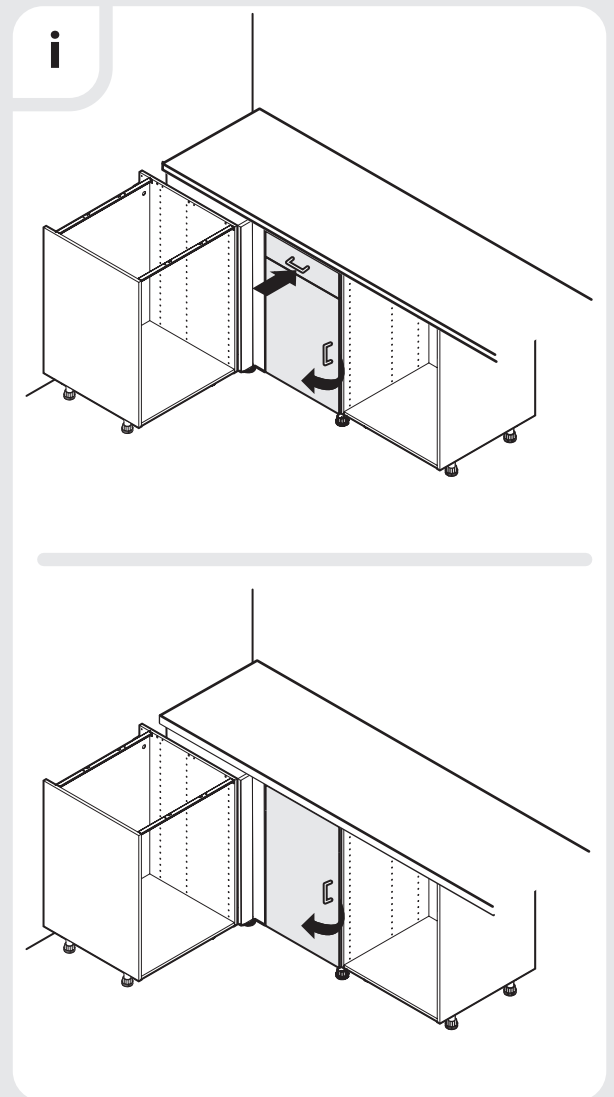
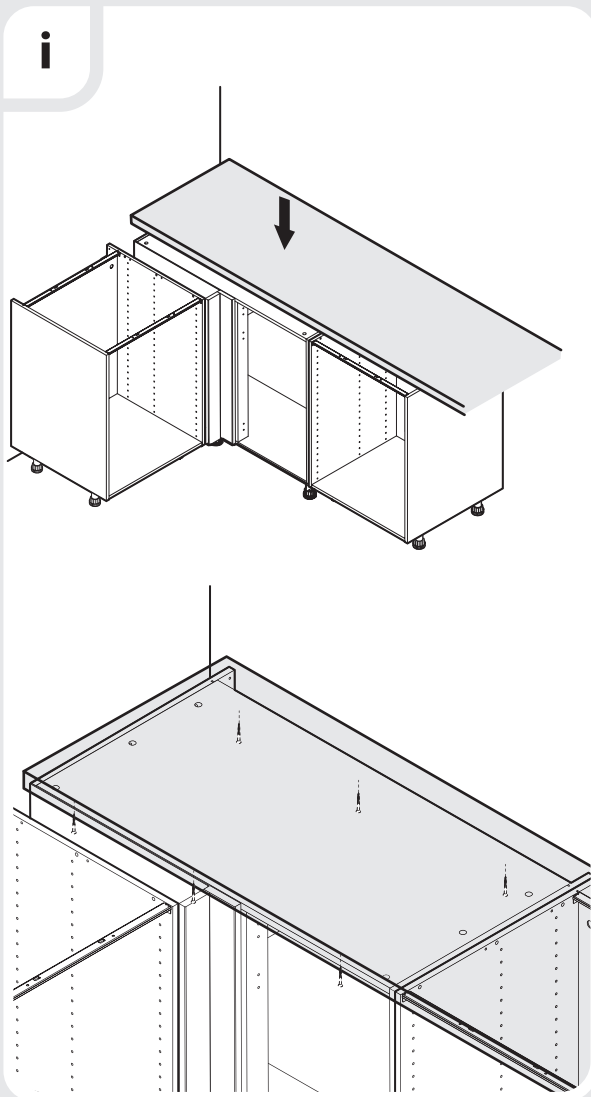
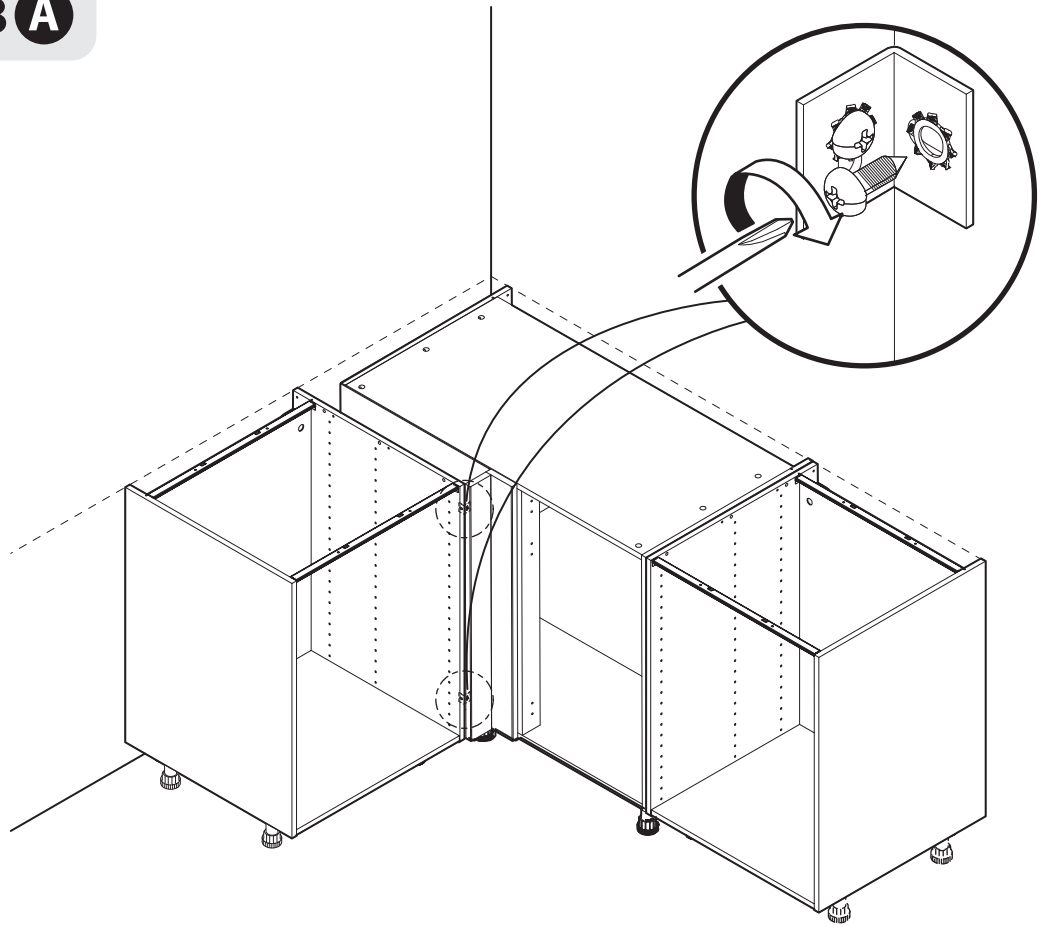
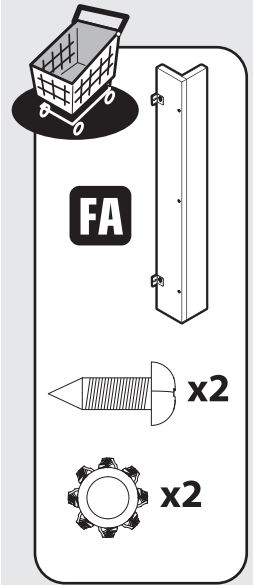
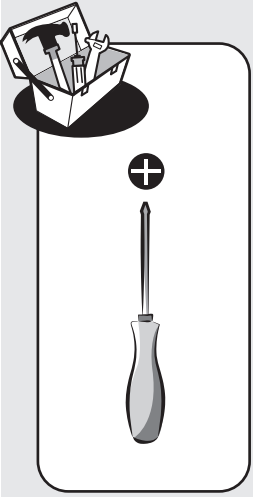

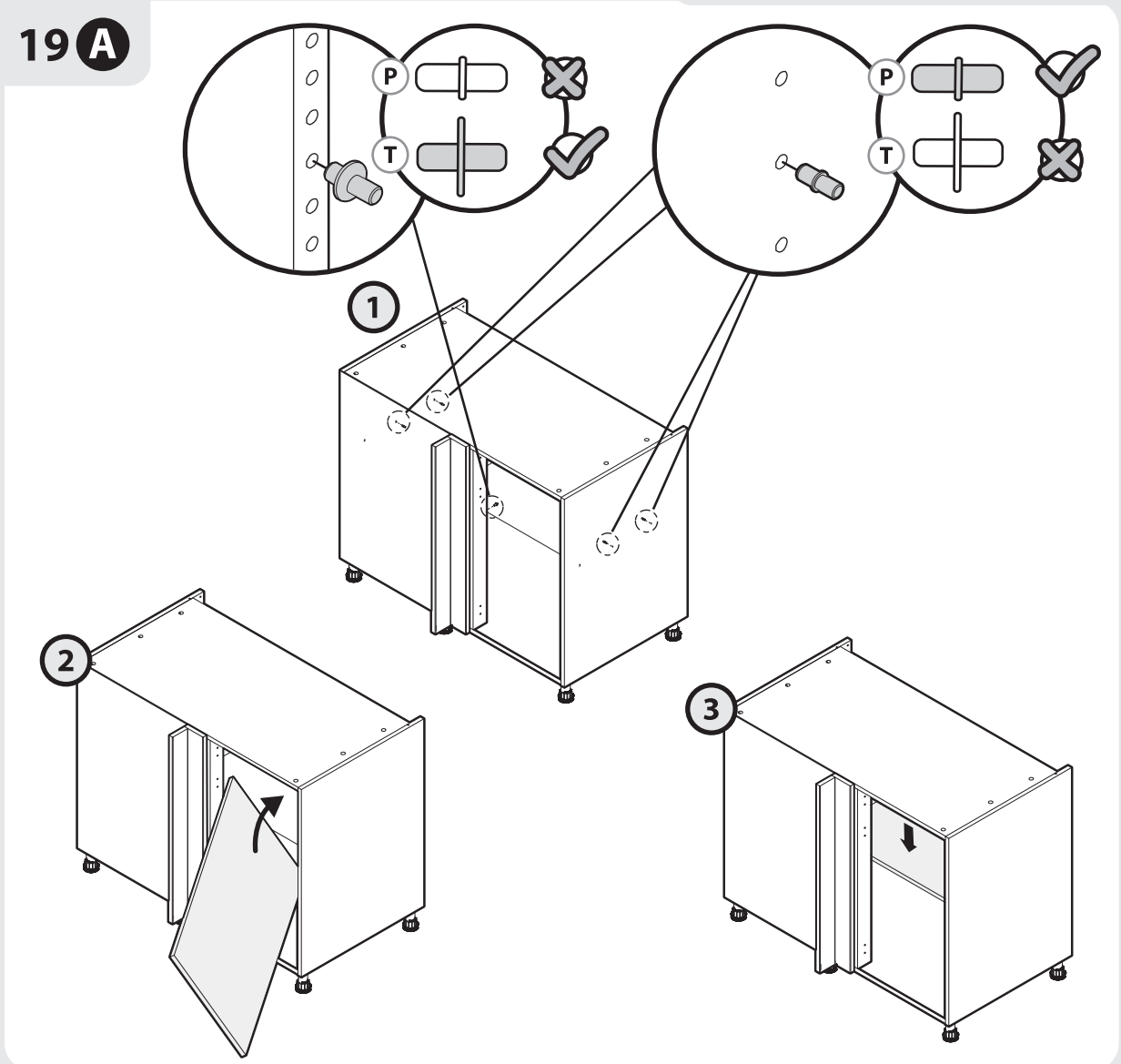
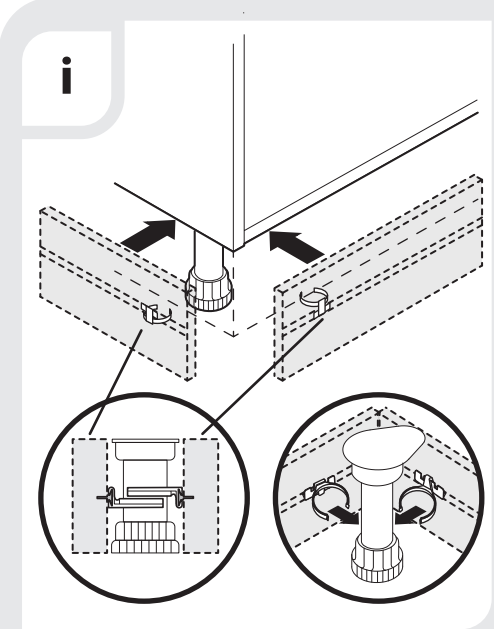
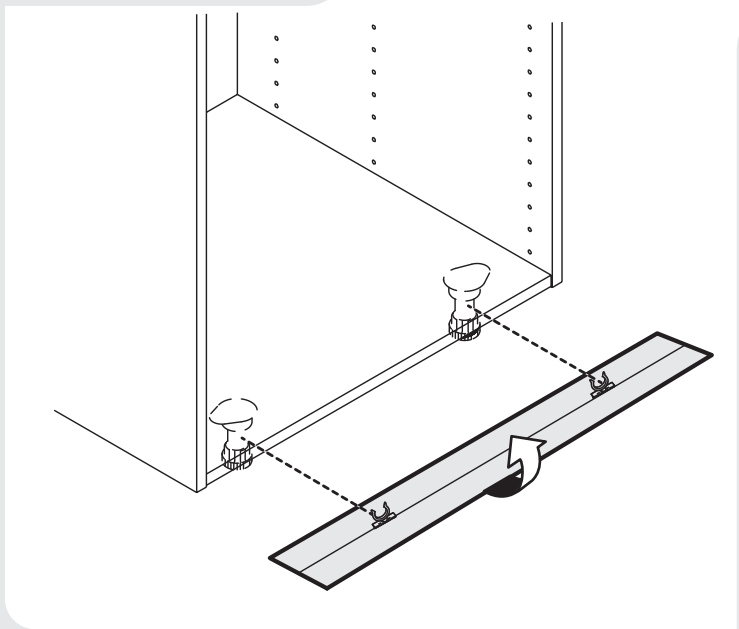
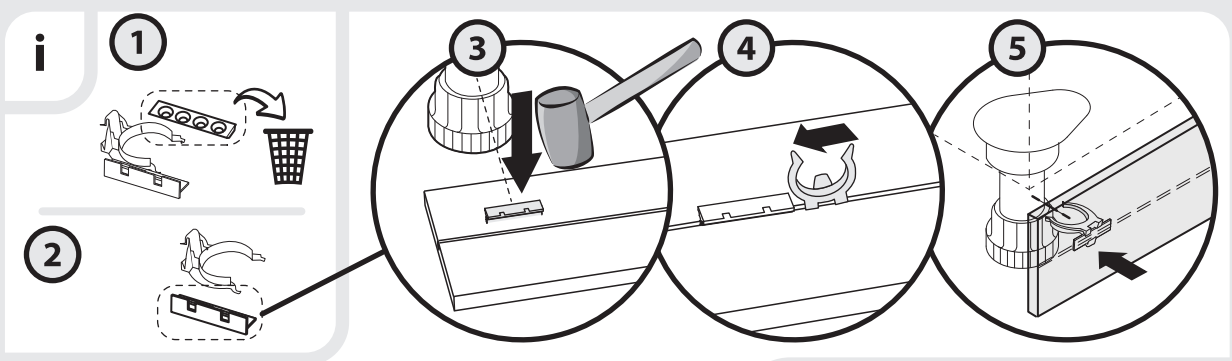
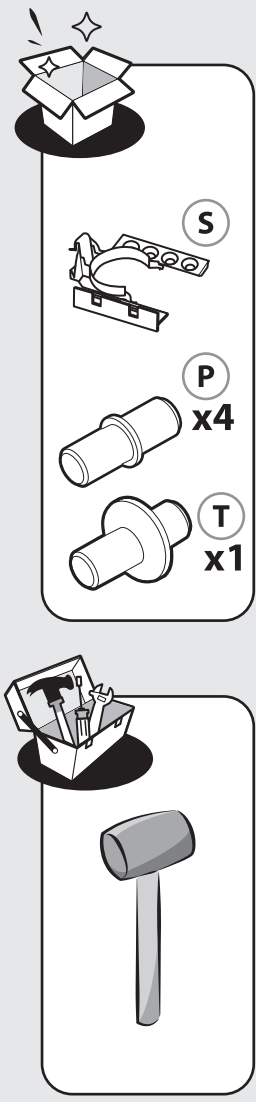



K
x12

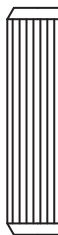

L
x12



I
x2



R
x2



B

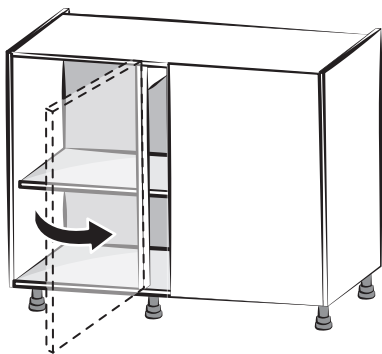

1 B

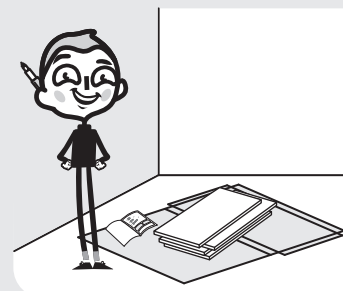
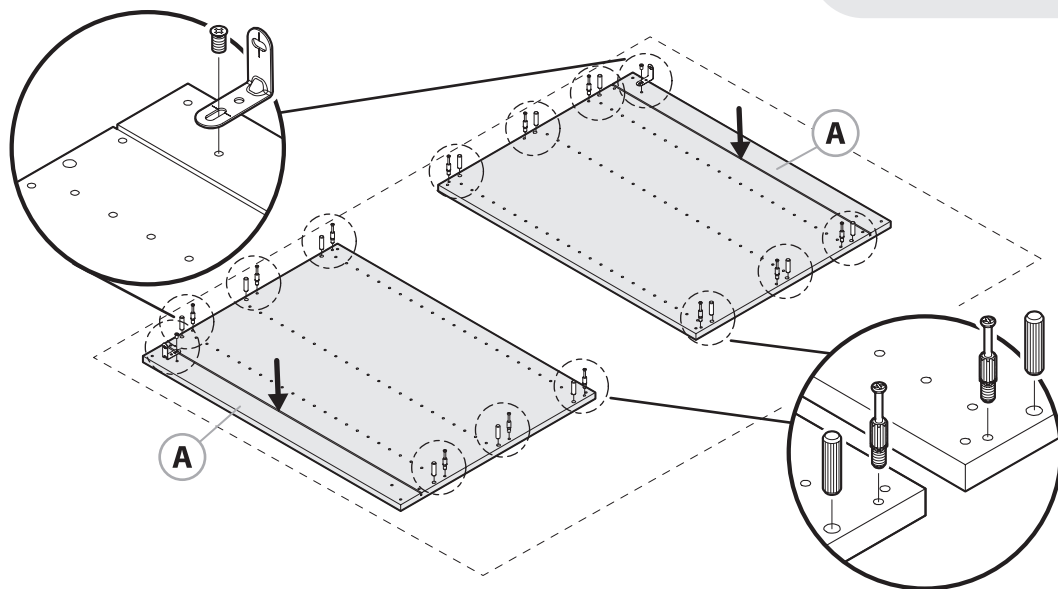

2 B

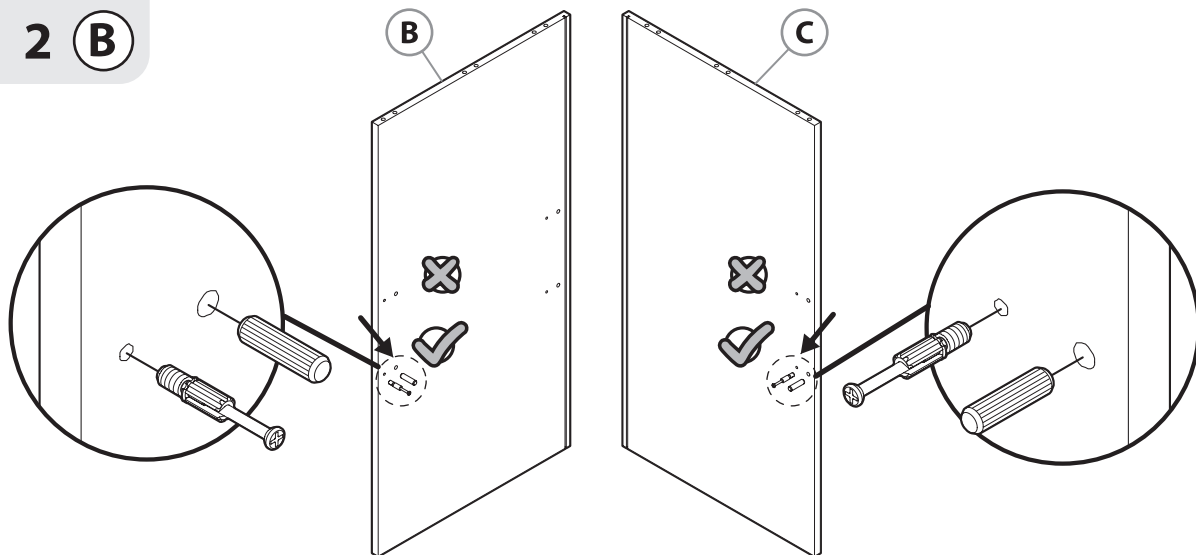

i

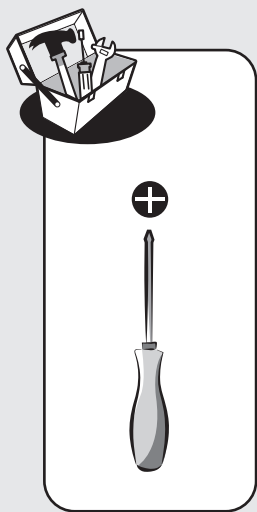
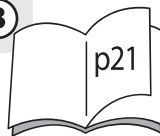
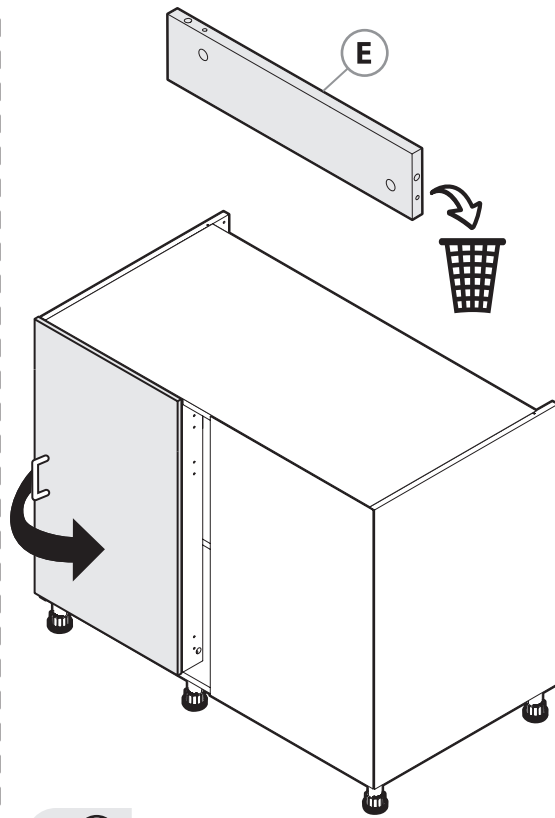
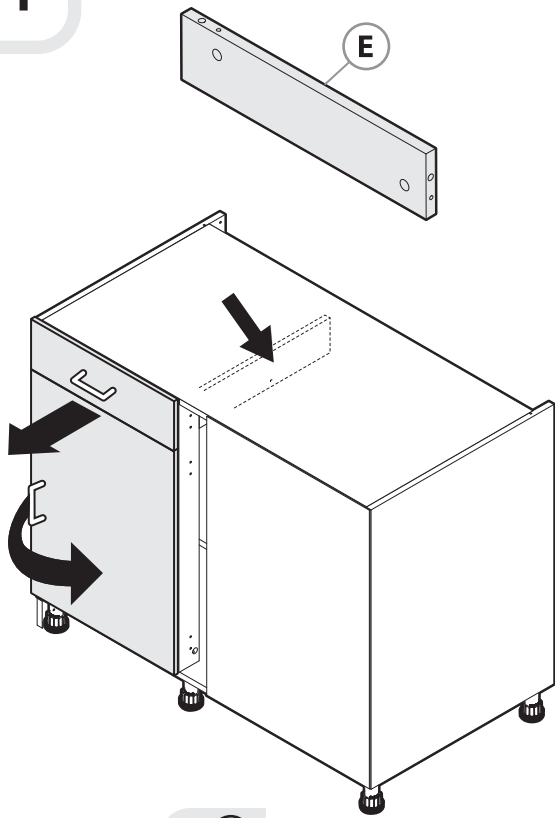
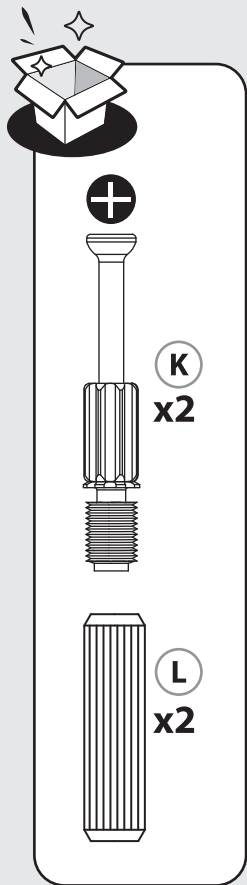

3 B

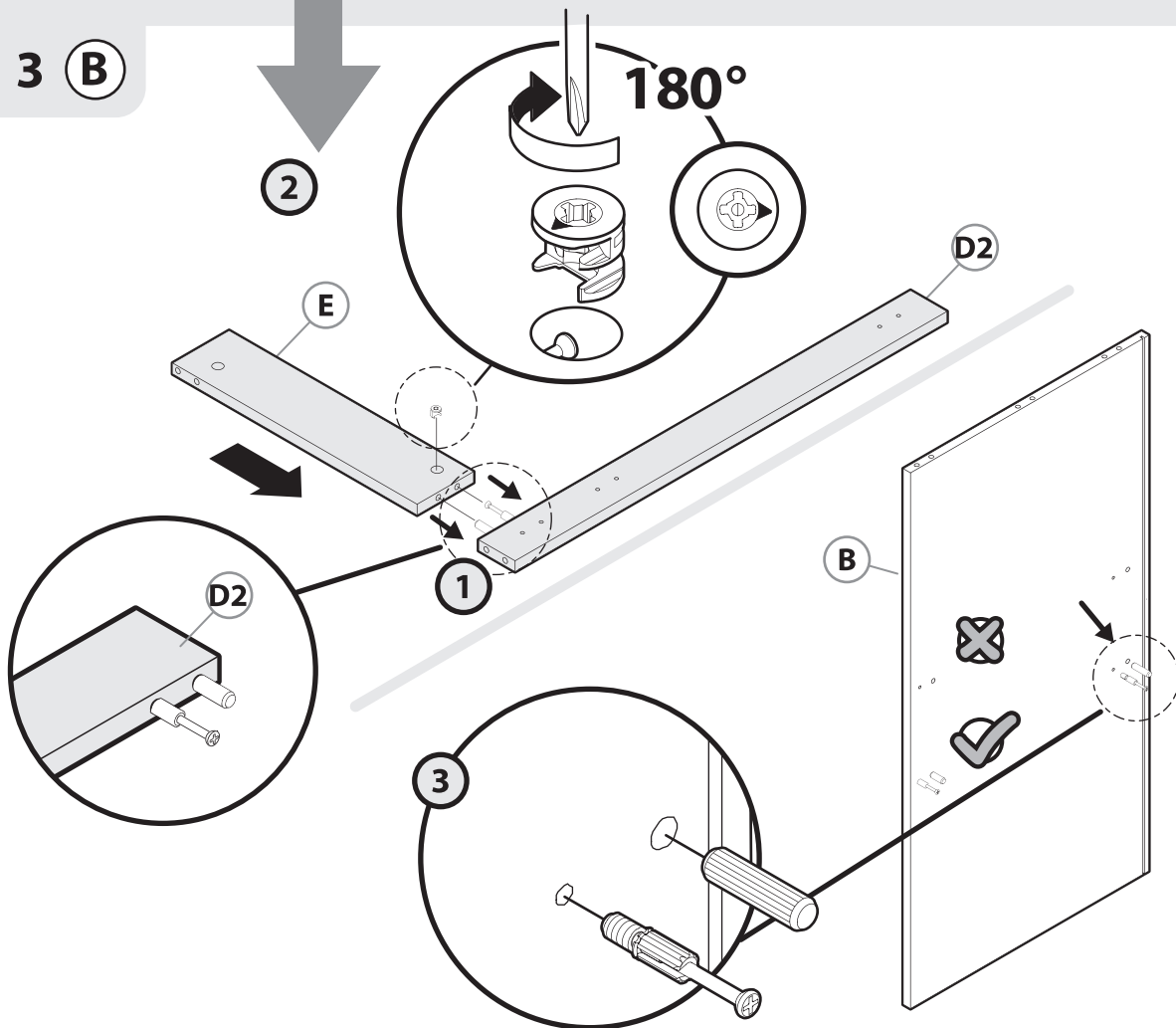

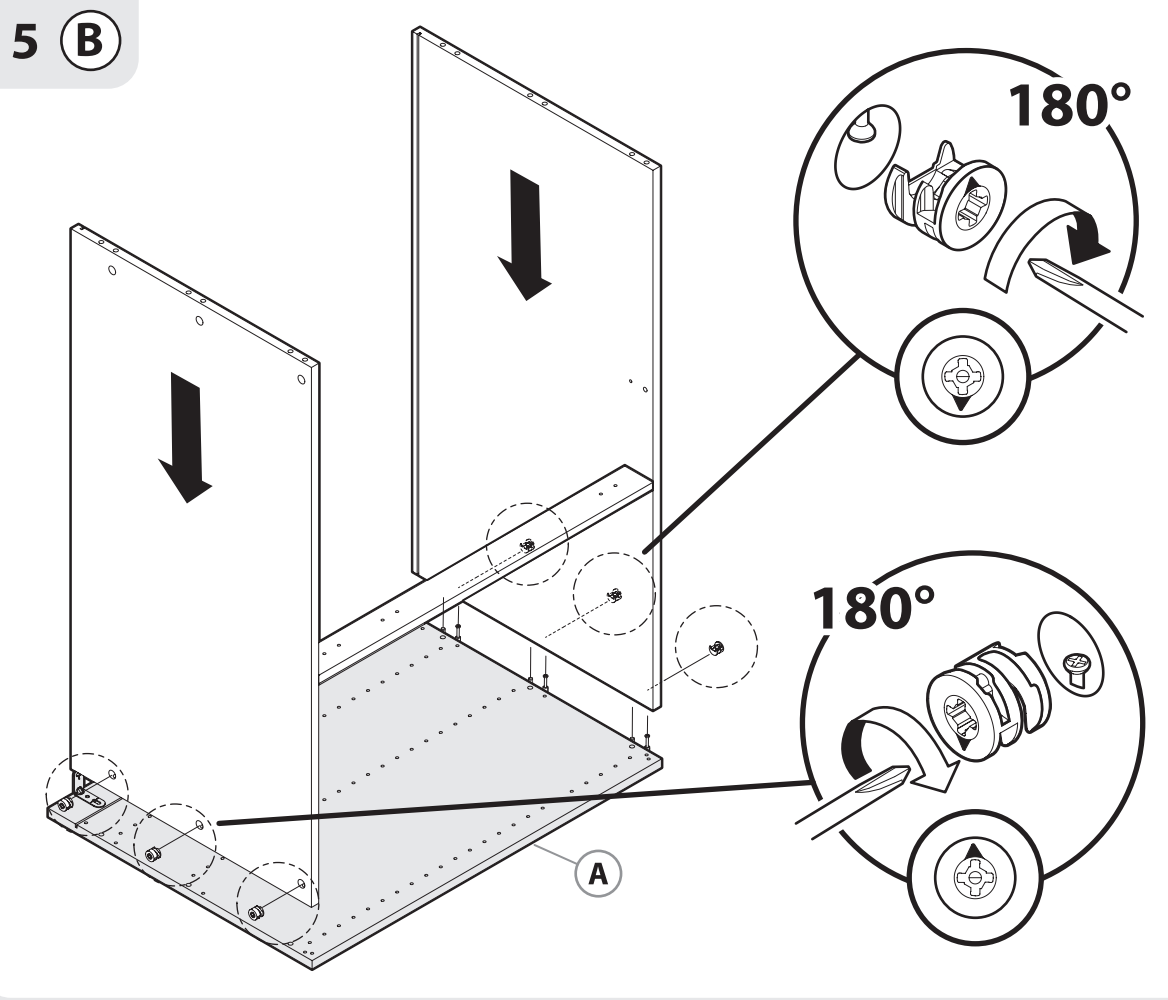
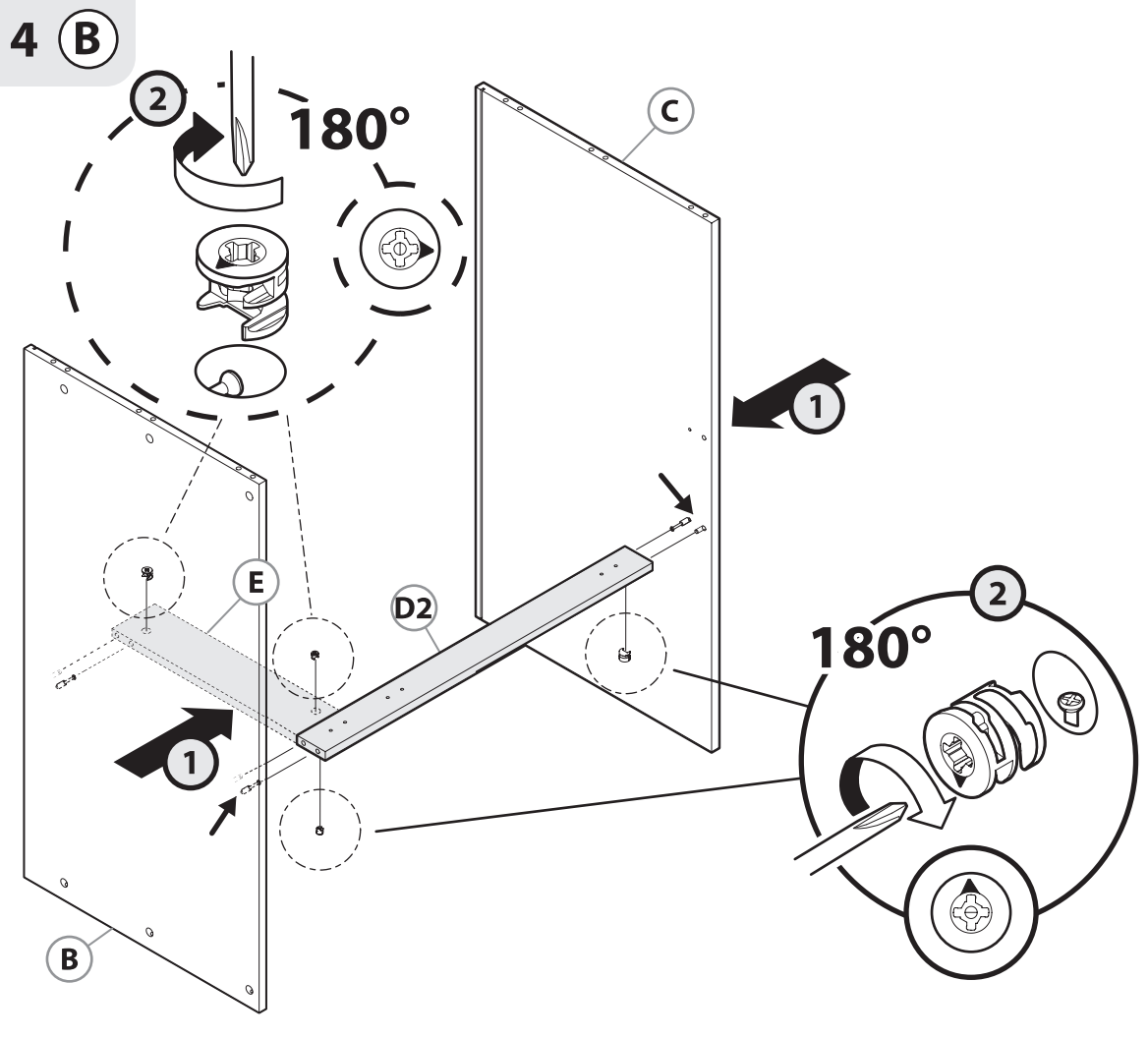
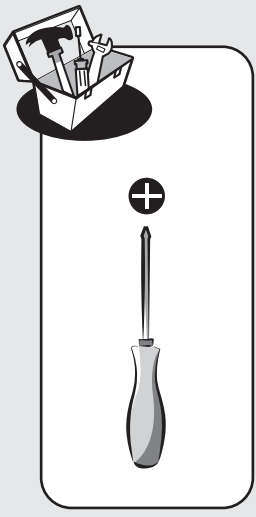
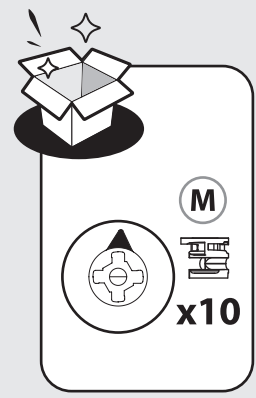

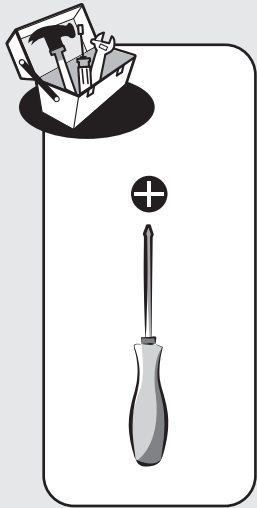
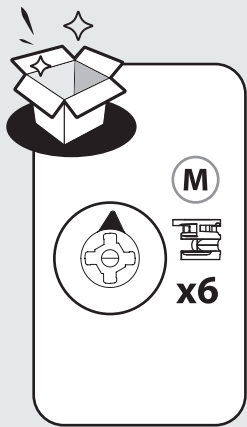

6 (B)

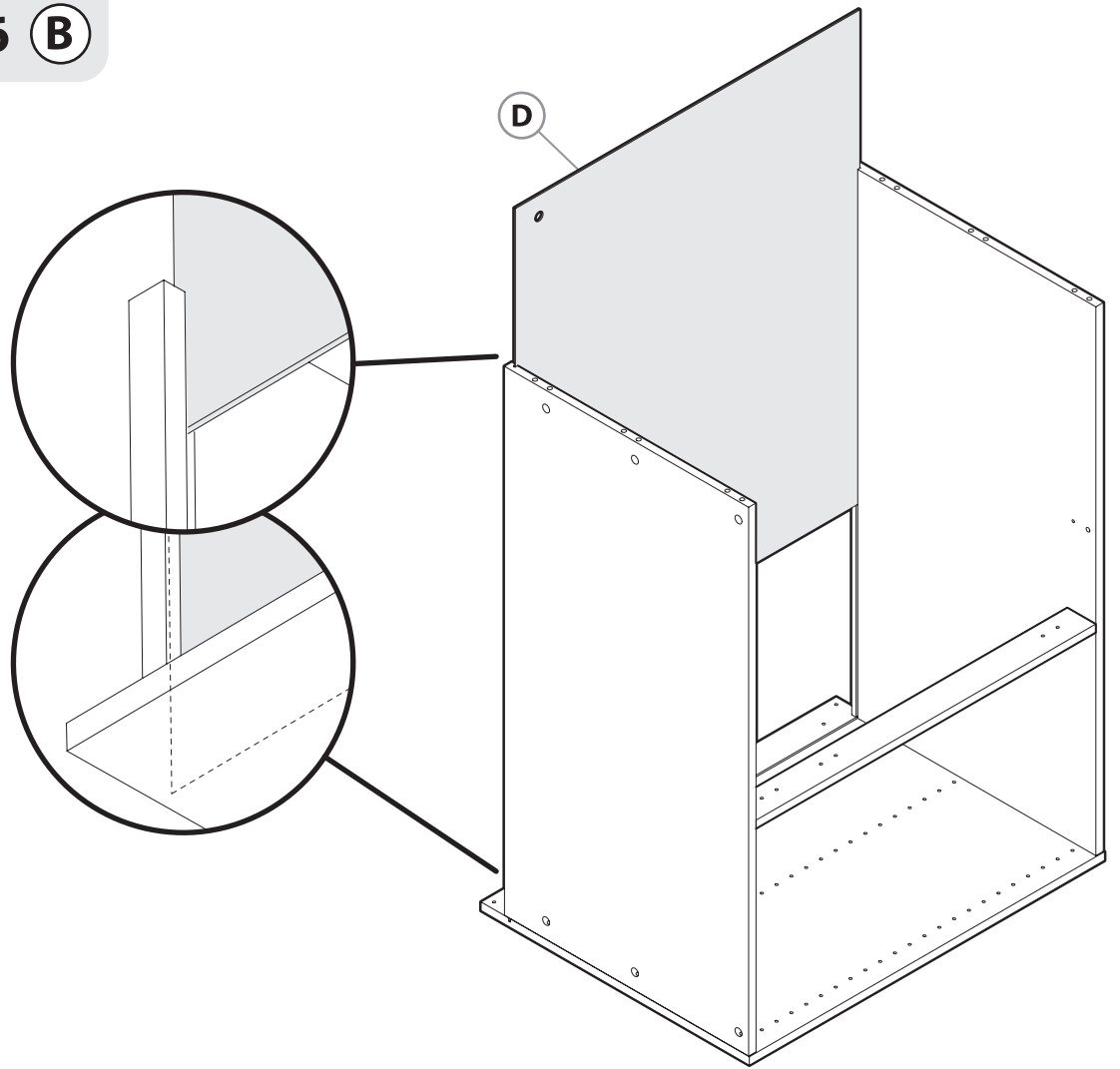

7 (B)

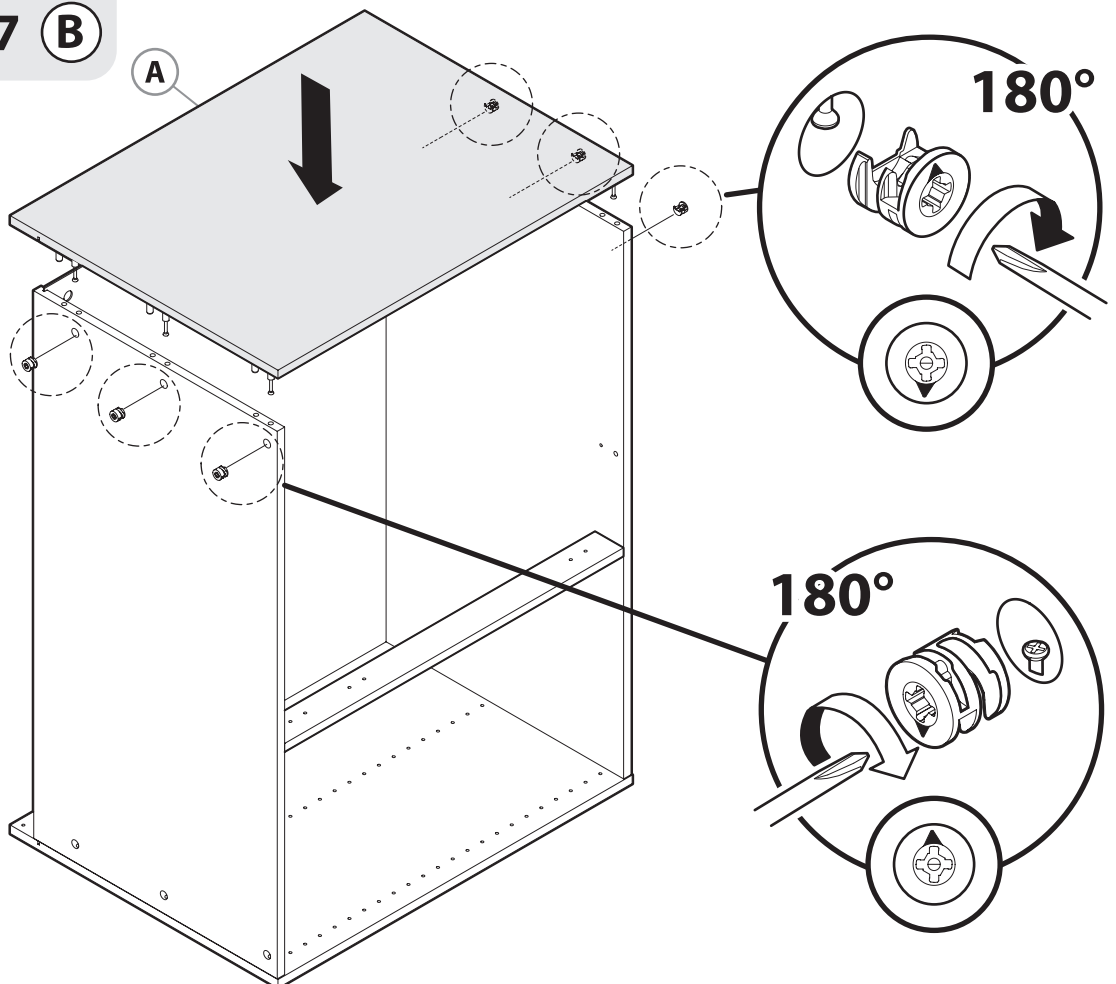

8 **B**



M



x6



Q

x12



+

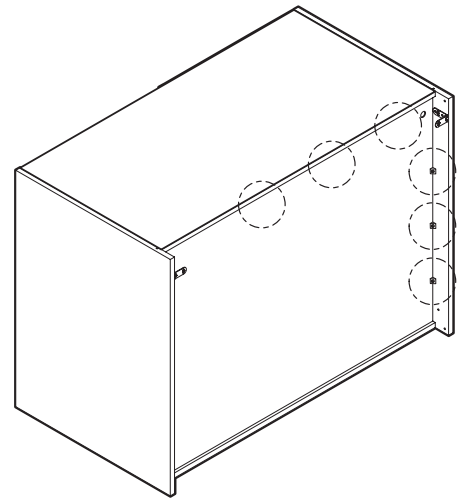
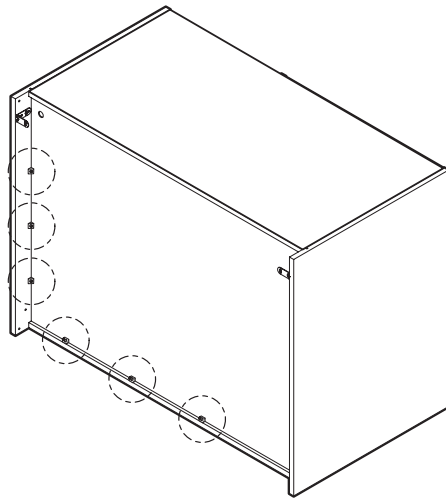
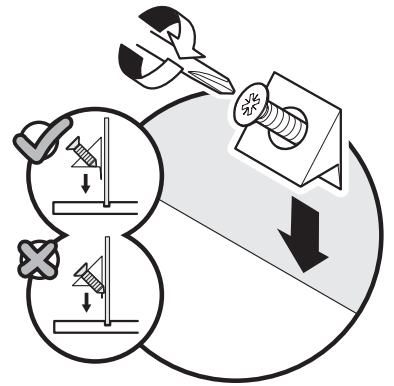
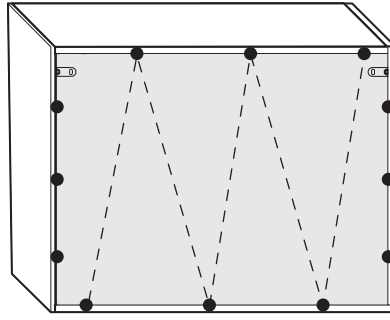

i

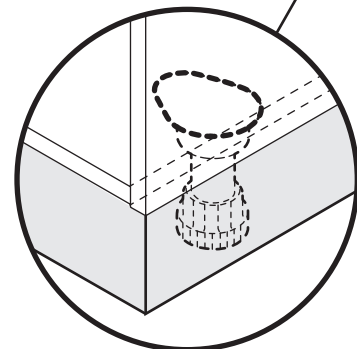
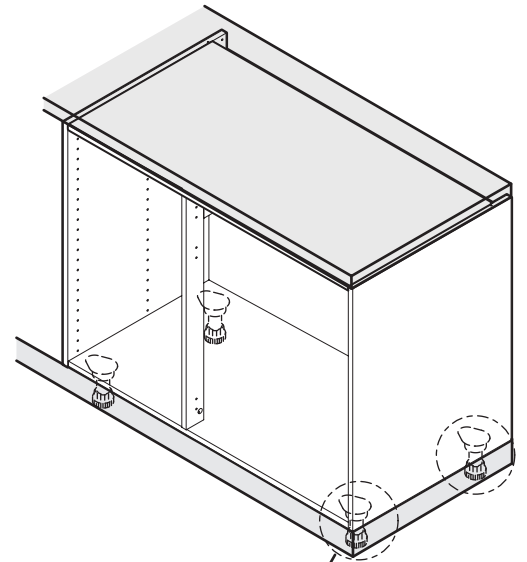
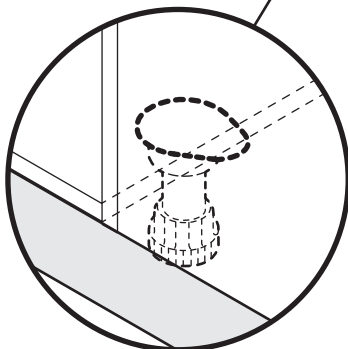
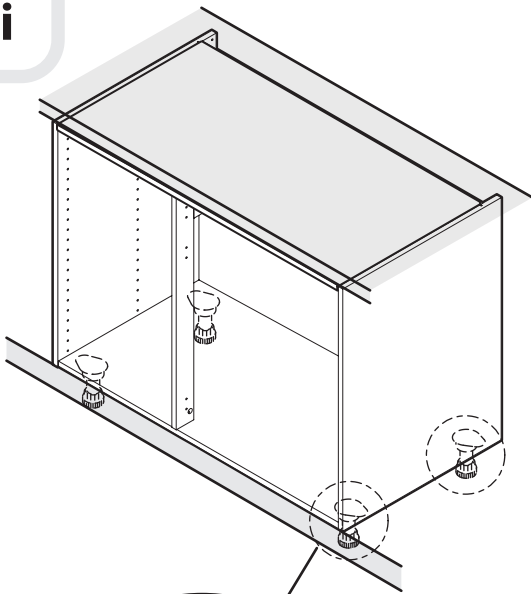

9 (B)

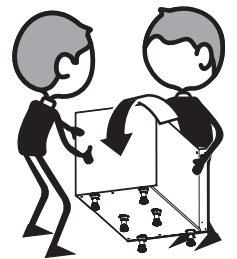
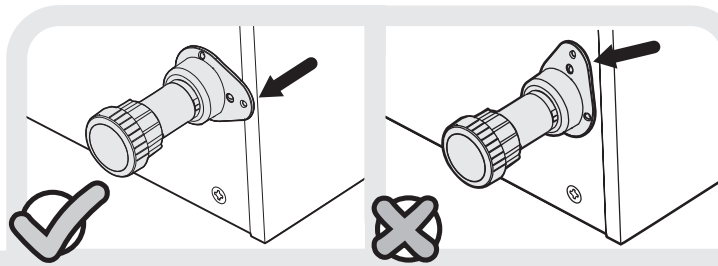
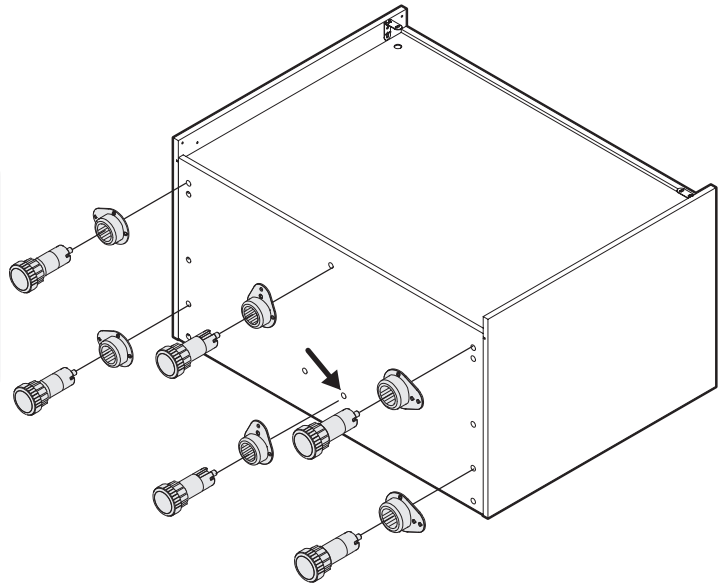
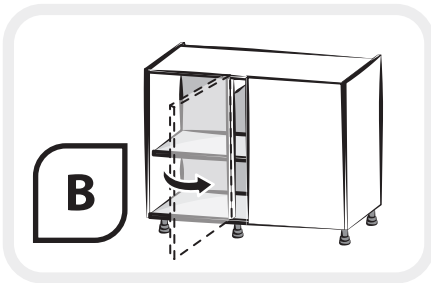
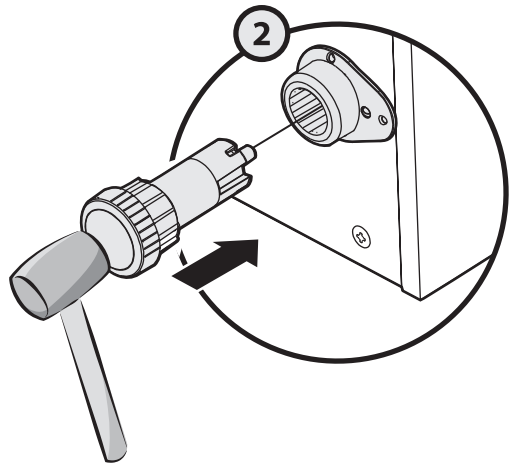
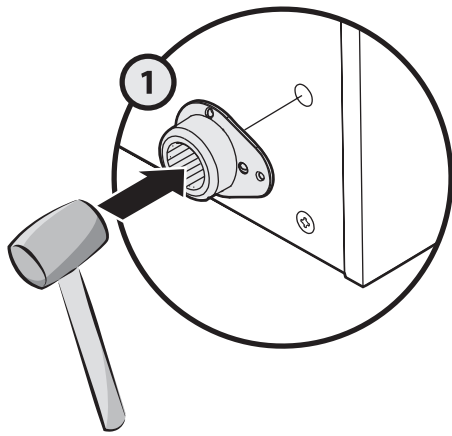
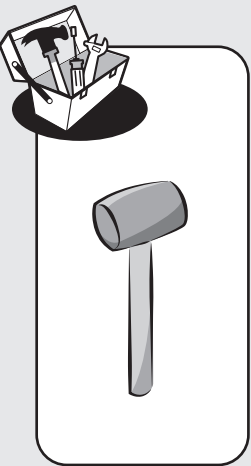
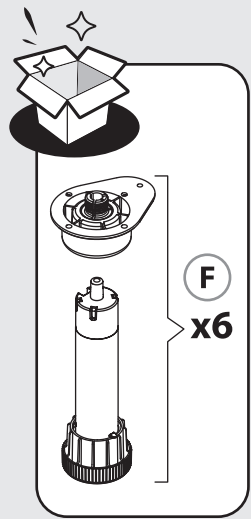

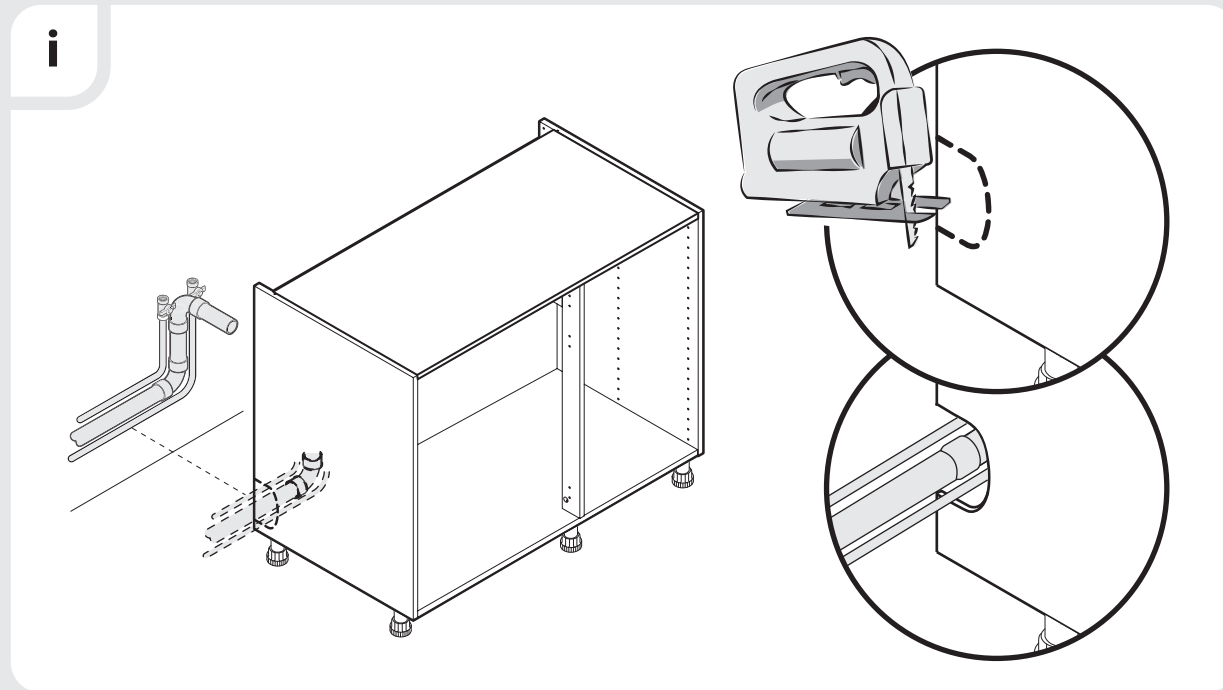
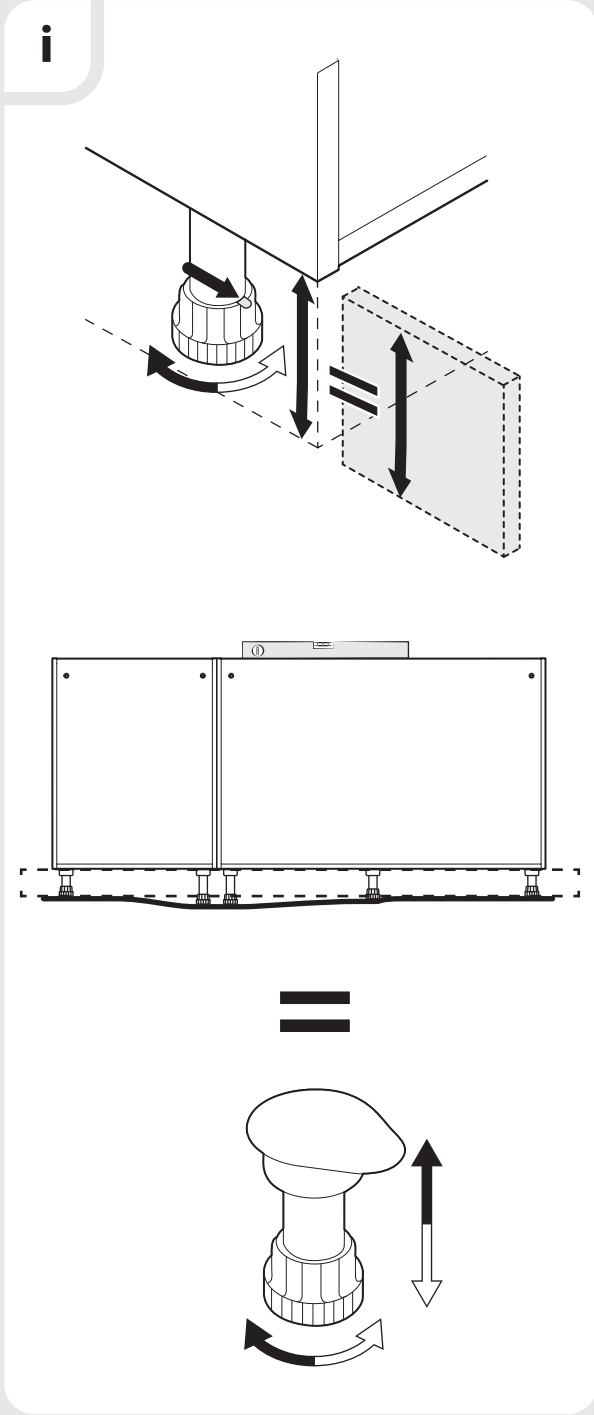
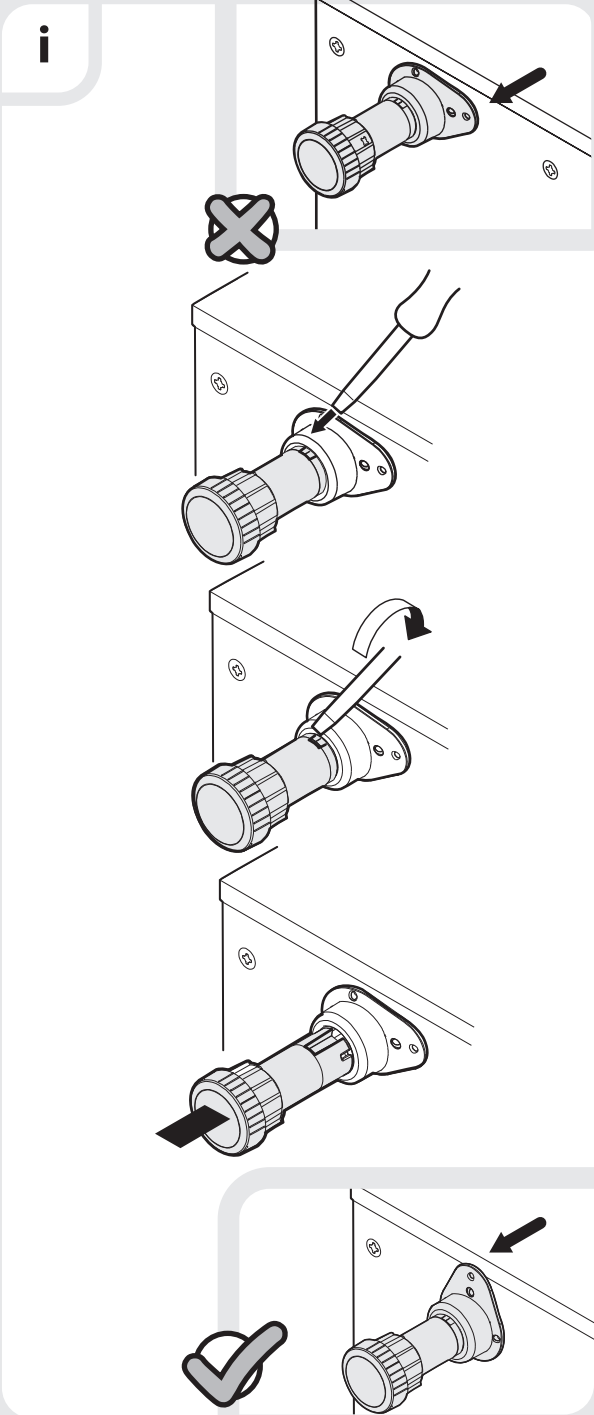
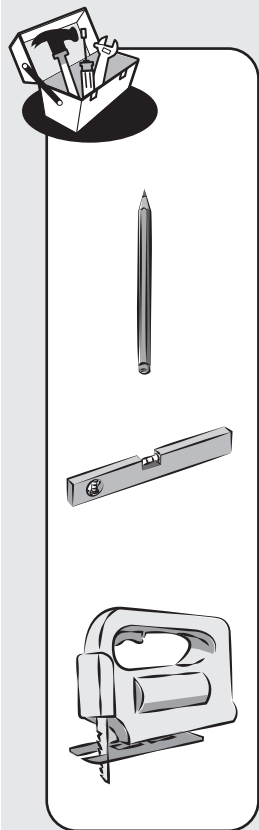

10 (B)

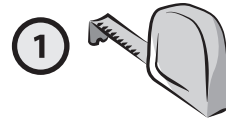
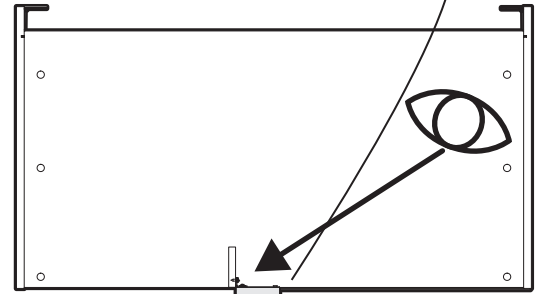
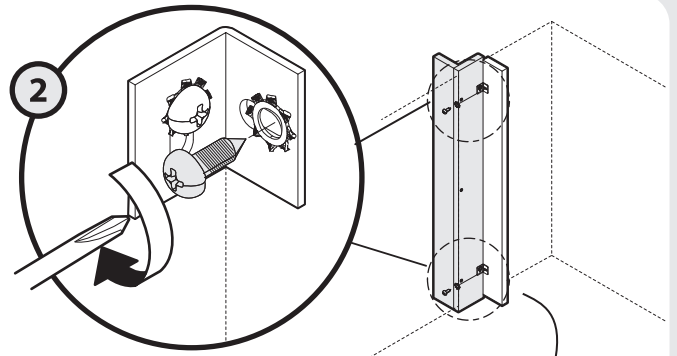
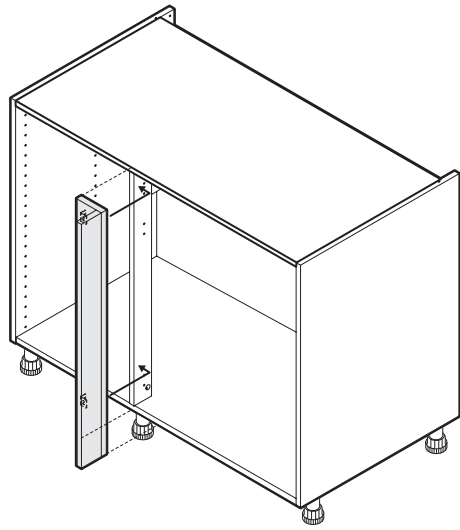
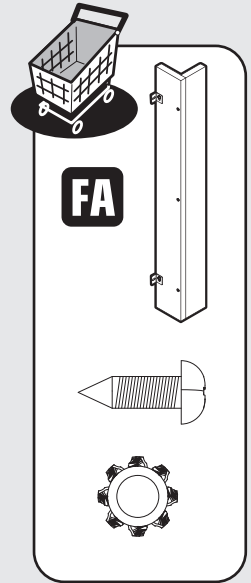
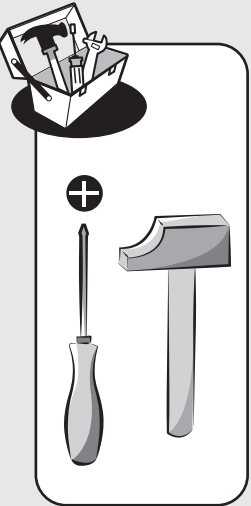
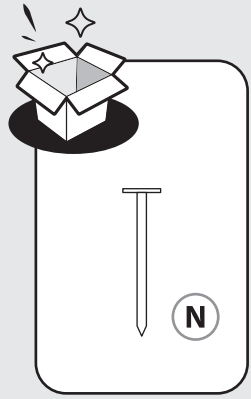

i

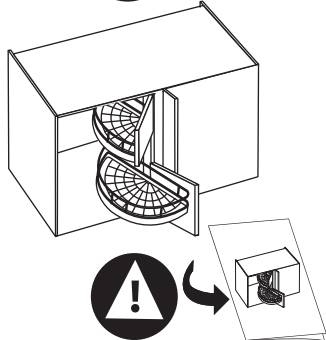
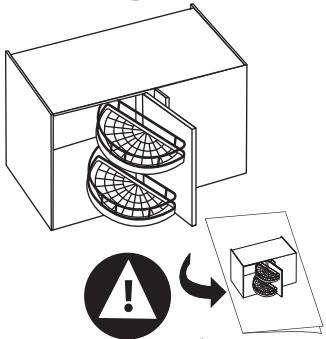
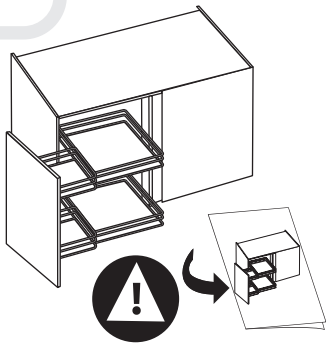

11 (B)

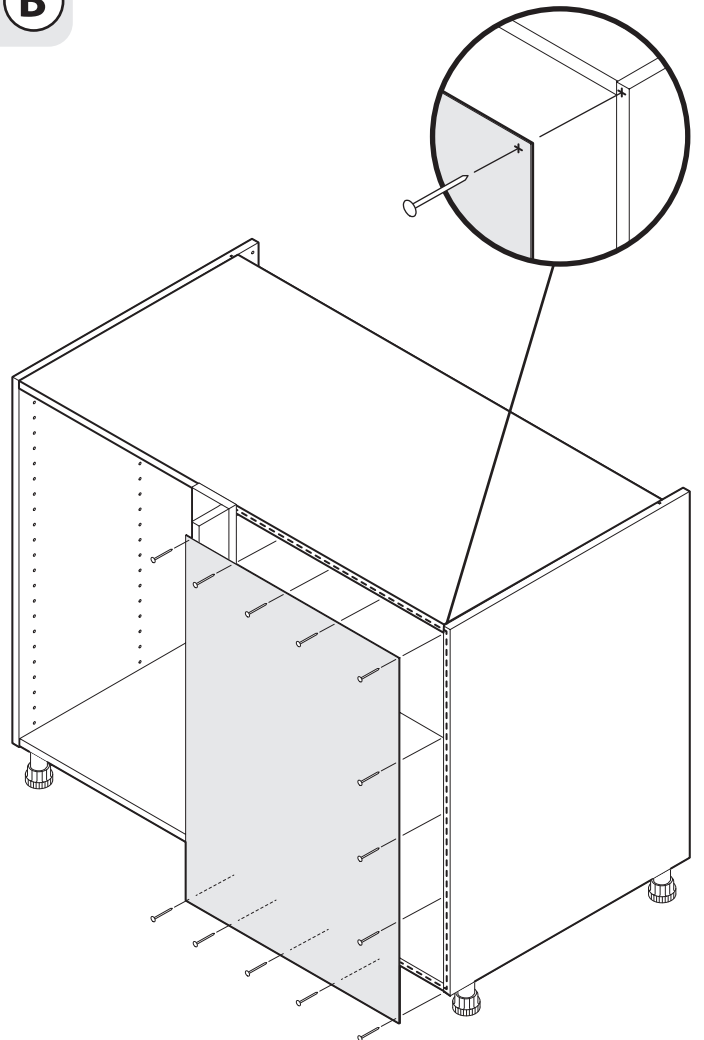

12 (B)

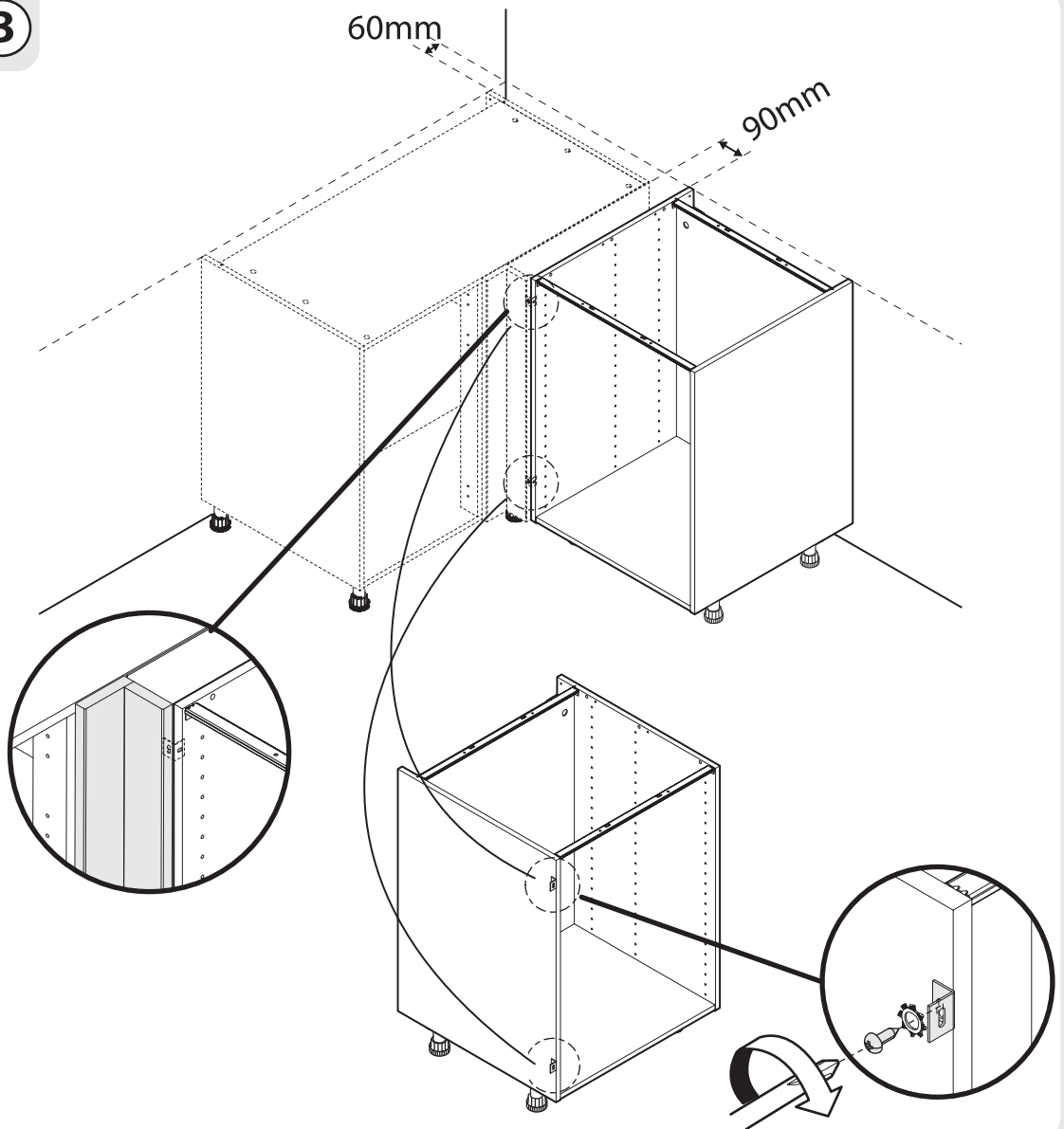
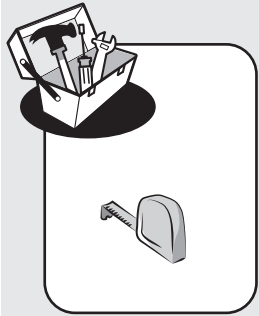

13 (B)

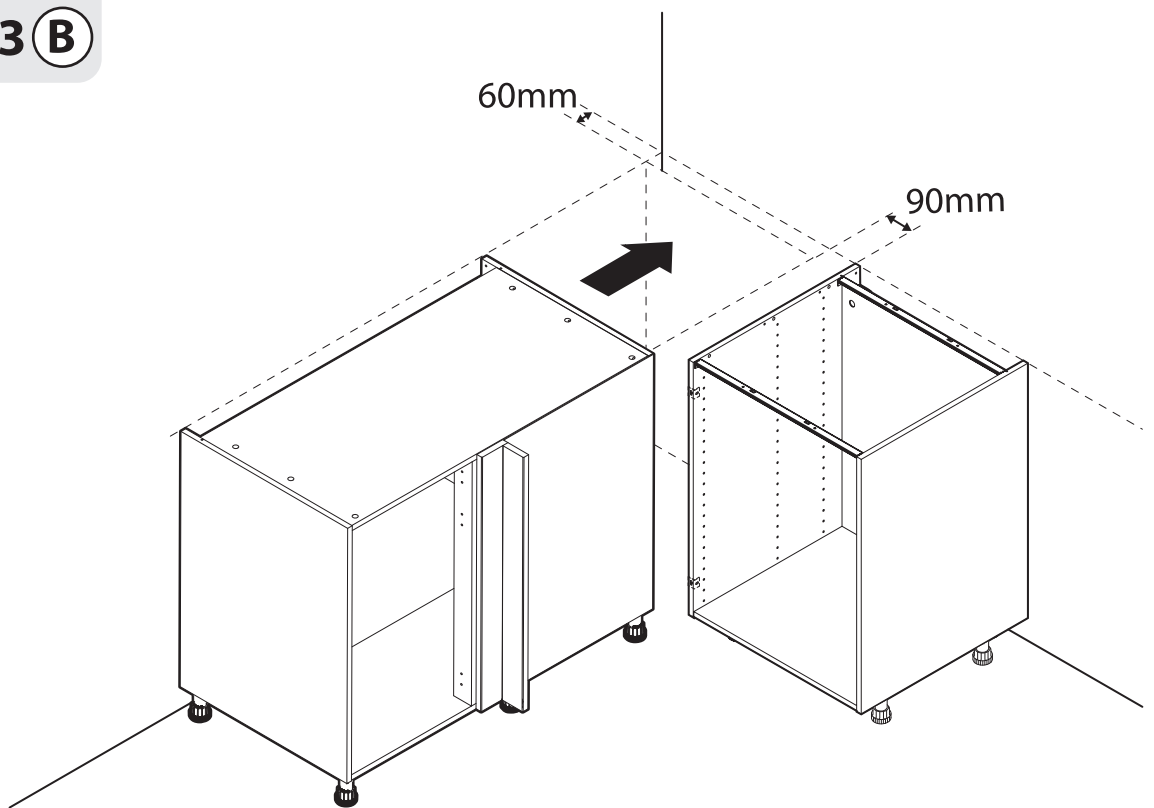

14 (B)



* x2

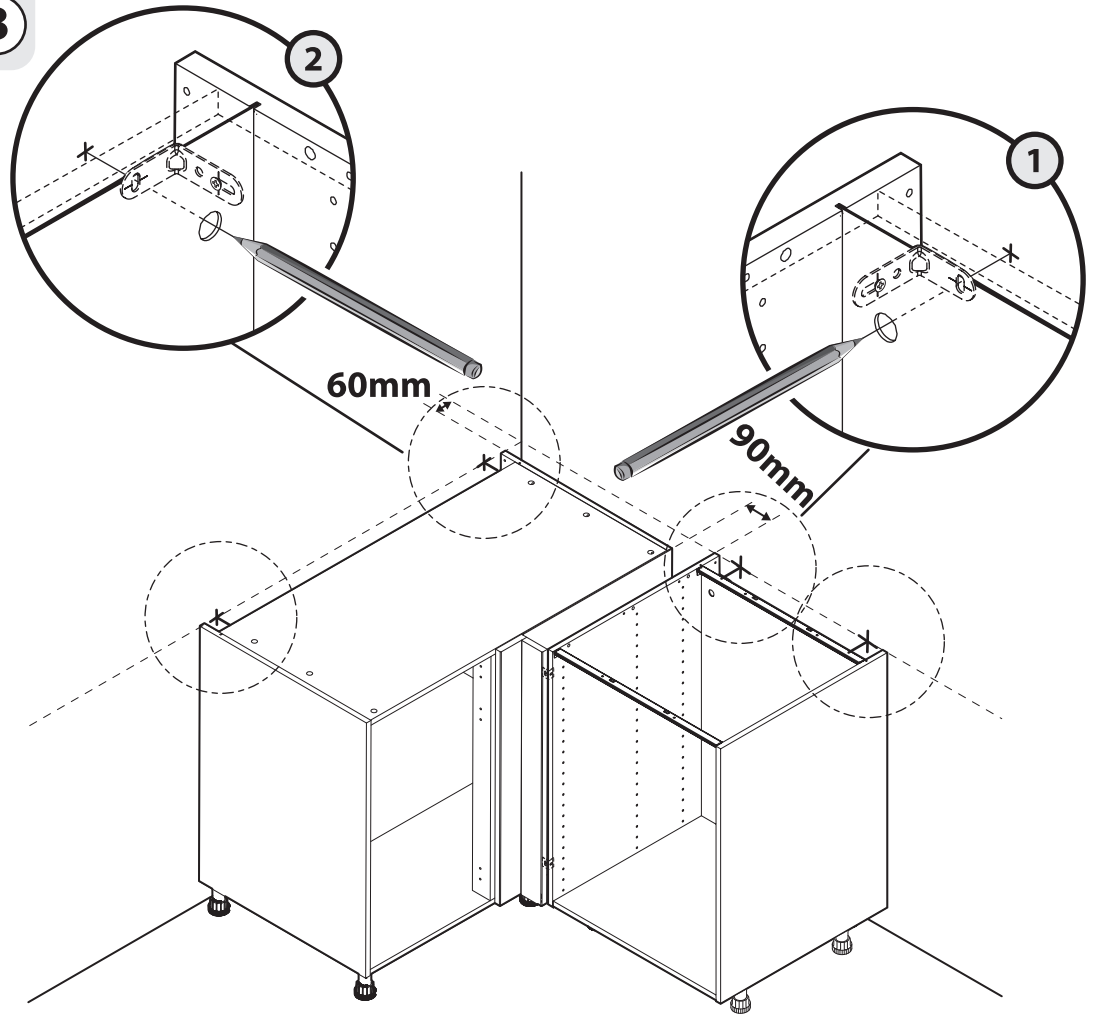
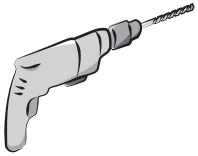

15 (B)

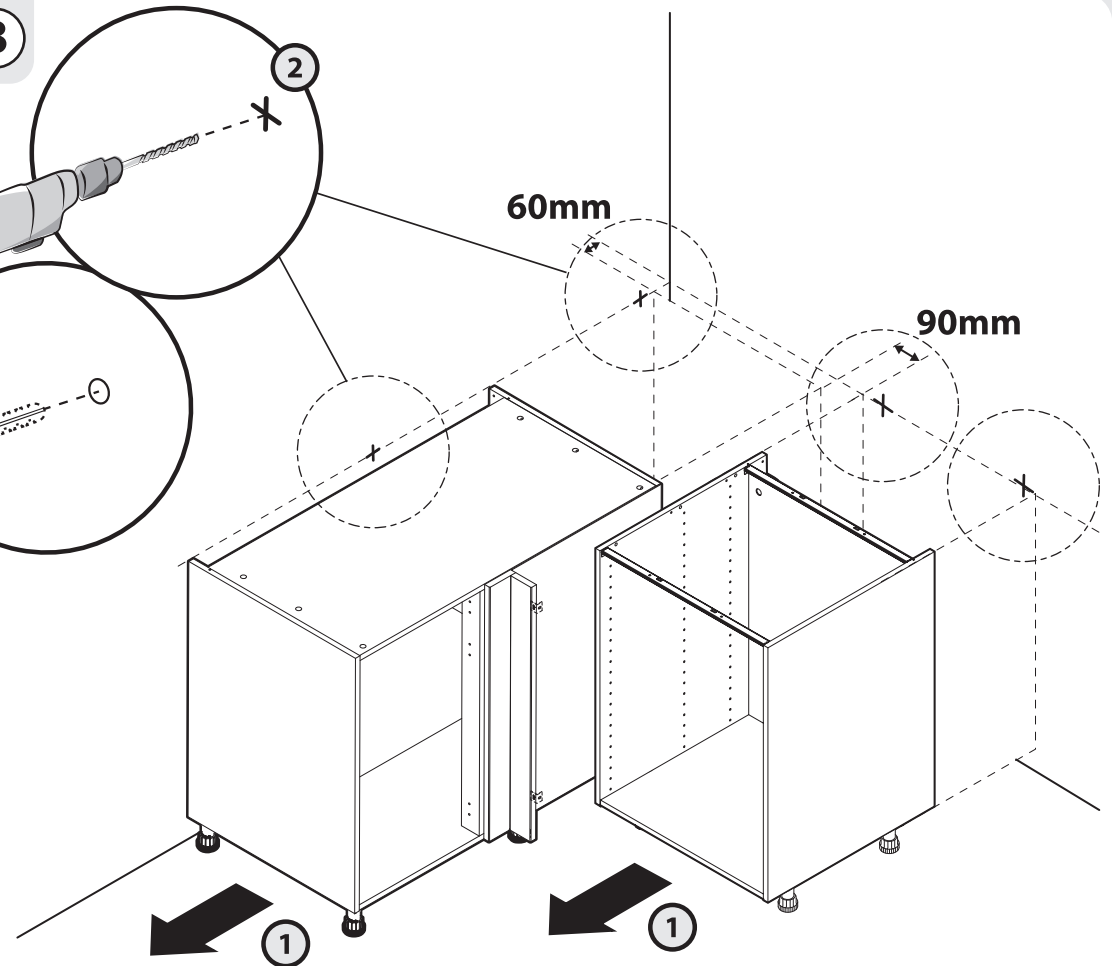
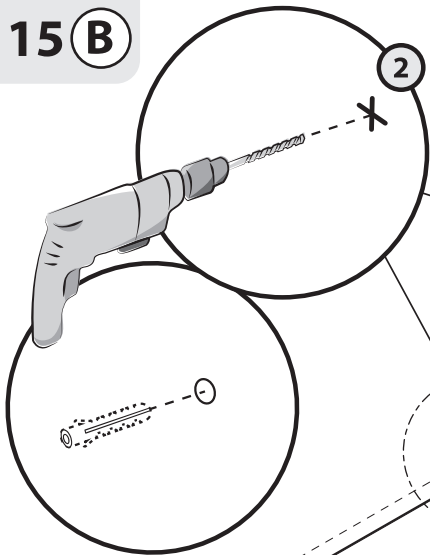

16 B



J
x3

4x30



O
x2



*
x9



Ø 2 mm

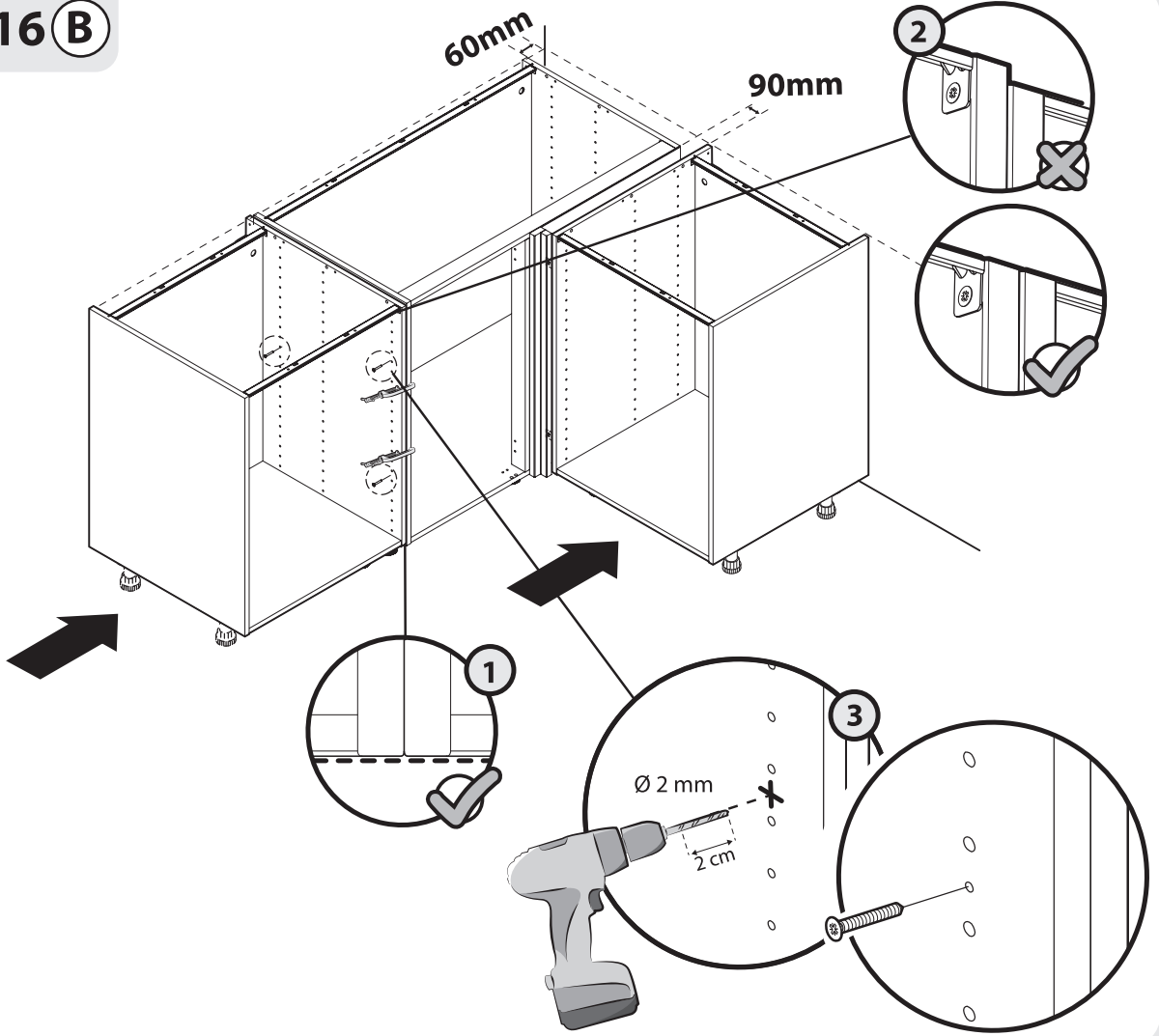
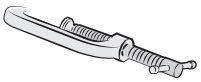

17 B

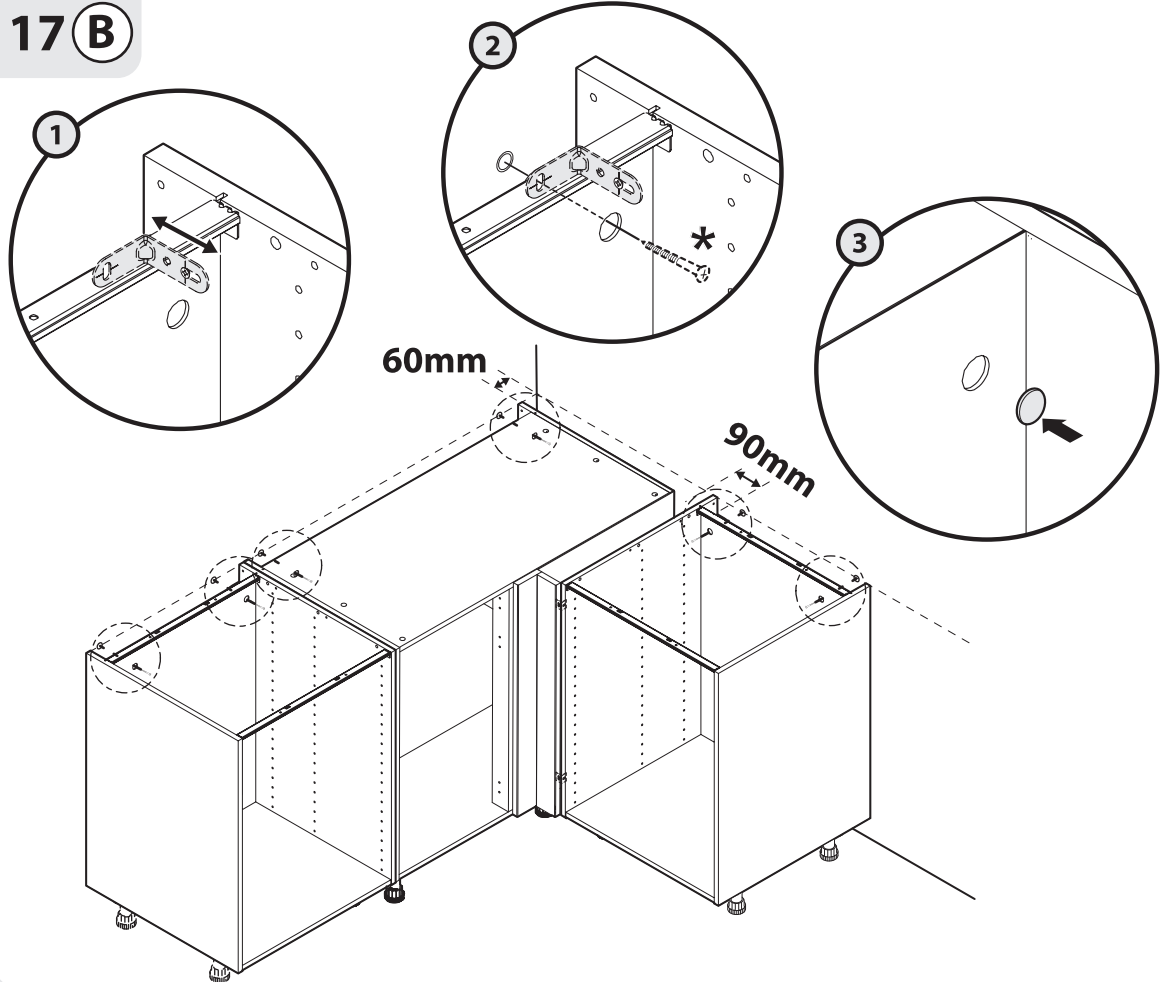

18 B

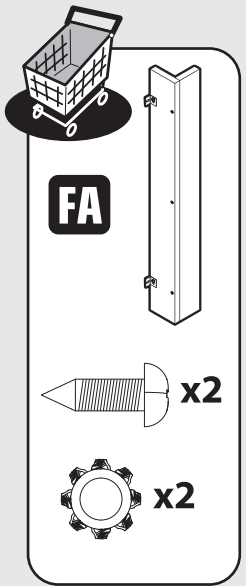
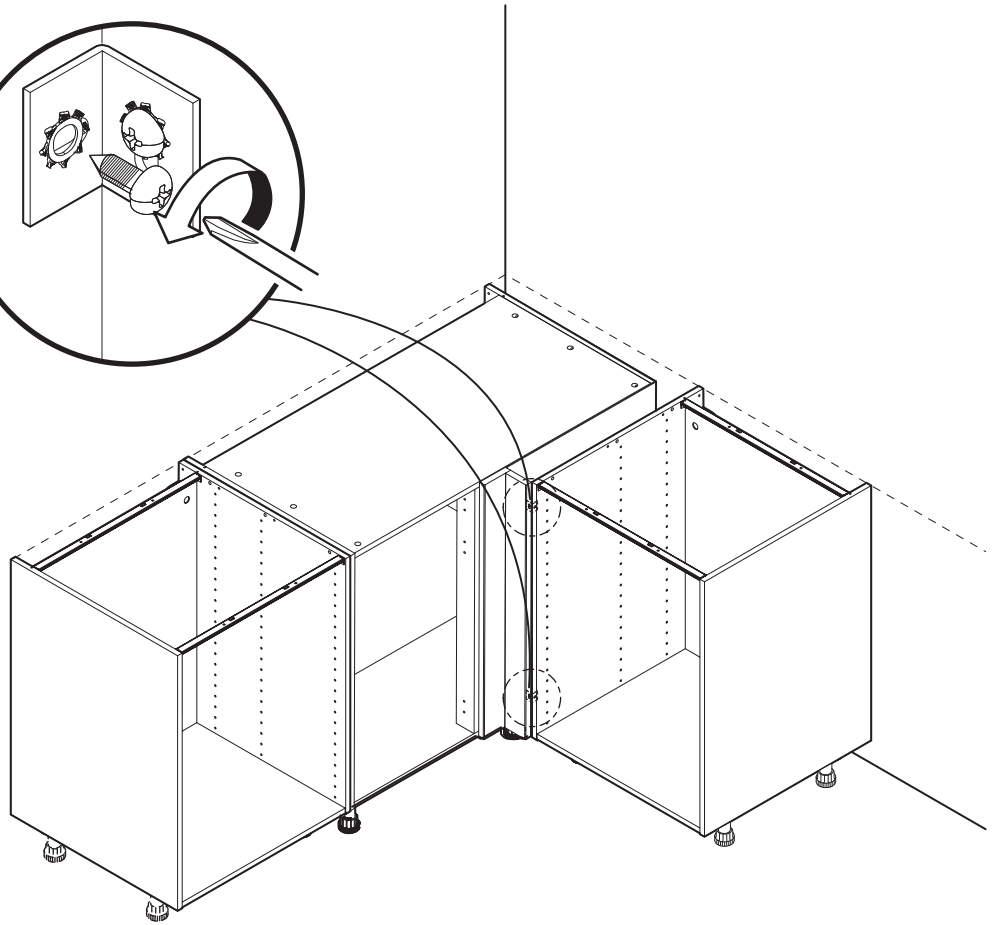
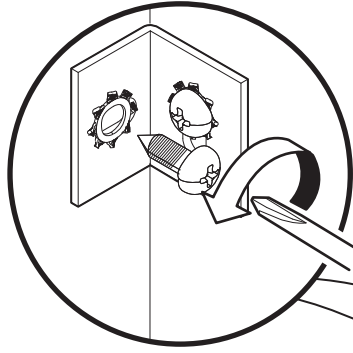
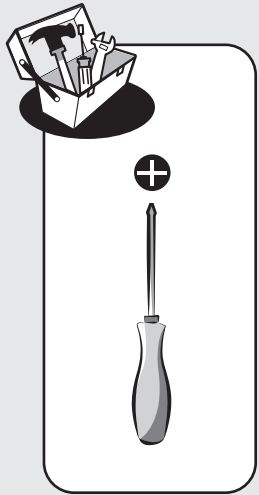

i

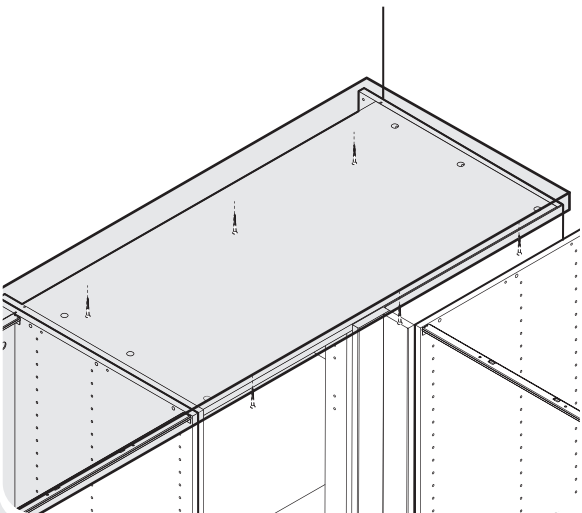
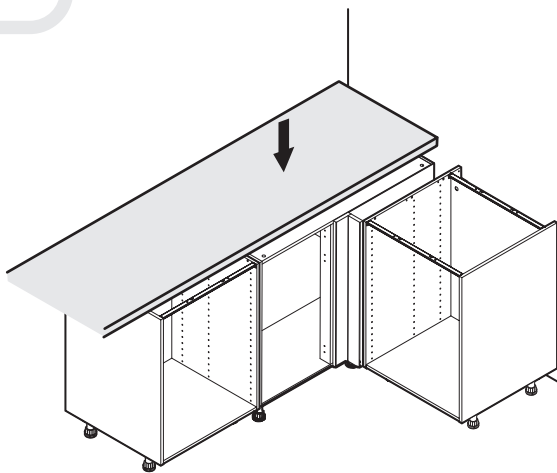

i

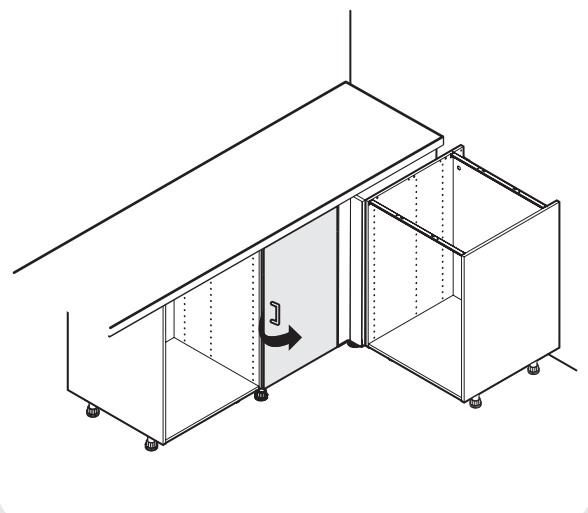
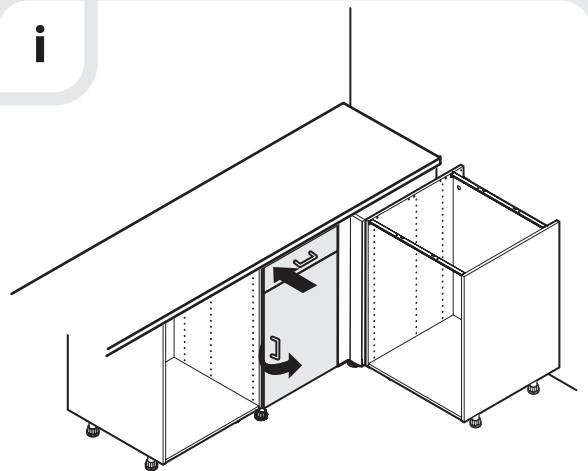

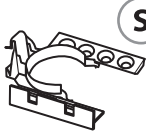

S

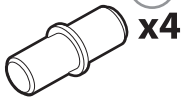

P x4



T x1

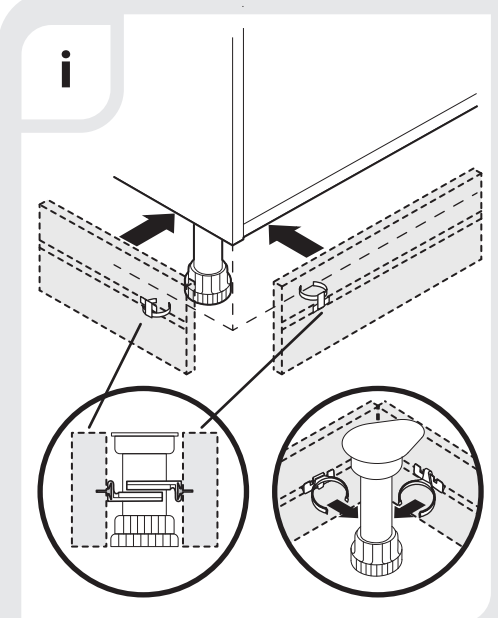
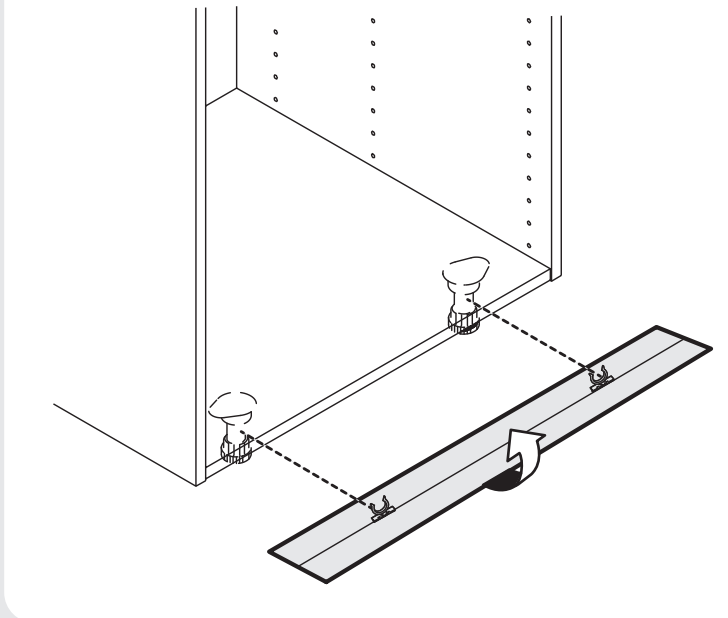
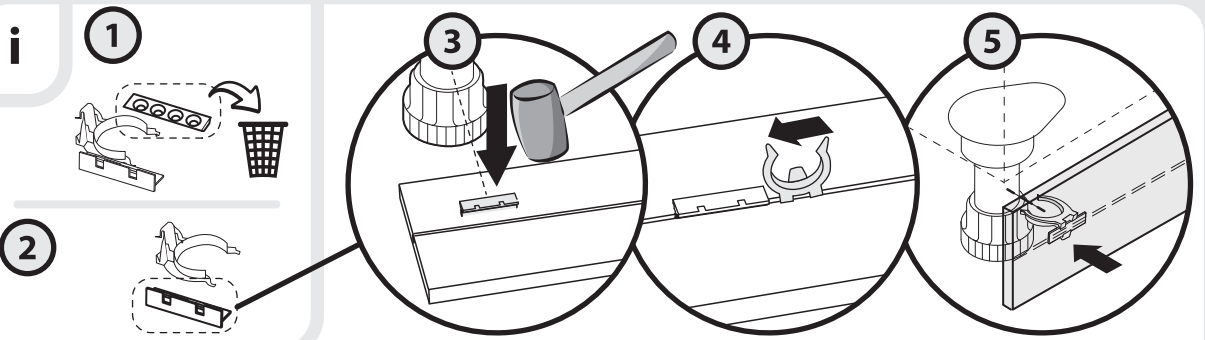
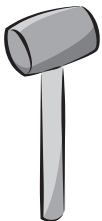

19 (B)

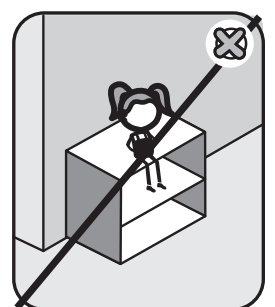
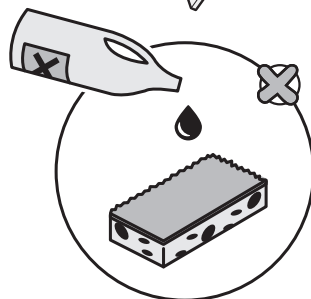
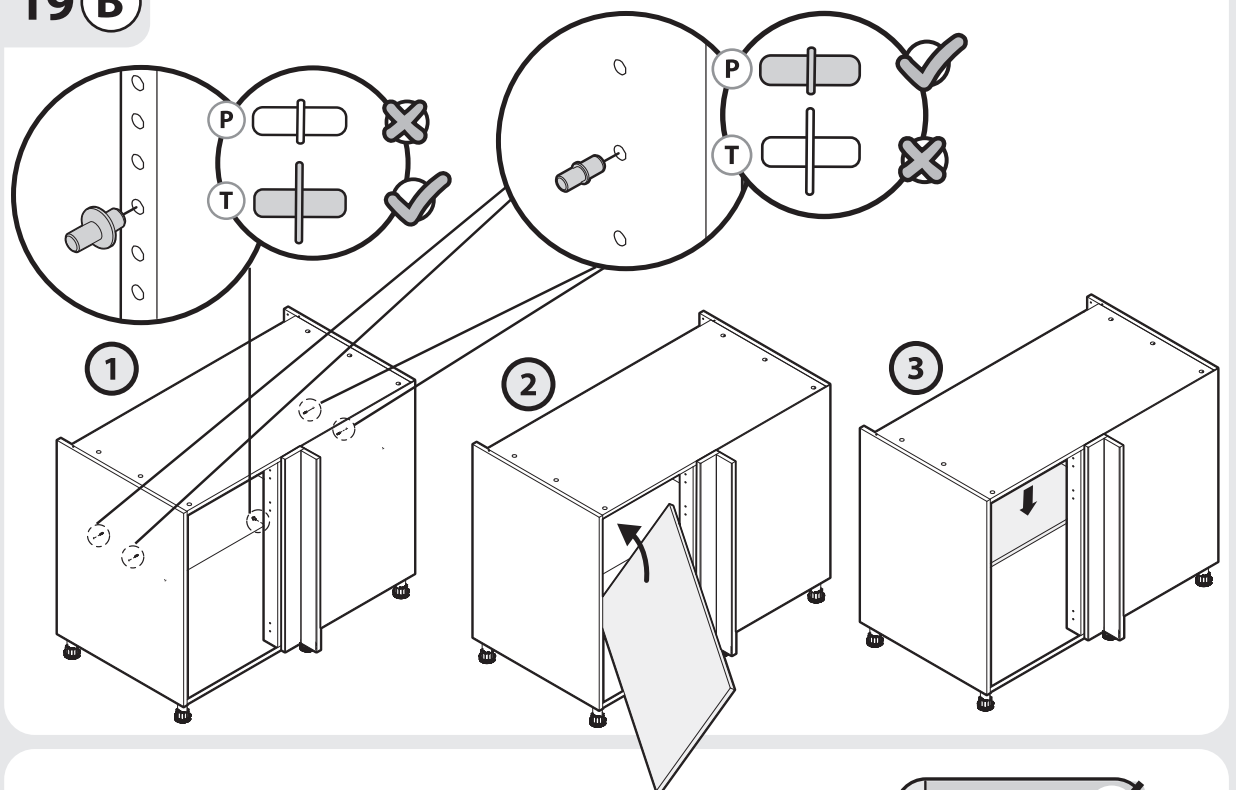



**FR / IMPORTANT, À CONSERVER POUR CONSULTATION ULTÉ-
RIEURE : À LIRE ATTENTIVEMENT _ES / IMPORTANTE, CONSERVAR PARA
CONSULTAR POSTERIORMENTE: LEER ATENTAMENTE _PT / IMPORTANTE
CONSERVAR PARA FUTURAS CONSULTAS: POR FAVOR, LEIA COM ATEN-
ÇÃO _IT / IMPORTANTE, DA CONSERVARE PER ULTERIORE CONSULTA-
ZIONE: DA LEGGERE ATTENTAMENTE _EL / ΣΗΜΑΝΤΙΚΟ! ΚΡΑΤΗΣΤΕ ΤΟ
ΓΙΑ ΜΕΛΛΟΝΤΙΚΗ ΑΝΑΦΟΡΑ. ΔΙΑΒΑΣΤΕ ΤΟ ΠΡΟΣΕΚΤΙΚΑ _PL / WAŻNE,
PRZECZYTAĆ UWAGAŻNIE I ZACHOWAĆ NA PRZYSZŁOŚĆ _RO / IMPORTANT,
A SE PASTRA PENTRU CONSULTAREA ULTERIOARA: CITIȚI CU
ATENȚIE _EN / IMPORTANT, TO BE RETAINED FOR FUTURE REFERENCE:
PLEASE READ CAREFULLY**

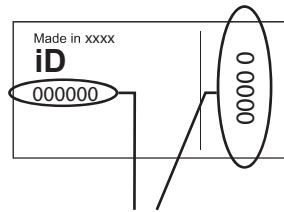

- FR** Etiquette de traçabilité présente sur le produit.
Référence à communiquer en cas de demande.
- ES** El producto cuenta con una etiqueta de trazabilidad.
En caso de reclamación, indicar esta referencia.
- PT** Etiqueta de reatrababilidade presente no produto.
Referência a comunicar se solicitado.
- IT** Etichetta di tracciabilità presente sul prodotto.
Codice da comunicare in caso di domanda.

- EL** Ετικέτα ιχνηλασιμότητας πάνω στο προϊόν.
Ο κωδικός αναφοράς πρέπει να αναφέρεται
σε περίπτωση αιτήματος.
- PL** Etykieta identyfikacyjna znajduje się na produkcie.
Dane referencyjne należy podać w przypadku pytań.
- RO** Etichetă de trasabilitate prezentă pe produs.
Dacă se solicită, comunică această referință.
- EN** Traceability label affixed to the product.
Reference to quote if requested.



**Ce meuble se recycle,
s'il n'est plus utilisable
déposez-le en déchèterie.
Notice à trier.
Pour en savoir plus :
www.quefairedemesdechets.fr**

- ES** Si ya no puede utilizarse, este mueble se puede reciclar,
deposite-lo en la unidad de clasificación de residuos.
- PT** Este móvel é reciclável. Quando deixar de ser utilizado,
deposite-o num centro de reciclagem de resíduos.
- IT** Questo mobile può essere riciclato,
portatelo in un'isola ecologica se inutilizzabile.
- EL** Το έπιπλο αυτό είναι ανακυκλώσιμο, εάν δεν
μπορεί πλέον να χρησιμοποιηθεί τοποθετήστε
το σε χώρο αποβλήτων.
- PL** Mebel ten poddawany jest recyklingowi, kiedy przestaje
być użyteczny należy go dostarczyć do punktu
zbiórki odpadów.
- RO** Această piesă de mobilier este reciclabilă. Dacă nu mai poate
fi folosită, vă rugăm să o duceți
la centrul de reciclare a deșeurilor.
- EN** This piece of furniture is recyclable. If it cannot
be used anymore, please take it to the waste
recycling centre.



ADEO Services - 135 Rue Sadi Carnot - CS00001
59790 RONCHIN - FRANCE

ZA

Imported by Adeo South Africa (PTY) LTD T/A Leroy Merlin,
Hosted in Leroy Merlin Fourways Store 35 Roos Street, Witkoppen Ext 97, Sandton
2191 Johannesburg, Gauteng, South Africa
Tel: +27 10 493 8000 Email: contact@leroymerlin.co.za

