

PARAMETRI TECNICI:

cod.	b	l	h	lt	kg	aggiungere TNT nero
	805	440	800	59	77	950x1300 mm

a corredo nel kit:
55 pz vite TSP Ø4x35

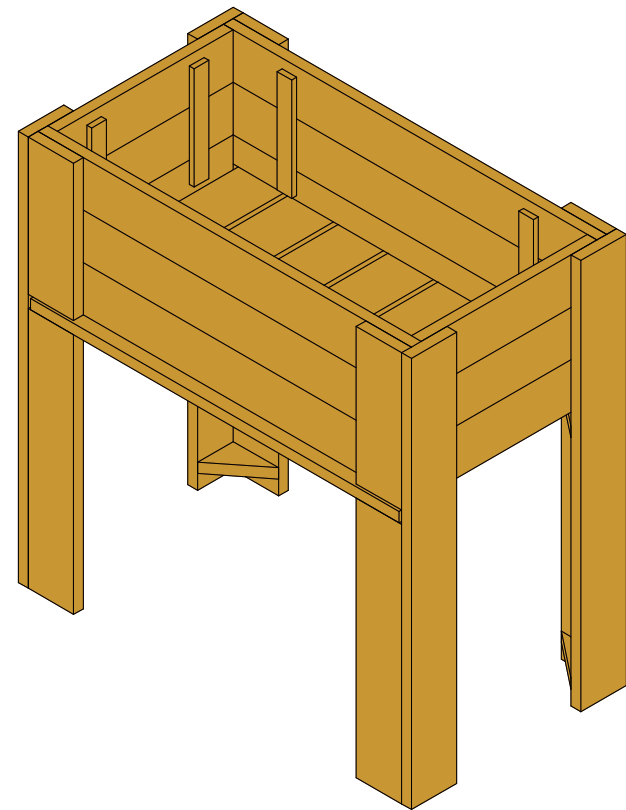
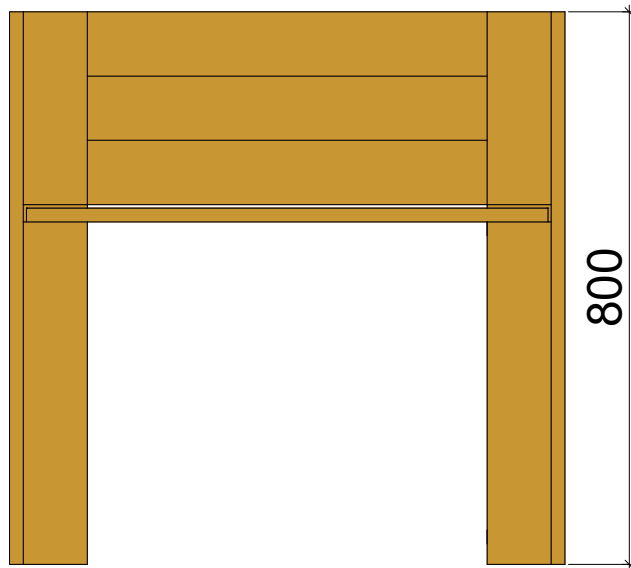
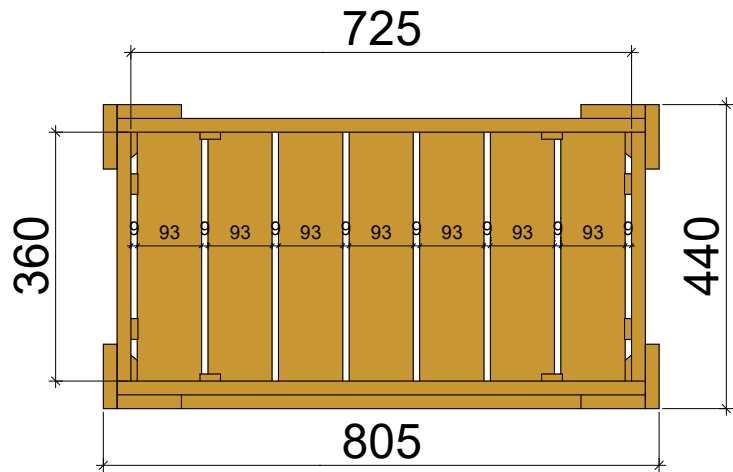

ATTENZIONE: FISSAGGIO CON VITI

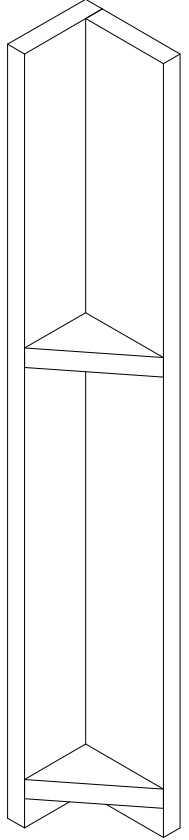
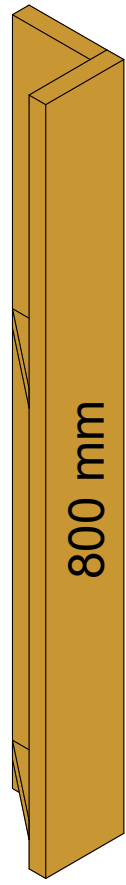
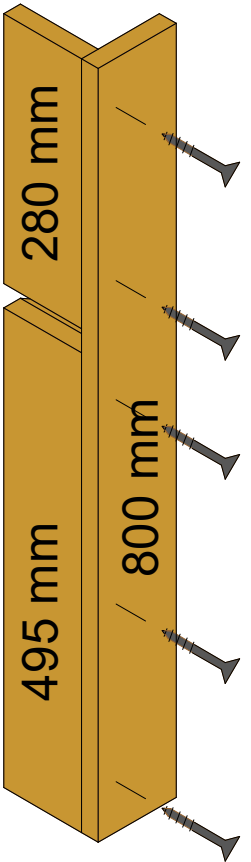
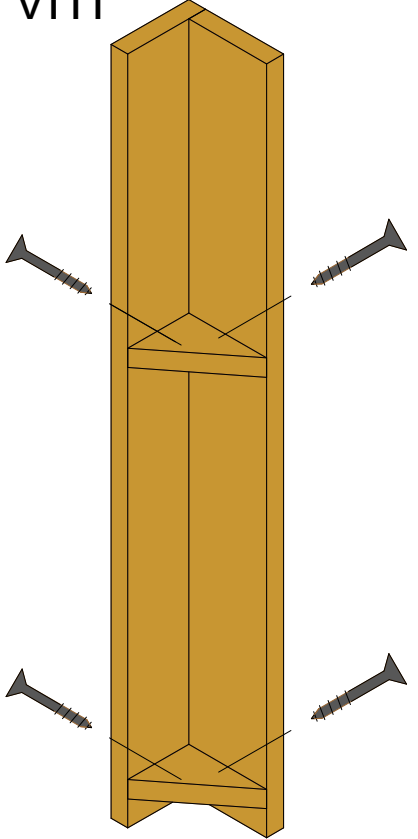
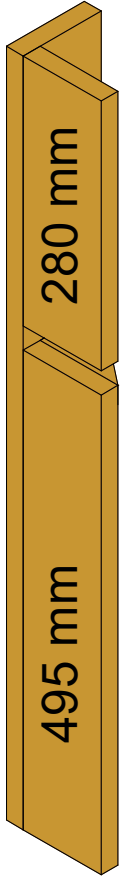
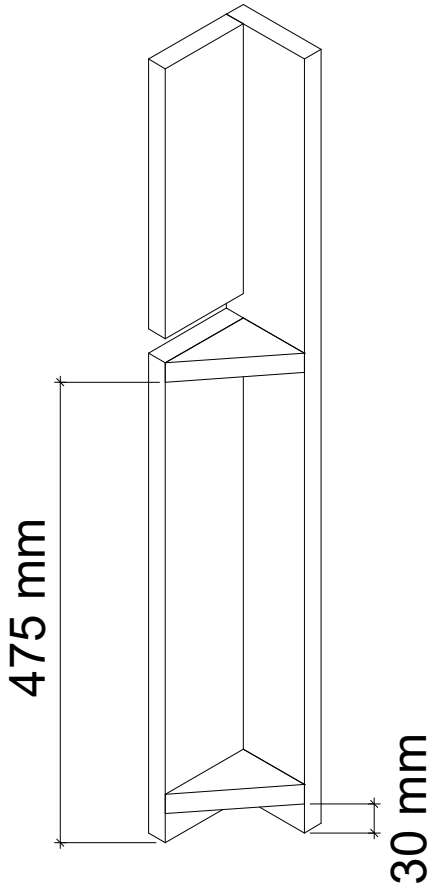

61225/11

TRATTAMENTO PINO+

MATERIALE NEL KIT

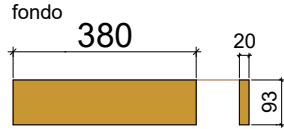

7 pz 20x93x380 mm

rinforzi

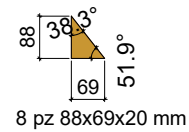

8 pz 88x69x20 mm

maniglia

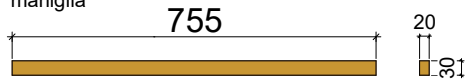

1 pz 20x30x755 mm

ASSEMBLAGGIO CON GRAFFE

2 pz fianco

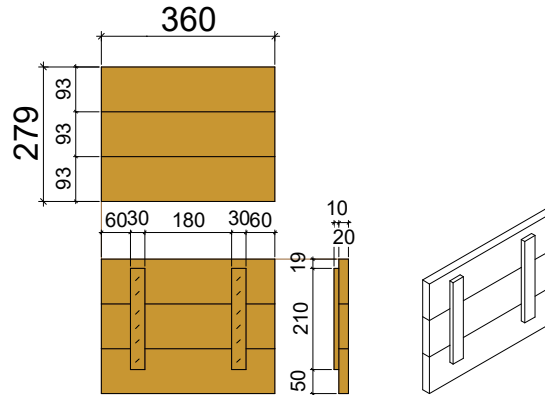

3 pz 20x93x360 mm
2 pz 10x30x210 mm

ASSEMBLAGGIO CON GRAFFE

2 pz fronte

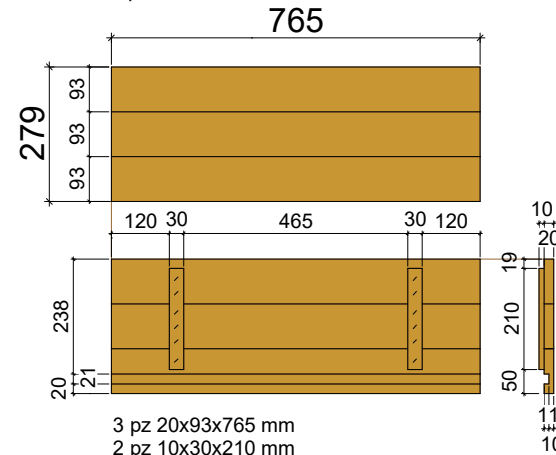

3 pz 20x93x765 mm
2 pz 10x30x210 mm

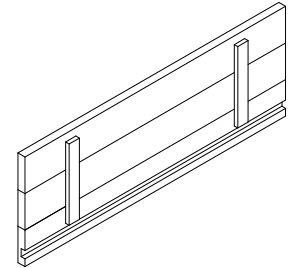

ASSEMBLAGGIO CON VITE

ATTENZIONE: raggiare tutte le teste

