

EAN CODE: 3276000596295  
3276000632436  
3276000596738

**FR** Manuel d'Instructions

**ES** Manual de Instrucciones

**PT** Manual de Instruções

**IT** Manuale di Istruzioni

**EL** Εγχειρίδιο Οδηγιών

**PL** Instrukcja Obsługi

**RU** Руководство по  
эксплуатации

**KZ** Пайдаланушы Нұсқаулығы

**UA** Інструкція з Експлуатації

**RO** Manual de Instrucțiuni

**BR** Manual de Instruções

**EN** Instructions Manual

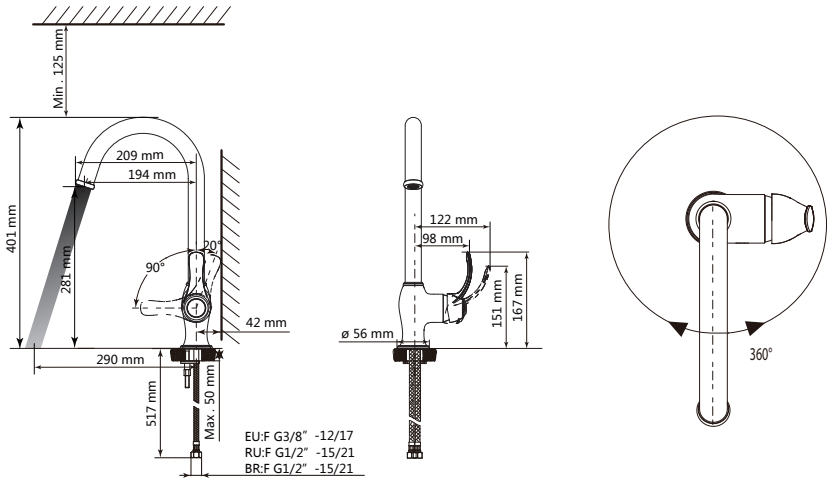

B

A

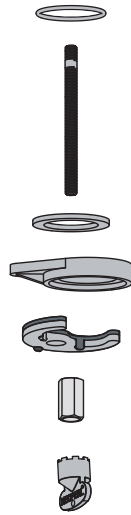
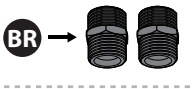
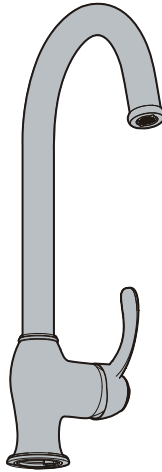

C

D

E

F

G

H

J

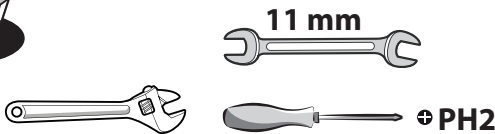



**FR:** Préparation / **ES:** Preparación / **PT:** Preparação / **IT:** Preparazione / **EL:** Προετοιμασία /  
**PL:** Przygotowanie / **RU:** Подготовка / **KZ:** Дайындау / **UA:** Підготування / **RO:** Pregătire / **BR:** Preparação /  
**EN:** Preparation



4



**FR:** Montage / **ES:** Montaje / **PT:** Montagem / **IT:** Montaggio / **EL:** Συναρμολόγηση /  
**PL:** Montaż / **RU:** Сборка / **KZ:** Монтаждау / **UA:** Збірка / **RO:** Montaj / **BR:** Montagem /  
**EN:** Assembly



5 → 7



**FR:** Utilisation eau chaude-eau froide/ **ES:** Utilización agua caliente-agua fría/ **PT:** Utilização água quente-água fria/  
**IT:** Uso acqua calda-acqua fredda/ **EL:** Χρήση ζεστού-κρύου νερού/ **PL:** Użytkowanie zimnej wody-gorącej wody/  
**RU:** использование горячей и холодной воды/ **KZ:** Суық және ыстық суды қолдану/  
**UA:** використання гарячої - холодної води/ **RO:** Utilizare apă caldă-apă rece/ **BR:** Uso de água quente e fria/  
**EN:** Using hot and cold water



8

**FR:** Changement de cartouche/ **ES:** Cambio de cartucho/ **IT:** Cambio cartuccia/ **PT:** Mudança de cartucho/  
**EL:** Αλλαγή φιασίγιου/ **PL:** Wymiana wkładu / **RU:** Смена картриджа/ **KZ:** Картриджді ауыстыру/  
**UA:** Заміна картриджа/ **RO:** Schimbare cartuş/ **BR:** Substituição de cartucho/ **EN:** Replacing the cartridge



9 → 12

**FR:** Changement de mousseur/ **ES:** Cambio de aireador/ **PT:** Mudança de arejador/ **IT:** Cambio rompigetto/  
**EL:** Αλλαγή αεράτορα / **PL:** Wymiana perlatora / **RU:** Смена аэратора/ **KZ:** Ауақанықтырғышты ауыстыру/  
**UA:** Заміна аератора/ **RO:** Schimbare aerator/ **BR:** Substituição do aerador/ **EN:** Replacing the aerator



13

**FR:** Changement de flexibles/ **ES:** Cambio de flexibles / **PT:** Mudança de flexíveis/ **IT:** Cambio flessibili/  
**EL:** Αλλαγή λάστιχων/ **PL:** Wymiana wężyków instalacyjnych / **RU:** Смена гибкого шланга для смесителя/  
**UA:** Заміна гнучкого шланга для змішувача/ **KZ:** Қоспалауышқа арналған иілгіш шлангты ауыстыру/  
**RO:** Schimbare furtune flexibile/ **BR:** Substituição das mangueiras/ **EN:** Replacing the hoses



14 → 15



FR: Préparation / ES: Preparación / PT: Preparação / IT: Preparazione / EL: Προετοιμασία /  
PL: Przygotowanie / RU: Подготовка / KZ: Дайындау / UA: Підготування / RO: Pregătire /  
BR: Preparação / EN: Preparation

1

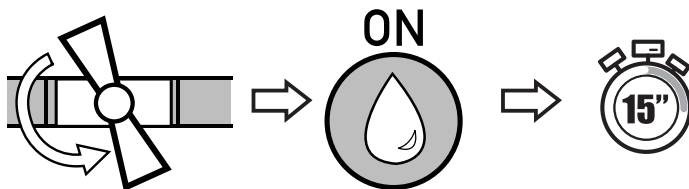

2

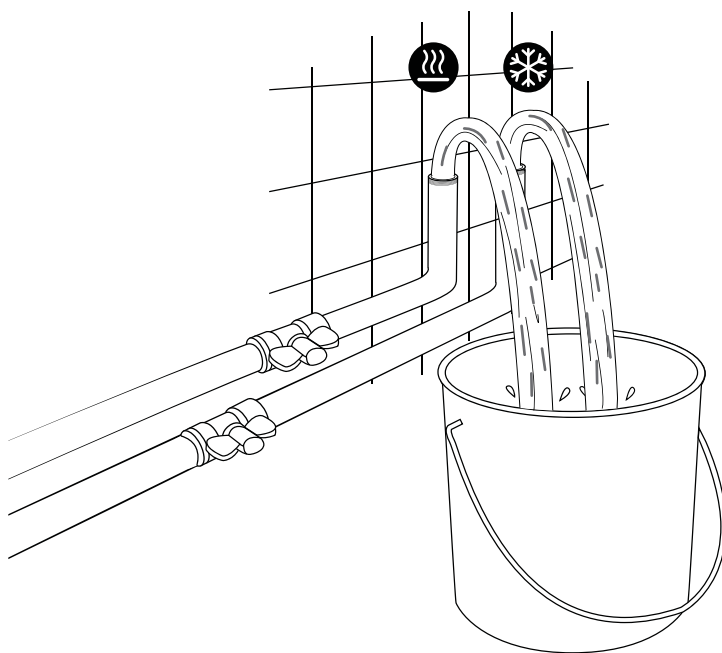

3

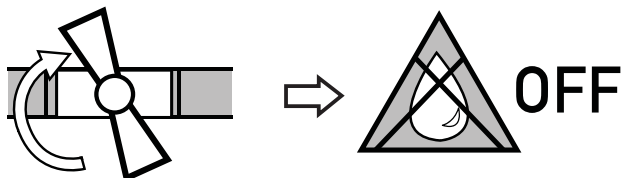



FR: Montage / ES: Montaje / PT: Montagem / IT: Montaggio / EL: Συναρμολόγηση /  
PL: Montaż / RU: Сборка / KZ: Монтажday / UA: Збірка / RO: Montaj / BR: Montagem /  
EN: Assembly

1

1

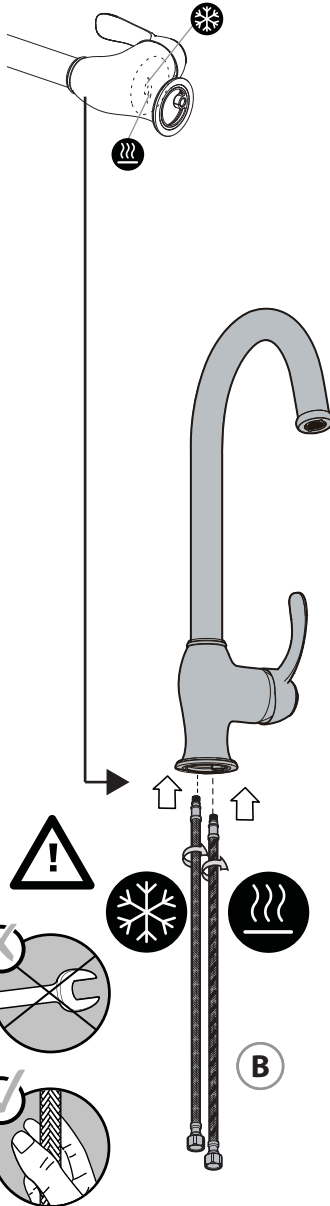

2

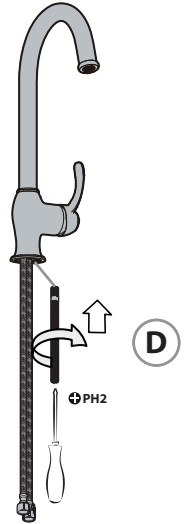

3

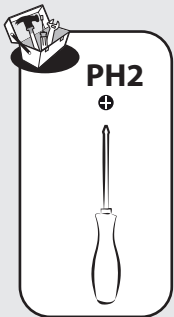
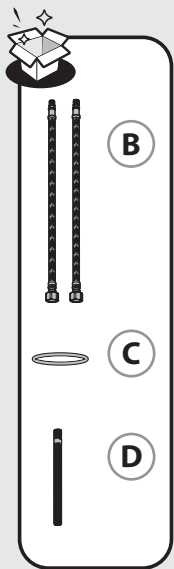
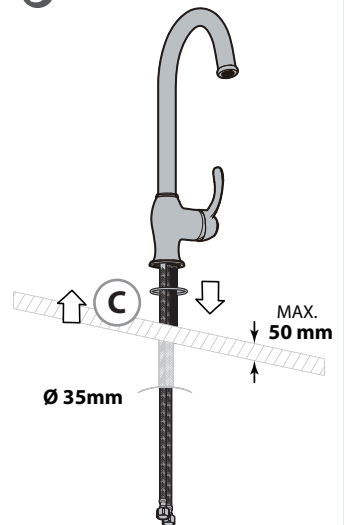

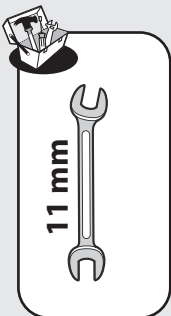
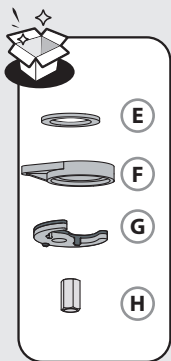

2

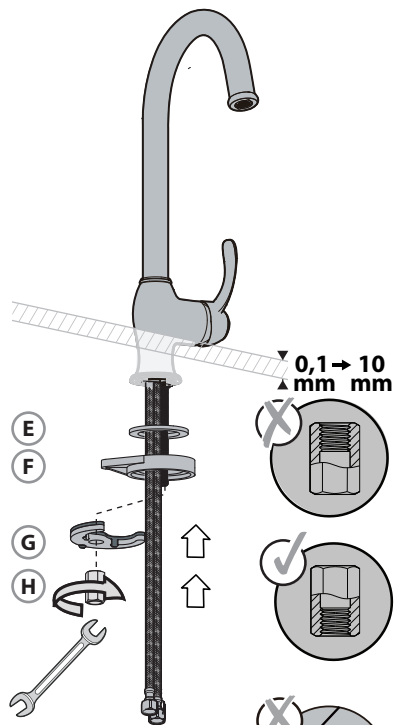
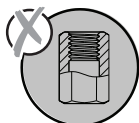
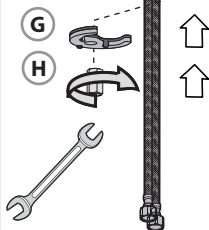
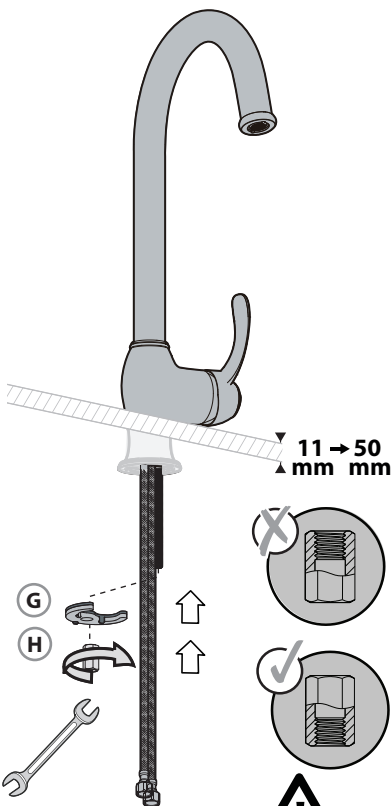
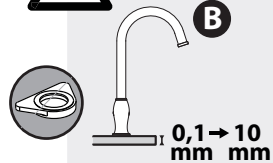
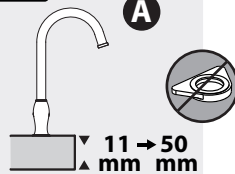

E  
F

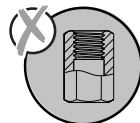

G  
H

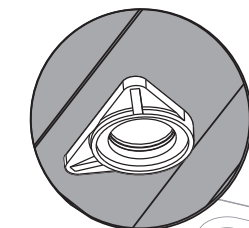

F

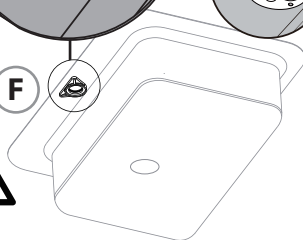

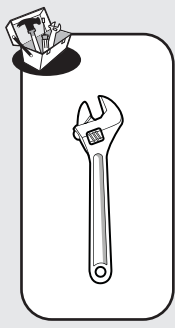

3

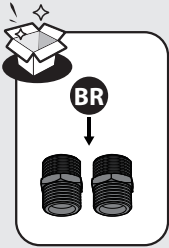
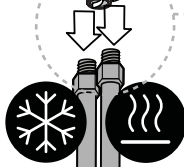
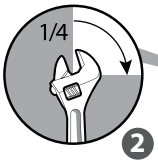
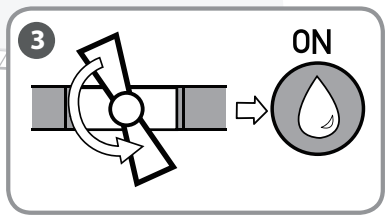
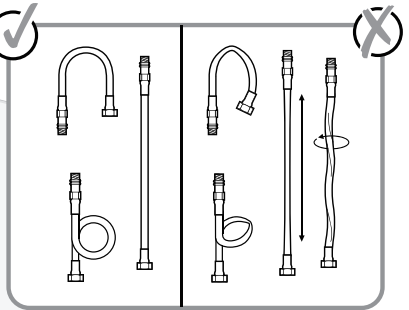
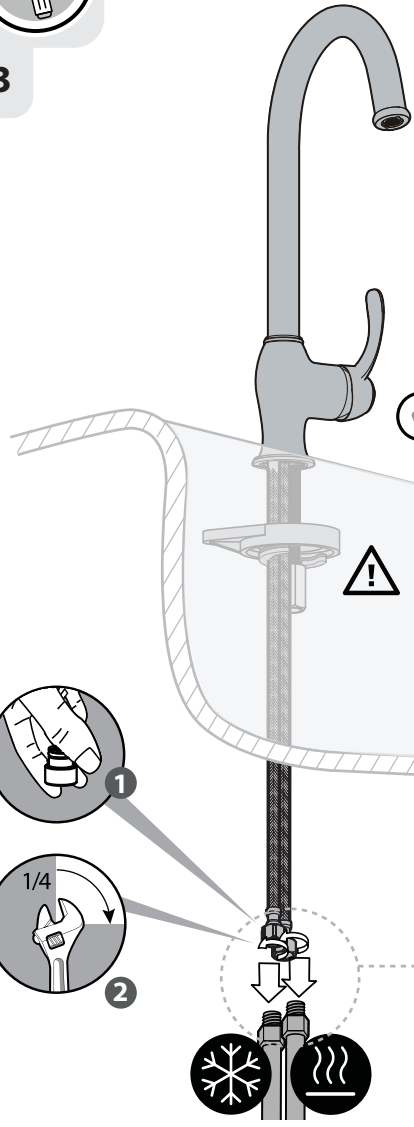

! + BR

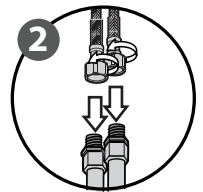
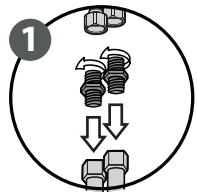
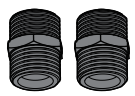



FR: Utilisation eau chaude-eau froide/ ES: Utilización agua caliente-agua fría/ PT: Utilização água quente-água fria/  
IT: Uso acqua calda-acqua fredda/ EL: Χρήση ζεστού-κρύου νερού/ PL: Użytkowanie zimnej wody-gorącej wody/  
RU: использование горячей и холодной воды/ KZ: Суық және ыстық суды қолдану/  
UA: використання гарячої - холодної води/ RO: Utilizare apă caldă-apă rece/ BR: Uso de água quente e fria/  
EN: Using hot and cold water

1

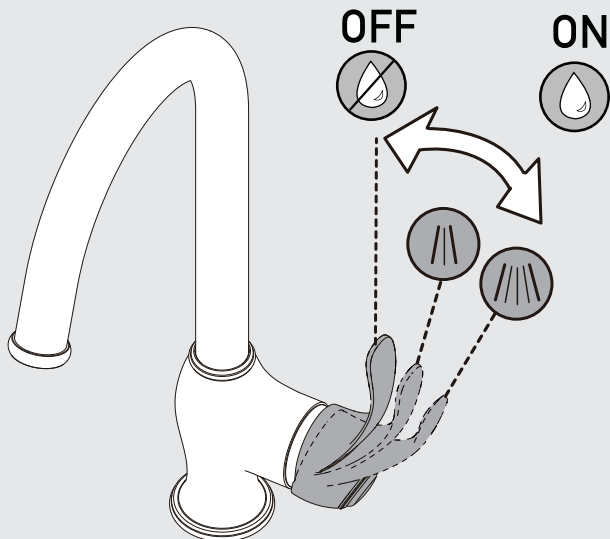
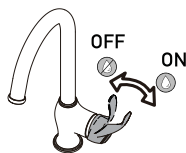

2

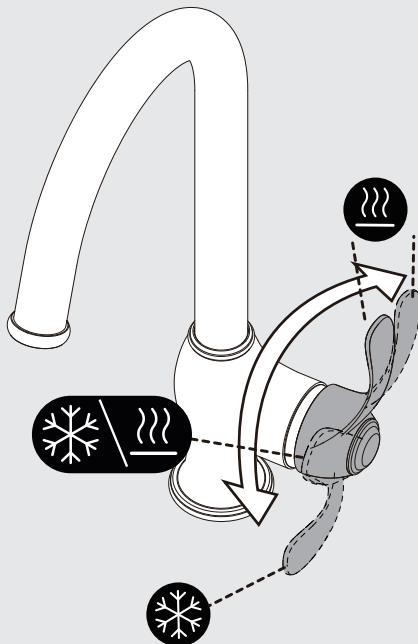

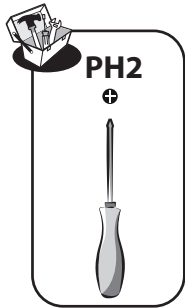

FR: Changement de cartouche/ ES: Cambio de cartucho/ IT: Cambio cartuccia/ PT: Mudança de cartucho/  
EL: Αλλαγή φυσιγγίου/ PL: Wymiana wkładu / RU: Смена картриджа/ KZ: Картриджді ауыстыру/  
UA: Заміна картриджа/ RO: Schimbare cartuş/ BR: Substituição de cartucho/ EN: Replacing the cartridge

1

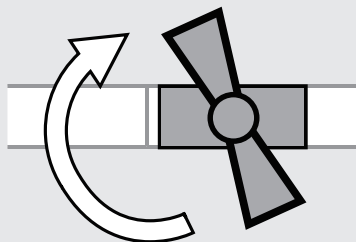

2

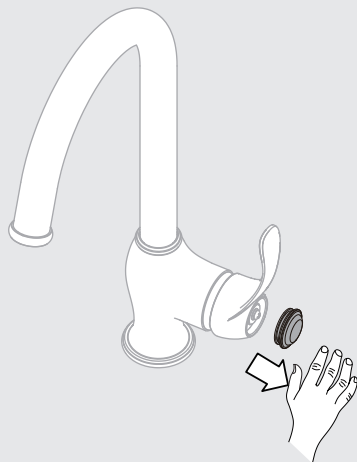

3

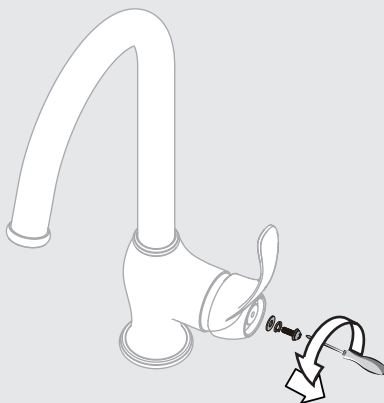

4

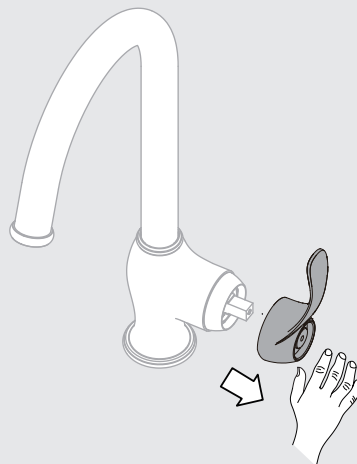

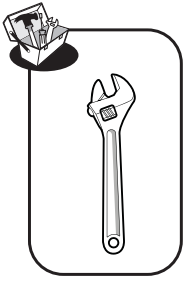

**FR:** Changement de cartouche/ **ES:** Cambio de cartucho/ **IT:** Cambio cartuccia/ **PT:** Mudança de cartucho/  
**EL:** Αλλαγή φουσιγγίου/ **PL:** Wymiana wkładu / **RU:** Смена картриджа/ **KZ:** Картриджді ауыстыру/  
**UA:** Заміна картриджа/ **RO:** Schimbare cartuş/ **BR:** Substituição de cartucho/ **EN:** Replacing the cartridge

5

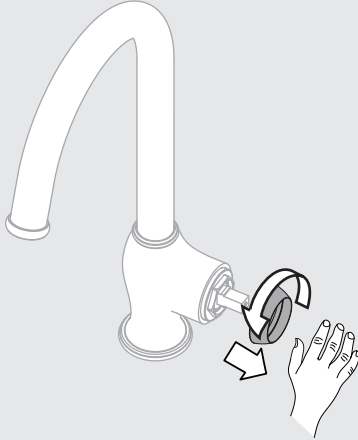

6

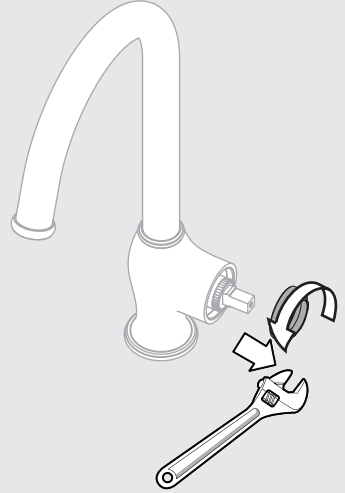

7



8

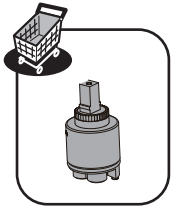
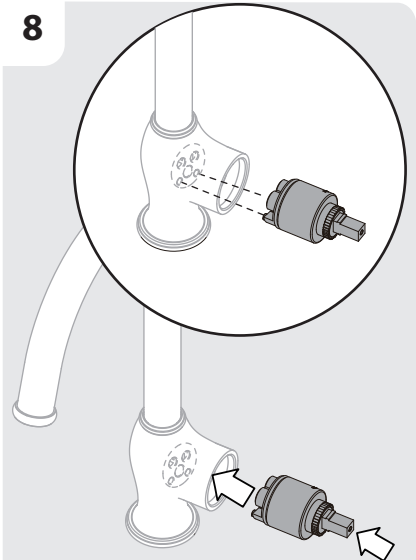

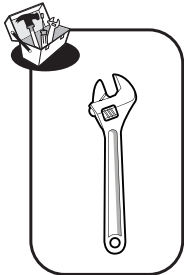

FR: Changement de cartouche/ ES: Cambio de cartucho/ IT: Cambio cartuccia/ PT: Mudança de cartucho/  
EL: Αλλαγή φουσιγγίου/ PL: Wymiana wkładu / RU: Смена картриджа/ KZ: Картриджді ауыстыру/  
UA: Заміна картриджа/ RO: Schimbare cartus/ BR: Substituição de cartucho/ EN: Replacing the cartridge

9

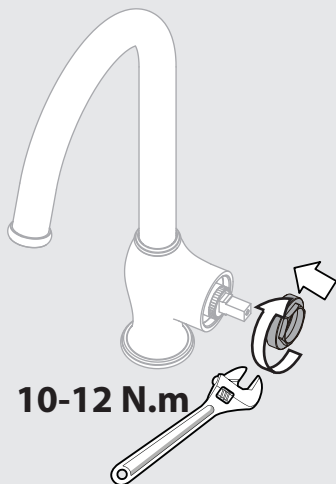

10

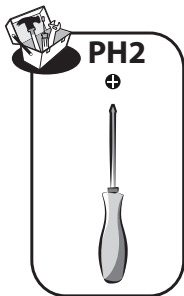
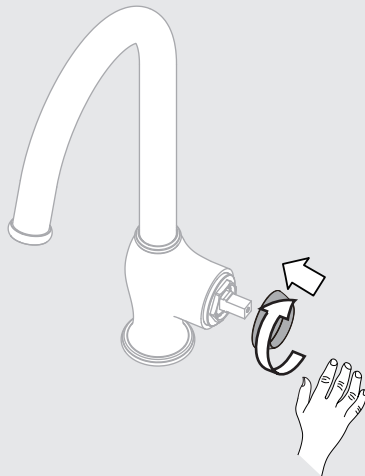

PH2



11

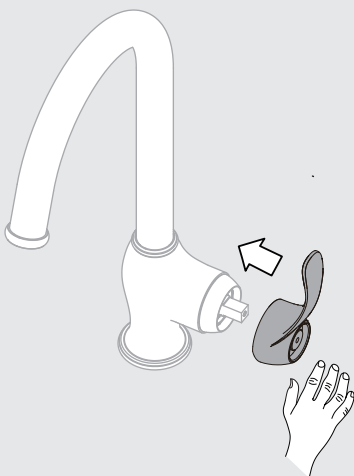

12

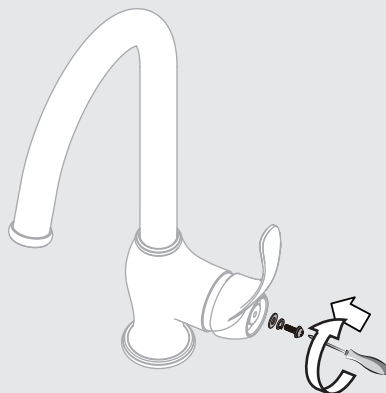



**FR:** Changement de cartouche/ **ES:** Cambio de cartucho/ **IT:** Cambio cartuccia/ **PT:** Mudança de cartucho/  
**EL:** Αλλαγή φιασιγγίου/ **PL:** Wymiana wkładu / **RU:** Смена картриджа/ **KZ:** Картриджді ауыстыру/  
**UA:** Заміна картриджа/ **RO:** Schimbare cartuş/ **BR:** Substituição de cartucho/ **EN:** Replacing the cartridge

13

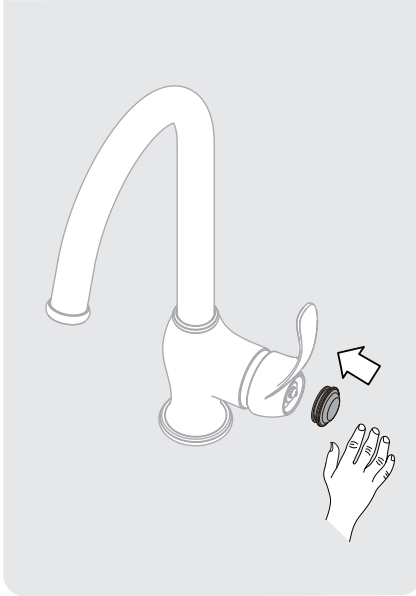

14

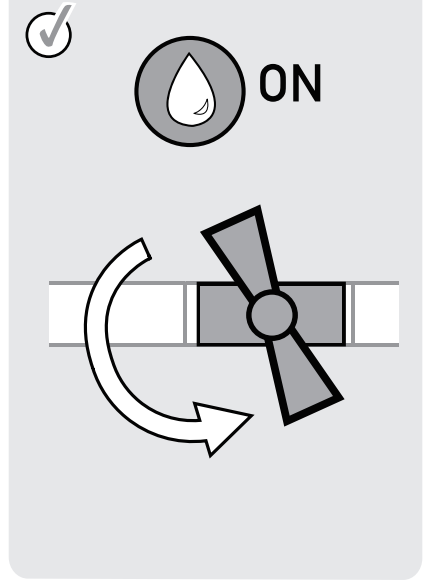

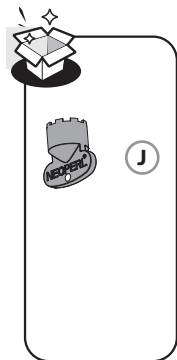

FR: Changement de mousseur/ ES: Cambio de aireador/ PT: Mudança de arejador/ IT: Cambio rompigetto/  
 EL: Αλλαγή αεράτορα / PL: Wymiana perlatora / RU: Смена аэратора / KZ: Ауақанықтырғышты ауыстыру/  
 UA: Заміна аератора/ RO: Schimbare aerator/ BR: Substituição do aerador/ EN: Replacing the aerator

1

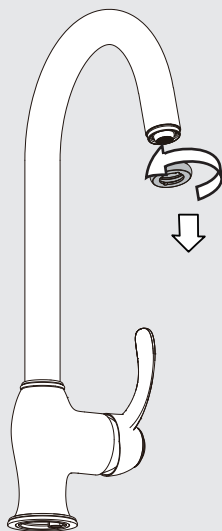

2

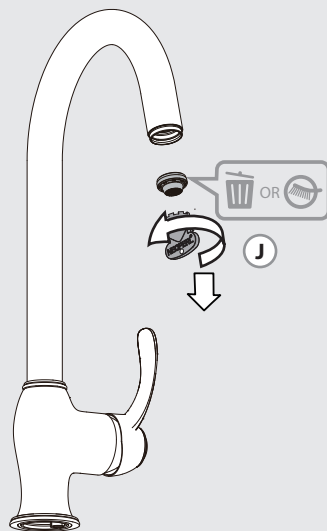

FR Nettoyage	EL Καθαρισμός	UA Очищення
ES Limpieza	PL Czyszczenie	RO Curățare
PT Limpeza	RU Чистка	BR Limpeza
IT Pulizia	KZ тазарту	EN Cleaning

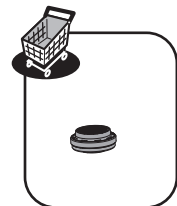

3

FR Vinaigre	IT Aceto	RU Уксус	RO Oțet
ES Vinagre	EL Ξίδι	KZ Сірке су	BR Vinagre
PT Vinagre	PL Ocet	UA Оцет	EN Vinegar

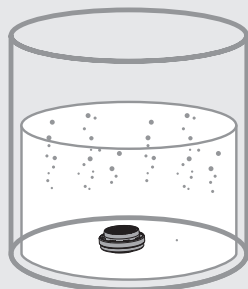

4

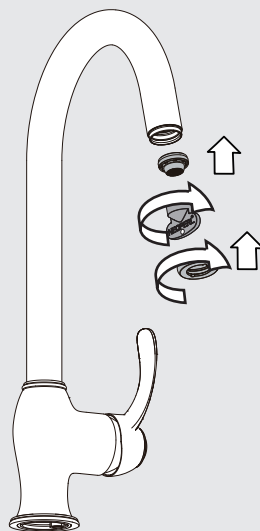

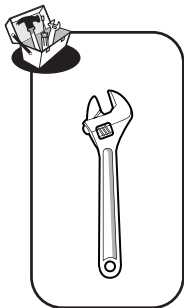

FR: Changement de flexibles/ ES: Cambio de flexibles / PT: Mudança de flexíveis/ IT: Cambio flessibili/  
EL: Αλλαγή λάστιχων/ PL: Wymiana wężyków instalacyjnych / RU: Смена гибкого шланга для смесителя/  
UA: Заміна гнучкого шланга для змішувача/ KZ: Қоспалауышқа арналған иілгіш шлангты ауыстыру/  
RO: Schimbare furtune flexibile/ BR: Substituição das mangueiras/ EN: Replacing the hoses

1

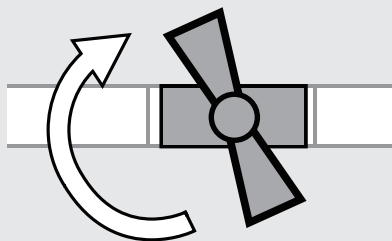

2

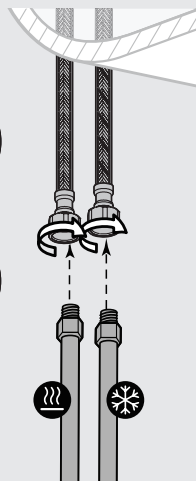

3



ON

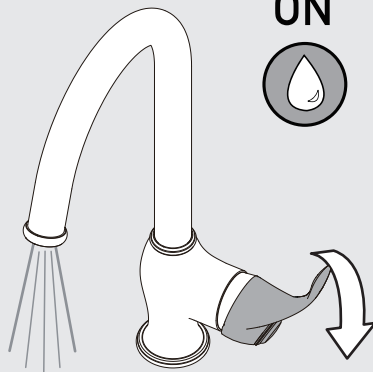

4

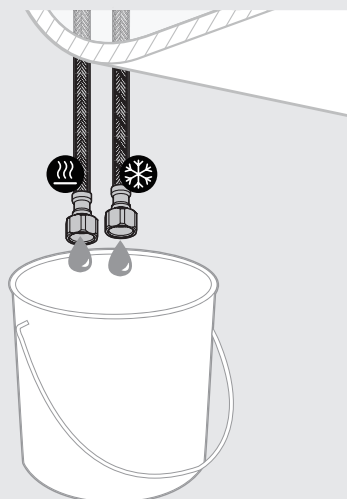

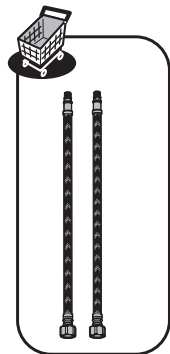

FR: Changement de flexibles/ ES: Cambio de flexibles / PT: Mudança de flexíveis/ IT: Cambio flessibili/  
 EL: Αλλαγή λάστιχων/ PL: Wymiana wężyków instalacyjnych / RU: Смена гибкого шланга для смесителя/  
 UA: Заміна гнучкого шланга для змішувача/ KZ: Қоспалауышқа арналған иілгіш шлангты ауыстыру/  
 RO: Schimbare furtune flexibile/ BR: Substituição das mangueiras/ EN: Replacing the hoses

5

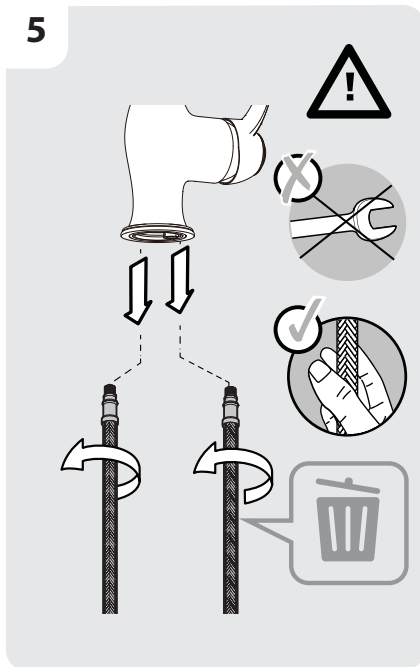

6

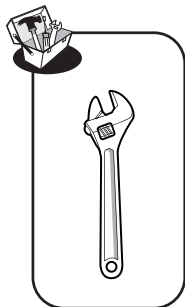
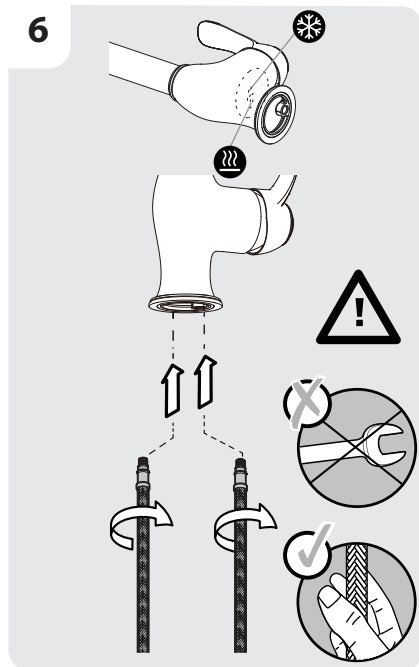

7

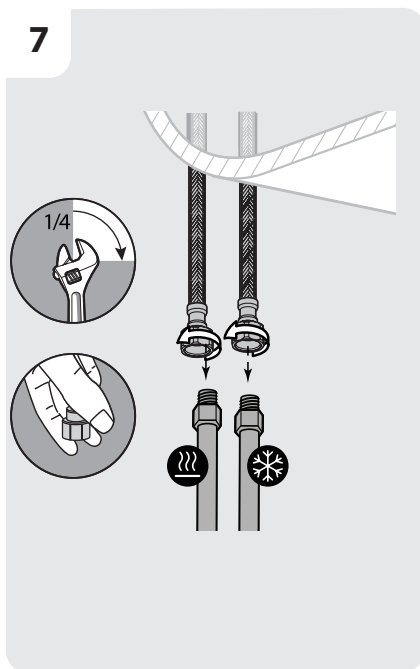

8

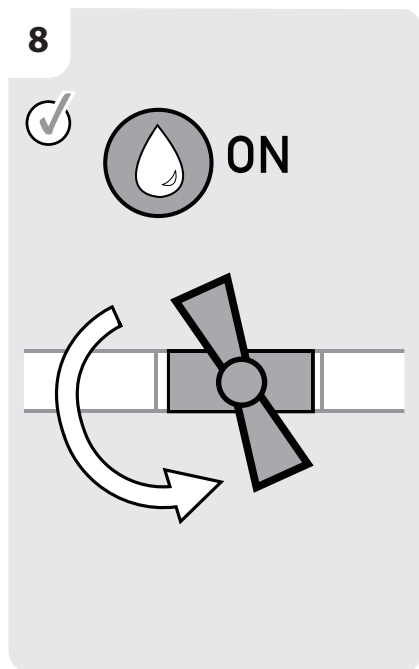



Eau claire / Agua limpia / Água limpa / Acqua pulita / Καθαρό νερό / Czysta woda / Чистая вода / Água limpa /  
Чиста вода / Ara curata / таза су / Clean water



Sans solvant / Sin disolvente / Sem solventes / Senza solventi / Χωρίς διαλυτικά / Bez rozpuszczalnika / Без растворителя /  
Sem solventes/ Без розчинника / Fara solvent / еріткішчиз/ Solvent-free

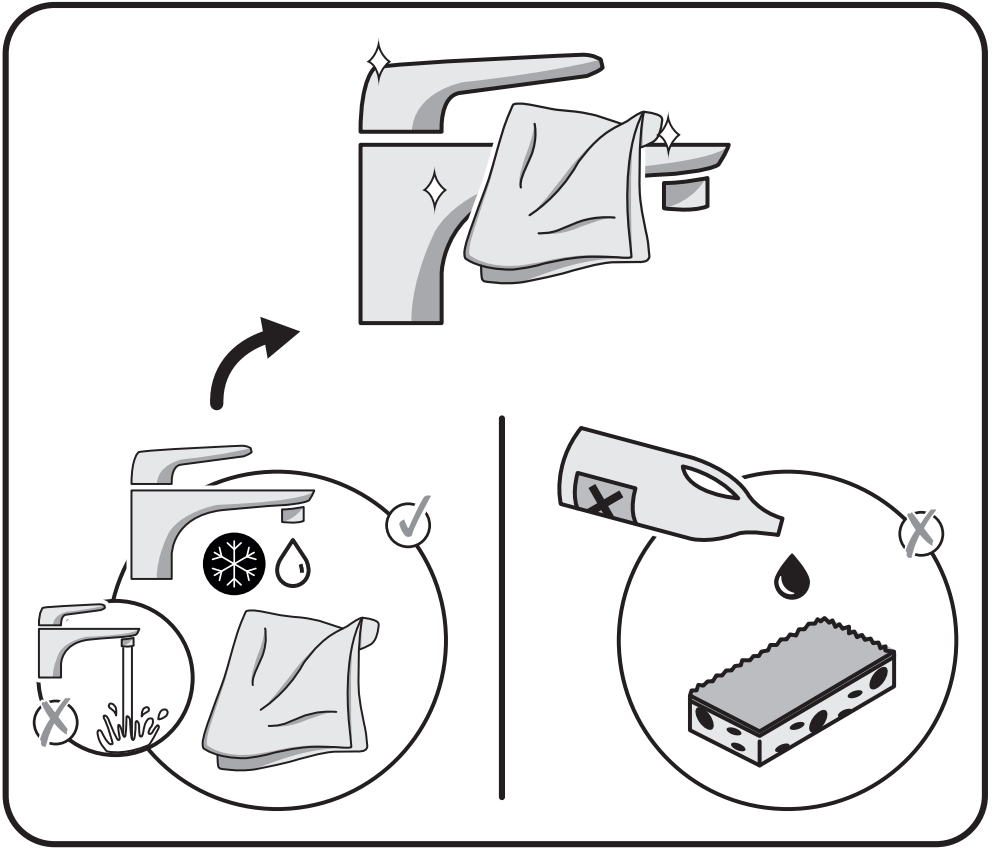



Part-listing				
No	Description	Code No	QTY	Remark
1	Handle Cover	B01-3116A01	1	
2	Handle	B01-3116A02	1	
3	Beautify Cover	B14-3116A03	1	
4	Pressing Nut	B15-3116A04	1	
5	Cartridge	EC40 CD COLD DUE MIRROR	1	
6	Fixing Part	C96-3116A05	1	
7	Flexible Hose	TAQ-PEX-DN6-ACB H3/8-M8x1 L12 550 MM(3276000596295)	2	
		TAQ-PEX-DN6-ACB H1/2-M8x1 L12 550 MM(3276000632436,3276000596738)		
8	Aerator	40.8430.010	1	
9	Aerator housing	B17-3116A06	1	
10	Aerator Key	09.9152.0	1	
11	Body	B00-3117A07	1	
12	Spout	B10-3116A08	1	
13	Connector	B13-3116A09	2	

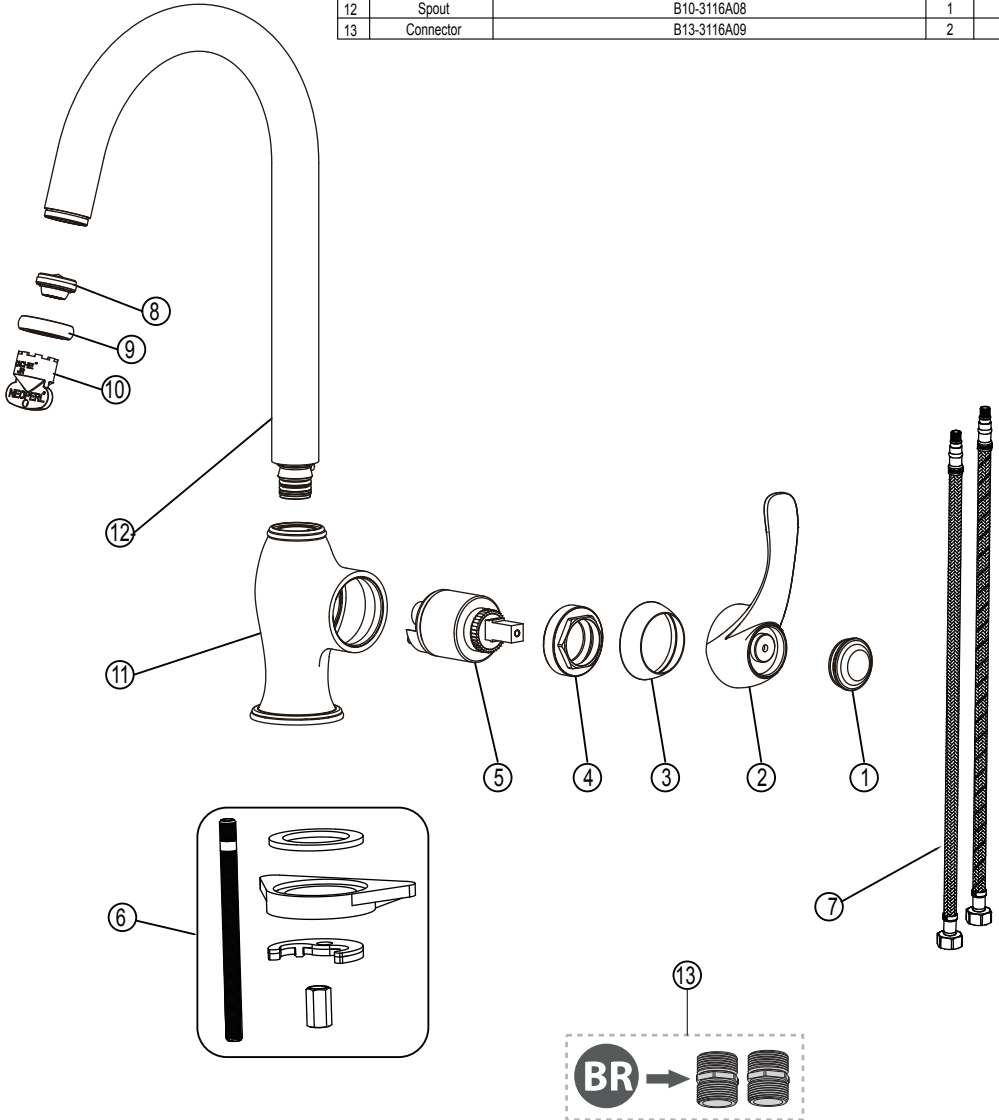







Certificado de conformidad sanitaria.  
Atestado de conformidade sanitária.  
certificato di conformità sanitaria.  
Βεβαίωση υγειονομικής συμμόρφωσης.  
Certyfikat zgodności sanitarnej.  
Декларация о соответствии санитарным нормам  
Санитарлық талаптарға сәйкестік декларациясы  
Декларация про відповідність санітарним нормам  
Atestat de conformitate sanitară  
Certificado de conformidade sanitária.  
Declaration of sanitary conformity.  
Attestation de conformité sanitaire

\* Garantie 10 ans / 10 años de garantía / Garantia de 10 años / Garanzia 10 Anni / Εγγύηση 10 ετών / Gwarancja 10-letnia / Гарантия 10 года / Кепілдік 10 жыл / Гарантія 10 років / Garantie 10 ani / 10 anos de garantia / 10-year guarantee

Made in P.R.C 2018

ADEO Services - 135 Rue Sadi Carnot - CS 00001  
59790 RONCHIN - France

**UA** ТОВ «Леруа Мерлен Україна»,  
вул. Полярна 17а, м. Київ 04201, Україна

