

## UNPACKING

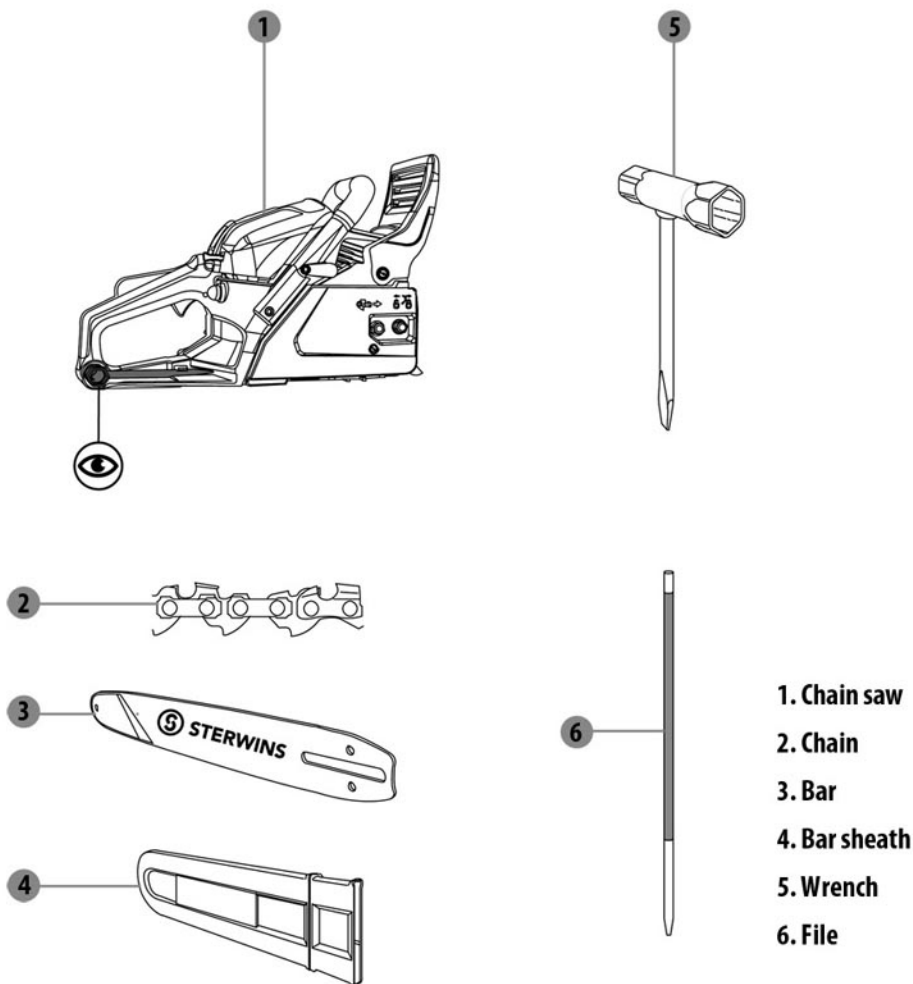

- Do not use any sharp tool (cutter, knife...) when unpacking, you may damage the product.
- Pay attention to the sharp blade of chain.
- Store away from furnaces, stoves, water heaters or other appliances that have pilot lights or other ignition sources because they can ignite fuel vapors.
- Risk of fire in case of dry vegetation in the neighborhood.
- The engine shall always be OFF when the machine is left on the ground.

## SYMBOLS



Complies with European standards: This symbol means that this appliance is compliant with the applicable European directives, and a test of compliance with these directives has been performed.



Ukrainian conformity marking



Green point : Packaging recycling.



Please read the operating instruction carefully before using the chain saw. Keep these operating instructions handy for future reference.



**WARNING!** For safety reasons, follow all the regulations in the instructions, if you fail to do that, it will result in serious bodily injury or machine damage.



Appropriate ear, eye, and head protection must be worn.



**Warning!** Danger of kickback. Beware of chain saw kickback and avoid contact with bar tip.



Do not use chain saw one-handed. Always use chain saw two-handed. Hold the chain saw with the right hand on the rear handle and the left hand on the front handle.



Always wear safety and anti-vibration(AV) gloves when operating the device.



Always wear safety and slip-resistant boots when operating the device.



Guaranteed sound power level for this equipment: 114 dB(A)



Push the front handle guard frontward to activate the chain brake.  
Pull the front handle guard rearward to release the chain brake.



Flipping the switch to the «STOP» position, immediately the engine stops.



Remove the spark plug before performing work.

## SYMBOLS



Beware of the thrown object.

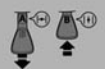

Pull out the choke knob, close the choke;  
push in the choke knob, open the choke.



Turn the adjuster follow the arrow to the «MAX» position, the chain oil flow more, and if you turn to the «MIN» position, oil flow less.



Shows the direction of the saw chain installation.



Shows the fuel tank, fuel mixture of gasoline and engine oil.



Shows the chain oil tank.

### The following symbols are used in this manual:



**Type and source of the danger:** Failure to observe this danger notice may cause physical injury or death.



**Type and source of the danger:** This danger notice warns of damage to the appliance, the environment or other property.



**Note:** This symbol signifies information that may help you reach a better understanding of the processes involved.

## CONTENTS

1. Intended and not intended use of chain saw
2. Safety Instructions
3. Description
4. Technical data
5. Trouble Shooting
6. Disposal and recycling
7. Warranty
8. Exploded view with parts list
9. CE Declaration

## 1. INTENDED AND NOT INTENDED USE OF CHAIN SAW

- This product is designed for use by a trained operator for forest service e.g. felling, cutting and limbing.
- The chain saw serves trunks, square timbers and for cutting branches, according to the available cutting length. Use your chain saw only for cutting wooden objects. It must not be used for any purposes other than those specified here.
- Suitable sawing chains, guide bars combinations may be used as mentioned in the operating instructions only for the machine. Do not use other types or sizes, serious damage or injuries may resulting from misapplication.
- Use the appropriate personal protective equipment (PPE) when using the chain saw.
- **WARNING!** National regulations (Occupational Safety and Health, environment) may be present, which can restrict the use of the chain saw.

## 2. SAFETY INSTRUCTIONS



**DANGER ! Exhaust gases contain dangerous carbon monoxide!**

Inhale the poisonous particle may cause death.

### Safety of the work area

- Operate the chain saw only in well ventilated areas. Never start or run the engine inside a closed room or building.
- Never use it for cutting in high wind, bad weather, when visibility is poor or in very high or low temperatures. Always check the tree for dead branches which could fall during the felling operation.
- Do not allow other persons to be near the chainsaw when starting the engine or cutting wood. Keep bystanders and animals out of the work area. Children, pets and bystanders should be a minimum of 30 feet (10m) away when you start or operate the chainsaw.

## 2. SAFETY INSTRUCTIONS

- Never start cutting until you have a clear work area, secure footing, and planned retreat path from the falling tree. These paths should be generally opposite to the planned direction of the fall of the tree and about at a 45° angle. Place all tools and equipment a safe distance away from the tree, but not on the escape paths.
- Eliminate all sources of sparks or flame (e.g. smoking, open flames, or work that can cause sparks) in the areas where fuel is mixed, poured, or stored.

### Personal safety

- Before using our products, please read this manual carefully to understand the proper use of your unit.
- Never operate a chain saw when you are tired, ill, or upset, or under the influence of medication that may make you drowsy, or if you are under the influence of alcohol or drugs.
- It is believed that a condition called Raynaud's phenomenon (white fingers), which affects the fingers of certain individuals may be brought about by exposure to vibration and cold. Loss of color and numbness in the fingers. The following precautions are strongly recommended:
  1. Wear the anti-vibration(AV) glove and keep your body warm, especially the head, neck, feet, ankles, hands and wrists.
  2. Maintain a firm grip at all times, but do not squeeze the handles with constant, excessive pressure.
  3. Maintain good blood circulation by performing vigorous arm exercises during frequent work breaks and also by not smoking.
  4. Keep the saw chain sharp and the saw, including the AV system, well maintained; A dull chain will increase cutting time, and pressing a dull chain through wood will increase the vibrations transmitted to your hands. A saw with loose components or with damaged or worn AV buffers will also tend to have higher vibration levels.

## 2. SAFETY INSTRUCTIONS

### 5. Limit the hours of operation.

All the above mentioned precautions do not guarantee that you will not sustain white finger disease or carpal tunnel syndrome. Therefore, continual and regular users should monitor closely the condition of their hands fingers.

If any of the above symptoms appear, seek medical advice immediately.

- Route noisy work is to be licensed and limits for certain periods. Wear an approved safety hard hat to reduce the risk of injury to your head. Chain saw noise may damage your hearing. Wear sound barriers (ear plugs or ear muffers) and limit the hours of operation to help protect your hearing. Be particularly alert and cautious when wearing hearing protection because your ability to hear warnings (shouts, alarms, etc.) is restricted. Operate your chain saw so that it produces a minimum of noise and emissions
  - limit the hours of operation.
  - do not run engine unnecessarily and accelerate the engine only for cutting.
  - do not use the chain saw with a damaged muffler or loosened parts, regularly check the machine by shaking it, if any abnormal sound from the machine, contact the local service for checking or/and repair.
- Sufficient personal protection equipment (PPE) is required according to the operating instructions during the use. Clothing must be sturdy and snug-fitting, but allow complete freedom of movement. To reduce the risk of cut injuries, wear the type of overalls, long pants or chaps that contain pads of cut-retardant material. Avoid loose-fitting jackets, scarfs, neckties, jewelry, flared or cuffed pants, unconfined long hair or anything that could become caught on branches, brush or the moving parts of the chain saw. Secure hair so it is above shoulder level. Wear sturdy and slip-resistant boots. Steel-toed safety boots are recommended. Always wear heavy-duty work gloves (e.g. made of leather or wear resistant material) when handling the chain saw and the cutting tool. To reduce the risk of injury to your eyes never operate your power tool unless wearing goggles or properly fitted protective glasses with adequate top and side protection. Wear an approved safety helmet to reduce the risk of injury to your head.

## 2. SAFETY INSTRUCTIONS

- Keep all parts of your body away from the saw chain when the engine is running. Before you start the engine, make sure the saw chain is not contacting anything. Always carry the chain saw with the engine stopped, the guide bar and saw chain to the rear, and the muffler away from your body.
- As soon as the engine is running, this product generates toxic exhaust fumes containing chemicals, such as unburned hydrocarbons (including benzene) and carbon monoxide, that are known to cause respiratory problems, cancer, birth defects, or other reproductive harm. Use of this chain saw (including sharpening the saw chain) can also generate dust, mist and fumes containing chemicals that are known to cause respiratory problems, cancer, birth defects, or other reproductive harm. Inhalation of certain dusts, especially organic dusts such as mold or pollen, can cause susceptible persons to have an allergic or asthmatic reaction. Always cutting with a properly sharpened saw chain (which produces wood chips rather than fine dust) and operating the unit so that the wind or operating process directs any dust raised by the chain saw away from the operator. The lubrication oil exhausted by the product will pollute the environment, so that you need clear the work area after the cutting or refuelling operation.

### Assembly and Start

- For the initial installation and tension of the guide bar and saw chain please refer to the assembly manual (p.4 - p.8). The saw chain has very sharp edges. Use the protection gloves when installing or tensioning the chain.
- Always inspect the chain saw before each use and after dropping or other impacts to identify significant damage or defects for worn, loose, or changed parts. Never operate a chain saw that is damaged, improperly adjusted, or is not completely and securely assembled.
- For the proper starting procedure, please refer to the assembly manual (p.14 - p.21). Make sure the chain brake is activated before each starting. Push the front handle guard toward the guide bar nose to activate the chain brake. Place

## 2. SAFETY INSTRUCTIONS

the chain saw on firm ground, grip the front handlebar of the saw firmly with your left hand and press down. For saws with a rear handle level with the ground, put the toe of your right foot into the rear handle and press down. With your right hand pull out the starter grip slowly until you feel a definite resistance and then give it a brisk, strong pull. When you pull the starter grip, do not wrap the starter rope around your hand. Do not let the grip snap back, but guide the starter rope to rewind it properly.



**Note:** Always disengage chain brake before accelerating engine and before starting cutting work. Otherwise, it can result in overheating and damage to important components (e.g. clutch, polymer housing components).

### Handling fuel and chain oil

- The engines are lubricated by oil specially formulated for air-cooled 2-cycle gasoline engine use. If oil is not available, use an antioxidant added quality oil expressly labeled for air-cooled 2-cycle engine use.

RECOMMENDED MIXING RATIO: GASOLINE 40 : OIL 1

- Take care when handling gasoline. Avoid direct contact with the skin and avoid inhaling fuel vapor. (Refer to assembly manual P.9-P.13).
- Use mid-grade unleaded gasoline with a minimum octane rating of 89 ((R+M)/2).
- Only mix sufficient fuel for a few days work, not to exceed 30days of storage. Store in approved fuel-containers only. When mixing,
  1. Measure out the quantities of gasoline and oil to be mixed.
  2. Put some of the gasoline into a clean, approved fuel container. Pour all of the oil in the fuel container. Pour the rest of gasoline in the oil container and agitate well, then pour the mixture in the fuel container.
  3. Agitate the fuel container for at least one minute. Put a clear indication on the

## 2. SAFETY INSTRUCTIONS

outside of the container to avoid confusing it for gasoline or other containers.



**The fuel is highly flammable. Do not smoke or bring any flame or sparks near fuel. Clean the fuel cap and the area around it.**

**FUEL WITH NO OIL (RAW GASOLINE) – It will cause severe damage to the engine inner parts very quickly. OIL FOR 4-CYCLE ENGINE USE or WATER COOLED 2-CYCLE ENGINE USE – It can cause spark plug fouling, exhaust port blocking, or piston ring sticking.**

- For automatic and reliable lubrication of the chain and guide bar – use only an environmentally compatible quality chain and bar lubricant.
- Do not use waste oil. Renewed contact with waste oil can cause skin cancer. Moreover, waste oil is environmentally harmful. waste or regenerated oil can cause damage to the oil pump.
- Refill the chain oil tank every time you refuel. Frequent checking and refilling of the oil tank is necessary. Take care not to spill chain oil during refilling and do not overfill the tank.

### Machine use and care

- The product is not designed for hedge trimming or cutting bundles of wood.
- Before starting work: Run engine at idle speed, engage the chain brake. Accelerate up to full throttle for no more than 3 seconds – the chain must not rotate. The front handle guard must be free from dirt and move freely.
- Be sure that the saw chain stops moving when the throttle control trigger is released. If the saw chain moving when the engine running at idle speed, contact with the local service for checking and repair.
- The spiked bumper belongs to the chain saw. It must be screwed up on chain saw before the initial use. Begin and continue cutting with the saw at full throttle, engage the bumper spike firmly in the wood (if possible) and then continue

## 2. SAFETY INSTRUCTIONS

cutting. Use a spiked bumper when cutting trees and thick branches can ensure your safety and decrease the working strength and vibration level.

- Always hold the chain saw firmly with both hands when the engine is running. Place your left hand on the front handle bar and your right hand on the rear handle. Use a firm grip with thumb and fingers encircling the chain saw handles.
- Keep hands and feet away from the cutting tool. Never touch a moving cutting tool with your hand or any other part of your body. Any other cutting positions should not be used with this products.
- Keep proper footing and balance at all times. Be extremely cautious when working on slopes or uneven ground. Never work on a ladder or any other insecure support. Never hold the machine above shoulder height. Do not overreach.
- Stand to the left of cut while bucking. Never put pressure on the chain saw when reaching the end of a cut. The pressure may cause the bar and rotating saw chain to pop out of the cut or kerf, go out of control and strike the operator or some other object. If the rotating saw chain strikes some other object, a reactive force may cause the moving saw chain to strike the operator.
- To reduce the risk of injury to bystanders and damage to property, never let your chain saw run unattended. When it is not in use (e.g. during a work break), shut it off and make sure that unauthorized persons do not use it.
- Do not operate your chain saw with the starting throttle lock engaged. Cutting with the starting throttle lock engaged does not permit the operator proper control of the chain saw or saw chain speed. Begin and continue cutting with the saw at full throttle.
- In the event of an emergency, switch off the engine immediately – move the Engine Switch to «STOP» or «0». Always stop the engine before putting the chain saw down or adjusting the guide bar and chain.
- The chain brake is a device which stops the chain instantaneously if the chain saw recoils due to kickback. Normally, the brake is activated automatically by inertial force. It can also be activated manually by pushing the front handle

## 2. SAFETY INSTRUCTIONS

guard down toward the front. To release brake, pull up the front handle guard toward the front handle till “click” sound is heard.

Be sure to confirm brake operation on the daily inspection. How to confirm:

- 1) Turn off the engine.
- 2) Holding the chain saw horizontally, release your hand from the front handle, hit the tip of the guide bar to a stump or a piece of wood, and confirm brake operation. Operating level varies by bar size.

In case the brake is not effective, ask our dealer inspection and repairing.

- Follow the assembly instructions (p.35-p.39) on lubricating, chain tensioning, maintenance and changing accessories. An improperly maintenance, tensioned or lubricated chain may either break or increase the risk of kickback.
- Never use the chain saw with one hand. It is more difficult for you to control reactive forces and to prevent the bar and chain from skating (slide unintentionally for a long distance) or bouncing (move quickly up, down, or away from the log) along the limb or log.
- Never put pressure on the chain saw when reaching the end of a cut. The pressure may cause the bar and rotating saw chain to pop out of the cut or kerf, go out of control and strike the operator or some other object.

### Causes of kickback and how to prevent it

Reactive forces may occur any time the chain is rotating. Reactive forces can cause serious personal injury. The powerful force used to cut wood can be reversed and work against the operator. If the rotating saw chain is suddenly and significantly slowed or stopped by contact with any solid object such as a log or branch or is pinched, the reactive forces may occur instantly. These reactive forces may result in loss of control, which, in turn, may cause serious or fatal injury. An understanding of the causes of these reactive forces may help you avoid the element of surprise and loss of control. Surprise contributes to accidents.

## 2. SAFETY INSTRUCTIONS

Rotational kickback can happen when the upper tip of the guide bar contacts an object while the chain is moving. This can cause the chain to dig into the object and momentarily stop moving. The guide bar is then kicked up and back toward the operator in a lightning-fast reverse reaction.

Linear kickback can happen when the wood on either side of a cut closes in and pinches the moving saw chain along the top of the guide bar. This can cause the chain to instantly stop. The chain force is then reversed, causing the saw to move in the opposite direction, sending the saw straight back toward the operator.

Either of these reactions may cause you to lose control of the saw which could result in serious personal injury. Do not rely exclusively upon the safety devices built into your saw. Many factors influence the occurrence and force of the kickback reaction. These include saw chain speed, the speed at which the bar and saw chain contact the object, the angle of contact, the condition of the saw chain and other factors. Kickback can be avoided by taking proper precautions as given below:

1. Hold the chain saw firmly with both hands and maintain a secure grip. Don't let go of the chain saw.
2. Be aware of the location of the guide bar nose at all times. Never let the nose of the guide bar contact any object. Do not cut limbs with the nose of the guide bar. Be especially careful near wire fences and when cutting small, tough limbs, small size brush and saplings which may easily catch the saw chain.
3. Don't overreach. Don't cut above shoulder height. Do not attempt to plunge cut if you are not experienced with these cutting techniques.
4. Begin cutting and continue at full throttle. Cut only one log at a time.
5. Use extreme caution when reentering a previous cut.
6. Be alert for shifting of the log or other forces that may cause the cut to close and pinch the saw chain.
7. Maintain saw chain properly. Cut with a correctly sharpened, properly tensioned saw chain at all times. Only use replacement bars and chains speci-

## 2. SAFETY INSTRUCTIONS

fied by the manufacturer. Incorrect replacement bars and chains may cause chain breakage and/ or kickback.

### Felling a tree

Refer to assembly manual page 29 to 30

When bucking and felling operations are being performed by two or more persons at the same time, the felling operations should be separated from the bucking operation by a distance of at least twice the height of the tree being felled. Trees should not be felled in a manner that would endanger any person, strike any utility line or cause any property damage. If the tree does make contact with any utility line, the company should be notified immediately. The noise of your engine may drown any warning call.

- The product operator should keep on the uphill side of the terrain as the tree is likely to roll or slide downhill after it is felled.
- An escape path should be planned and cleared as necessary before cuts are started. The escape path should extend back and diagonally to the rear of the expected line of fall.
- Before felling is started, consider the natural lean of the tree, the location of larger branches and the wind direction to judge which way the tree will fall.
- Remove dirt, stones, loose bark, nails, staples and wire from the tree.
- Notching undercut: Make the notch 1/3 the diameter of the tree, perpendicular to the direction of falls. Make the lower horizontal notching cut first. This will help to avoid pinching either the saw chain or the guide bar when the second notch is being made.
- Felling back cut: 1). Make the felling back cut at about 50 mm higher than the horizontal notching cut. Keep the felling back cut parallel to the horizontal notching cut. Make the felling back cut so enough wood is left to act as a hinge. The hinge wood keeps the tree from twisting and falling in the wrong direction. Do not cut through the hinge.  
2). As the felling gets close to the hinge, the tree should begin to fall. If there is

## 2. SAFETY INSTRUCTIONS

any chance that the tree may not fall in desired direction or it may rock back and wedges of wood, plastic or aluminium to open the cut and drop the tree along the desired line of fall.

- 3). When the tree begins to fall remove the product from the cut, stop the motor, put the product down, then use the retreat path planned. Be alert for overhead limbs falling and watch your footing.

### Limbing and bucking

Refer to assembly manual page 31 to 34

- Pull-in occurs when the saw chain on the bottom of the bar is suddenly stopped when it is pinched, caught or encounters a foreign object in the wood. The reaction of the saw chain pulls the chain saw forward and may cause the operator to lose control. Pull-in frequently occurs when the bumper spike of the chain saw is not held securely against the tree or limb and when the saw chain is not rotating at full speed before it contacts the wood.

Use extreme caution when cutting small size brush and saplings which may easily catch the saw chain, be whipped towards you or pull you off balance.

To avoid pull in:

1. Always start a cut with the saw chain rotating at full speed and the bumper spike in contact with the wood.
  2. The risk of pull-in may also be reduced by using wedges to open the kerf or cut.
- Pushback occurs when the saw chain on the top of the bar is suddenly stopped when it is pinched, caught or encounters a foreign object in the wood. The reaction of the saw chain may drive the chain saw rapidly straight back toward the operator and may cause loss of chain saw control, which, in turn, may cause serious or fatal injury. Pushback frequently occurs when the top of the bar is used for cutting. To avoid pushback:
    1. Be alert to forces or situations that may cause material to pinch the top of the saw chain. Do not cut more than one log at a time.
    2. Do not twist the chain saw when withdrawing the bar from a plunge cut or

## 2. SAFETY INSTRUCTIONS

underbuck cut because the saw chain can pinch.

- Limbing is removing the branches from a fallen tree. Start limbing by leaving the lower limbs to support the log off the ground. When underbucking freely hanging limbs, a pinch may result or the limb may fall, causing loss of control. If a pinch occurs, stop the engine and remove the saw by lifting the limb. Remove the small limbs in one cut. Branches under tension should be cut from the bottom up to avoid binding the product.
- Bucking is cutting a log into lengths. It is important to make sure your footing is firm and your weight is evenly distributed on both feet. When possible, the log should be raised and supported by the use of limbs, logs or chocks. Do not stand on the log. Make sure the log will not roll downhill. If on a slope, stand on the uphill side of the log. Watch out for rolling logs. Shattered wood should be cut very carefully. Sharp splinters of wood may be caught and flung in the direction of the operator of the saw. Don't let the chain contact the ground.
- Logs under strain: Risk of pinching! Always start relieving cut at compression side. Then make bucking cut at tension side. If the saw pinches, stop the engine and remove it from the log. Only properly trained professionals should work in an area where the logs, limbs and roots are tangled. Drag the logs into a clear area before cutting. Pull out exposed and cleared logs first.
- When the log is supported on one end, cut 1/3 the diameter from the underside (under buck). Then make the finished cut by over bucking to meet the first cut.
- When the log is supported on both ends, cut 1/3 the diameter from the top (over buck). Then make the finished cut by under bucking the lower 2/3 to meet the first cut.
- When "cutting through", to maintain complete control release the cutting pressure near the end of the cut without relaxing your grip on the product handles. Always stop the engine before moving from tree to tree.
- If the wood diameter is large enough for you to insert a soft bucking wedge without touching the chain, you should use the wedge to hold the cut open to prevent pinching.

## 2. SAFETY INSTRUCTIONS

- Support small logs on a sawing stand or another log while bucking.

### Maintenance

Refer to assembly manual page 35 to 45

PART	ACTION TO DO	BEFORE / AFTER EACH USAGE	EVERY 10H
AIR FILTER	CHECK	X	
	CLEAN		X
	CHANGE	WHEN IT'S NECESSARY / REFER TO TROUBLE SHOOTING	
SPARK PLUG	CHECK		X
	CLEAN		X
	CHANGE	WHEN IT'S NECESSARY / REFER TO TROUBLE SHOOTING	
GAZOLINE FILTER	CHECK	X	
	CLEAN		X
	CHANGE	WHEN IT'S NECESSARY / REFER TO TROUBLE SHOOTING	
CHAIN	CHECK	X	
	CLEAN	X	
	CHANGE	WHEN IT'S NECESSARY / REFER TO TROUBLE SHOOTING	
	GREASE	X	
	SHARP		X
CHAIN BAR	CHECK	X	
	CLEAN	X	
	CHANGE	WHEN IT'S NECESSARY / REFER TO TROUBLE SHOOTING	
	GREASE		X
RIM DRIVE SPROCKET	CHECK	X	
	CLEAN	X	
STARTER ROPE	CHECK	X	
	CHANGE	WHEN IT'S NECESSARY / REFER TO TROUBLE SHOOTING	

- Before cleaning, inspecting or maintenance your chain saw, make sure that engine has stopped and is cool. Follow the instructions to carry out regular maintenance, pre-operating procedures and daily maintenance routines. Use only the parts recommended by manufacturer. Never remove or modify the

## 2. SAFETY INSTRUCTIONS

safety components. Improper maintenance or using non-approved parts or modification of safety components may result in serious damage to the machine or personal injury.

- Before maintenance, consult the operator manual and remove the spark plug before performing any work.
- Keep the chain, bar and sprocket clean; replace worn sprockets or chains. Keep the chain sharp. You can spot a dull chain when easy-to-cut wood becomes hard to cut and burn marks appear on the wood. Keep the chain at proper tension.
- For the proper and effective operation of the chain brake, the brake band and clutch drum must be kept free of dirt, grease and other foreign matter which may reduce friction of the band on the drum. (refer to assembly manual p.35)
- It is very important to maintain the proper chain tension. Rapid wear of the guide bar or the chain coming off easily can be caused by improper tension. Especially when using a new chain, take good care of it since it should expand when first used. Check chain tension frequently.
- The saw chain must always throw off a small amount of oil. Never operate your saw without chain lubrication. If the chain runs dry, the whole cutting attachment will be irretrievably damaged within a very short time. Always check chain lubrication and the oil level in the tank before starting work. Regularly clean chain oil port and guide bar groove.
- Measure the groove depth – with the scale on the filing gauge (special accessory) – in the area used most for cutting. If groove depth is less than 6.0 mm. Replace the guide bar. The drive link tangs will otherwise scrape along the bottom of the groove – the cutters and tie straps will not ride on the bar rails.
- A properly sharpened saw chain cuts through wood effortlessly even with very little pushing. Never use a dull or damaged saw chain – this leads to increased physical strain, increased vibration load, unsatisfactory cutting results and increased wear. The diameter of file to be used is 4.0 mm. The angles of the cutter must be maintained during resharpening. Sharpening angle: 30°, Side

## 2. SAFETY INSTRUCTIONS

plate angle: 75°. File only from the inside outward. The file only sharpens on the forward stroke – lift the file on the backstroke. Do not file tie straps and drive links. Rotate the file a little periodically in order to avoid uneven wear. To remove file burr, use a piece of hardwood. Check angle with file gauge. All cutters must be equally long.



**The saw chain has very sharp edges. Always use protective gloves sharpening the saw chain.**

Fouled air filters will impair engine performance, increase fuel consumption and make the machine more difficult to start. Regularly clean the air filter with a brush or pressure air.

- The carburettor comes from the factory with a standard setting. The carburettor has been adjusted for optimum performance and fuel efficiency in all operating states. The carburettor shall be only adjusted by authorised person.
- If engine is down on power, difficult to start or runs poorly at idling speed, first check the spark plug. Fit a new spark plug after approx. 100 operating hours or earlier if the electrodes are badly eroded. Clean the spark plug if it is dirty. Check the electrode gap and readjust if necessary. The recommended clearance of the gap is 0.6-0.7 mm.
- Regularly check and clean the sprocket, needle bearing. All chain saw maintenance, other than the items listed in the operator's manual, should be performed by authorised person. (e.g., if improper tools are used to remove the flywheel, or if an improper tool is used to hold the flywheel in order to remove the clutch, structural damage to the flywheel could occur which could subsequently cause the flywheel to disintegrate).

## 2. SAFETY INSTRUCTIONS

### Transport and storage

Refer to assembly manual page 46 to 47

	WINTERING	HOT PRODUCT	COLD PRODUCT
LOCATION	Clean the bottom / Inside room / never under 0°C / cover it	Be careful, the chain oil can continue to flow / ventilated place/ never under 0 °C.	Clean the bottom / Inside room / never under 0°C
OIL TANK	Drain it	Let the product cool	Depressurize the tank (open and close the cap)
GAZOLINE TANK	Drain it	Let the product cool	Depressurize the tank (open and close the cap)
CHAIN	Remove / clean / Protect by the sleeve	Remove it / check the sharpening / Protect by the sleeve	Remove it / check the sharpening / Protect by the sleeve
CHAIN BAR	Remove / clean / Protect by the sleeve	Remove / clean / Protect by the sleeve	Remove / clean / Protect by the sleeve
AIR FILTER	Clean it	Check it	Check it

- Always stop the engine before putting the chain saw down. Always using the guide bar cover during transport and storage. Securely place the machine during transport to prevent loss of fuel, damage or injury.
- When transporting your chain saw by hand, the engine must be shut off and the chain saw must be in the proper position, i.e., grip the top handle and place the muffler away from the body; the guide bar cover (scabbard) should be over the saw chain and guide bar, which should point backwards, away from the direction in which you are walking.

## 2. SAFETY INSTRUCTIONS

- When transporting in a vehicle, keep saw chain and bar covered with the guide bar cover (scabbard). Properly secure your chain saw to prevent turnover, fuel spillage and damage to the chain saw.
- Before storing the power tools:
  1. Empty the fuel tank and run the engine out of fuel. Empty the oil tank.
  2. Thoroughly clean and maintain the entire unit.
  3. Store the unit in a dry place out of the reach of children.

### 3. DESCRIPTION

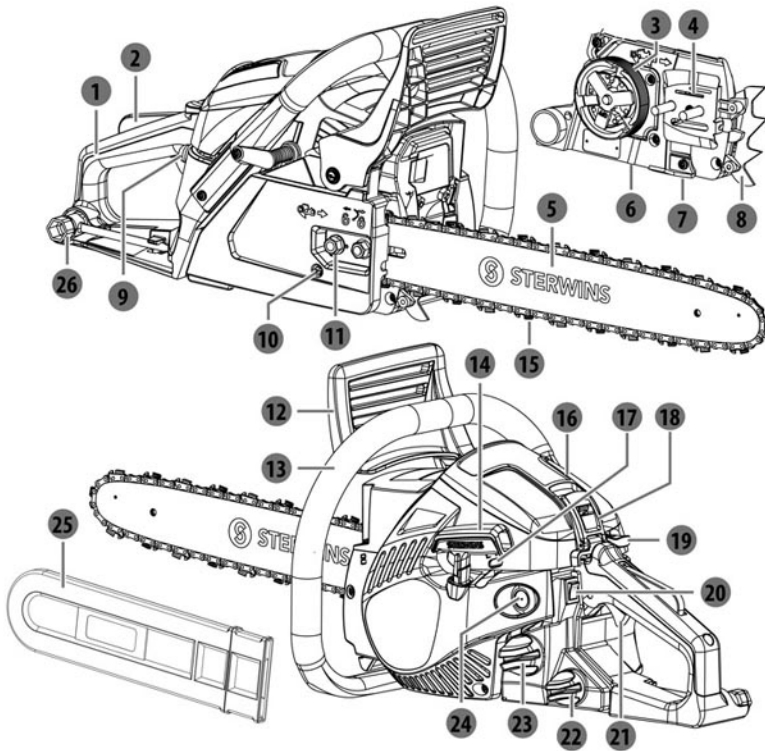

- 1 Rear handle
- 2 Throttle trigger lock-out
- 3 Clutch drum
- 4 Chain oil port
- 5 Guide bar
- 6 Oil flow adjuster
- 7 Chain catcher
- 8 Spiked bumper
- 9 Primer bulb
- 10 Chain tensioner
- 11 Lock nut
- 12 Front handle guard
- 13 Front handle

- 14 Starter handle
- 15 Saw chain
- 16 Air filter cover
- 17 Idle speed Screw
- 18 Lock lever
- 19 Choke knob
- 20 Switch
- 21 Throttle trigger
- 22 Oil tank cap
- 23 Fuel tank cap
- 24 Absorber
- 25 Guide bar cover
- 26 Spark plug wrench

## 4. TECHNICAL DATA

Model	PCS2-35.31	PCS2-40.31
Engine displacement	37.2 cm <sup>3</sup>	40.1 cm <sup>3</sup>
Max. engine power (in accordance with ISO 7293)	1.2 kW/1.6hp	1.45 kW/1.9hp
Max. no-load speed	12000 min <sup>-1</sup>	
Engine idling speed range	3000 ±400 min <sup>-1</sup>	
Fuel tank volume	320 cm <sup>3</sup>	
Oil tank volume	160 cm <sup>3</sup>	
Max. chain speed	22.86 m/s	
Drive sprocket	6T× 0,375"	
Weight (without guide bar and chain, empty tank)	4.7 kg	4.75 kg
Weight (with guide bar and chain, empty tank)	5.3 kg	5.4 kg
Type of gasoline	Gasoline 95 unleaded (Europe-US) Gasoline 92 unleaded (Russia)	
Spark plug	CHAMPION RCJ7Y	
Saw chain type	91P053X (Oregon)	91P057X(Oregon)
Specified pitch	9.525 mm (0.375 inches)	
Specified gauge	1.27 mm (0.050 inches)	
Guide bar type	140SDEA041(Oregon)	160SDEA041(Oregon)
Usable cutting length	33 cm(330 mm)	37 cm(370 mm)
Chain oil feed	Automatic mechanical pump	
Sound pressure level (in accordance with ISO 22868)	99.4 dB(A)	99.3 dB(A)
Uncertainty K	3 dB(A)	3 dB(A)
Sound power level (in accordance with ISO 22868)	109.2 dB(A)	109 dB(A)
Uncertainty K	3.0 dB(A)	3.0 dB(A)
Guareteed sound power level	114 dB(A)	114 dB(A)
Vibration (in accordance with ISO 22867)	front handle: 5.62 m/s <sup>2</sup> , rear handle: 6.86m/s <sup>2</sup>	front handle: 6.30m/s <sup>2</sup> , rear handle:7.43 m/s <sup>2</sup>
Uncertainty K	1.5 m/s <sup>2</sup>	

## 5. TROUBLESHOOTING



### **DANGER! Risk of injury due to accidental start.**

Warning! Before any troubleshooting, switch off the engine. Suspected malfunctions are often due to causes that users can fix themselves. Therefore check the product using this section. In most cases the problem can be solved quickly.

No engine start	Gazoline tank is empty	Fill the tank with a good mixt of gazoline and oil	CUSTOMER
	Gazoline tank is empty	Fill the tank with a new gazoline	CUSTOMER
	The gazoline strainer is not well placed (on the bottom)	Check its position or replace it	CUSTOMER
	The switch is on OFF position	Put the switch on ON positon	CUSTOMER
	The priming bulb has not been pressed enough	Press the priming bulb until the gazoline is visible inside (4-7 times)	CUSTOMER
	The spark plug is dirty	Remove and clean the electrode with a spark plug brush (iron bristle brush)	CUSTOMER
	The spark plug spring doesn't match with the plug	Remove and change the spark plug by a new one	CUSTOMER
	The spark plug is defective	Check is the spring is still on the cap. Otherwise change it by a new one	CUSTOMER

## 5. TROUBLESHOOTING

No engine start	The engine is flooded	Close the starter, remove the spark plug, clean the spark plug, return the machine and pull the rope 5 to 10 times to empty the cylinder of gasoline	CUSTOMER
	The gasoline pipe is drilled	Remove it and change it by a new one	AFTER SALES SERVICE
	The carburetor is not well adjusted	Resume the carburetor setting procedure from the beginning	AFTER SALES SERVICE
The engine lacks of power	The air filter is dirty	Clean it or replace it by a new one	CUSTOMER
	The spark plug is dirty	Remove and clean the electrode with a spark plug brush (iron bristle brush)	CUSTOMER
	The gasoline filter is blocked	Replace it by a new one	AFTER SALES SERVICE
	The carburetor speed screw is not well adjusted	Resume the carburetor setting procedure from the beginning	AFTER SALES SERVICE
Cutting performance is insufficient	The chain is not tense enough	Tense it correctly	CUSTOMER
	The chain is dull / damaged	Sharpen it or change it by a new one	CUSTOMER
	Lubricant oil tank is empty	Fill it or adjust the oil consumption when it's possible	CUSTOMER

## 5. TROUBLESHOOTING

Vibration	The chain is dull / damaged	Sharpen it or change it by a new one	CUSTOMER
	Nuts / screws are not well tight	Screw the nut(s) / screw(s)	CUSTOMER
Excessive noise	Nuts / screws are not well tight	Screw the nut(s) / screw(s)	CUSTOMER
The engine doesn't go to the idle speed	Gazoline filter is blocked	Replace it by a new one	AFTER SALES SERVICE
	The carburetor idle speed screw is not well adjusted	Resume the carburetor setting procedure from the begining	AFTER SALES SERVICE
No engine stop	The OFF switch is defective	Test it and change it by a new one	AFTER SALES SERVICE
	The brake system is defective	Test it and change it by a new one	AFTER SALES SERVICE
	The trigger system is defective	Test it and change it by a new one	AFTER SALES SERVICE
	The carburetor is defective	Test it and change it by a new one	AFTER SALES SERVICE

## 5. TROUBLESHOOTING

Overconsumption	Carburetor is not well adjusted /	Resume the carburetor setting procedure from the beginning	AFTER SALES SERVICE
	There is a leak of gasoline due to a defective assembly (drilled pipe/bad connection)	Find the leak location and replace the part by a new one	AFTER SALES SERVICE
	There is a leak of oil due to a defective assembly (drilled pipe/bad connection)	Find the leak location and replace the part by a new one	AFTER SALES SERVICE
Loss of the chain	The blade is not the good one in terms of dimension	The customer needs to check the instruction manual to identify the good chain / guide	CUSTOMER
	The chain is not tight enough	Tighten it thanks to the chain tightening screw	CUSTOMER
	The blade cover is not well put	Remove the cover and pay attention to put on the good position and tighten it enough	CUSTOMER

## 5. TROUBLESHOOTING

Chain breakage	The chain is too tight	Unscrew the chain tightening screw	CUSTOMER
	The chain is not lubricated enough	Check if the oil tank is not empty and fill it	CUSTOMER
		The oil pump is defective, change it	AFTER SALES SERVICE
		Check the setting of the oil consumption and adjust it	CUSTOMER
	The chain is wasted	Remove it and change it by a new one	CUSTOMER
Chain driven at engine start	One step of the starting process has been forgotten	Put a trigger	CUSTOMER
	The trigger is blocked on ON position	Remove the trigger cover and replace it by a new one	AFTER SALES SERVICE

## 5. TROUBLESHOOTING

Oil leak	There is a leak of oil lubricant due to a defective assembly (drilled pipe/bad connection)	Find the leak location and replace the part by a new one	AFTER SALES SERVICE
	The lubricant oil continues to flow by capillarity	Check with the after sales service if the oil pump is not damaged. Otherwise it's normal, let the chainsaw cool while protecting the ground (cardboard, towel ...)	CUSTOMER
Gazolin leak	There is a leak of gasoline due to a defective assembly (drilled pipe/bad connection)	Find the leak location and replace the part by a new one	AFTER SALES SERVICE
Chain guide breakage	The blade cover is not well put	Remove the cover and pay attention to put on the good position and tight it enough	CUSTOMER

## 5. TROUBLESHOOTING

Chain does not stop on released trigger	The trigger is blocked on ON position	Remove the trigger cover and replace it by a new one	AFTER SALES SERVICE
	The guide has been stucked on a branch	Pay attention to initiate the cup by 3-4 cm blow tha brach and then cut it from above	AFTER SALES SERVICE
	The carburetor is blocked on ON position	Remove the trigger cover and replace it by a new one	AFTER SALES SERVICE
Wood splatter projection	The chain is blunt	Sharpen it or change it by a new one	CUSTOMER
	The chain is wasted	Remove it and change it by a new one	CUSTOMER
Chain untight during use	The chain is wasted	Remove it and change it by a new one	CUSTOMER
	The tightening system is wasted	Remove it and change it by a new one	AFTER SALES SERVICE
	The chain/guide is not well placed	Remove it and adjust it	CUSTOMER

## 5. TROUBLESHOOTING

The starter rope is blocked	The inside spring is broken	Remove it and change it by a new one	AFTER SALES SERVICE
	A part of the machine block it (ex. screw unscrewed because of vibration)	Find the blocking part and fix it	AFTER SALES SERVICE
	The motor is out of usage	Remove it and change it by a new one	AFTER SALES SERVICE
The starter rope is broken	The inside spring was wasted	Remove it and change it by a new one	AFTER SALES SERVICE
	The user put it too strongly and broke it	Remove it and change it by a new one	AFTER SALES SERVICE
	The engine is about to be out of usage	Remove it and change it by a new one	AFTER SALES SERVICE

## 6. DISPOSAL AND RECYCLING



Never pour remainders of chain lubricant or 2-stroke fuel mixture in the drain or sewerage system or soil, but dispose of it in a proper, environmentally friendly way, e.g., at a special collecting point or dump.

If your device should become useless somewhere in the future or you do not need it any longer, do not dispose of the device together with your domestic refuse, but dispose of it in an environmentally friendly manner. Thoroughly empty the oil/lubricant and fuel tanks and dispose of the remainders at a special collecting point or dump. Please also dispose of the device itself at an according collecting/recycling point. By doing so, plastic and metal parts can be separated and recycled. Information concerning the disposal of materials and devices are available from your local administration.

## 7. WARRANTY

1. STERWINS products are designed to highest DIY quality standards. STERWINS offer a 36-month warranty for its products, from the date of purchase. This warranty applies to all material and manufacturing defects which may arise. No further claims are possible, of whatever nature, direct or indirect, relating to people and/or materials.
2. In the event of a problem or defect, you should first always consult your STERWINS dealer. In most cases, the STERWINS dealer will be able to solve the problem or correct the defect.
3. Repairs or the replacement of parts will not extend the original warranty period.
4. Defects which have arisen as a result of improper use or wear are not covered by the warranty. Amongst other things, this relates to switches, protective circuit switches and motors, in the event of wear.
5. **Your claim upon the warranty can only be processed if:**
  - Proof of the purchase date can be provided in the form of a receipt
  - No repairs and/or replacements have been carried out by third parties
  - The tool has not been subjected to improper use (overloading of the machine or fitting non-approved accessories).
  - There is no damage caused by external influences or foreign bodies such as sand or stones.
  - There is no damage caused by non-observance of the safety instructions and the instructions for use.
6. The warranty stipulations apply in combination with our terms of sale and delivery.
7. Faulty tools to be returned to STERWINS via your STERWINS dealer will be collected by STERWINS as long as the product is properly packaged. If faulty goods are sent directly to STERWINS by the consumer, STERWINS will only be able to process these goods if the consumer pays the shipping costs.
8. Products which are delivered in a poorly packaged condition will not be accepted by STERWINS.

## 8. EXPLODED VIEW WITH PARTS LIST (ENGINE UNIT)

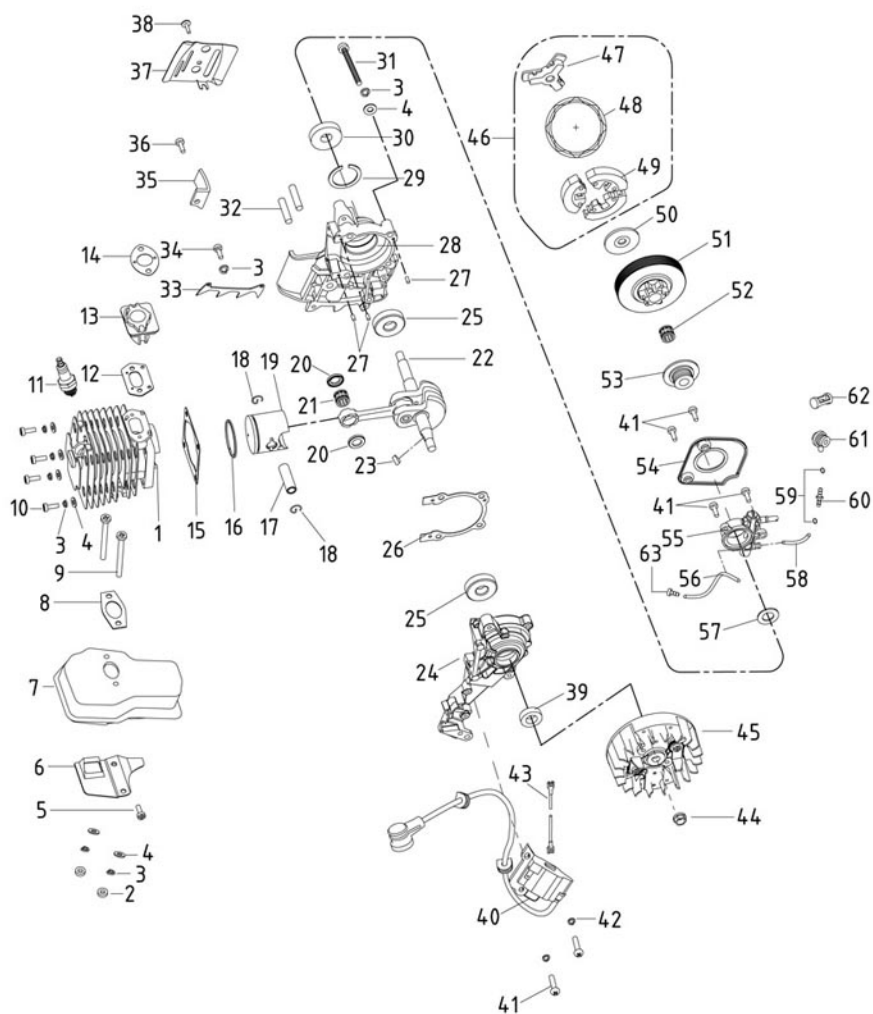

## 8. EXPLODED VIEW WITH PARTS LIST (ENGINE UNIT)

Part No.	Description	Part No.	Description
1	Cylinder	46	Centrifugal clutch
2	Nut M5	47	Retainer
3	Spring washer 5	48	Clutch spring
4	Plate washer 5	49	Shoe block
5	Screw M5×14	50	Clutch washer
6	Muffler cover	51	Clutch drum
7	Muffler	52	Needle bearing 10×13×13
8	Muffler gasket	53	Worm gear
9	Muffler screw	54	Oil pump cover
10	Screw M5×20	55	Oil pump
11	Spark plug	56	Oil spray tube 3×6.5×75
12	Gasket for intake pipe	57	Worm washer 10×18×1
13	Intake pipe	58	Oil supply tube 3×6.5×68
14	Gasket for carburettor	59	Oil tube circlip
15	Cylinder gasket	60	Oil tube joint
16	Piston ring	61	Oil nozzle
17	Piston pin	62	Oil filter screen
18	Piston pin circlip	63	Oil spray nozzle
19	Piston		
20	Anti-friction washer		
21	Needle bearing 10×14×11		
22	Crankshaft		
23	Semicircular key 3×3.5×10		
24	Left crankcase		
25	Ball bearing 6201		
26	Crankcase gasket		
27	Pin 3×9		
28	Right crankcase		
29	Circlip for hole 32		
30	Oil seal 12×32×5.5		
31	Screw M5×30		
32	Bolt AYM8×26		
33	Spiked bumper		
34	Screw M5×12		
35	Chain catcher		
36	Chain catcher screw		
37	Oil port cover		
38	Screw M4×10		
39	Oil seal 12×22×7		
40	Igniter		
41	Screw M4×14		
42	Spring washer 4		
43	Interrupting wire		
44	Nut M8×1		
45	Magnetor		

## 8. EXPLODED VIEW WITH PARTS LIST (ENCLOSER UNIT)

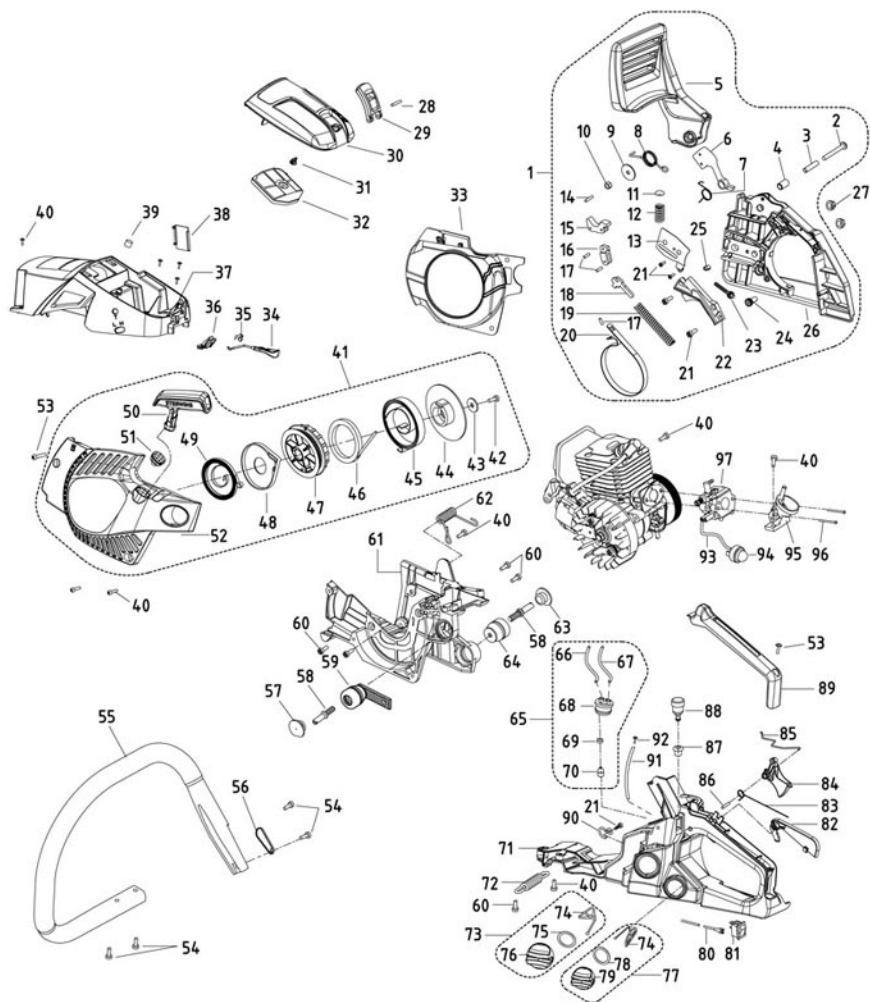

## 8. EXPLODED VIEW WITH PARTS LIST (ENCLOSER UNIT)

Part No.	Description	Part No.	Description	Part No.	Description
1	Clutch cover assembly	46	Starter rope	91	Vent tube 3.5×6.5×72
2	Screw M5×40	47	Rope roll	92	Tapping screw ST4.2×14
3	Pipe bushing 5×6.3×30	48	Bottom coil spring cover	93	Fuel pump tube
4	Bushing 6.3×9×15	49	Bottom coil spring	94	Primer bulb
5	Front handle guard	50	Starter handle	95	Air intake pipe
6	Heavy block	51	Jacket	96	Carburettor screw
7	Heavy block spring	52	Starter cover	97	Carburettor
8	Torsion rod spring	53	Tapping screw ST4.8×19		
9	Washer 5.2×20×1.2	54	Tapping screw ST4.8×25		
10	Nut M5	55	Front handle		
11	Spring base	56	Torsion rod spring cover		
12	Support spring	57	Left anti-dust cover		
13	Tensioner cover	58	Spiked bolt		
14	Pin 3×14	59	Left absorber		
15	Main lever	60	Screw M5×14		
16	Secondary lever	61	Engine base		
17	Pin 3×9	62	Front handle spring		
18	Brake connect rod	63	Right anti-dust cover		
19	Brake spring	64	Right absorber		
20	Brake strap	65	Fuel supply assembly		
21	Tapping screw ST4.2×9.5	66	Fuel supply tube		
22	Brake spring cover	67	Scavenge pipe		
23	Chain tension screw	68	Fuel tube root		
24	Chain tension block	69	Weight block		
25	Chain tension gear	70	Fuel filter		
26	Clutch cover	71	Rear handle		
27	Nut M8	72	Rear handle spring		
28	Pin 3×31	73	Fuel tank cap assembly		
29	Lock lever	74	Retainer		
30	Air filter cover	75	O ring 24.7×3.65		
31	Air filter lock nut	76	Fuel tank cap		
32	Air filter	77	Oil tank cap assembly		
33	Air flow guide cover	78	O ring 20×3.1		
34	Choke knob	79	Oil tank cap		
35	Cushion for choke knob	80	Ground wire		
36	Anti-dust shield	81	Switch		
37	Cylinder shield	82	Throttle trigger lock-out		
38	Anti-freeze block	83	Trigger torsion rod spring		
39	Anti-vibration cushion	84	Throttle trigger		
40	Tapping screw ST4.8×16	85	Throttle rod		
41	Starter assembly	86	Pin 5×24		
42	Tapping screw ST4.8×13	87	Vent valve seat		
43	Plate washer 5	88	Vent valve assembly		
44	Starter ratchet	89	Rear handle cover		
45	Top coil spring	90	Circlip for oil nozzle		





**EU/EC Declaration of conformity**  
**Déclaration UE/CE de conformité**  
**DECLARACIÓN CE / UE DE CONFORMIDAD**  
**Declaração CE/UE de conformidade**

ENFR  
ESPT



Product Model/Modèle du produit/Modelo de producto/Modelo do produto]

**840276**

Name and address of the manufacturer or his authorised representative/Nom et adresse du fabricant ou de son mandataire/Nombre y dirección del fabricante o de su representante autorizado/Nome e endereço do fabricante ou do seu representante autorizado]

**ADEO Services, 135 Rue Sadi Carnot - CS 00001 59790 RONCHIN - France**

This declaration of conformity is issued under the sole responsibility of the manufacturer/La présente déclaration de conformité est établie sous la seule responsabilité du fabricant/La presente declaración de conformidad se expide bajo la exclusiva responsabilidad del fabricante/Esta declaração de conformidade é emitida sob a exclusiva responsabilidade do fabricante.]

**Object of the declaration/Objet de la déclaration/Objeto de la declaración/Objeto da declaração]**

Product Type - Description/Type de produit - Description/Tipo de producto [Tipo de producto ]

**STERWINS GASOLINE CHAIN SAW, 37.2CC, 35CM**

Product Reference/Référéncie produit/Referencia del producto/Referência do produto:]

**840276 - EAN Code: 3276000696452**  
**Industrial Type Design Reference: PCS2-35.31**

Product Brand/Marque Produit/Producto de marca/Marca do produto]

**STERWINS**

Serial number coding or batch number/Codification du numéro de série ou de lot/Codificação do número de serie/Codificação do número de série]

**SN SSSSSS XX DDDMMYY nn PPPPPP (SN: Serial No., SSSSSS : Supplier code, XX : Factory ID, DDDMMYY: Production date, nn: number of version of product, PPPPPP : Incremental number)**

The object of the declaration described above is in conformity with the relevant Union harmonization legislation/L'objet de la déclaration décrit ci-dessus est conforme à la législation d'harmonisation de l'Union applicable/El objeto de la declaración descrita anteriormente es conforme a la legislación de armonización pertinente de la Unión/O objeto da declaração acima descrita está em conformidade com a legislação de harmonização da União aplicável:]

References to the relevant harmonised standards used or references to the specifications in relation to which conformity is declared/Références des normes harmonisées pertinentes appliquées ou des spécifications par rapport auxquelles la conformité est déclarée/Referencias a las normas armonizadas pertinentes utilizadas, o referencias a las especificaciones respecto a las cuales se declara la conformidad/Referências às normas harmonizadas pertinentes utilizadas ou referências às especificações para as quais a conformidade é declarada]

When applicable, the name and number of notified body number/Le cas échéant, le nom et le numéro de l'organisme notifié/Quando corresponder " el nombre y número de laboratorio notificado que haya emitido la certificación y la referencia al documento/Quando aplicável " o nome e número do laboratório notificado que emitiu a certificação e uma referência ao documento]

**2006\_42\_EC\_MACHINE  
machinery/Machines/máquinas [máquinas]**

**EN ISO 11681-1:2011**

Verification No.: MD-295 Issue 1  
released by SGS Fimko Ltd, Takomtie 8,00380  
HELSINKI, Finland  
NB number:0598

**2014\_39\_EU EMC  
Electromagnetic compatibility/compatibilité  
électromagnétique/compatibilidad electromagnética [compatibilidade  
eletromagnética ]**

**EN ISO 14982:2009**

**(EU)2015/863 amending Directive 2011/65/EU**

**2011\_65\_EU RoHS  
Restriction of hazardous substances in electrical products/Restriction  
des substances dangereuses dans les produits électriques/Restricción  
de sustancias peligrosas en equipos eléctricos./Restrição de  
substâncias perigosas em equipamentos elétricos]**

**IEC 62321-4:2013**  
**IEC 62321-5:2013**  
**IEC 62321-6:2015**  
**IEC 62321-7-1:2015**  
**IEC 62321-7-2:2017**  
**EN ISO 17075-1:2017**  
**IEC 62321-8:2017**  
**EN IEC 63000:2018**

**2000\_14\_EC\_NOISE  
noise emission/ émissions sonore/emisiones sonoras [emissões  
sonoras]**

**2000/14/EC, Annex V & 2005/88/EC**  
**ISO 22868:2021**  
**EN ISO 3744:1995**

Measured sound power level:110.9dB(A),  
Guaranteed sound power level:114dB(A)

Signed for and on behalf of/Signé par et au nom de/Firmado por y en nombre de/Assinado por e em nome de:]

**Eric LEMONE**  
**International Project Quality Leader**

Place and date of issue/Date et lieu d'établissement/Lugar y fecha de expedición/Local e data de emissão]

**Ronchin**  
**29/03/2022**

**ADEO Services SAS**  
**135 Rue Sadi Carnot**  
**CS 00001**  
**59790 RONCHIN**



**DICHIARAZIONE DI CONFORMITÀ CE / UE  
DEKLARACJA ZGODNOŚCI WE / UE  
ΔΗΛΩΣΗ ΣΥΜΜΟΡΦΩΣΗΣ ΕΚ / ΕΕ  
DECLARAȚIA CE / UE DE CONFORMITATE**



IT/POI  
GR/RO

Modelo di prodotto/prodotto/Model produktu/produkt|Μοντέλο προϊόντος/Προϊόν|Modelul de produs/produsul|

**840276**

La presente dichiarazione di conformità è rilasciata sotto la responsabilità esclusiva del fabbricante|Niniejsza deklaracja zgodności wydana zostaje na wyłączną odpowiedzialność producenta.|Επισημαίνεται ότι η δήλωση του κατασκευαστή ή του εξουσιοδοτημένου αντιπροσώπου του|Denumirea și adresa producătorului sau a reprezentantului său autorizat|.

**ADEO Services, 135 Rue Sadi Carnot - CS 00001 59790 RONCHIN - France**

La presente dichiarazione di conformità è rilasciata sotto la responsabilità esclusiva del fabbricante|Niniejsza deklaracja zgodności wydana zostaje na wyłączną odpowiedzialność producenta.|Η δήλωση της συμμόρφωσης εκδίδεται με αποκλειστική ευθύνη του κατασκευαστή|Declarația de conformitate este emisă pe răspunderea exclusivă a producătorului|

**Objeto de la declaración|Przedmiot deklaracji|Στόχος της δήλωσης|Obiectul declarației|**

Tipologia di prodotto/Rodzaj produktu|Τύπος Προϊόντος|Tip produs|

**STERWINS GASOLINE CHAIN SAW, 37.2CC, 35CM**

Riferimento del prodotto/Referențe produs|Αναφορά προϊόντος|Referință produs|

**840276 - EAN Code: 3276000696452  
Industrial Type Design Reference: PCS2-35.31**

Marca del prodotto/Marka produsului|Μάρκα προϊόντος|Marcă a produsului|

**STERWINS**

Codifica del numero di serie/Kodowanie numeru serijnego|Κωδικοποίηση αριθμικού αριθμού|Cod de numere de serie|

**SN SSSSSS XX DDMMYY nn PPPPPP (SN: Serial No., SSSSSS : Supplier code, XX : Factory ID, DDMMYY: Production date, nn: number of version of product, PPPPPP : Incremental number)**

L'oggetto della dichiarazione di cui sopra è conforme alla pertinente normativa di armonizzazione dell'Unione|Wymieniony powyżej przedmiot niniejszej deklaracji jest zgodny z odnoszonymi wymaganiami unijnego prawodawstwa harmonizacyjnego|Ο στόχος της δήλωσης που περιγράφεται παραπάνω είναι σύμφωνος με τη σχετική ενωσιακή νομοθεσία ενσωμάτωσης|Obiectul declarației descris mai sus este în conformitate cu legislația comunitară relevantă de armonizare a Uniunii|

Riferimenti alle pertinenti norme armonizzate utilizzate o alle specifiche in relazione alle quali è dichiarata la conformità|Odnosiťnia do odnošných norm zharmonizovaných, ktoré zastosovano, lub do špecifikáci, w odniesieniu do których deklarowana jest zgodność|Μνεία των σχετικών ενσωματωμένων προτύπων που χρησιμοποιούνται ή μνεία των προδιαγραφών σε σχέση με τις οποίες δηλώνεται η συμμόρφωση|Referințele standardelor armonizate relevante folosite sau referințele specificatorilor în legătură cu care se declară conformitatea|

Dove applicabile \* il nome e il numero del laboratorio notificato che ha rilasciato la certificazione e il riferimento al documento|W stosownych przypadkach \* należy podać nazwa i numer laboratorium, które wydało certyfikat oraz odniesienie do dokumentu|Όπου ισχύει \* το γινωστοποιημένο όνομα και τον αριθμό του εργαστηρίου που εξέδωσε την πιστοποίηση και την αναφορά στο έγγραφο|Unde este cazul \* numele și numărul de laborator notificat care a eliberat certificarea și trimiterea la document|

**2006\_42\_EC\_MACHINE  
macchine|maszyny|σχετικά με τα μηχανήματα|echipamentele tehnice|**

**EN ISO 11681-1:2011**

Verification No.: MD-295 Issue 1  
released by SGS Fimko Ltd, Takomotie 8,00380  
HELSINKI, Finland  
NB number:0598

**2014\_30\_EU EMC  
compatibilitate electromagnetica|kompatybilności elektromagnetycznej|ηλεκτρομαγνητική συμβατότητα|compatibilitatea electromagnetica|**

**EN ISO 14982:2009**

**2011\_65\_EU RoHS  
Restrizione di sostanze pericolose nelle apparecchiature elettriche|Ograniczenie niebezpiecznych substancji w sprzęcie elektrycznym|Περιορισμός επικίνδυνων ουσιών σε ηλεκτρικό εξοπλισμό|Restricționarea substanțelor periculoase în echipamentele electrice|**

**(EU)2015/863 amending Directive 2011/65/EU  
IEC 62321-4:2013  
IEC 62321-5:2013  
IEC 62321-6:2015  
IEC 62321-7-1:2015  
IEC 62321-7-2:2017  
EN ISO 17075-1:2017  
IEC 62321-8:2017  
EN IEC 63000:2018**

**2000\_14\_EC NOISE  
emissione acustica|emisija akustyczna|ακουστική έκδοση|emisie acustică|**

**2000/14/EC, Annex V & 2005/88/EC  
ISO 22868:2021  
EN ISO 3744:1995**

Measured sound power level:110.9dB(A),  
Guaranteed sound power level:114dB(A)

Firmato in vece e per conto di|Podpisano w imieniu|Υπογραφή για και εξ ονόματος|Semnat pentru și în numele|

**Eric LEMOINE  
International Project Quality Leader**

Luogo e data del rilascio|Data wydania i miejsce|Τόπος και ημερομηνία έκδοσης|

**Ronchin  
29/03/2022**

**ADEO Services SAS  
135 Rue Sadi Carnot  
CS 00001  
59790 RONCHIN**



**EU/EC Declaration of conformity**  
**Déclaration UE/CE de conformité**  
**DECLARACIÓN CE / UE DE CONFORMIDAD**  
**Declaração CE/UE de conformidade**

ENFR  
ESPT



Product Model/Modèle du produit/Modelo de producto/Modelo do produto]

**840277**

Name and address of the manufacturer or his authorised representative/Nom et adresse du fabricant ou de son mandataire/Nombre y dirección del fabricante o de su representante autorizado/Nome e endereço do fabricante ou do seu representante autorizado]

**ADEO Services, 135 Rue Sadi Carnot - CS 00001 59790 RONCHIN - France**

This declaration of conformity is issued under the sole responsibility of the manufacturer/La présente déclaration de conformité est établie sous la seule responsabilité du fabricant/La presente declaración de conformidad se expide bajo la exclusiva responsabilidad del fabricante/Esta declaração de conformidade é emitida sob a exclusiva responsabilidade do fabricante.]

**Object of the declaration/Objet de la déclaration/Objeto de la declaración/Objeto da declaração]**

Product Type - Description/Type de produit - Description/Tipo de producto [Tipo de producto ]

**STERWINS GASOLINE CHAIN SAW, 40.1CC, 40CM**

Product Reference/Référence produit/Referencia del producto/Referência do produto:]

**840277 - EAN Code: 3276000696445**  
**Industrial Type Design Reference: PCS2-40.31**

Product Brand/Marque Produit/Producto de marca/Marca do produto]

**STERWINS**

Serial number coding or batch number/Codification du numéro de série ou de lot/Codificação do número de serie/Codificação do número de série]

**SN SSSSSS XX DDDMMYY nn PPPPPP (SN: Serial No., SSSSSS : Supplier code, XX : Factory ID, DDDMMYY: Production date, nn: number of version of product, PPPPPP : Incremental number)**

The object of the declaration described above is in conformity with the relevant Union harmonization legislation/L'objet de la déclaration décrit ci-dessus est conforme à la législation d'harmonisation de l'Union applicable/El objeto de la declaración descrita anteriormente es conforme a la legislación de armonización pertinente de la Unión/O objeto da declaração acima descrita está em conformidade com a legislação de harmonização da União aplicável:]

References to the relevant harmonised standards used or references to the specifications in relation to which conformity is declared/Références des normes harmonisées pertinentes appliquées ou des spécifications par rapport auxquelles la conformité est déclarée/Referencias a las normas armonizadas pertinentes utilizadas, o referencias a las especificaciones respecto a las cuales se declara la conformidad/Referências às normas harmonizadas pertinentes utilizadas ou referências às especificações para as quais a conformidade é declarada]

When applicable, the name and number of notified body number/Le cas échéant, le nom et le numéro de l'organisme notifié/Quando corresponder " el nombre y número de laboratorio notificado que haya emitido la certificación y la referencia al documento/Quando aplicável " o nome e número do laboratório notificado que emitiu a certificação e a referência ao documento]

**2006\_42\_EC\_MACHINE  
machinery/Machines/máquinas [máquinas]**

**EN ISO 11681-1:2011**

Verification No.: MD-295 Issue 1  
released by SGS Fimko Ltd, Takomotte 8,00380  
HELSINKI, Finland  
NB number:0598

**2014\_30\_EU EMC  
Electromagnetic compatibility/compatibilité  
électromagnétique/compatibilidad electromagnética [compatibilidade  
eletromagnética ]**

**EN ISO 14982:2009**

**(EU)2015/863 amending Directive 2011/65/EU**

**2011\_65\_EU RoHS  
Restriction of hazardous substances in electrical products/Restriction  
des substances dangereuses dans les produits électriques/Restricción  
de sustancias peligrosas en equipos eléctricos./Restrição de  
substâncias perigosas em equipamentos elétricos]**

**IEC 62321-4:2013**  
**IEC 62321-5:2013**  
**IEC 62321-6:2015**  
**IEC 62321-7-1:2015**  
**IEC 62321-7-2:2017**  
**EN ISO 17075-1:2017**  
**IEC 62321-8:2017**  
**EN IEC 63000:2018**

**2000\_14\_EC\_NOISE  
noise emission/ émissions sonore/emisiones sonoras [emissões  
sonoras]**

**2000/14/EC, Annex V & 2005/88/EC**  
**ISO 22868:2021**  
**EN ISO 3744:1995**

Measured sound power level:110.8dB(A),  
Guaranteed sound power level:114dB(A)

Signed for and on behalf of/Signé par et au nom de/Firmado por y en nombre de/Assinado por e em nome de:]

**Eric LEMONE**  
**International Project Quality Leader**

Place and date of issue/Date et lieu d'établissement/Lugar y fecha de expedición/Local e data de emissão]

**Ronchin**  
**29/03/2022**

**ADEO Services SAS**  
**135 Rue Sadi Carnot**  
**CS 00001**  
**59790 RONCHIN**



**DICHIARAZIONE DI CONFORMITÀ CE / UE  
DEKLARACJA ZGODNOŚCI WE / UE  
ΔΗΛΩΣΗ ΣΥΜΜΟΡΦΩΣΗΣ ΕΚ / ΕΕ  
DECLARAȚIA CE / UE DE CONFORMITATE**

IT/POI  
GR/RO



Modelo di prodotto/prodotto/Model produktu/produkt|Μοντέλο προϊόντος/Προϊόν|Modelul de produs/produsul|

**840277**

La presente dichiarazione di conformità è rilasciata sotto la responsabilità esclusiva del fabbricante|Niniejsza deklaracja zgodności wydana zostaje na wyłączną odpowiedzialność producenta.|Επιτυμμία και διεύθυνση του κατασκευαστή ή του εξουσιοδοτημένου αντιπροσώπου του|Denumirea și adresa producătorului sau a reprezentantului său autorizat.}

**ADEO Services, 135 Rue Sadi Carnot - CS 00001 59790 RONCHIN - France**

La presente dichiarazione di conformità è rilasciata sotto la responsabilità esclusiva del fabbricante|Niniejsza deklaracja zgodności wydana zostaje na wyłączną odpowiedzialność producenta.|Η παρούσα δήλωση συμμόρφωσης εκδίδεται με αποκλειστική ευθύνη του κατασκευαστή|Declarația de conformitate este emisă pe răspunderea exclusivă a producătorului

**Objeto de la declaración|Przedmiot deklaracji|Στόχος της δήλωσης|Obiectul declarației|**

Tipologia di prodotto/Rodzaj produktu|Τύπος Προϊόντος|Tip produs|

**STERWINS GASOLINE CHAIN SAW, 40.1CC, 40CM**

Riferimento del prodotto/Referențe produsului|Αναφορά προϊόντος|Referință produs|

**840277 - EAN Code: 3276000696445  
Industrial Type Design Reference: PCS2-40.31**

Marca del prodotto/Marka produsului|Μάρκα προϊόντος|Marcă a produsului|

**STERWINS**

Codifica del numero di serie/Kodowanie numeru serijnego|Κωδικοποίηση σειριακού αριθμού|Cod de numere de serie|

**SN SSSSSS XX DDMMYY nn PPPPPP (SN: Serial No., SSSSSS : Supplier code, XX : Factory ID, DDMMYY: Production date, nn: number of version of product, PPPPPP : Incremental number)**

L'oggetto della dichiarazione di cui sopra è conforme alla pertinente normativa di armonizzazione dell'Unione|Wymieniony powyżej przedmiot niniejszej deklaracji jest zgodny z odnoszonymi wymaganiami unijnego prawodawstwa harmonizacyjnego|Ο στόχος της δήλωσης που περιγράφεται παραπάνω είναι σύμφωνος με τη σχετική ενωσιακή νομοθεσία εναρμόνωσης|Obiectul declarației descris mai sus este în conformitate cu legislația comunitară relevantă de armonizare a Uniunii|

Riferimenti alle pertinenti norme armonizzate utilizzate o alle specifiche in relazione alle quali è dichiarata la conformità|Odnosiťnia do odnošných norm harmonizovaných, ktoré zasťosovano, lub do špecifikáci, w odniesieniu do których deklarowano jest zgodność|Μνεία των σχετικών εναρμονισμένων προτύπων που χρησιμοποιούνται ή μνεία των προδιαγραφών σε σχέση με τις οποίες δηλώνεται η συμμόρφωση|Referințele standardelor armonizate relevante folosite sau referințele specificatorilor în legătură cu care se declară conformitatea|

Dove applicabile \* il nome e il numero del laboratorio notificato che ha rilasciato la certificazione e il riferimento al documento|W stosownych przypadkach \* należy podać nazwa i numer laboratorium, które wydało certyfikat oraz odniesienie do dokumentu|Όπου ισχύει \* το γινωστοποιημένο όνομα και τον αριθμό του εργαστηρίου που εξέδωσε την πιστοποίηση και την αναφορά στο έγγραφο|Unde este cazul \* numele și numărul de laborator notificat care a eliberat certificarea și trimiterea la document|

**2006\_42\_EC\_MACHINE  
macchine|maszyny| σχετικά με τα μηχανήματα|echipamentele tehnice|**

**EN ISO 11681-1:2011**

Verification No.: MD-295 Issue 1  
released by SGS Fimko Ltd, Takomotie 8,00380  
HELSINKI, Finland  
NB number:0598

**2014\_30\_EU EMC  
compatibilită electromagnetică|kompatybilności elektromagnetycznej|  
ηλεκτρομαγνητική συμβατότητα|compatibilitatea electromagnetical|**

**EN ISO 14982:2009**

**2011\_65\_EU\_RoHS  
Restrizione di sostanze pericolose nelle apparecchiature elettriche|Ograniczenie niebezpiecznych substancji w sprzęcie elektrycznym|Περιορισμός επικίνδυνων ουσιών σε ηλεκτρικό εξοπλισμό|Restricționarea substanțelor periculoase în echipamentele electrice|**

**(EU)2015/863 amending Directive 2011/65/EU  
IEC 62321-4:2013  
IEC 62321-5:2013  
IEC 62321-6:2015  
IEC 62321-7-1:2015  
IEC 62321-7-2:2017  
EN ISO 17075-1:2017  
IEC 62321-8:2017  
EN IEC 63000:2018**

**2000\_14\_EC\_NOISE  
'emissione acustica|emisja akustyczna|ακουστική έκδοση|emisie acustică|**

**2000/14/EC, Annex V & 2005/88/EC  
ISO 22868:2021  
EN ISO 3744:1995**

Measured sound power level:110.8dB(A),  
Guaranteed sound power level:114dB(A)

Firmato in vece e per conto di|Podpisano w imieniu|Υπογραφή για και εξ' ονόματος|Semnat pentru și în numele|

**Eric LEMOINE  
International Project Quality Leader**

Luogo e data del rilascio|Data wydania i miejsce|Τόπος και ημερομηνία έκδοσης|

**Ronchin  
29/03/2022**

**ADEO Services SAS  
135 Rue Sadi Carnot  
CS 00001  
59790 RONCHIN**





Ce produit se recycle,  
s'il n'est plus utilisable  
déposez-le en déchèterie.

Notice à trier.

Pour en savoir plus :  
[www.quefairedemesdechets.fr](http://www.quefairedemesdechets.fr)

- FR** Ce produit est recyclable. S'il ne peut plus être utilisé, veuillez l'apporter dans un centre de recyclage de déchets.
- ES** Este producto es reciclable. Si ya no se puede usar, llévelo a un centro de reciclaje de residuos.
- PT** Este produto é reciclável. Se deixar de o utilizar, entregue-o num centro de reciclagem de resíduos.
- IT** Questo prodotto può essere riciclato. Se deve essere smaltito, portalo presso un centro di riciclaggio.
- EL** Αυτό το προϊόν είναι ανακυκλώσιμο. Εάν δεν μπορεί πλέον να χρησιμοποιηθεί, μεταφέρετε την σε κάποιο κέντρο ανακύκλωσης απορριμμάτων.
- PL** Ten produkt poddawany jest recyklingowi, kiedy przestaje być użyteczny należy dostarczyć go do punktu zbiórki odpadów.
- UA** Цей продукт може перероблятися. Якщо воно більше не є придатне для використання, здайте його в утилізаційний центр.
- RO** Aceast produs este reciclabil. Dacă nu mai poate fi folosit, vă rugăm să îl aduceți într-un centru de reciclare a deșeurilor.
- EN** This product is recyclable. If it cannot be used anymore, please take it to waste recycling centre.



Made in China



\* Garantie 3 ans / 3 años de garantía / Garanzia de 3 anos / Garanzia 3 anni /  
Εγγύηση 3 ετών / Gwarancja 3-letnia / Гарантія 3 років / Garanție 3 ani /  
3-year guarantee



Adeo Services - 135, rue Sadi Carnot - CS 00001 59790 - RONCHIN-  
France

ТОВ «Леруа Мерлен Україна»,  
вул. Полярна 17а, м. Київ 04201, Україна

Imported by Adeo South Africa (PTY) LTD T/A Leroy  
Merlin Leroy Merlin Greenstone Store Corner Blackrock  
Street and Stoneridge Drive, Greenstone Park Ext 2,  
Edenvale, 1610 Johannesburg, Gauteng, South Africa