

FAR TOOLS®



REX 120C

Professional Machine

- FR** Rénovateur extérieur (Notice originale)
- EN** Exterior renovator (Original manual translation)
- DE** Schleif- und Renoviergerät (Übersetzung aus der Originalanleitung)
- ES** Fuera renovador (Traducción del manual de instrucciones original)
- IT** Restauratore di fuori (Traduzione dell'avvertenza originale)
- PT** Fora renovador (Tradução do livro de instruções original)
- NL** Buiten renovator (Vertaling van de originele instructies)
- EL** ἔξω από ανακαινιστής (Μετάφραση από τις πρωτότυπες οδηγίες)
- PL** Poza renowatora (Tłumaczenie z oryginalnej instrukcji)
- FI** Ulkopuolella remontoijille (Käännös alkuperäisestä ohjeet)
- SV** Utanför renovator (Översättning från originalinstruktioner)
- BU** Извън обновител (Превод на оригиналната инструкция)
- DA** Udenfor renovator (Oversættelse fra oprindelige brugsanvisning)
- RO** În afara renovator (Traducere din instrucțiunile originale)
- RU** Вне реставратора (Перевод с оригинальной инструкции)
- TU** Yenileyen dışında (Orijinal talimatlar çeviri)
- CS** Mimo renovátor (Příklad z originálního návodu)
- SK** Mimo renovátor (Příklad z originálneho návodu)
- HE** תוירוקמ תוארומה סוגרת) קינצופיש יוץחמ (
- AR** قتي لصلأا تاميلعتل نم قمجرتل) ح لصلم جراح (
- HU** Kívül renovator (Fordítás az eredeti utasítások)
- SL** Zunaj Obnovilac (Prevod iz izvornih navodil)
- ET** Õues renovator (Tõlge originaal juhiseid)
- LV** Ārpus atjaunotājs (Tulkojumā no instrukcijas oriģinālvalodā)
- LT** Už Restorer (Vertimas iš originalių instrukcijas)
- HR** Vanjski renovator (Izvornu obavijest)



© FAR GROUP EUROPE

115027-3-J-20210531
615228

www.fartools.com

FIG. D

01

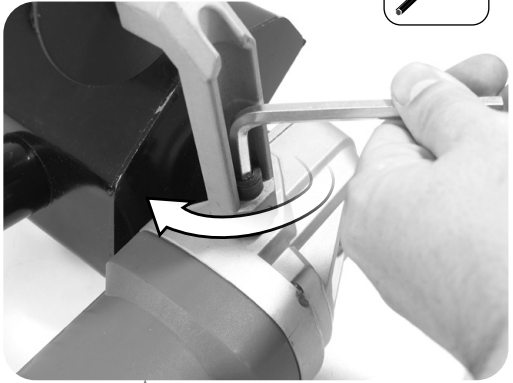
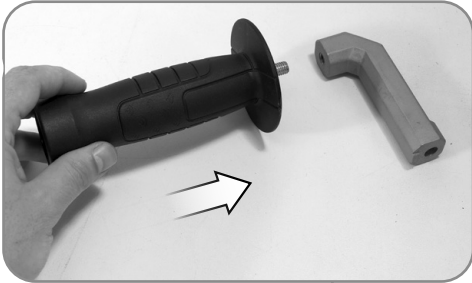

02

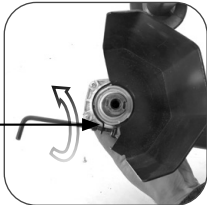
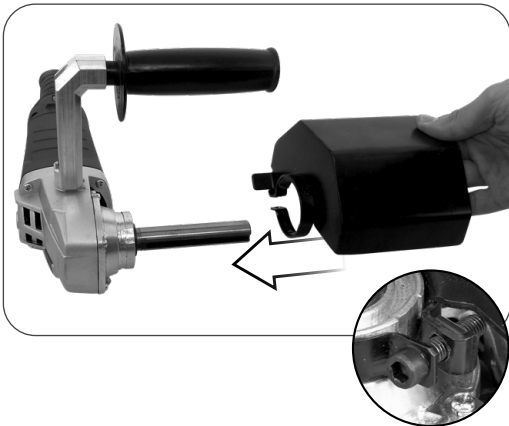

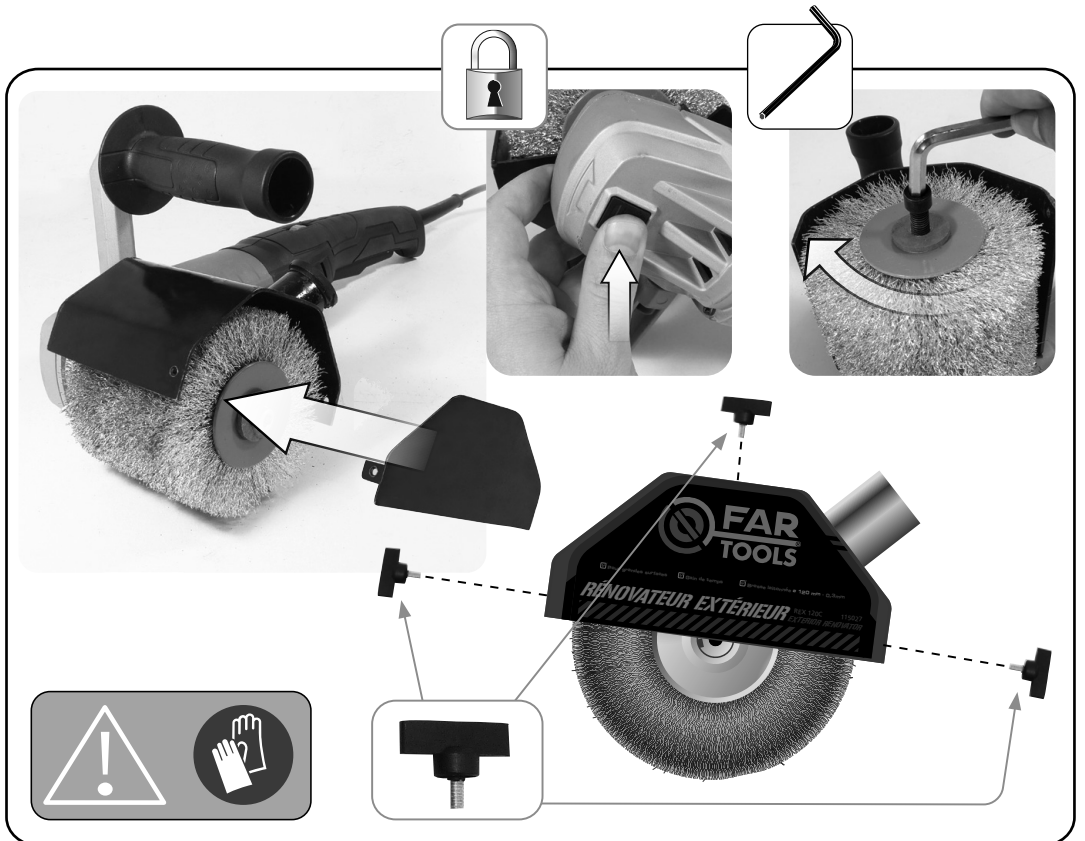
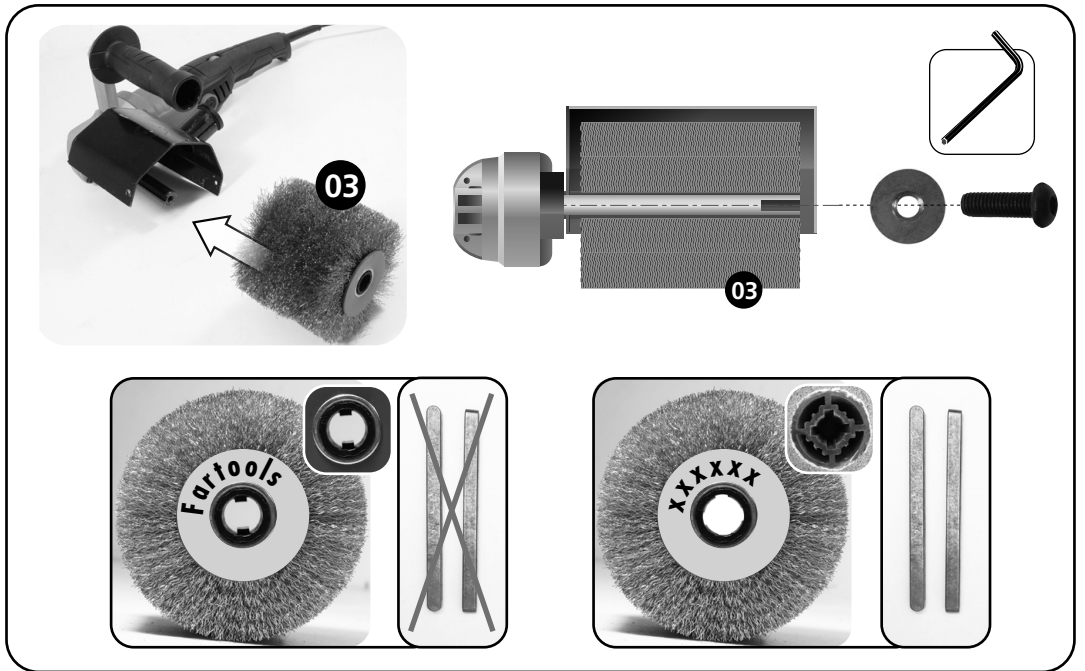

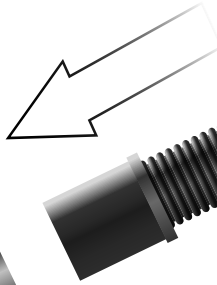
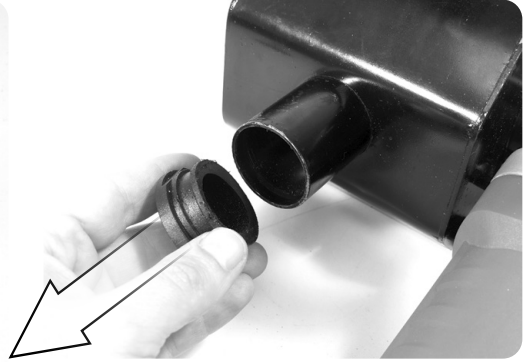

ø 35-32 mm

05

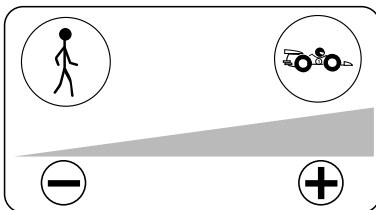

900 - 3200.min⁻¹

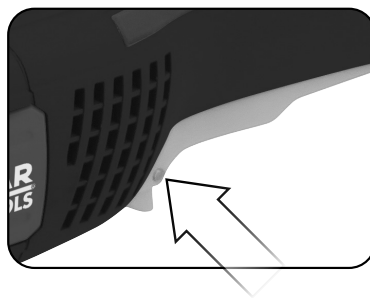
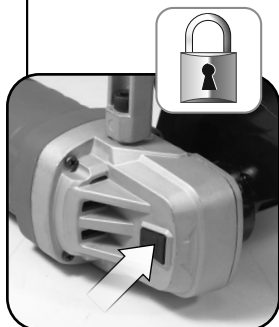
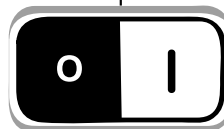

06



CONSOMMABLES

— GAMME DE BROSSES —

Consumables - Consumibles - Consumíveis



100 x ø 120 mm - Différentes broses = différents usages - REX 120 C, REX 200 & REX-H 200
Different brushes = different uses - REX 120 C, REX 200 & REX-H 200



3431541108677



Lustrer - Faire briller
Polish



3431541108738



Polir - Lustrer
Polish



3431541108899



Décrasser les joints de carrelage
Clean joints from tiles



3431541108865



Nettoyer - Décasser
Cleaning



3431541108691



Poncer surfaces incurvées
Sanding curved surfaces



3431541108684



Poncer surfaces planes
Sanding flat surfaces



3431541108851



Dégriser - Décapage léger
Deck stripper - Light stripping



3431541108745



Décapage fort
Strong stripping



3431541108882



Métal rouillé
Rusted metal



3431541108844



Meuler - Creuser
Grinding - Digging



3431541108637



Polir
Polish



3431541108640



Finition surface plane
Finishing flat surface



20 x ø 120 mm - Différentes broses = différents usages
SPECIAL REX 120 C
Different brushes = different uses
SPECIAL REX 120 C

Livré avec :
Delivered with:



3431541108974

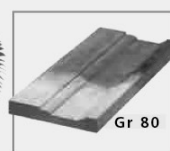

Gr 80

Poncer petites surfaces interstices
Sand down small surfaces interstices



3431541108981



Décapage fort
Stripping strong



3431541108998

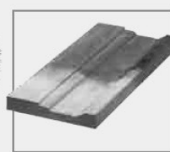





Nettoyer - Décasser
Clean - Foul up

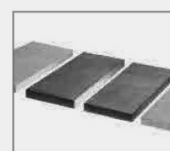



3431541108653





Nettoyer - Décasser
Clean - Foul up

	<p>Tension et fréquence assignée: Nominal frequency and power: Nennspannung und Nennfrequenz : Tensión y frecuencia fijada: Tensione e frequenza assegnata: Tensão e frequência fixa: Aangewezen spanning en frequentie: Όνομαστική τάση και συχνότητα: Napięcie i częstotliwość przydzielona: Jännite ja määrittäy taajuus: Angiven spänning och frekvens: Anført spænding og frekvens: Tensione si frequentă de lucru:</p>	<p>Заданное напряжение и частота: Tahsis gerilimi ve frekans: Stanovené napětí a frekvence: Stanovené napätie a frekvencia: מחמת ותדר מוקצב الفيلطية والذبيذبة المبرمجة Névtleges feszültség és frekvencia: Napetost in določena frekvenca: Консумирано напрежение и честота : Määratud pinge ja sagedus Nustatytą įtampa ir dažnis Noteiktais spriegums un frekvence. Napon i nazivna frekvencija:</p>	<p>230 V ~ 50 Hz</p>
	<p>Puissance assignée: Nominal power: Nennleistung: Potencia fijada: Potenza assegnata: Potência assinada: Onbelast toerental: Όνομαστική ισχύς : Prędkość na biegu jałowym: Teho: Angiven effekt: Anført styrke: Putere de lucru:</p>	<p>Заданная мощность: Tahsis edilen güç: Stanovený příkon: Predpísaný výkon: כוח מוקצב القدرة المبرمجة Névtleges teljesítmény : Določena jakost: Консумирана мощност: Määratud võimsus. Nustatytą galia Noteiktā jauda Nazivna snaga:</p>	<p>1300 W</p>
	<p>Vitesse à vide: No-load speed: Leerlaufdrehzahl: Velocidad vacía: Velocità a vuoto: Velocidade no vácuo: Leerlaufdrehzahl: Ταχύτητα στο κενό: Prędkość bezciążenia: Tyhjäkäyntinopeus Tomgångshastighet: Hastighed i ubelastet tilstand: Viteza în gol:</p>	<p>Скорость вращения на холостом ходу: Boşalma hızı: Rychlost naprázdno: Rýchlosť pri chode naprázdno: מהירות ריק السرعة على الفسارغ Üres sebesség: Prosti tek: Скорост на празни обороти: Kiirus tühikäigul Tuščio prietaiso greitis Tukšgaitas ātrums Brzina praznog hoda:</p>	<p>900 - 3200 min⁻¹</p>
	<p>Classe d'isolement : 2 Insulation class : 2 Isolierklasse: 2 Aislamiento clase :2 Isolamento classe :2 Isolamento classe :2 Isolatie Klasse : 2 Εργαλειο πέξη : 2 Izolacija Klazy :2 Eristysluokka :2 Isolering Klass :2 Isoleringsklasse 2 Clasă izolație :2</p>	<p>Класс изоляции 2 : Yalıtım derecesi :2 Třída izolace :2 Izolačný systém 2 סוג בידוד :2 فئة العزل :2 Szigetelési osztály :2 Razed izolacije :2 Инструмент Клас :2 Isolatsiooniklass 2 Izolācijas rūšis 2 Izolācijas klasē 2 Izolacija klasa: 2</p>	<p>X</p>
	<p>Diamètre de brosse et largeur : Diameter of wheel and width : Bürstendurchmesser und Breite : Cepillar diámetro y anchura: Escovar diâmetro e largura: Spennellare diámetro e larghezza: Borstel diameter en breedte: Диаметρο δίσκου : Srednica tarczy i otwór : Leikkuuterän läpimitta ja kalviminen : Skivans diameter och innerdiameter : Skivens ydre og indre diameter : Diametru disc și alezaj :</p>	<p>Диаметр диска и пропила : Disk ve delik çapı : Průměr kotouče a vrtání : Priemer kotúča a vnútorný priemer : קוטר הדיסקה וקידוד قطر الأسطوانة والتجويف A tárcsa és a furat mérete : Premer diska in izvrtine : Диаметър на резеца : Ketta ja puurimise diameeter : Skersmuo : Diska un saurplūdes atvērums diametrs : Promjer četke i širina:</p>	<p>ø 100 mm x 120 mm</p>

	Poids :	Bec :	3,5 kg
	Weight :	Ağırlık :	
	Gewicht :	Hmotnost :	
	Peso :	Hmotnost' :	
	Peso :	משקל	
	Peso :	الوزن.	
	Gewicht :	Súly :	
	Βάρος :	Teža :	
	Masa :	Тегло :	
	Paino :	Raskus	
	Vikt :	Svoris	
	Vægt :	Svars	
Greutate :	Težina:		

	Lire les instructions avant usage :	Внимательно прочитайте следующие инструкции :	X
	Read the instructions before use :	Kullanmadan talimatları okuyunuz :	
	Anleitung vor der Erstanwendung sorgfältig durchlesen :	Pozorně si přečtete následující pokyny :	
	Léase las instrucciones antes de usar :	Pred použitím si prečítajte pokyny :	
	Leggere le istruzioni prima dell'uso :	קראו היטוב	
	Ler as instruções antes da utilização :	اقرأ التعليمات قبل الاستخدام.	
	Lees voor het gebruik de instructies :	használat előtt olvassuk el az utasítást :	
	Διαβάστε τυχόν οδηγίες χρήσης :	Pred uporabo preberite ustrezna navodila :	
	Zapoznać się z instrukcją przed użyciem :	Прочетете указанията за употреба :	
	Lue ohjeet ennen käyttöä :	Enne kasutamist lugege instruksiooni	
	Läs anvisningarna före användning :	Prieš naudojimą perskaityti instrukciją	
	læs instruktionerne før brug	izlasīt instrukcijas pirms lietošanas	
Înainte de utilizare, citiți instrucțiunile :	Pročitati upute prije uporabe:		

	Conformité européenne	соответствие европейским стандартам:	X
	Conforms to EC standards :	Avrupa uygunluk :	
	CE-konform :	evropská shoda :	
	Cumple con las directivas CE :	európska dohoda :	
	Conforme alle norme CE :	התאמה לתקנים האירופיים	
	Conforme às normas CE :	مطابق للمواصفات الأوروبية.	
	Voldoet aan de EG-normen :	evropska ustreznost :	
	Συμφώνω με τα πρότυπα	európai megfeleléség :	
	Zgodność z normami CE :	Съответствие с европейските норми :	
	EU-standardien mukainen :	Euroopa Liidu vastavusmärk	
	EU-standardien mukainen :	Europinių normų atitikima	
	Overholder EU standarderne :	Atbilstība Eiropas standartiem	
Conform cu normele europene:	Evropska sukladnost		

	Danger :	Опасно :	X
	Danger :	Tehlike :	
	Gefahr :	Nebezpečí :	
	Peligro :	Nebezpečstvo :	
	Pericolo :	סכנה.	
	Perigo :	خطر.	
	Gevaar :	Veszély :	
	Κιόρνος :	Nevarnost :	
	Niebezpieczeństwo :	Опасност :	
	Vaara :	Oht	
	Fara :	Pavojus	
	Fare :	Bīstamība	
Pericol :	Opasnost:		

		M 8
---	--	-----

 L_{pA}	Niveau de pression acoustique :	Уровень акустического давления. :	88 dB (A)
	Acoustic pressure level :	Akustik basınç seviyesi :	
	Schalldruckpegel :	Hladina akustického tlaku :	
	Nivel de presión acústica :	Hladina akustického tlaku :	
	Livello di pressione acustica :	רמת לחץ אקוסטי.	
	Nivel de pressão acústica :	مستوى الضغط السمعي.	
	Niveau akoestische druk :	A hangnyomás szintje :	
	Στάθμη Θορύβου :	Nivo akustičnega pritiska:	
	Poziom mocy akustycznej :	Равнище на акустично налягане :	
	Käytä kuulosuojaimia :	Heliröhu nivoo	
Ljudtrycksnivå :	Akustinio spaudimo lygis		
Lydtryk :	Akustiskå spiediena līmenis		
Nível presiune acustică :	Razina zvučnog tlaka:		

 L_{WA}	Niveau de puissance acoustique :	уровень мощности звука :	99 dB (A)
	Acoustic power level :	Akustik basınç seviyesi :	
	Schalleistungspegel :	Hladina zvukového výkonu:	
	Nivel de potencia acústica :	Hladina zvukového výkonu:	
	Livello di potenza acustica :	רמת כוח אקוסטי.	
	Nivel de potência acústica :	مستوى الضغط السمعي.	
	Niveau akoestisch vermogen :	a hangnyomás szintje :	
	Στάθμη Ονομαστική Θορύβου :	Nivo akustične jakosti :	
	Poziom mocy akustycznej :	Равнище на вибрации :	
	Käytä suojalaseja :	Helivõimsuse nivoo	
Ljudstyrkenivå :	Triukšmo lygis		
Lydstyrke :	Akustiskās jaudas līmenis		
Nível putere acustică :	Razina zvučne snage:		

NIVEAU SONORE D'ÉMISSION :

A VIDE

Pression acoustique L_{pA} poste opérateur
Incertitude

88 dB
3

Puissance acoustique L_{WA}
Incertitude

99 dB
3

Valeurs déterminées suivant le code d'essai de l'annexe B de la norme EN 61029-1 avec emploi des normes de base ISO 11201 et ISO 3744.

Les niveaux de pression acoustique obtenus in situ dépendent:

- Des niveaux réels de la machine considérées, en prenant en compte les incertitudes déclarées;
- Du local et de l'installation de la machine. Préférez une pièce dont l'acoustique est plus feutrée. Evitez les pièces vide à grande résonance. Placez vous auprès d'une fenêtre le cas échéant.
- Des outils montés, des pièces travaillées, des réglages choisis,...

	Niveau de vibration :	Уровень вибрации :	8,85 m / s²
	Hand-Arm-Vibrationspegel :	Titreşim seviyesi :	
	Vibrationspegel Hand/Arm :	Úroveň vibrací :	
	Nivel de vibración mano/brazo :	Hladina vibrácií :	
	Livello di vibrazione mano/braccio :	רמת תנודות	
	Nível de vibração mão/braco :	مستوى الارتجاج.	
	Trillingsniveau hand/arm :	Vibrációsztint :	
	Στάθμη κρα"οασµών :	Nivo vibracij :	
	Poziom vibracji rżka/ramiż :	Равнище :	
	Tärinätaso:	Vibrācijas līmenis.	
Vibrationsnivå hand/arm :	Vibrācijas lygis		
Vibrationsniveau :	Vibratsiooni nivo		
Nível vibrații :	Razina vibracije:		

VIBRATIONS:

Total des valeurs de vibration (somme vectorielle des trois directions) déterminée selon EN 60745 :

a 8,85 m/s²
Incertitude K 1,5 m/s²

L'amplitude d'oscillation peut être utilisée comme valeur de comparaison d'outils électroportatifs.

Attention : si l'outil électroportatif est utilisé pour d'autres applications, avec d'autres outils de travail, l'amplitude d'oscillation peut être différente.

	Porter des lunettes de sécurité : Wear protective eyewear : Schutzbrille tragen : Llevar puestas gafas protectoras : Portare de gli occhiali di sicurezza : Utilizar óculos de segurança : Draag een veiligheidsbril : Φορέστε Προστατευτικά γυαλιά : Zakładać okulary ochronne : Käytä suojalasja : Använd skyddsglasögon : Der skal benyttes sikkerhedsbriller : Purtati ochelari de protectie :	Наденьте защитные очки : Güvenlik gözlükleri takın : Používejte bezpečnostní brýle : Noste ochranné okuliare : נחיתוב יפקשמ ביכרהל מן חמל נפארק וקאי. Viseljen védőszemüveget : Nositi zaščitna očala : Да се използват защитни очила : Kandke kaitseprille Nešioti apsauginius akinius Valkät aizsargbrilles Nositi zaštitne naočale:	X
---	--	--	---

	Porter un masque anti-poussière : Wear a dust mask : Staubschutzmaske tragen : Llevar puesta una careta de protección contra el polvo : Indossare una mascherina anti-polvere : Utilizar uma máscara anti-poeira : Draag een stofmasker : χρήση προστατευτική μάσκα : Zakładać maskę przeciwpyłową Käytä pölysuojust : Bär mask mot damm : Der skal benyttes beskyttelsesmaske mod støv: Purtati mască anti-praf :	Наденьте респиратор : Toza karşı maske takın : Používejte masku proti prachu : Noste ochrannú masku proti prachu : ليس قناع مضارص للغبيار. Viseljen porvédő maszkot Nositi zaščitno masko proti prahu: Да се използва защитна маска : Kandke tolmumaski. Dëvëti respiratoriuj Valkät aizsarg masku pret putekļiem Nositi masku za zaštitu od prašine:	X
---	--	--	---

	Porter une protection auditive : Wear hearing protective equipment: Gehörschutz tragen: Llevar puesta una protección auditiva: Portare una protezione uditiva: Utilizar uma protecção auditiva: Draag gehoorbeschermers: Φορέστε Προστατευτικά ακουστικά Zakładać słuchawki ochronne Käytä kuulosuojaimia: Bär hörselskydd: Der skal benyttes høreværn: Purtati căști de protectie auz:	наденьте средства звуковой защиты: İşitsel koruma aleti takın: Používejte ochranu sluchu: Noste ochranné slúchadlá: יש ל הרכיב הגנת שמיעה ليس خوذة خضض الضرجي ج Viseljen fülvédőt Nositi zašitno ušes: Да се използва слухови защитни средства: Kandke kõrvakaitset Nešioti apsaugą nuo triukšmo Valkät dzirdes aizsarglīdzekli Nositi štítņike protiv buke:	X
---	---	--	---

	Porter des gants : Use rubber gloves : Schutzhandschuhe tragen : Llevar guantes de protección : Indossare i guanti di protezione : Utilizar luvas de protecção : Draag veiligheidshandschoenen : χρήση προστατευτικών γαντιών : Używać rękawic ochronnych : Käytä suojakäsineitä : Använd skyddshandskar : Der skal benyttes handsker : Purtati mănuși :	Наденьте перчатки : Eldiven takın : Noste rukavice : Noste rukavice : תופכ שובבל מן ليس قفازات. Viseljen kesztyű t Nositi rokavice: a se използват предпазни ръкавици : Kandke kindaid Müvëti pirštines Valkät cimduš Nositi zaštitne rukavice:	X
---	--	---	---

	<p>Soumis à recyclage Subjected to recycling Sujeto a reciclaje Sottoposti a riciclaggio Sujeitos à reciclagem Nāo deite no lixo : Niet wegwerpen : Μην την πετάτε : Nie wyrzucas : Älä heittä pois luontoon : Batteriet får inte kastas : Bortkast det ikke: Nu le auncati :</p>	<p>Не выбрасывайте в мусорный ящик Atmayiniz : Nevyhazujte je do bežného odpadu : Neodhadzovat : אין לזרוק סוללות فلا ترمهه لذلك فسي القمامة. ne mečíte! Ne odvrzíte ga/jih vstran : Не го изхвърляйте : Ärge visake seda minema : Nemetykíte : Nemest : Podvrgnuto recikliranju</p>	X
---	---	--	---

Recyclage des déchets :

Les outils, accessoires et leur emballages doivent suivre une voie de recyclage adaptée. Conformément aux directives Européenne 2012/19/UE et 2006/66/CE, les composants d'un produit doivent être séparés, collectés, recyclés ou éliminés en conformité avec les réglementations environnementales en vigueur. Les appareils, batteries, piles, huiles, emballages devront être déposés dans les systèmes d'élimination des déchets spéciaux tels que déchetteries. Renseignez-vous auprès de votre commune pour connaître l'organisme le plus proche à même de traiter ou de collecter ces déchets.

	<p>Recyclable, soumis au tri sélectif Recyclable, subject to recycling Recyclingfähige, unterliegen Recycling Reciclables, sujetos a reciclaje Riciclabili, soggetti a riciclaggio Recicláveis, sujeito à reciclagem Recycleerbare, onderworpen aan recycling Ανακυκλώσιμες συσκευασίες που υπόκεινται σε κύκλωση Opakowanie nadaje się do recyklingu podlegają recyklingu Kierrätettävien pakkausten kohteena kierrätys Återvinningsbara förpackningar omfattas återvinning Рециклиращи се опаковки подлежат на рециклиране Genanvendelig underlagt genbrug</p>	<p>Reciclabile sub rezerva reciclaré Повторно упаковка подлежит вторичной переработке Gerí dönüřüm Gerí dönüřtürülebilir ambalaj konusu Recyklovateľné podléhajúci recyklácii Recyklovateľné podliehajúce recykláciiu רוחמל רווחמל הזיראה אשונ ريوئدلا ها نال يرضجت ريوئدلا ها نال نالباؤلا فويل غئلا و توبى غئلا Újrahasznosítható csomagolás alá újrahasznosítás Reciklirati predmet recikliranja Pakendite suhtes ringlussevõtu Pärstrådåjams iepakojums otrreizējai pārstrādei Perdirbamų taikomos perdirbimo Može se reciklirati, podložno selektivnom sortiranju</p>	X
---	--	---	---

REX 120C

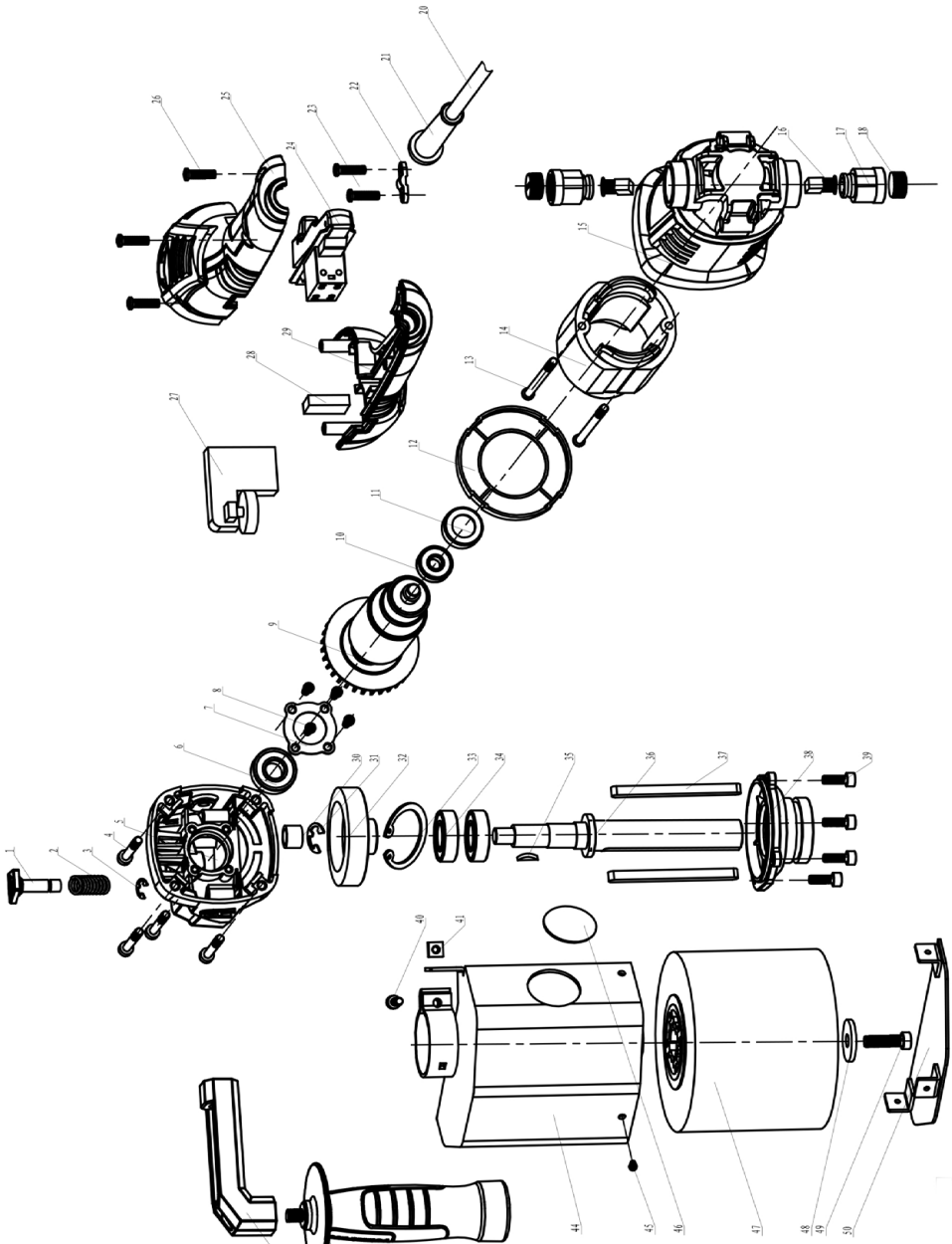

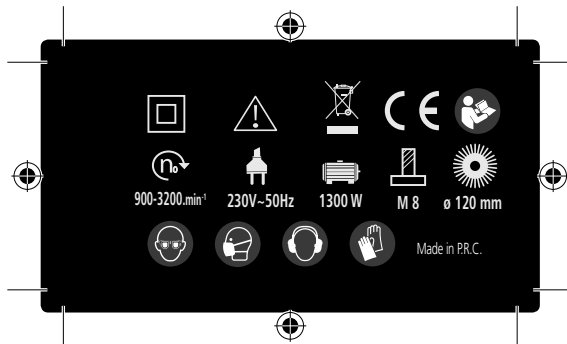

DECLARATION DE CONFORMITE
VERKLARING VAN OVEREENSTEMMING
DECLARACION DE CONFORMIDAD
DICHIARAZIONE DI CONFORMITA
KONFORMITÄTSEKLRÄRUNG
DECLARATION CONFORMITY
DECLARAÇÃO DE CONFORMIDADE
DEKLARACJA ZGODNOSCI Z NORMAMI
OM ÖVERENSSTÄMMELE
VAATIMUSTENMUKAISUUSVAKUUTUS
Overensstemmelseserklæring

Δήλωση συμμόρφωσης συμμόρφωσης

Declaratie de conformitate
Vyhlasenie zhody
Декларация соответствия
הצהרת תואמת
UYGUNLUK BEYANI
التصريح بالامتثال
Prohlášení shody
Egyezőségi nyilatkozat
Декларация за съответствие с нормите
Izjava o skladnosti
DEKLARACIA
ATTIKTIES DEKLARACIA
KINNITUS
IZJAVA O SUKLADNOSTI

Le soussigné,
Ondergetekende,
Der Unterzeichner,
O abaixo assinado,
Undertecknad,
Долгоподписаният
Undertegnede
Subsemmatut,
Я, нижеподписавшийся,
Imzalayan,
Níže podepsaný,
Toliau pasirašęs

Déclare par la présente que,
Verklaart hiermede dat,
Erklärt hiermit daß,
Declara pela presente que,
Förklarar härmed att
Заявляя с настоящего
erklærer hermed, at
Declar prin prezenta că,
настоящим подтверждаю, что
Mevcut belgeyle beyan ediliyor ki,
tímto prohlašuje, že,
Pareiškia, kad,

Personne autorisée à constituer
le dossier technique :
Christophe HUREL



FAR GROUP EUROPE
192, Avenue Yves Farge
37700 St. Pierre-des-Corps
FRANCE

El suscrito,
Il sottoscritto,
The undersigned,
Nínej podpisany
Allekirjoittanut,
Ουπτογεγραμμένος
Nižšie podpisany
החתום מטעם
الموقع أدناه
Alulírott,
Podpisani,
Apakšā parakstījis
allakirjutanu
Dolje potpisani,

Declare por la presente, que,
Dichiare che,
Declares that,
Oświadczam niniejszym, że
Ilmoittetaan täten että,
Δηλώνω με την Παράστα
tymto vyhlasuje, že
מצהיר בזה כי
يصرح إسئنادا على ذلك
kijelenem, hogy a készülék Izjavlja da,
Pareiškia, kad,
Ar šlo aplicina, ka,
Kinnitab, et
Izjavljuje u ovom dokumentu da je

Rénovateur extérieur / Exterior renovator / Schleif- und Renoviergerät / Fuera renovador / Restauratore di fuori / Fora renovador / Buiten renovator /
Έξω από ανακαινιστής / Poza renovatora / Ulkopuolella remonttijille / Utanför renovator / Извън обновения / Udenfor renovator / In afara renovator /
Bue restaarapora / Yenileen dışında / Mimo renovátor / Mimo renovátor / קונצופיש וחורח / كرنجفوش و حورح / Kivül renovator / Zunaj Obnovilac / Öues renovator /
árpus atjaunotājs / UZ Restorer / Vanjski renovator

code

FARTOOLS / 115027 / REX 120C / R7401

Est conforme et satisfait aux directives et normes CE,
In overeenstemming is met en Voldoet aan EG richtlijnen,
Mit folgenden EU-Richtlinien und -Normen übereinstimmt,
Respeita e está em conformidade com as normas CE,
Överensstämmer med och uppfyller EG-standarder,
Съответства и отговаря европейските норми
er i overensstemmelse med og overholder EU standarderne
Este conform și satisface normele CE
полностью соответствует и удовлетворяет
требованиям стандартов ЕС
CE şartlara uygundur,
odpovídá normám ES,
Atitinka ir atitinka EB direktyvas ir standartus,

Cumple con la directivas de la CE,
E conforme alle direttive CEE,
Complies with the EEC directives and standards,
Odpowiada normom UE,
Täyttää EU-vaatimukset,
Είμαι σύμφωνα και ανταποκρίνεται στα Πρότυπα CE
zodpovedá normám ES,
מתאים ועונה לתקני CE
بان الیواز یطابق و یلسی مع الیوز مجموعة الدول الأورویی
kielégíti a CE szabványok előírásait.
Je v skladu z in izpolnjuje norme Evropske skupnosti.
Atbilst un atbilst EK direktīvas un standartus,
Vastab ja vastab EU direktīvidele ja standartidele,
Sukladan i ispunjava direktive i standarde CE,

2006/42/EC 2014/30/EU 2011/65/EU 2015/863/EU
EN62841-1:2015+AC:15
EN62841-2-4:2014+AC:15
EN55014-1:2017
EN55014-2:2015
EN61000-3-2:2014
EN61000-3-3:2013

Christophe HUREL,
Président Directeur Général
20/08/2020

Fait à St. Pierre-des-Corps

FR. GARANTIE

Cet outil est garanti contractuellement contre tout vice de construction et de matière, à compter de la date de vente à l'utilisateur et sur simple présentation du ticket de caisse. La garantie consiste à remplacer les parties défectueuses. Cette garantie n'est pas applicable en cas d'exploitation non conforme aux normes de l'appareil, ni en cas de dommages causés par des interventions non autorisées ou par négligence de la part de l'acheteur. La garantie ne s'applique pas sur les dommages causés par une défaillance de l'outil.

DE. GARANTIE

Dieses Produkt ist durch eine Herstellergarantie vertraglich abgedeckt. Die Garantie deckt ab Kaufdatum und bei Vorlage des Kassensbons alle Mängel ab, die auf Material- oder Herstellungsfehlern beruhen. Sie besteht darin, fehlerhafte Teile zu ersetzen. Von der Garantie sind ausgenommen: Schäden durch unsachgemäßen Gebrauch, durch unsachgemäße Eingriffe oder durch Fahrlässigkeit des Nutzers. Die Garantie erstreckt sich nicht auf Schäden, die auf Ausfall des Geräts zurückzuführen sind.

IT. GARANZIA

Quest' attrezzo è garantito per contratto contro qualsiasi difetto di costruzione e di materia, a partire dalla data di vendita all' utente e su semplice presentazione dello scontrino. La garanzia consiste nel sostituire le parti difettose. Questa garanzia non è applicabile in caso di sfruttamento non conforme alle norme dell' apparecchio, né in caso di danni causati da interventi non autorizzati o da negligenza da parte dell' acquirente. La garanzia non si applica ai danni causati da un' avaria dell' attrezzo.

EN. GARANTEE

This tool is guaranteed, in writing, against any defect in manufacture or parts from the date of sale, upon simple presentation of the sales slip. The guarantee is limited to the replacement of faulty parts. This guarantee is not applicable in the event of usage which is not conform with the intended usage of the apparatus, nor in the event of damage caused by unauthorised servicing or negligence on behalf of the purchaser. This guarantee does not apply to any damage caused by the failure of this tool.

ES. GARANTIA

Esta herramienta se garantiza contractualmente contra todo defecto de construcción y materia, a partir de la fecha de venta a l' usuario y sobre simple presentación del recibo de caja. La garantía consiste en sustituir a las partes defectuosas. Esta garantía no es aplicable en caso de explotación no conforme a las normas del aparato, ni en caso de daños causados por intervenciones no autorizadas o por negligencia por parte del comprador. La garantía no se aplica sobre los daños causados por un fallo del herramienta.

NL. GARANTIE

Dit gereedschap heeft een garantie tegen constructiefouten en materiaaldefecten, die geldig is vanaf de aankoopdatum door de gebruiker, op vertoning van de kassabon. De garantie betreft de vervanging van de defecte onderdelen. Deze garantie is niet van toepassing indien het apparaat niet volgens de normen gebruikt is, noch in geval van schade veroorzaakt door oneigenlijk gebruik of nalatigheid van de koper. De garantie is niet van toepassing op schade voortvloeiend uit een defect van het gereedschap.

PT. GARANTIA

Esta ferramenta tem uma garantia contratual contra qualquer defeito de construção e de material, a partir da data de venda ao utilizador e sobre simples apresentação do talão da caixa. A garantia consiste em substituir as partes defeituosas. Esta garantia não é aplicável no caso de exploração não conforme às normas do aparelho, nem em caso de danos causados pelas intervenções não autorizadas ou por negligência da parte do comprador. A garantia não se aplica para os danos causados por uma falha da ferramenta.

EL. Εγγύηση

Το εργαλείο αυτό φέρει συμβατική εγγύηση για οποιόδήποτε ελάττωμα κατασκευής απ'ο την ημερομηνία Π'ωλησης στο χρώστη. με ΑΠ'ή Προσκόμιση της απ'ο "οειξηής αγοράς. Η εγγύηση αποτελείται απ'ο την αντικατάσταση των ελαττωματικών τμημάτων. Η Παρούσα εγγύηση δεν εφαρμόζεται σε περίπτωση χρήσης μη σύμφωνα με τα Πρότυπα της συσκευής. η σε περίπτωση ζημιών που Προκλήθηκε απ'ο μη εγκατεστημένη ή απ'ο αμέλεια του αγοραστή. Η εγγύηση δεν εφαρμόζεται στις ζημιές που Προκαλούνται απ'ο βλάβη του εργαλείου Σταυρού κενού Διαστήμω-Παρέμβυσμα

PL. GWARANCJA

Narz'dzie jest obj'ete gwarancją na wszelkie wady konstrukcyjne i materiałowe, licząc od daty sprzedaży u'ytkownikowi i po okazaniu paragonu kasowego. Gwarancją obejmuje wymian' cz'Ąci wybrakowanych. Gwarancją nie znajduje zastosowania w przypadku u'ytkowania niezgodnego z normami urz'adzenia, ani w przypadku szkód spowodowanych działaniami niedozwolonymi lub zaniedbaniami ze strony nabywcy. Gwarancją nie obejmuje szkód powstałych z powodu upadku urz'adzenia.

SV. GARANTI

Detta verktyg har en avtalsenlig garanti mot konstruktions- och materialfel, från och med tidpunkten för användarens inköp och genom uppvissning av kassakvittot. Garantin består i att ersätta de bristfälliga delarna. Denna garanti gäller inte om användningen inte motsvarar apparatens standarder, inte heller vid skador som orsakas av ej tillåtna ingrepp eller på grund av köparens vårdslöshet. Garantin gäller inte förskador som orsakats av att verktyget fungerat bristfälligt.

FI. TAKUU

Tämän laitteen takuu on voimassa sopimuksenmukaisesti kattaen kaikki rakenne- ja materiaali- ja lukien ostopäivästä kassakuitista vastaan. Takuu sisältää viallisten osien korvaamisen. Takuu ei korvaa ohjeidenvastaista käyttöä eikä valtuuttamattomien henkilöiden käsittelystä tai ostajan huolimattomuudesta aiheutuneita vahinkoja. Takuu ei vastaa myöskään toimintahäiriöistä aiheutuneita vahinkoja.

BU. Гаранция

Този инструмент е под договорна гаранция срещу всякакъв дефект в изработката и използваните материали, считано от датата на продажба на потребителя и само срещу представяне на касовата бележка. Гаранционното обслужване се състои в замяна на дефектните части. Настоящата гаранция не е валидна когато апаратът се използва по начин, несъответстващ на стандарта за работа с него, както и в случай на щети, нанесени от неоторизирани лица, или вследствие на проявена небрежност от страна потребителя.

Гаранцията не покрива щети, произтекли вследствие на техническа неизправност на апарата.

