

# MALMÖ II

**5,6m<sup>2</sup>**  
**caseta** /shed/arrumação exterior<sup>1)</sup>

MANUAL  
DE INSTRUCCIONES<sup>2)</sup>

EN-1) **caseta** /shed/arrumação exterior

FR-1) **abri de jardin** caseta/shed/arrumação exterior

PT-1) **abrigo** /shed/arrumação exterior

EN-2) USER'S GUIDE

FR-2) INSTRUCTIONS DE MONTAGE

PT-2) MANUAL DE INSTRUÇÕES

# Manual de instrucciones (ESP)

- Son necesarias dos personas para el montaje de la caseta.
- El montaje puede llevar entre 2 y 4 horas.
- Ponerse en contacto con las autoridades para determinar si la instalación está autorizada.
- Se recomienda el montaje en días secos y sin viento.
- Planifique la ubicación antes del inicio del montaje.
- La caseta debe situar se en un lugar a prueba de viento y con un buen sistema de drenaje.
- Comprobar antes de comenzar el montaje que tiene todas las piezas.
- Herramientas necesarias para su montaje:

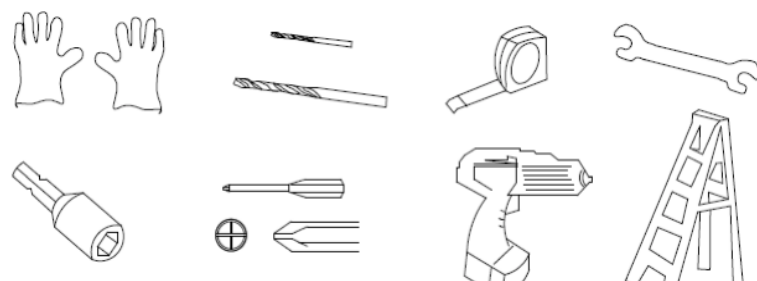

- Por favor, retire el plástico protector antes de proceder al montaje.
- Es importante seguir estas instrucciones paso a paso.
- No montar la caseta/armario cerca de niños y/o mascotas.
- La caseta se debe montar sobre una base alineada de madera o un suelo llano de cemento.
- Recomendamos retirar la nieve de la caseta metálica después de cada nevada.
- Nunca debe concentrar el peso del cuerpo en el techo.
- Se recomienda para su correcta conservación mantener limpia la caseta con un trapo suave y tener limpio el carril de la puerta para su correcto deslizamiento.
- Las casetas están destinadas únicamente a almacenar objetos se prohíbe la residencia u otros efectos.



# User 's guide

- Two people are required to assemble the shed.
- The assembly may take between 2 and 4 hours.
- Contact the authorities to determine if the installation is authorized.
- It is advisable to assemble the shed on dry and calm days.
- Plan the location before you start the assembly.
- The shed must be located in a windproof place and posses a good draining system.
- Before starting the assembly, please check that you have all the pieces.
- Necessary tools:

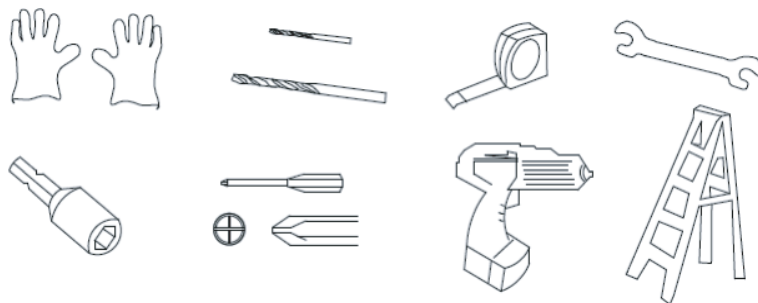

- Please remove the protector plastic before beginning the assembly.
- It is important that you follow these instructions step by step.
- Do not assemble the shed close to children and/or pets.
- The shed must be assembled on an aligned wooden base or a flat concrete floor.
- We recommend removing any snow from the metallic shed after a snowfall.
- Do not concentrate all the weight of the shed on the roof.
- For the proper conservation of the shed, clean it with a soft cloth and ensure that the rail is kept free of dirt for the door to slide properly.
- The sheds are designed for storage purposes only and may not be used to live in or for any other purposes.



# Manual de instruções

- Para a montagem do abrigo são necessárias duas pessoas
- A montagem pode demorar entre 2 a 4 horas.
- Entre em contato com as autoridades para determinar se a instalação está autorizada.
- Recomenda-se a realização da montagem em dias secos
- Antes de dar início à montagem determine onde ficará
- O abrigo deve ser montado num local à prova de vento e com um bom sistema de drenagem.
- Antes de dar início à montagem, verifique se pos sui todas as peças .
- Ferramentas necessárias para a montagem:

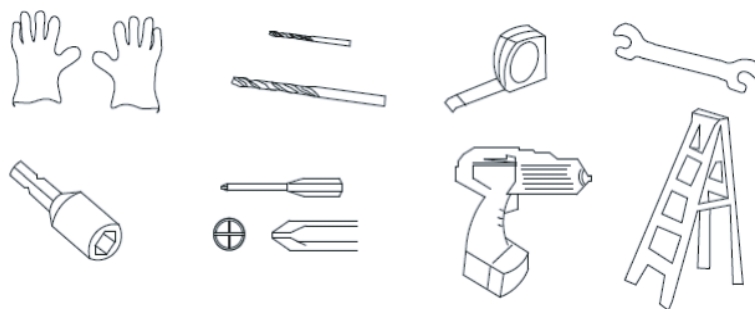

- Remova o plástico antes de proceder à montagem.
- É importante seguir as instruções passo a passo.
- Não montar o abrigo perto de crianças e/ou de animais domésticos.
- O abrigo deve ser montado sobre uma base nivelada de madeira, em solo plano, de cimento.
- Em caso de queda de neve, recomenda-se a remoção da neve do abrigo metálico.
- Nunca concentrar o peso do corpo no tecto.
- Para a correcta conservação do abrigo recomenda-se que este seja mantido limpo, utilizando um pano suave, e a limpeza regular da calha da porta para o seu correcto deslizamento.
- Os abrigos destinam-se exclusivamente ao armazenamento de objectos. É proibida a sua utilização para habitação ou para outros fins.







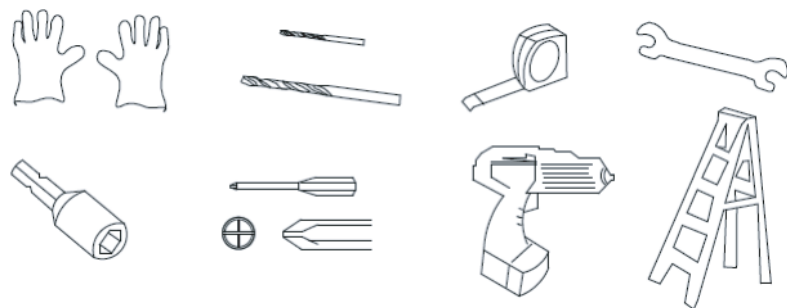



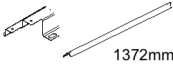

# Manual de montage





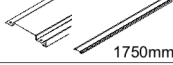

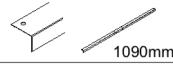
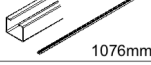
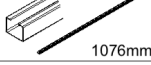
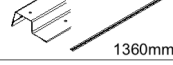
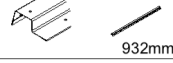
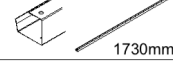
- Deux personnes sont nécessaires pour assembler l'abri.
- Le montage peut prendre entre 2 et 4 heures.
- Contactez les autorités pour déterminer si l'installation est autorisée.
- Il est recommandé de faire le montage les jours secs et sans vent.
- Planifiez l'emplacement avant de procéder au montage.
- L'abri doit se placer dans un endroit à l'épreuve du vent et avec un bon système de drainage.
- Avant de commencer le montage vérifiez toutes les pièces.
- Outils requis pour le montage:

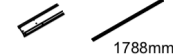

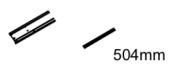
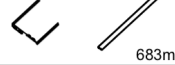

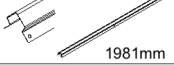

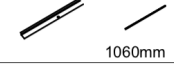
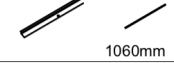
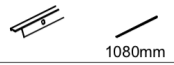
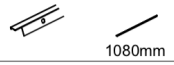
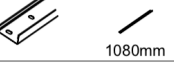
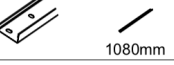
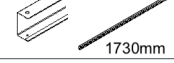
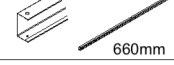
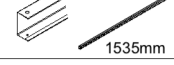

- Retirez le plastique protecteur avant le montage.
- Il est important de suivre ces instructions étape par étape.
- Ne pas monter l'abri autour des enfants et / ou des animaux.
- L'abri doit être monté sur une base alignée en bois ou sur un solplat en béton.
- Il est recommandé de déneiger l'abri en métal après chaque chute de neige.
- Ne concentrez jamais le poids du corps sur le toit.
- Il est recommandé de maintenir propre l'abri à l'aide d'un chiffon doux et maintenir propre le rail de la porte pour un glissement correcte.
- Les abris sont uniquement destinés à stocker des objets, il est interdit de les utiliser comme résidence ou d'autres fins.

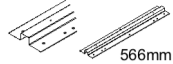
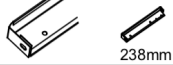
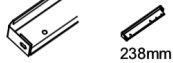
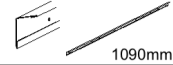

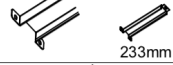
NO.	PART	Qty.
1	 1372mm	2
1-1	 944mm	3
2	 1372mm	1
3L	 692mm	1
3R	 692mm	1
4L	 1750mm	1
4R	 1750mm	1
5	 1030mm	1
6	 1090mm	1
7L	 1076mm	1
7R	 1076mm	1
9	 1360mm	1
9-1	 932mm	1
10	 1730mm	1
10-1	 660mm	1
11	 1788mm	2

NO.	PART	Qty.
11-1	 504mm	2
11-2	 683mm	1
12L	 1105mm	1
12R	 1105mm	1
13	 1981mm	2
13-1	 1750mm	2
14L	 1060mm	1
14R	 1060mm	1
15L	 1080mm	1
15R	 1080mm	1
16L	 1080mm	1
16R	 1080mm	1
17	 1730mm	1
17-1	 660mm	1
17-2	 1535mm	2
17-3	 838mm	2

NO.	PART	Qty.
18	 566mm	6
19L	 238mm	1
19R	 238mm	1
20	 1090mm	4
21L		1
21R		1
22	 233mm	2
22L		1
22R		1
B1	 90mm	2
B2	 165mm	2



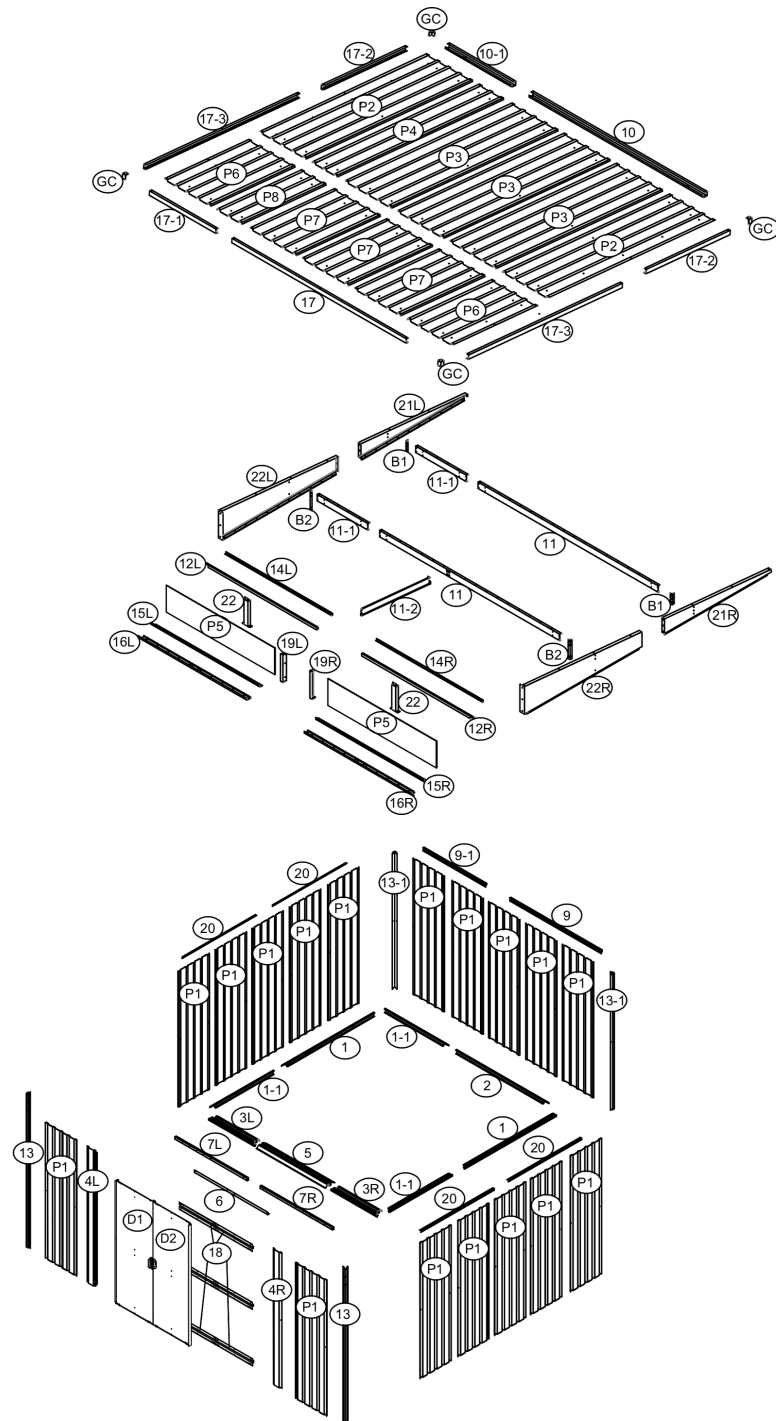

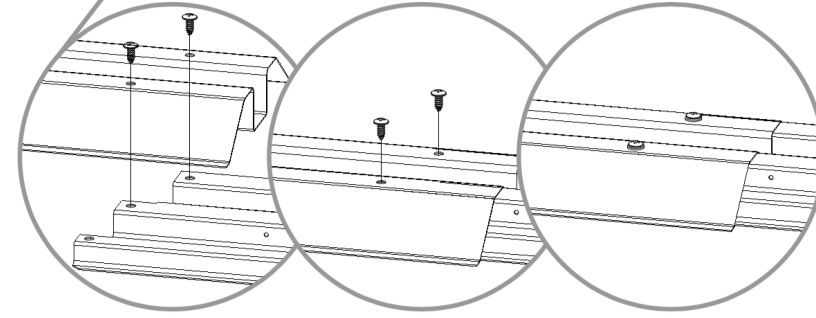
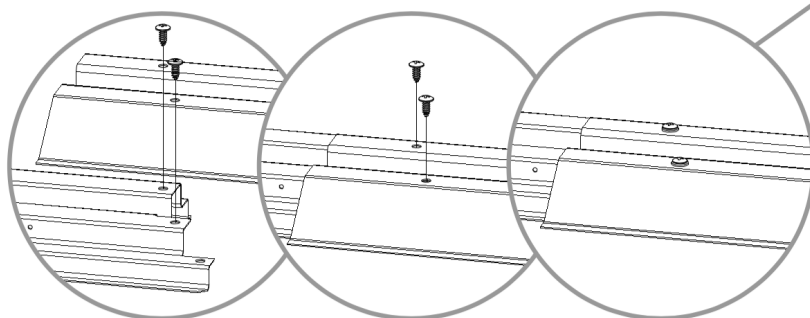
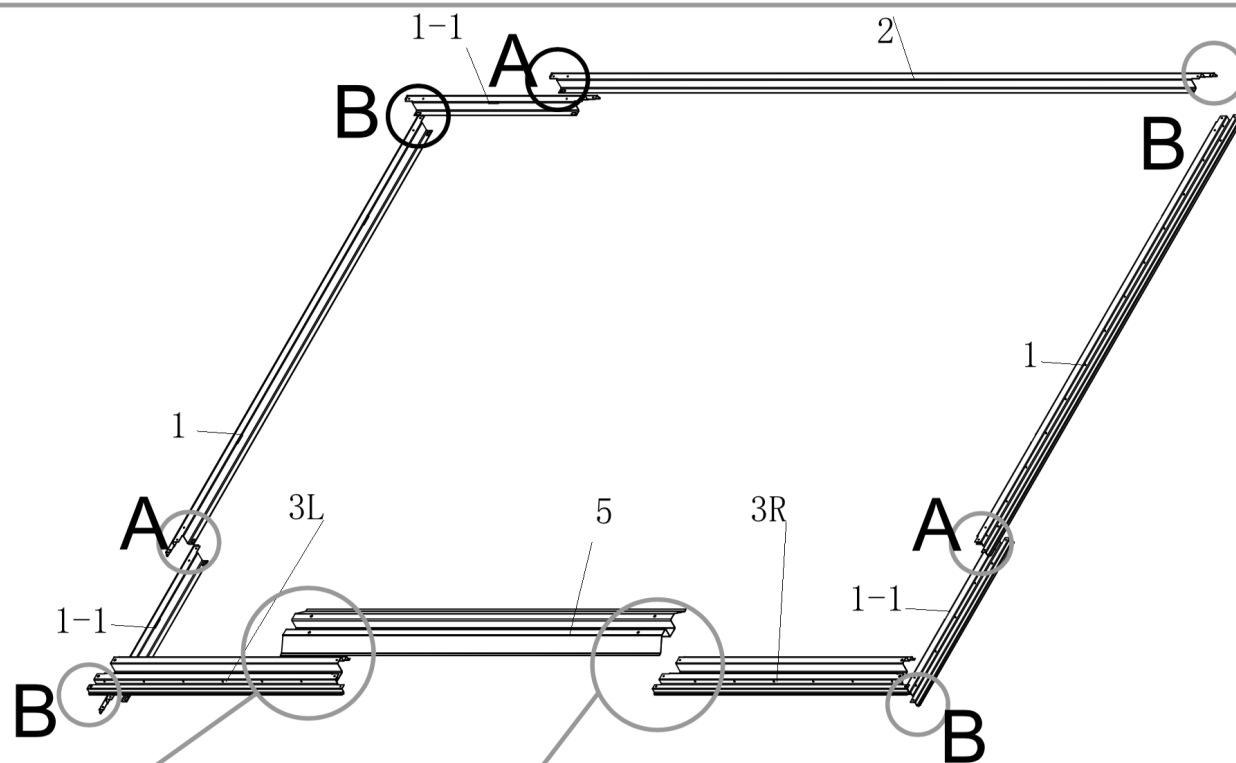
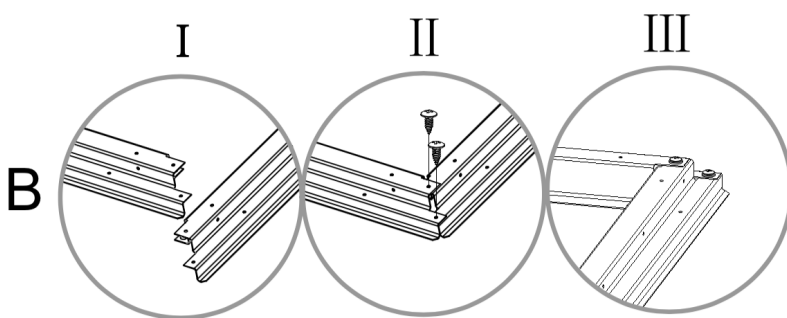
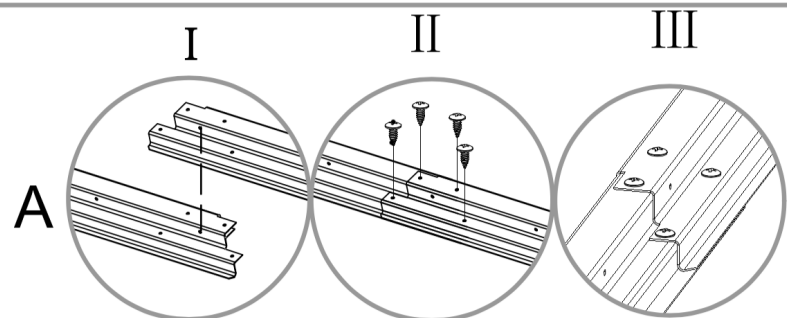
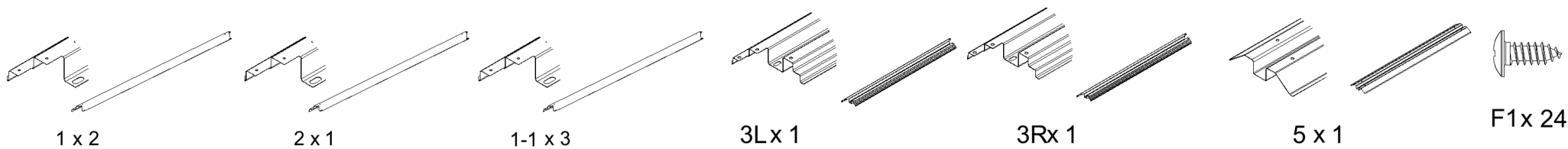

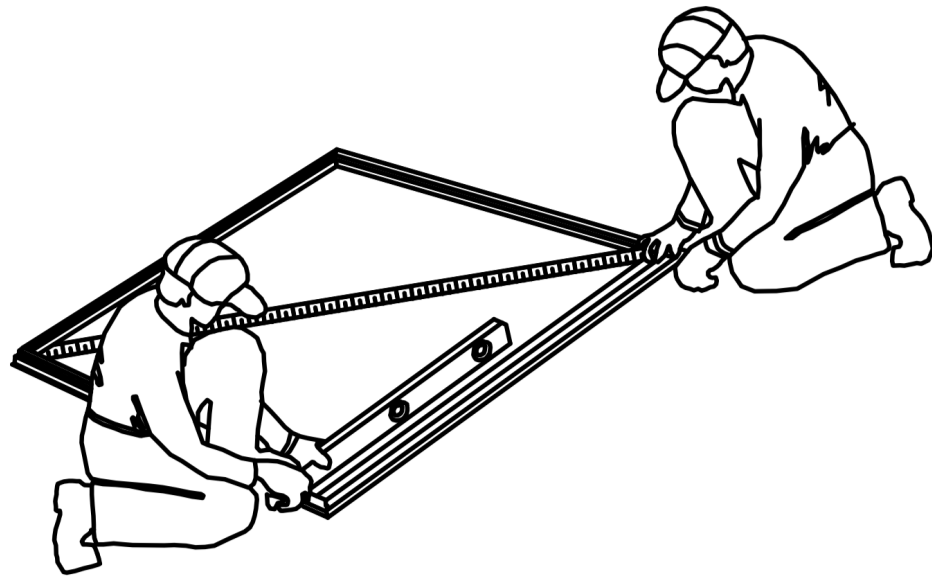
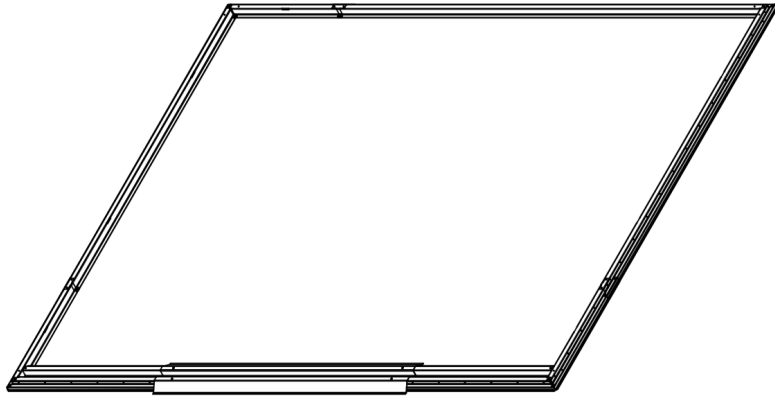

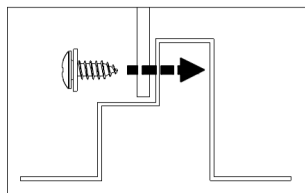
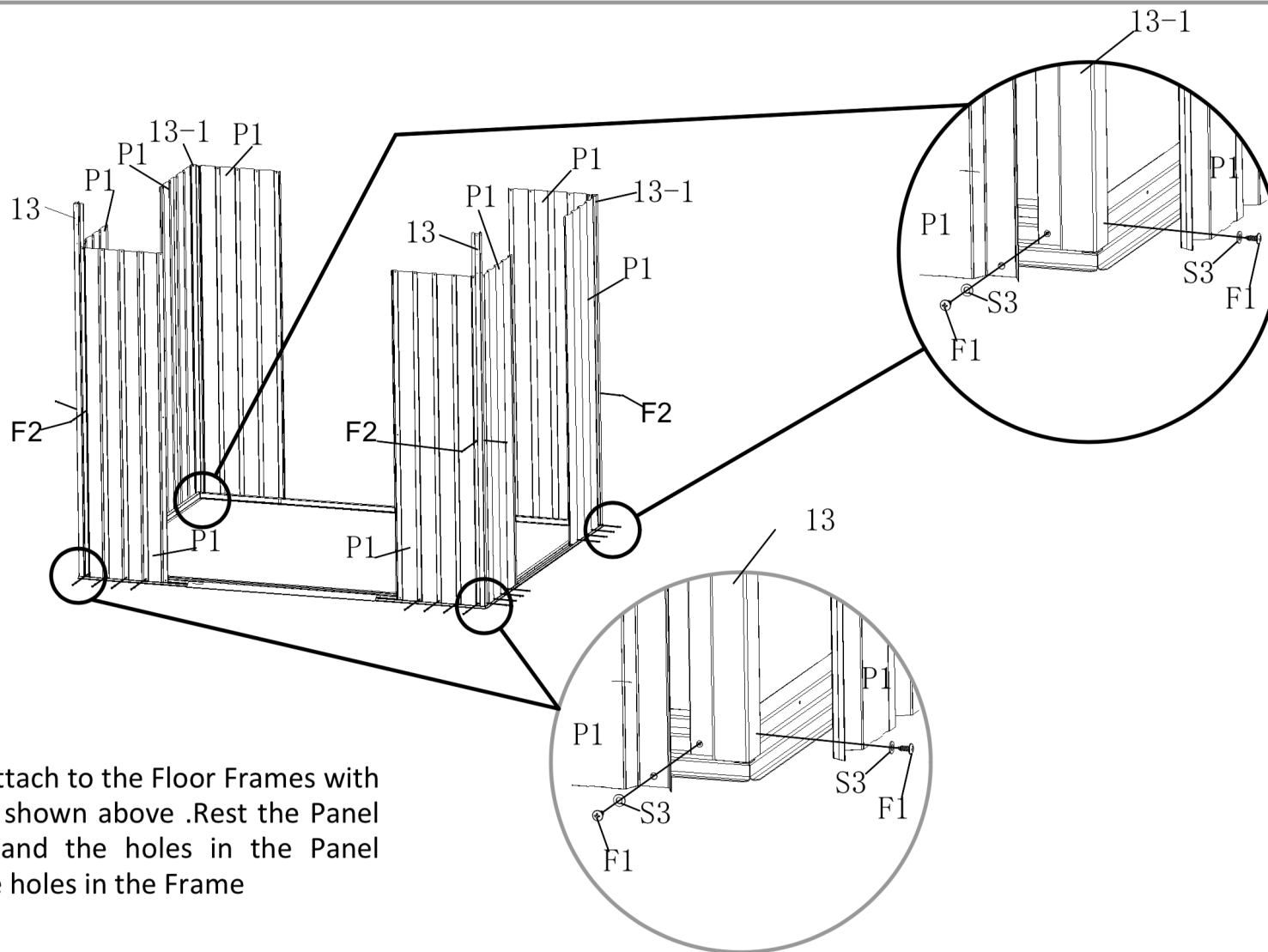
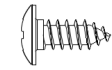
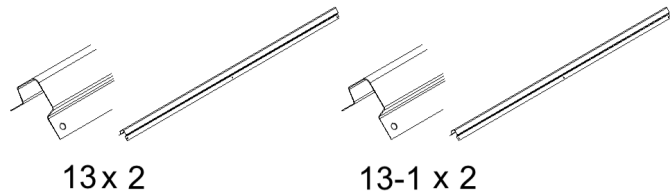
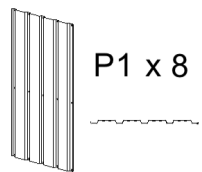

Wall panels ALWAYS attach to the Floor Frames with Screws in the manner shown above. Rest the Panel on the Floor Frame and the holes in the Panel should line up with the holes in the Frame



21L x 1

21R x 1

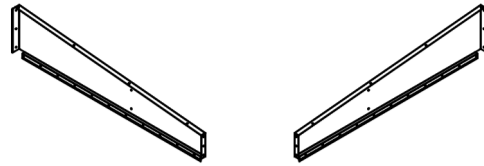

22L x 1

22Rx 1

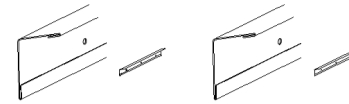

B1 x 2

B2 x 2



F2 x 18

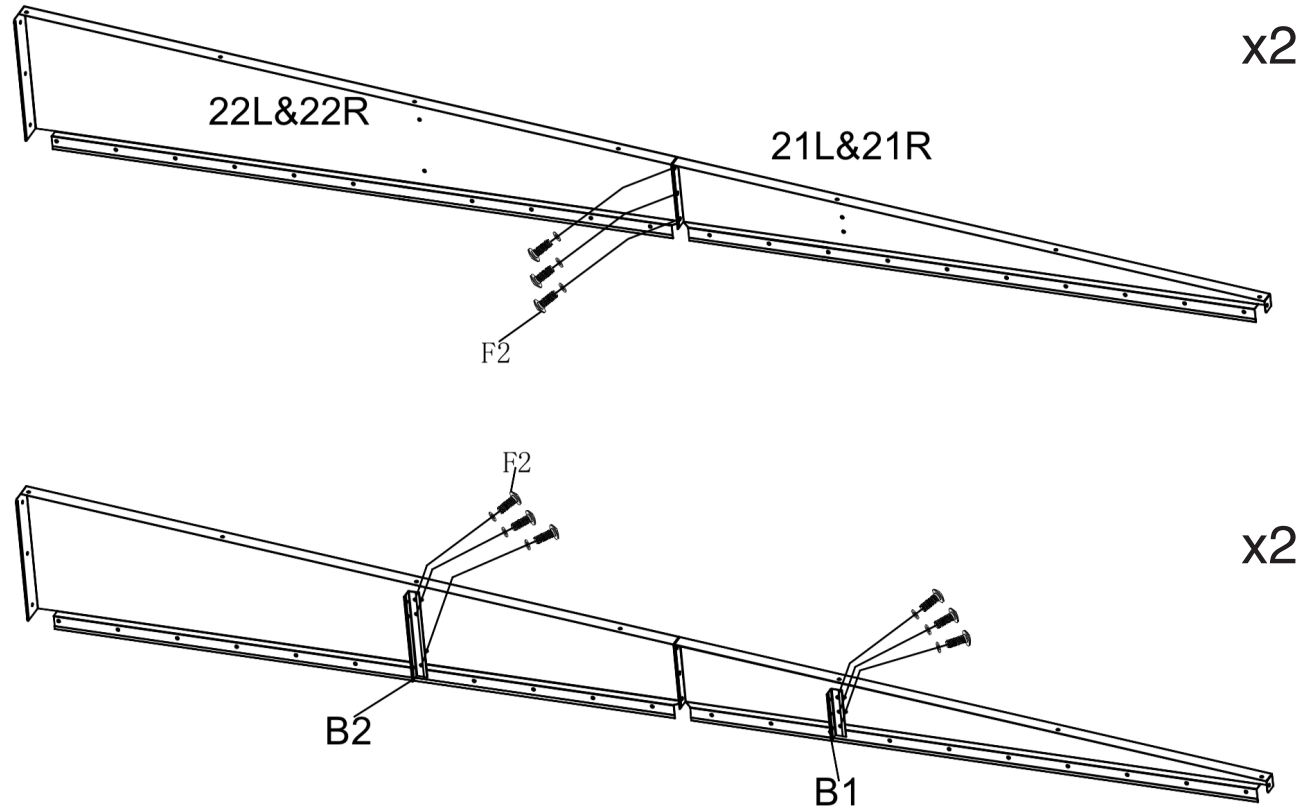

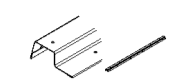

9-1x1

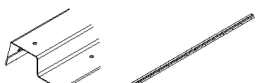

9x1



20x4

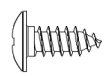

F1x28



F2x6



S3x26

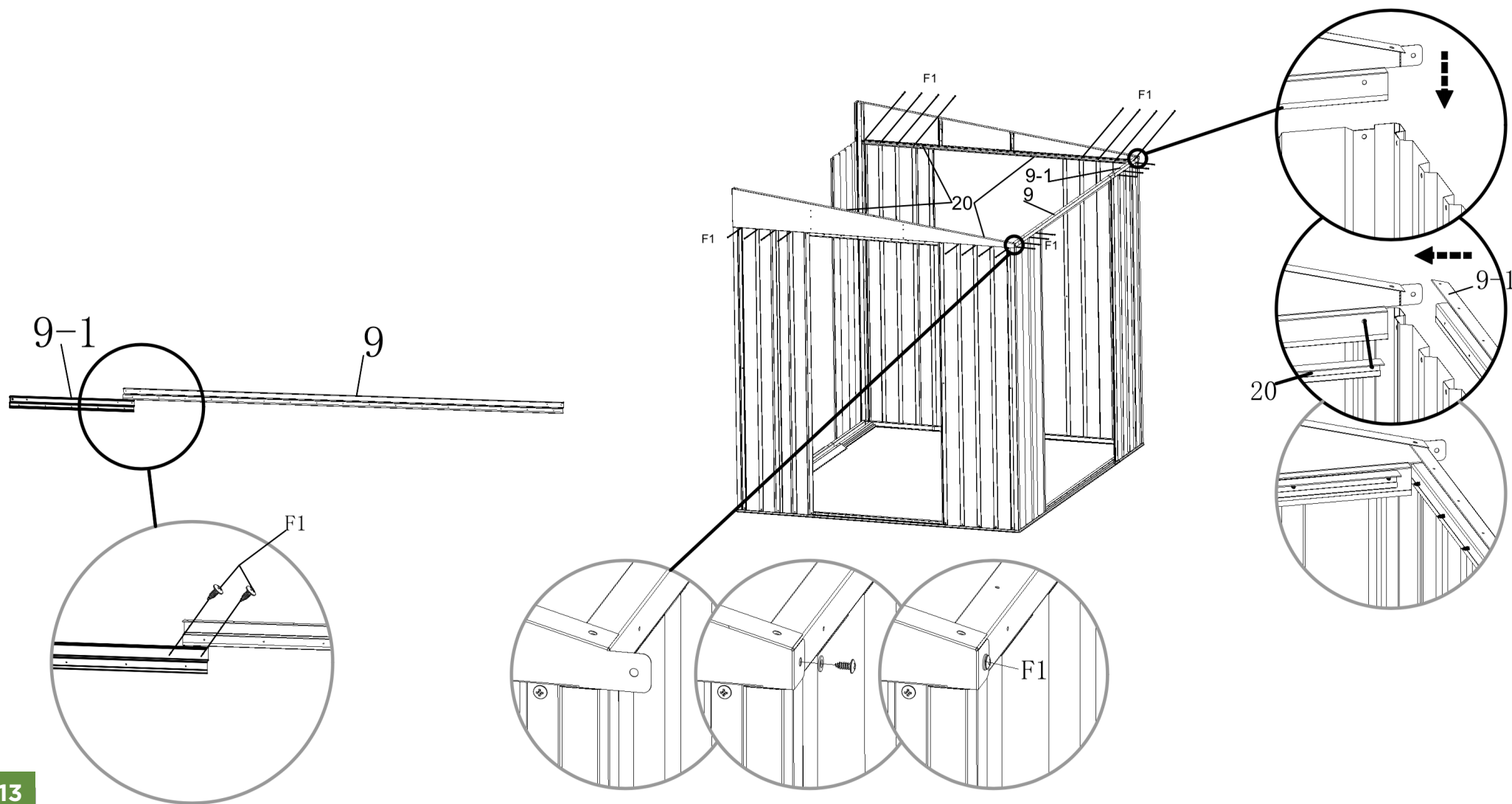

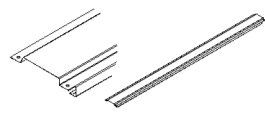

4L x 1

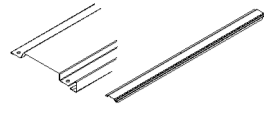

4R x 1

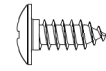

F1 x 4

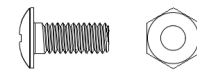

F2 x 2



S3 x 6

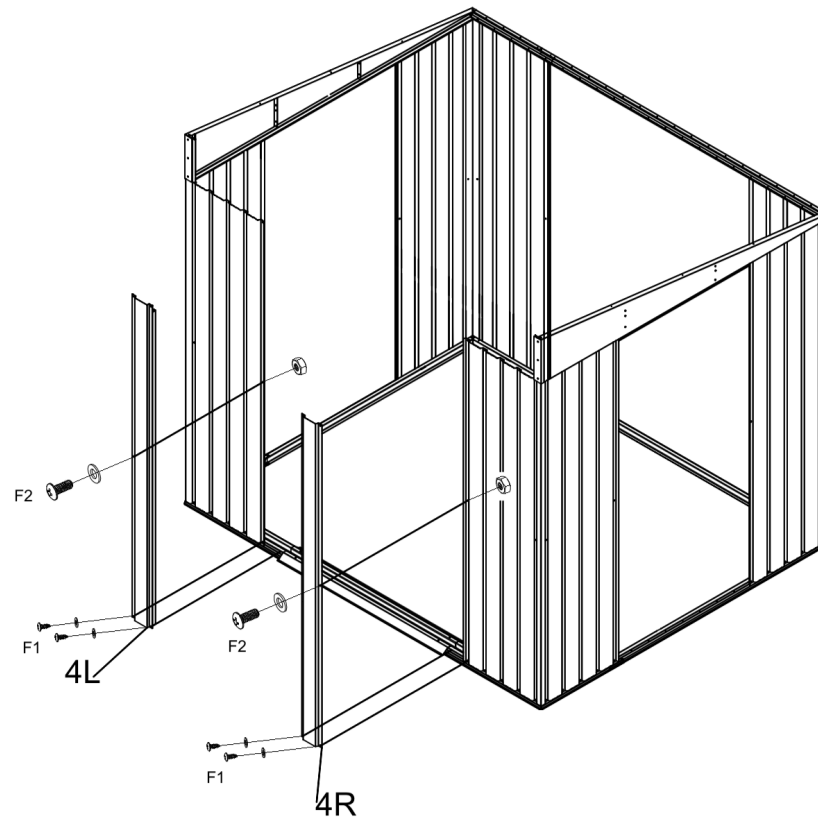

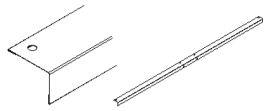

6 x 1



7Lx1



7Rx1

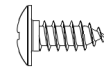

F1 x 2



S3 x 2

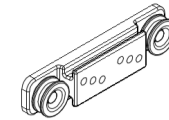

G2 x 4

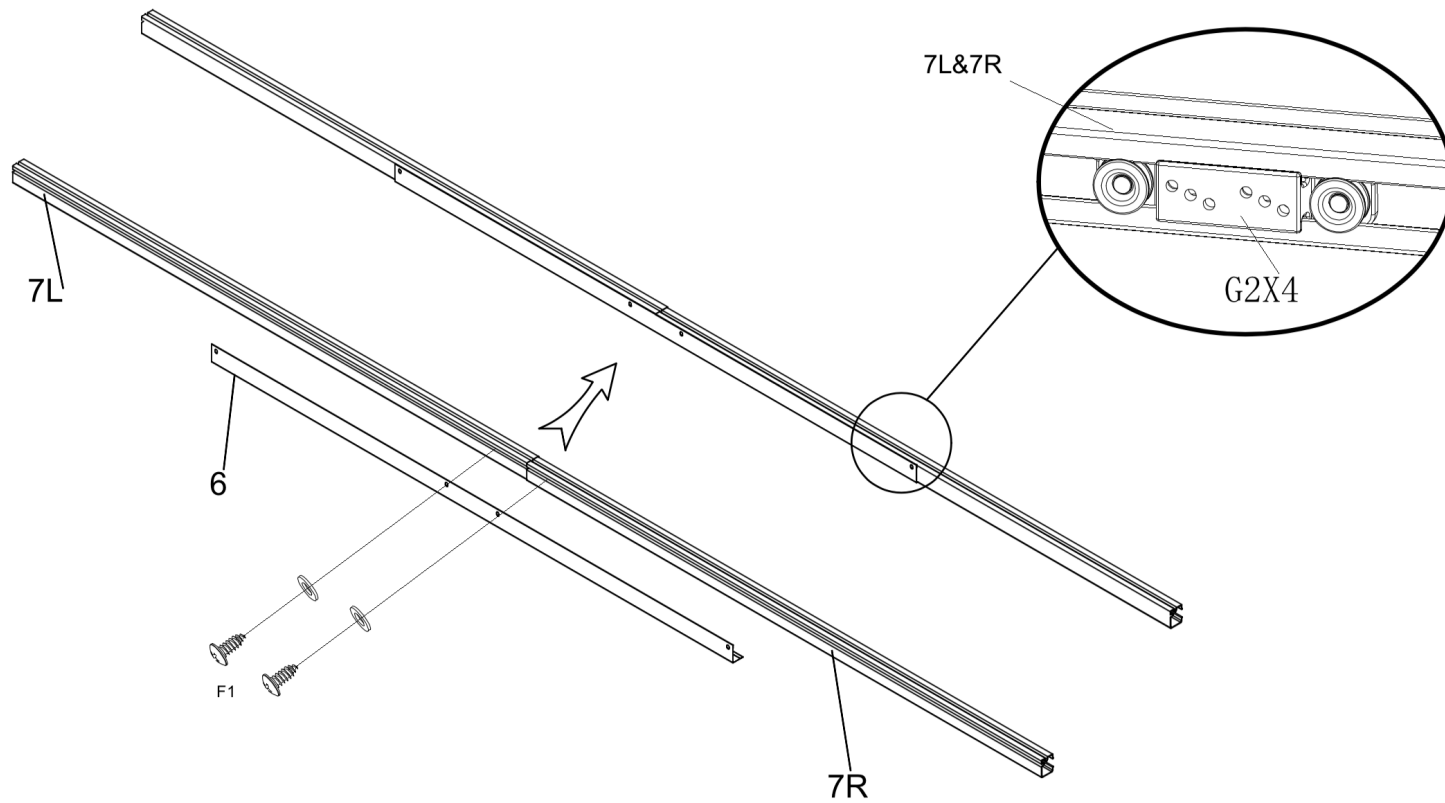

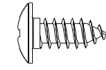

F1 x 12



S3 x 12

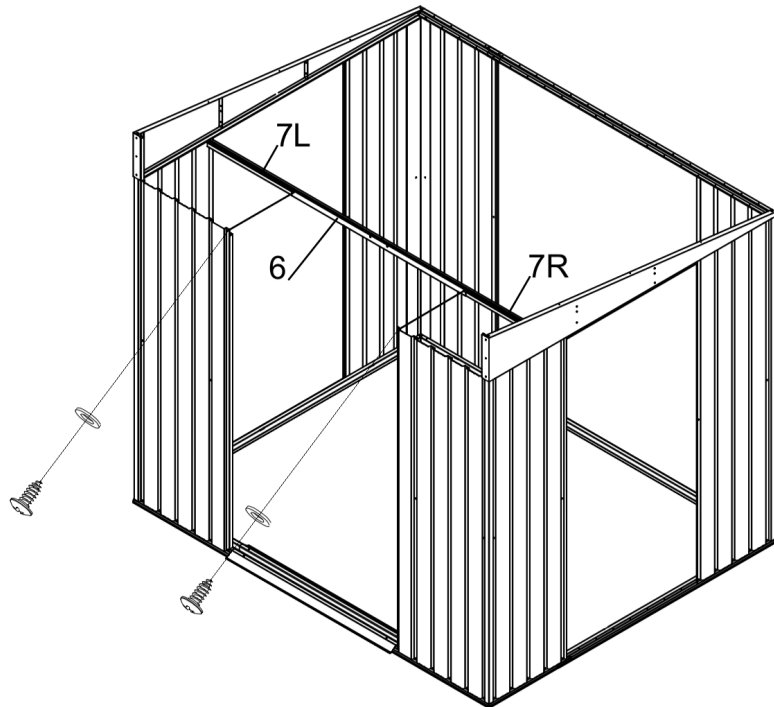

I

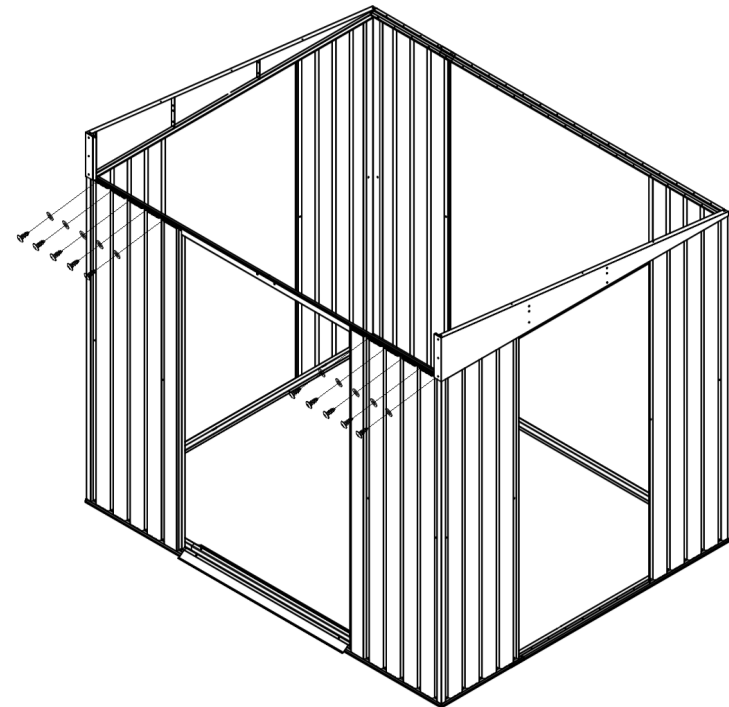

II

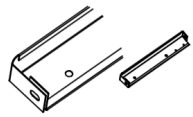

19Rx 1



15Rx 1

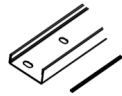

16Rx 1

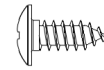

F1 x 1

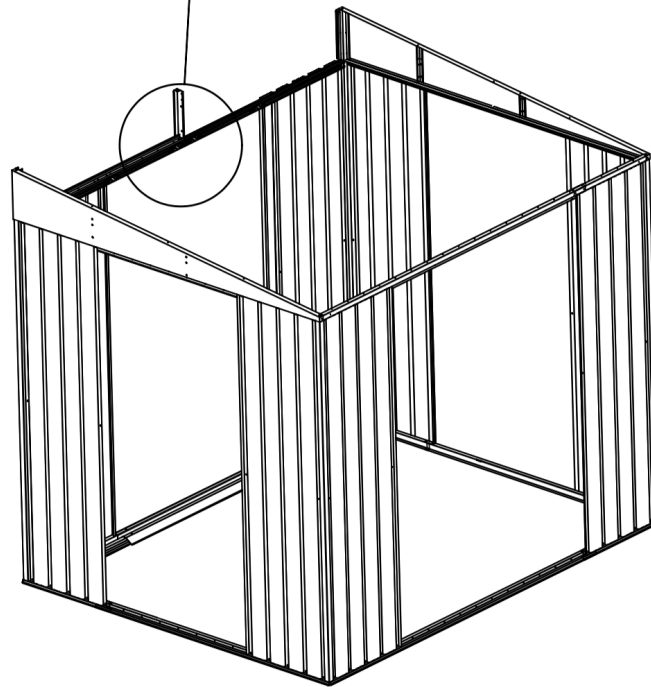
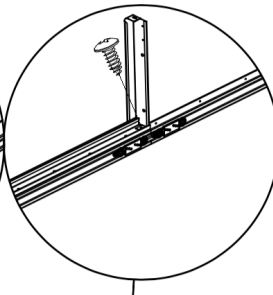
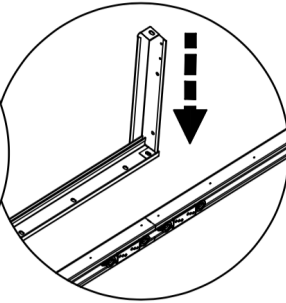
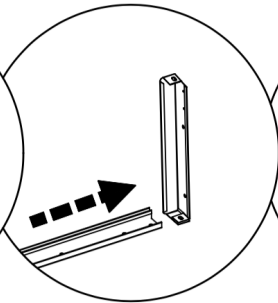
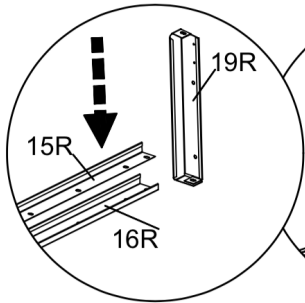

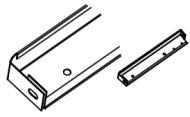

19L x 1

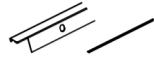

15L x 1

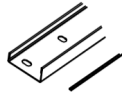

16L x 1

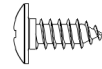

F1 x 1

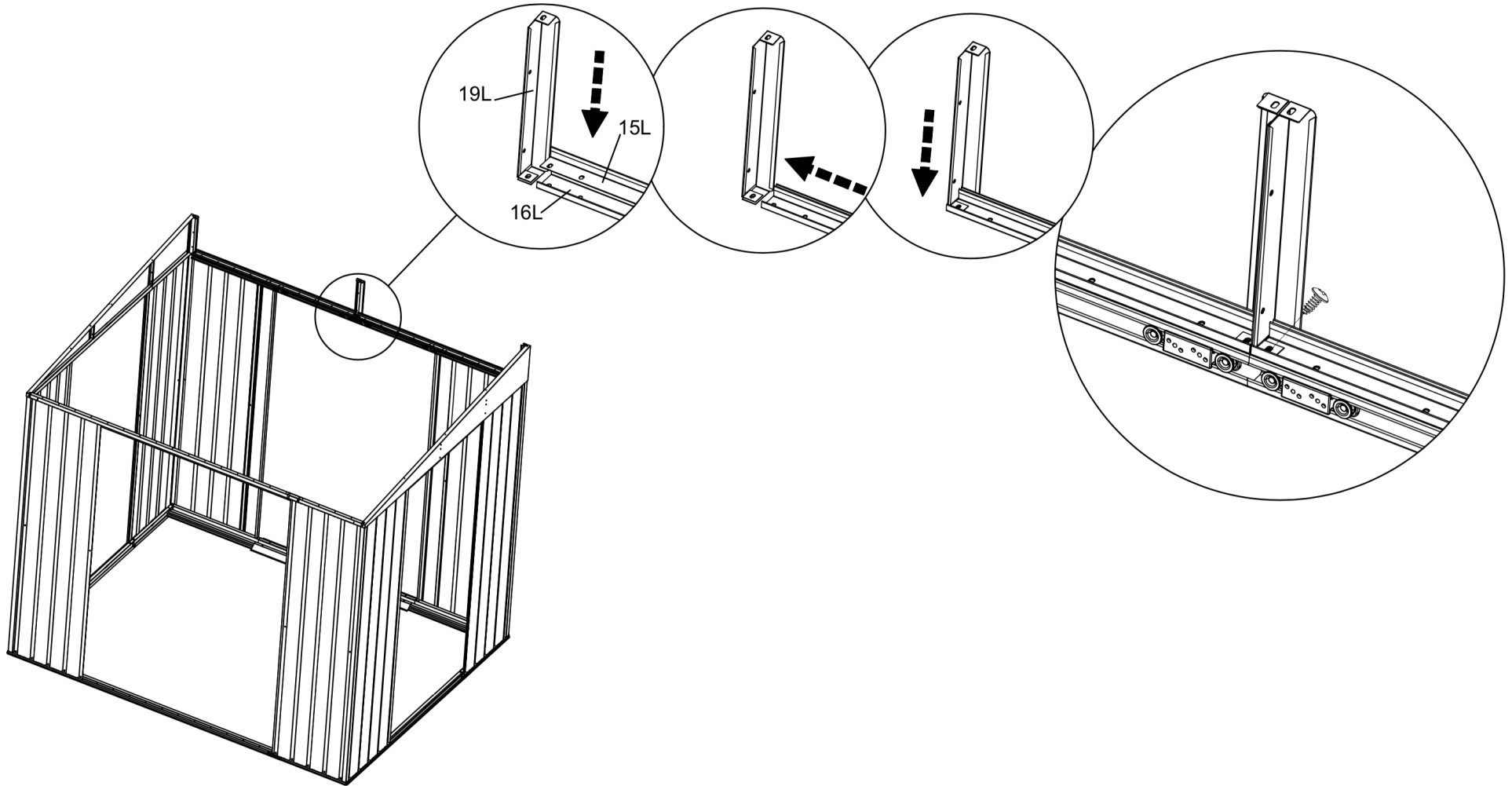



P5 x 2

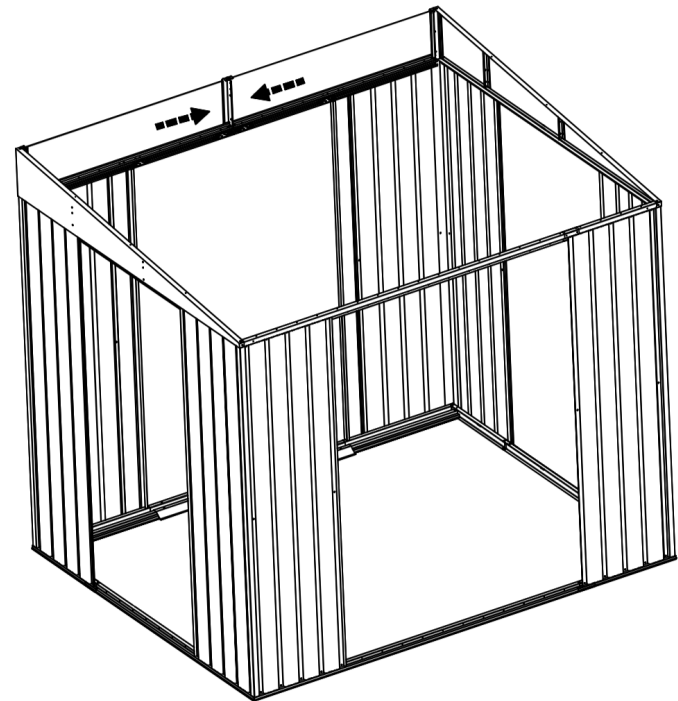
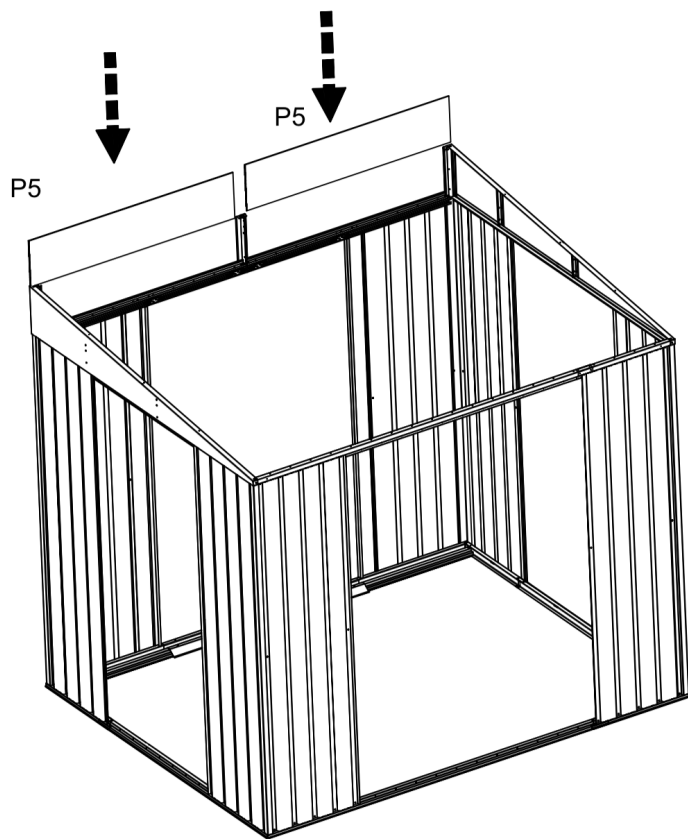

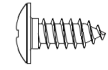

F1 x 20

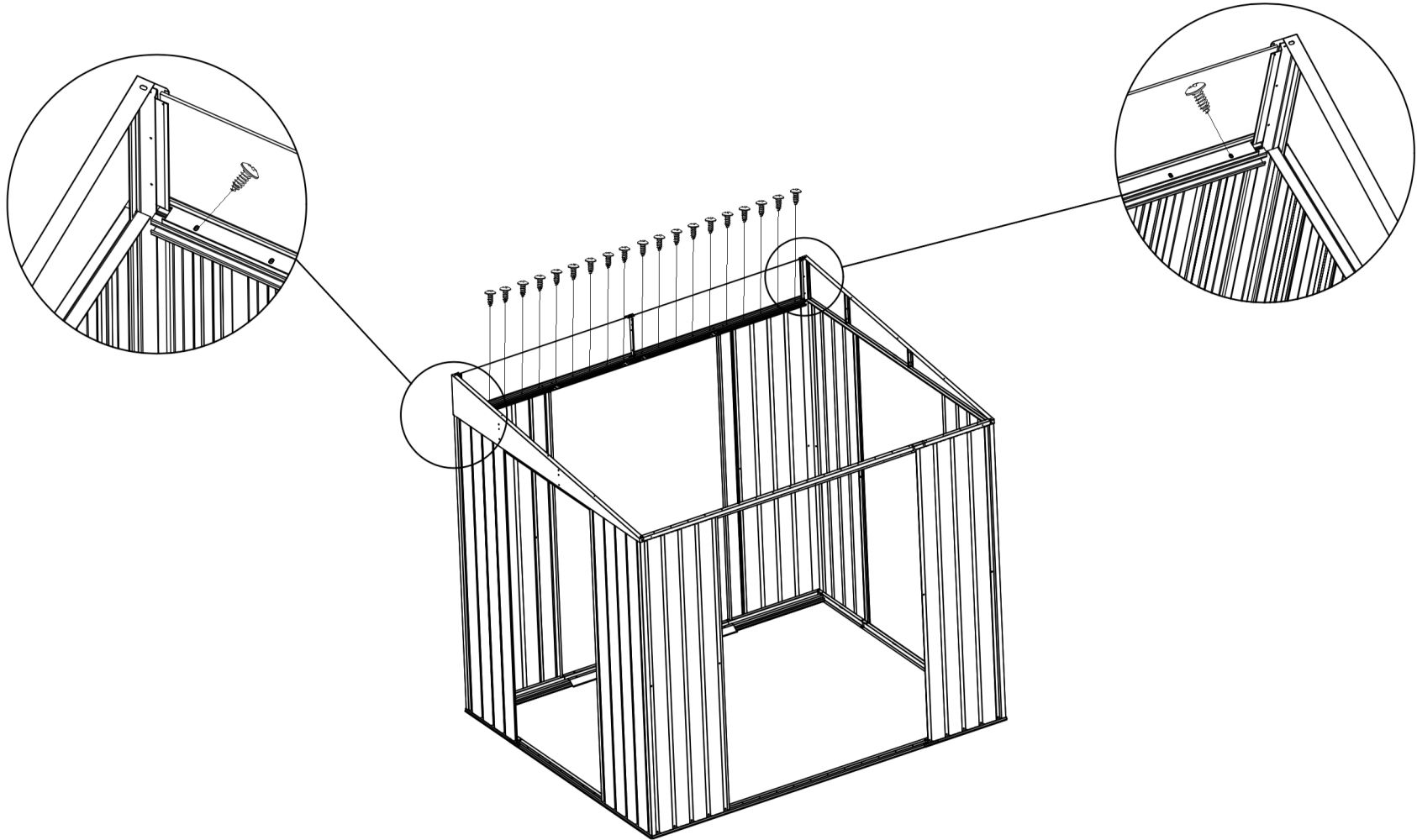

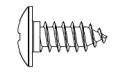
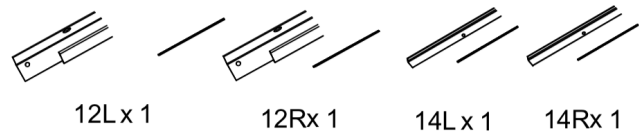

F1 x 12

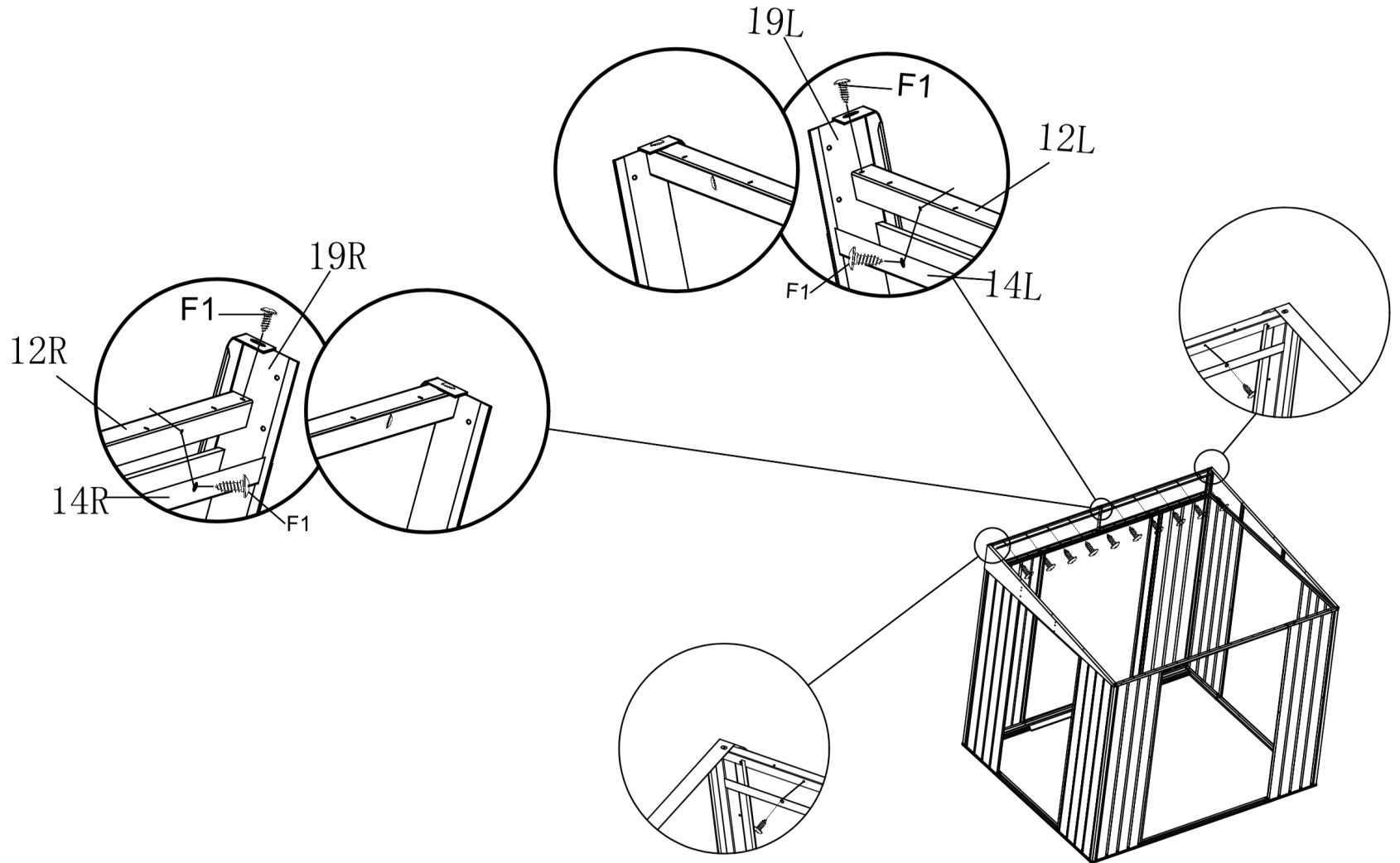

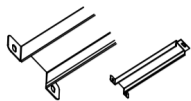

22 x 2

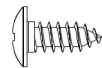

F1 x 6

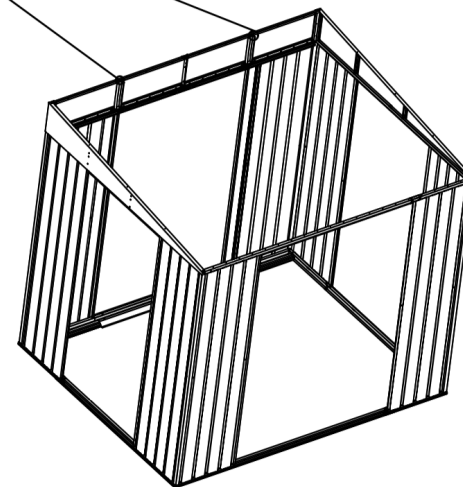
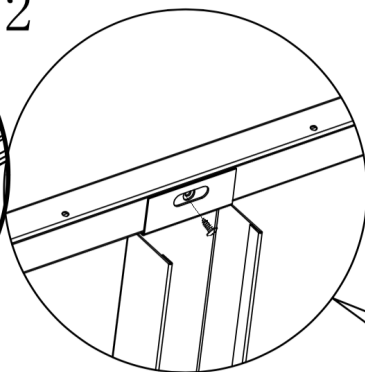
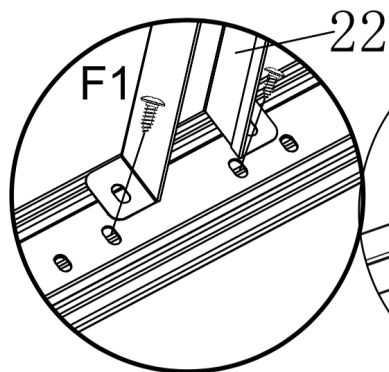

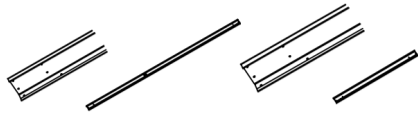

11x2

11-1 x 2

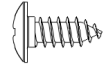

F1 x 16

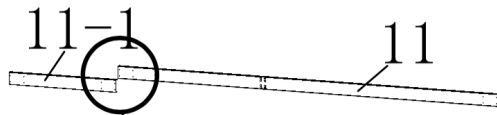
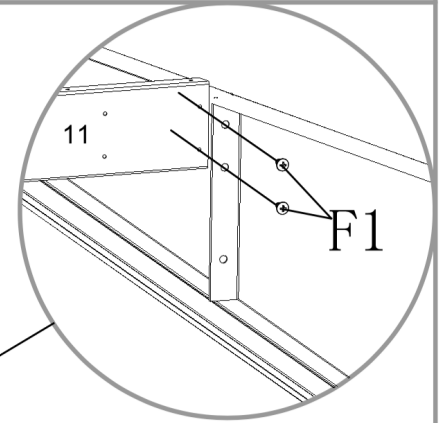
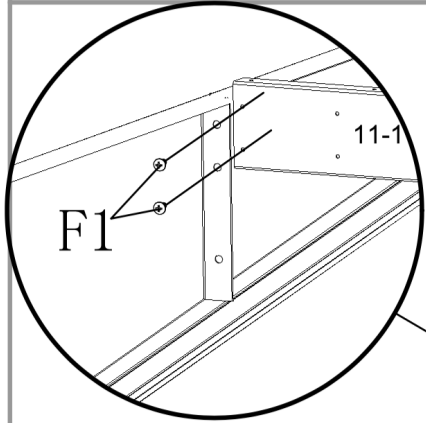

11-1

11

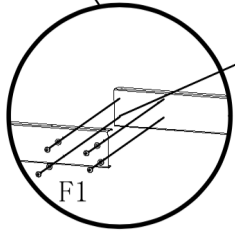

x2

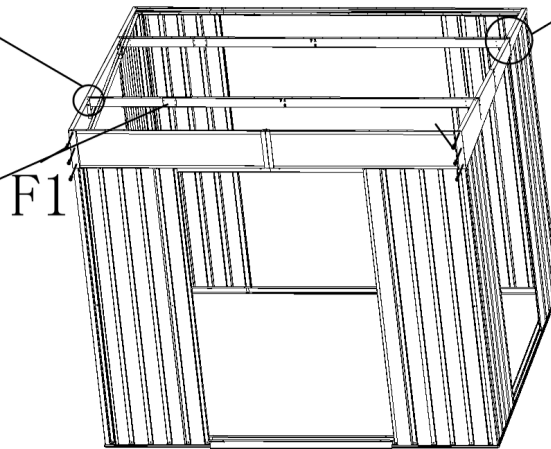

F1

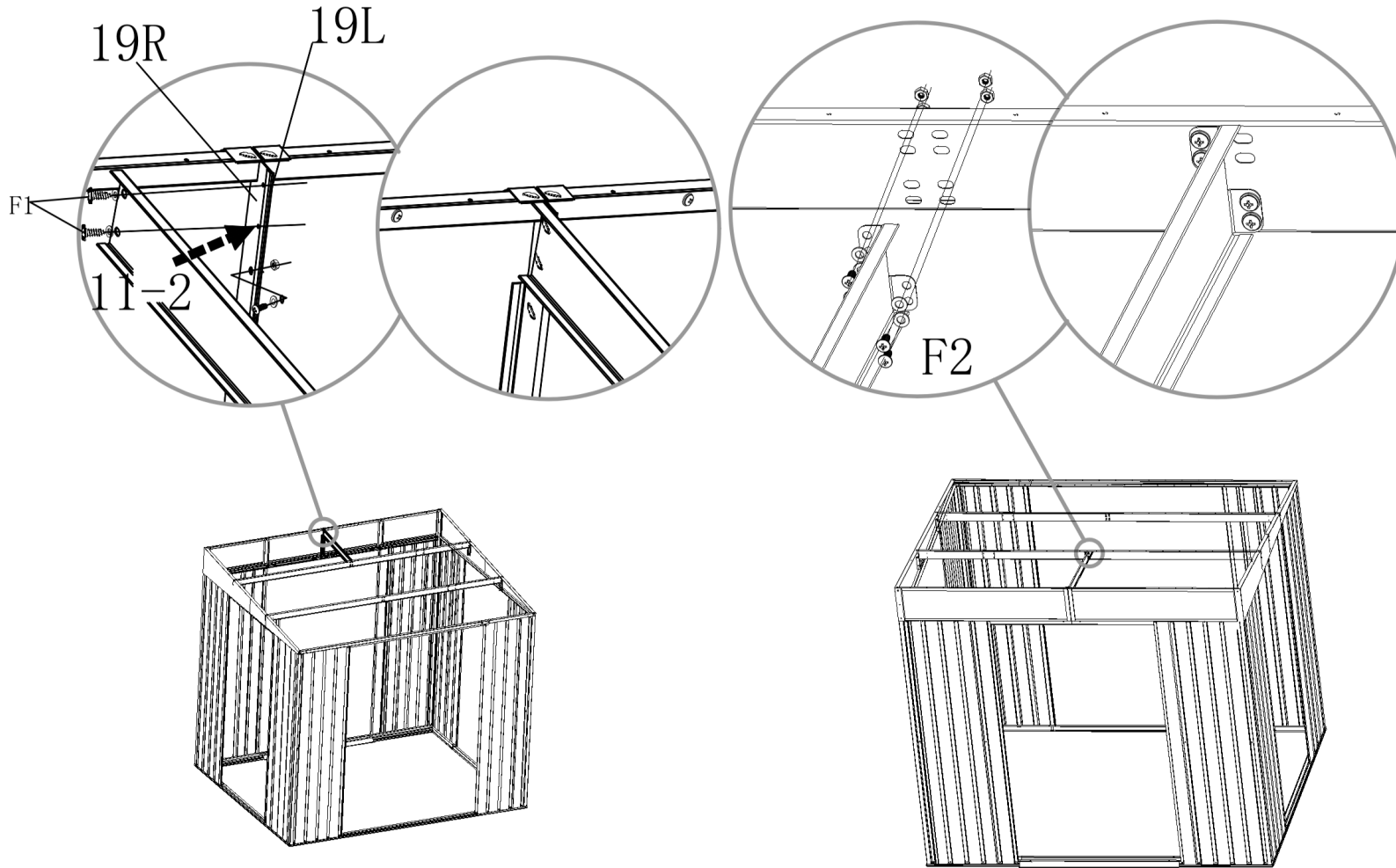
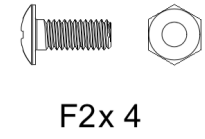
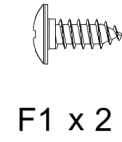
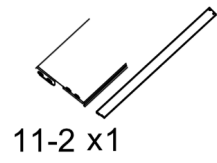

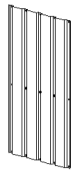

P1 x 9

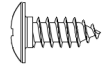

F1 x 78



F2 x 12



S3 x 90

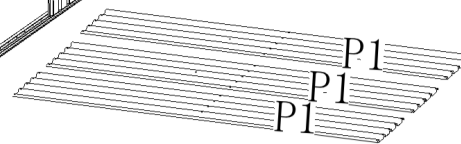
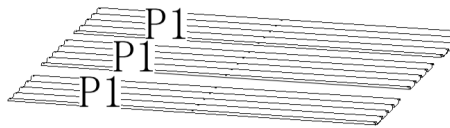
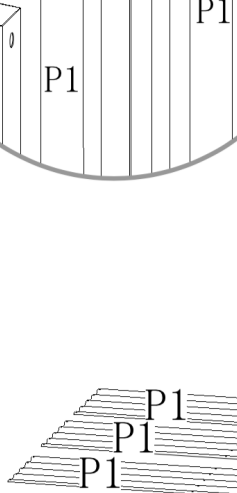
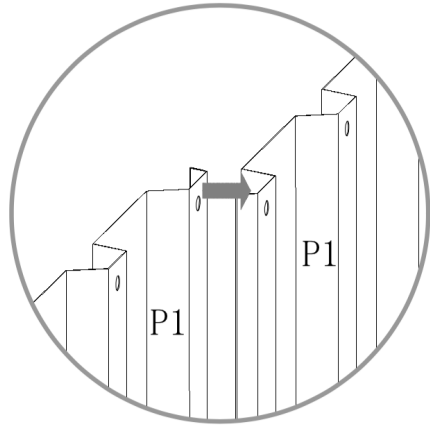

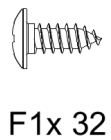
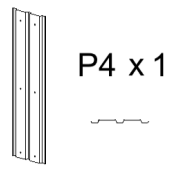
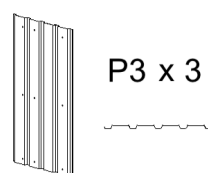
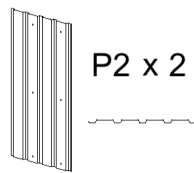

I

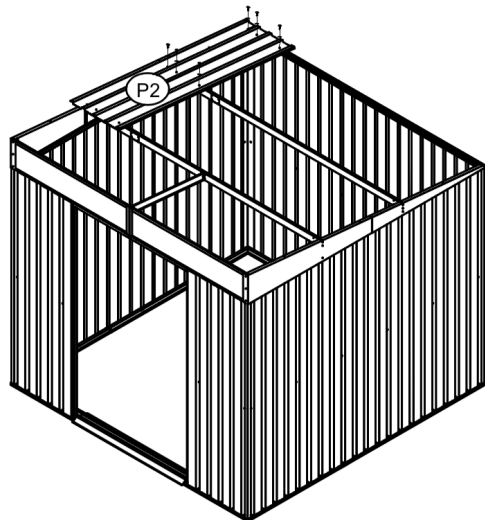

II

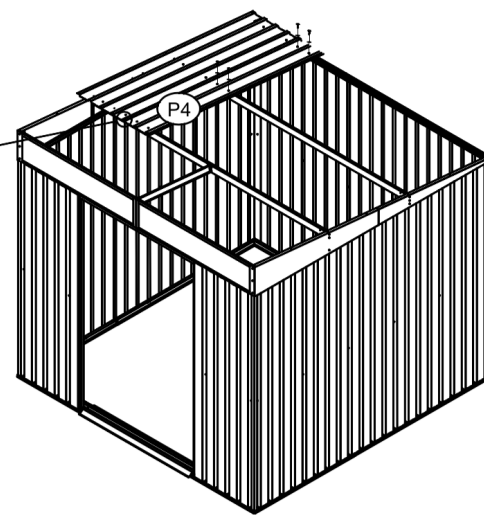
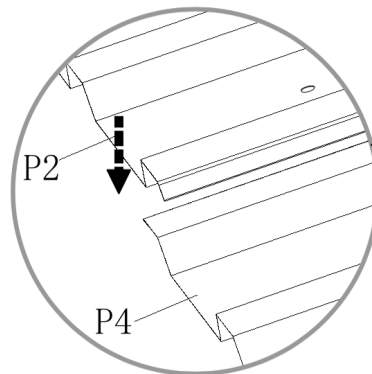

III

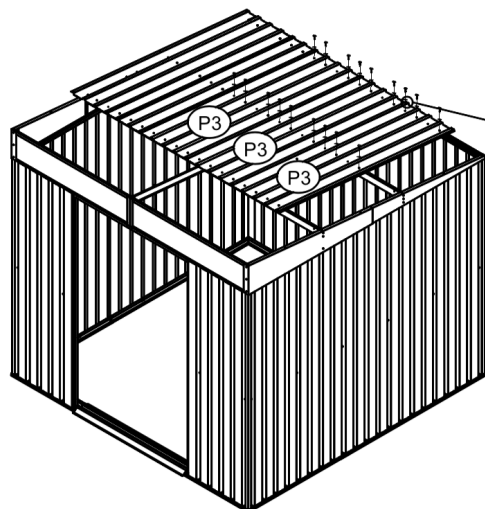

IV

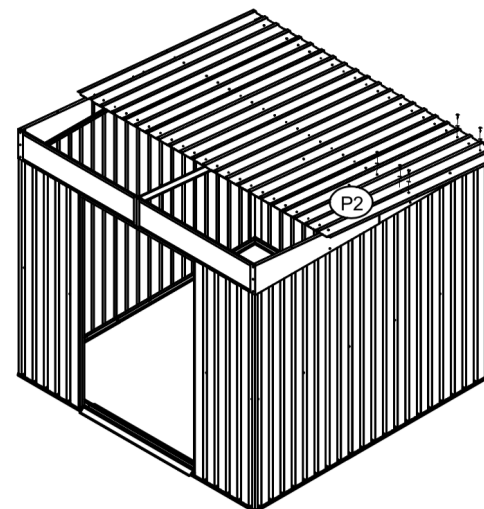
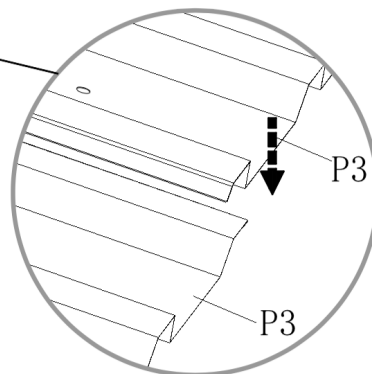

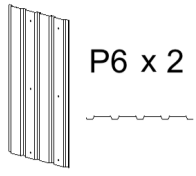

P6 x 2

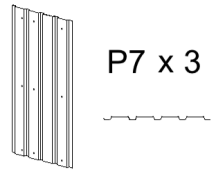

P7 x 3

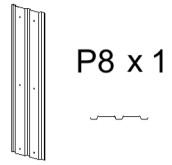

P8 x 1

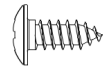

F1 x 30



S3 x 30

I

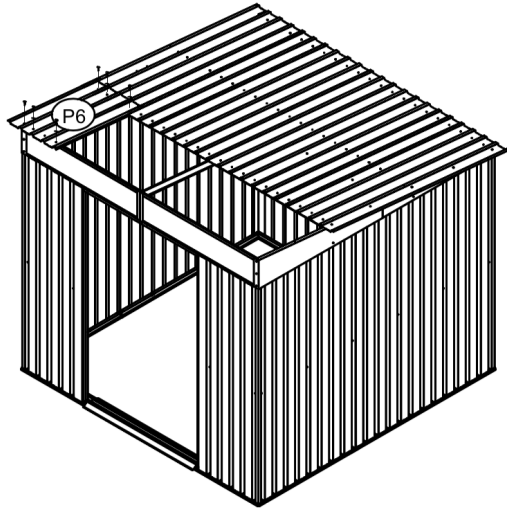

II

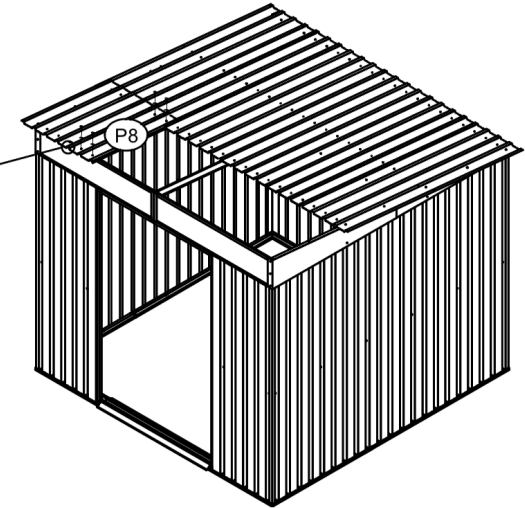
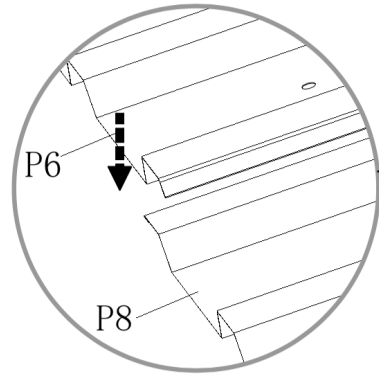

III

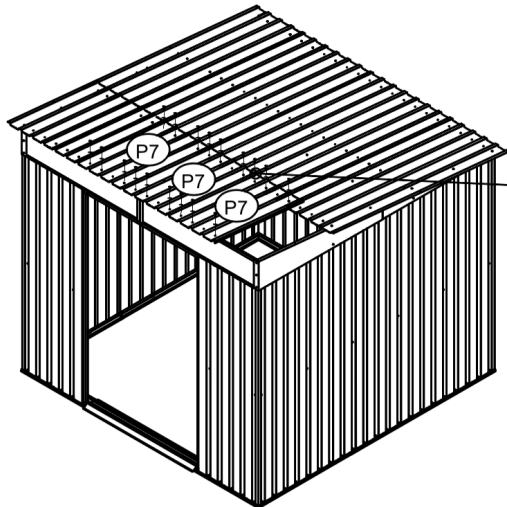

IV

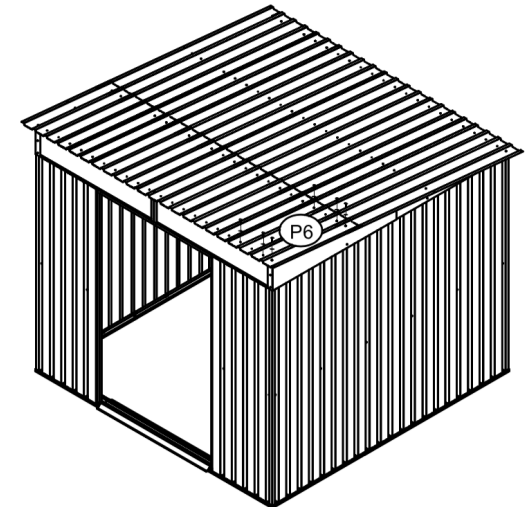
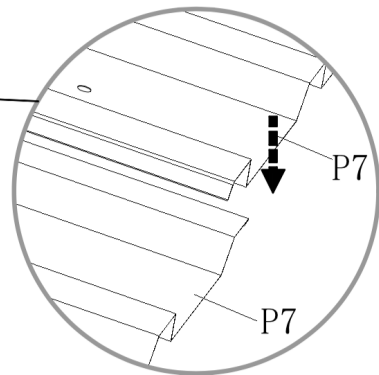



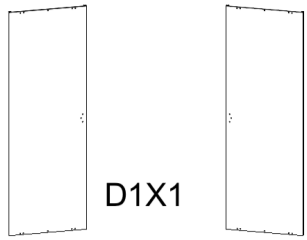

D1X1

D2X1

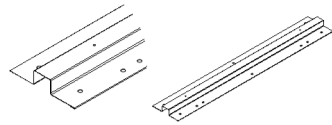

18 x 6

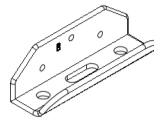

GBx 2

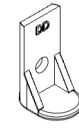

GDx 4

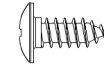

F1x 12



F2x 22



S3x 34

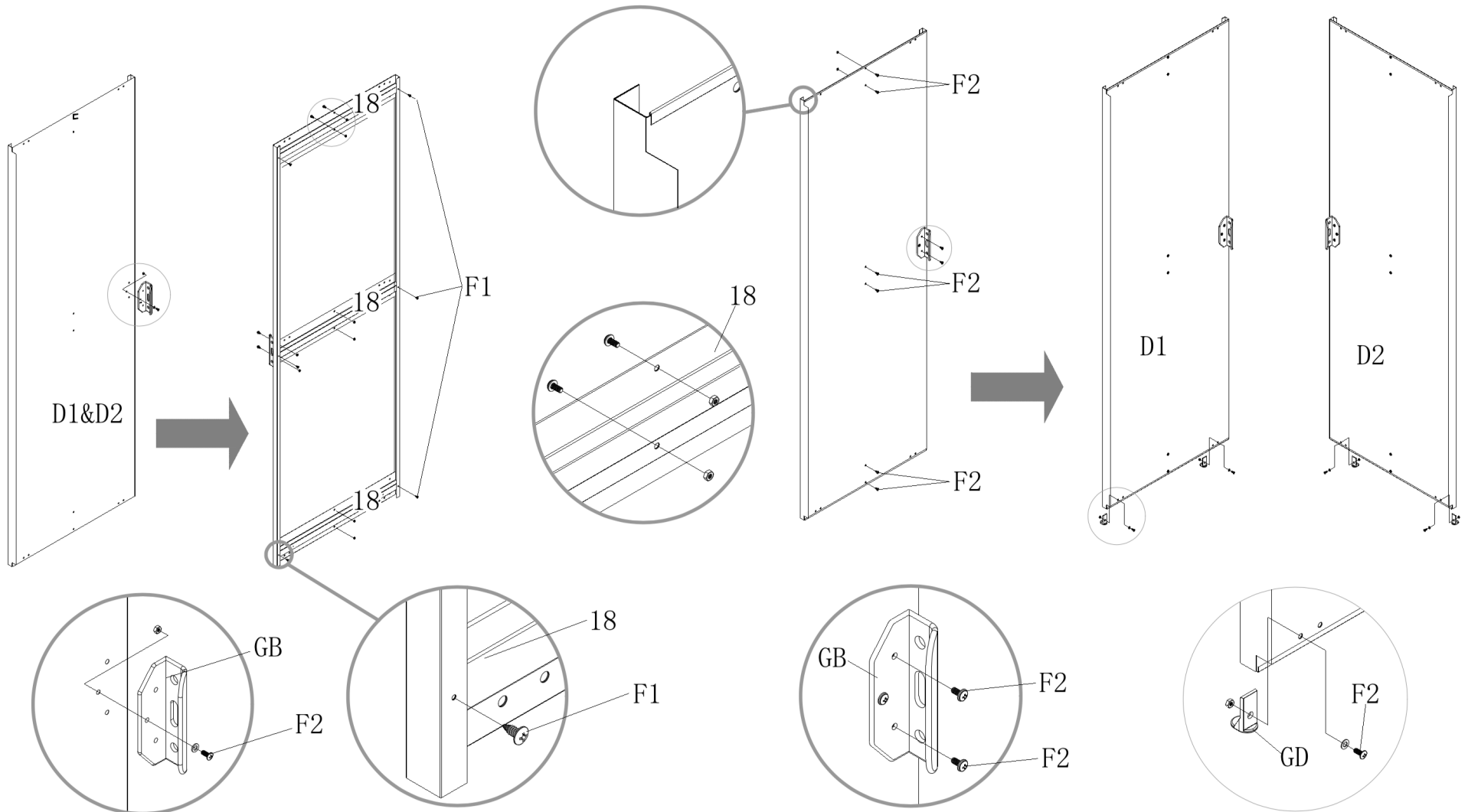

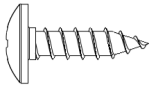

F3x 8

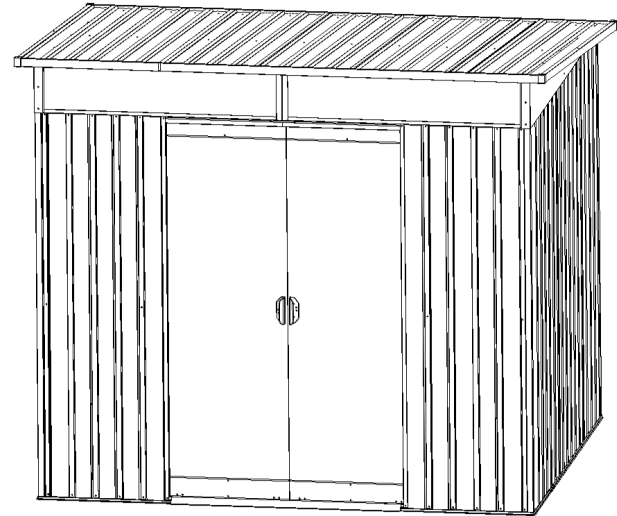
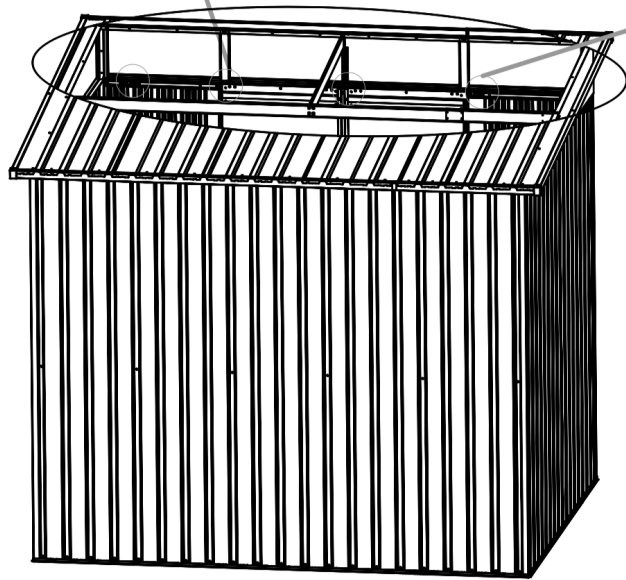
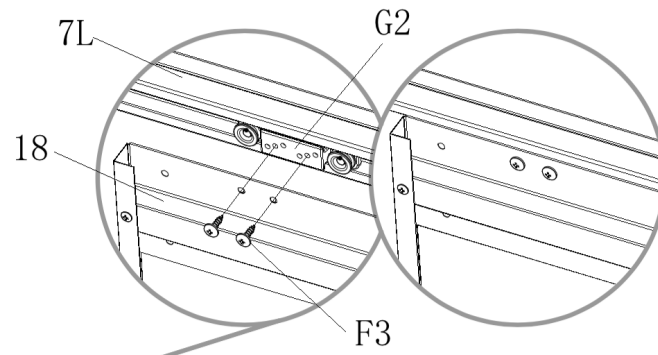
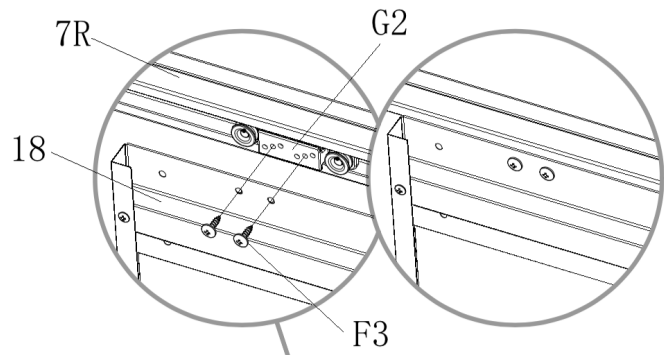



***Hoggar***<sup>®</sup>

Okoru Global S.L.U.

Poligono Industrial de Barros - 39408 - Cantabria - Spain