

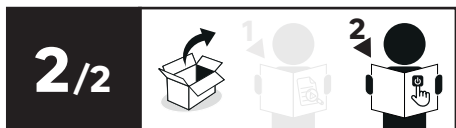

Waiki

EAN CODE: 3276007464566

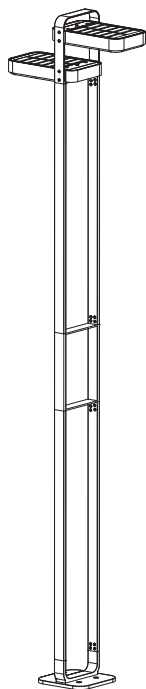

2022/07-V01

FR Manuel d'Instructions

EL Εγχειρίδιο Οδηγών

DE Anleitung Handbuch

ES Manual de Instrucciones

PL Instrukcja Obsługi

EN Instructions Manual

PT Manual de Instruções

UA Інструкція з Експлуатації

IT Manuale di Istruzioni

RO Manual de Instrucțiuni

*Année de garantie / años de garantía / Ano de garantia / Anno di garanzia / Έτος εγγύησης / Rok gwarancji / Гарантіяроків / Anul de garanție / Jahr der Garantie / Year of guarantee

**réparable / reparable / reparável / riparabile / διορθώσιμος / naprawiany / ремонтний / reparabil / reparaturfähig / repairable



FR:Montage / ES:Montaje / PT:Montagem / IT:Montaggio / EL:Συναρμολόγηση /
PL:Montaż / UA:Збірка / RO:Montaj / DE:Montage / EN:Assembly



4 → 8



FR:Utilisation / ES:Utilización / PT:Utilização / IT:Uso / EL:Χρήση / PL:Użytkowanie /
UA:Використання / RO:Utilizare / DE:Verwenden Sie / EN:Use



9 → 14



FR:Le pilote, la batterie et le module LED de la lampe peuvent être remplacés/ES:El controlador,
la batería y el módulo LED de la lámpara pueden ser sustituidos /PT:O controlador, a bateria e o
módulo do LED do candeeiro podem ser substituídos /IT:Il driver, la batteria e il modulo LED della
lampada possono essere sostituiti/EL:Το πρόγραμμα οδήγησης και η μπαταρία και
Η μονάδα LED στη λάμπα μπορεί να αντικατασταθεί/PL:Sterownik i bateria oraz moduł LED w
lampie mogą być wymieniane/UA:Драйвер, акумулятор і світлодіодну панель лампи можна
заміняти. RO:Starterul, bateria și modulul LED din lampă pot fi înlocuite/DE:Der Treiber sowie die
Batterie und das LED-Modul in der Lampe können ausgetauscht werden/EN:The driver and
battery and LED module in lamp can be replaced



15 → 17

FR : CARACTERISTIQUES TECHNIQUES / ES : CARACTERÍSTICAS TÉCNICAS / PT : CARACTERÍSTICAS TÉCNICAS /
IT : CARAT-TERISTICHE TECNICHE / EL : ΤΕΧΝΙΚΑ ΧΑΡΑΚΤΗΡΙΣΤΙΚΑ / PL : DANE TECHNICZNE / UA : ΤΕΧΝΙΧΗ
ΧΑΡΑΚΤΕΡΙΚΗ / RO : CARACTERISTI TECHICE / DE : TECHNISCHE MERKMALE / EN : TECHNICAL CHARACTERISTICS



1 / 2



1



4



6

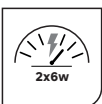

9



12



19



20



26

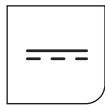

31



34



35

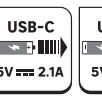
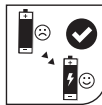

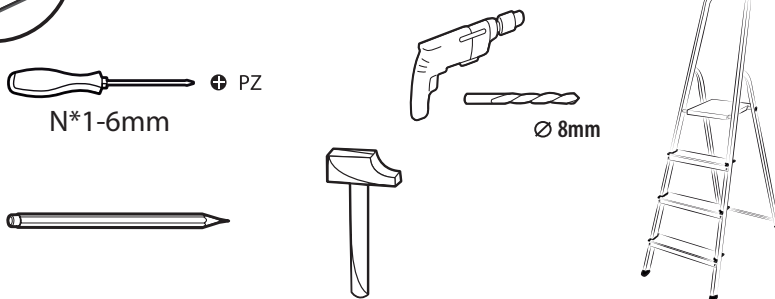
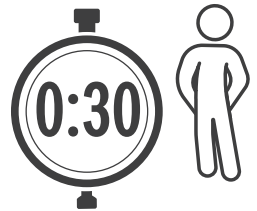
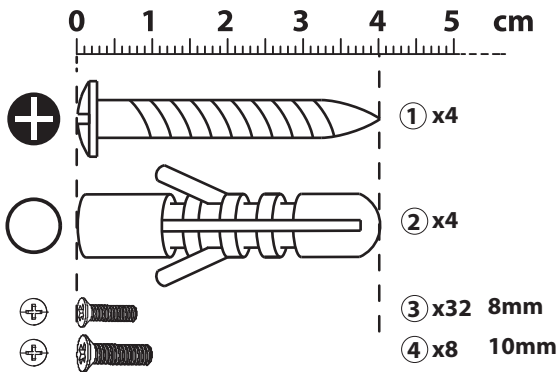
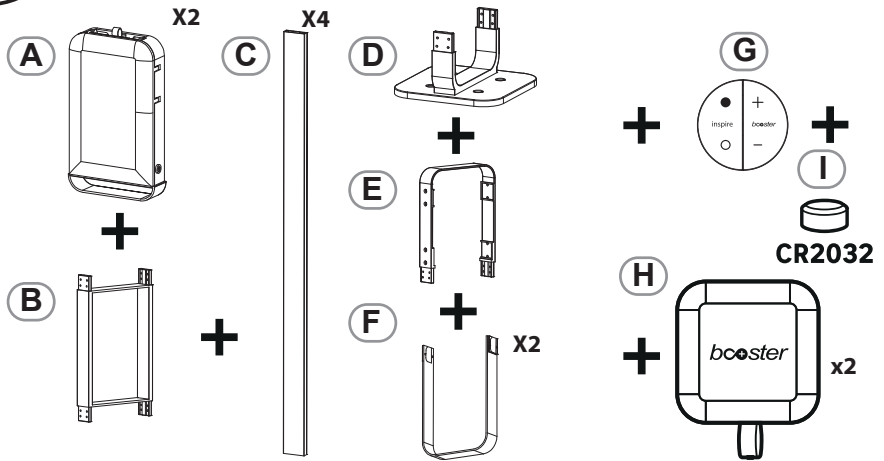

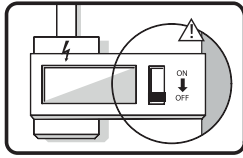

1

1

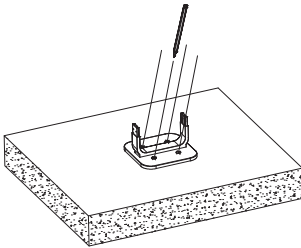

2

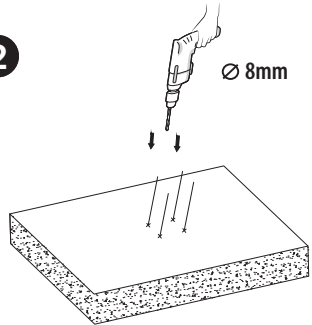

2

3

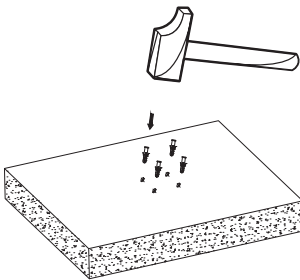

4

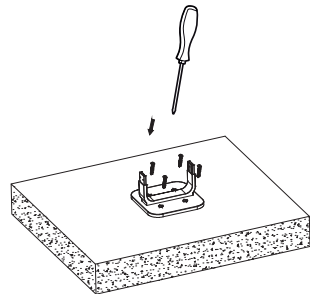

*



+



*Utiliser les vis et chevilles adaptées à votre support - Utilice tornillos y tacos adecuados para el soporte - Utilize buchas e parafusos adaptados à superfície de instalação - Utilizzare viti e tasselli adeguati al proprio supporto - Χρησιμοποιήστε τις κατάλληλες βίδες και ούλα για τον τοίχο σας - Используйте шурупы/крепления, которые подходят к основанию, к которому они будут крепиться - Використуйте гвинти та штифти, що підходять для поверхні, на яку Ви монтуєте ролет/жалюзі - Należy korzystać ze śrub i kółków przystosowanych do nośnika - Utilizați șuruburile și diblurile adecvate suportului dvs - Use screws and dowels suited to your backing.

3

5

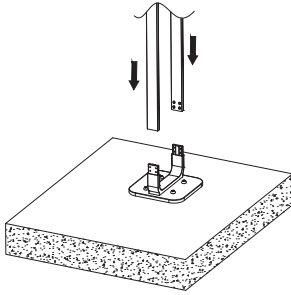

6

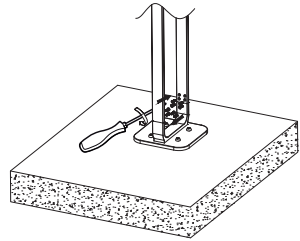

4

7

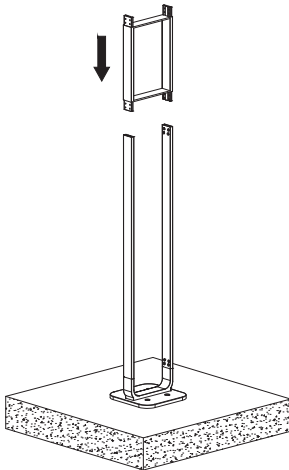

8

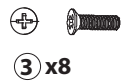
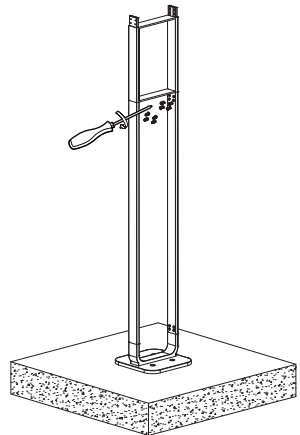

5

9

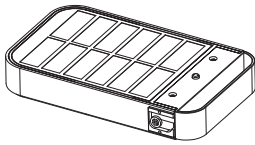

x2

10

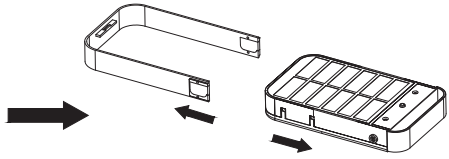

6

11

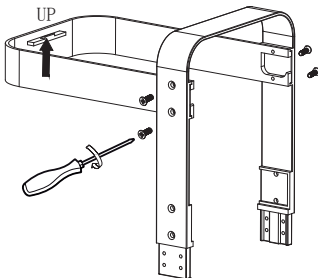

12

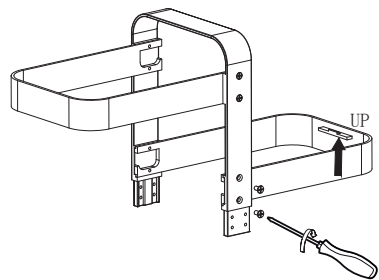

4 x8

7

13

14

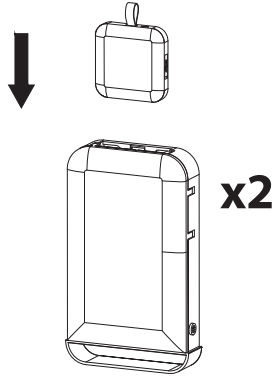

8

15

16

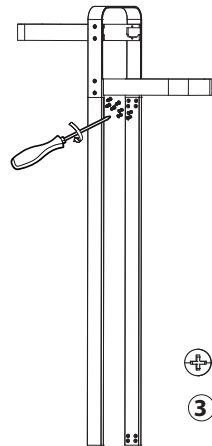
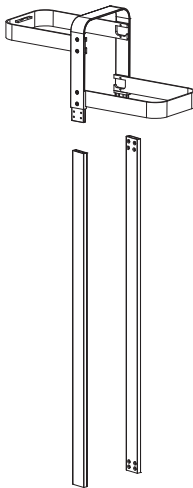

9

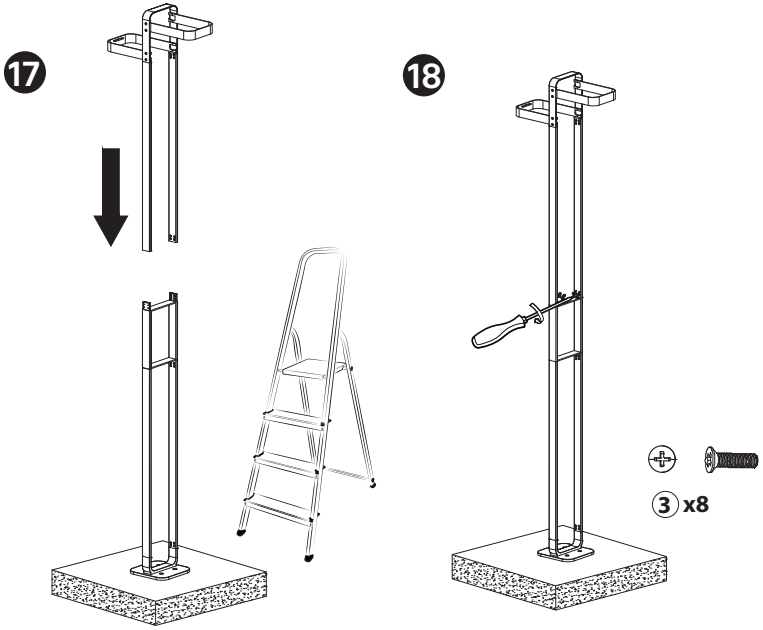

10

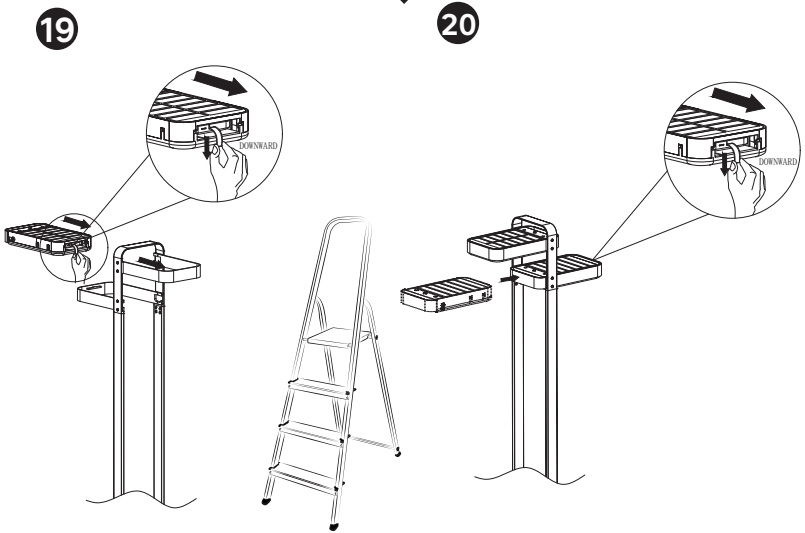

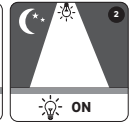
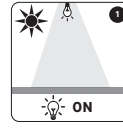
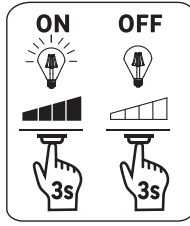
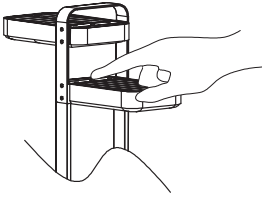

1

100LM



1



300LM



2



600LM



3



900LM



4

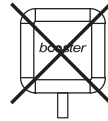

100LM



300LM



600LM



900LM

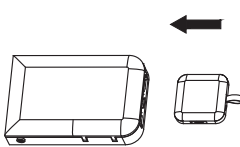

100LM



300LM



600LM



900LM



2

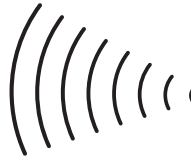
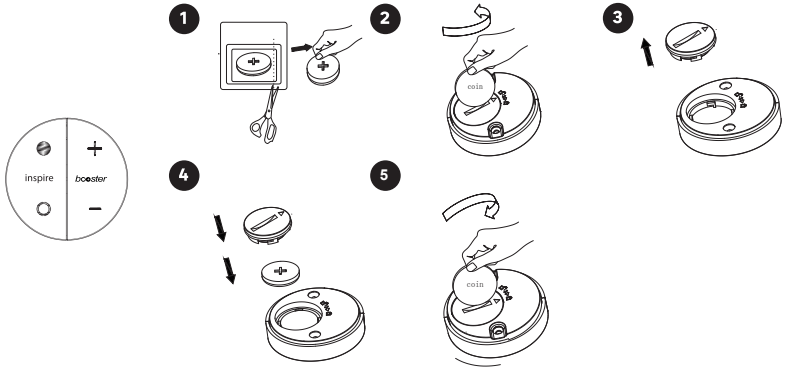

10m

Operation Frequency: 2407MHz
Max. RF output power: -8.12 dBm

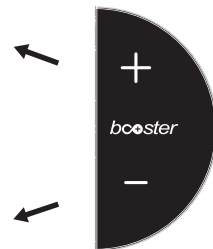
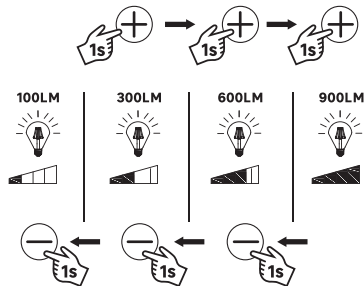
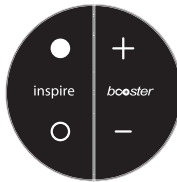

3

 **booster**

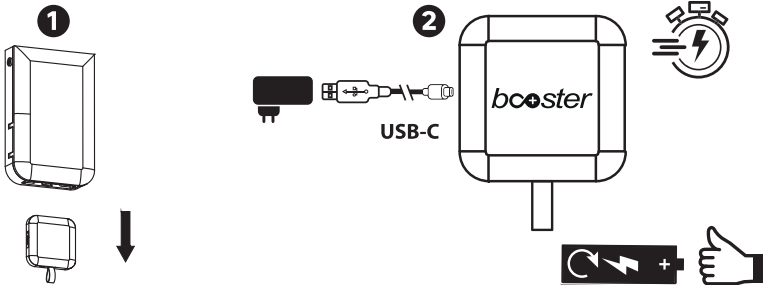
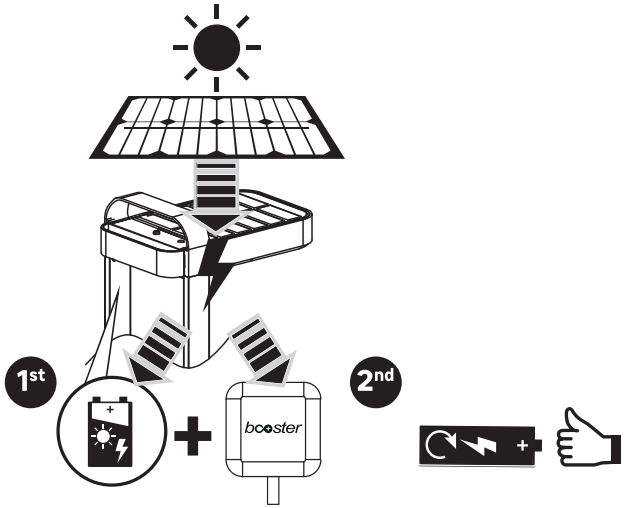
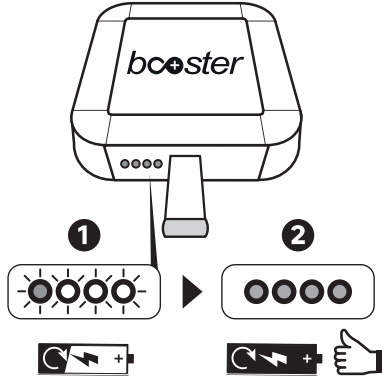

4

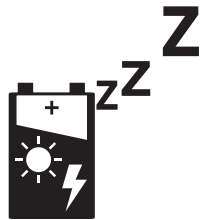
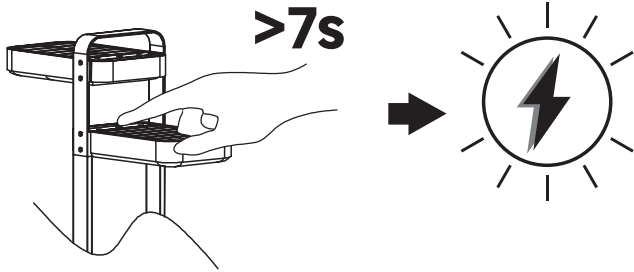

=

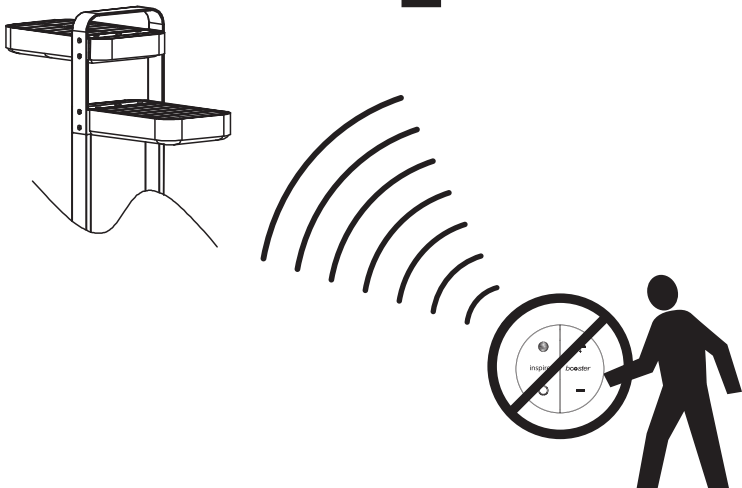

5



1



1st



2nd



<30S

2

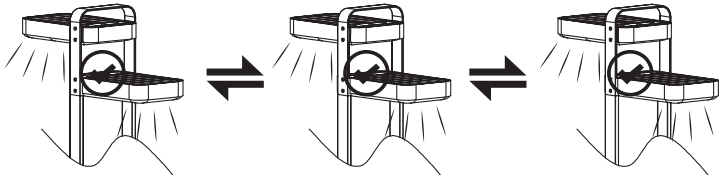
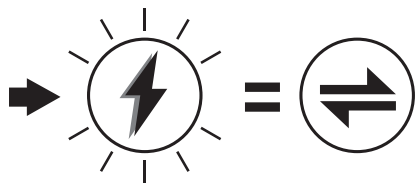
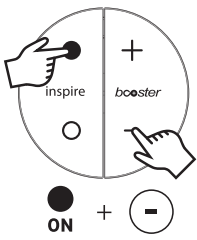

6

flash 2 times

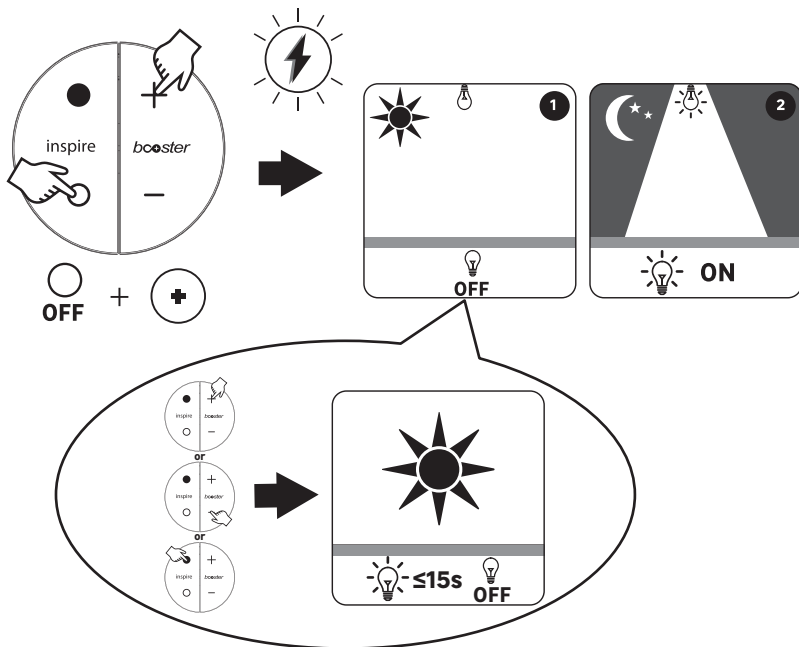

flash 2 times

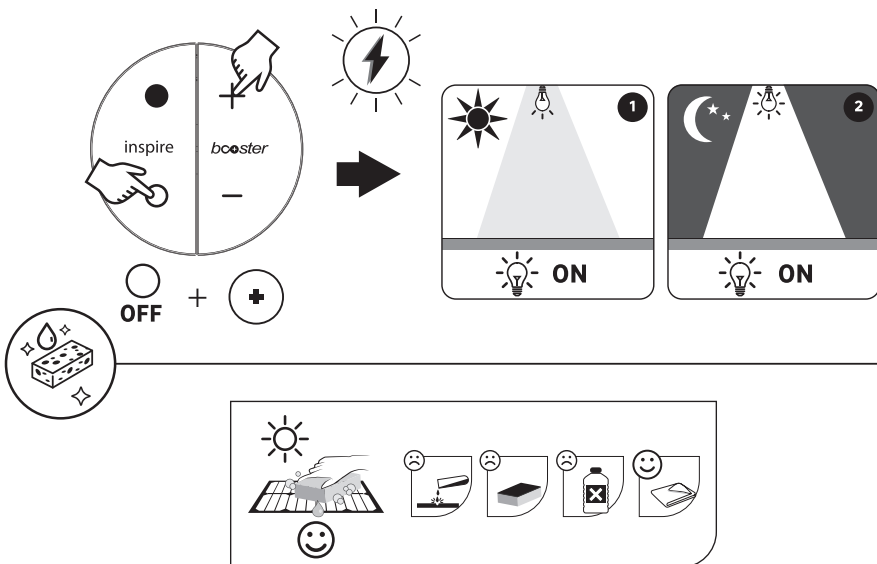

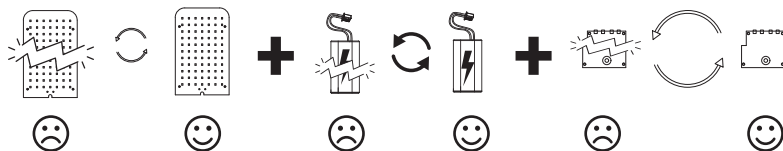

1

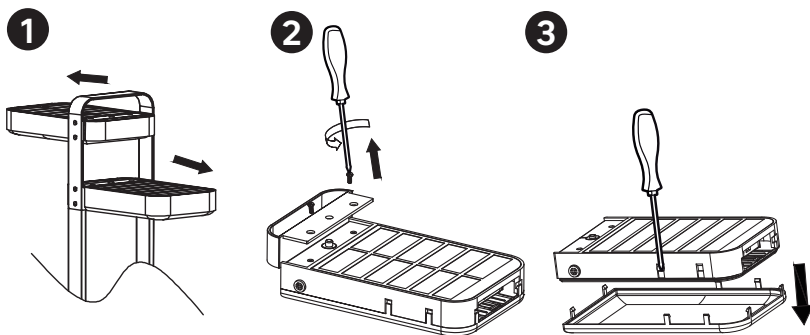

2

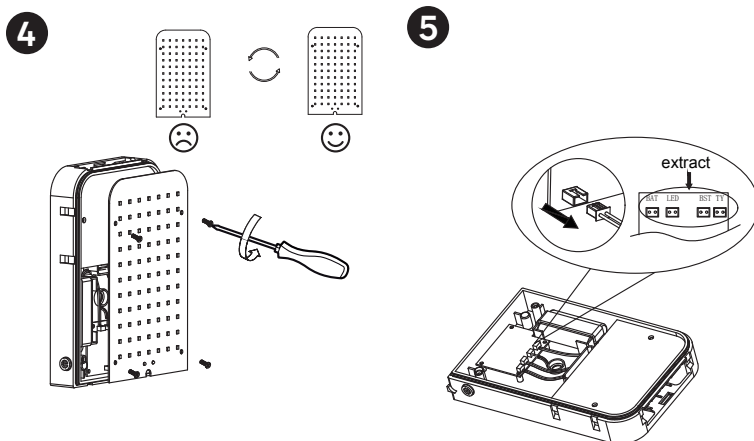

3

6

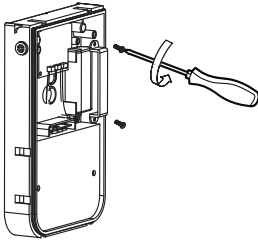
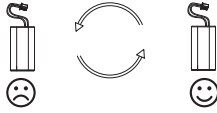

7

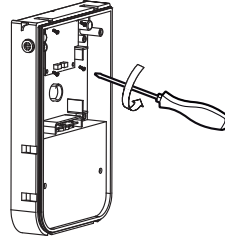
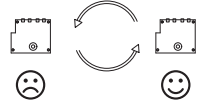

4

8

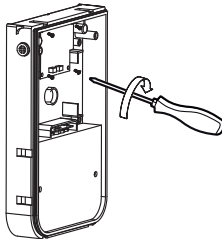

9

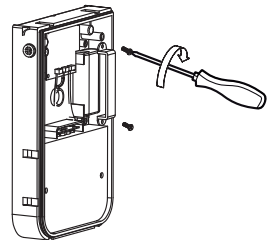

5

10

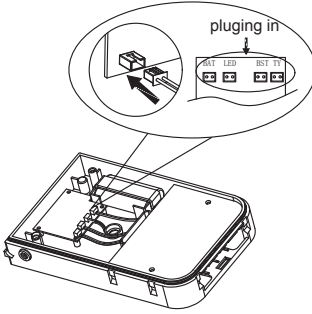

11

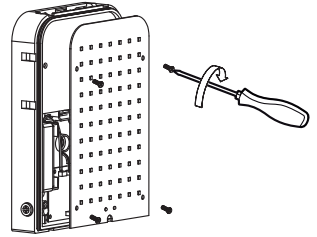

6

12

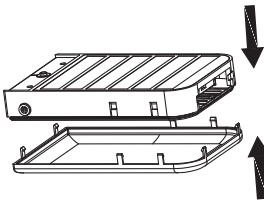

13

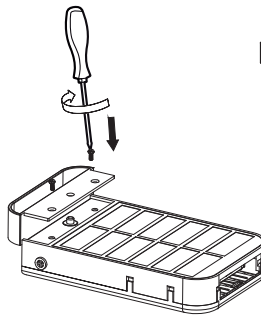

14

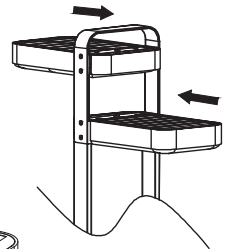



Ce produit se recycle,
s'il n'est plus utilisable
déposez-le en déchèterie.

Notice à trier.

Pour en savoir plus :
www.quefairedemesdechets.fr

- FR** Ce produit est recyclable. S'il ne peut plus être utilisé, veuillez l'apporter dans un centre de recyclage de déchets.
- ES** Este producto es reciclable. Si ya no se puede usar, llévalo a un centro de reciclaje de residuos.
- PT** Este produto é reciclável. Se deixar de o utilizar, entregue-o num centro de reciclagem de resíduos.
- IT** Questo prodotto può essere riciclato. Se deve essere smaltito, portalo presso un centro di riciclaggio.
- EL** Αυτό το προϊόν είναι ανακυκλώσιμο. Εάν δεν μπορεί πλέον να χρησιμοποιηθεί, μεταφέρετε την σε κάποιο κέντρο ανακύκλωσης απορριμμάτων.
- PL** Ten produkt poddawany jest recyklingowi, kiedy przestaje być użyteczny należy dostarczyć go do punktu zbiórki odpadów.
- UA** Цей продукт може перероблятися. Якщо воно більше не є придатне для використання, здайте його в утилізаційний центр.
- RO** Aceast produs este reciclabil. Dacă nu mai poate fi folosit, vă rugăm să îl aduceți într-un centru de reciclare a deșeurilor.
- DE** Dieses Produkt ist recycelbar. Wenn es nicht mehr verwendet werden kann, bringen Sie es bitte zum Wertstoffhof
- EN** This product is recyclable. If it cannot be used anymore, please take it to waste recycling centre.



Traduction de la version originale du mode d'emploi / Traducción de las Instrucciones originales / Tradução das Instruções Originais / Traduzione delle istruzioni originali / Μετάφραση των πρωτότυπων οδηγιών / Tłumaczenie instrukcji oryginalnej / Переклад оригінальної інструкції / Traducerea instrucțiunilor originale / Originalanleitung / Original Instructions

ADEO Services - 135 Rue Sadi Carnot - CS 00001 - 59790 RONCHIN - France

UA Виробник: ТОВ "Адео Сервісез С.А.", вул. Саді Карно, CS 00001, 59790 Роншєн, Франція.
Імпортер: ТОВ "Лєруа Мерлен Україна", 04201 Україна, м.Київ, вул. Полярна 17А, +380 44 498 46 00.
Імпортер приймає претензії від споживачів щодо товару, а також проводить його єремонт, технічне і гарантійне обслуговування

BR IMPORTADO E DISTRIBUÍDO POR:
LEROY MERLIN COMPANHIA BRASILEIRA
DE BRICOLAGEM CNPJ: 01.438.784/0001-05
Rua Pascoal Pais, nº. 525, 6º andar, cj 61 a 64 -
Vila Cordeiro, São Paulo - SP CEP: 04581-060
CALM (Central de Atendimento Leroy Merlin)
Capitais 4020-5376 Demais Regiões 0800-0205376
IMAGEM ILUSTRATIVA

ZA Imported by Adeo South Africa (PTY) LTD T/A Leroy Merlin/Leroy Merlin Greenstone Store/Corner Blackrock Street and Stoneridge Drive, Greenstone Park Ext 2, Edenvale, 1610 Johannesburg, Gauteng, South Africa

Made in China
Країнапоходження: Китай