

Instrucciones de montaje
Instruções de montagem
Assembly instructions
Instructions d'assemblage

FINIar

Alto multiusos 79
Superior multi-usos 79
Multipurpose wall cabinet 79
Armoire haute polyvalente 79

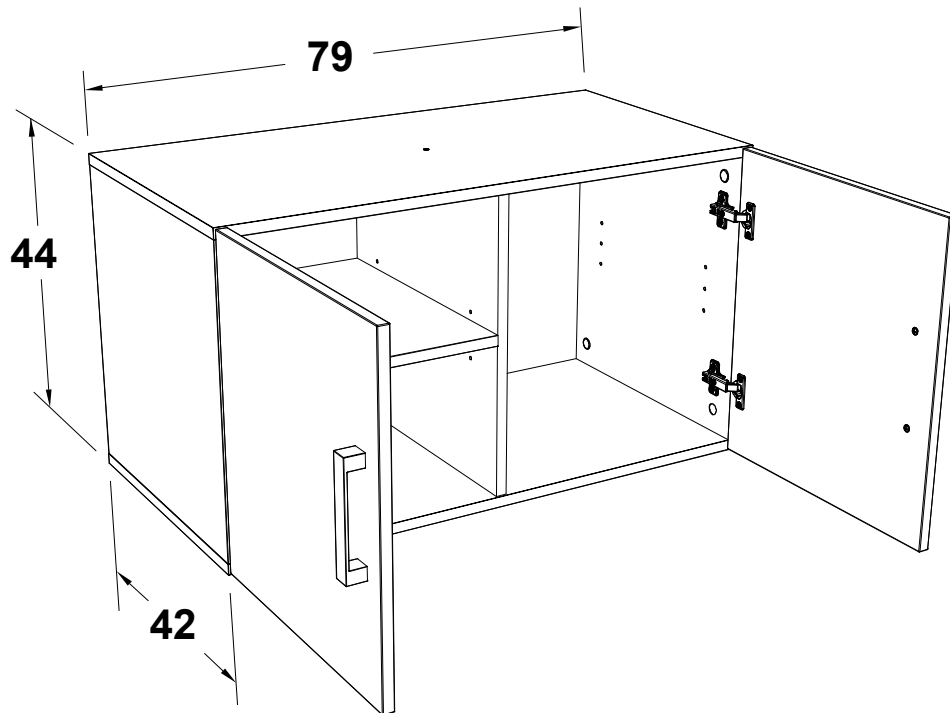

Finsa

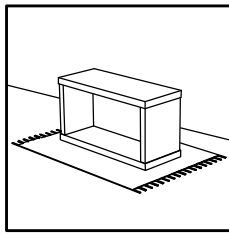
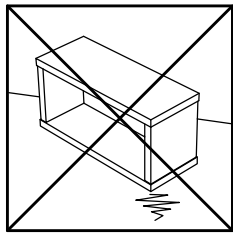
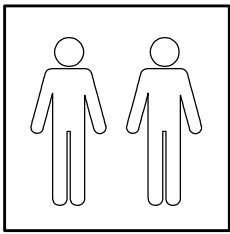

Vídeo de montaje
Vídeo de montagem
Assembly video
Vidéo de montage

QR

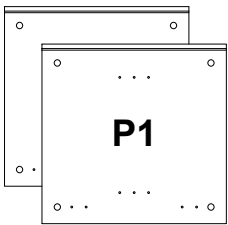
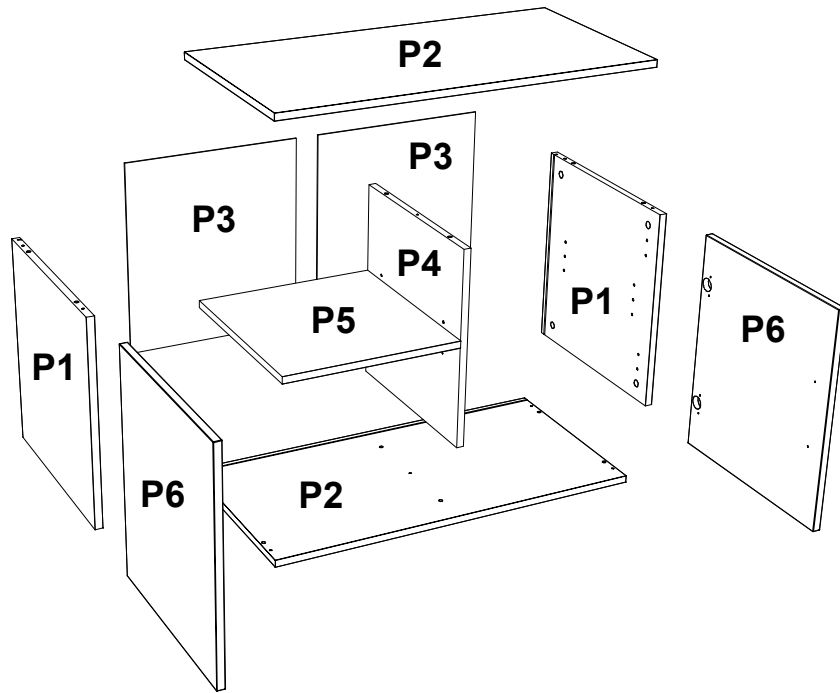

399 x 410 x 15

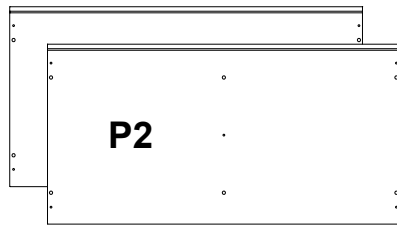

400 x 784 x 15

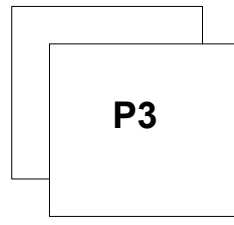

424 x 384 x 2.5

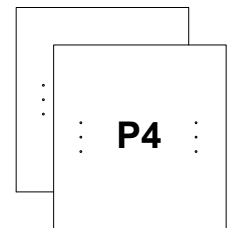

410 x 383.5 x 15

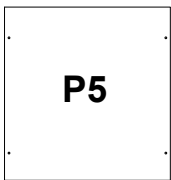

384.5 x 369 x 15

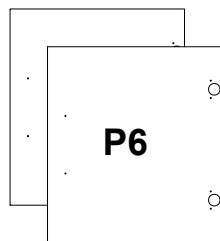

436 x 388 x 15

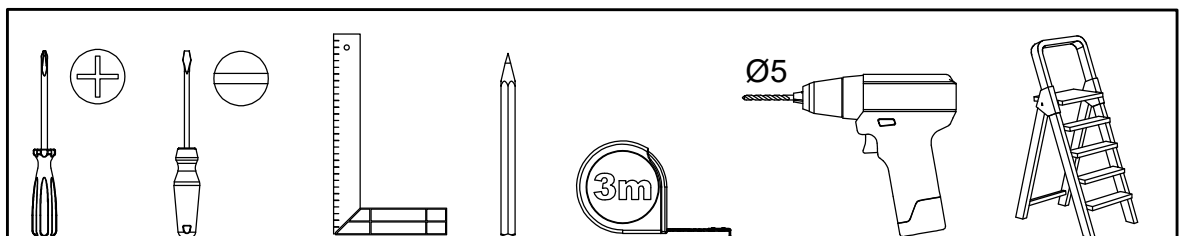
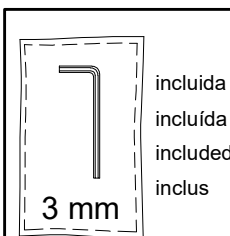

0 1 2 3 4 5 [cm]

A x12



B x4

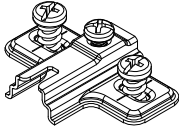

C x8

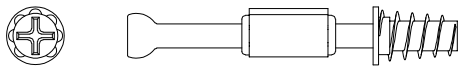

D x2

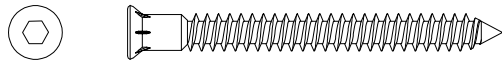

E x8

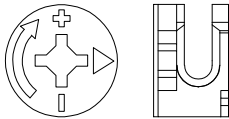

F x8

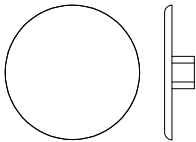

G x2

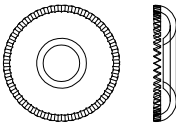

H x8

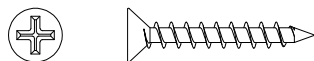

I x8

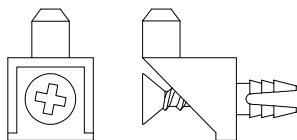

J x4

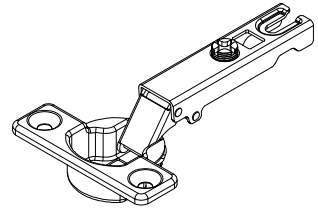

K x8



L x4

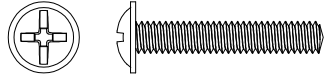

M x2

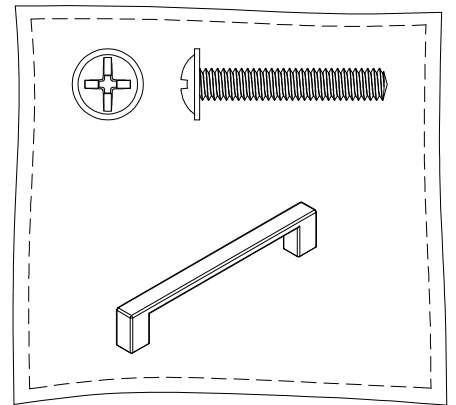

N x2

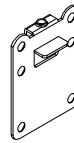

O x2

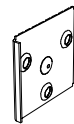

P x2

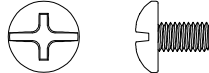

Q x16



1

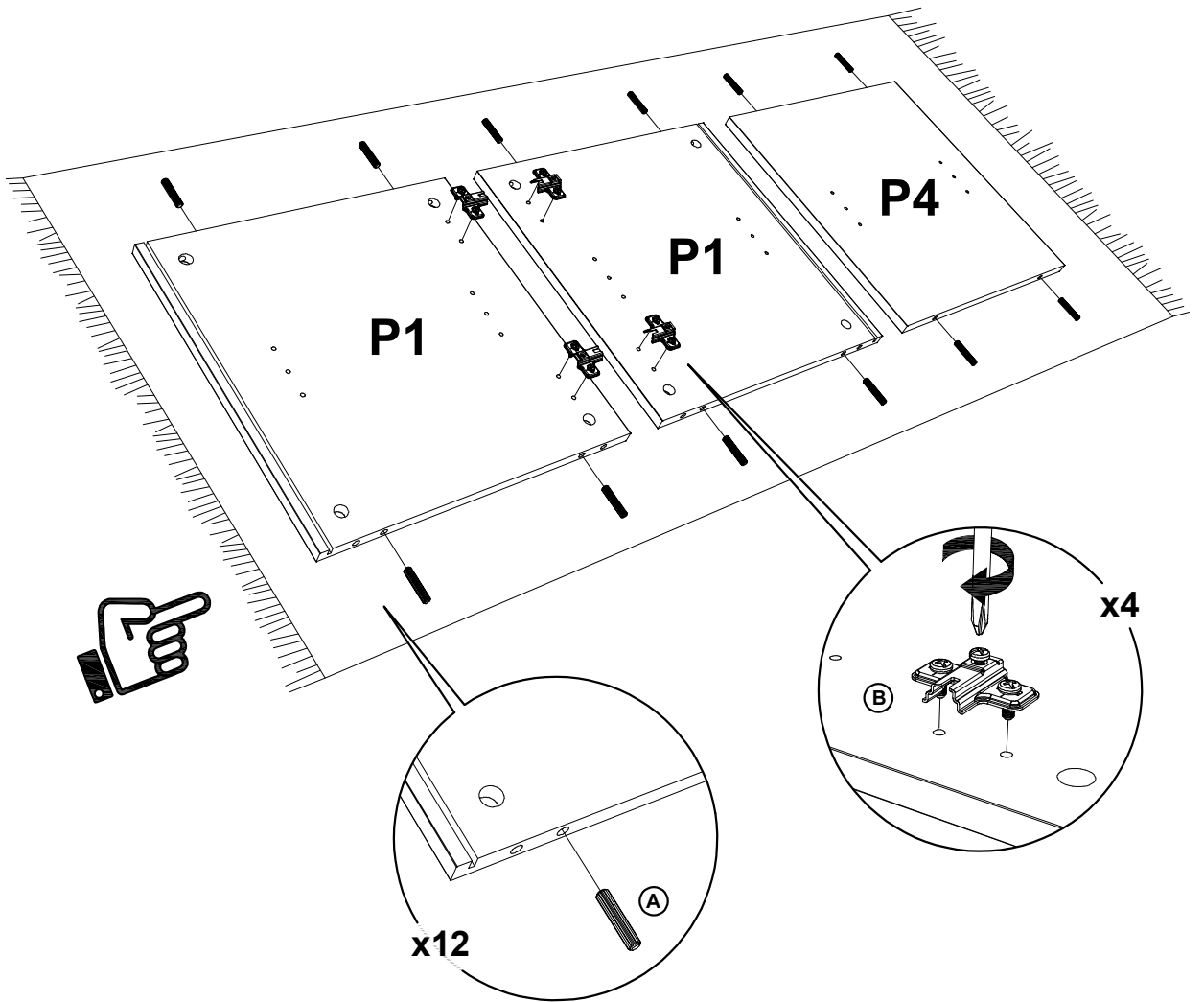
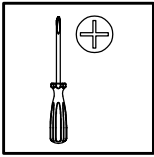
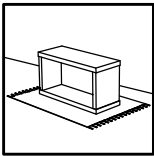

2

x2

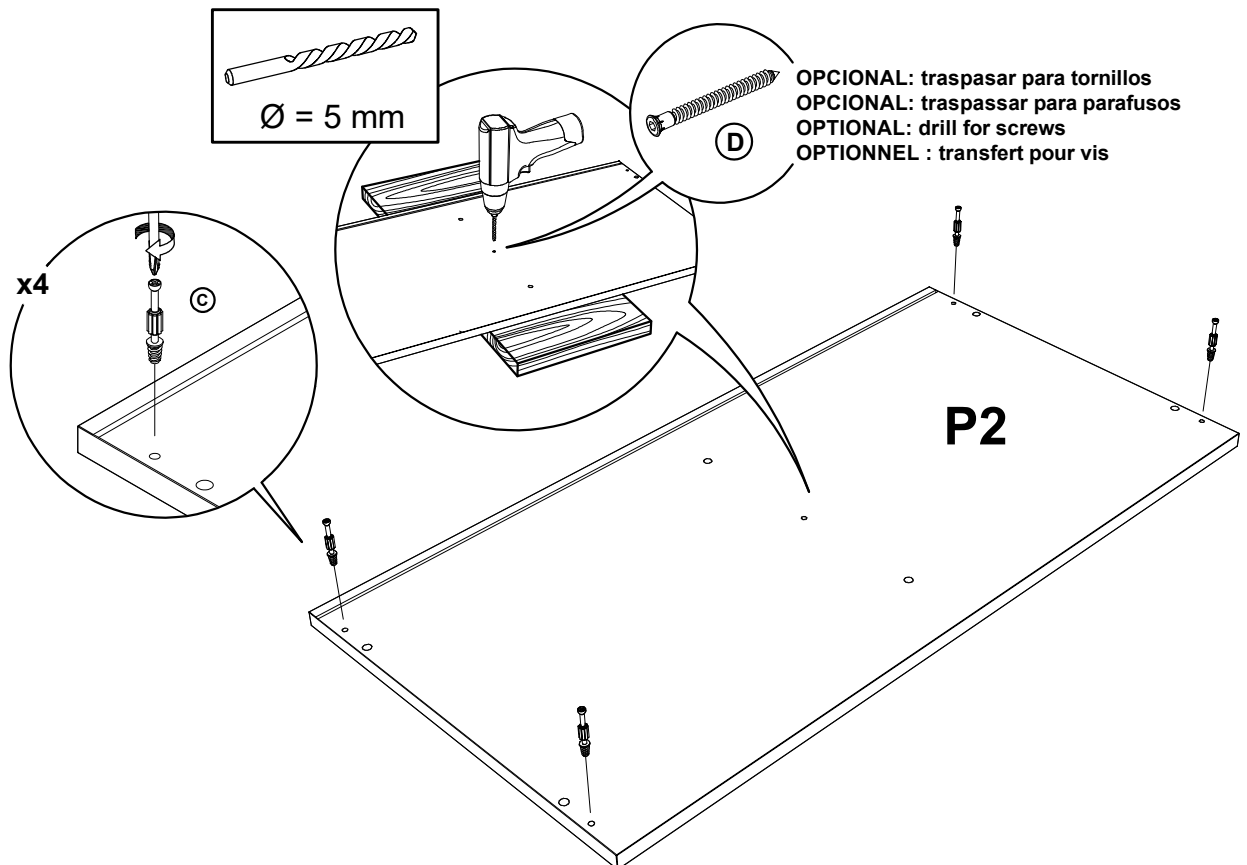
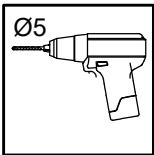
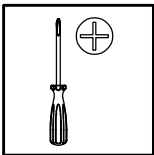

3

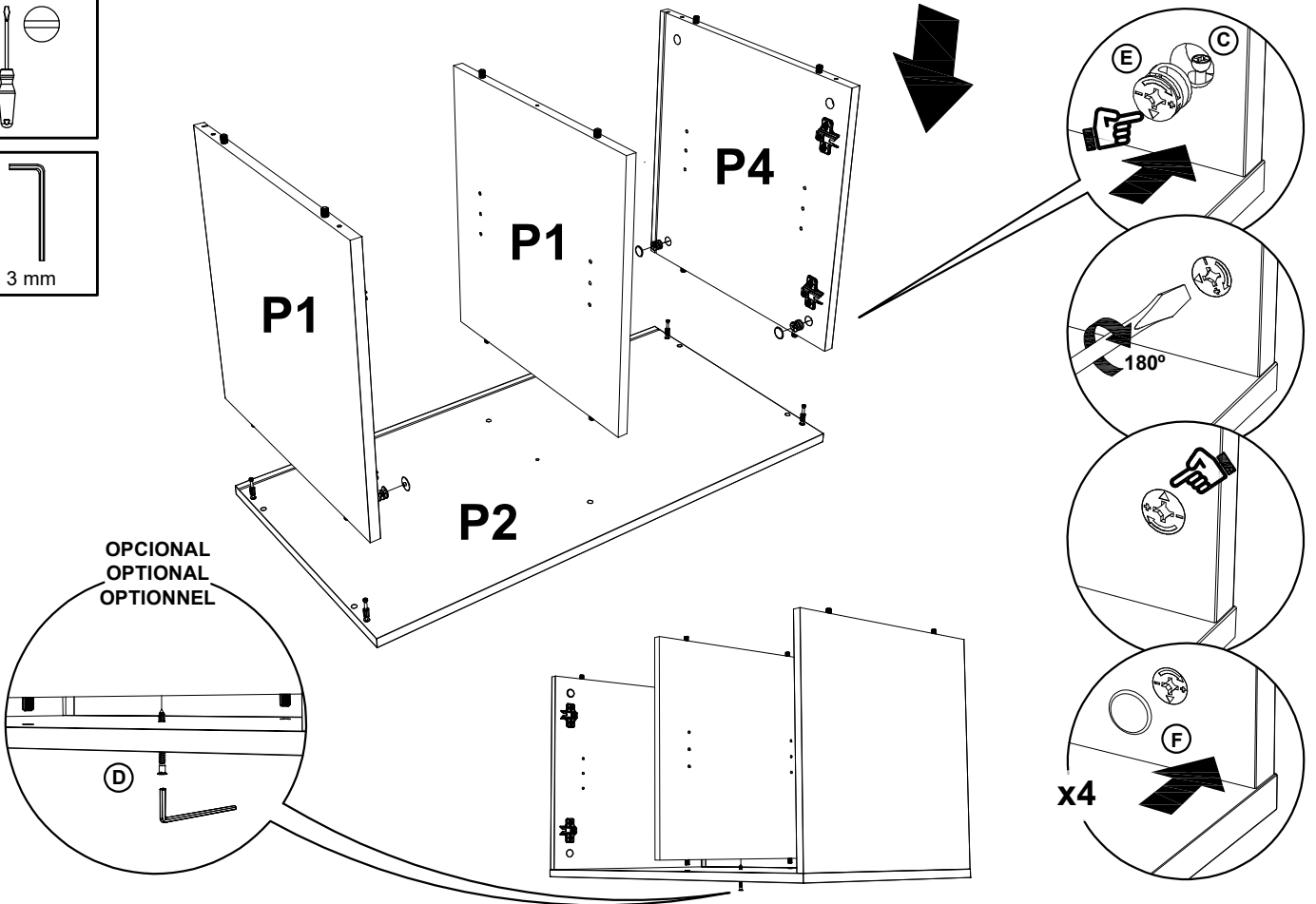
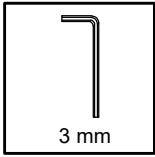
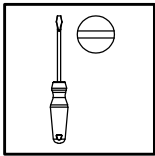

4

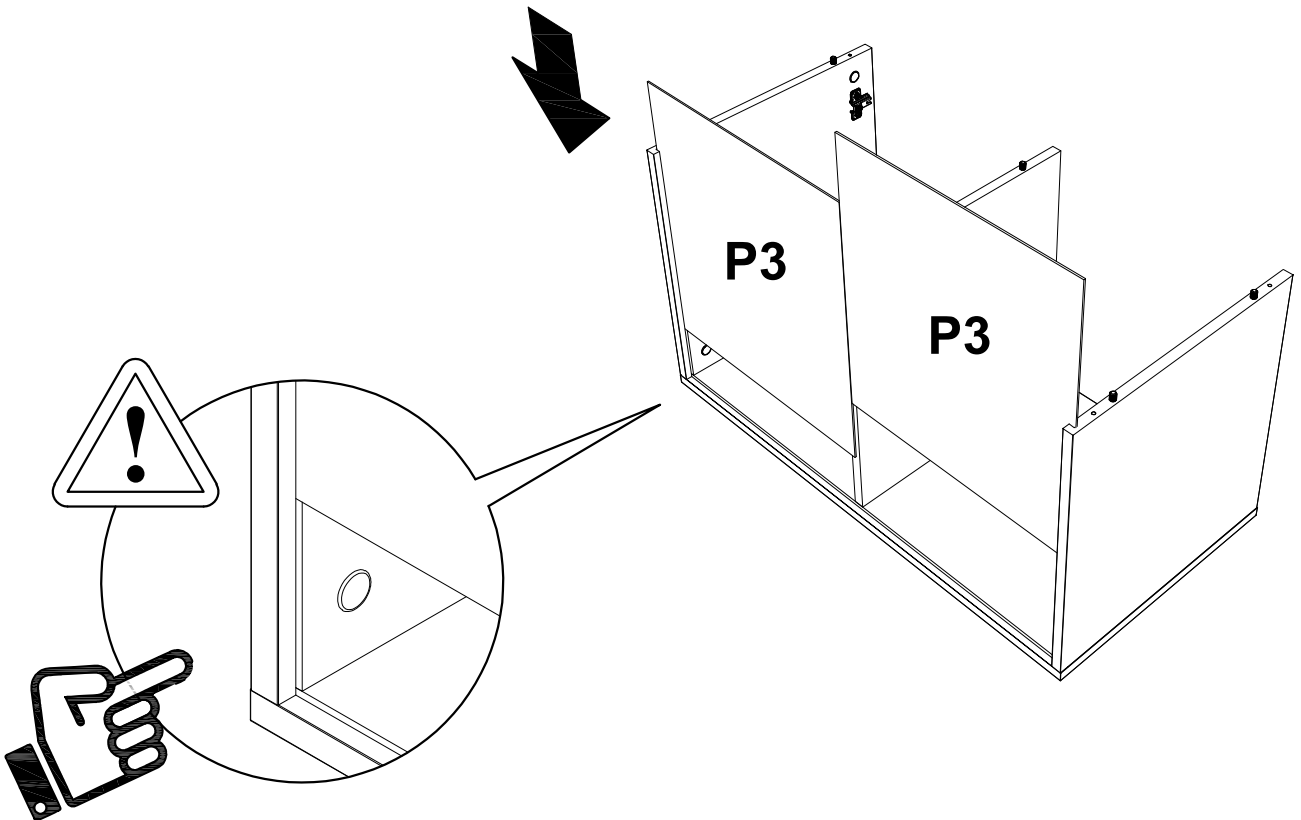

5

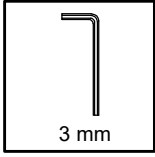
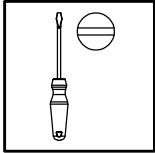

OPCIONAL: ver pasos 2 y 3
 OPCIONAL: ver passos 2 e 3
 OPTIONAL: see steps 2 and 3
 OPTIONNEL: voir les étapes 2 et 3

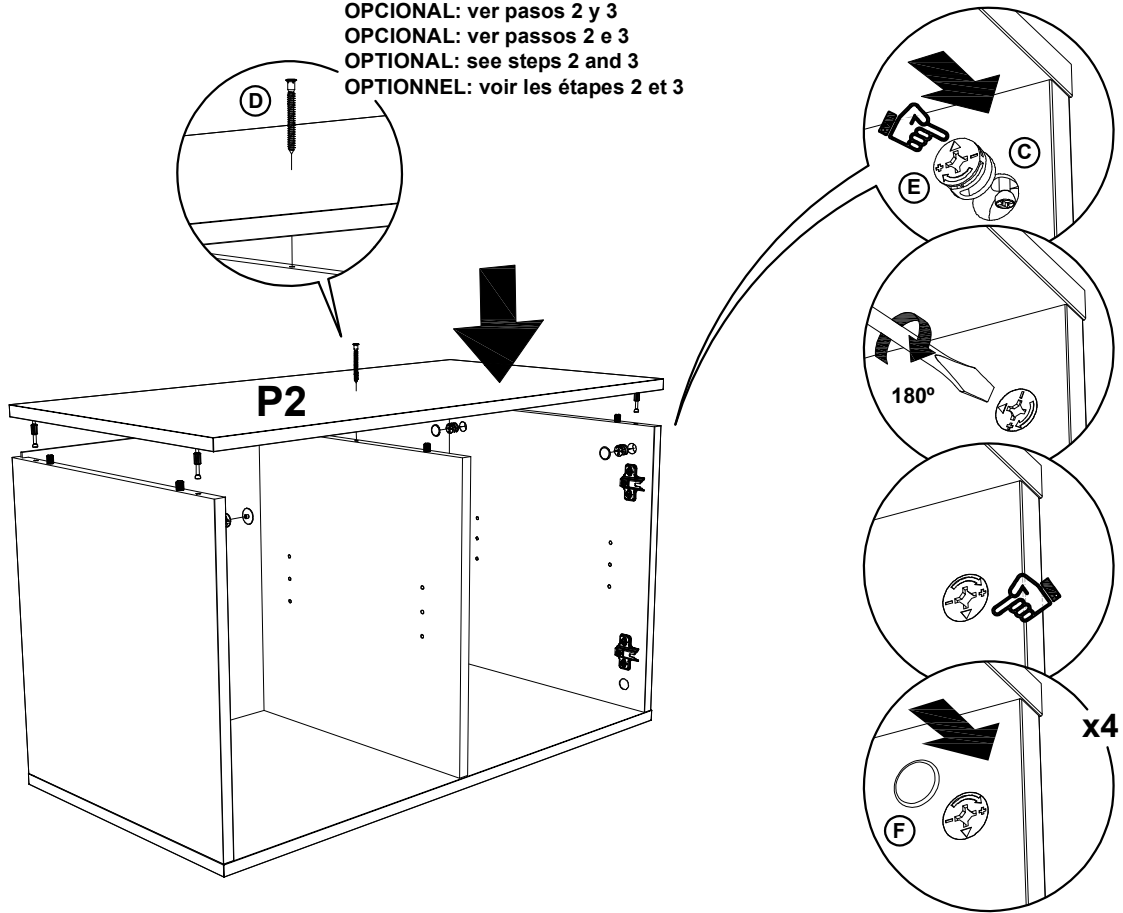

6

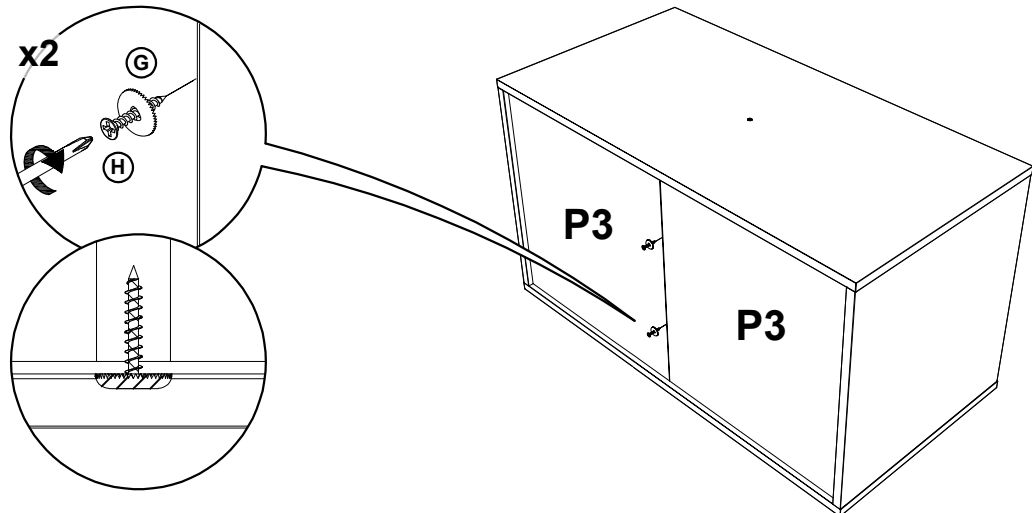
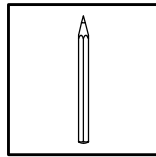
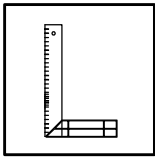
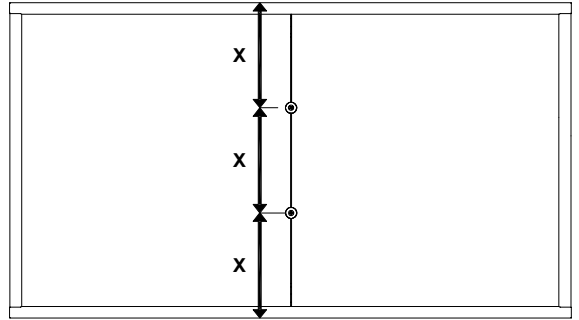
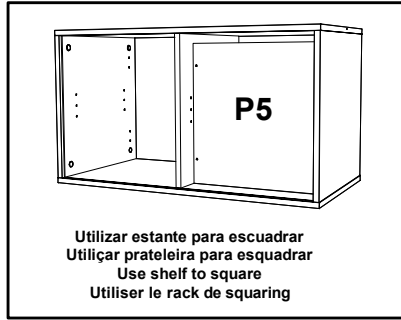
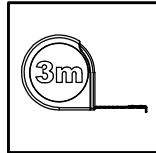
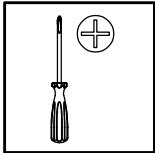

7

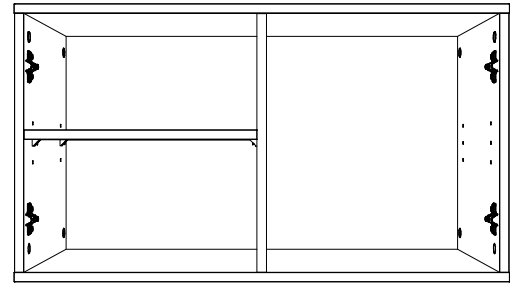
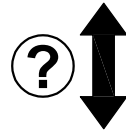
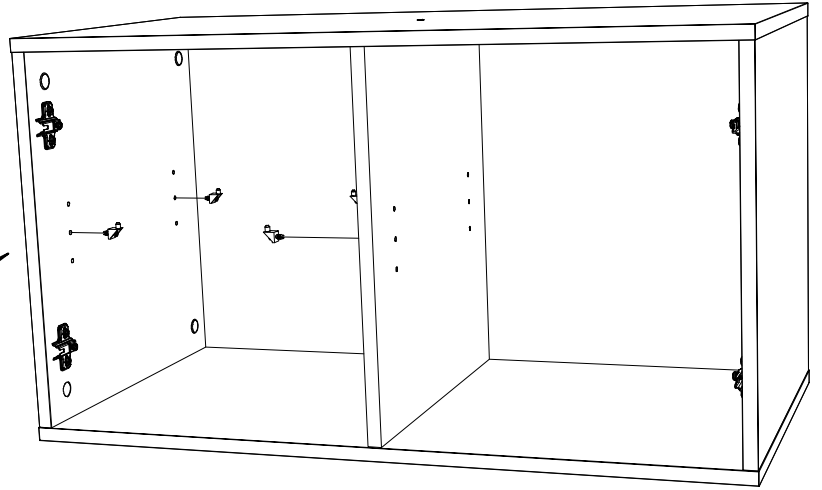
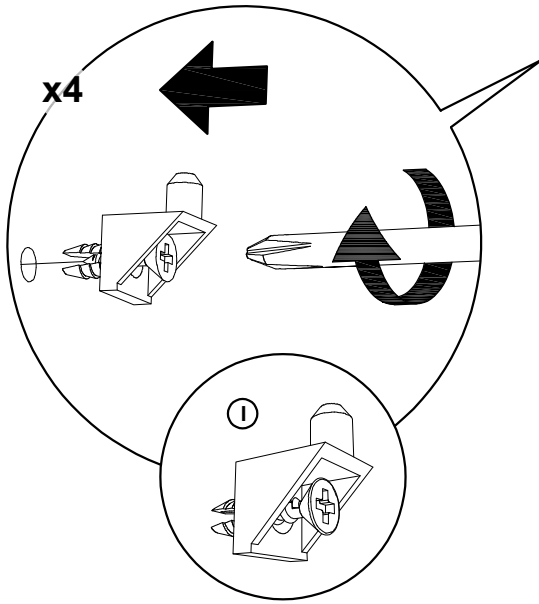
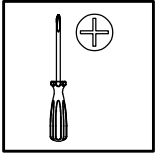

8

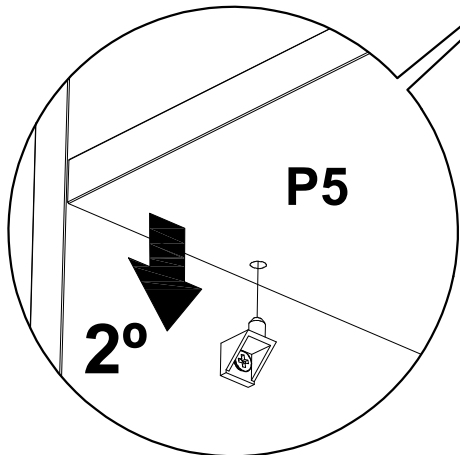
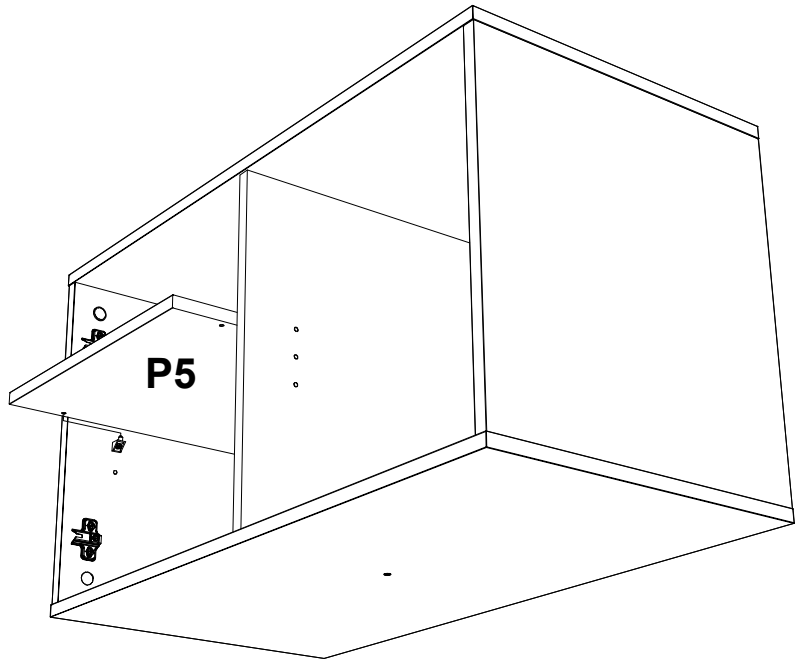
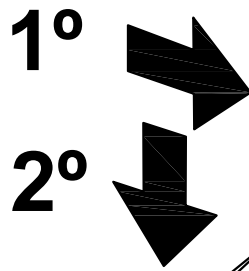

9

x2

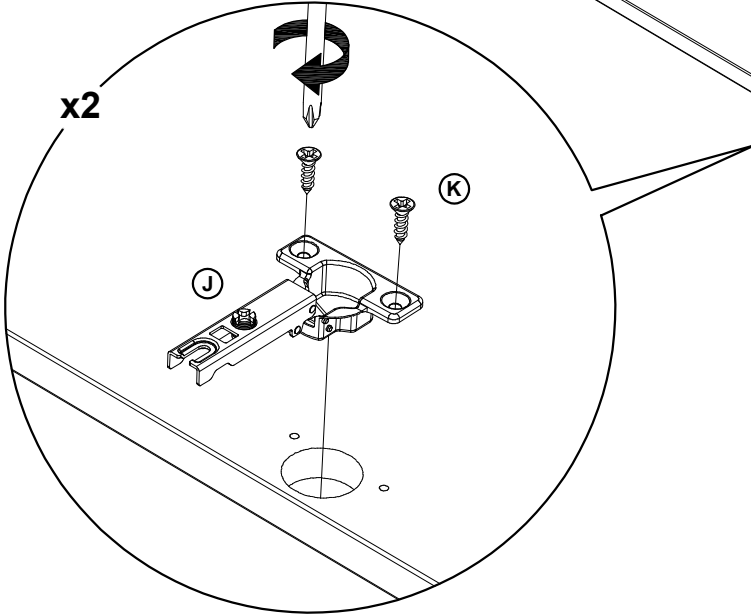
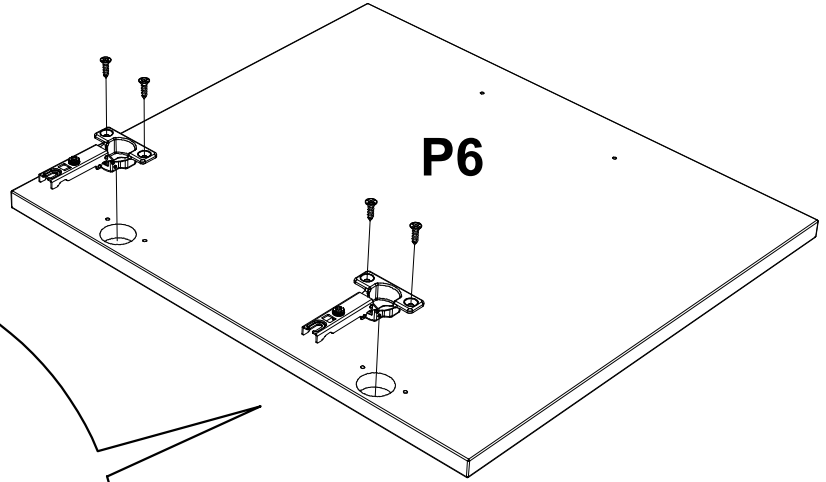
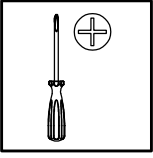

10

x2

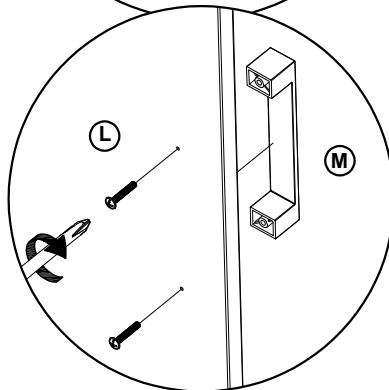
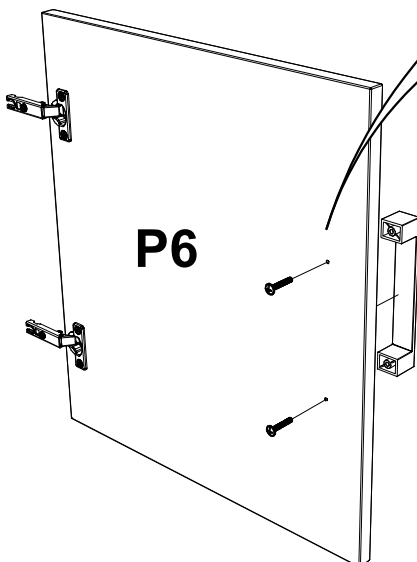
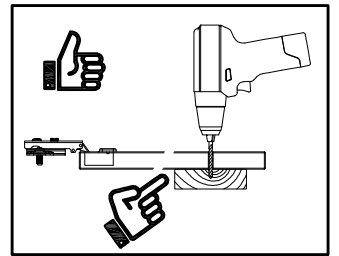
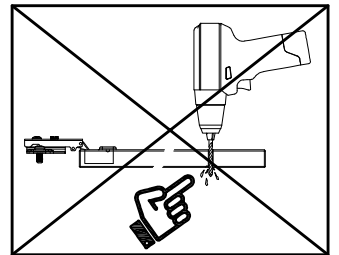
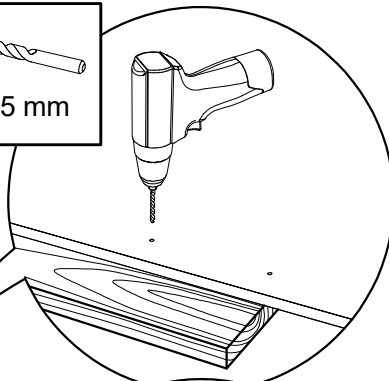
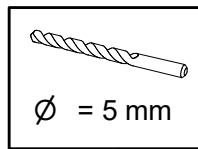
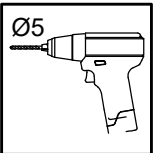
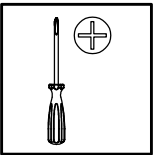

11

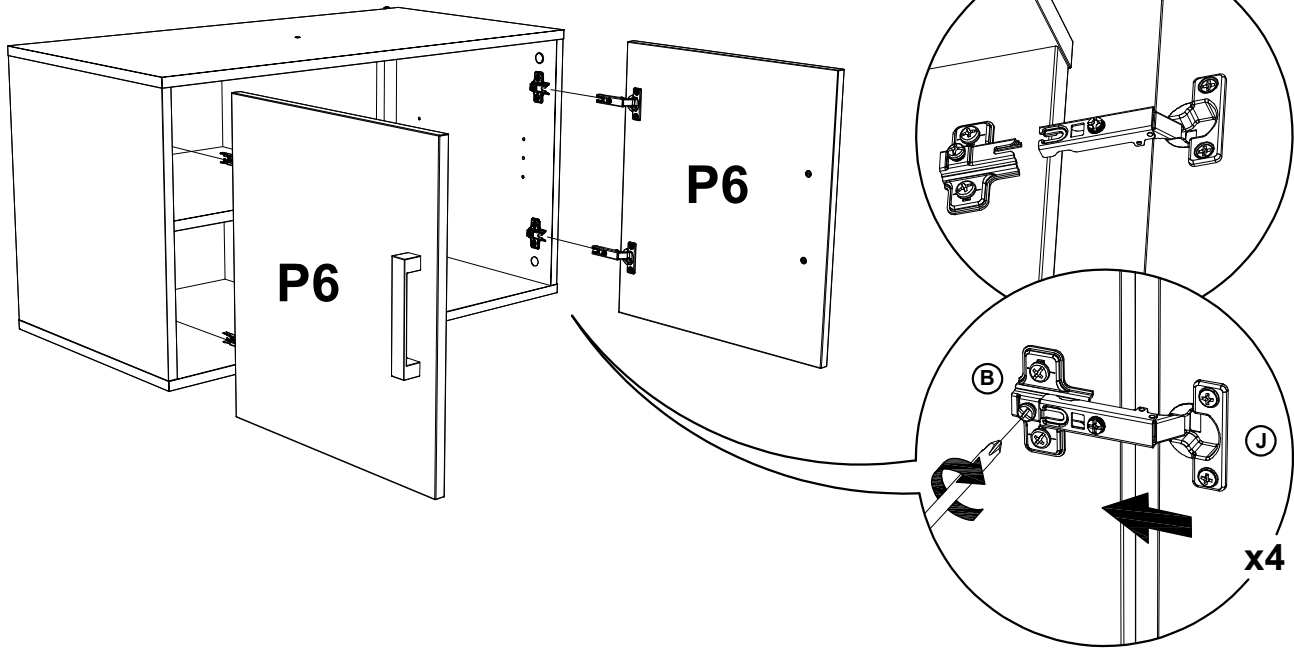
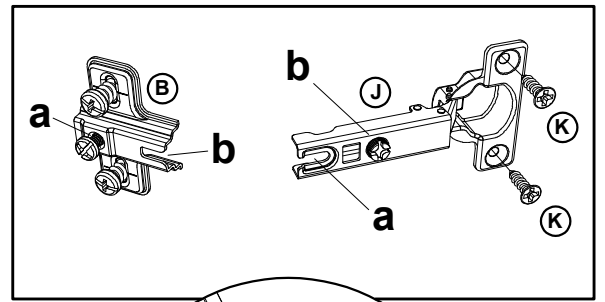
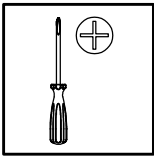

ES) Regulación puertas / PT) Regulação portas / EN) Door adjustment / FR) Réglage de la porte

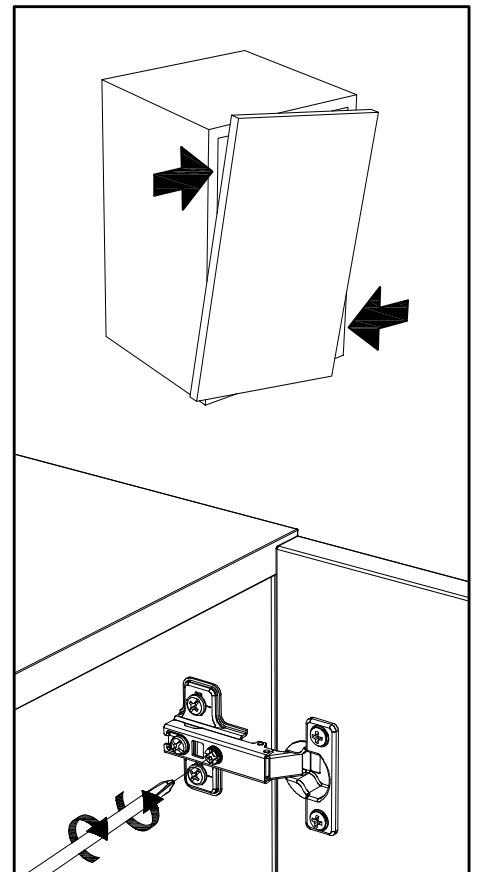
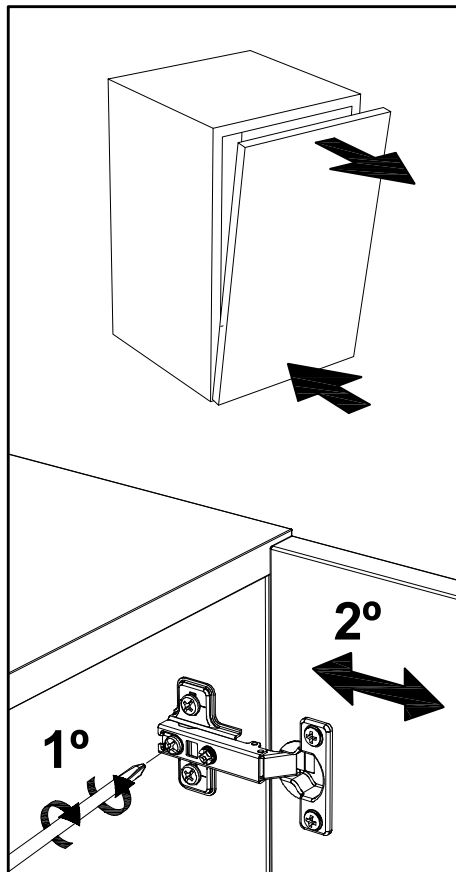
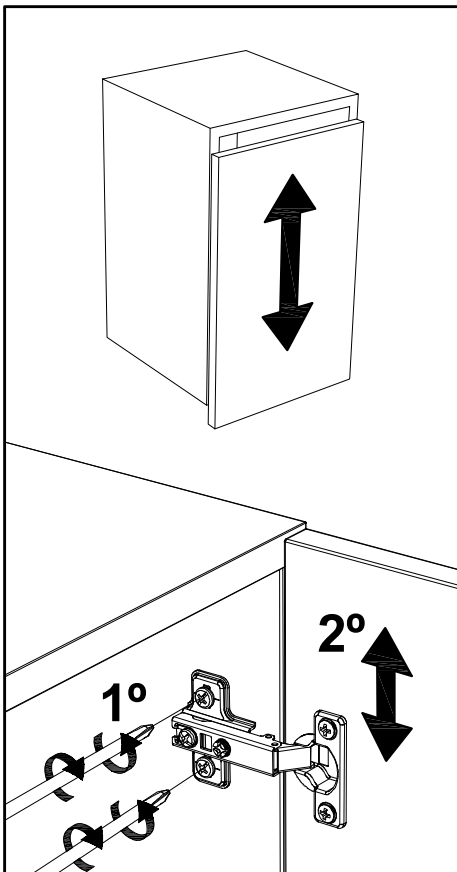

12

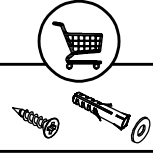
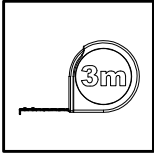
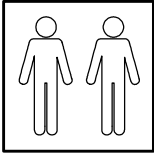

ES) Por motivos de seguridad es necesario fijar a la pared. Tornillos y tacos según tipo de pared (no incluidos)

PT) Por razões de segurança é necessário fixar na parede. Parafusos e tacos de acordo com o tipo de parede (não incluídos)

EN) For safety reasons it is necessary to fix to the wall. Use screws and plugs according to wall type (not included)

FR) Pour des raisons de sécurité, il est nécessaire de fixer au mur. Vis et chevilles selon le type de mur (non inclus)

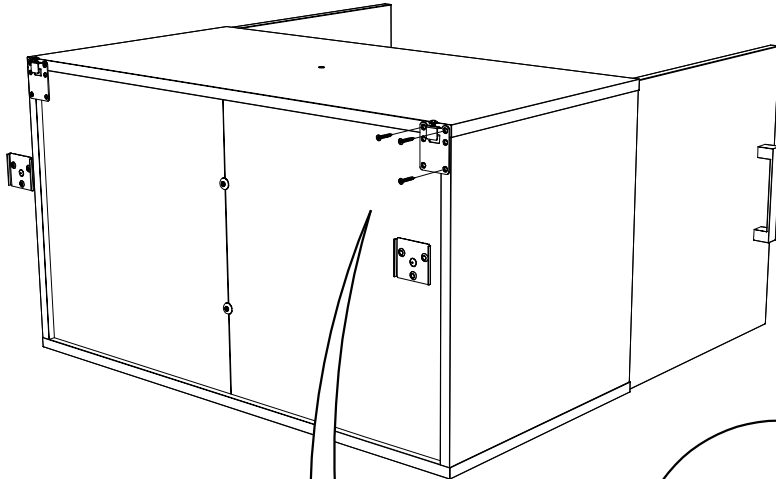

1°

Fijar a mueble
Fixar ao móvel
Attach to furniture
Se fixer aux meubles

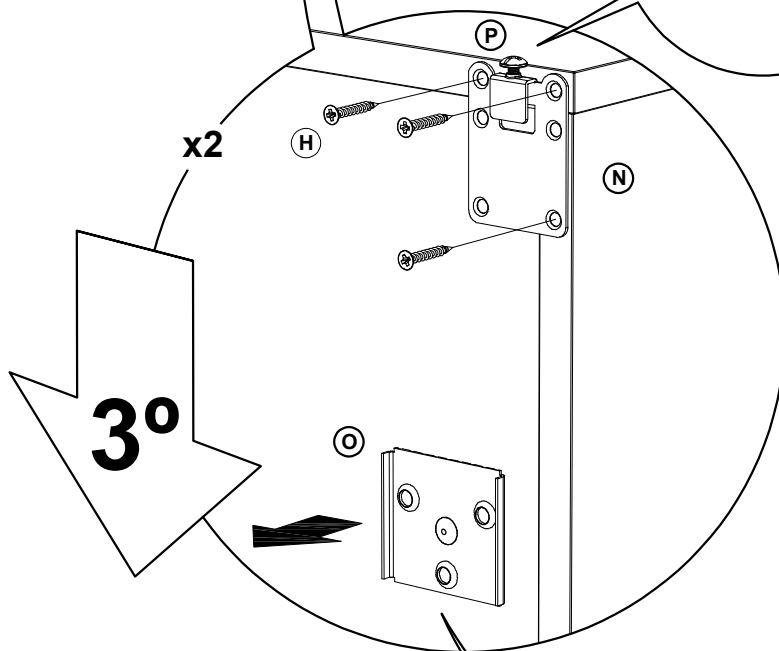
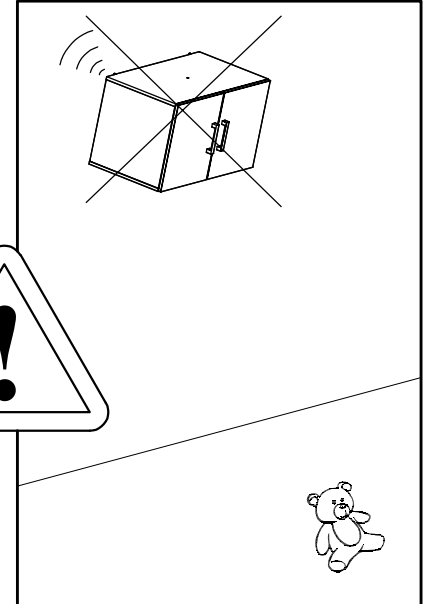

Alinear en vertical
Alinhar verticalmente
Align vertically
Aligner verticalement

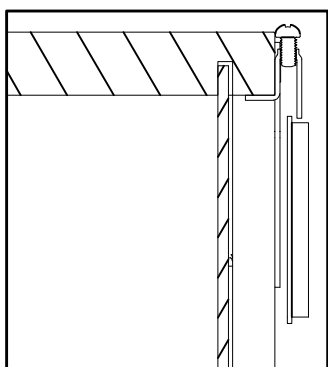
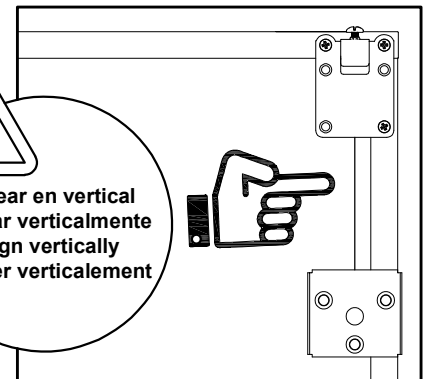

Sección
Secção
Section

Fijar a pared
Fixar à parede
Fix to the wall
Fixer au mur

2°

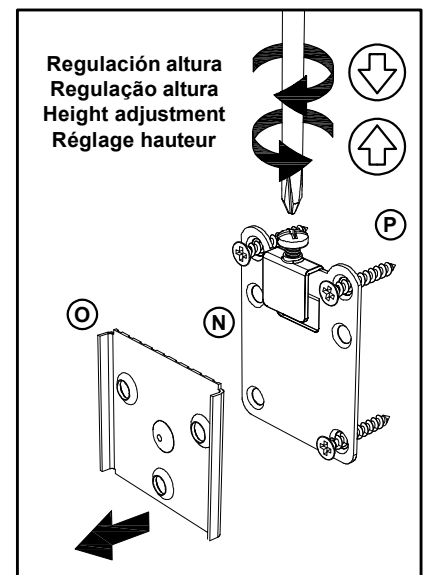

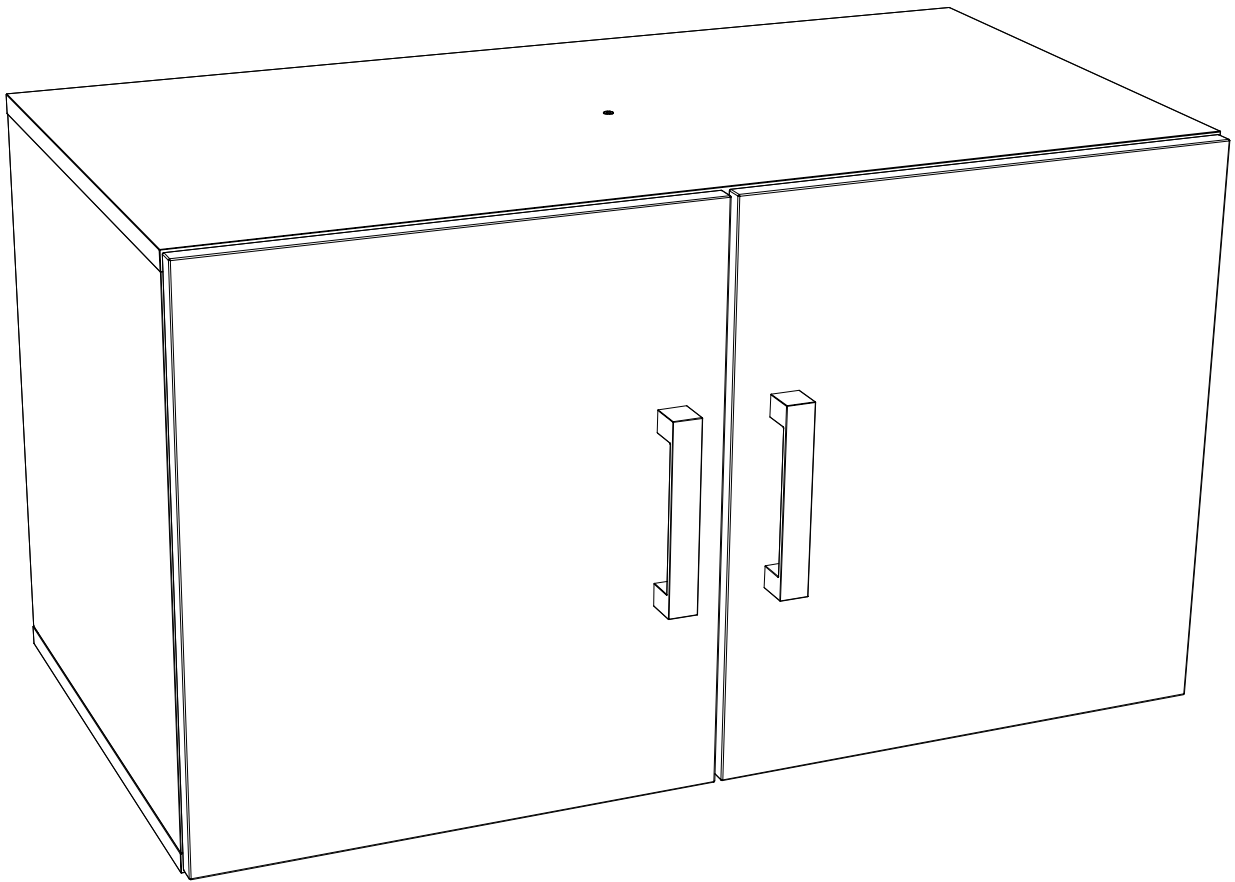

X	00	000	0000
A/B/C	00-99	1-366	24h
N° lote / N° lot / No. batch / N° lot			

ES) Para cualquier consulta post-venta, dirijase al punto de venta con el número de lote situado en la etiqueta del embalaje exterior
PT) Para qualquer consulta pós-venda, contacte o ponto de venda com o número do lote localizado na etiqueta da embalagem exterior
EN) For any aftersales enquiries, please contact the retailer with the batch number located on the outer packaging label
FR) Pour plus de renseignements, merci de contacter le point de vente avec le numéro de lot figurant sur l'étiquette de l'emballage extérieur