

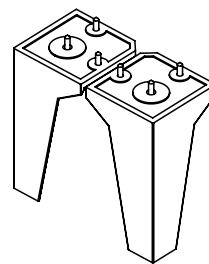

# JNKA

**IT-Istruzioni di montaggio  
colonna 1 anta reversibile**  
**EN-Assembly instructions  
of reversible 1 door column**  
**FR-Notice de montage  
colonne 1 porte réversible**

**86670379**  
**86670380**  
**86670369**  
**86670378**

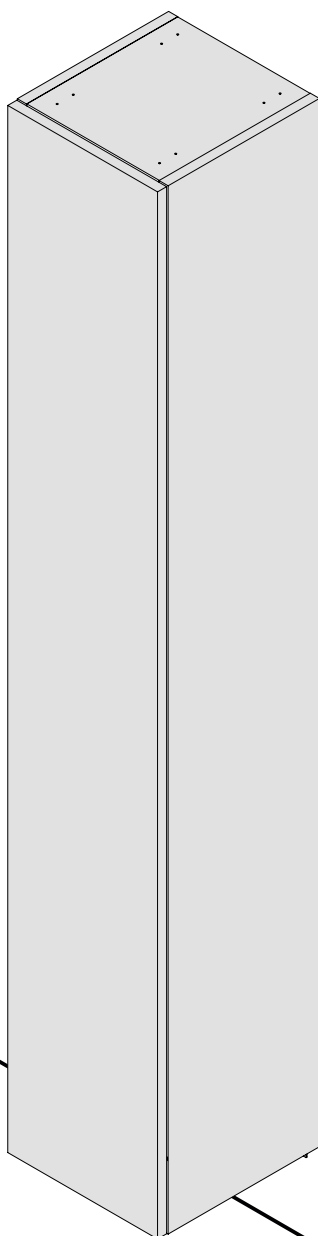

**pedini**  
feets  
pieds  
**86670370**  
opzionale/optional/  
optionnel



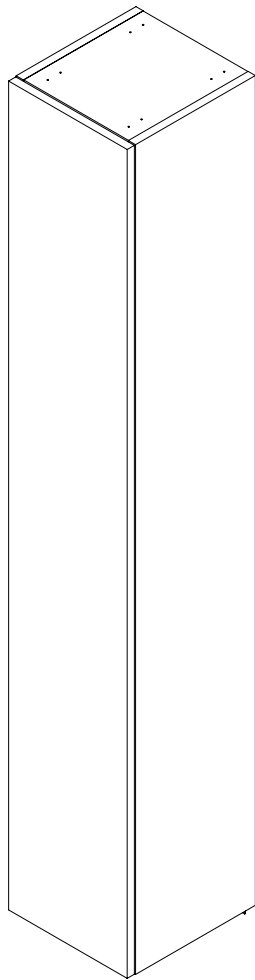

**IT-**Al fine di evitare il ribaltamento del mobile è obbligatorio il fissaggio dello stesso a parete tramite le apposite attaccaglie.

\* Viti e tasselli (non inclusi) devono essere adeguati al tipo di materiale della vostra parete

**EN-**In order to avoid the furniture overturning, you have absolutely fix it to the wall through the appropriate attachments

\* Screws and dowels (not included) must be suitable to the type of material of your wall

**FR-**Pour éviter tout risque de basculement, le meuble doit être absolument fixé au mur à l'aide des supports de fixation fournis

\* Utiliser des vis et chevilles (non fournies) adaptées au type de matériaux de votre mur

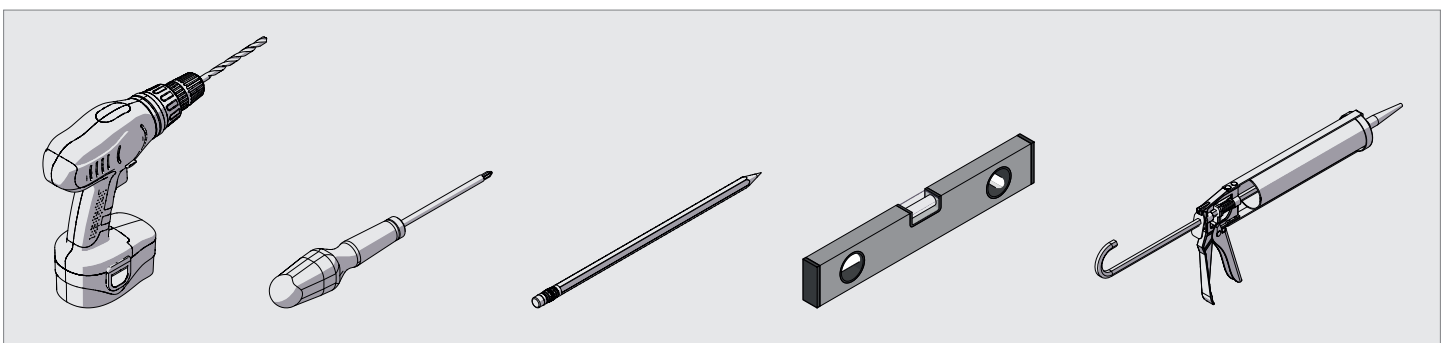

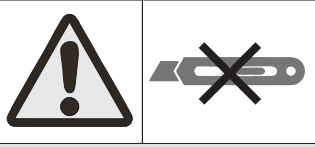

1

IT-Sballaggio arredi  
EN-Unpacking  
FR-Déballage

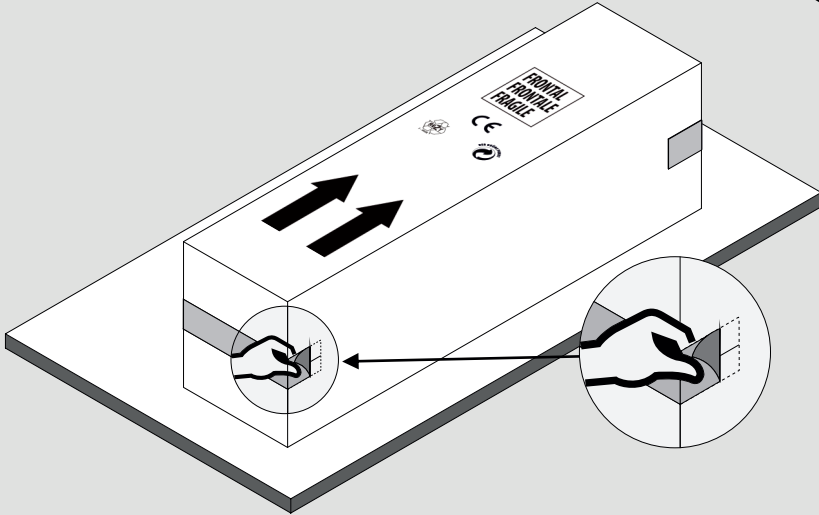

2/3

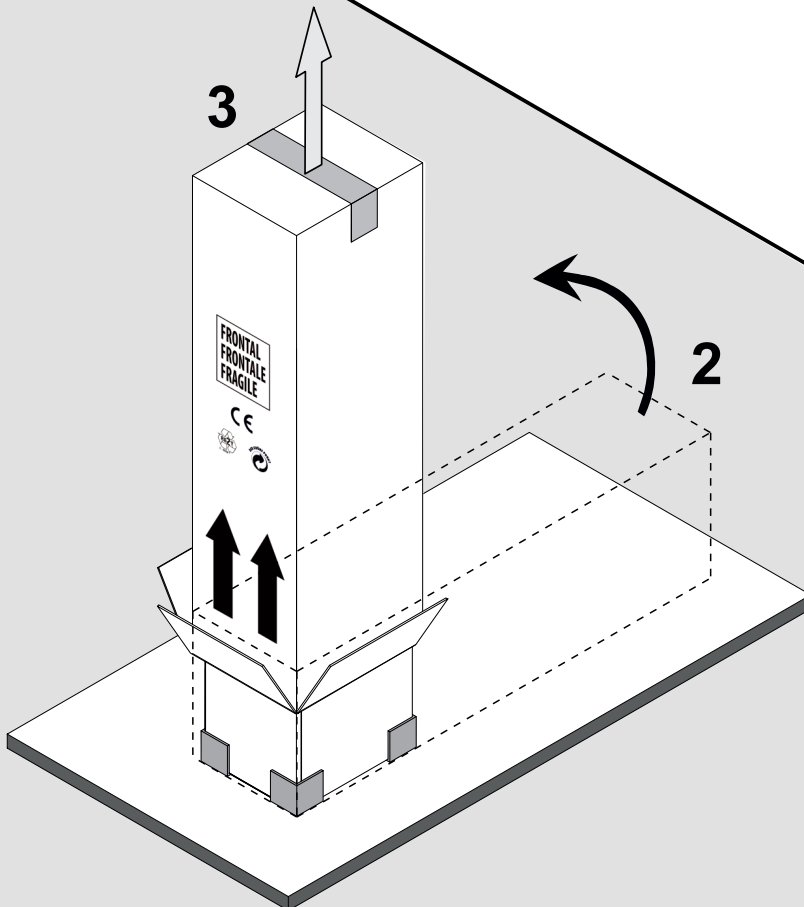

4

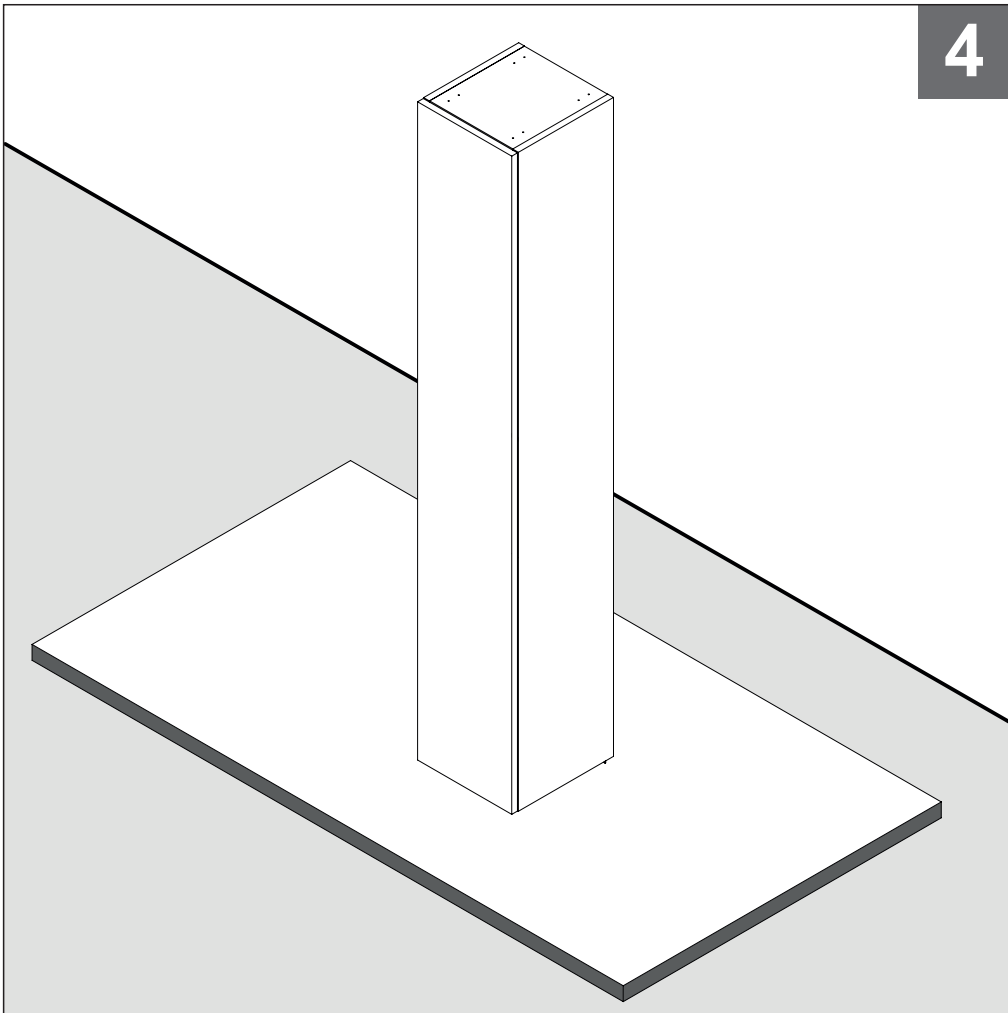

5

  
RECYCLED

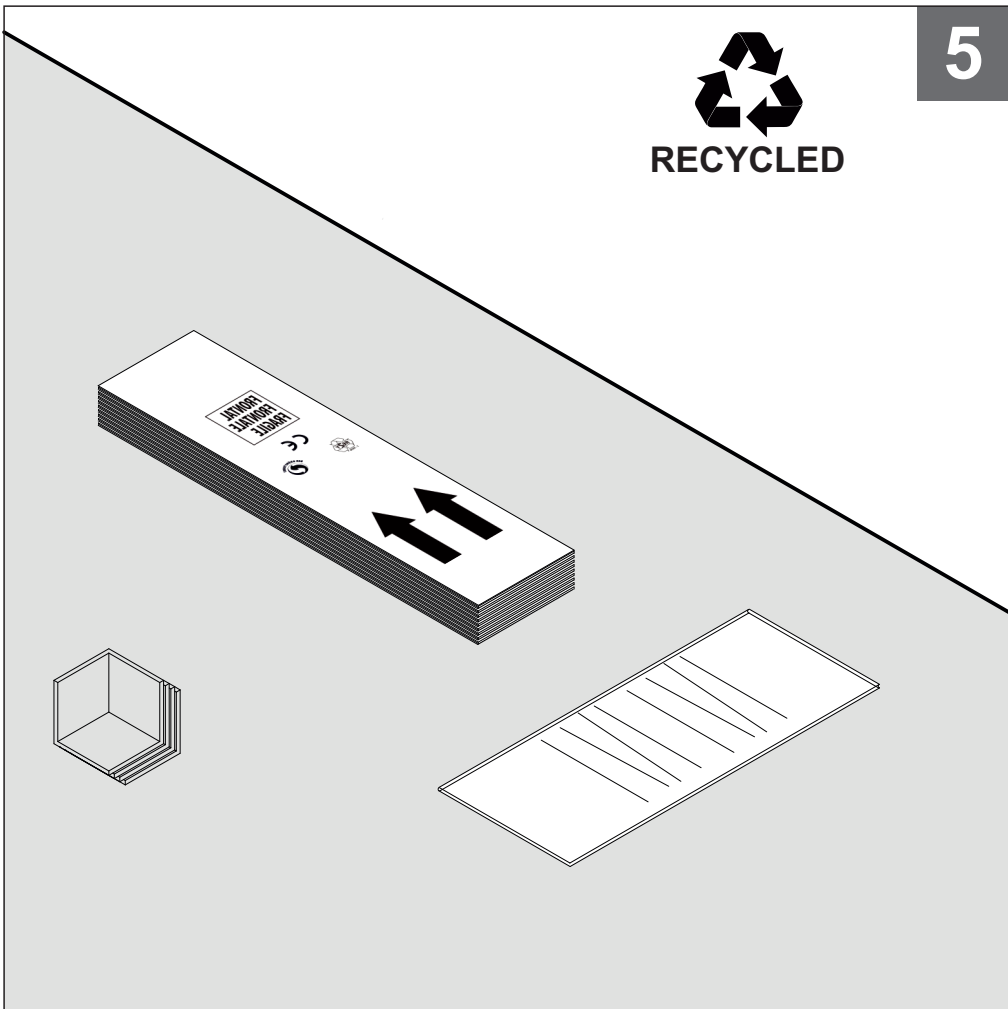

6

**IT-Fissaggio**  
ammortizzatore anta  
**EN-Door damper fixing**  
**FR-Fixation**  
d'amortisseur de porte

---

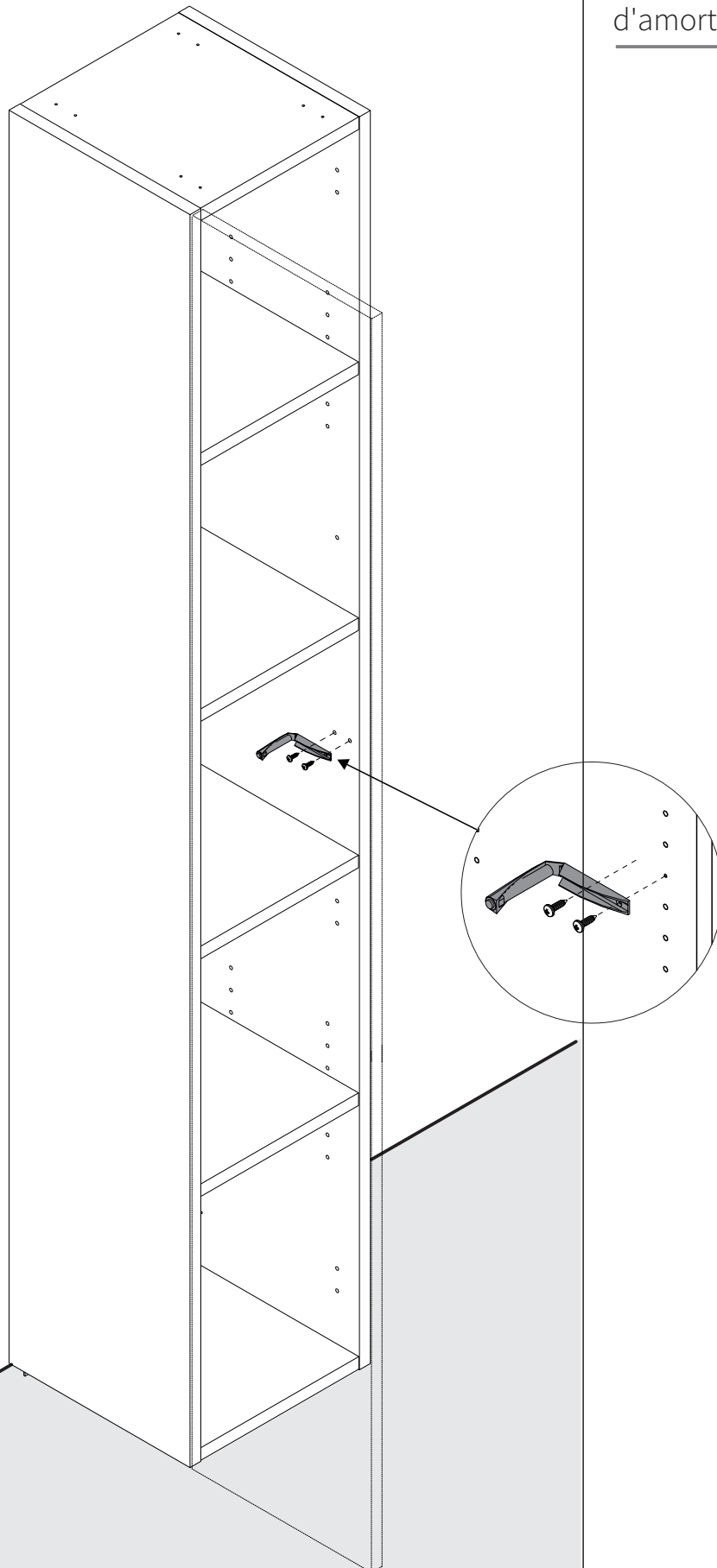

6a

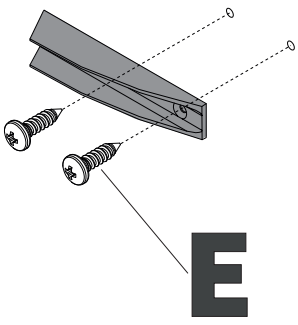

6b

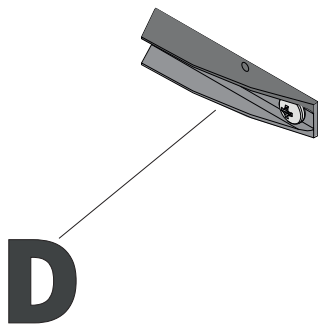

6c

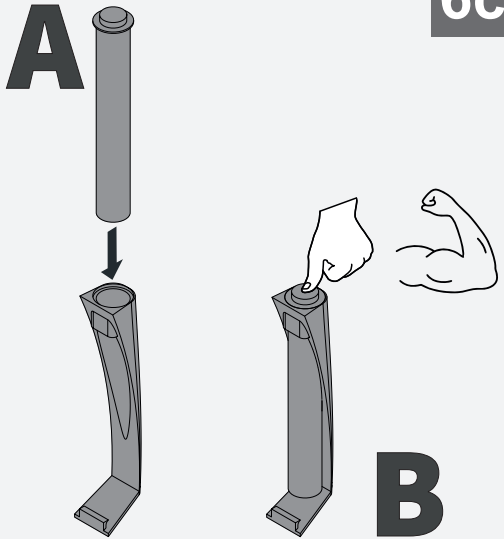

6d

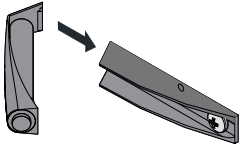

6e

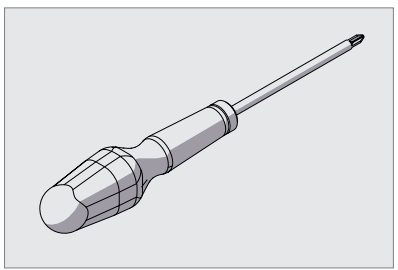
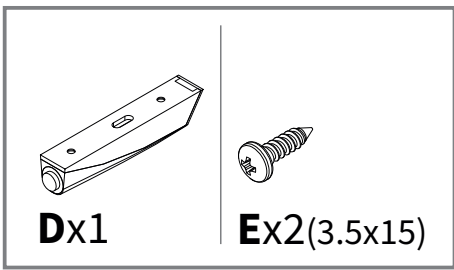
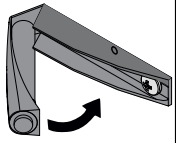

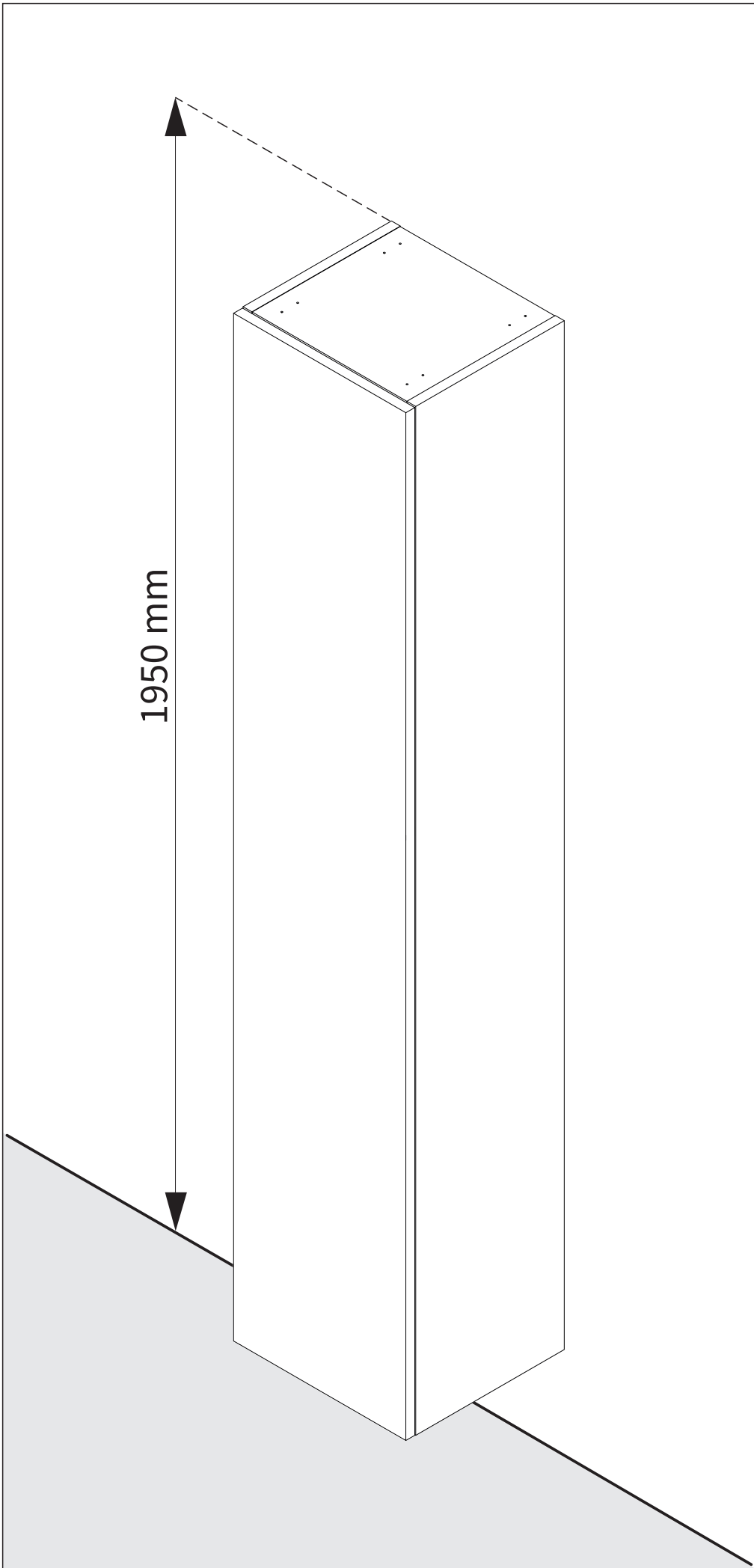

**IT-Quote di fissaggio**  
**altezza consigliata**  
EN-Fixing dimensions  
recommended height  
FR-Dimensions de fixation  
hauteur recommandée

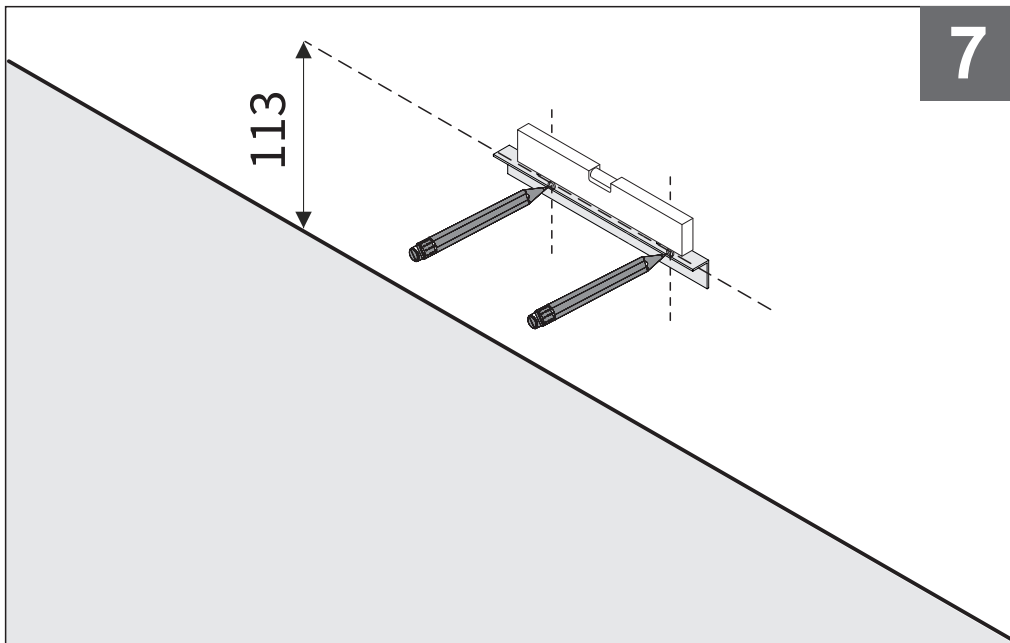

IT-Fissaggio colonna a parete  
 EN-Column fixing  
 FR-Fixation de colonne au mur

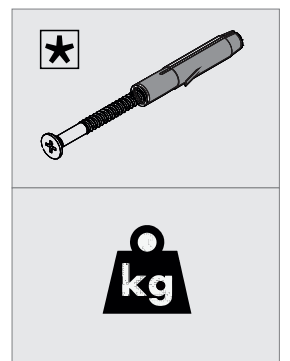
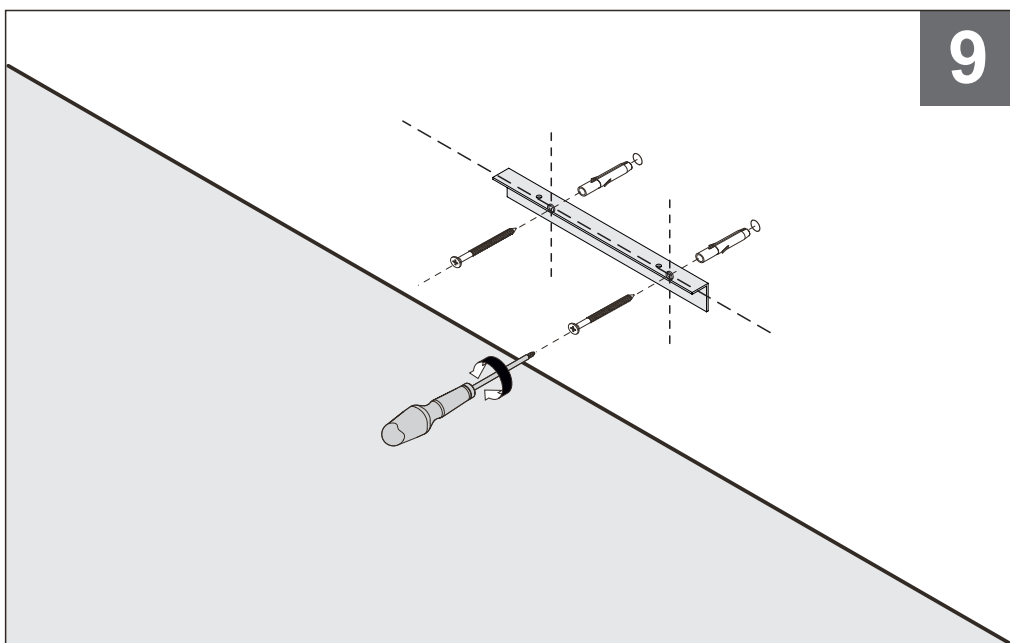
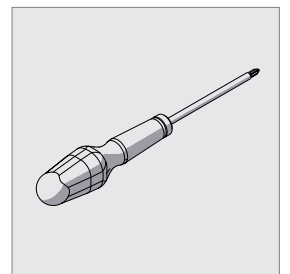
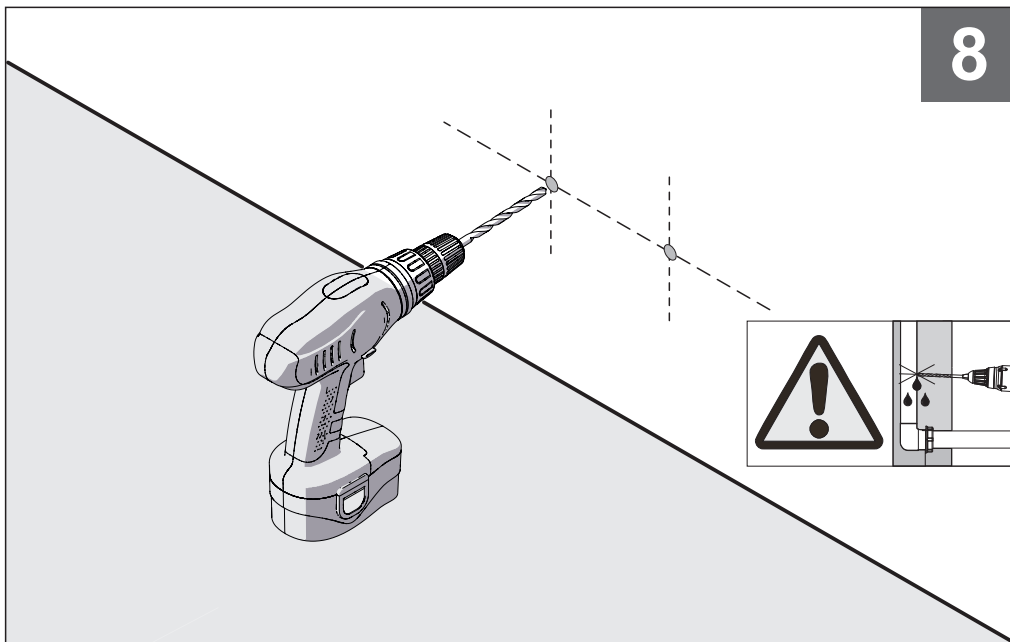
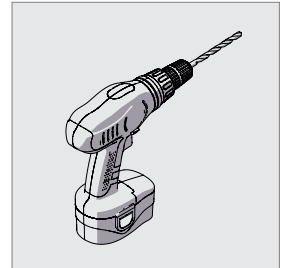

10

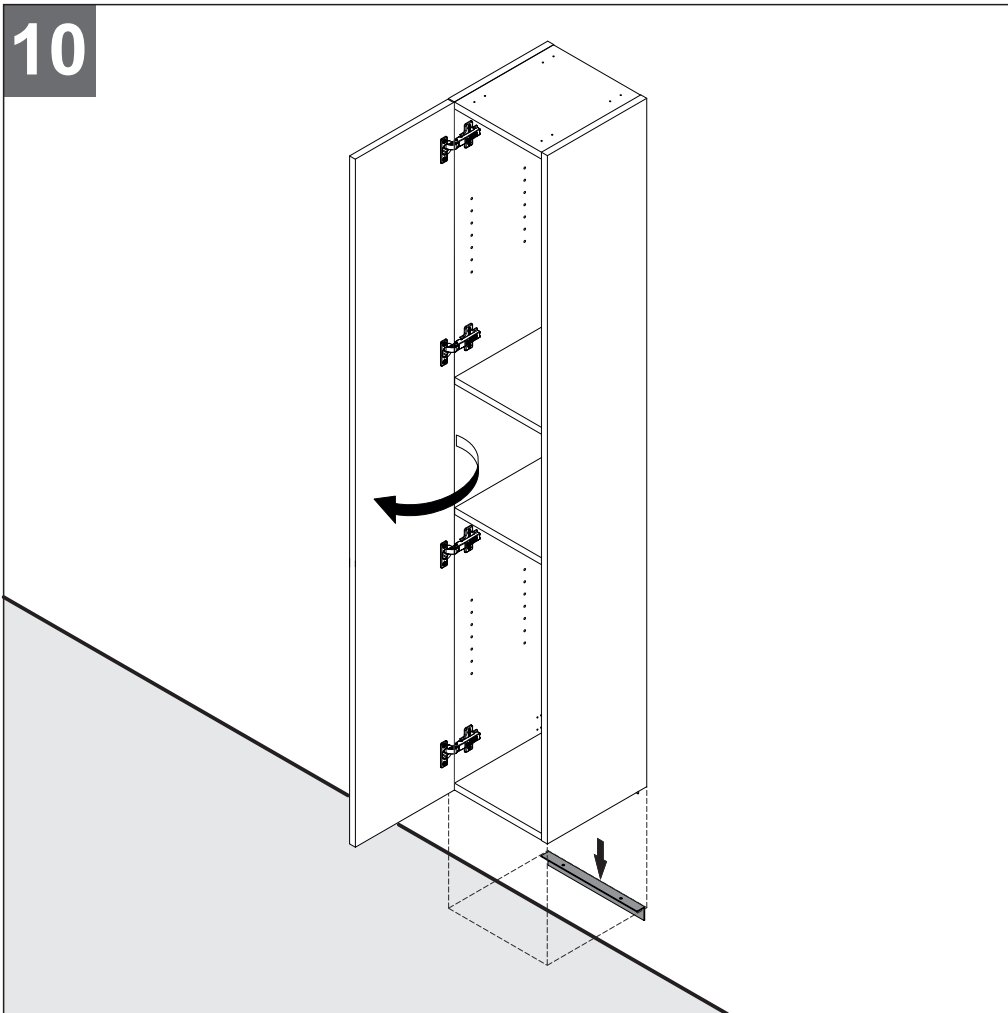

11

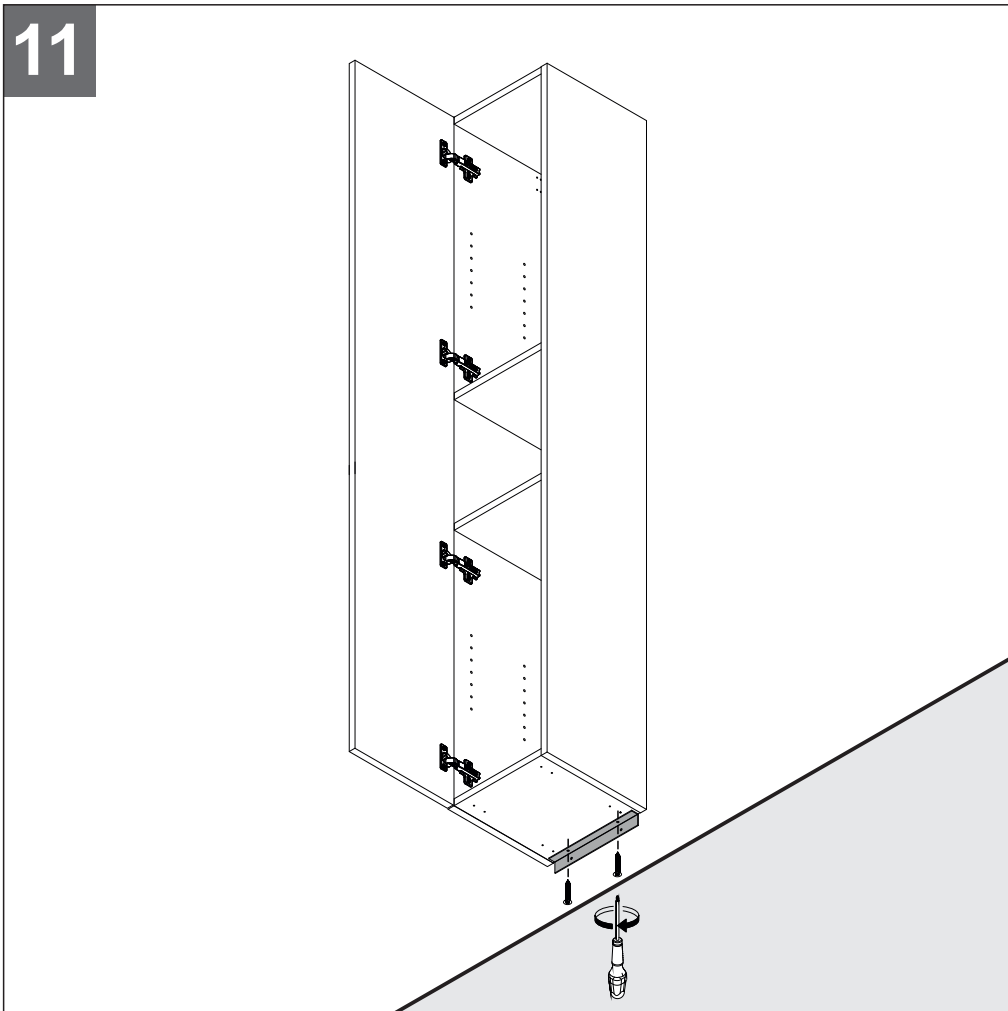

12

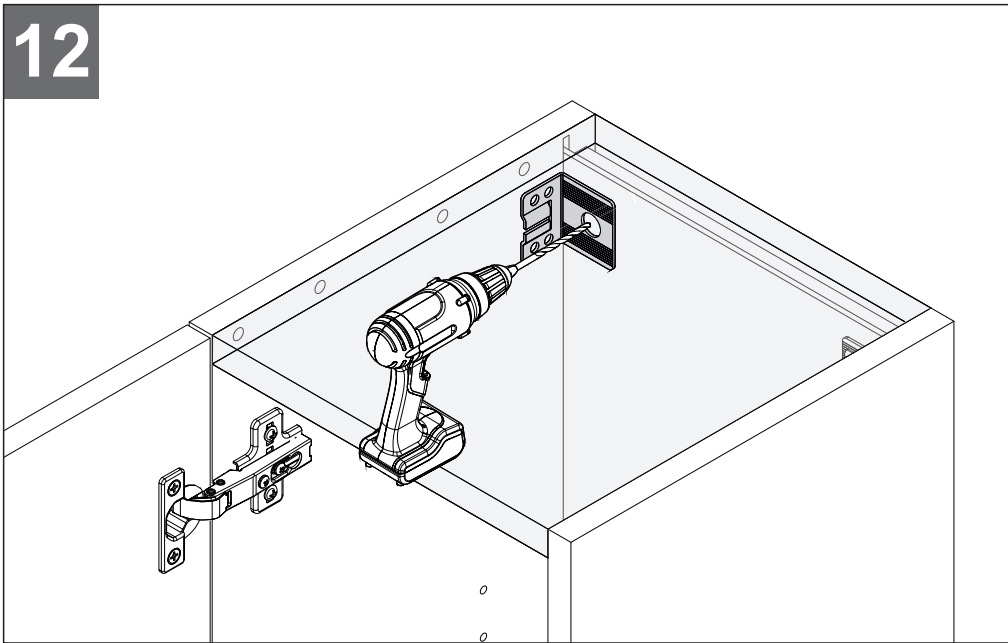

13

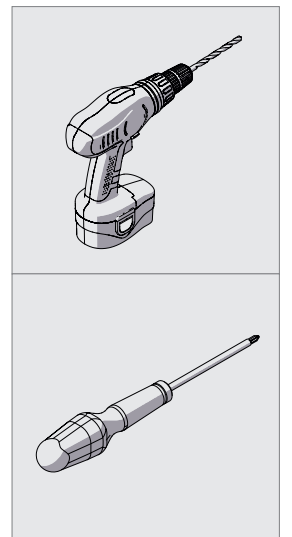
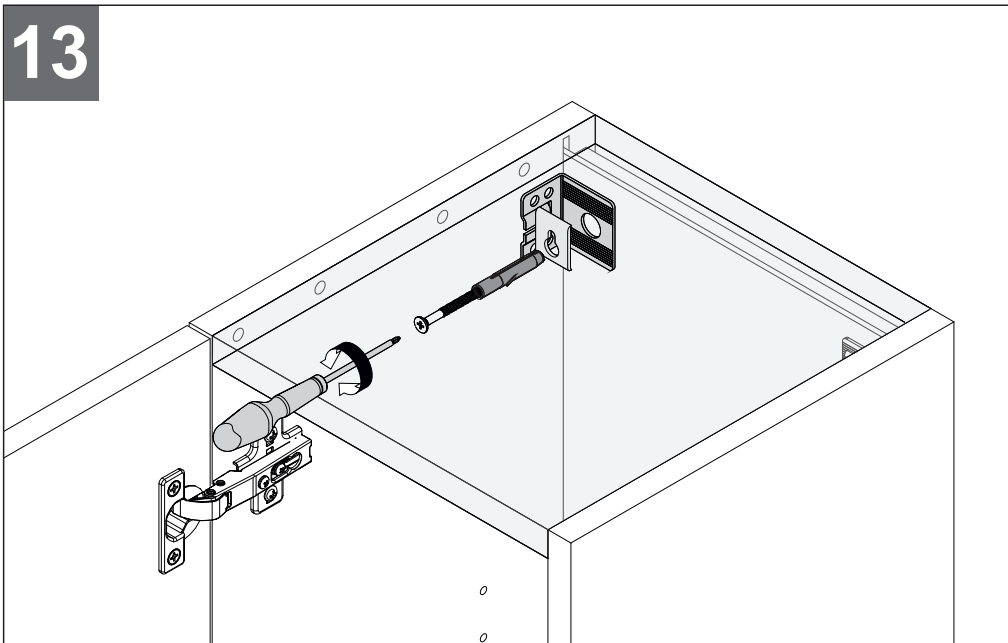

14

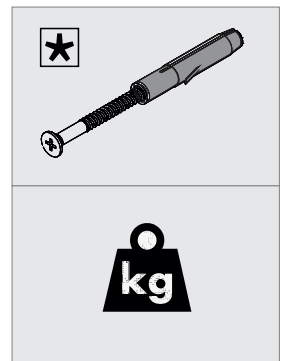
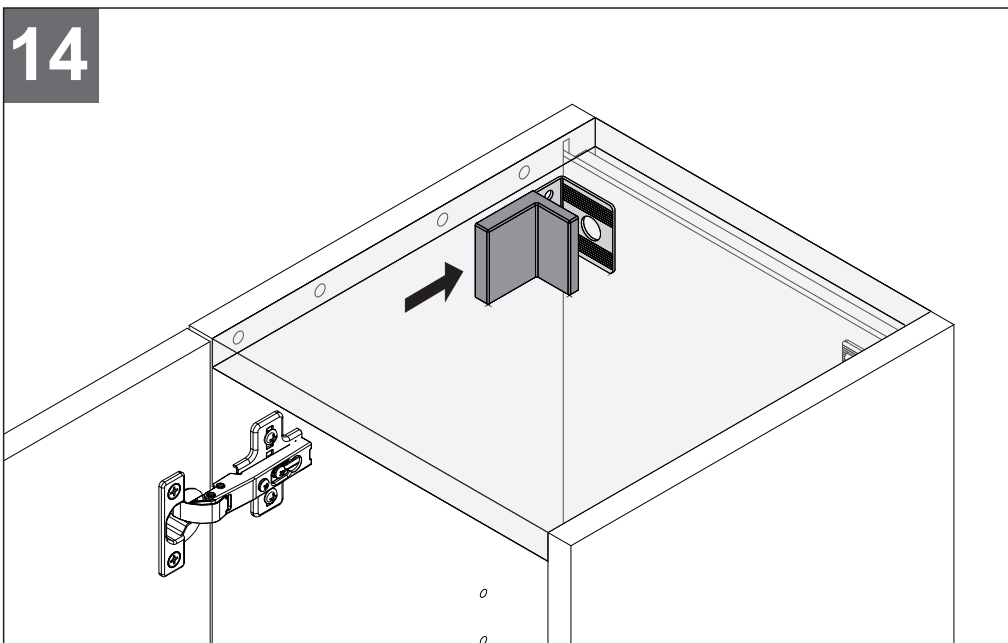

15

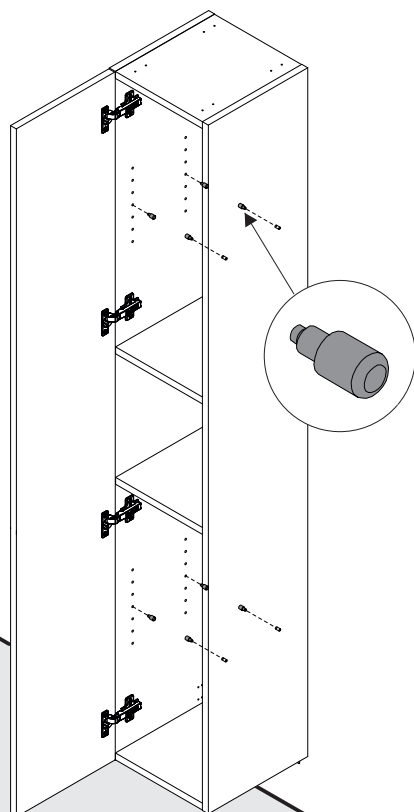

16

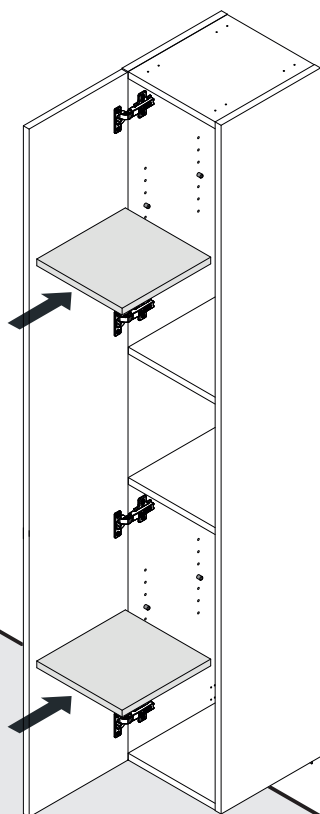

17

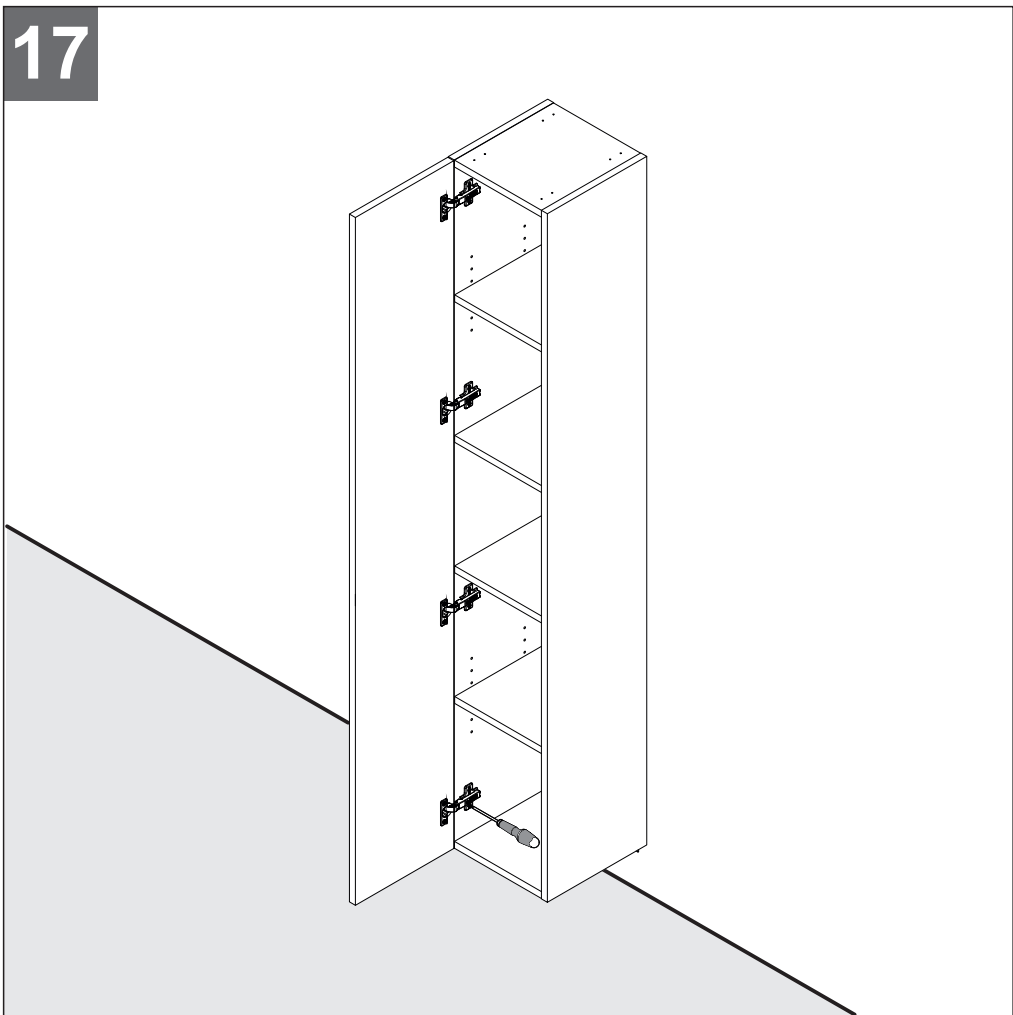

**IT-Regolazione cerniere**  
**EN-Hinges regulation**  
**FR-Réglage des charnières**

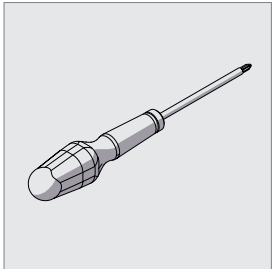

**IT-Regolazione laterale**  
**EN-Lateral adjustment**  
**FR-Réglage latéral**

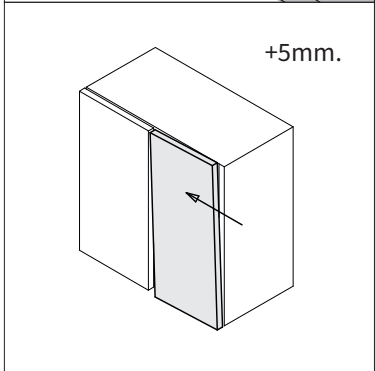
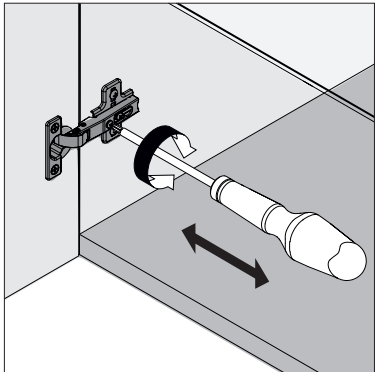

**IT-Regolazione altezza**  
**EN-Vertical adjustment**  
**FR-Réglage en hauteur**

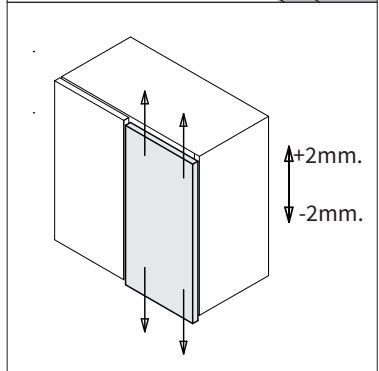
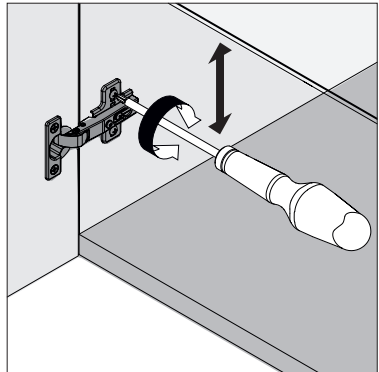

**IT-Regolazione dell'inclinazione**  
**EN-Inclination adjustment**  
**FR-Réglage de l'inclinaison**

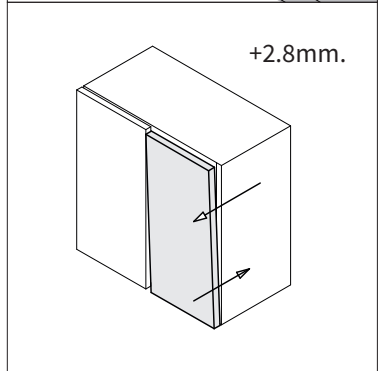
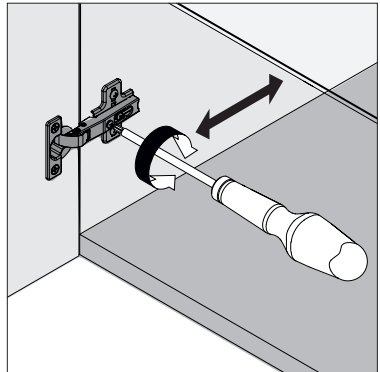

18

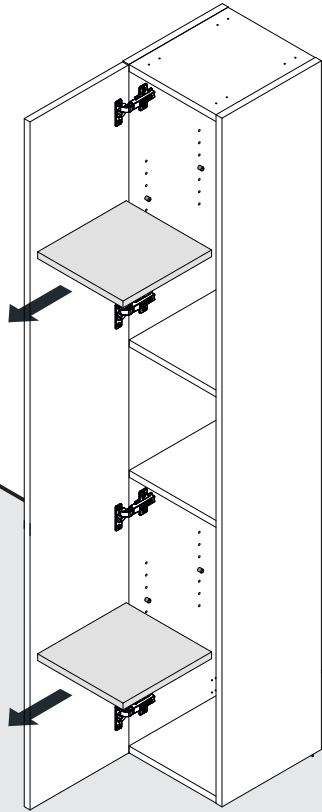

IT-Reversibilità colonna  
EN-Column reversibility  
FR-Réversibilité de colonne

---

19

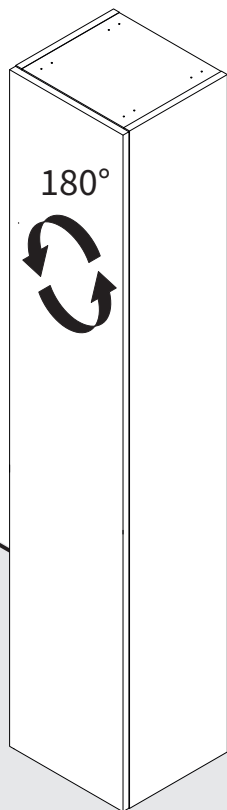

20

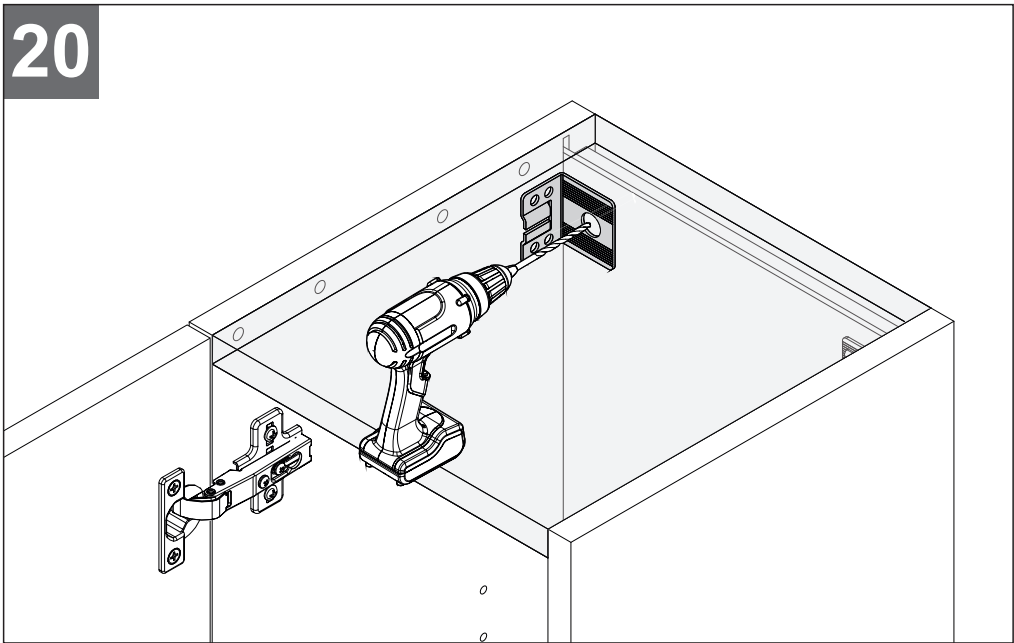

IT-Fissaggio colonna a parete  
EN-Column fixing  
FR-Fixation de colonne au mur

21

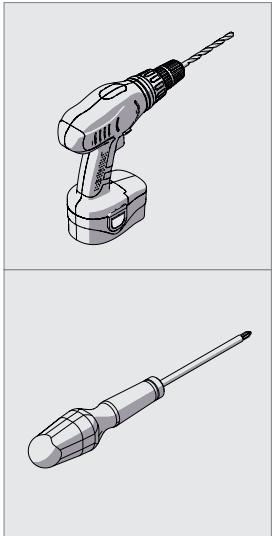
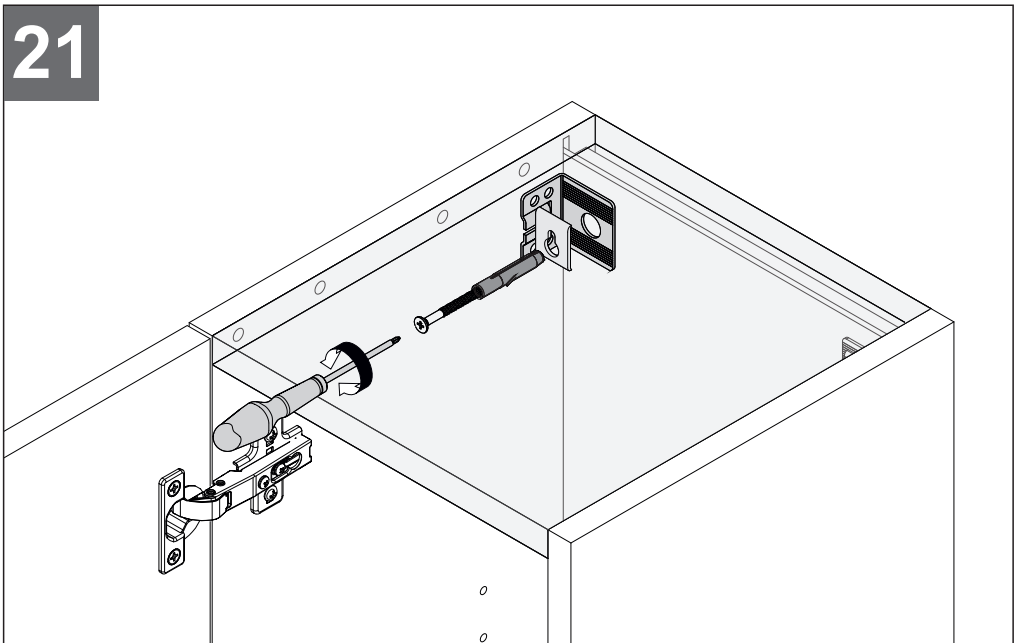

22

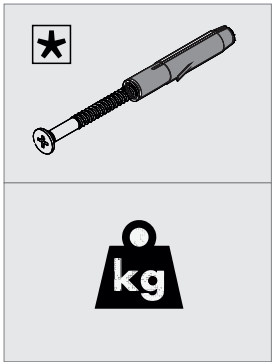
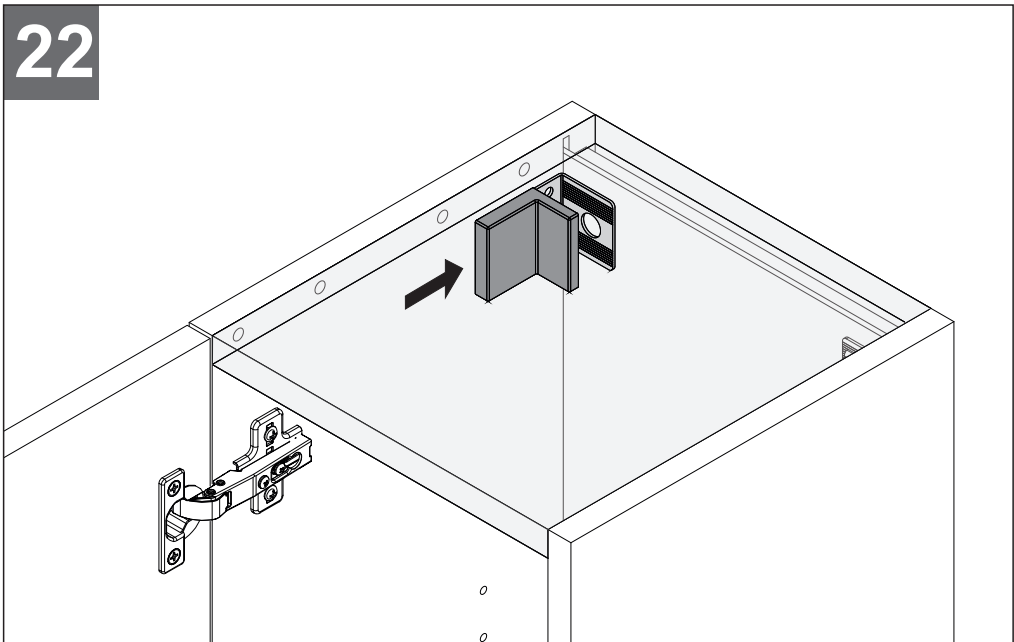

24

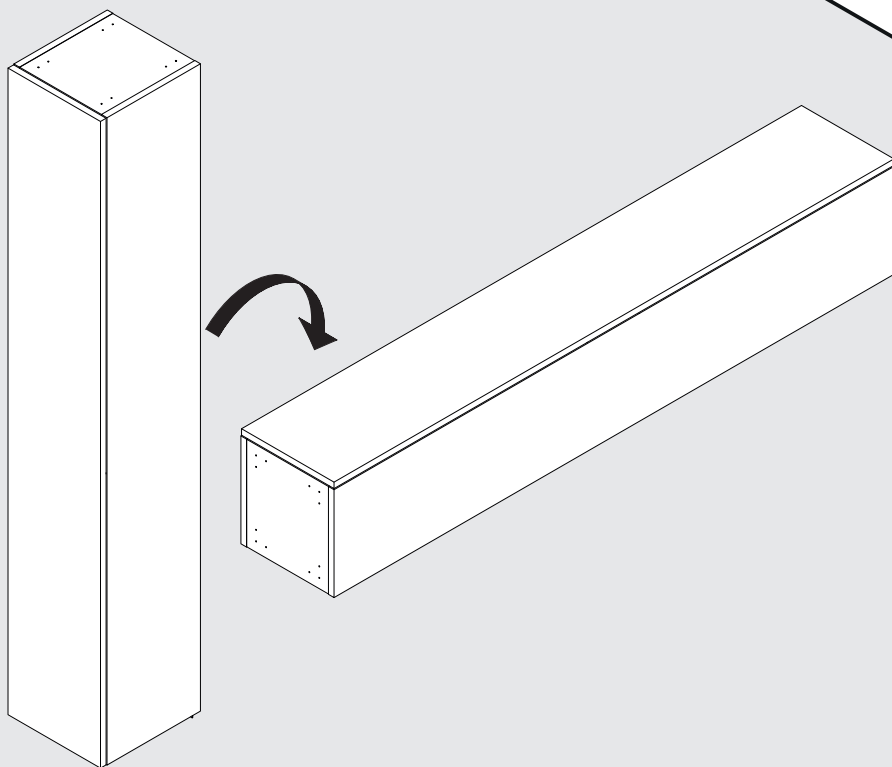

IT-Fissaggio piedini (opzionale)  
EN-Fixing feet (optional)  
FR-Fixation des pieds (en option)

25

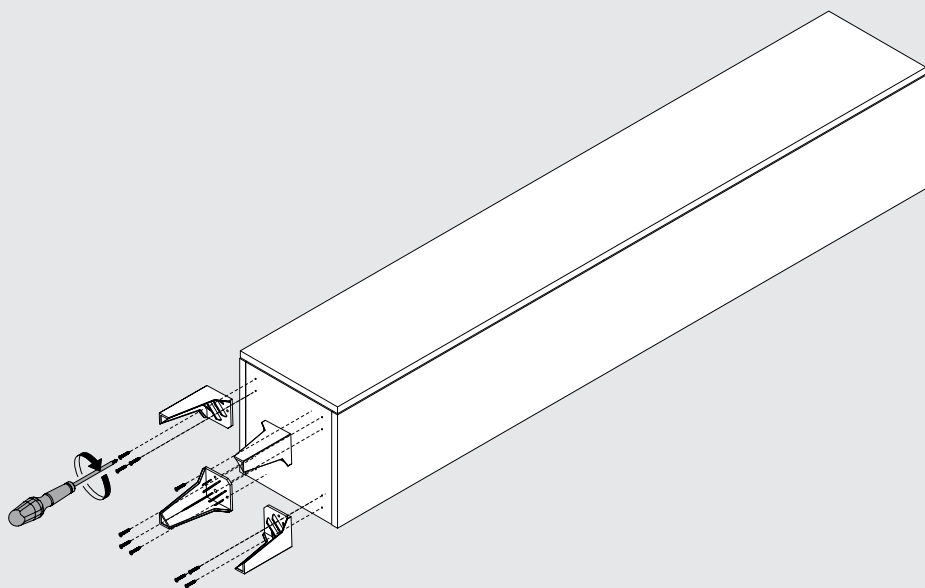

## **IT-Pulizia e manutenzione**

**EN-Cleaning and maintenance**

**FR-Nettoyage et entretien**

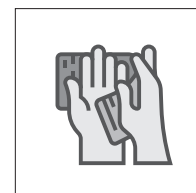
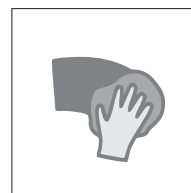

**IT-Per la pulizia utilizzare esclusivamente detersivi al sapone e asciugare con un panno morbido. Non utilizzare detersivi abrasivi, corrosivi o contenenti agenti chimici, alcool, acidi o solventi. Evitare anche l'impiego di spugne abrasive, pagliette metalliche etc. che danneggerebbero irrimediabilmente le superfici del prodotto, compromettendone la lucentezza o la satinatura. In presenza di acque calcaree o aggressive asciugare dopo l'uso poiché i depositi potrebbero intaccare la superficie del prodotto.**

**EVITARE CHE L'ACQUA SCENDA E RISTAGNI SUL MOBILE; NEL CASO QUESTO ACCADA, ASCIUGARLO TEMPESTIVAMENTE.**

**EN-For cleaning use only soap detergents and dry with a soft cloth.**

Do not use abrasive, corrosive or chemical agents, alcohol, acids or solvents.

Also avoid the use of abrasive sponges, metal scourers etc. that would irreparably damage the surfaces of the product, compromising the gloss or the satin finish.

In the presence of calcareous or aggressive waters, dry after use as deposits may affect the surface of the product.

**DO NOT LET THE WATER COME DOWN AND STAND ON THE CABINET; IF THIS HAPPENS, DRY IT PROMPTLY.**

**FR-Pour le nettoyage utiliser seulement des détergents à base de savon et secher avec un chiffon doux. Ne pas utiliser de détergents abrasifs, corrosifs ou à base de produits chimiques, alcool, acides ou solvants.**

Eviter aussi l'utilisation d'éponges abrasives, de produits à récurer etc.

qui endommageraient de façon permanente les surfaces du produit, en compromettant la finition brillante ou satinée.

En présence d'eaux calcaires ou agressives, secher après l'utilisation car les dépôts pourraient affecter la surface du produit.

**EMPÊCHER L'EAU DE DESCENDRE ET DE STAGNER SUR LE MEUBLE ; SI CELA SE PRODUIT, SÉCHEZ-LE RAPIDEMENT.**

**PRODOTTO IN ITALIA**

**MADE IN ITALY**

**FABRIQUÉ EN ITALIE**