



JNKA

IT-Istruzioni di montaggio
colonna 1 anta reversibile

P.66

EN-Assembly instructions
of reversible 1 door column

D.66

FR-Notice de montage
colonne 1 porte **D.66**

86795134

86670401

86795118

86670402

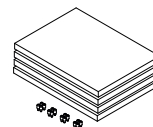

set 4 mensole L.31.3-P.23
per colonna P.46
set of 4 shelves L.31.3-P.23
for column P.46
set de 4 étagères L.31.3-P.23
pour colonne P.46

86795107
opzionale/optional/
optionnel

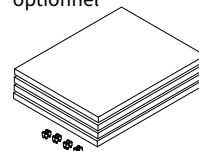

set 4 mensole L.31.3-P.40
per colonna P.46/66
set of 4 shelves L.31.3-P.40
for column P.46/66
set de 4 étagères L.31.3-P.40
pour colonne P.46/66

86795108
opzionale/optional/
optionnel

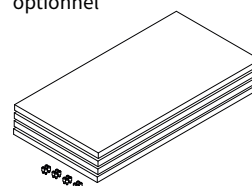

set 4 mensole L.31.3-P.60.5
per colonna P.66
set of 4 shelves L.31.3-P.60.5
for column P.66
set de 4 étagères L.31.3-P.60.5
pour colonne P.66

86795109
opzionale/optional/
optionnel



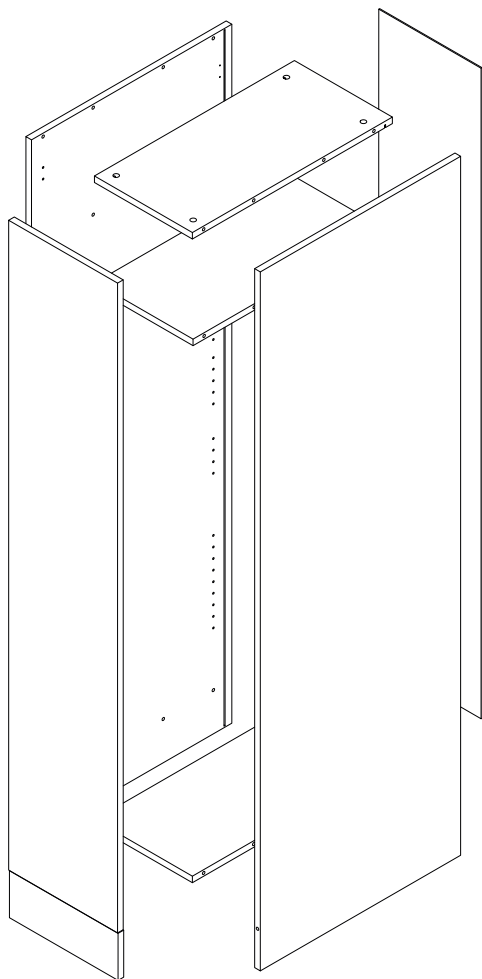

IT-Al fine di evitare il ribaltamento del mobile è obbligatorio il fissaggio dello stesso a parete tramite le apposite attaccaglie.

* Viti e tasselli (non inclusi) devono essere adeguati al tipo di materiale della vostra parete
EN-In order to avoid the furniture overturning, you have absolutely fix it to the wall through the appropriate attachments

* Screws and dowels (not included) must be suitable to the type of material of your wall
FR-Pour éviter tout risque de basculement, le meuble doit être absolument fixé au mur à l'aide des supports de fixation fournis

* Utiliser des vis et chevilles (non fournies) adaptées au type de matériaux de votre mur

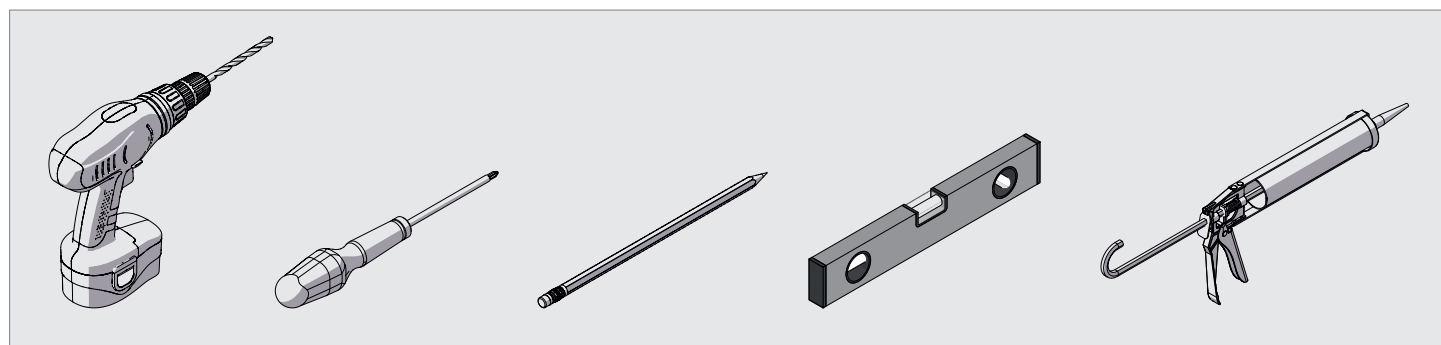
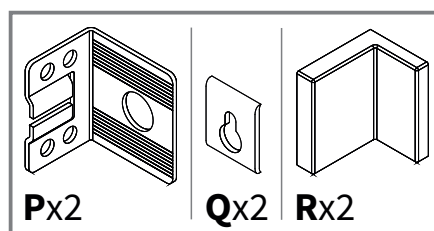
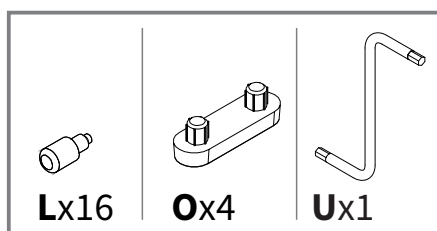
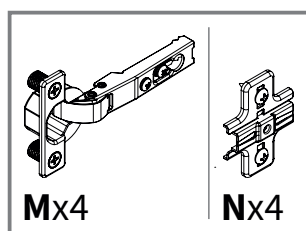
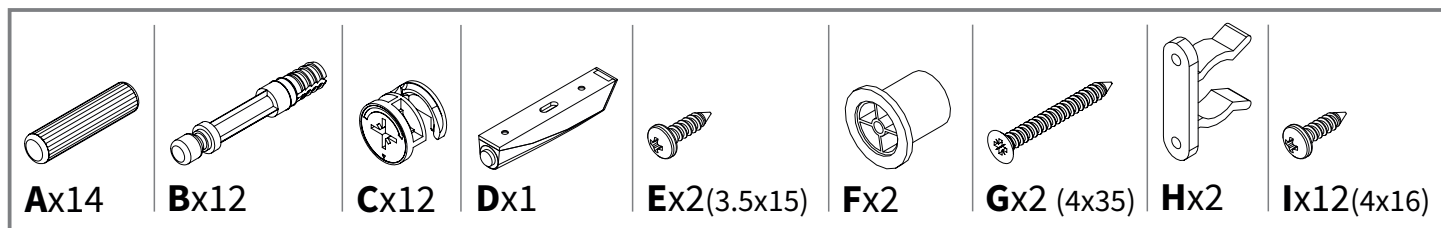

1

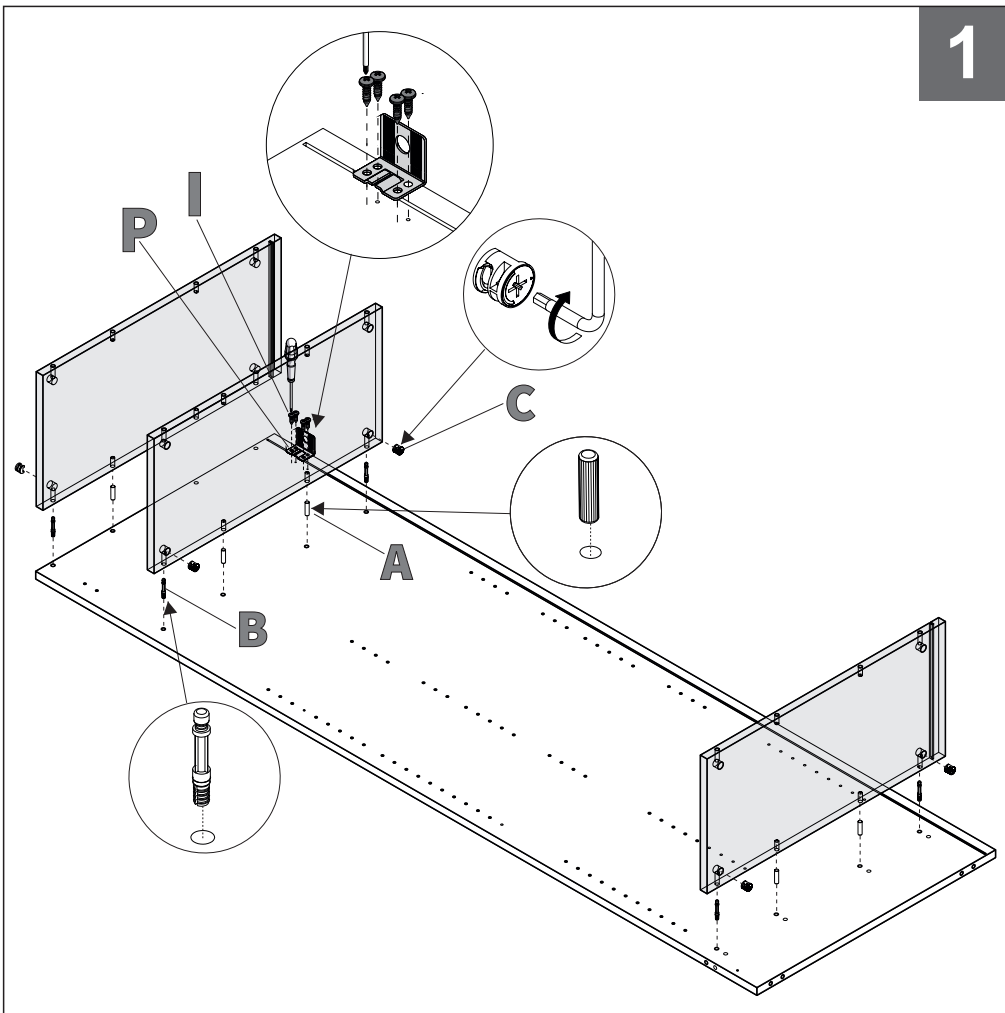

IT-Assemblaggio elementi base
 EN-Assembly base units elements
 FR-Assemblage des éléments de bases

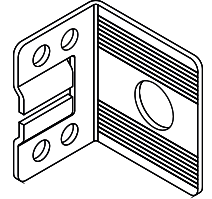

Px1



Ix4

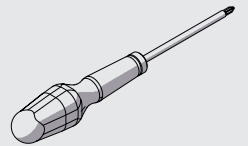

2

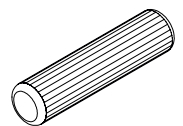
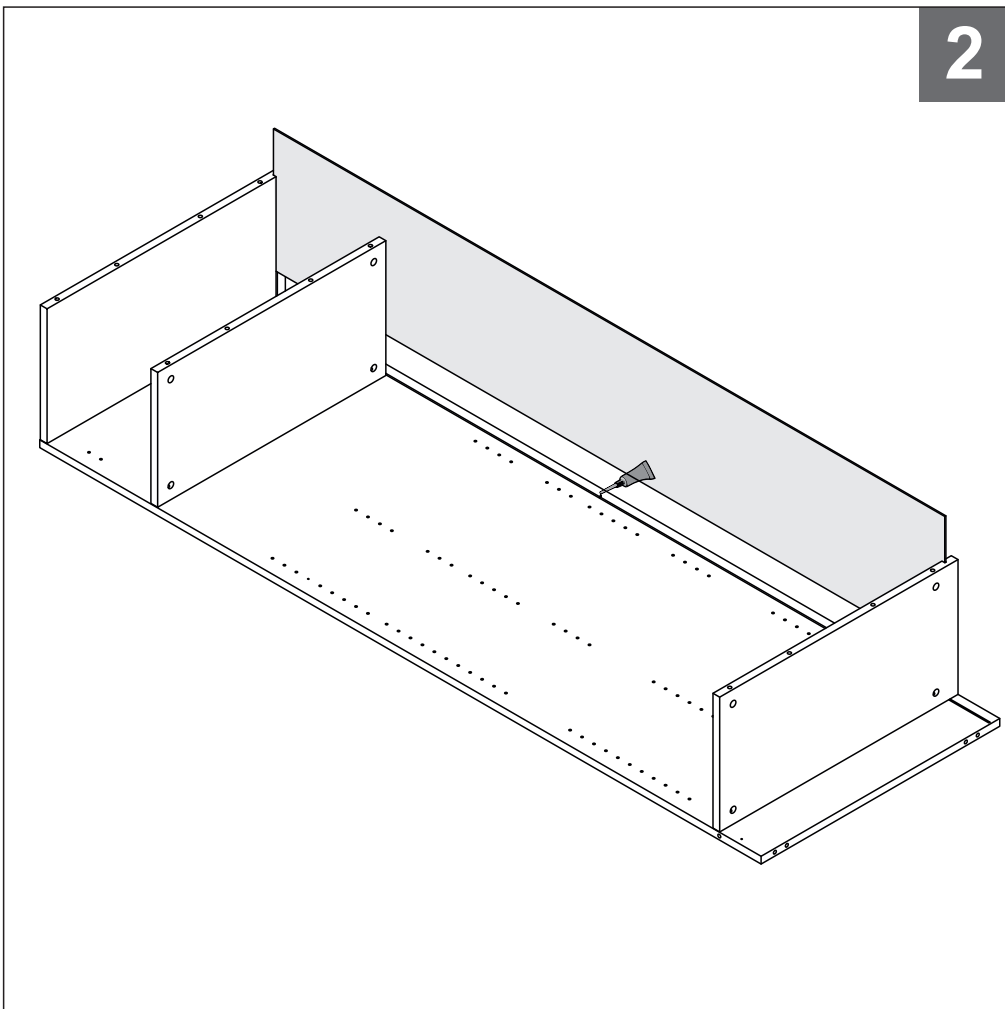

Ax6

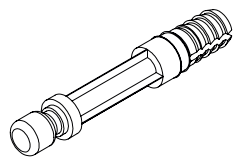

Bx6

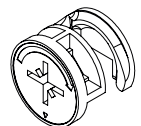

Cx6

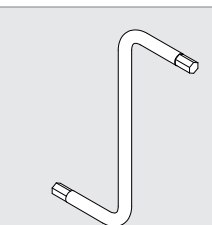

3

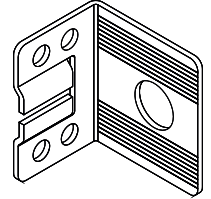
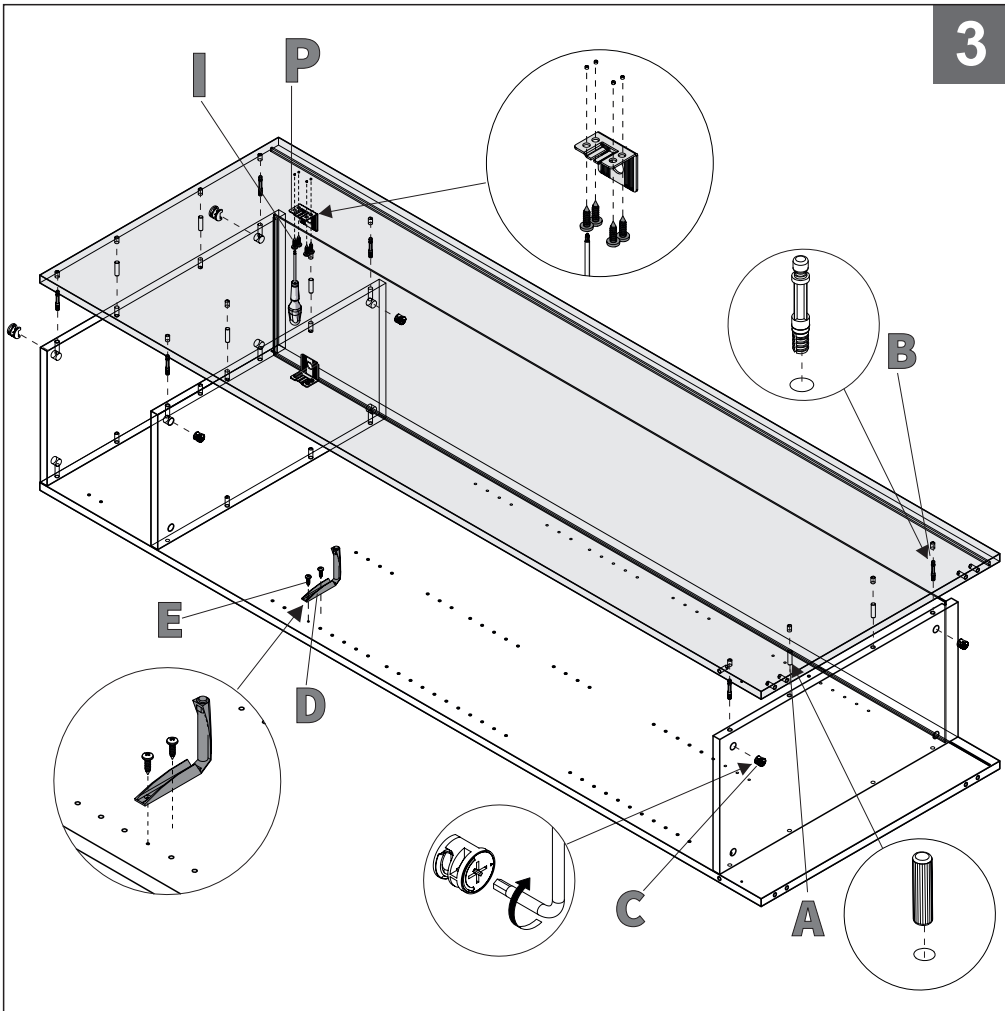

Px1



lx4

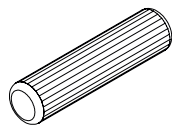
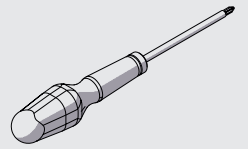

Ax6

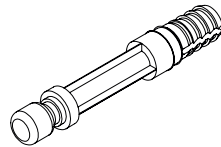

Bx6

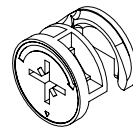

Cx6

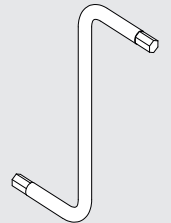

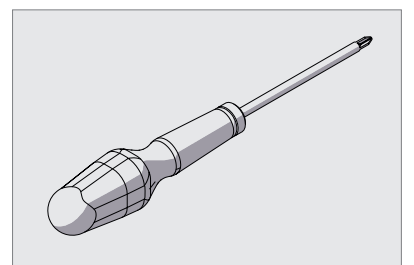
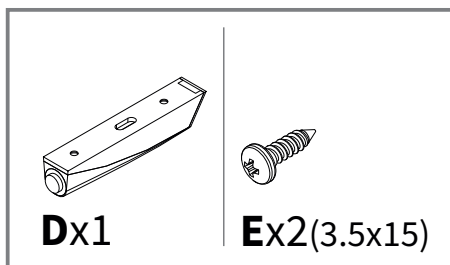
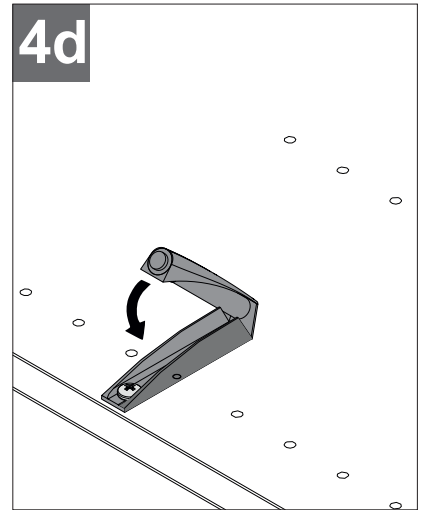
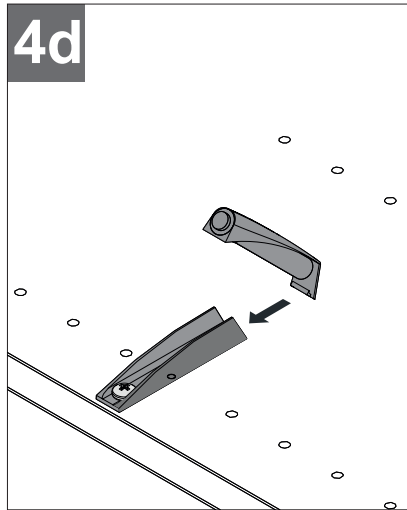
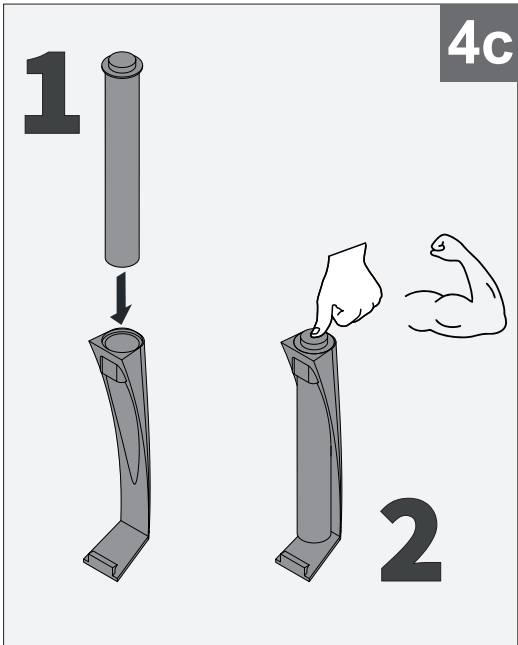
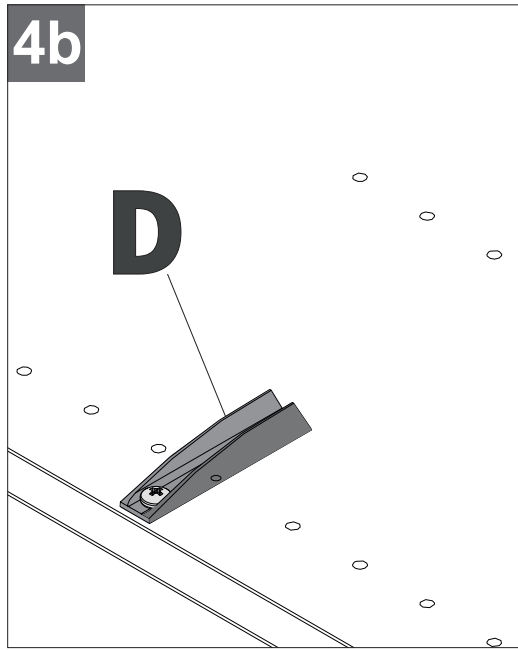
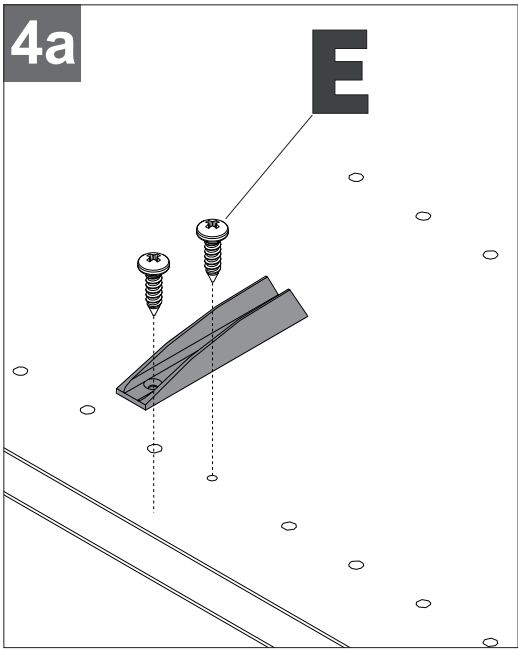

5

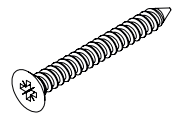
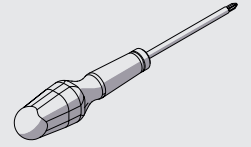
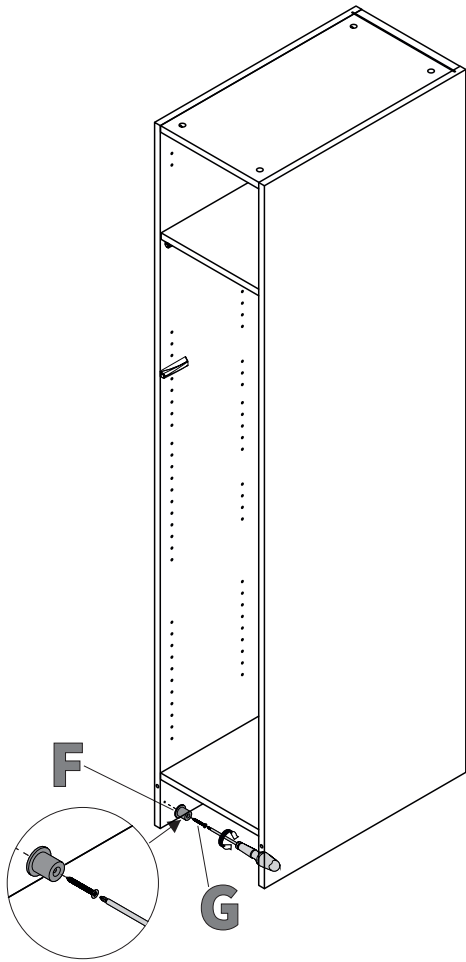

Gx2

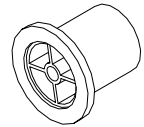

Fx2

6

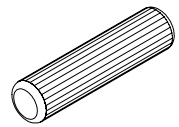
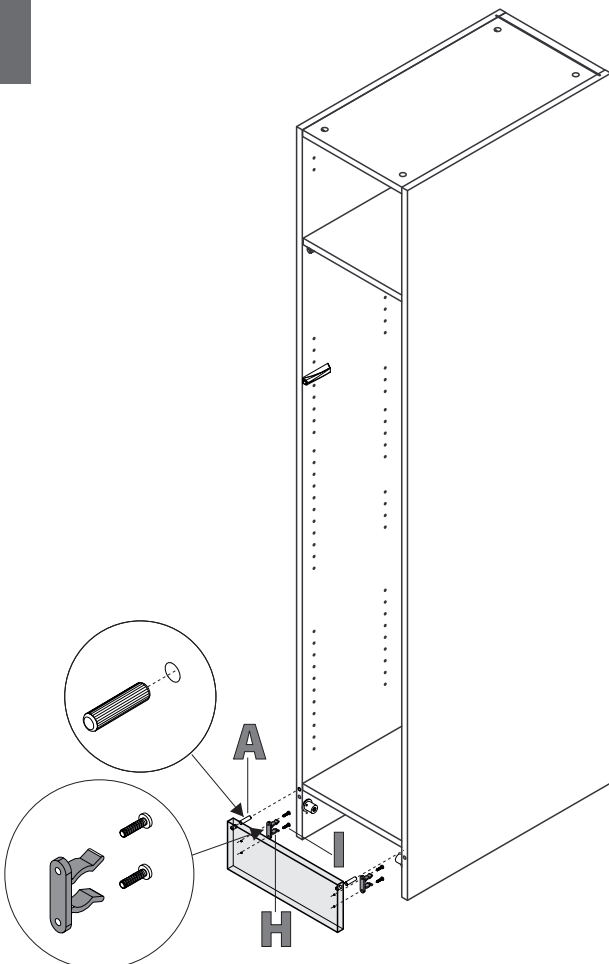

Ax2

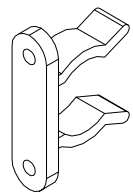

Hx2



Ix4

7

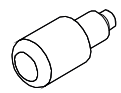
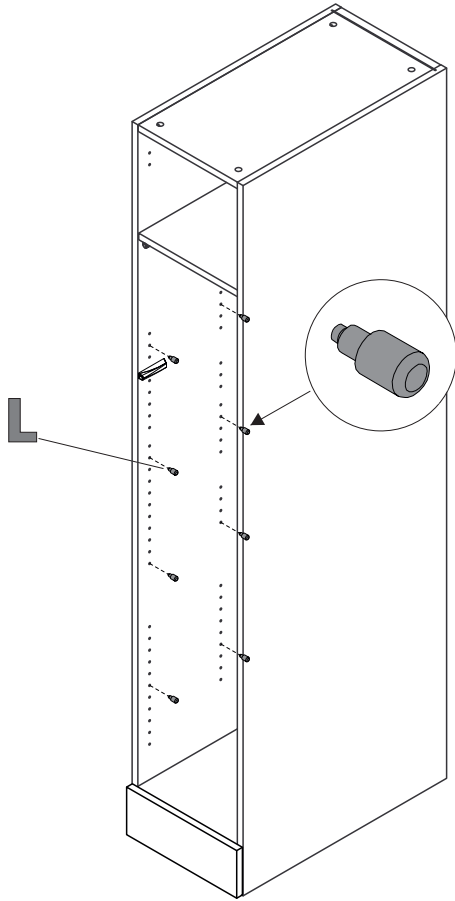

Lx16

8

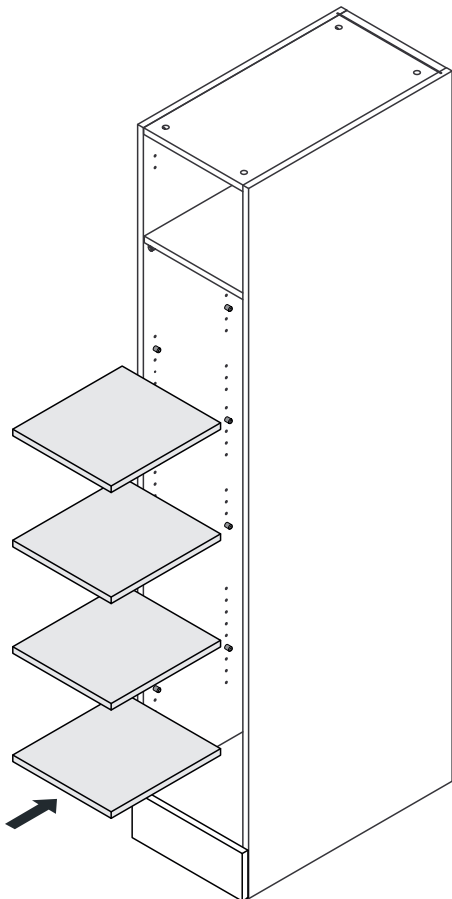

9

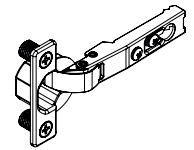
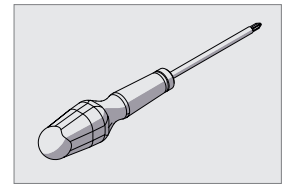
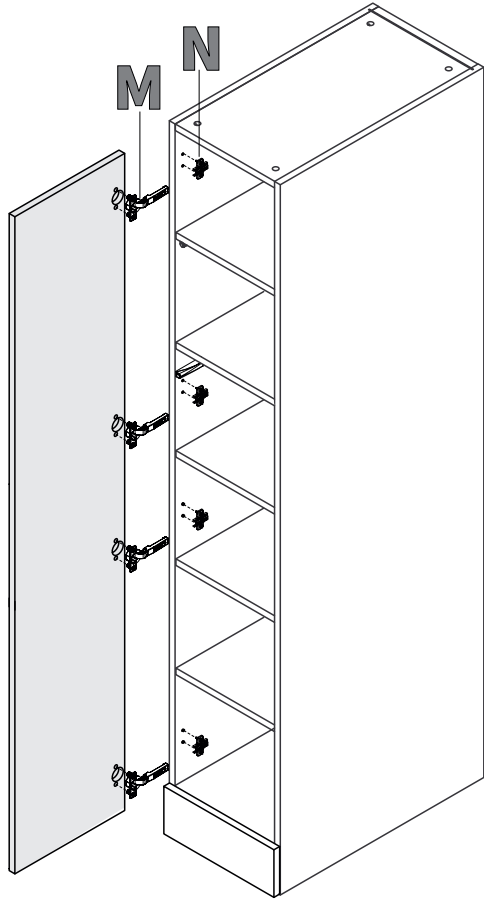

Mx4

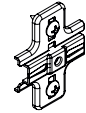

Nx4

10

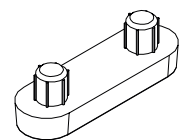
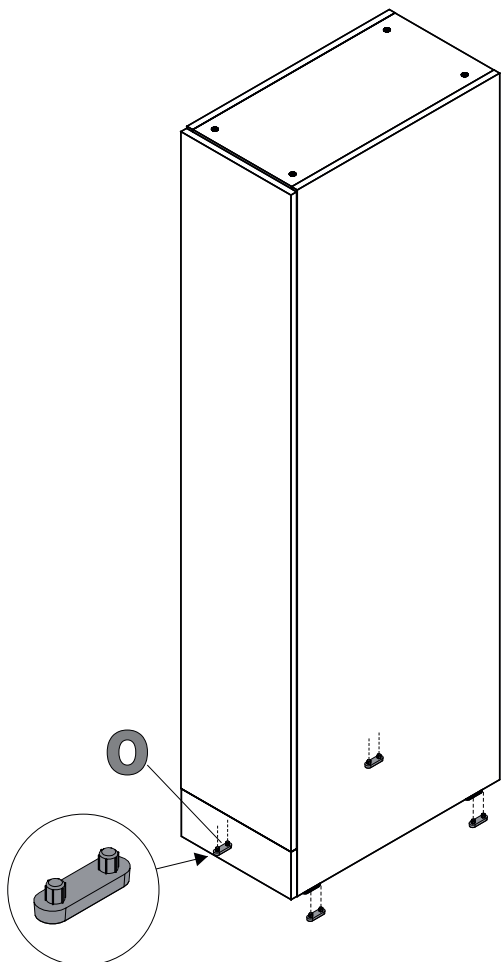

Ox4

11

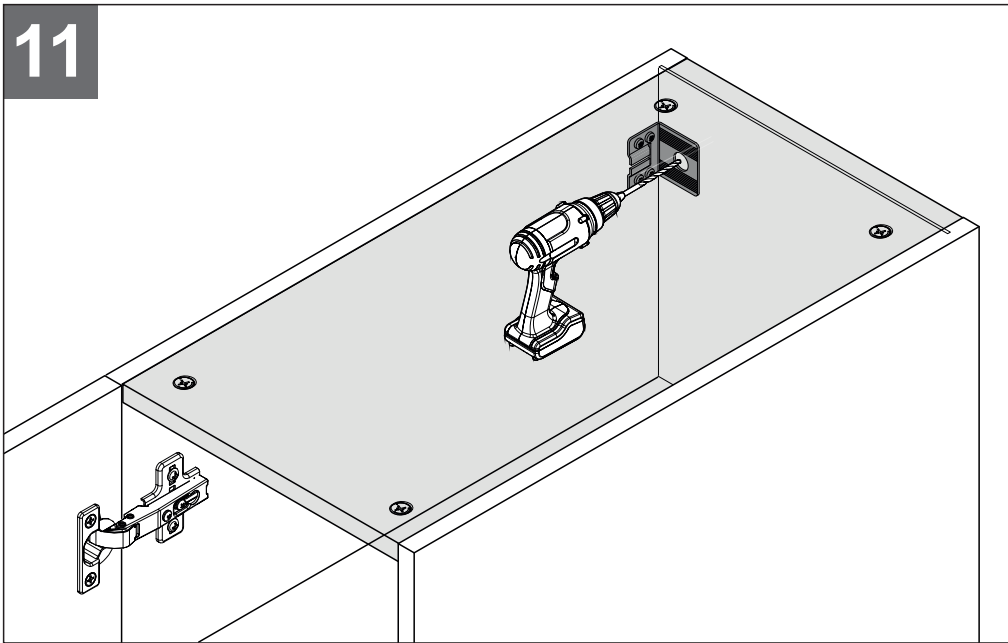

IT-Fissaggio base a parete
 EN-Fixing base unit to wall
 FR-Fixation de base au mur



Qx2

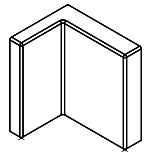

Rx2

12

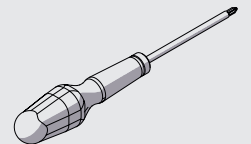
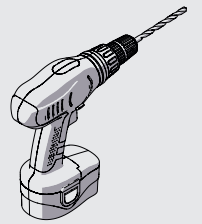
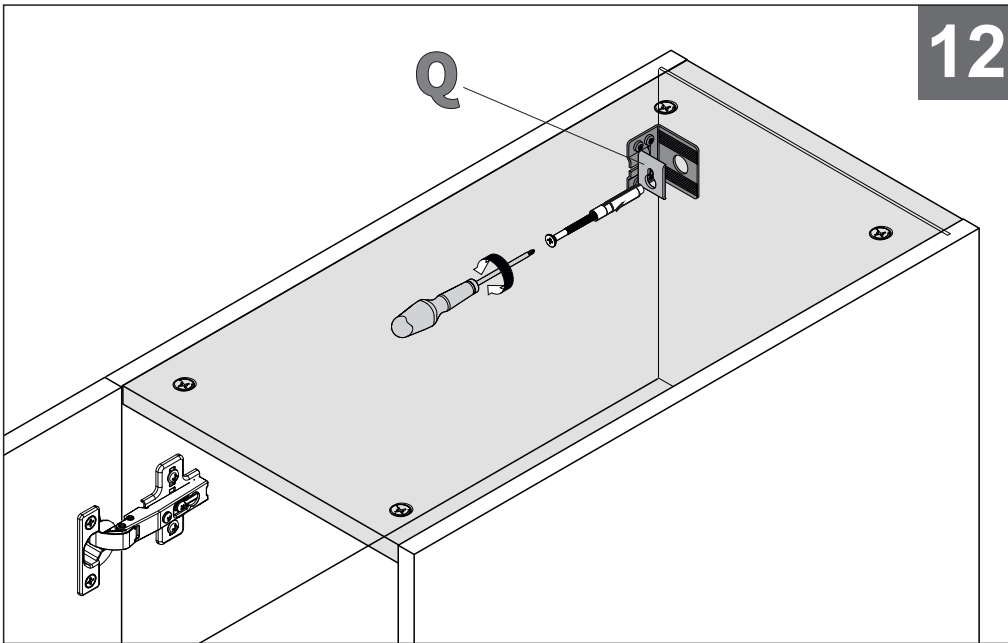

13

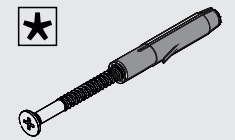
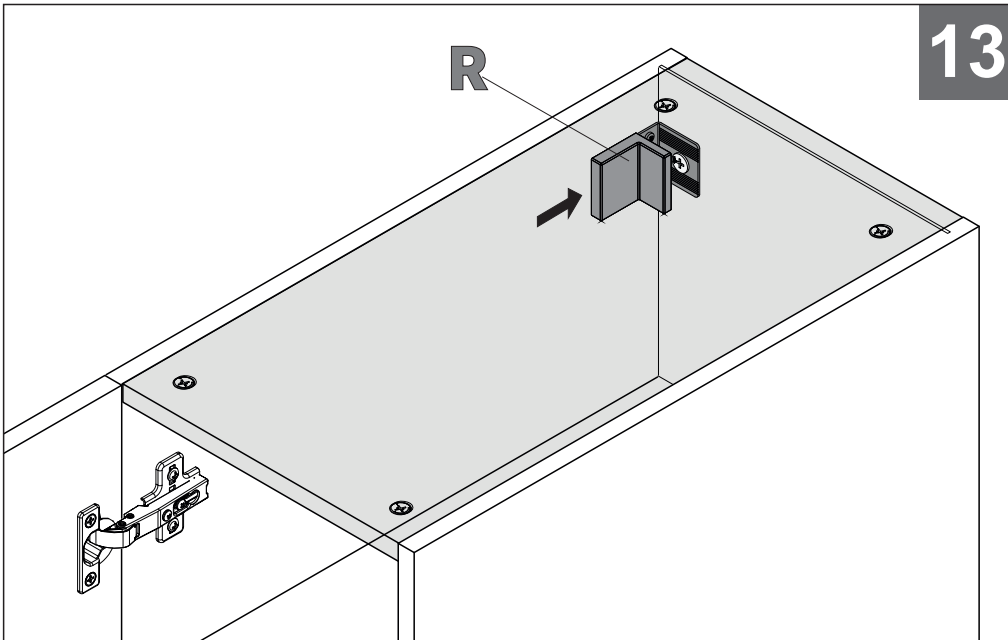

14

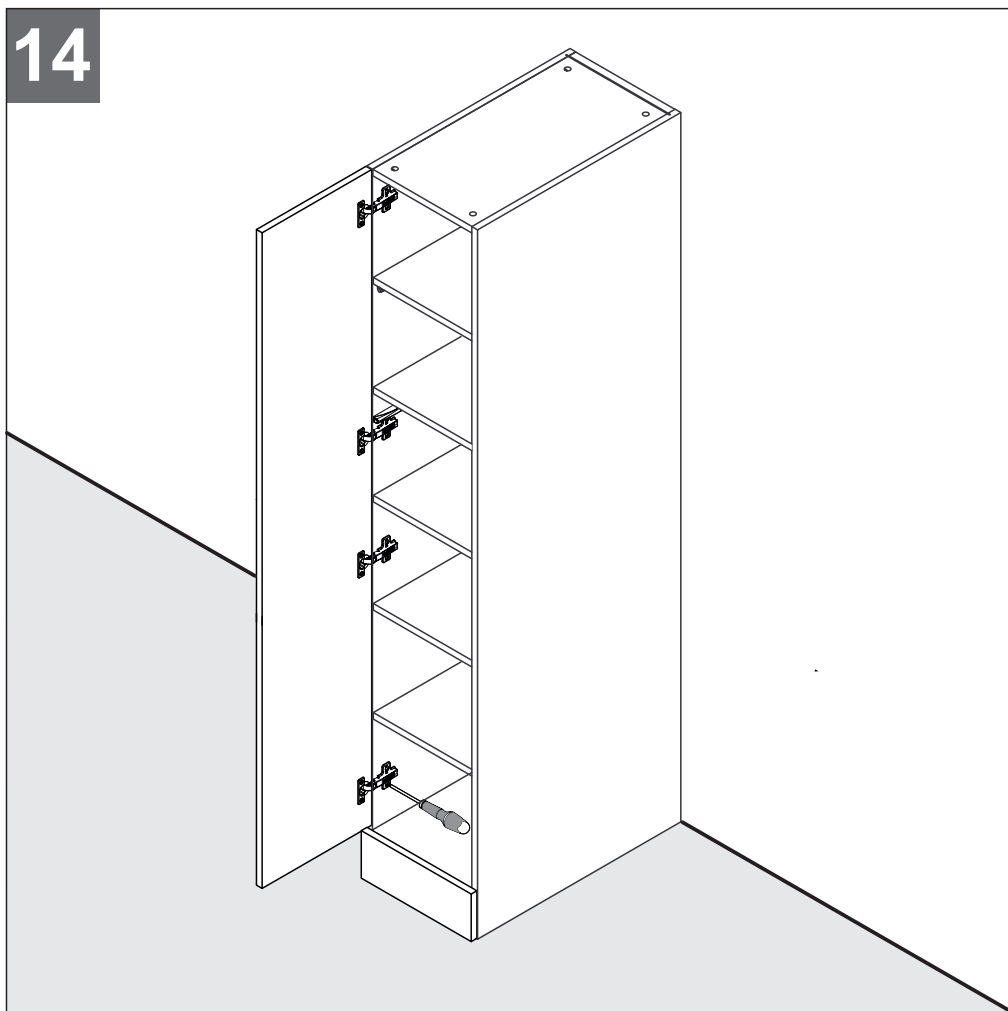

IT-Regolazione cerniere
EN-Hinges regulation
FR-Réglage des charnières

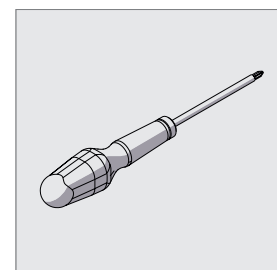

IT-Regolazione laterale
EN-Lateral adjustment
FR-Réglage latéral

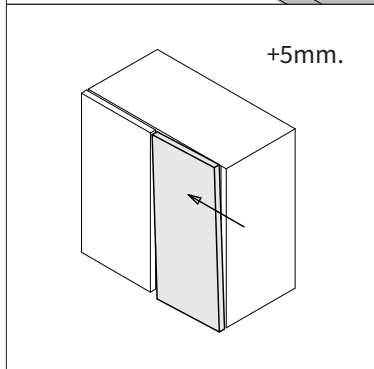
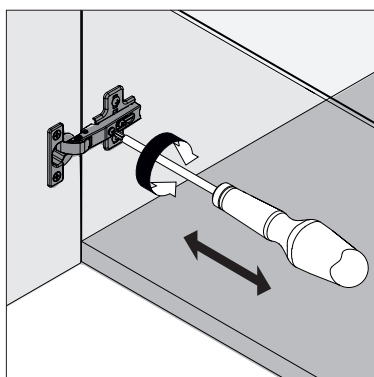

IT-Regolazione altezza
EN-Vertical adjustment
FR-Réglage en hauteur

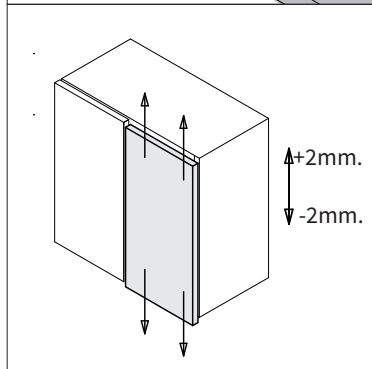
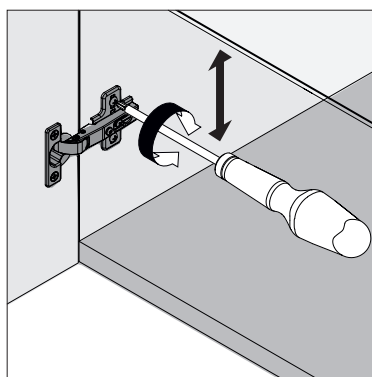

IT-Regolazione dell'inclinazione
EN-Inclination adjustment
FR-Réglage de l'inclinaison

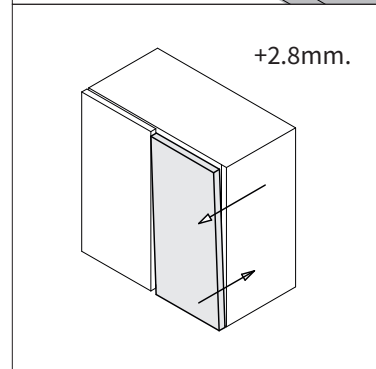
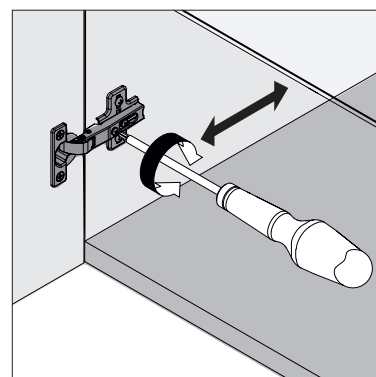

15

IT-Reversibilità colonna
EN-Column reversibility
FR-Réversibilité de la colonne

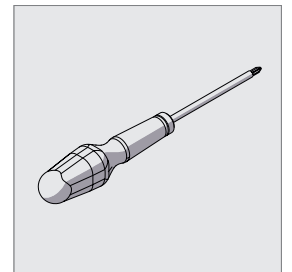
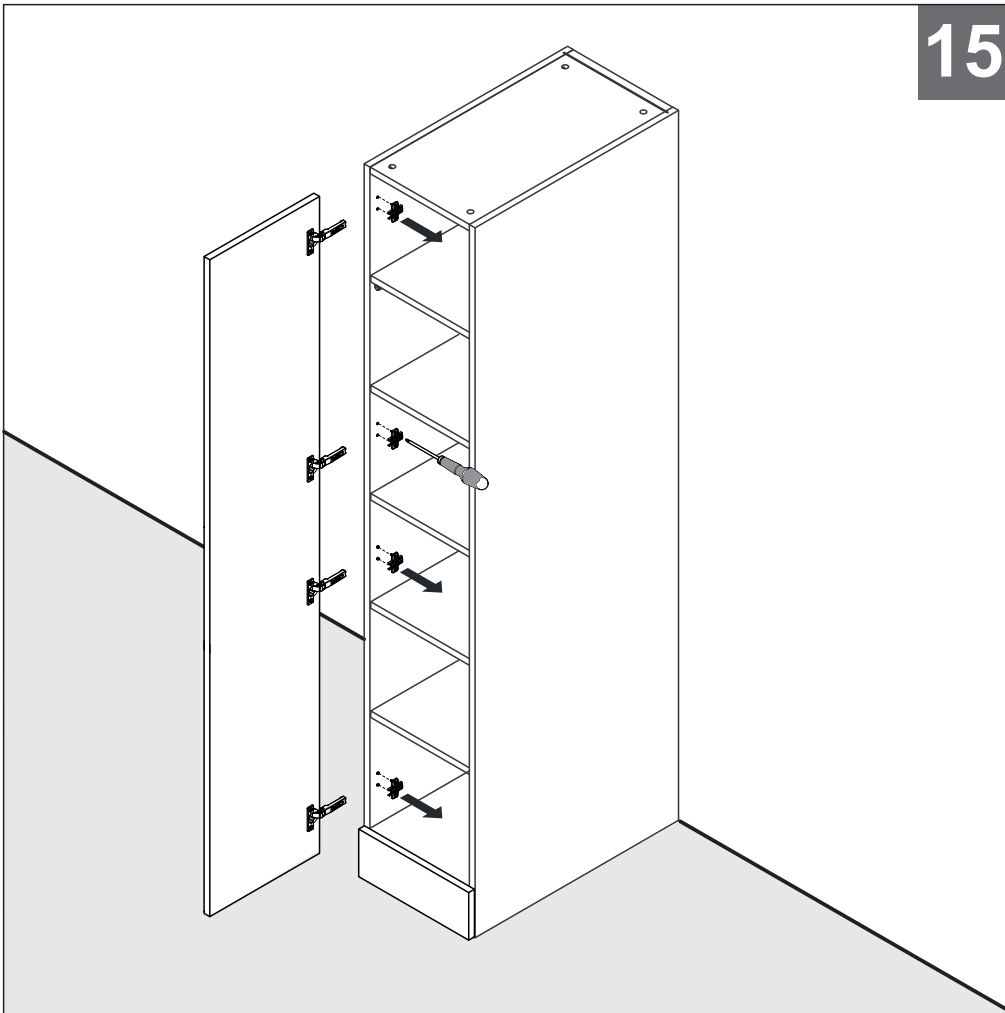

16

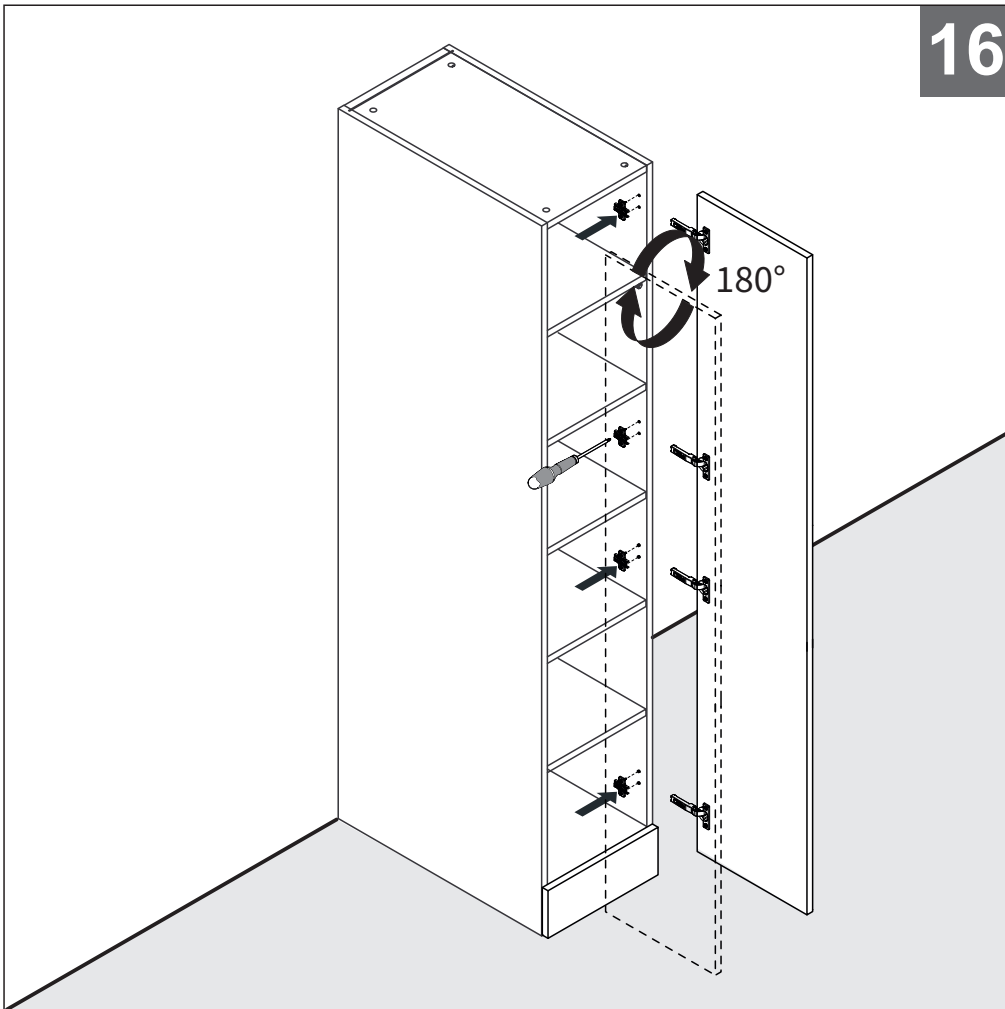

IT-Pulizia e manutenzione

EN-Cleaning and maintenance

FR-Nettoyage et entretien

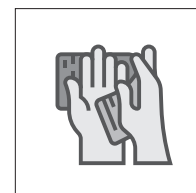
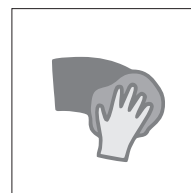

IT-Per la pulizia utilizzare esclusivamente detergenti al sapone e asciugare con un panno morbido. Non utilizzare detergenti abrasivi, corrosivi o contenenti agenti chimici, alcool, acidi o solventi. Evitare anche l'impiego di spugne abrasive, pagliette metalliche etc. che danneggerebbero irrimediabilmente le superfici del prodotto, compromettendone la lucentezza o la satinatura. In presenza di acque calcaree o aggressive asciugare dopo l'uso poiché i depositi potrebbero intaccare la superficie del prodotto.

EVITARE CHE L'ACQUA SCENDA E RISTAGNI SUL MOBILE; NEL CASO QUESTO ACCADA, ASCIUGARLO TEMPESTIVAMENTE.

EN-For cleaning use only soap detergents and dry with a soft cloth.

Do not use abrasive, corrosive or chemical agents, alcohol, acids or solvents.

Also avoid the use of abrasive sponges, metal scourers etc. that would irreparably damage the surfaces of the product, compromising the gloss or the satin finish.

In the presence of calcareous or aggressive waters, dry after use as deposits may affect the surface of the product.

DO NOT LET THE WATER COME DOWN AND STAND ON THE CABINET; IF THIS HAPPENS, DRY IT PROMPTLY.

FR-Pour le nettoyage utiliser seulement des détergents à base de savon et secher avec un chiffon doux. Ne pas utiliser de détergents abrasifs, corrosifs ou à base de produits chimiques, alcool, acides ou solvants.

Eviter aussi l'utilisation d'éponges abrasives, de produits à récurer etc.

qui endommageraient de façon permanente les surfaces du produit, en compromettant la finition brillante ou satinée.

En présence d'eaux calcaires ou agressives, secher après l'utilisation car les dépôts pourraient affecter la surface du produit.

EMPÊCHER L'EAU DE DESCENDRE ET DE STAGNER SUR LE MEUBLE ; SI CELA SE PRODUIT, SÉCHEZ-LE RAPIDEMENT.

PRODOTTO IN ITALIA

MADE IN ITALY

FABRIQUÉ EN ITALIE