

HERA

STORAGE CABINET
COLONNE DE BAIN
COLUMNA DE BAÑO
COLONNA DA BAGNO

●●randal

↔
■ 30 cm | 12 in

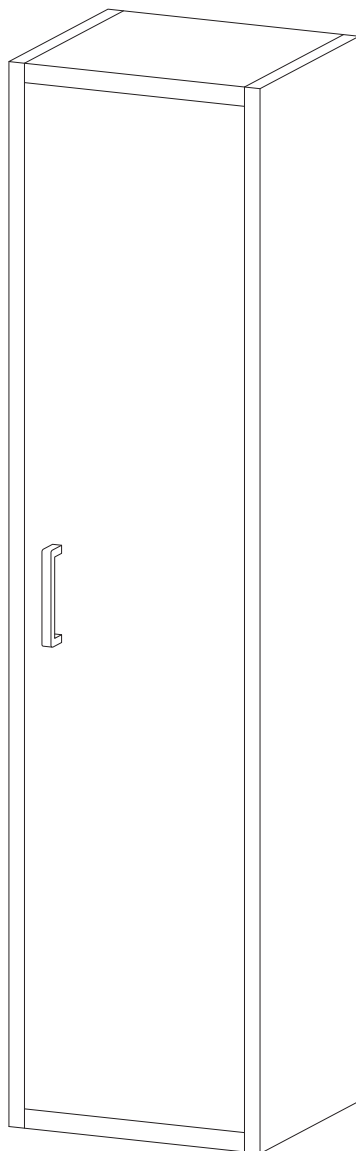

HERA

STORAGE CABINET
COLONNE DE BAIN
COLUMNA DE BAÑO
COLONNA DA BAGNO

●●randal

↔
■ 30 cm | 12 in

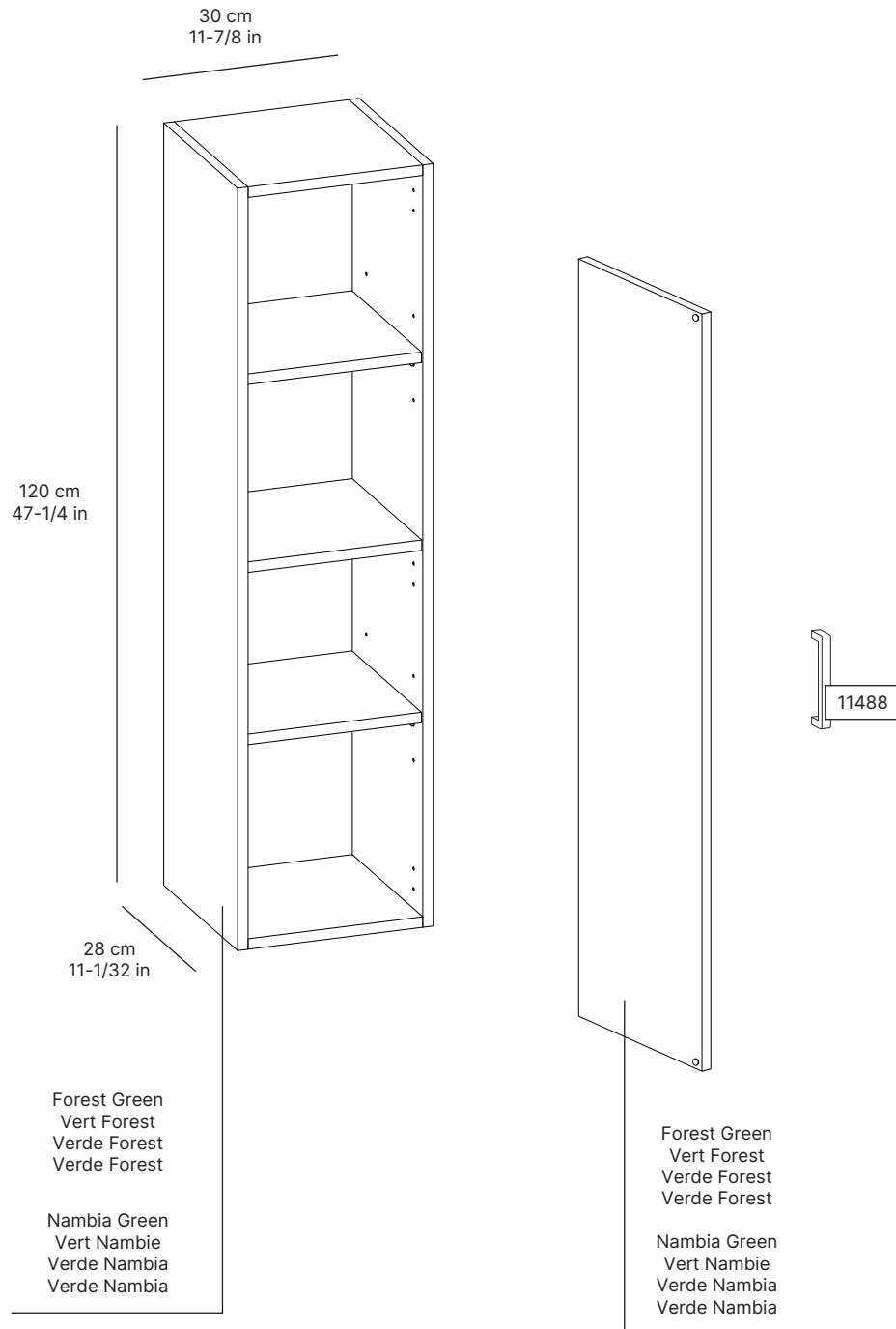

HERA

STORAGE CABINET
COLONNE DE BAIN
COLUMNA DE BAÑO
COLONNA DA BAGNO

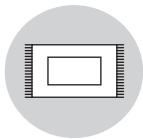

ENGLISH - Attention! Please make sure you assemble the product over a non-damaging surface. In case any piece has protective plastic film, please remove it carefully. Please, check the product finishes before installing. We will not assume extra costs for installation when the product has any imperfection. Use screws and dowels suited to your backing. Not included*.

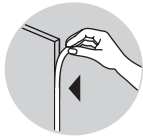

FRANÇAIS - Attention ! Réalisez le montage sur une surface douce pour éviter d'endommager les pièces. Si les pièces montrent un film protecteur sur les chants merci de le retirer soigneusement. Veuillez contrôler les finitions du produit avant son installation. Nous n'assumerons pas les surcoûts générés par l'installation d'un produit non conforme. Utilisez les vis et chevilles adaptées à votre support. Non inclus*.



ESPAÑOL - ¡Atención! Realice el montaje sobre una superficie que no dañe el acabado de las piezas. En caso de que alguna pieza lleve protectores en los cantos retírelos con cuidado. Por favor, revise los acabados del producto antes de realizar la instalación. No asumiremos sobrecostos generados por la instalación de un producto no conforme. Utilice tornillos y tacos adecuados para el soporte. No incluidos*.

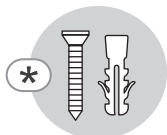

ITALIANO - ¡Attenzione! Realizzare il montaggio su una superficie che non danneggi il prodotto. Ritirare con cura eventuali protettori presenti sul bordo. Vi preghiamo di controllare le finiture del prodotto prima di realizzare l'installazione. Non ci riterremo responsabili di sovraccosti derivati da un'installazione non conforme. Utilizzare viti, rondelle e pernotti adeguati al tipo di materiale della vostra parete. Non inclusi*.



ENGLISH - Warranty does not cover:

1. Damages caused by unusual worsening or decline of the product.
2. Damages resulting from improper installation or modification of the original product.
3. Damage caused by lack of maintenance in accordance with Randal product maintenance guidelines.
4. Damages caused by accidents or overuse.

FRANÇAIS - La garantie ne couvre pas:

1. Les défauts causés par un usage inusuel et d'endommagement du produit.
2. Les défauts dérivés d'une installation incorrecte ou d'une modification du produit original.
3. Les défauts causés par un manque d'entretien non conforme aux directrices d'entretien des produits marque Randal.
4. Les défauts occasionnés par accidents ou usage excessif en dehors du milieu domestique.

ESPAÑOL - La garantía no cubre:

1. Daños causados por desgaste inusual y deterioro en el producto.
2. Los daños resultantes de una incorrecta instalación o de la modificación del producto original.
3. Daños causados por falta de mantenimiento de acuerdo con las directrices de mantenimiento de productos de Randal.
4. Los daños ocasionados por accidentes o abuso.

ITALIANO - La garanzia non copre:

1. Danni causati per un uso incorretto o usura del prodotto.
2. I danni risultanti da un'incorretta installazione o da una modificazione del prodotto originale.
3. Danni derivati da una manutenzione inadeguata o che non ha rispettato le direttrici di manutenzione del prodotto di Randal.
4. I danni ocasionati per rotture o abusi.

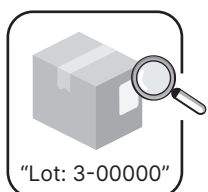

"Lot: 3-00000"

ENGLISH - Please enter the batch number of your furniture in this box and keep this form. You must include it with the purchase ticket for after-sales service management. You will find it on the label of the outer box and on one side of the furniture.

FRANÇAIS - Veuillez noter dans l'encadré le numéro de lot de votre meuble et conserver cette feuille. Vous devrez l'apporter avec le ticket de caisse pour toute gestion au service après-vente. Vous le trouverez sur la boîte extérieure et sur un latéral du meuble.

ESPAÑOL - Por favor, anote en este recuadro el número de lote de su mueble y conserve esta hoja. Deberá aportarlo junto al ticket de compra para cualquier gestión del servicio postventa. Lo encontrará en la caja exterior y en un lateral del mueble.

ITALIANO - Vi preghiamo di scrivere in questo spazio il numero di lotto del prodotto e conservare questo foglio. Dovrà essere presentato assieme al ticket di acquisto per qualsiasi gestione del servizio post-vendita. Il suddetto è situato sul cartone esteriore e anche in un fianco del prodotto.

Lot: _____

HERA

STORAGE CABINET
COLONNE DE BAIN
COLUMNNA DE BAÑO
COLONNA DA BAGNO



30 cm | 12 in

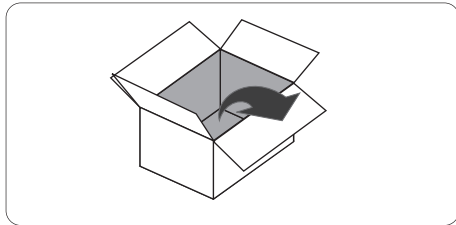

$\frac{3498}{x2}$



$\frac{11488}{x1}$

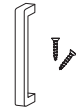

$\frac{3686}{x2}$



$\frac{7464}{x2}$

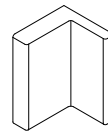

$\frac{1248}{x8}$

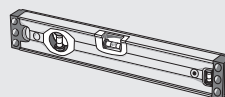
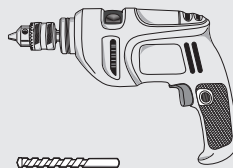
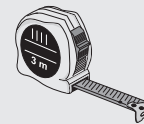
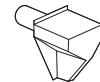

1

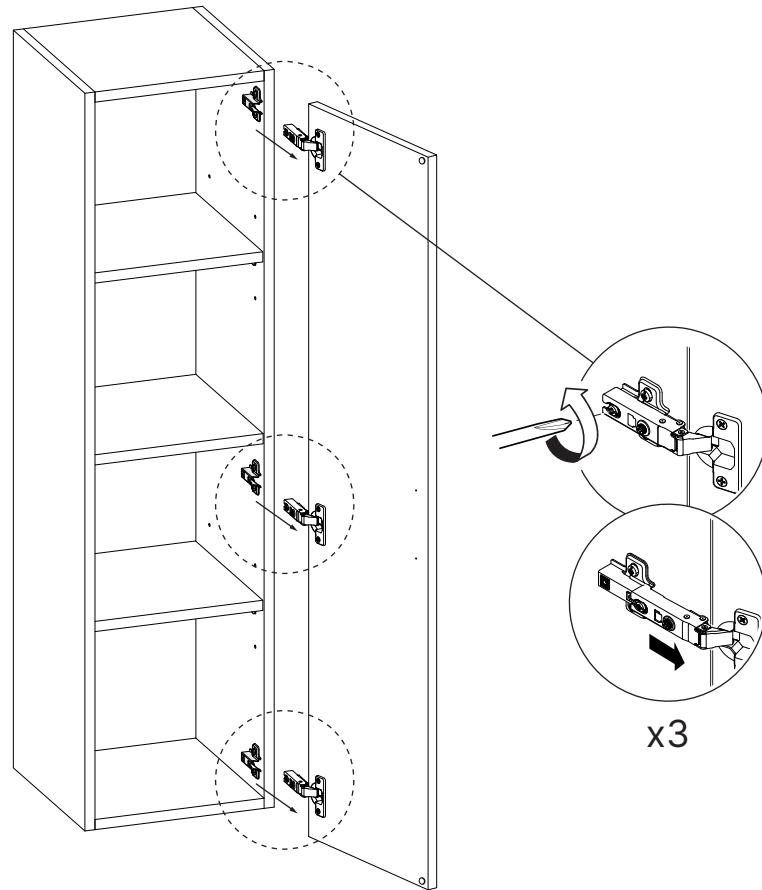

2

 30 cm | 12 in

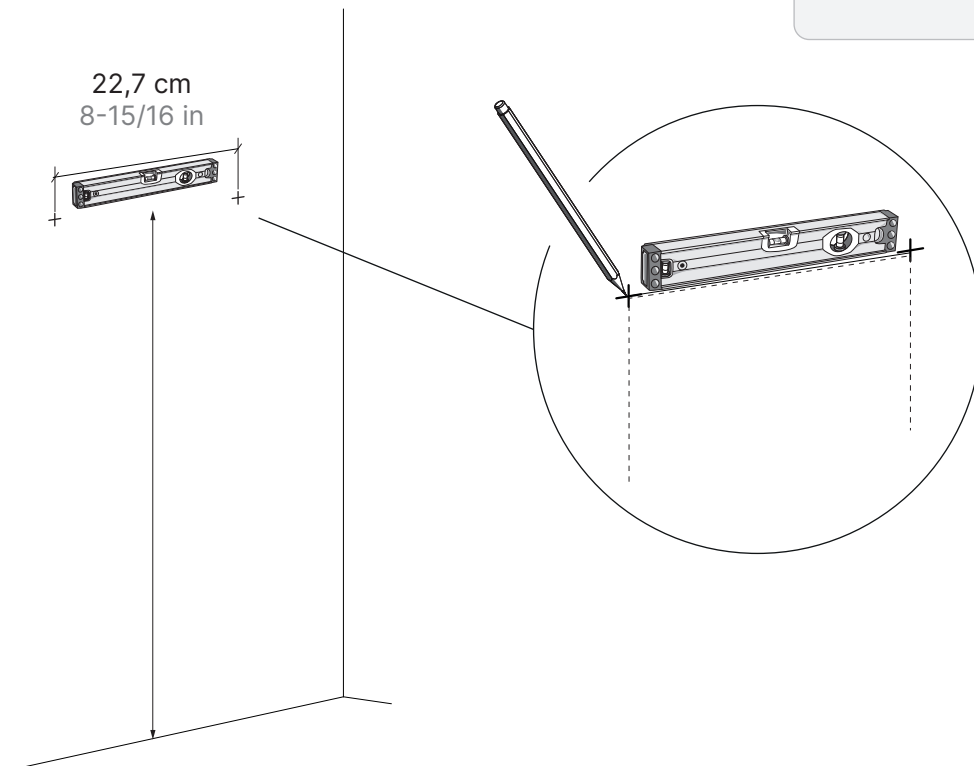
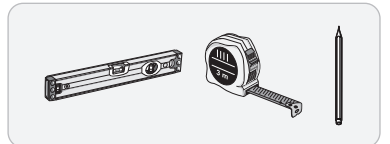

3

↔ 30 cm | 12 in

3686
x2

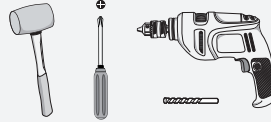

* Not included.
Non inclus.
No incluido.
+
Non inclus.

1

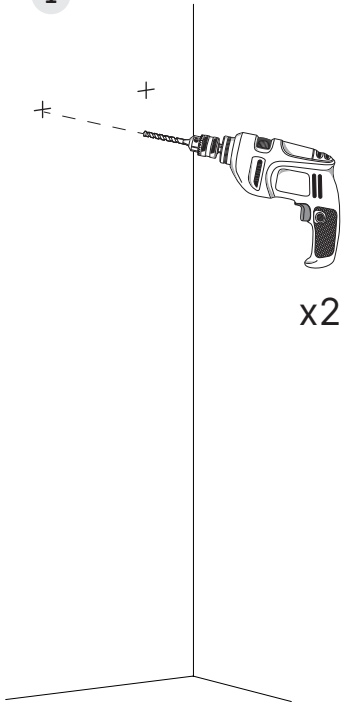

2

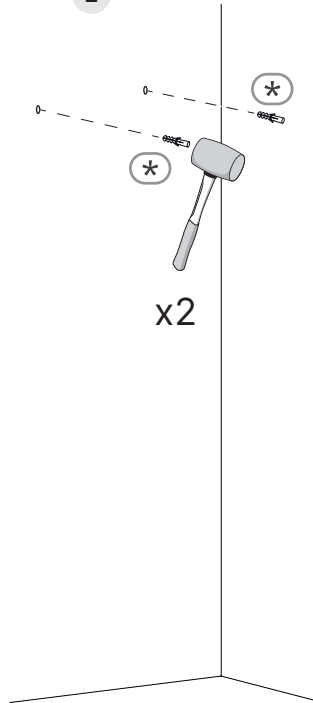

3

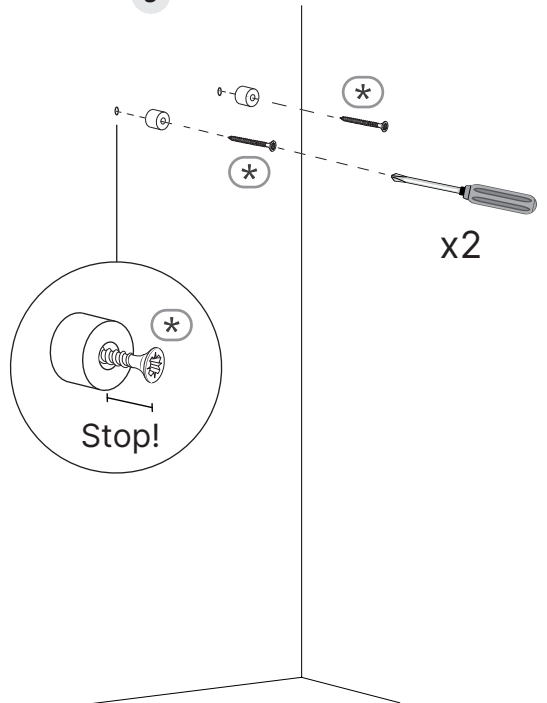

4

7464
x2



3498
x2

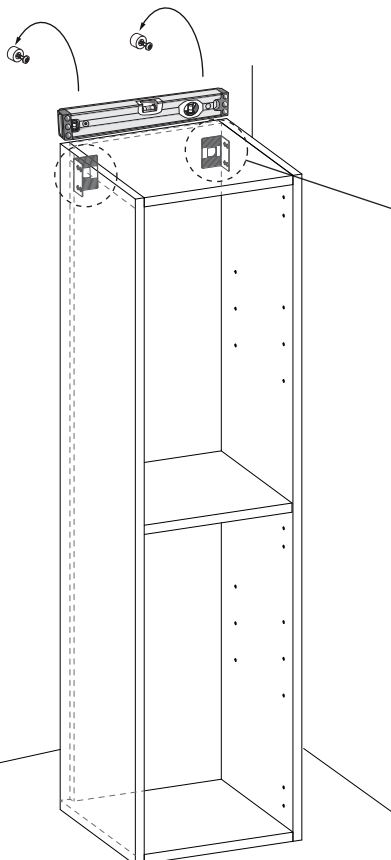
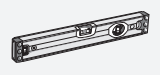

1

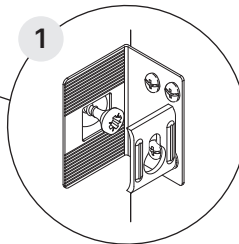

2

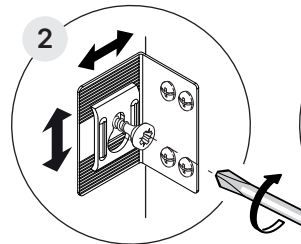

3

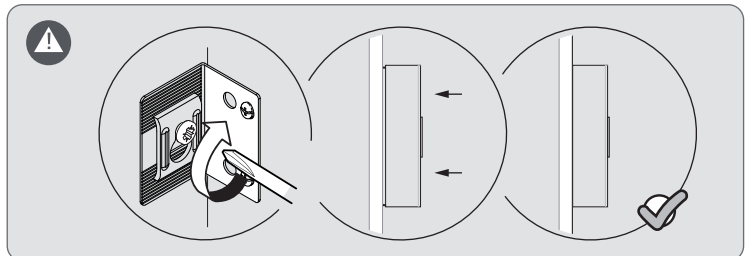
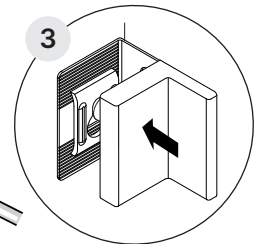

5

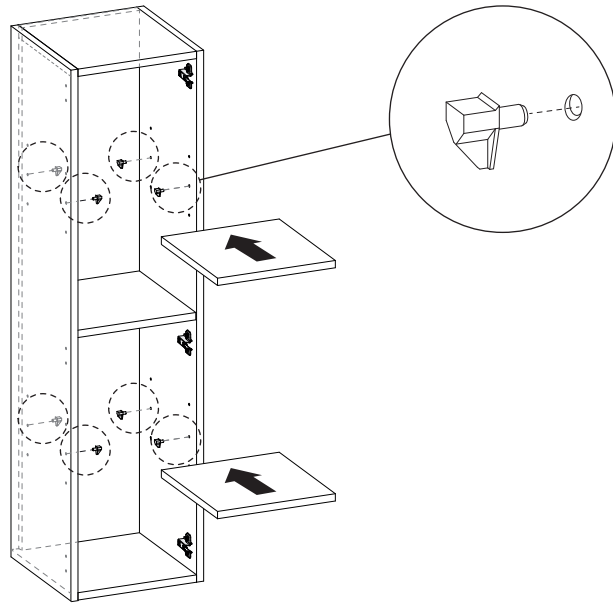

1248
x8



6

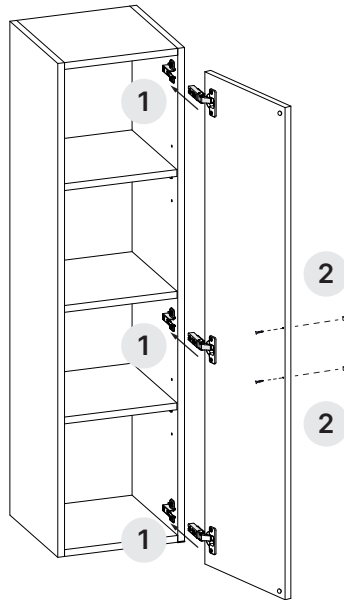
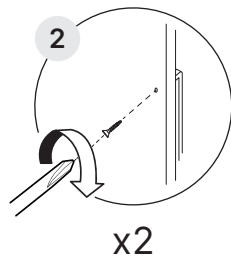
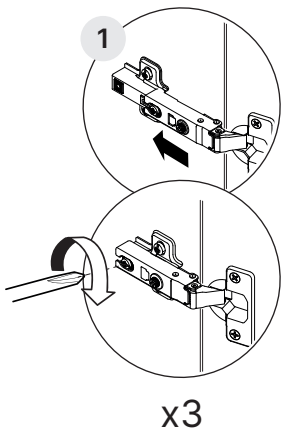

11488
x1

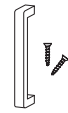

7

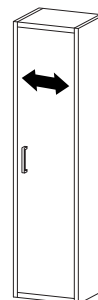
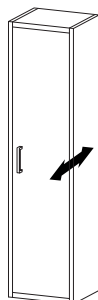
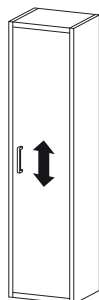
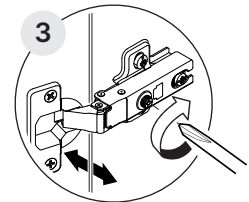
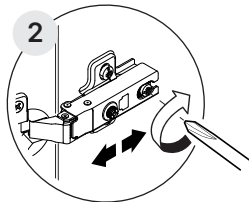
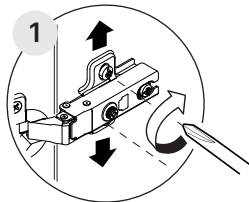



ENGLISH - For day-to-day cleaning, simply wipe the vanities with a soft, damp cloth and a little mild detergent if necessary. Avoid cleaning agents that include ammonia, alcohol, bleach or abrasives. Rinse afterwards with clean water and then dry with a clean, dry cloth. Do blot up spills immediately. Please avoid exposing the furniture to high concentrations of steam or other forms of moisture. Keeping your bathroom ventilated is highly recommended.



FRANÇAIS - Pour l'entretien habituel du meuble, veuillez nettoyer la surface avec un chiffon légèrement humidifié à l'eau et la sécher rapidement. Ne pas utiliser de lessives composées d'ammoniaque, d'alcool, d'eau de javel ou d'autres produits abrasifs. Il est recommandé de sécher toute eau stagnante. Evitez que le meuble soit exposé à des concentrations excessives de vapeur ou autres formes d'humidité. Nous vous recommandons une bonne ventilation dans votre salle de bain.



ESPAÑOL - Para el mantenimiento diario de su mueble, limpie la superficie con un paño ligeramente humedecido de agua y seque rápidamente. Evite detergentes que incluyan amoníaco, alcohol, lejía u otros abrasivos. Es conveniente secar cualquier derrame de agua que se haya producido. Evite exponer el mueble a excesivas concentraciones de vapor u otras formas de humedad. Le aconsejamos ventilar bien su cuarto de baño.

ITALIANO - Per la manutenzione giornaliera del prodotto, si consiglia di pulire la superficie con un panno leggermente inumidito in acqua ed asciugare a continuazione. Evitare detersivi che includano ammoniacca, alcool, candeggina o altri prodotti abrasivi. È conveniente asciugare qualsiasi fuoriuscita d'acqua. Evitare esporre il prodotto ad eccessive concentrazioni di vapore o altre forme d'umidità. Consigliamo inoltre di ventilare bene la stanza di bagno.

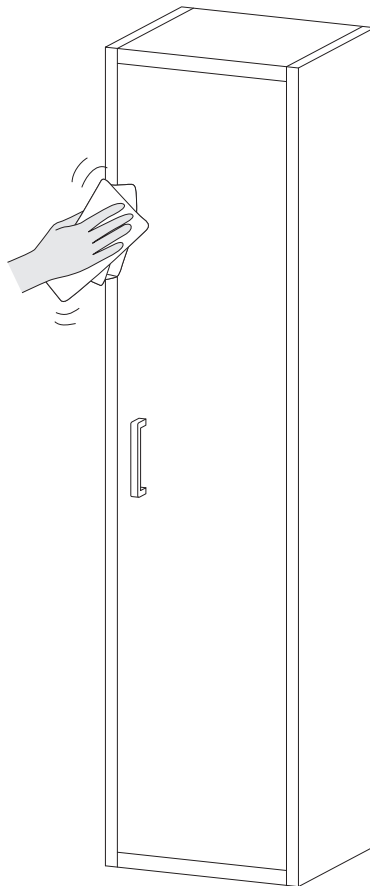

●● randal

Randal Europea, S.A.
Calle Ciudad de Liria, 120
Pol. Ind. Fuente del Jarro, 46988
Paterna, Valencia, Spain

+34 961 539 000
www.randal.group
info@randal.group

11450.V01

EMPRESA ASOCIADA
AIDIMME
INSTITUTO TECNOLÓGICO

 **ISO 9001**
LL-C (Certification)

 **ISO 14001**
LL-C (Certification)



PEFC/14-35-00240

PEFC Certified

Bathroom furniture from sustainably managed forests, recycled and controlled sources

www.pefc.co.uk

PEFC Certificado

Este mueble de baño procede de bosques gestionados de forma sostenible, reciclado y fuentes controladas

www.pefc.es

Certificato PEFC

Questo mobile da bagno da foreste gestite in maniera sostenibile, riciclata e da fonti controllate

www.pefc.it

Certifié PEFC

Ce meuble de salle de bains de forêts gérées durablement, de sources recyclées et contrôlées

www.pefc-france.org