

8 x2

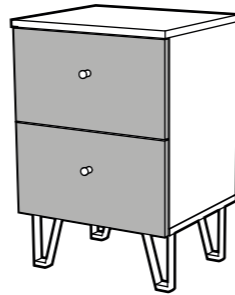
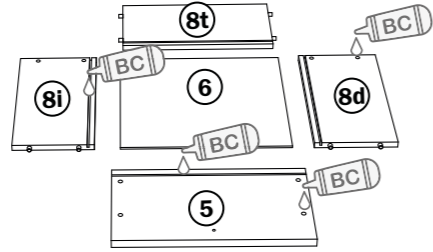
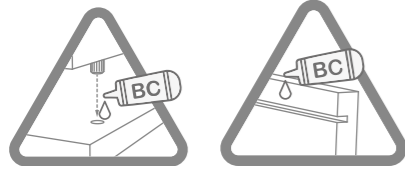
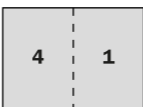
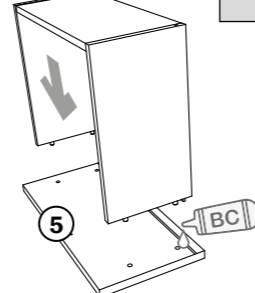
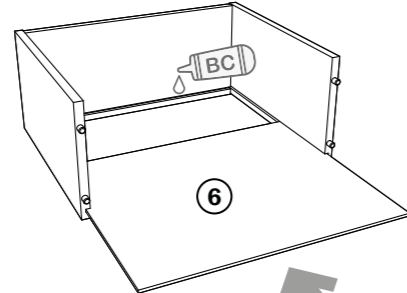
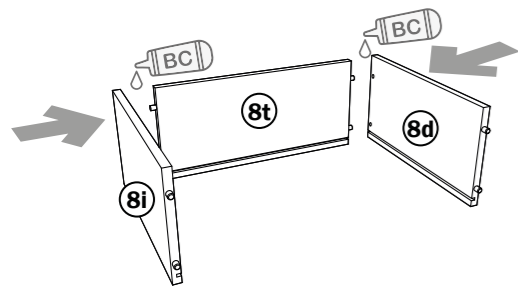

CAJONERA

Armário de Gavetas - Drawer Unit - Bloc-Tiroirs

2 Cajones
2 Gavetas
2 Drawers
2 Tiroirs

Ardila

K-631

Alto: 594 mm
Altura - Height - Hauteur
Ancho: 402 mm
Largura - Width - Largeur
Fondo: 350 mm
Profundidade - Depth - Profondeur

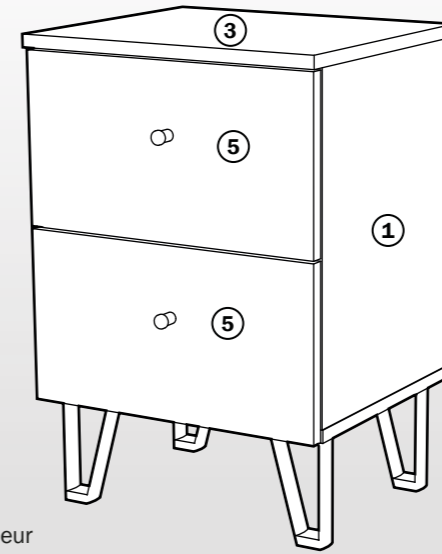

9 x2

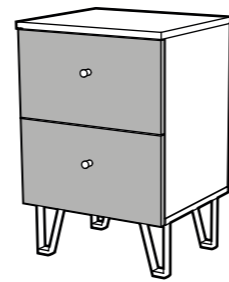
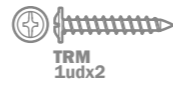
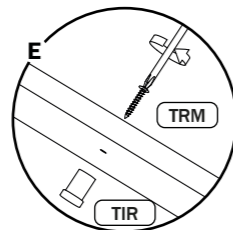
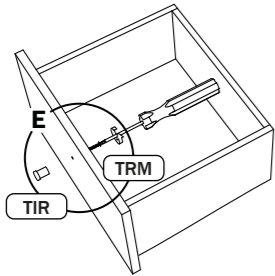

10 x2

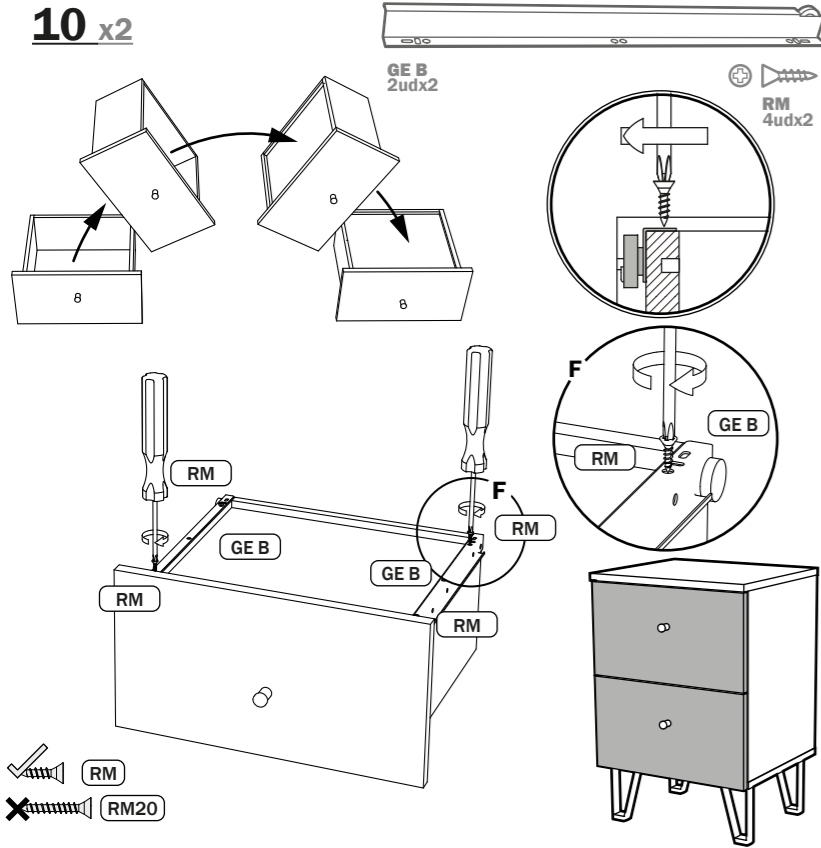

11

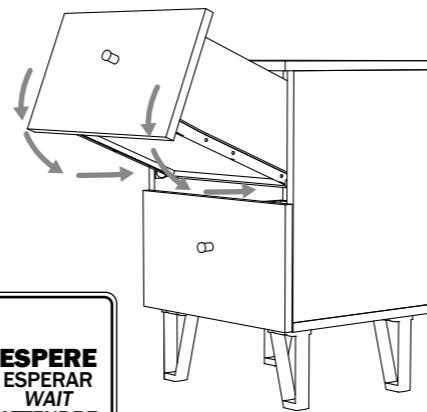

ES. Para evitar deformaciones del cajón, colóquelo durante 24h en su posición correcta dentro del mueble sin manipularlo ni añadir peso.

PT. Para evitar a deformação da gaveta, colocá-la durante 24 horas na sua posição correcta dentro do mobiliário sem a manusear ou adicionar peso.

EN. To avoid deformation of the drawer, place it for 24 hours in its correct position inside the cabinet without handling it or adding weight.

FR. Pour éviter la déformation du tiroir, placez-le pendant 24 heures dans sa position correcte à l'intérieur du meuble sans le manipuler ni lui ajouter de poids.

PARA MÁS INFORMACIÓN ESCANEAR EL CÓDIGO BIDI
PARA MAIS INFORMAÇÕES, VOCÊ PODE DIGITALIZAR O CÓDIGO BIDI
FOR MORE INFORMATION YOU CAN SCAN THE BIDI
POUR PLUS D'INFORMATION VOUS SCANNER LE CODE BIDI



ES Conserve esta etiqueta para cualquier tipo de reclamación
PT Guarde este rótulo para qualquer tipo de reclamação
EN Keep this label for any requests you may have.
FR Conservez cette étiquette pour tout type de réclamation



plegar por la línea - dobre ao longo da linha - fold along the line - plier le long de la ligne

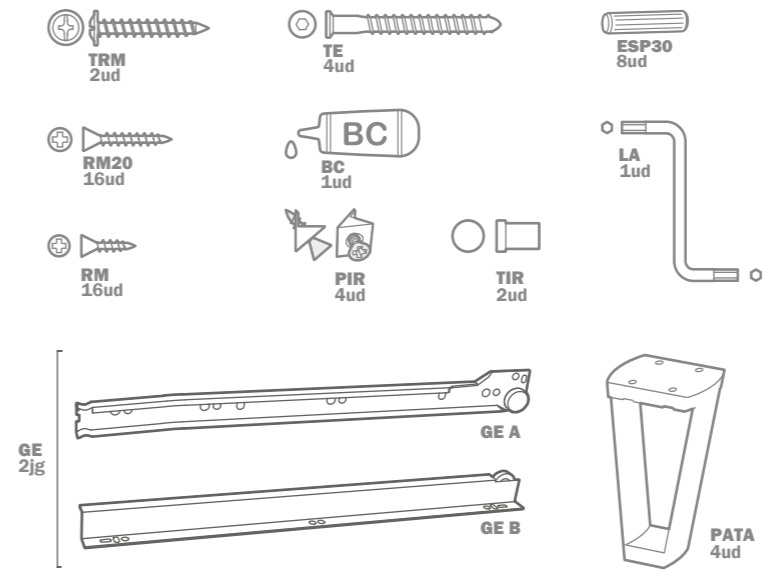

ES. No ingerir. Agitar antes de usar.
PT. Não ingerir. Agite antes de usar.
EN. Do not swallow. Shake before use.
FR. Ne pas ingérer. Agiter avant utilisation.

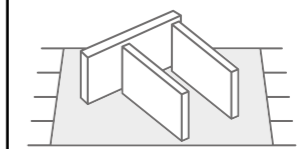

ES. Montaje del mueble sobre una superficie de protección.
PT. Monte os móveis em uma superfície protetora.
EN. Mount the furniture on a protective surface.
FR. Montez le meuble sur une surface de protection.

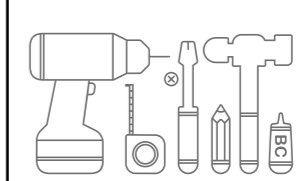

ES. Material necesario para el montaje del mueble.
PT. Material para o qual você deve usar montagem.
EN. Material that you have to use for assembly.
FR. Matériel que vous devez utiliser pour l'assemblage.



ES. El montaje del mueble deberá realizarse siguiendo las instrucciones del fabricante, en caso contrario, puede haber riesgo de seguridad por caída o vuelco. Podría provocar lesiones graves. Siga las siguientes instrucciones de seguridad:
- Evite poner objetos pesados sobre el producto.
- Evite que los niños se apoyen en los cajones o estantes.

- Coloque los objetos más pesados en la parte inferior del mueble.
PT. Os móveis devem ser montados de acordo com as instruções do fabricante, caso contrário pode haver perigo de queda ou tombamento. Isto pode resultar em ferimentos graves.

As instruções de segurança devem ser seguidas:
- Evitar colocar objectos pesados sobre o mobiliário.
- Evitar que as crianças se inclinem ou trepem em gavetas ou prateleiras.

- Colocar os objectos mais pesados sobre o fundo do mobiliário.
EN. The furniture must be assembled in accordance with the manufacturer's instructions, otherwise there may be a safety danger of falling or tipping over. This could result in serious injury.

Safety instructions must be followed:
- Avoid placing heavy objects on the furniture.
- Prevent children from leaning or climbing on drawers or shelves.
- Place the heaviest objects on the bottom of the furniture.

FR. Les meubles doivent être montés conformément aux instructions du fabricant, sinon il peut y avoir un risque de chute ou de basculement. Cela pourrait entraîner des blessures graves. Les consignes de sécurité doivent être respectées:
- Évitez de placer des objets lourds sur le meuble.
- Empêchez les enfants de s'appuyer ou de grimper sur les tiroirs ou les étagères.
- Placez les objets les plus lourds sur le bas du meuble.

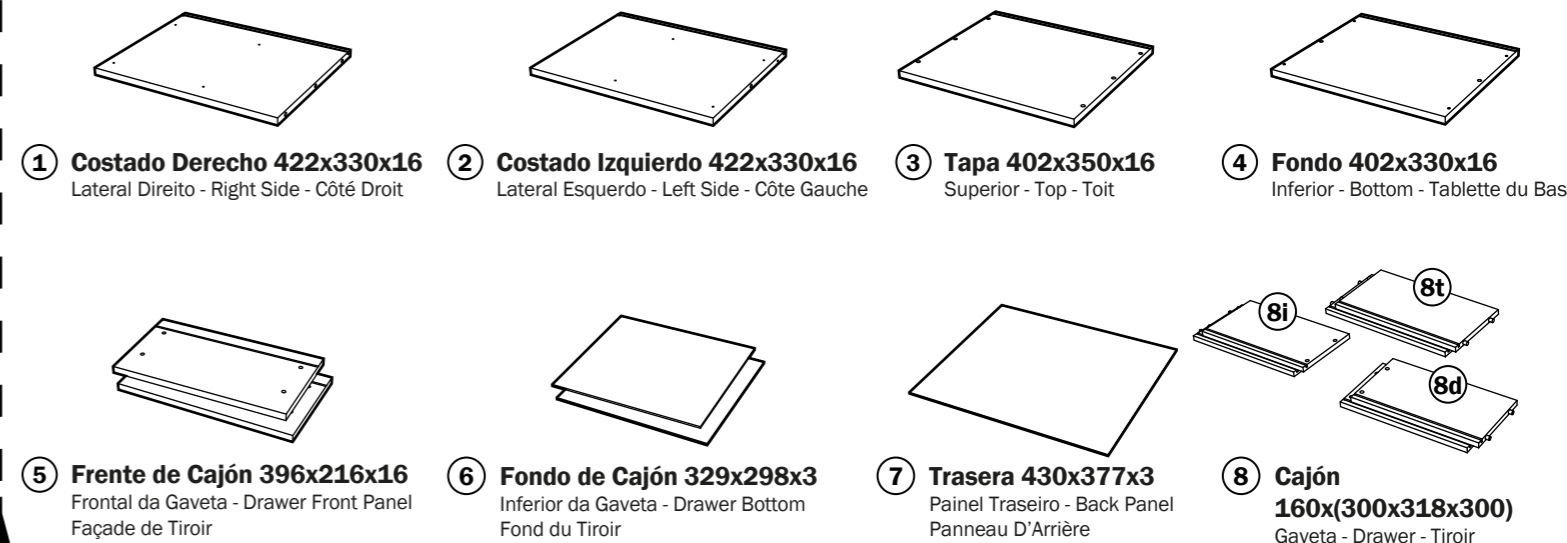

1

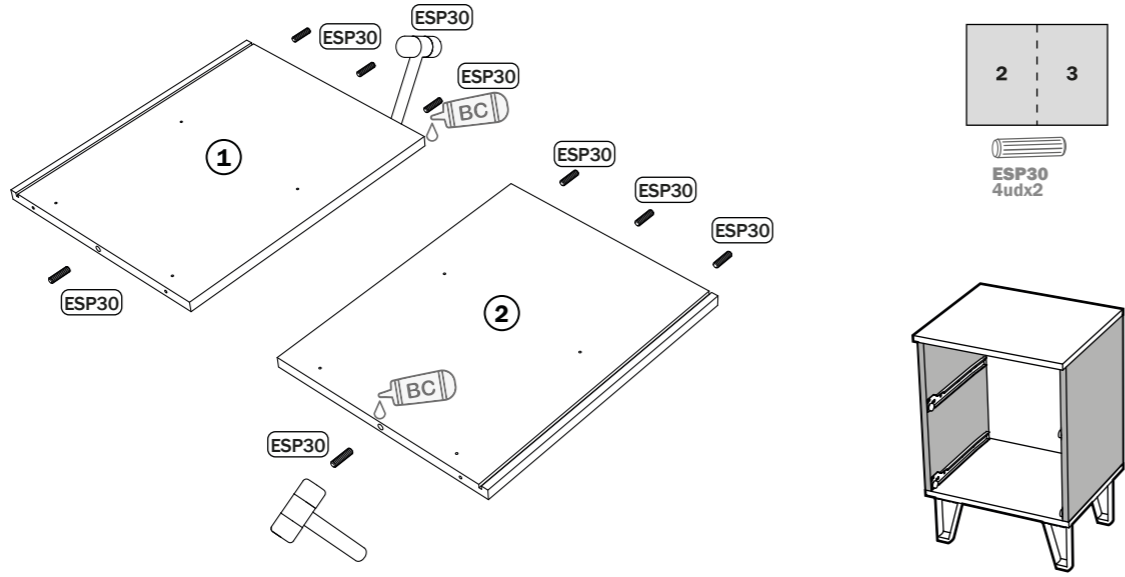

2

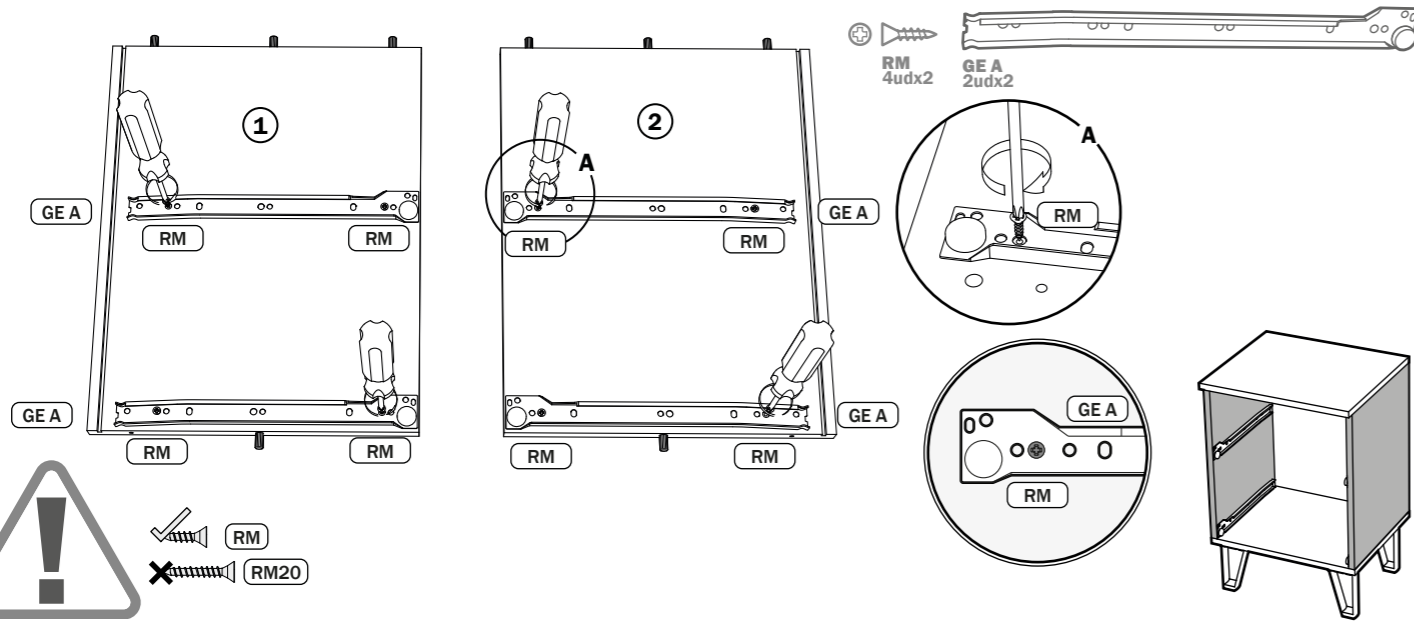

3

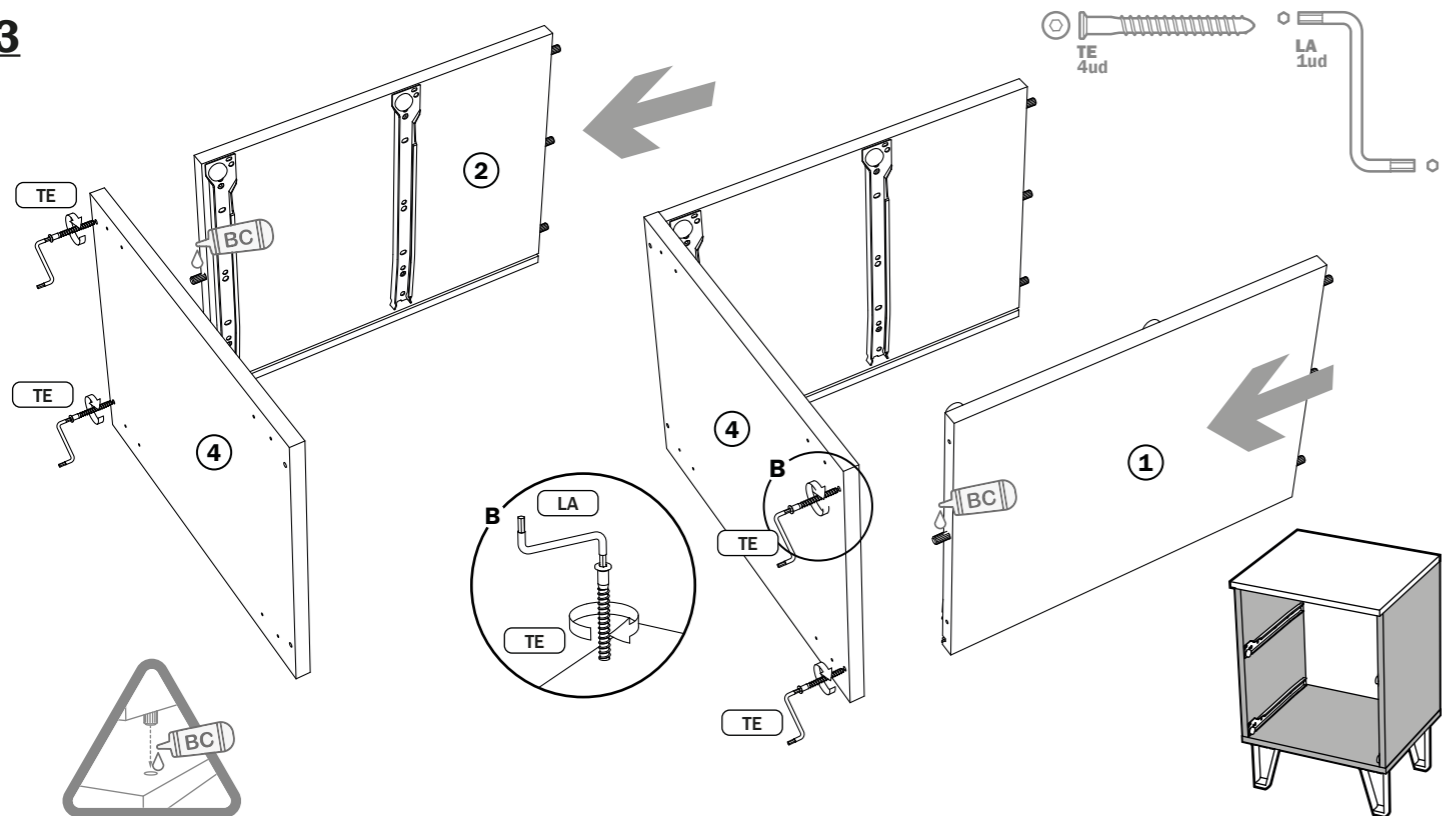

4

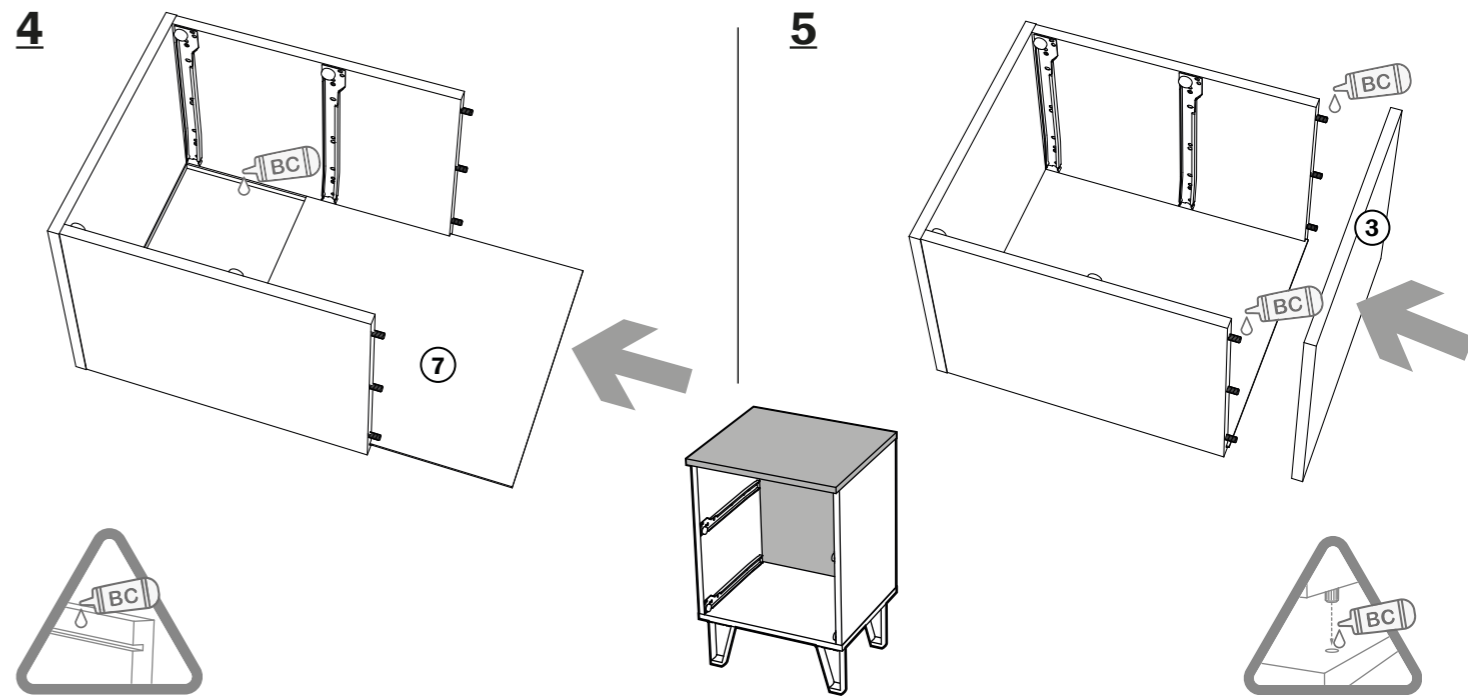

6

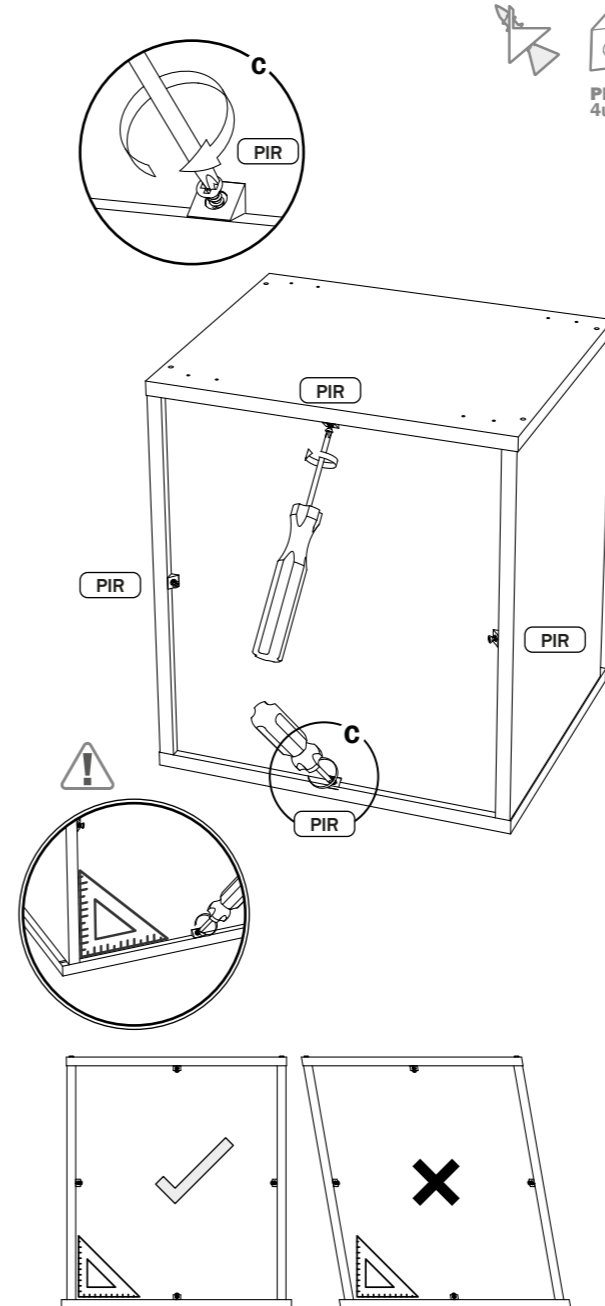

5

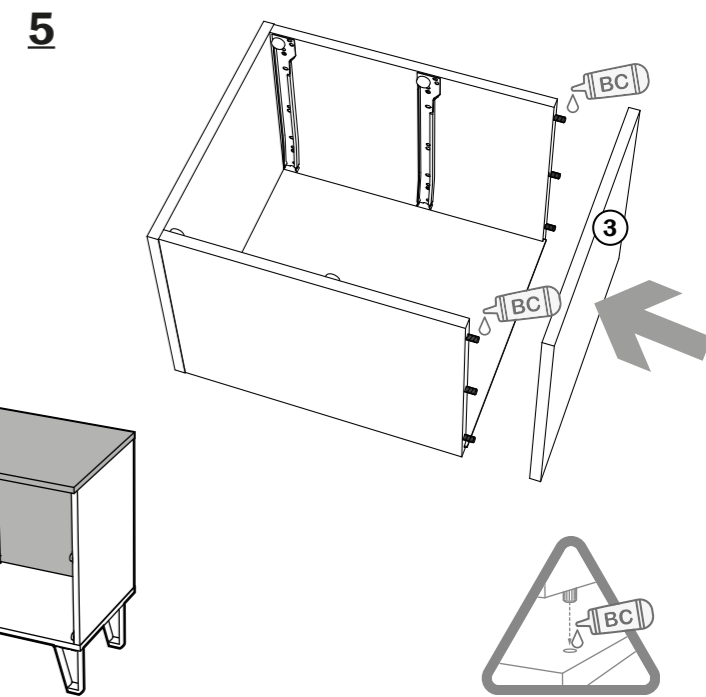

7

