

# Assembly Instructions / Instrucciones De Montaje

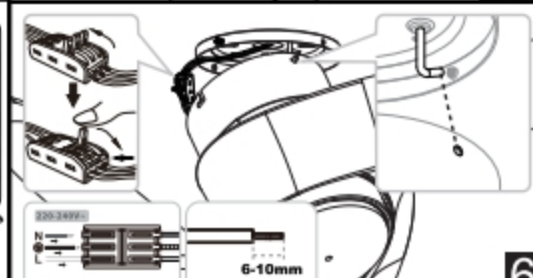

MOTOR 30W  
LED 24W 2700K-5000K 2640lm  
220-240V~50/60Hz

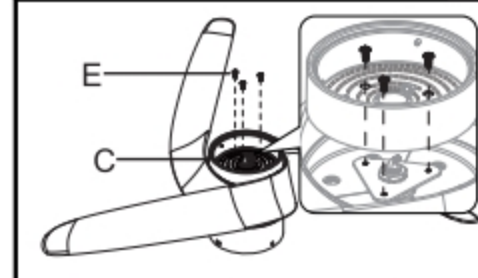
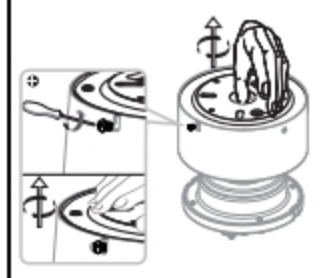
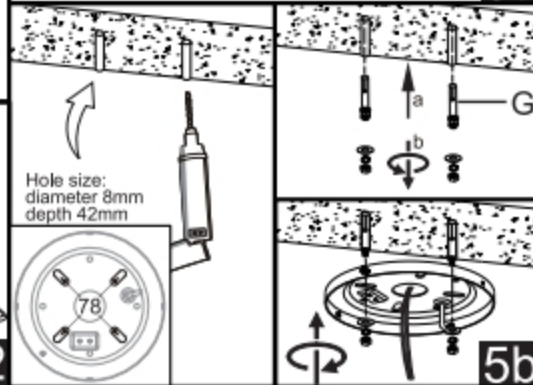
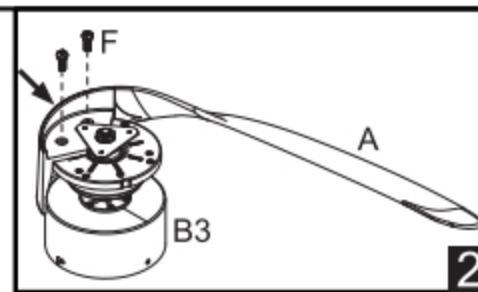
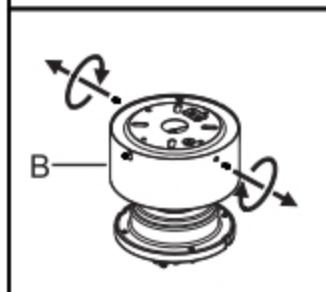
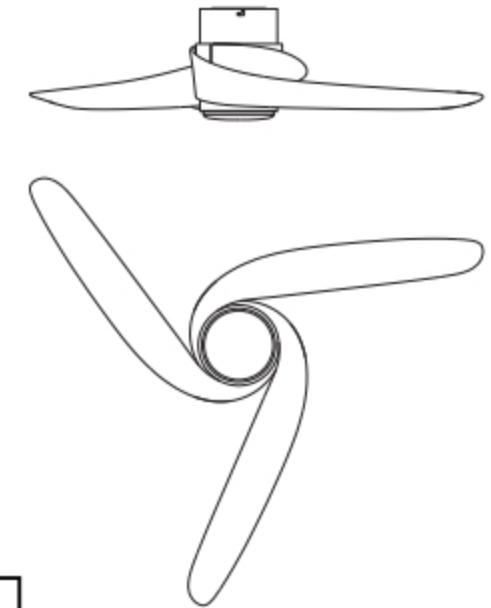
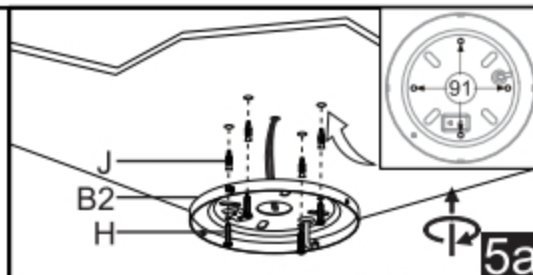
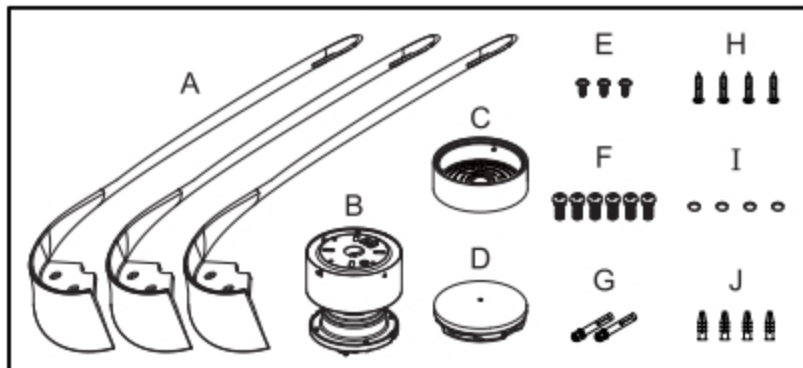

ES: Este producto contiene una fuente luminosa de la clase de eficiencia energética F.  
EN: This product contains a light source of energy efficiency class F.  
FR: Ce produit contient une source lumineuse de classe d'efficacité énergétique F.  
DE: Dieses Produkt enthält eine Lichtquelle der Energieeffizienzklasse F.  
IT: Questo prodotto contiene una sorgente luminosa di classe di efficienza energetica F.  
NL: Dit product bevat een lichtbron van energie-efficiëntieklasse F.  
SV: Denna produkt innehåller en ljuskälla av energieeffektivitetsklass F.  
CZ: Tento výrobek obsahuje světelný zdroj třídy energetické účinnosti F.  
SK: Tento výrobok obsahuje svetelný zdroj triedy energetickej účinnosti F.  
RO: Acest produs conține o sursă de lumină de clasă de eficiență energetică F.  
PT: Este produto contém uma fonte de luz de classe de eficiência energética F.

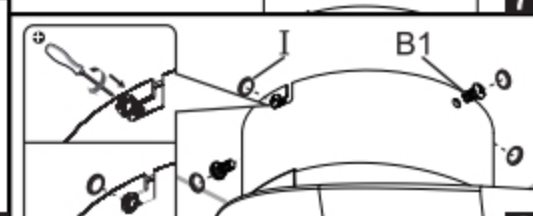
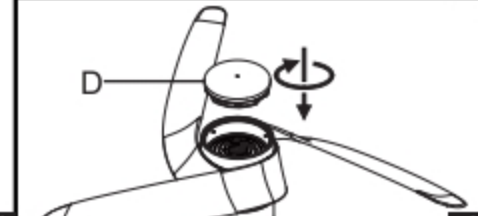
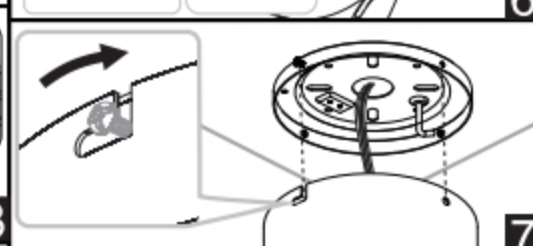
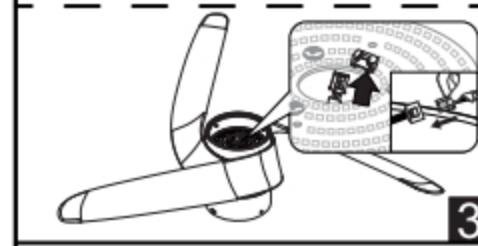
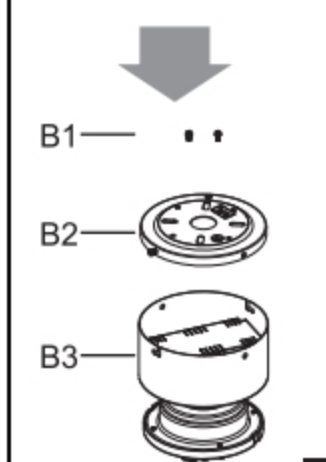

REF.:  
8708/8709/8710  
8711/8712/8713

mAntra

## INSTRUCCIONES MANDO A DISTANCIA

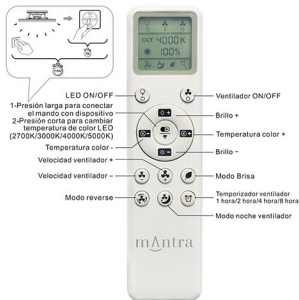

MANUAL REMOTE CONTROL



MANUAL APP mAntra Lighting

mAntra

## REMOTE CONTROLLER INSTRUCTION

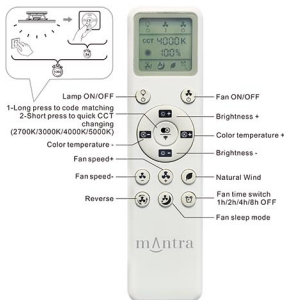

MANUAL REMOTE CONTROL



MANUAL APP mAntra Lighting

mAntra

## INSTRUCCIONES APP MANTRA LIGHTING

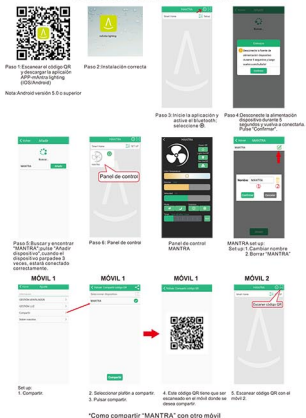

## MANTRA LIGHTING APP INSTRUCTION

