

REGISTER TODAY

We are so glad that you have joined us on the journey to barbecuing greatness. Register your barbecue and gain access to fun and engaging WEBER information, including tips, tricks and how to get the most out of your barbecuing experience.

Important Safety Information

DANGER, WARNING, and CAUTION statements are used throughout this Owner's Manual to emphasise critical and important information. Read and follow these statements to help ensure safety and prevent property damage. The statements are defined below.

- ⚠ **DANGER:** Indicates a hazardous situation which, if not avoided, *will result in death or serious injury.*
- ⚠ **WARNING:** Indicates a hazardous situation which, if not avoided, *could result in death or serious injury.*
- ⚠ **CAUTION:** Indicates a hazardous situation which, if not avoided, *could result in minor or moderate injury.*

USE OUTDOORS ONLY.

READ THE INSTRUCTIONS BEFORE USING THE APPLIANCE (BARBECUE).

NOTICE TO INSTALLER: These instructions must be left with the consumer.

NOTICE TO CONSUMER: Retain these instructions for future reference.

Important: Read these instructions carefully so as to familiarize yourself with the appliance before connecting it to its gas cartridge or gas cylinder. Keep these instructions for future reference.

⚠ DANGER

If you smell gas:

- **Shut off gas to the appliance (barbecue).**
- **Extinguish any open flame.**
- **Open lid.**
- **If odour continues, keep away from the appliance (barbecue) and immediately call your gas supplier or the emergency fire services.**

⚠ WARNING

- **Do not store or use gasoline or other flammable liquids or vapours in the vicinity of this (barbecue) or any other appliance.**
- **An LPG cylinder not connected for use shall not be stored in the vicinity of this (barbecue) or any other appliance.**

Installation and Assembly

- ⚠ **DANGER:** This barbecue is not intended to be installed in or on recreational vehicles or boats.
- ⚠ **WARNING:** Do not use this barbecue unless all parts are in place and the barbecue was properly assembled according to the assembly instructions.
- ⚠ **WARNING:** Do not build this model of barbecue in any built-in or slide-in construction.
- ⚠ **WARNING:** Do not modify the appliance. LPG is not natural gas. The conversion or attempted use of natural gas in an LPG gas unit or LPG gas in a natural gas unit is unsafe and will void your warranty.
- Any parts sealed by the manufacturer must not be altered by the user.

Operation

- ⚠ **DANGER:** Only use the barbecue outdoors in a well-ventilated area. Do not use in a garage, building, breezeway, tent, any other enclosed area, or beneath an overhead combustible structure.
- ⚠ **DANGER:** Do not use the barbecue in any vehicle or in any storage or cargo area of any vehicle. This includes, but is not limited to, cars, trucks, station wagons, mini-vans, sport utility vehicles, recreational vehicles, and boats.
- ⚠ **DANGER:** When in use, combustible materials should not be within 61 cm (24 inches) of the back or sides of the barbecue.
- ⚠ **DANGER:** Keep the cooking area clear of flammable vapours and liquids such as petrol, alcohol, etc., and combustible materials.
- ⚠ **DANGER:** This appliance must be kept away from flammable materials during use.
- ⚠ **DANGER:** Do not put a barbecue cover or anything flammable on, or in the storage area under the barbecue while it is in operation or is hot.
- ⚠ **DANGER:** Should a grease fire occur, turn off all burners and leave lid closed until fire is out.
- ⚠ **WARNING:** Accessible parts may be very hot. Keep young children away.
- ⚠ **WARNING:** The use of alcohol, prescription drugs, non-prescription drugs, or illegal drugs may impair the consumer's ability to properly and safely assemble, move, store, or operate the barbecue.
- ⚠ **WARNING:** Never leave the barbecue unattended during pre-heating or use. Exercise caution when using this barbecue. The entire cookbox gets hot when in use.
- ⚠ **WARNING:** Use heat-resistant barbecue mitts or gloves (conforming to EN 407, Contact Heat rating level 2 or greater) when operating barbecue.
- ⚠ **WARNING:** Do not move the appliance during use.
- ⚠ **WARNING:** Keep any electrical supply cord and the fuel supply hose away from any heated surfaces.
- ⚠ **CAUTION:** This product has been safety-tested and is only certified for use in a specific country. Refer to country designation located on outside of box.
- Do not use charcoal, briquettes or lava rock in the barbecue.



8652734

111323
enGB



SAFETY

Storage and/or Nonuse

- ⚠ **WARNING:** Turn off the gas supply at the gas cylinder after use.
- ⚠ **WARNING:** LPG cylinders must be stored outdoors out of the reach of children and must not be stored in a building, garage or any other enclosed space.
- ⚠ **WARNING:** After a period of storage and/or nonuse, the barbecue should be checked for gas leaks and burner obstructions before use.
- Storage of the barbecue indoors is permissible only if the LPG cylinder is disconnected and removed from the barbecue.

WARRANTY

- Thank you for purchasing a WEBER product. Weber-Stephen Products LLC, 1415 S. Roselle Road, Palatine, Illinois 60067 ("WEBER") prides itself on delivering a safe, durable, and reliable product.
- This is WEBER's Voluntary Warranty provided to you at no extra charge. It contains the information you will need to have your WEBER product repaired in the unlikely event of a failure or defect.
- Pursuant to applicable laws, the customer has several rights in case the product is defective. Those rights include supplementary performance or replacement, abatement of the purchasing price, and compensation. In the European Union, for example, this would be a two-year statutory warranty starting on the date of the handover of the product. These and other statutory rights remain unaffected by this warranty provision. In fact, this warranty grants additional rights to the Owner that are independent from statutory warranty provisions.

WEBER'S VOLUNTARY WARRANTY

- WEBER warrants, to the purchaser of the WEBER product (or in the case of a gift or promotional situation, the person for whom it was purchased as a gift or promotional item), that the WEBER product is free from defects in material and workmanship for the period(s) of time specified below when assembled and operated in accordance with the accompanying Owner's Manual. (Note: If you lose or misplace your WEBER Owner's Manual, a replacement is available online at www.weber.com, or such country-specific website to which Owner may be redirected.) Under normal, private single family home or apartment use and maintenance, WEBER agrees within the framework of this warranty to repair or replace defective parts within the applicable time periods, limitations, and exclusions listed below. TO THE EXTENT ALLOWABLE BY APPLICABLE LAW, THIS WARRANTY IS EXTENDED ONLY TO THE ORIGINAL PURCHASER AND IS NOT TRANSFERABLE TO SUBSEQUENT OWNERS, EXCEPT IN THE CASE OF GIFTS AND PROMOTIONAL ITEMS AS NOTED ABOVE.

OWNER'S RESPONSIBILITIES UNDER THIS WARRANTY

- To ensure trouble-free warranty coverage, it is important (but it is not required) that you register your WEBER product online at www.weber.com, or such country-specific website to which Owner may be redirected. Please also retain your original sales receipt and/or invoice. Registering your WEBER product confirms your warranty coverage and provides a direct link between you and WEBER in case we need to contact you.
- The above warranty only applies if the Owner takes reasonable care of the WEBER product by following all assembly instructions, usage instructions, and preventative maintenance as outlined in the accompanying Owner's Manual, unless the Owner can prove that the defect or failure is independent of non-compliance with the above mentioned obligations. If you live in a coastal area, or have your product located near a pool, maintenance includes regular washing and rinsing of the exterior surfaces as outlined in the accompanying Owner's Manual.

WARRANTY HANDLING / EXCLUSION OF WARRANTY

- If you believe that you have a part which is covered by this Warranty, please contact WEBER Customer Service using the contact information on our website (www.weber.com, or such country-specific website to which Owner may be redirected).
- WEBER will, upon investigation, repair or replace (at its option) a defective part that is covered by this Warranty. In the event that repair or replacement are not possible, WEBER may choose (at its option) to replace the grill in question with a new grill of equal or greater value. WEBER may ask you to return parts for inspection, shipping charges to be pre-paid.
- This WARRANTY lapses if there are damages, deteriorations, discolourations, and/or rust for which WEBER is not responsible caused by:
 - Abuse, misuse, alteration, modification, misapplication, vandalism, neglect, improper assembly or installation, and failure to properly perform normal and routine maintenance;
 - Insects (such as spiders) and rodents (such as squirrels), including but not limited to damage to burner tubes and/or gas hoses;
 - Exposure to salt air and/or chlorine sources such as swimming pools and hot tubs/spas;
 - Severe weather conditions such as hail, hurricanes, earthquakes, tsunamis or surges, tornadoes or severe storms.
- The use and/or installation of parts on your WEBER product that are not genuine WEBER parts will void this Warranty, and any damages that result hereby are not covered by this Warranty. Any conversion of a gas grill not authorised by WEBER and performed by a WEBER authorised service technician will void this Warranty.

PRODUCT WARRANTY PERIODS

Cookbox:	5 years, no rust through/burn through
Lid assembly:	5 years, no rust through/burn through
Stainless steel burner tube:	3 years, no rust through/burn through
Porcelain-enamelled cast iron cooking grates:	3 years, no rust through/burn through
Plastic components:	2 years, excluding fading or discoloration
All remaining parts:	2 years

DISCLAIMERS

APART FROM THE WARRANTY AND DISCLAIMERS AS DESCRIBED IN THIS WARRANTY STATEMENT, THERE ARE EXPLICITLY NO FURTHER WARRANTY OR VOLUNTARY DECLARATIONS OF LIABILITY GIVEN HERE WHICH GO BEYOND THE STATUTORY LIABILITY APPLYING TO WEBER. THE PRESENT WARRANTY STATEMENT ALSO DOES NOT LIMIT OR EXCLUDE SITUATIONS OR CLAIMS WHERE WEBER HAS MANDATORY LIABILITY AS PRESCRIBED BY STATUTE.

NO WARRANTIES SHALL APPLY AFTER THE APPLICABLE PERIODS OF THIS WARRANTY. NO OTHER WARRANTIES GIVEN BY ANY PERSON, INCLUDING A DEALER OR RETAILER, WITH RESPECT TO ANY PRODUCT (SUCH AS ANY "EXTENDED WARRANTIES"), SHALL BIND WEBER. THE EXCLUSIVE REMEDY OF THIS WARRANTY IS REPAIR OR REPLACEMENT OF THE PART OR PRODUCT.

IN NO EVENT UNDER THIS VOLUNTARY WARRANTY SHALL RECOVERY OF ANY KIND BE GREATER THAN THE AMOUNT OF THE PURCHASE PRICE OF THE WEBER PRODUCT SOLD.

YOU ASSUME THE RISK AND LIABILITY FOR LOSS, DAMAGE, OR INJURY TO YOU AND YOUR PROPERTY AND/OR TO OTHERS AND THEIR PROPERTY ARISING OUT OF THE MISUSE OR ABUSE OF THE PRODUCT OR FAILURE TO FOLLOW INSTRUCTIONS PROVIDED BY WEBER IN THE ACCOMPANYING OWNER'S MANUAL.

PARTS AND ACCESSORIES REPLACED UNDER THIS WARRANTY ARE WARRANTED ONLY FOR THE BALANCE OF THE ABOVE MENTIONED ORIGINAL WARRANTY PERIOD(S).

THIS WARRANTY APPLIES TO PRIVATE SINGLE FAMILY HOME OR APARTMENT USE ONLY AND DOES NOT APPLY TO WEBER GRILLS USED IN COMMERCIAL, COMMUNAL OR MULTI-UNIT SETTINGS SUCH AS RESTAURANTS, HOTELS, RESORTS, OR RENTAL PROPERTIES.

WEBER MAY FROM TIME TO TIME CHANGE THE DESIGN OF ITS PRODUCTS. NOTHING CONTAINED IN THIS WARRANTY SHALL BE CONSTRUED AS OBLIGATING WEBER TO INCORPORATE SUCH DESIGN CHANGES INTO PREVIOUSLY MANUFACTURED PRODUCTS, NOR SHALL SUCH CHANGES BE CONSTRUED AS AN ADMISSION THAT PREVIOUS DESIGNS WERE DEFECTIVE.

Refer to International Business Units list at the end of this Owner's Manual for additional contact information.



Parts List

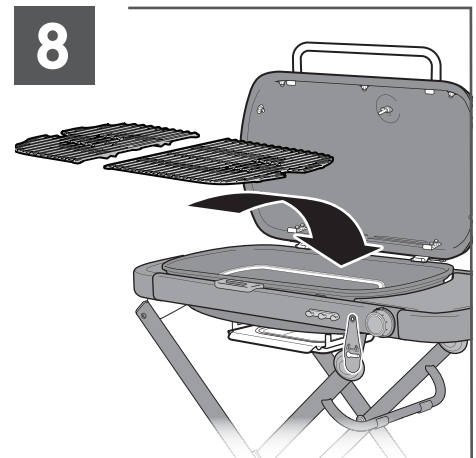
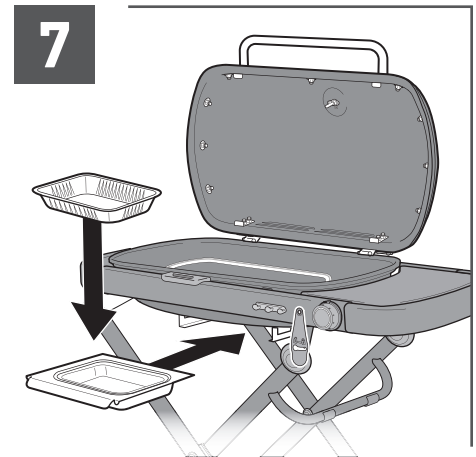
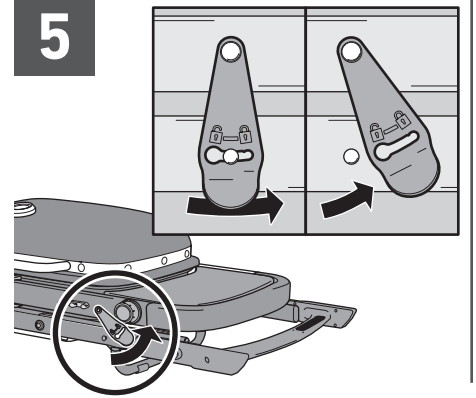
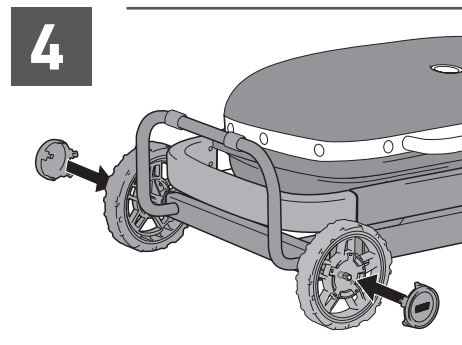
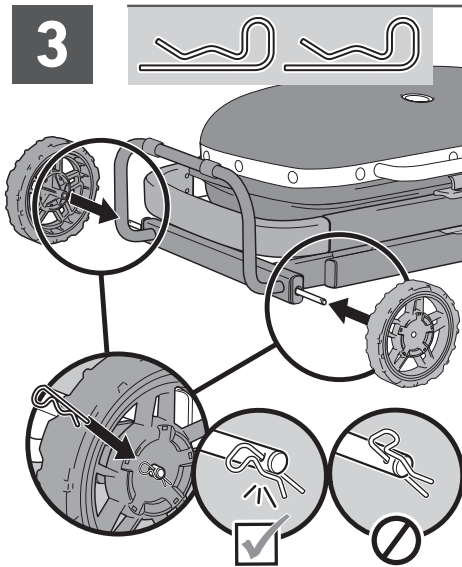
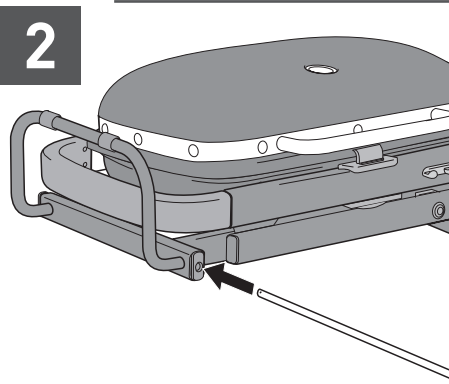
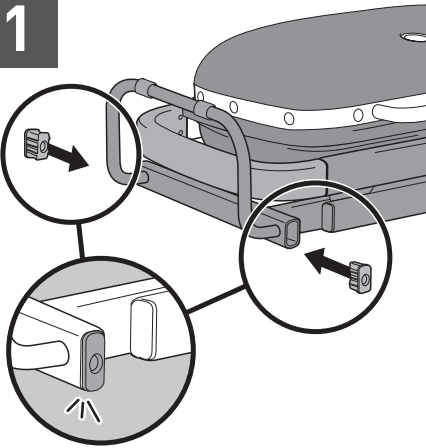
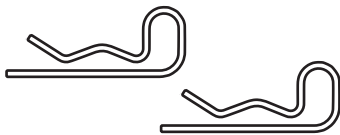
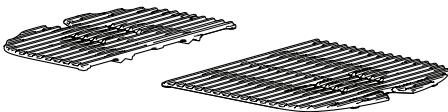
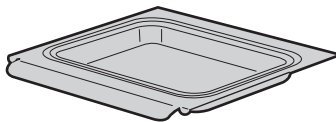
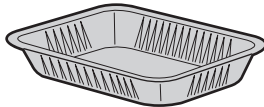
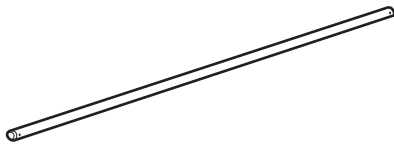
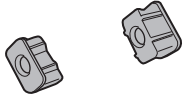
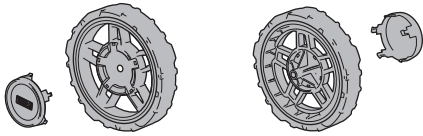

⚠ Remove all packaging materials and protective film before operating your barbecue.

The barbecues that are illustrated in this Owner's Manual may vary slightly from the model purchased.



PRODUCT FEATURES

Raising and Lowering the Barbecue

When it's time to set up or put away the barbecue, follow these steps to ensure the barbecue is ready.

Raising the Barbecue

- 1) Move the cart lock to the unlocked position and disengage it from the pin.
- 2) Stabilize the barbecue by keeping one foot on the foot stand (A) and lift the barbecue from the end of the side table frame (B) until it clicks into the raised position.

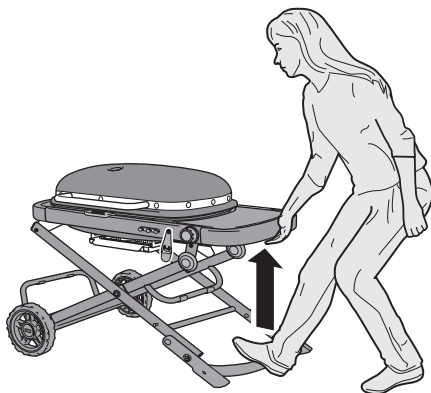
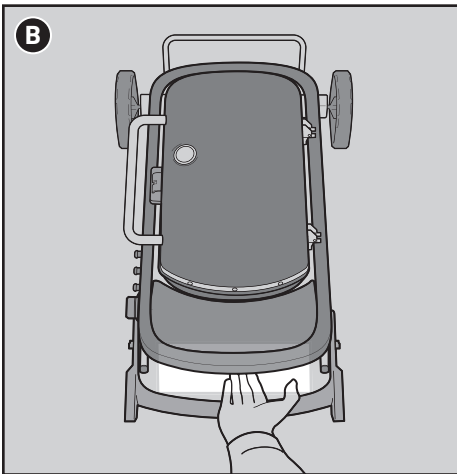
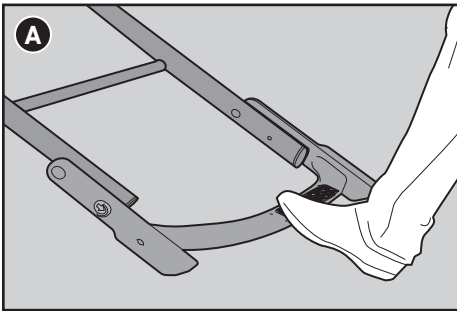
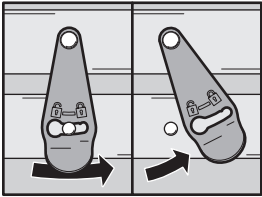

Lowering the Barbecue

- 1) Make sure the burner control knob is in the off (O) position.
- 2) Close the lid.
- 3) **Allow the barbecue to cool completely.**
- 4) **Remove the LPG cartridge.** by first turning off the regulator valve, then rotate the LP cartridge anticlockwise to disconnect it from the regulator. Refer to "Removing the Cartridge."
- 5) Always check the slide-out catch pan to clean or replace the disposable drip tray.
- 6) **To lower the cart,** make sure to keep one foot on the foot stand at the base of the barbecue and grasp the release lever on the back of the frame (a). Carefully disengage the release lever by: 1) pulling the lever toward you, and 2) lifting it up. Then, slowly lower the barbecue keeping your foot in place. **Important: Use caution when lowering the cart. Always guide the cart while moving to the down position by maintaining a steady grip on the frame. Repeated lowering of the cart without maintaining a grip on the frame may cause damage to the gas spring.**

Transportation and Storage

- 1) Once the cart is folded down, the automatic lid lock engages to keep the lid and cooking grates in place (b). To secure the cart in the folded position, fasten the cart lock over the pin (c) and move it to the locked position.
 - 2) After the cart is lowered and locked, the barbecue is ready to roll (d).
 - 3) For added convenience in the folded position, rotate the foot stand upward by first sliding back the red tabs on the side of the frame (e). This provides areas on both ends of the barbecue for lifting into storage or transportation.
- NOTE: Do not lift the barbecue by the lid handle.*
- 4) After a thorough cleaning, store the barbecue upright for a smaller footprint (f). Follow the steps in the "Cleaning and Maintenance" section of this owner's manual.

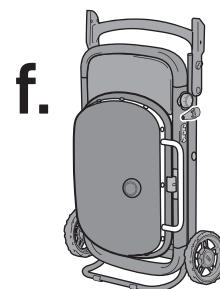
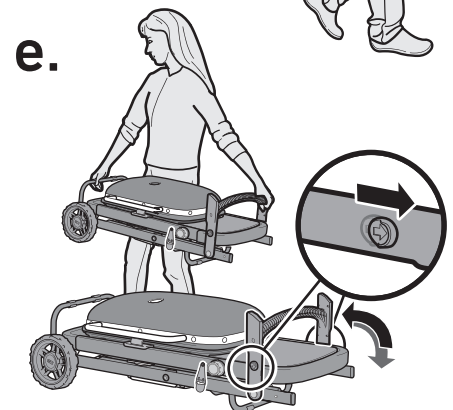
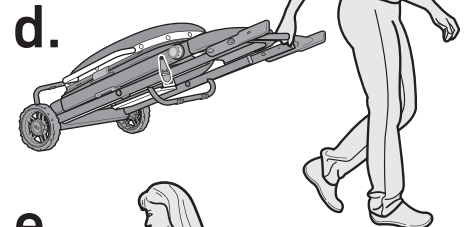
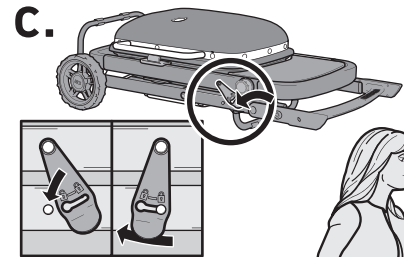
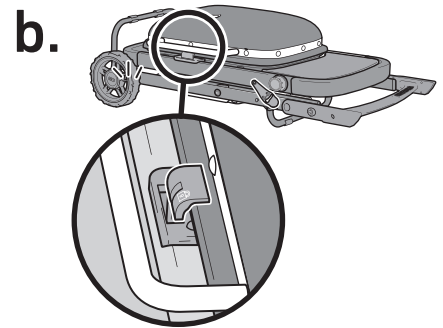

- ⚠ **WARNING:** Only set up the cart on a stable and level outdoor surface. Never set up the cart on a sloping surface.
- ⚠ **WARNING:** Use caution when removing slide-out catch pan and disposing of hot grease.
- ⚠ **WARNING:** Do not store the grill while the LP cylinder is attached.
- ⚠ **WARNING:** Do not store or transport a disconnected LP cylinder inside the grill.
- ⚠ **CAUTION:** Do not move the grill when in use. Allow the grill to cool before moving or storing.
- ⚠ **CAUTION:** Do not lift the grill by the lid handle as this could result in damage to the lid lock.
- ⚠ **CAUTION:** Do not stack additional items on grill during storage or transit.



Important Information about LP Gas & Gas Connections

What Is LP Gas?

Liquefied petroleum gas, also called LPG, LP gas, liquid propane, or simply propane or butane, is the flammable, petroleum-based product used to fuel your grill. It is a gas at moderate temperatures and pressure when it is not contained. But at moderate pressure inside a container, such as a tank, LP is a liquid. As pressure is released from the tank, the liquid readily vaporizes and becomes gas.

Safe Handling Tips for Disposable Cartridges

There are various guidelines and safety factors that you need to keep in mind when using LP gas. Carefully follow these instructions before using your gas grill.

- Do not use a damaged, dented or rusty cartridge.
- Although the cartridge may appear to be empty, gas may still be present, and the cartridge should be transported and stored accordingly.
- Cartridges should not be dropped or handled roughly.
- Never store or transport the cartridge where temperatures can reach 51° C (the cartridge will become too hot to hold by hand). For example: do not leave the cartridge in a car on a hot day.
- Cartridges must be kept out of reach of children.
- Leak-test the joint where the regulator connects to the cartridge each time a reconnection occurs. For example: test each time the cartridge is reinstalled.
- Leak-test the joint where the regulator connects to the cartridge each time a reconnection occurs. For example: test each time the cartridge is reinstalled.
- The areas around the cartridge must be free and clear from debris.
- The cartridge should not be changed in the proximity of an ignition source.
- Always close the regulator gas control valve before disconnecting regulator.

What is a Regulator?

Your gas barbecue is equipped with a pressure regulator, which is a device to control and maintain uniform gas pressure as gas is released from the LPG cylinder.

Regulator Connections

- In the United Kingdom, this barbecue must be fitted with a regulator complying with BS 3016, having a nominal output of 37 millibars.
- The length of the hose must not exceed 1.5 metres.
- Avoid kinking the hose.
- Change the flexible hose when national regulations stipulate this as a requirement.
- Any parts sealed by the manufacturer must not be altered by the user.
- Any modification of the appliance may be dangerous.

Installing the Cartridge

Use only butane/propane disposable cartridges with a minimum capacity of 430g and a maximum capacity of 460g. The cartridge must have an EN417 valve as illustrated (A).

Check that seals (between the appliance and the gas container) are in place and in good condition before connecting to the gas container (B).

- 1) Raise the grill.
- 2) Make sure burner control knob is turned off by pushing it in and turning it clockwise to the off (O) position.
- 3) Make sure the regulator gas control valve is turned off by turning clockwise until tight.
- 4) Push cartridge into regulator and turn clockwise until tight (C).

Removing the Cartridge

Every time you need to lower the grill cart, or if the cartridge is empty and needs to be replaced, follow these instructions to remove it.

- 1) Make sure burner control knob is turned off by pushing it in and turning it clockwise to the off (O) position.
- 2) Make sure the regulator gas control valve is turned off by turning clockwise until tight.
- 3) Unscrew the cartridge from the regulator by turning it anti-clockwise and remove it from the grill.

Storage and/or Travel

Disconnect the cartridge if: 1) the cartridge is empty; 2) the grill is being transported; 3) the grill is being stored in a garage or other enclosed area; 4) the grill is not in use.

- Do not store a disconnected cartridge in a building, garage, or any other enclosed area.
- Do not store or transport a disconnected cartridge inside the grill.

For grills that have been stored or left unused for a while, it is important to follow these guidelines:

- The WEBER gas grill should be checked for gas leaks and any obstructions in the burner tube before it is used. (Refer to "CHECKING FOR GAS LEAKS" and "ANNUAL MAINTENANCE.")
- Check that the areas under the cookbox and the removable catch pan are free from debris that might obstruct the flow of combustion or ventilation air.
- The spider/insect screen should also be checked for any obstructions. (Refer to "ANNUAL MAINTENANCE.")

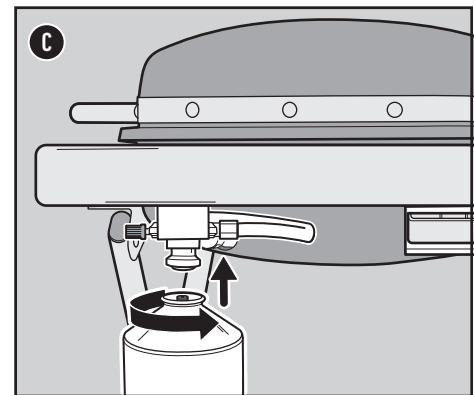
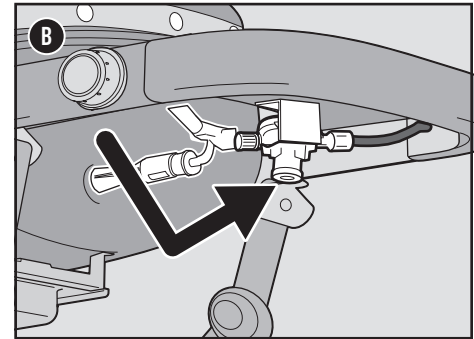
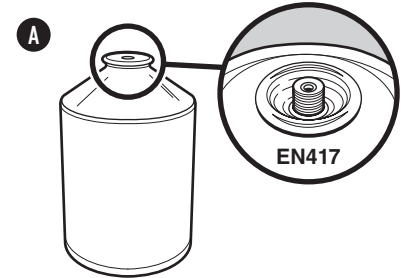
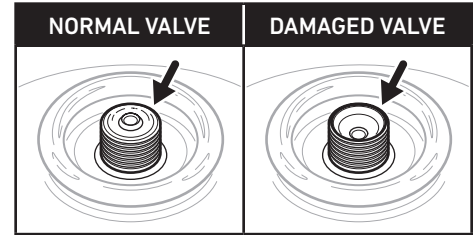

⚠ CAUTION: Only use WEBER Q Gas or other EN 417 cartridges marked 80% Butane/20% Propane.

⚠ WARNING: Hand tighten only. Using excessive force could damage the regulator coupling and cartridge valve. This could cause a leak or prevent gas flow

⚠ Check the seals before connecting a new gas container to the appliance.

⚠ Do not use the appliance if it has damaged or worn seals, is leaking, damaged or which does not operate properly.

⚠ Gas containers shall be changed in a well ventilated location, preferably outside, away from any sources of ignition, such as naked flames, pilots, electric fires and away from other people.



GETTING STARTED

What is a Leak Check?

Once the cartridge is properly installed, it is necessary to perform a leak check. A leak check is a reliable way to verify that gas is not escaping after you connect the tank. The fuel system in your grill features factory-made connections that have been thoroughly checked for gas leaks and the burners have been flame-tested. WEBER recommends performing a thorough leak check after assembly, as well as every time you disconnect and reconnect a gas fitting. The following fittings should be tested:

- Where the cartridge connects to the regulator.
- Where the regulator connects to the regulator hose.
- Where the regulator hose connects to the valve.

Checking for Gas Leaks

- 1) Make sure burner control knob is turned off by pushing it in and turning it clockwise to the off (O) position (A).
- 2) Turn gas supply on by turning the regulator gas control valve anti-clockwise (B).
- 3) Wet fittings (C) with a soap and water solution, using a spray bottle, brush, or rag. You can make your own soap and water solution by mixing 20% liquid soap with 80% water; or, you can purchase leak check solution in the plumbing section of any hardware store.
- 4) If bubbles appear there is a leak:
 - a) If the leak is at the cartridge (D), remove the cartridge. DO NOT OPERATE THE GRILL. Install a different cartridge and recheck for leaks with a soap and water solution. If the leak persists, remove the cartridge. DO NOT OPERATE THE GRILL. Contact the Customer Service Representative in your area using the contact information on our website.
 - b) If the leak is at the regulator (E) or burner valve (F), turn off the gas. NEVER ATTEMPT TO TIGHTEN THE REGULATOR. DO NOT OPERATE THE GRILL. Contact the Customer Service Representative in your area using the contact information on our website.

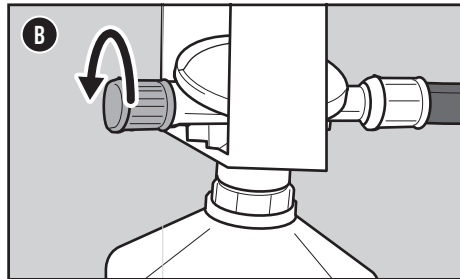
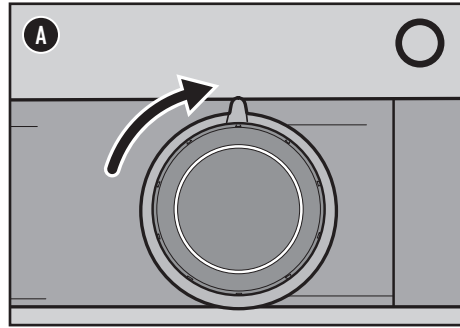

If a leak is present, contact the Customer Service Representative in your area using the contact information on our website.

- 5) If bubbles do not appear, leak checking is complete:
 - a) Rinse connections with water.

NOTE: Since some leak test solutions, including soap and water, may be slightly corrosive, all connections should be rinsed with water after checking for leaks.

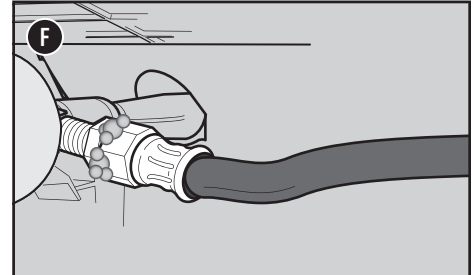
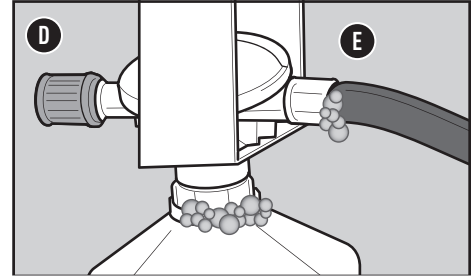
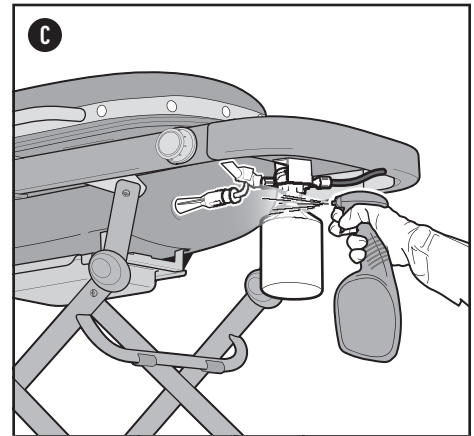

⚠ DANGER: Do not use a flame to check for gas leaks. Be sure there are no sparks or open flames in the area while you check for leaks.

⚠ DANGER: Leaking gas may cause a fire or explosion.

⚠ DANGER: Do not operate the grill if there is a gas leak present.

⚠ DANGER: If you see, smell, or hear the hiss of gas escaping from the liquid propane tank:

- 1) Move away from liquid propane tank.
- 2) Do not attempt to correct the problem yourself.
- 3) Call your fire department.

⚠ WARNING: It may be hazardous to attempt to fit other types of gas containers.

⚠ IMPORTANT: We recommend that you replace the gas hose assembly on your gas barbecue every five years. Some countries may have requirements that the gas hose be replaced within less than five years, in which case that country's requirement would take precedence.

For replacement hose, regulator, and valve assemblies, contact the Customer Service Representative in your area using the contact information on our web site.
Log on to weber.com.

Burner Injector Size and Consumption Data

WEBER TRAVELER COMPACT	INJECTOR SIZE	CONSUMPTION DATA
	Main Burner 0.93 mm	3.6 kW Butane 3.2 kW Propane
		258.0 g/h Butane 227.0 g/h Propane



The Very First Time You Barbecue

Perform an Initial Burn-Off

Heat the barbecue on the highest setting, with the lid closed, for at least 20 minutes prior to barbecuing for the first time.

Every Time You Barbecue

Meal-to-Meal Maintenance

The Meal-To-Meal Maintenance plan includes the following simple, yet important, steps that should always be performed prior to barbecuing.

Check for Grease

Your barbecue was built with a grease management system that funnels grease away from food and into a disposable container. As you cook, grease is channelled down to the slide-out catch pan and into a disposable drip tray that lines the catch pan. This system should be cleaned each and every time you barbecue to prevent fires.

- 1) Confirm that the barbecue is off and cool.
- 2) Remove the slide-out catch pan by pulling it forward (A).
- 3) Check for excessive amounts of grease in the disposable drip tray that lines the slide-out catch pan. Discard disposable drip pan when necessary and replace with a new one.
- 4) Reinstall all components.

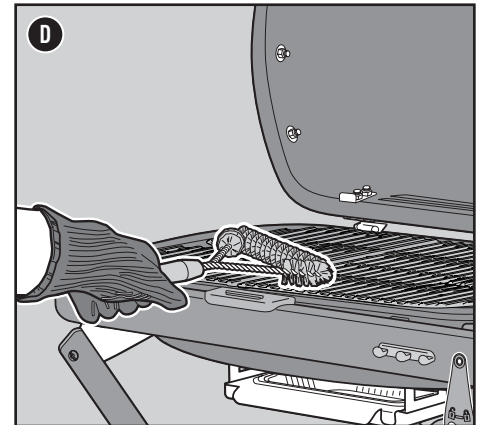
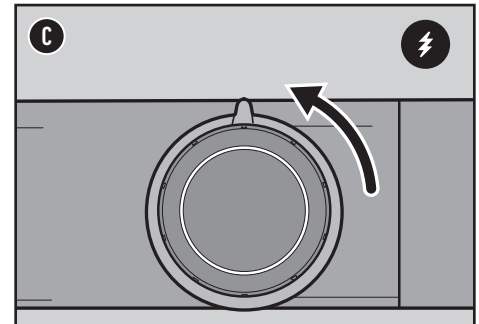
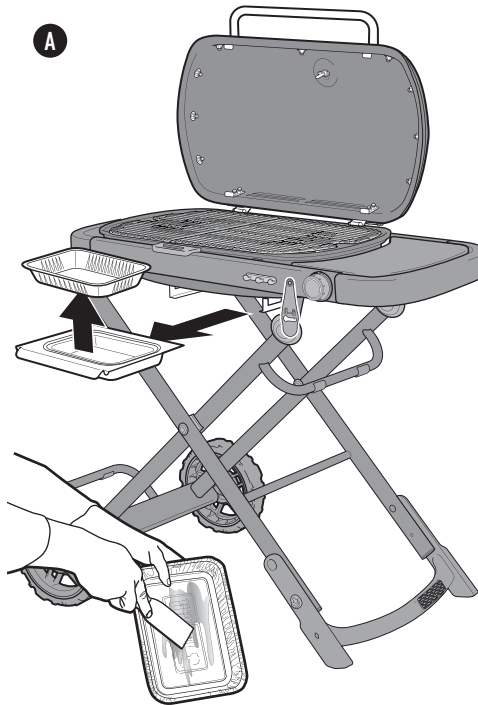

Inspect the Hose

Routine inspection of the hose is necessary.

- 1) Confirm that the barbecue is off and cool.
- 2) Check hose for any signs of cracking, abrasions, or cuts (B). If the hose is found to be damaged in any way, do not use the barbecue.

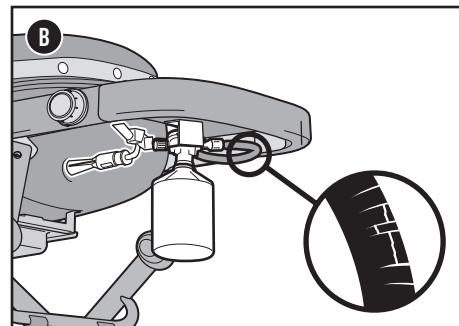

Preheat the Barbecue

Preheating the barbecue is critical to successful barbecuing. Preheating helps to prevent food from sticking to the grate and gets the grate hot enough to sear properly. It also burns off any residue from the previous meal.

- 1) Open the barbecue lid.
- 2) Ignite your barbecue according to the ignition instructions in this Owner's Manual.
- 3) Close lid.
- 4) Preheat the barbecue with all burners on the start/high 🔥 position for 10 to 15 minutes or until the thermometer shows 260°C (500°F) (C).

Clean the Cooking Grate

After preheating, any bits of food or debris left over from previous use will be easier to remove. Cleaned grates will also prevent your next meal from sticking.

- 1) Brush the grates with a stainless steel bristle barbecue brush immediately after preheating (D).

⚠️ **DANGER:** Do not line the slide-out catch pan or cookbox with aluminium foil.

⚠️ **DANGER:** Check the slide-out catch pan for grease build-up before each use. Remove excess grease to avoid a grease fire.

⚠️ **WARNING:** Use caution when removing catch pan and disposing of hot grease.

⚠️ **WARNING:** Use heat-resistant barbecue mitts or gloves (conforming to EN 407, Contact Heat rating level 2 or greater) when operating barbecue.

⚠️ **WARNING:** Barbecue brushes should be checked for loose bristles and excessive wear on a regular basis. Replace brush if any loose bristles are found on cooking grates or brush. WEBER recommends purchasing a new stainless steel bristle barbecue brush at the beginning of every spring.

⚠️ **WARNING:** If the hose is found to be damaged in any way, do not use the barbecue. Replace using only WEBER authorised replacement hose.

⚠️ **WARNING:** Keep ventilation openings around tank clear and free of debris.



OPERATION

Igniting the Barbecue

Using the Ignition System to Ignite the Barbecue

The ignition system ignites the burner with a spark from the igniter electrode. You generate the energy for the spark by pushing and turning the control knob to the start/high **⚡** position. You will hear the igniter click. After preheating on high is complete, you may adjust the burner control knob to your desired setting for barbecuing.

- 1) Open the barbecue lid (A).
- 2) Check that the burner control knob is in the off **○** position. Check by pushing in and turning knob clockwise (B).
- 3) Turn gas supply on by turning the regulator gas control valve anti-clockwise (C).
- 4) Push the burner control knob in and turn it counterclockwise to the start/high **⚡** position. You will hear the igniter click (D).
- 5) Check that the burner is lit by looking through the cooking grates. You should see a flame.
- 6) If the burner does not ignite, turn burner control knob to the off **○** position and wait five minutes to allow the gas to clear before attempting to light the burner again.

Should the burner fail to ignite using the ignition system, refer to the TROUBLESHOOTING section. There you will find instructions on igniting the barbecue with a match to help determine the exact problem.

To Extinguish Burners

- 1) Push the burner control knob in and then turn clockwise all the way to the off **○** position.

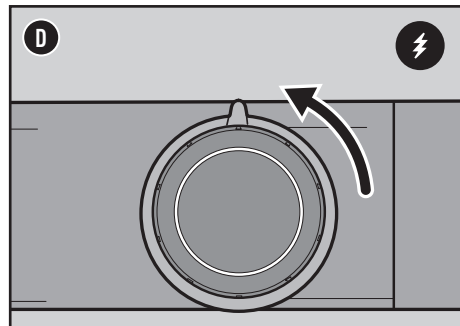
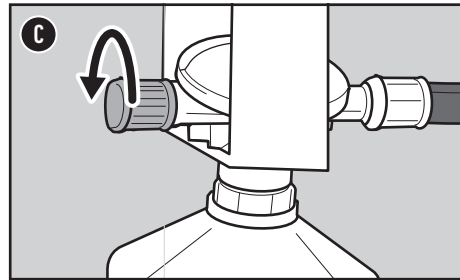
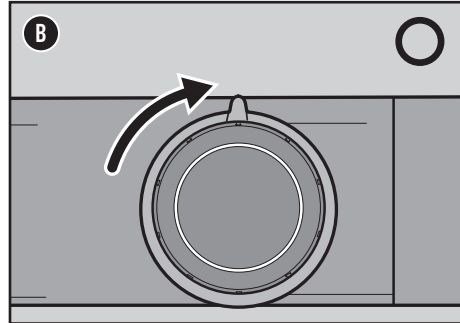
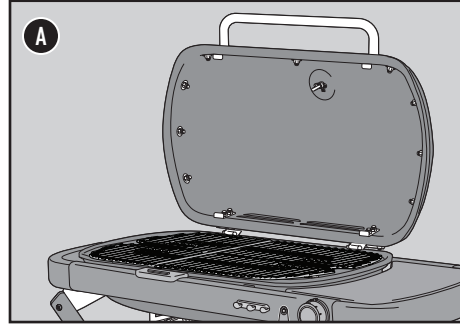

⚠ **WARNING:** Open lid during ignition.

⚠ **WARNING:** Do not lean over open grill while igniting or cooking.

⚠ **WARNING:** If ignition does not occur within five seconds, turn the burner control knob to the off position. Wait five minutes to allow accumulated gas to dissipate, and then repeat the lighting procedure.

Cleaning and Maintenance

Cleaning the Inside of the Grill

Over time, the performance of your grill can diminish if it has not been maintained properly. Low temperatures, uneven heat, and food sticking to cooking grates are all signs that cleaning and maintenance are overdue.

A thorough cleaning is recommended when the grill is going to be folded and stored vertically, or at least twice a year. Consistent use may require quarterly cleanings. When your grill is off and cool, start by cleaning the inside, from the top down.

Cleaning the Lid

From time to time you may notice "paint-like" flakes on the inside of the lid. During use, grease and smoke vapors slowly change into carbon and deposit on the inside of your lid. These deposits will eventually peel, and look very similar to paint. These deposits are non-toxic, but the flakes could fall onto your food if you do not clean the lid regularly.

- 1) Brush the carbonized grease from the inside of the lid with a stainless steel bristle grill brush (A). To minimize further build-up, the inside of the lid can be wiped with a paper towel after grilling while the grill is still warm (not hot).

Cleaning the Cooking Grates

If you have been cleaning your cooking grates as recommended, the debris on your grates should be minimal.

- 1) With grates installed, brush the debris off your cooking grate with a stainless steel bristle grill brush (B).
- 2) Take the grates out and set aside.

Cleaning the Burner

Two areas on the burner that are key to optimum performance are the ports (small openings running along the length of the burner) and the spider/insect screens on the ends of the burner. Keeping these areas clean is essential for safe operation.

Cleaning the Burner Ports

- 1) Use a clean stainless steel bristle grill brush to clean the outside of the burners by brushing across the top of the burner ports (C). Do not brush lengthwise, along the tube, as this will only brush debris from one port to another.
- 2) When cleaning the burner, avoid damaging the ignition electrode by carefully brushing around it.

Cleaning the Spider Screens

- 1) Locate the end of the burner behind the control panel where it meets the valve (D).
- 2) Clean the spider/insect screen on the burner using a soft bristle brush (E).



Cleaning the Cookbox

Look inside the cookbox for any grease accumulation or leftover food particles. Excessive accumulation can cause a fire.

- 1) Use a plastic scraper to scrape debris off the sides and bottom of the grill into the opening in bottom of the cookbox (F). This opening leads debris into the slide-out catch pan.

Cleaning the Grease Management System

The grease management system consists of a slide-out catch pan and a disposable drip tray (G). These components were designed to be easily removed, cleaned, and replaced; an essential step every time you prepare to grill. Instructions on inspecting the grease management system can be found in MEAL-TO-MEAL MAINTENANCE.

Cleaning the Outside of the Grill

The outside of your grill may include stainless steel, porcelain-enameled, and plastic surfaces. WEBER recommends the following methods based on the surface type.

Cleaning Stainless Steel Surfaces

Clean stainless steel using a non-toxic, non-abrasive stainless steel cleaner or polish designed for use on outdoor products and grills. Use a microfiber cloth to clean in the direction of the grain of the stainless steel. Do not use paper towels.

Note: Do not risk scratching your stainless steel with abrasive pastes. Pastes do not clean or polish. They will change the color of the metal by removing the top chromium oxide film coating.

Cleaning Painted, Porcelain-Enameled Surfaces and Plastic Components

Clean painted, porcelain-enameled and plastic components with warm soapy water, and paper towels or cloth. After wiping down the surfaces, rinse and dry thoroughly.

Cleaning the Outside of Grills that are in Unique Environments

If your grill is subject to a particularly harsh environment, you will want to clean the outside more often. Acid rain, pool chemicals, and salt water can cause surface rusting to appear. Wipe down the outside of your grill with warm soapy water. Follow up with a rinse and thorough drying. Additionally, you may want to apply a stainless steel cleaner weekly to prevent surface rust.

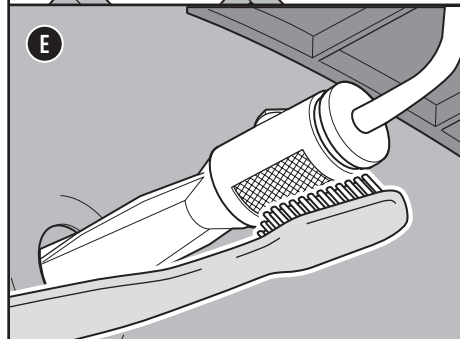
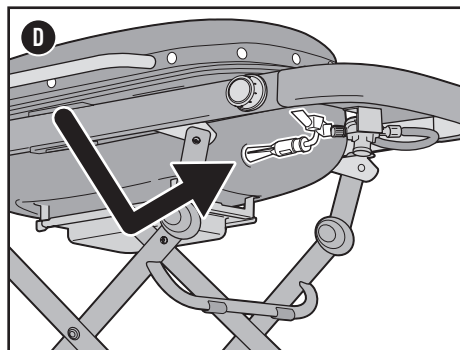
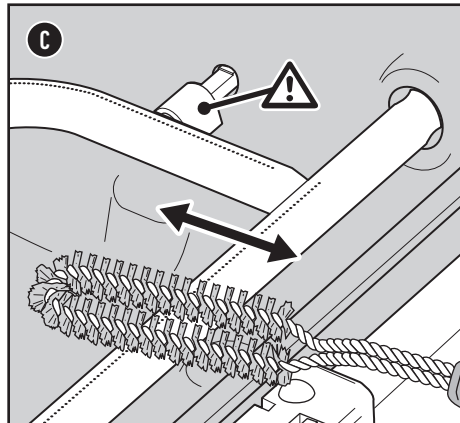
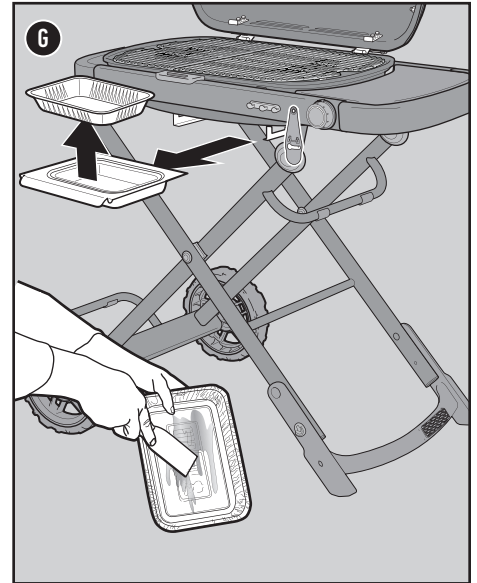
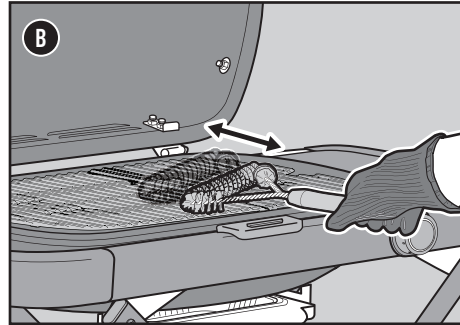
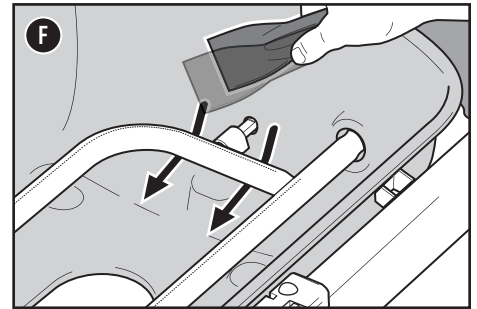
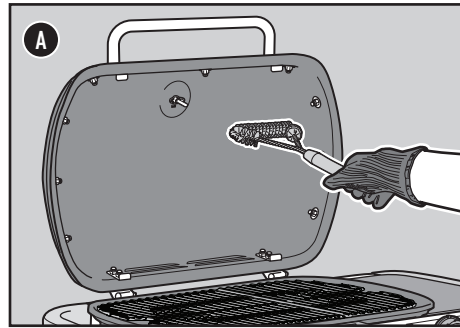

⚠ **WARNING:** Turn your grill off and wait for it to cool before thoroughly cleaning.

⚠ **WARNING:** When cleaning the burners, never use a brush that has already been used to clean the cooking grates. Never put sharp objects into the burner port holes.

⚠ **CAUTION:** Do not place any grill components onto the side tables as they may scratch the paint or stainless steel surfaces.

⚠ **CAUTION:** Do not use any of the following to clean your grill: abrasive stainless steel polishes or paints, cleaners that contain acid, mineral spirits or xylene, oven cleaner, abrasive cleansers (kitchen cleansers), or abrasive cleaning pads.



TROUBLESHOOTING

GRILL WILL NOT IGNITE

SYMPTOM

- Burner does not ignite when following the ignition instructions in the “Operation” section of this Owner’s Manual.

CAUSE	SOLUTION
There is a problem with gas flow.	If the grill will not ignite, the first step is to determine if there is gas flowing to the burners. To check this, follow the instructions below for “Using a Match to Determine if there is Gas Flow to the Burners.” If match lighting IS NOT successful , follow the gas flow troubleshooting suggestions on the next page.
There is a problem with the ignition system.	If the grill will not ignite, the first step is to determine if there is gas flowing to the burners. To check this, follow the instructions below for “Using a Match to Determine if there is Gas Flow to the Burners.” If match lighting IS successful , follow the instructions below for “Checking the Components of the Ignition System.”

Using a Match to Determine if there is Gas Flow to the Burners

- 1) Open the grill lid.
- 2) Check that the burner control knob is in the off ○ position. Check by pushing in and turning knobs clockwise.
- 3) Turn gas supply on by turning the regulator gas control valve anti-clockwise.
- 4) Strike a match and put the flame under the matchlight hole (A).
- 5) While holding lit match, push the burner control knob in and turn it counterclockwise to the start/high 🔊 position.
- 6) Check that the burner is lit by looking through the cooking grates.
- 7) If the burner does not ignite within 4 seconds, turn burner control knob to the off ○ position and wait five minutes to allow the gas to clear before attempting to light the burner again. If repeated attempts fail, follow the gas flow troubleshooting instructions on the next page.
- 8) If the burner ignites, the problem lies in the ignition system. Follow the instructions for “Checking the Components of the Ignition System.”

Checking the Components of the Ignition System

When turning the burner control knob counterclockwise to the start/high 🔊 position, you should hear it click. Check the wire to ensure the igniter is creating a spark.

Checking the Wire

- 1) Check that the black ignition wire is connected securely to the terminals behind the control panel (B).
- 2) Verify the burner control knob pushes in, rotates, clicks, and returns out again.
- 3) Push the burner control knob in and then turn clockwise all the way to the off ○ position.
If the grill will not ignite, contact the Customer Service Representative in your area using the contact information on our website.

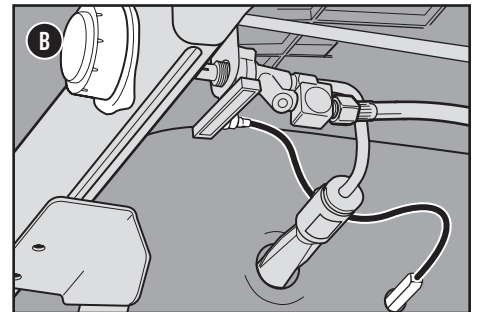
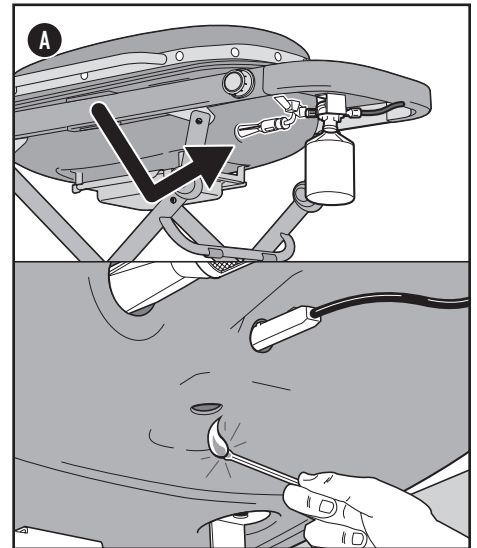

REPLACEMENT PARTS

To obtain replacement parts, contact the local retailer in your area or log onto weber.com.

CALL CUSTOMER SERVICE

If you are still experiencing any problems, contact the Customer Service Representative in your area using the contact information on weber.com.



GAS FLOW

SYMPTOM

- Grill does not reach desired temperature or heats unevenly.
- The burner fails to ignite.
- Flame is low when burner is on high position.
- Flames do not run the whole length of the burner.
- Burner flame pattern is erratic.

CAUSE

The LP cylinder is low or empty.
Burner ports are dirty.

SOLUTION

Replace LP cylinder.
Clean burner ports. Refer to "Cleaning the Burner Ports."

SYMPTOM

- Gas is smelled in conjunction with burner flames that appear yellow and lazy.

CAUSE

Spider screens on the burner is obstructed.

SOLUTION

Clean spider screens. Refer to "Cleaning the Spider Screens" in the Product Care section. Also refer to the illustrations and information in this section about proper flame pattern and spider screens.

SYMPTOM

- The smell of gas and/or a light hissing sound.

CAUSE

Connection between regulator and LP cylinder could be incomplete.
The regulator coupling with the LP cylinder could be damaged.

SOLUTION

Extinguish any open flame. Remove and reinstall the LP Cylinder. Refer to "Installing the LP Cylinder" section of your owner's manual.
Extinguish any open flame. Remove the LP cylinder. DO NOT OPERATE THE GRILL. Contact the Customer Service Representative in your area using the contact information on our website.

GREASY GRILL (Peeling Paint & Flare-Ups)

SYMPTOM

- Inside of lid appears to have the appearance of peeling paint.

CAUSE

The flakes you see are accumulated cooking vapors that have turned into carbon.

SOLUTION

This happens over time after repeated use of your grill. This is not a defect. Clean the lid. Refer to the "Product Care" section.

SYMPTOM

- Experiencing flare-ups when grilling or preheating.

CAUSE

There is leftover food from the previous meal.
The inside of the grill needs to be cleaned thoroughly.

SOLUTION

Always preheat the grill on the highest setting for 10 to 15 minutes.
Follow the steps in the "Cleaning and Maintenance" section to clean the grill inside from the top down.

Proper Burner Flame Pattern

The burner in your grill is factory set for the correct air and gas mixture. When the burner is performing correctly, you will see a specific flame pattern. The tips may occasionally flicker yellow (A), with a descending light blue (B) to dark blue flame (C).

⚠ WARNING: Blocked and dirty ports can restrict full gas flow, resulting in a fire (D) in and around the gas valves, causing serious damage to your grill.

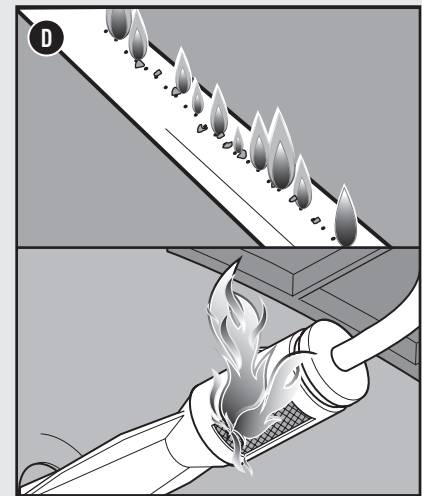
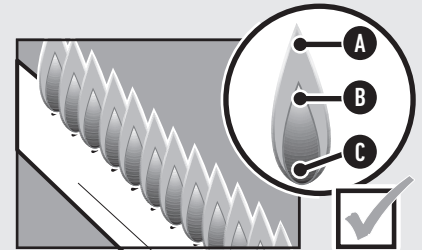

Spider Screens

The combustion air openings of the burners (E) are fitted with stainless steel screens to prevent spiders and other insects from spinning webs and building nests inside the venturi section of the burners. These nests can obstruct the normal gas flow, and can cause gas to flow back out of the combustion air opening. Symptoms of this kind of obstruction include the odour of gas in conjunction with burner flames that appear yellow and lazy. This obstruction could result in a fire in and around the gas valve, causing serious damage to your grill. Additionally, dust and debris can accumulate on the outside of the spider/insect screen and obstruct the oxygen flow to the burners. Keep the spider screens clean. Refer to "Cleaning the Spider Screens" in the Product Care section.

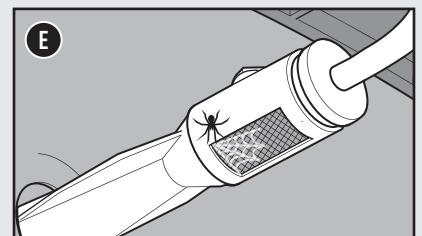

⚠ WARNING: Do not attempt to make any repair to gas carrying, gas burning, ignition components or structural components without contacting Weber-Stephen Products LLC, Customer Service Department.

⚠ CAUTION: The burner tube openings must be positioned properly over the valve orifices.



Manufacturer:

Weber-Stephen Products LLC

1415 S. Roselle Road
Palatine, IL 60067-6266
USA

Importer:

Weber-Stephen Products (EMEA) GmbH

Franklinstraße 28/29
10587 Berlin
Tel: (+49) 307554184-0

REPLACEMENT PARTS

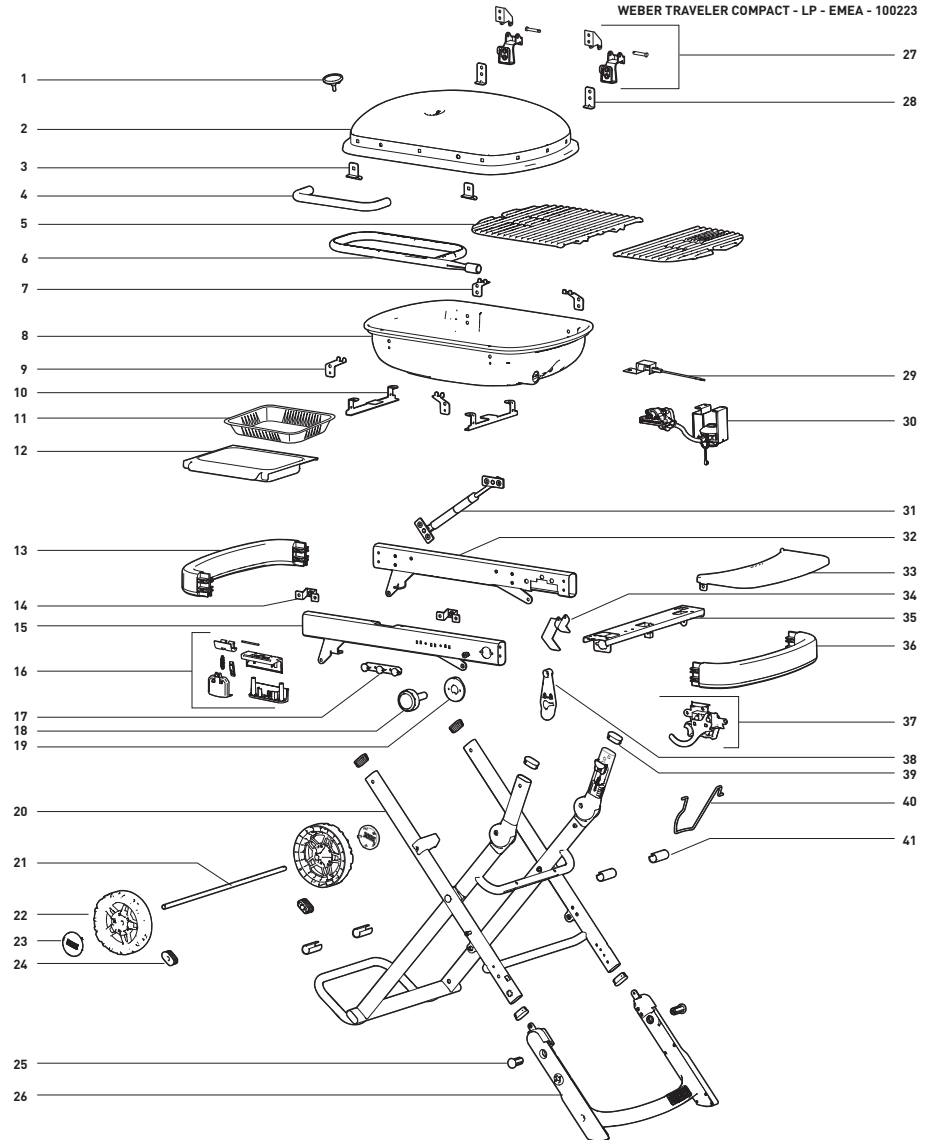

WEBER TRAVELER COMPACT - LP - EMEA - 100223

AUSTRIA

Weber-Stephen Österreich GmbH
+43 (0)7 242 89 0135
service-at@weber.com

BELGIUM

Weber-Stephen Products Belgium Sprl
+32 15 28 30 99
service-be@weber.com

CHILE

Weber-Stephen Chile SpA.
+01 56 2-3224-3936

CZECH REPUBLIC

Weber-Stephen CZ & SK spol. s r.o.
+42 267 312 973
info-cz@weberstephen.com

DENMARK

Weber-Stephen Nordic ApS
+45 99 36 30 10
service-dk@weber.com

FRANCE

Weber-Stephen France SAS
+33 0810 19 32 37
service-fr@weber.com

GERMANY

Weber-Stephen Deutschland GmbH
+49 (0) 30 219 0710
service-de@weber.com

ICELAND

Jarn & Gler Wholesale EHF
+354 58 58 900

INDIA

Weber-Stephen Grill Products India Pvt. Ltd.
080 42406666
customer-care@weberindia.com

ITALY

Weber-Stephen Products Italia Srl
+39 0444 367 911
service-it@weber.com

NETHERLANDS

Weber-Stephen Holland B.V.
+31 (0) 513 4 333 22
service-nl@weber.com

POLAND

Weber-Stephen Polska Sp. z o.o.
+48 22 392 04 69
info-pl@weberstephen.com

RUSSIA

Weber-Stephen Vostok LLC
+7 495 956 63 21
info.ru@weberstephen.com

SOUTH AFRICA

Weber-Stephen Products (South Africa) Pty Ltd.
+27 11 454 2369
info@weber.co.za

SPAIN

Weber-Stephen Ibérica SRL
+34 935 844 055
service-es@weber.com

SWITZERLAND

Weber-Stephen Schweiz GmbH
+41 52 24402 50
service-ch@weber.com

UNITED ARAB EMIRATES

Weber-Stephen Deutschland GmbH, Dubai Branch
+971 4 454 1626
info@weberstephen.ae

UNITED KINGDOM

Weber-Stephen Products (UK) Ltd.
+44 (0)203 630 1500
service-uk@weber.com

USA

Weber-Stephen Products LLC
847 934 5700
support@weberstephen.com

For Republic of Ireland, please contact:
Weber-Stephen Products (U.K.) Limited.

For other Eastern European countries, such as ROMANIA,
SLOVENIA, CROATIA or GREECE, please contact:
Weber-Stephen Deutschland GmbH.

For Baltic states, please contact:
Weber-Stephen Nordic ApS.