

No	Mould Ref	part designation	qty	raw material	Spec	source of raw material	% of recycled material	surface treatment	part net weight
1	YJLT-185B	armrest tube	2	Steel	40*14*0.7*395	TAIZHOU		powder coating	0.453
2	YJLT-035A	seat tube	1	Steel	Φ19*1.0*1335	TAIZHOU		powder coating	0.611
3	YJLT-035A	back tube	2	Steel	Φ19*1.0*560	TAIZHOU		powder coating	0.513
4	YJLT-035A	back top tube	1	Steel	Φ19*1.0*495	TAIZHOU		powder coating	0.226
5	YJLT-011A	front leg tube	2	Steel	28*14*0.9*585	TAIZHOU		powder coating	0.589
6	YJLT-010B	forefoot upper leghorizontal tube	1	Steel	25*11*0.8*510	TAIZHOU		powder coating	0.198
7	YJLT-010B	forefoot lower leghorizontal tube	1	Steel	25*11*0.8*495	TAIZHOU		powder coating	0.193
8	YJLT-011A	back leg tube	2	Steel	28*14*0.9*550	TAIZHOU		powder coating	0.554
9	YJLT-010B	back leg leghorizontal tube	1	Steel	25*11*0.8*550	TAIZHOU		powder coating	0.216

Rev	NAME	DATE
01		
02		
03		
04		
05		
06		



MATERIAU/FINISHING:

GENERAL TOLERANCES:
LINEAR:
ANGULAR:

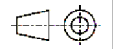

TITRE:
PROMO DINING SET TABLE 6P
150x80 CENTER UMB STEEL DARK GREY

No. DE PLAN: 3276007785098

A3
REVISION

ECHELLE: 1:1 (Scale can be adapted) Dimensions in mm FEUILLE 1 SUR 1

N°	Mould no	ADEO code	Description	Qty	Material	Size	Source of raw material	% of recycled material	surface treatment	part net weight
1	YJLT-108D	2025R09P12-0147	Table frame tube	1	Steel	34*15*1.1*4470	TAIZHOU		powder coating	2.14748
2	YJLT-036D	2025R09P12-0147	retaining ring	1	Steel	φ 22*0.9*2545	TAIZHOU		powder coating	1.19187
3	YJLT-063A	2025R09P12-0147	iron core	2	Steel	φ 7*225	TAIZHOU		powder coating	0.13595
4	YJLT-172A	2025R09P12-0147	upper leg tube	2	Steel	φ 24*0.9*365	TAIZHOU		powder coating	0.37428
5	YJLT-172A	2025R09P12-0147	leg tube	4	Steel	φ 24*0.9*960	TAIZHOU		powder coating	0.96881
6	YJLT-047C	2025R09P12-0147	iron lined tube	4	Steel	φ 20*1.0*415	TAIZHOU		powder coating	0.77783
7	MP-0467	2025R09P12-0147	adjusting knob	4	Copolymerization					

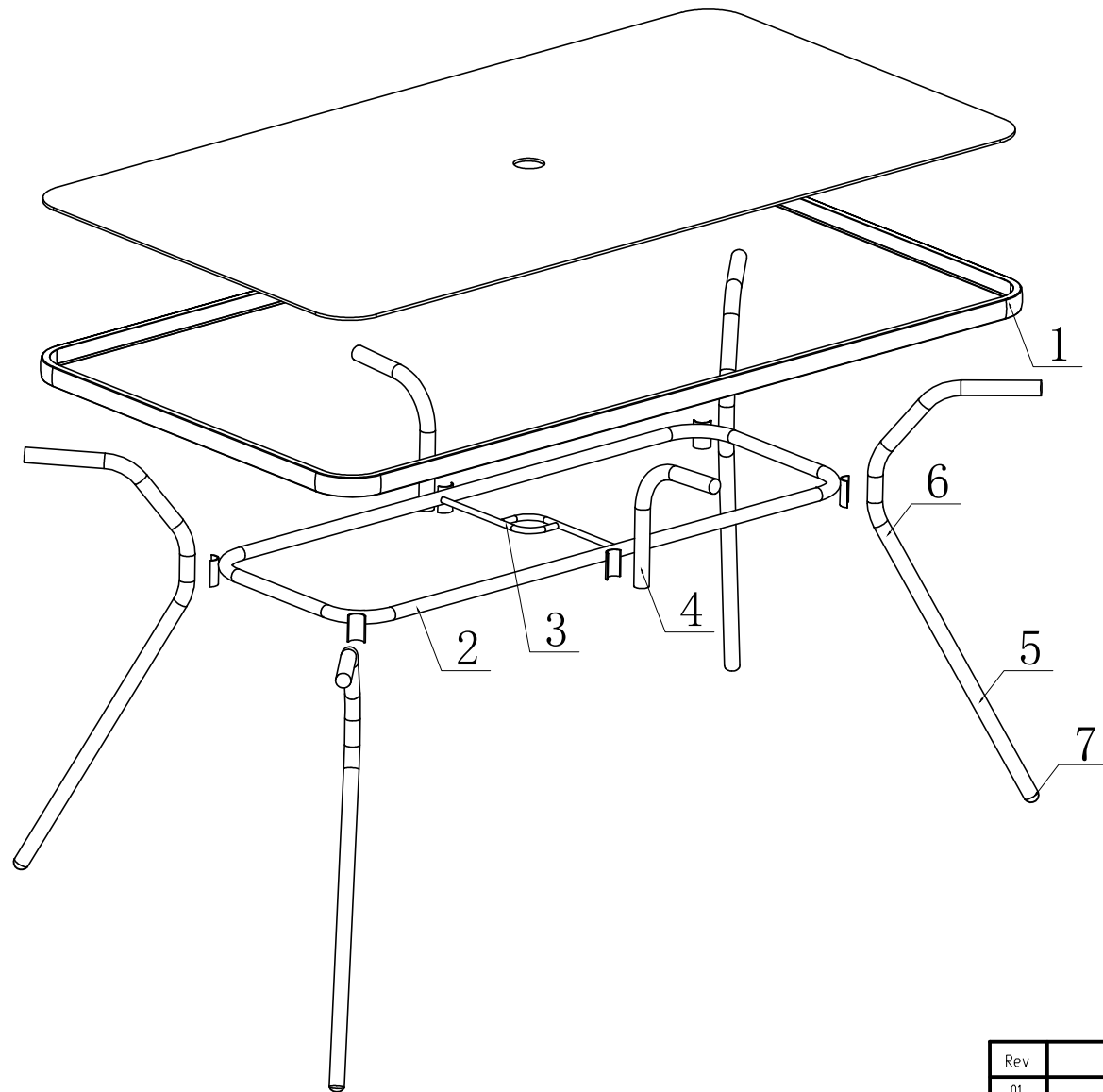

Rev	NAME	DATE
01		
02		
03		
04		
05		
06		

adeo
 ADED -135, rue Sadi Carnot
 CS 00001 - 59790 RONCHIN
 FRANCE

MATERIAU/FINISHING:

GENERAL TOLERANCES: LINEAR: ANGULAR:		
TITRE: PROMO DINING SET TABLE 6P 150x80 CENTER UMB STEEL DARK GREY		
No. DE PLAN	3276007785098	A3
ECHELLE: 1:1 (Scale can be adapted) Dimensions in mm		REVISION
		FEUILLE 1 SUR 1

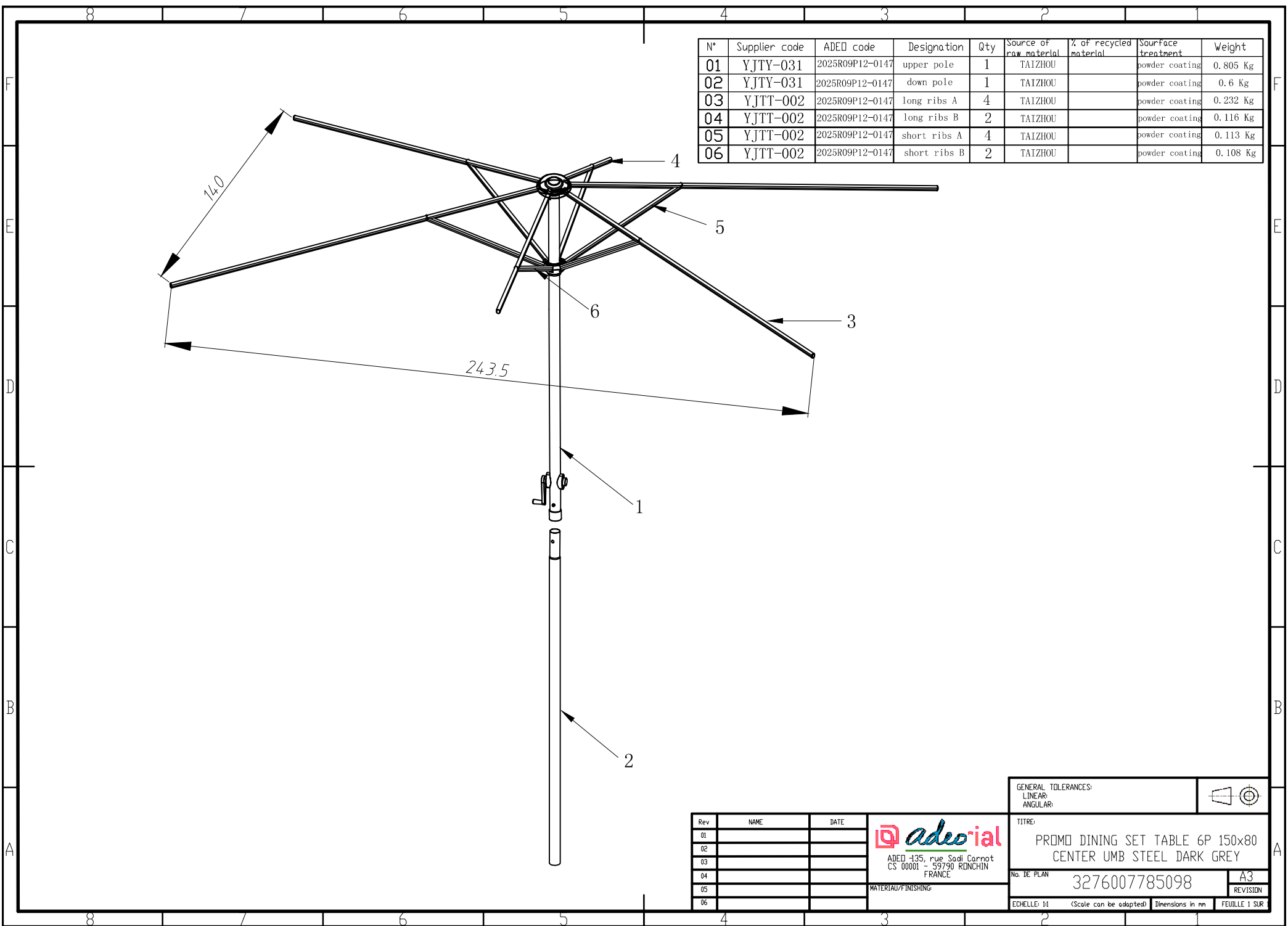

N°	Supplier code	ADED code	Designation	Qty	Source of raw material	% of recycled material	Surface treatment	Weight
01	YJTY-031	2025R09P12-0147	upper pole	1	TAIZHOU		powder coating	0.805 Kg
02	YJTY-031	2025R09P12-0147	down pole	1	TAIZHOU		powder coating	0.6 Kg
03	YJTT-002	2025R09P12-0147	long ribs A	4	TAIZHOU		powder coating	0.232 Kg
04	YJTT-002	2025R09P12-0147	long ribs B	2	TAIZHOU		powder coating	0.116 Kg
05	YJTT-002	2025R09P12-0147	short ribs A	4	TAIZHOU		powder coating	0.113 Kg
06	YJTT-002	2025R09P12-0147	short ribs B	2	TAIZHOU		powder coating	0.108 Kg

Rev	NAME	DATE
01		
02		
03		
04		
05		
06		

adeor|ial
 ADED 435, rue Sadi Carnot
 CS 00001 - 59790 RONCHIN
 FRANCE

MATERIAU/FINISHING:

GENERAL TOLERANCES:
 LINEAR:
 ANGULAR:



TITRE:
 PROMO DINING SET TABLE 6P 150x80
 CENTER UMB STEEL DARK GREY

No. DE PLAN: 3276007785098

A3

REVISION

ECHELLE: 1:1 (Scale can be adapted) Dimensions in mm FEUILLE 1 SUR