

no	rould ref	part designation	qty	raw material	spec	source of raw material	% of recycled material	surface treatment	part net weight
1	YLD-2300	Blach tube	1	Aluminum	500.20x1, 2x1,550	Ta1zhuo		Powder coating	0.04601114
2	YLD-2300	Roof rail tube	1	Aluminum	500.20x1, 2x1,785	Ta1zhuo		Powder coating	0.347807297
3	YLD-1523	Iron foot tube	4	Aluminum	50x28x1, 5x1,775	Ta1zhuo		Powder coating	1.31974621
4	YLD-1523	Short foot tube	2	Aluminum	50x28x1, 5x1,20	Ta1zhuo		Powder coating	0.131712048
5	YLD-499	Short seat frame tube	2	Aluminum	40x40x1, 2x1,770	Ta1zhuo		Powder coating	0.79341194
6	YLD-499	back horizontal tube	1	Aluminum	40x40x1, 2x1,005	Ta1zhuo		Powder coating	0.524879767
7	YLD-1956	Seat board	4	Aluminum	60x8x1,5315	Ta1zhuo		Powder coating	1.82772684
8	YLD-079X	Seat support tube	2	Aluminum	20x20x1, 2x1,80	Ta1zhuo		Powder coating	0.33093613
9	YLD-177A	Foot length support tube 1	1	Aluminum	30x25x2, 0x1,45	Ta1zhuo		Powder coating	0.35065476
10	YLD-177A	Foot short support tube 1	2	Aluminum	30x25x2, 0x1,95	Ta1zhuo		Powder coating	0.12670714
11	YLD-177A	Foot length support tube 2	1	Aluminum	30x25x2, 0x1,480	Ta1zhuo		Powder coating	0.81841072
12	YLD-177A	Foot short support tube 2	2	Aluminum	30x25x2, 0x1,05	Ta1zhuo		Powder coating	0.11430155
13	J01960	Anterior horizontal tube	1	Aluminum	40x40x1, 2x1,00	Ta1zhuo		Powder coating	1.15943987
14	YLD-511	Lining pipe1	2	Aluminum	28x20x1, 2x1,00	Ta1zhuo		Powder coating	0.55438844
15	YLD-511	Lining pipe2	4	Aluminum	28x20x1, 2x1,05	Ta1zhuo		Powder coating	0.11841976
16	YLD-511	Lining pipe3	2	Aluminum	28x20x1, 2x1,95	Ta1zhuo		Powder coating	0.053596024

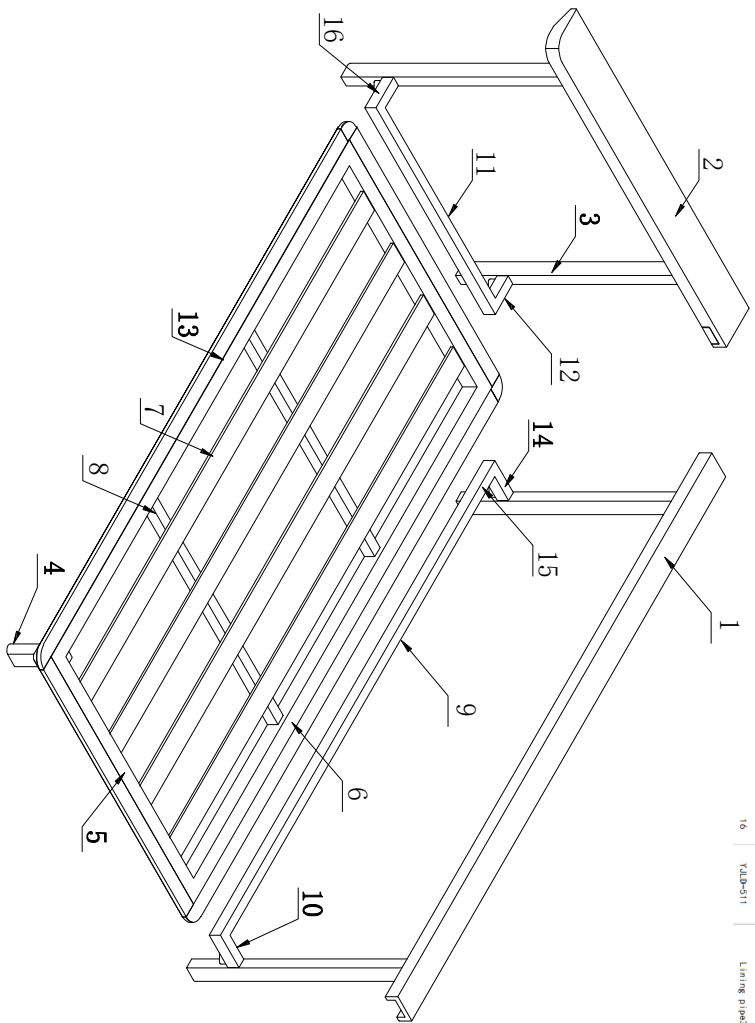

Rev	NAME	DATE
01		
02		
03		
04		
05		
06		

MATERIAL FINISHING

ADEO-135, rue Sadi Carnot
CS 00007 - 59780 RONCHIN
FRANCE

GENERAL TOLERANCES: $\pm 0.1mm$ W $\pm 1.0mm$ H $\pm 1.0mm$
LINEAR: $\pm 0.5mm$
ANGULAR:



TITRE:

No. DE PLAN: 3276007784954

REVISION: A3

ECHELLE: 1:1 (Scale can be adapted)

Dimensions in mm

FEUILLE 1 SUR 1