

FACADE COUL.140CM SHIVA ALU
FACADE COUL.160CM SHIVA ALU

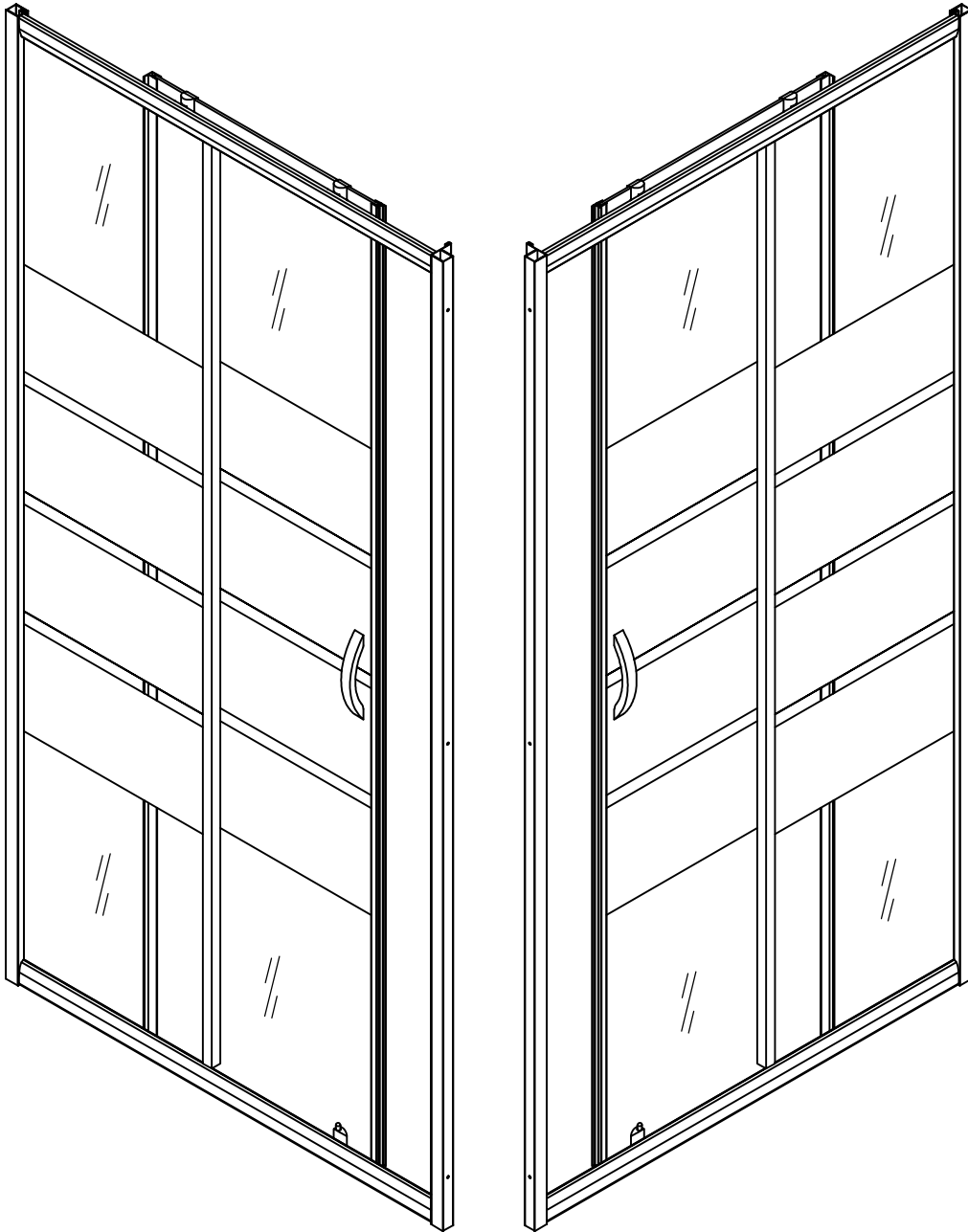

(1385--1415)X1900MM
(1585--1615)X1900MM

A LIRE IMPERATIVEMENT AVANT INSTALLATION

- Avant de commencer l'assemblage, déballer toutes les pièces et contrôler leur état.
- Les parties en verre sont en verre trempé. Sous l'effet d'un choc, elles peuvent exploser en une multitude de très petits morceaux. Ces éléments nécessitent une **manipulation délicate**. Vous pouvez les protéger en les posant sur des couvertures ou des morceaux de moquette.
- Pour plus de facilité et de rapidité lors du montage nous vous conseillons d'**être à 2 personnes**.

NETTOYER ET ENTRETENIR SA FACADE

- Nettoyage régulier : utiliser un chiffon doux avec un détergent au pH neutre. En cas de difficulté à enlever la saleté, utiliser du vinaigre blanc d'alcool dilué avec de l'eau puis rincer à l'eau claire.
- Nettoyage du tartre : utiliser un chiffon doux et du jus de citron et/ou du vinaigre blanc d'alcool chaud puis rincer à l'eau claire.
- **Ne jamais utiliser** de nettoyeur contenant des grains de polissage, d'acétone, de chlore, d'ammoniaque (javel) ou tout autre nettoyeur agressif à base d'acide.

CONDITIONS DE GARANTIE

- Nos produits sont **garantis 2 ans, pièces uniquement, hors casse. Ne prend pas en compte la main d'oeuvre**. La garantie s'exerce au domicile du revendeur, coût de transport et de démontage à la charge du client.
- **Non application de la garantie** : montage incorrect, défaut d'entretien, calcaire, accident ou choc, utilisation de produits abrasifs ou corrosifs, modification du revêtement de surface d'origine.
- Conserver la notice ainsi qu'un document officiel d'achat (facture, ticket de caisse) pour toute réclamation ou demande de pièces détachées.

TAMPON DU NUMERO DE SERIE:

XIS



VERPLICHT TE LEZEN VOOR INSTALLATIE

- Voor aanvang van montage alle onderdelen uitpakken en de controleren.
- Trek de beschermfolie geleidelijk van de opvangbak (douchebak) (en van de afdekkap indien aanwezig)
- Voor eenvoudige en snelle montage raden we u aan **met 2 personen te werken**.

SCHOONMAAK EN ONDERHOUD VAN DE CABINE

- Regelmatig onderhoud: gebruik een zachte doek met een pH-neutraal schoonmaakmiddel. Bij moeilijk verwijderbaar vuil, gebruik inmaakazijn op basis van alcohol verdund met water en daarna afspoelen met water.
- Verwijderen van aanslag: gebruik een zachte zoek met warme citroensap en/of inmaakazijn op basis van alcohol en daarna afspoelen water.
- **Nooit** een schoonmaakmiddel **gebruiken** dat polijstkorrels, aceton, chloor, ammoniak (bleekmiddel) bevat, of een ander agressief schoonmaakmiddel op basis van zuren.

GARANTIEVOORWAARDEN

- Onze producten hebben **een garantie van 2 jaars, alleen op onderdelen, met uitzondering van breken. Exclusief arbeidsloon**. De garantie wordt uitgeoefend op lokatie van de dealer, kosten van transport en demontage zijn voor de klant.
- **Niet van toepassing op de garantie**: incorrecte montage, gebrek aan onderhoud, kalkaanslag, ongeval of schok, gebruik van schuurmiddelen of bijtende middelen, aanpassing van de originele coating.
- Bewaar de gebruiksaanwijzing en een officiële aankoopdocument (factuur, kassabon) voor alle claims of aanvraag van losse onderdelen.

STEMPEL VAN HET SERIENUMMER:



IMPORTANTE: LEER ANTES DE INSTALAR

- Antes de empezar a montar, sacar todas las piezas y verificarlas.
- Las piezas de vidrio son de vidrio templado. En caso de choque, explotan en miles de trocitos. Estos elementos necesitan una manipulación delicada. Se pueden proteger poniéndolas sobre manteles o trozos de moqueta.
- Para que el montaje sea más fácil, se aconseja que trabajen en él 2 personas.

LIMPIEZA DE LA MAMPARA

- Limpiar con regularidad: usar un trapo suave con un detergente de PH neutro. En caso de dificultad para quitar lo sucio, usar vinagre blanco y aclararlo con agua.
- Limpiar el tártaro : usar un trapo suave con zumo de limón y/o vinagre blanco de alcohol caliente, aclarar con agua
- Nunca usar detergente con granos de pulimento, acetona, cloro o amoníaco.

CONDICIONES DE GARANTÍA

- La garantía es de 2 años, solo incluye las piezas defectuosas, dejando a parte las roturas. No incluye la mano de obra. La garantía se aplica al domicilio del vendedor, coste de transporte, montaje y desmontaje a cargo del cliente.
- No se aplicará la garantía en caso de : Montaje incorrecto, Cal, accidente o choque, uso de productos abrasivos o corrosivos, Modificación del revestimiento original.
- Conservar las instrucciones de montaje y su prueba de compra (factura o ticket) para su reclamación o para pedir piezas destacadas

SELLO DEL NUMERO DE LA SERIE:

XIS



IMPORTANTE: LEIA ANTES DE INSTALAR

- Antes de iniciar a instalação, remova todas as peças e verificar.
- As peças de vidro são de vidro temperado. Em caso de colisão, explodir em milhares de pedaços. Estes elementos requerem um tratamento delicado. Pode ser protegido por colocar em panos ou peças de tapete.
- É aconselhável 2 pessoas para uma montagem mais fácil e rápida.

LIMPAR O TELA

- Limpeza regular: utilizar uma esponja suave com um detergente com pH neutro (produto de limpeza doméstico multiuso, detergente). Caso seja difícil remover a sujeira, utilizar vinagre branco de álcool diluído em água e enxaguar com água limpa.
- Limpeza do calcário: utilizar um pano suave, suco de limão e/ou vinagre branco de álcool quente e enxaguar com água limpa.
- Nunca utilizar produto de limpeza que contenha grãos de polimento, acetona, cloro, amoníaco (lixívia) ou qualquer outro produto agressivo à base de ácido.

CONDIÇÕES DE GARANTIA

- Nossos produtos têm uma garantia de 2 anos que cobre apenas peças que não se romperam. Não inclui mão de obra. A garantia se limita ao domicílio do revendedor, as despesas de transporte e desmontagem ficam a cargo do cliente.
- A garantia não se aplica a: montagem incorreta, produção de água quente não adaptada, falta de limpeza, calcário, acidente ou choque, utilização de produtos abrasivos ou corrosivos, alteração do revestimento de superfície original.
- Conservar as instruções e um documento oficial de compra (fatura, talão de caixa) para qualquer reclamação ou pedido de peças de reposição.

CARIMBO DO NÚMERO DE SÉRIE:



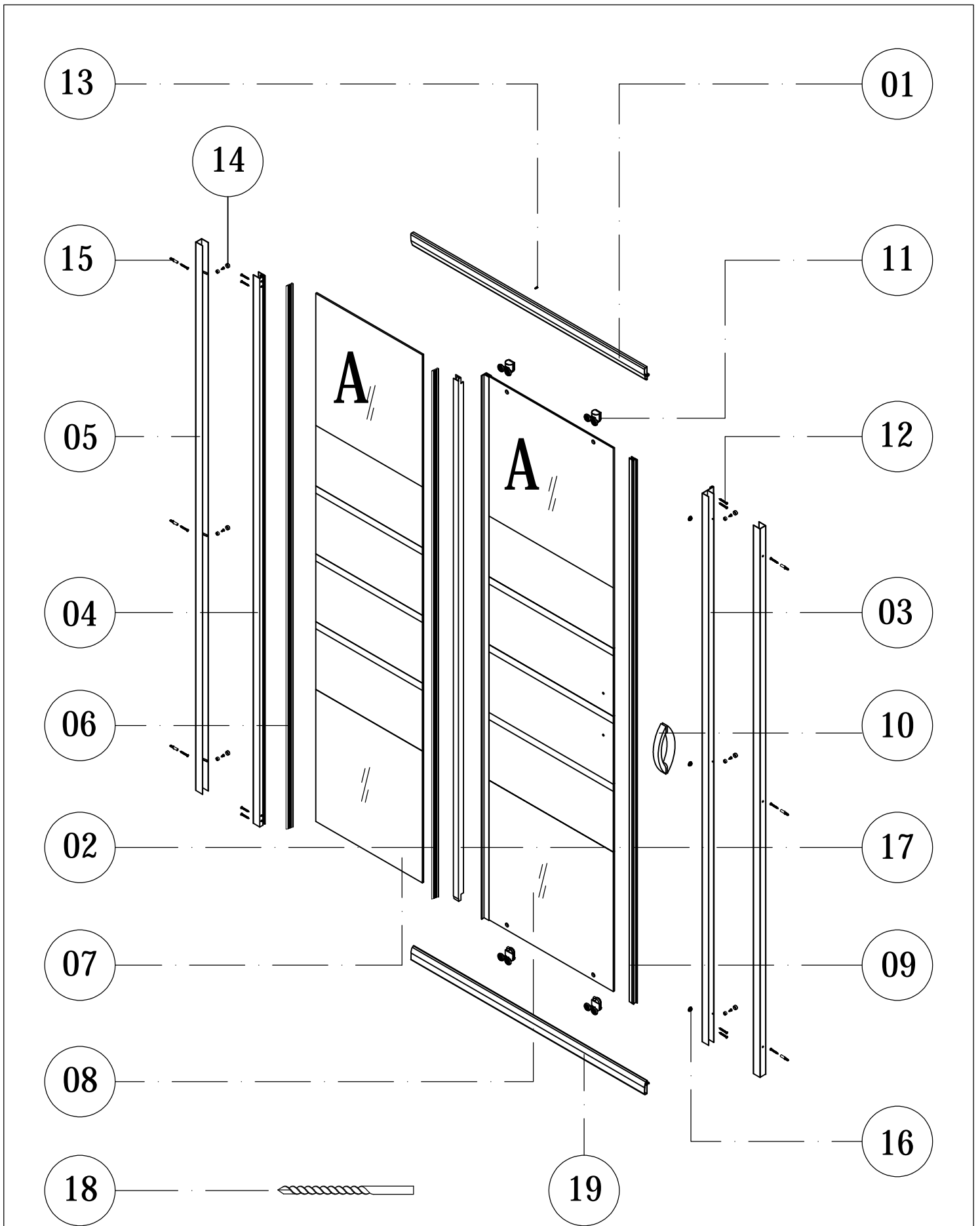

A = face anticalcaire / lado anticalcareo/ lado calcário / kalkaanslag kant

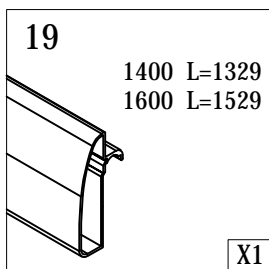
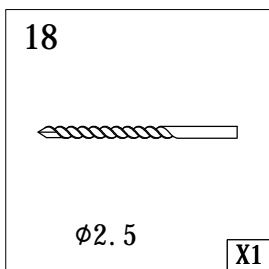
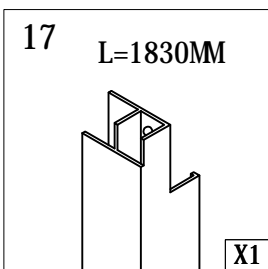
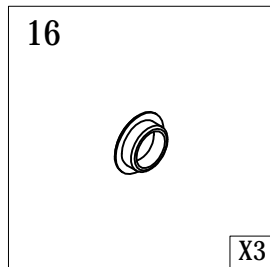
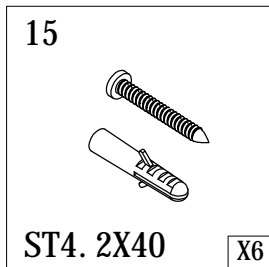
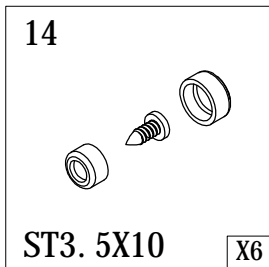
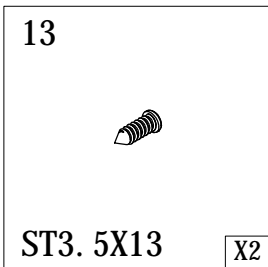
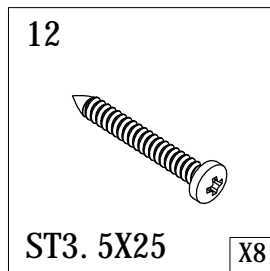
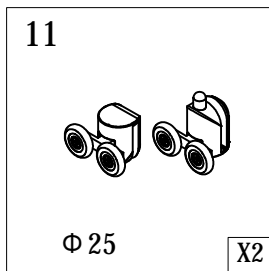
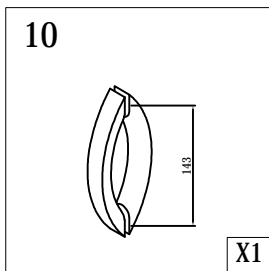
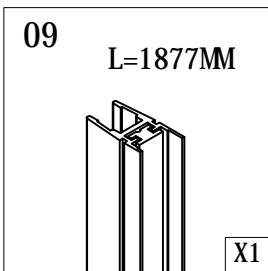
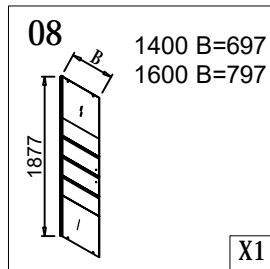
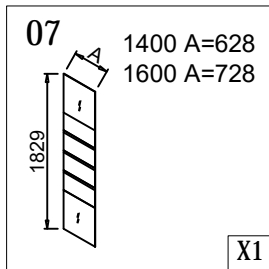
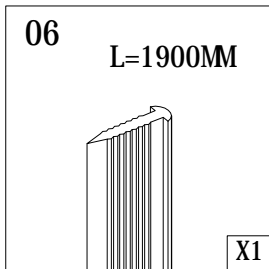
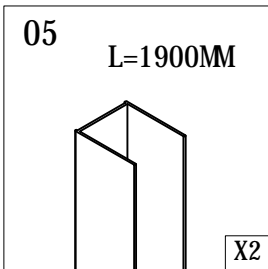
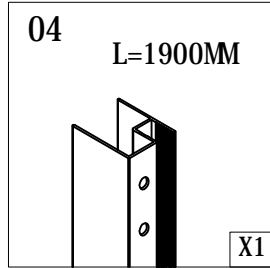
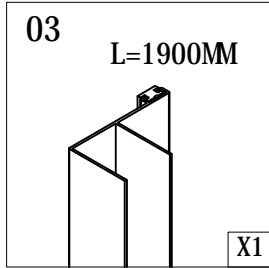
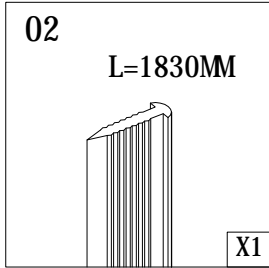
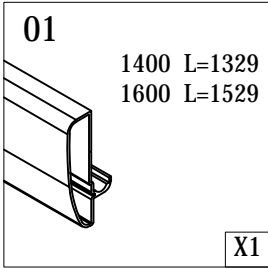
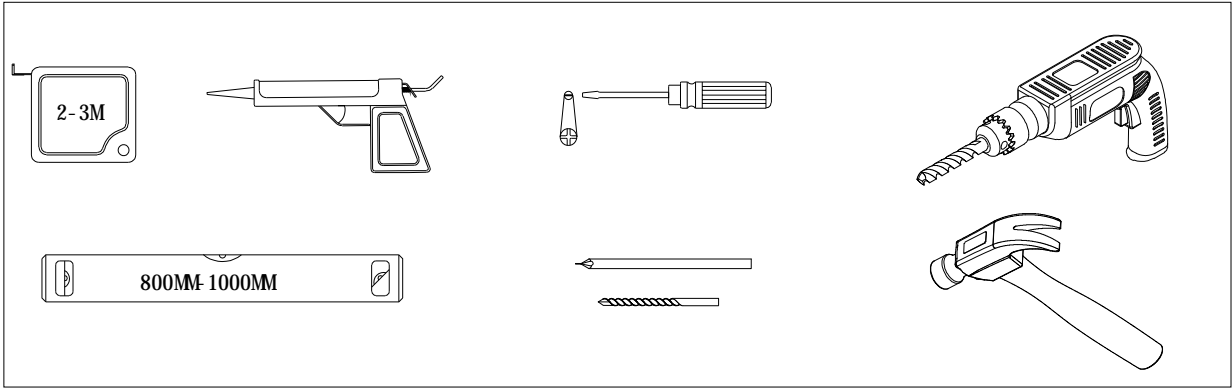

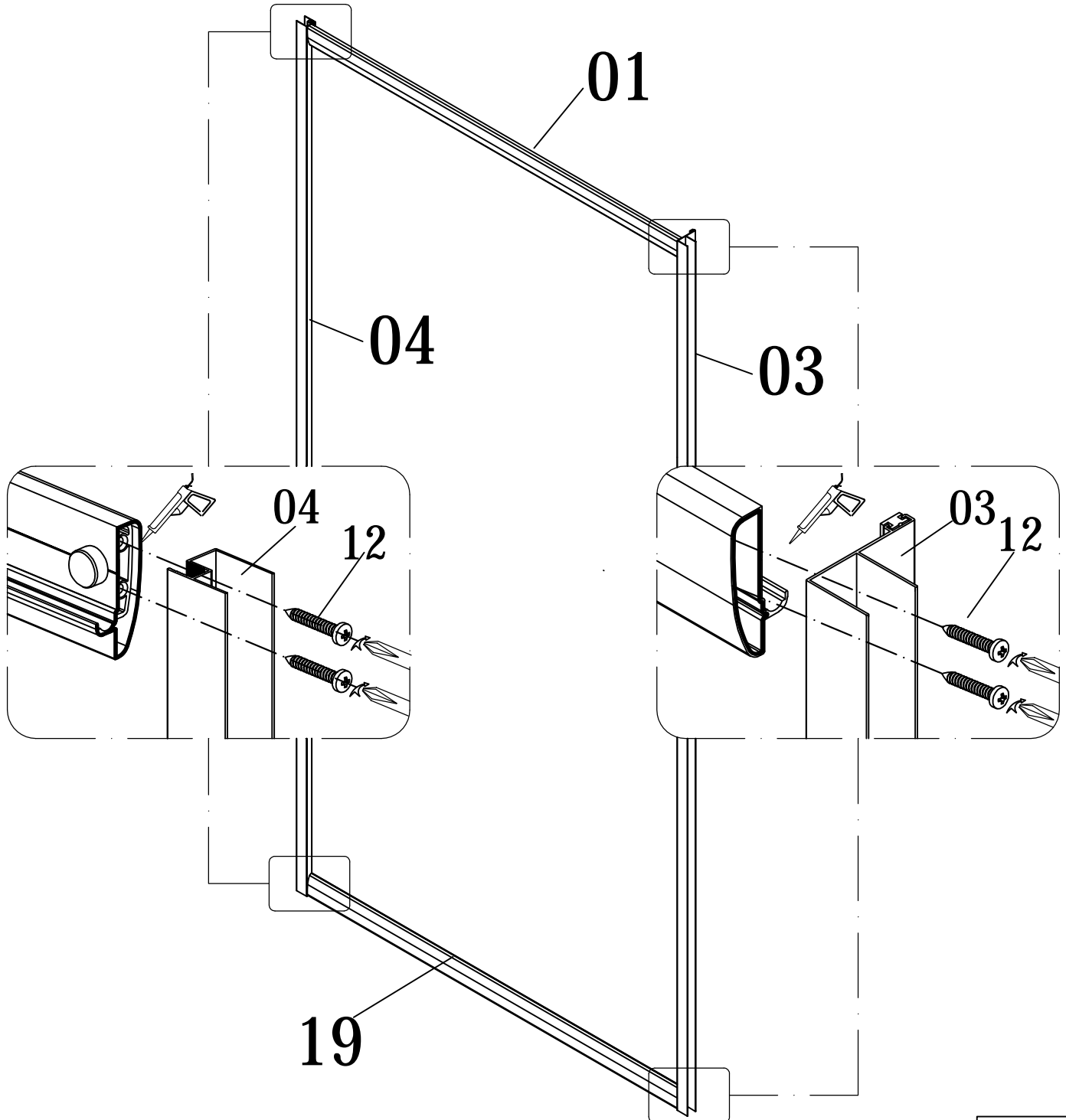
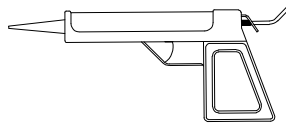
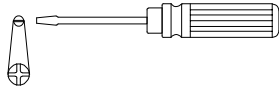
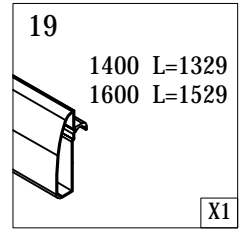
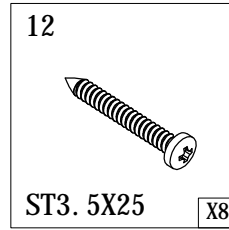
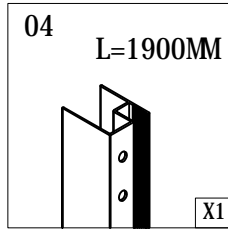
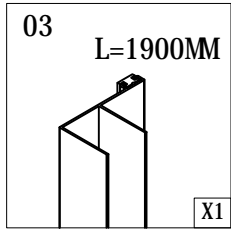
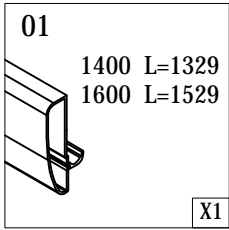

05

L=1900MM

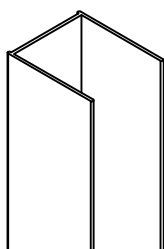

X2

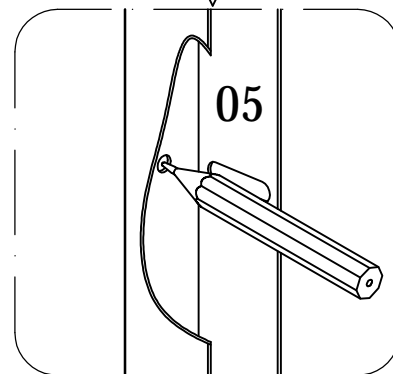
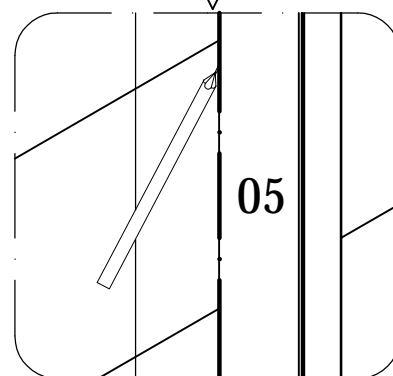
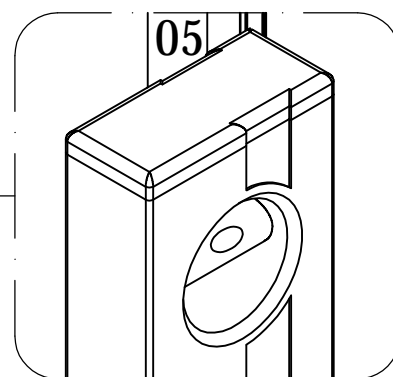
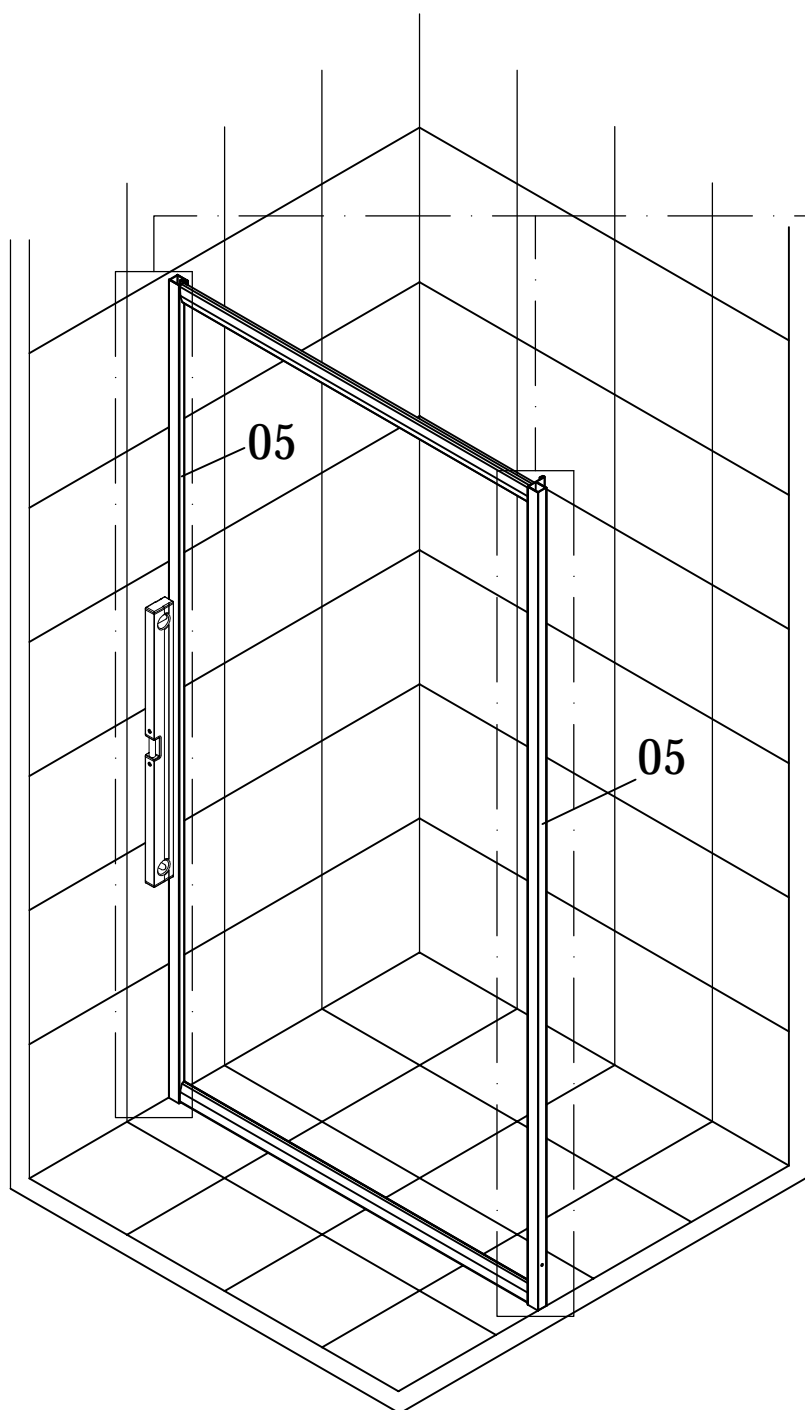
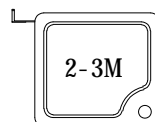
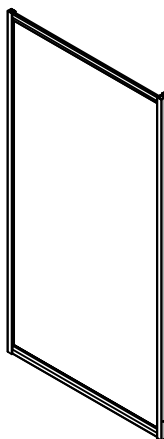

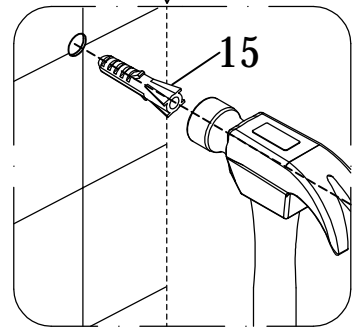
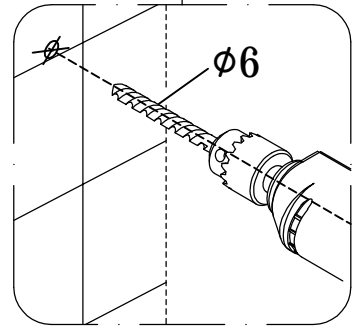
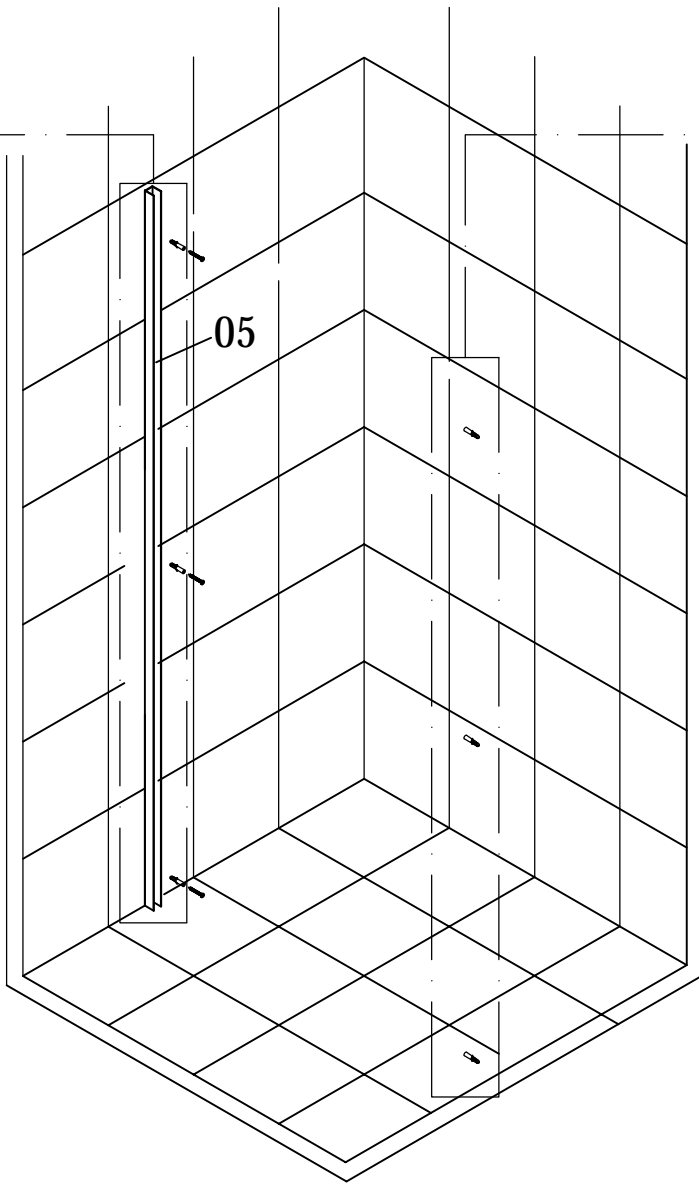
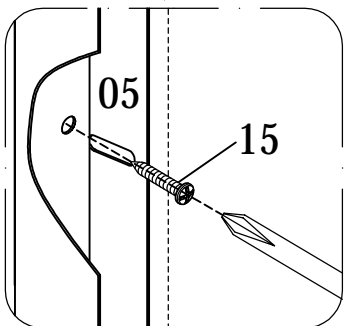
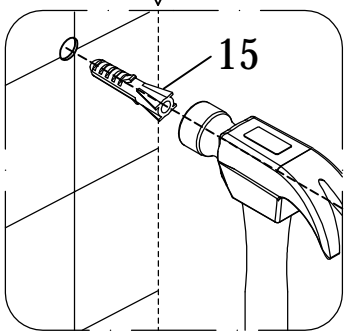
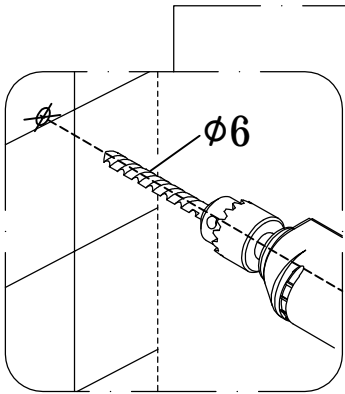
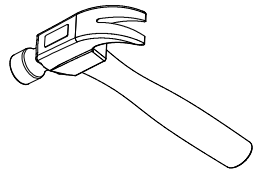
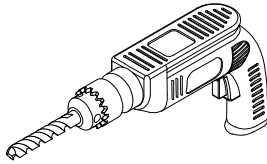
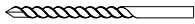
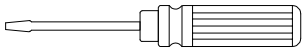
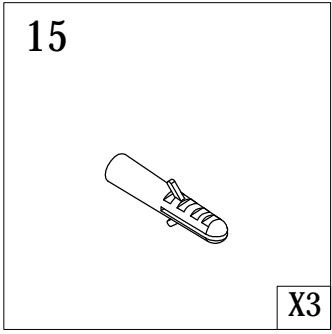
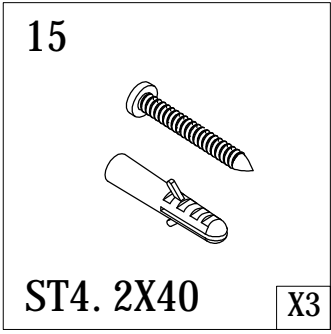
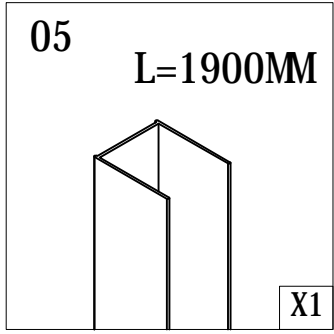

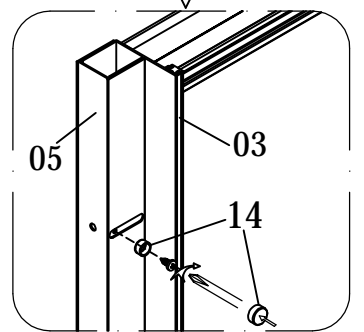
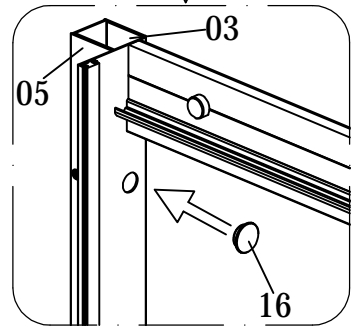
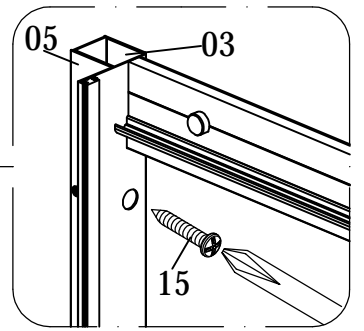
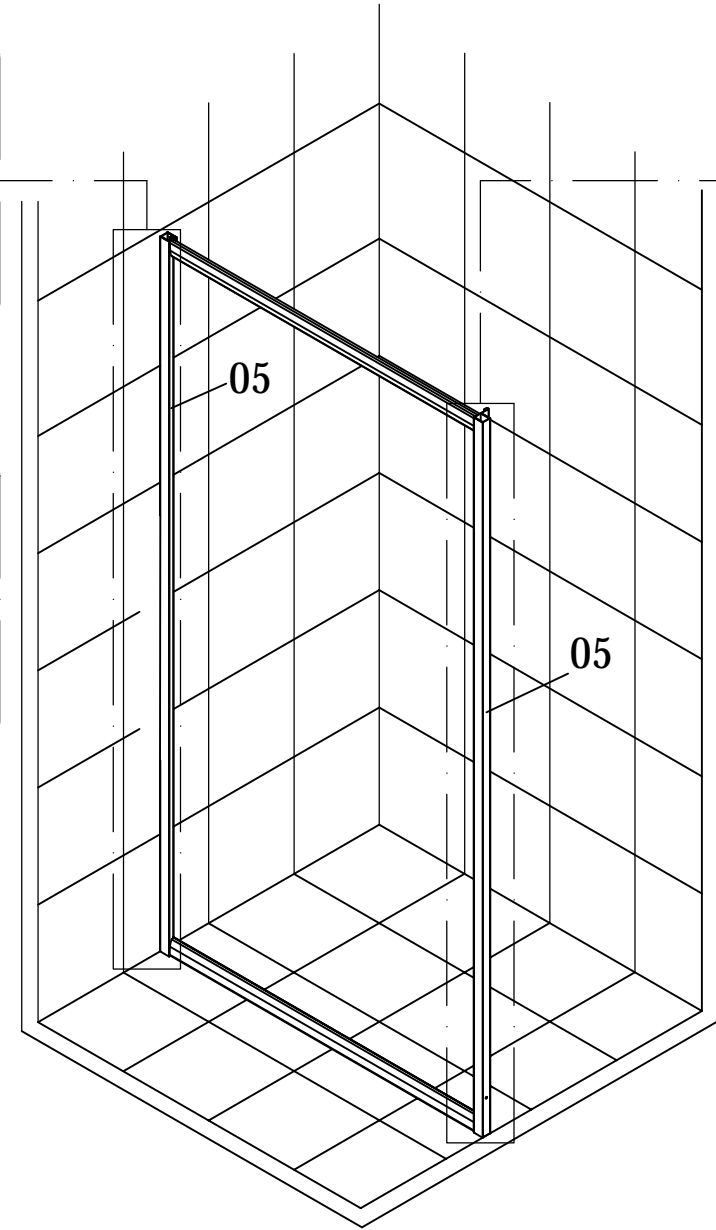
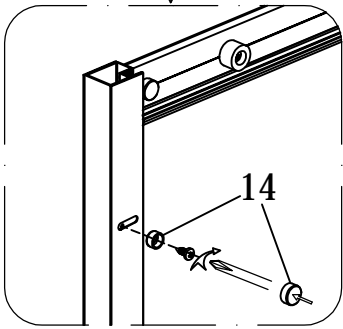
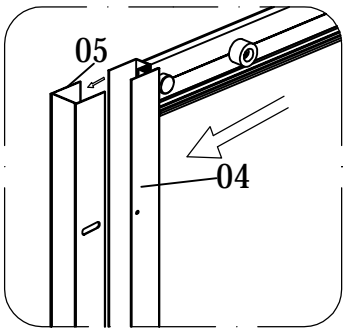
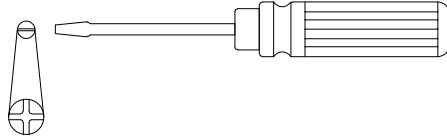
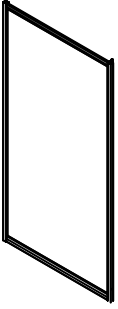
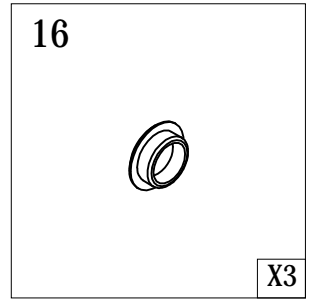
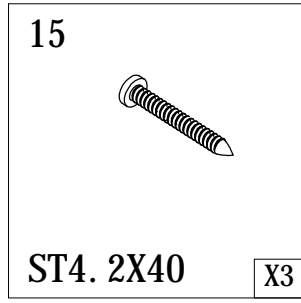
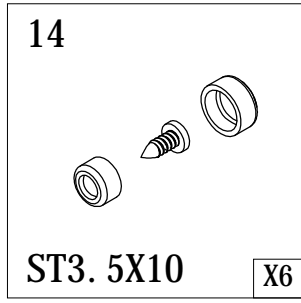
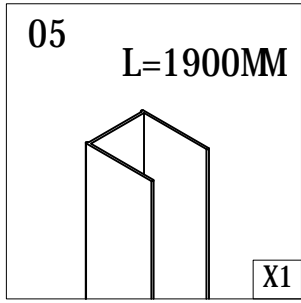

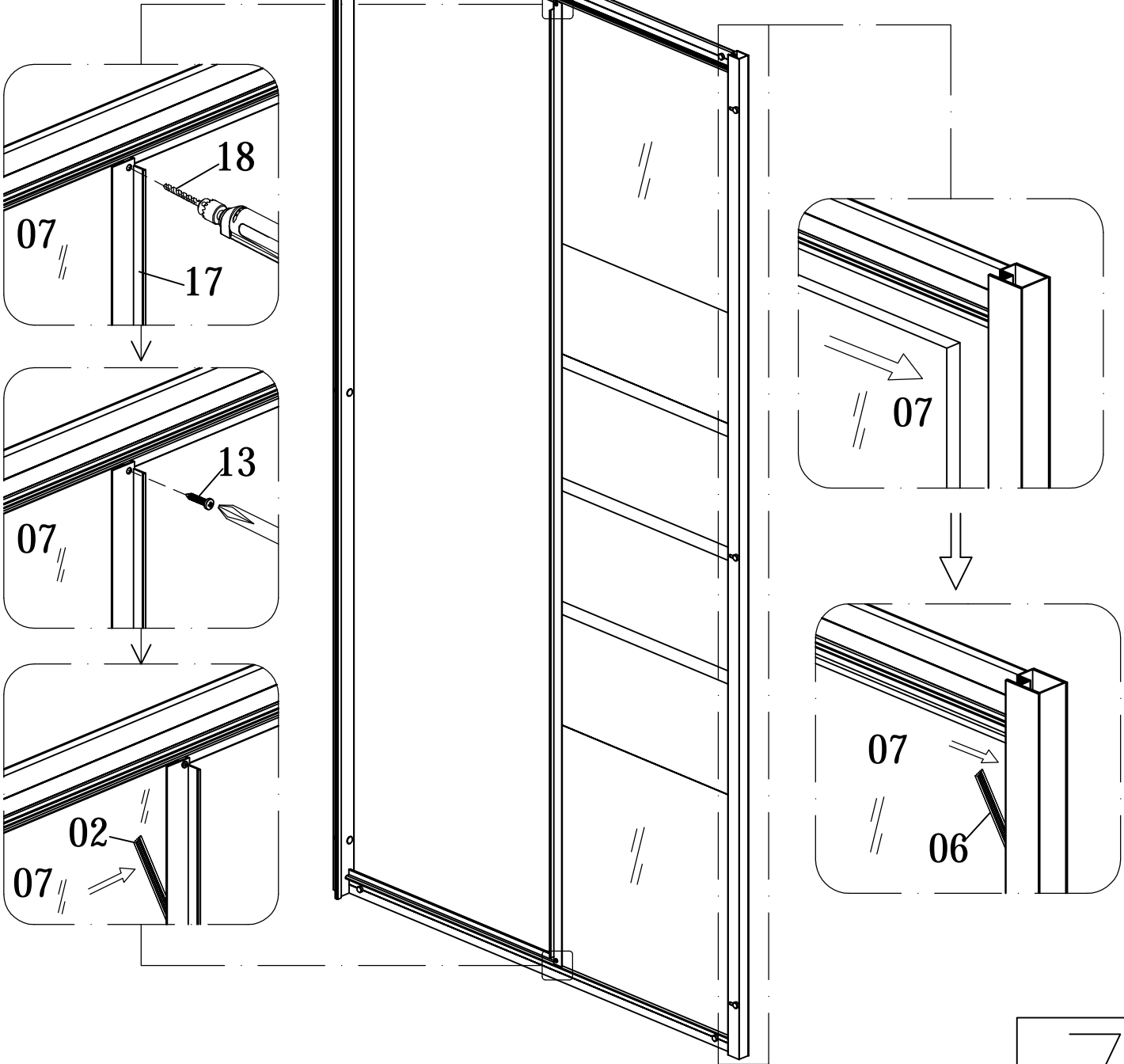
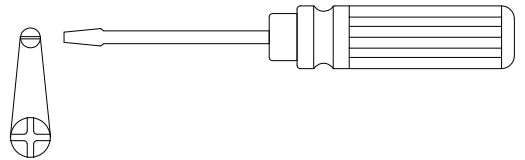
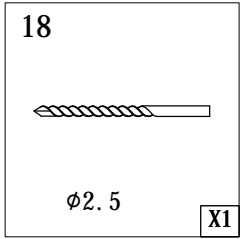
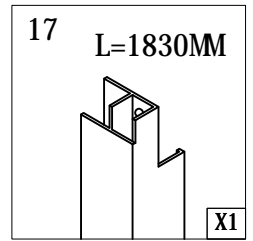
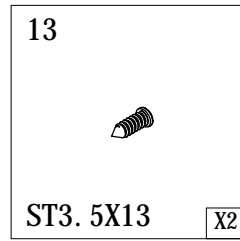
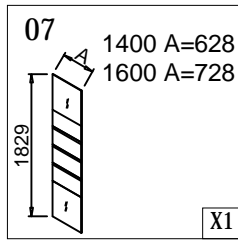
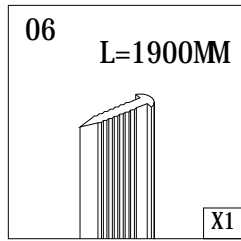
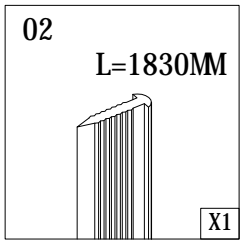

08
 1400 B=697
 1600 B=797

1877

B

X1

09
 L=1877MM

X1

10

143

X1

11

Φ 25

X2

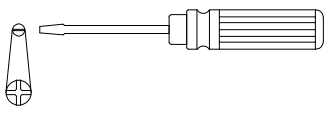

1400 B=697
 1600 B=797

09

08

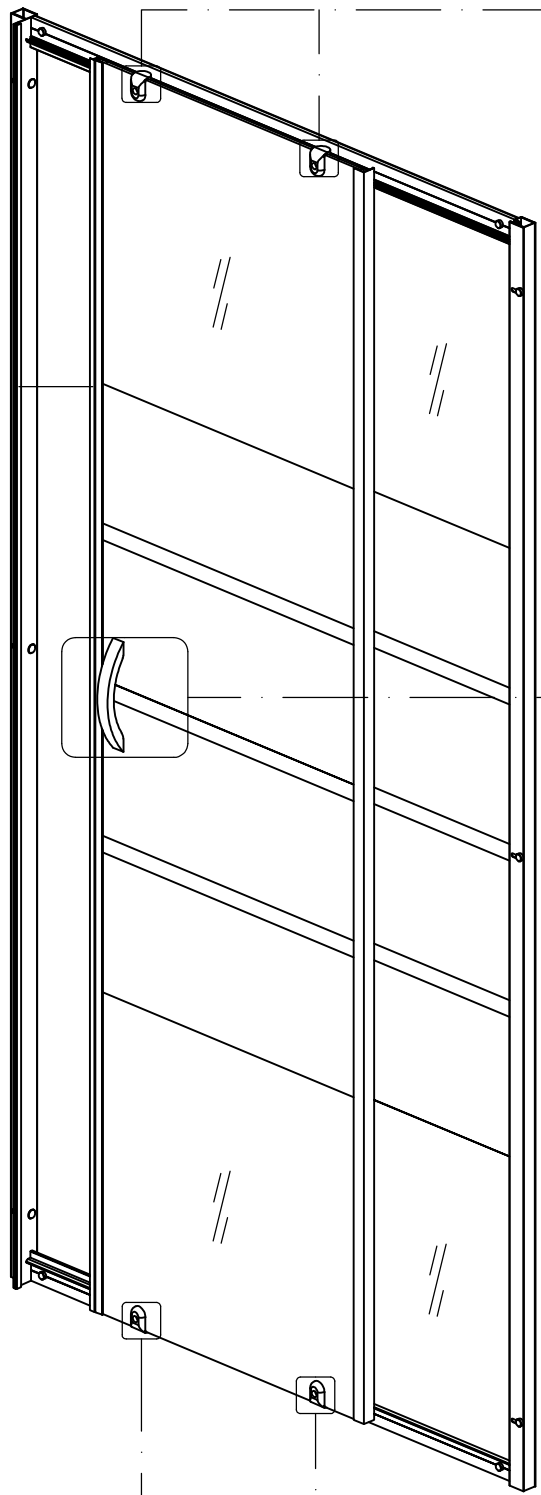

11

10

11

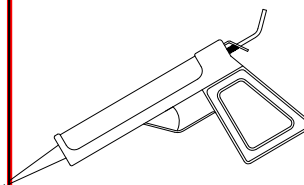
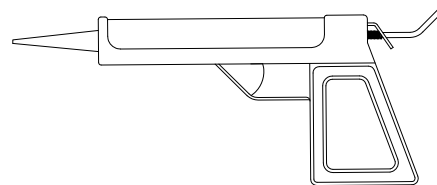
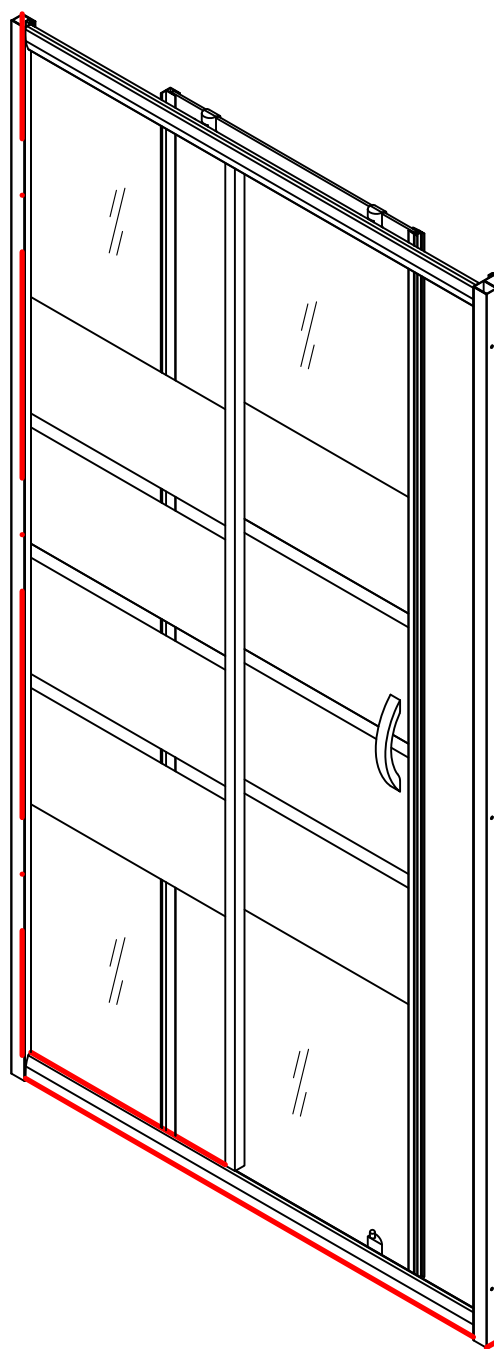

CE

LT AQUA +
2 Rue Gutenberg
16440 ROULLET - FRANCE
14

Déclaration de performances N° RPC-DoP-LT103
FACADE COUL.140CM SHIVA ALU
FACADE COUL.160CM SHIVA ALU
Code SACHQSHICFC14/SACHQSHICFC16

EN 14428: 2015+A1: 2018

Aptitude au nettoyage : Conforme
Résistance à l'impact : Conforme
Durabilité : Conforme