

MANUALE PER L'UTENTE

USER MANUAL | MODE D'EMPLOI | MANUAL DE USUARIO |
GEBRAUCHSANWEISUNG

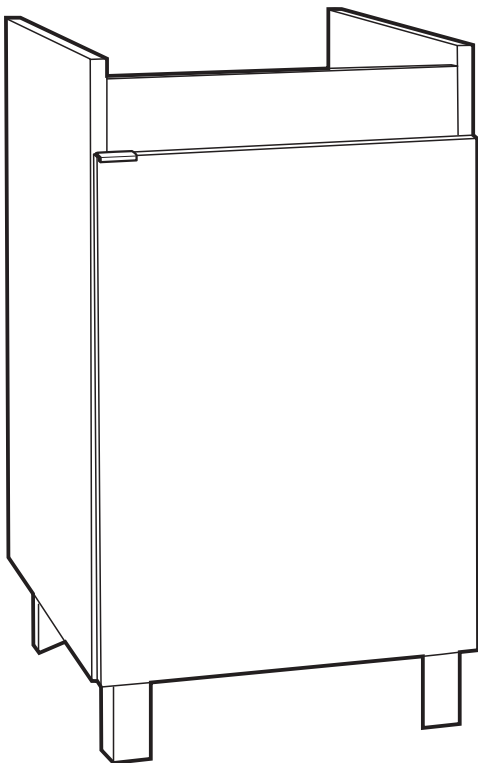

BASE MOBILE LAVATOIO 1 ANTA CON PIEDINI



MOBILE CON CATENA
per vasche bordo alto

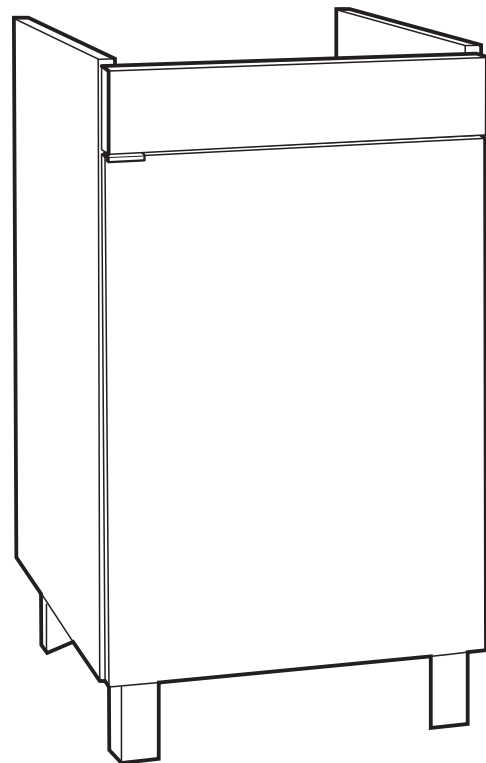

MOBILE CON FRONTALE
per vasche bordo basso

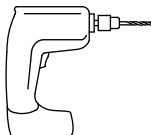
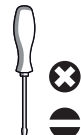

	<p>portata max 20 Kg uniformemente distribuiti. max 20 kg evenly distributed. max 20 kg bei gleichmäßig verteilt. max 20 kg uniformément répartie. max 20 kg distribuidos uniformemente carga máxima 20 kg uniformemente distribuida</p>		<p>montaggio in 60 min. assembly in 60 min. Montage in 60 min. assemblage en 60 min. montaje en 60 minutos de montagem em 60 minutos</p>
---	---	---	---

	<p>attrezzi da usare tools to use outils à utiliser Zu verwendendes Werkzeug Herramientas necesarias ferramentas a utilizar</p>				
---	--	---	---	---	---

PARTI DA MONTARE | ASSEMBLY PARTS | PIÈCES À ASSEMBLER | PIEZAS DE ENSAMBLE | MONTAGETEILE

MOBILE CON CATENA
per vasche bordo alto

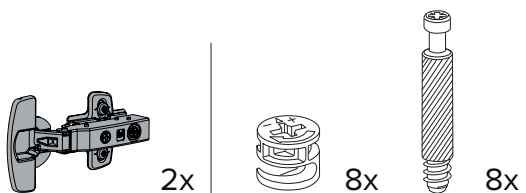
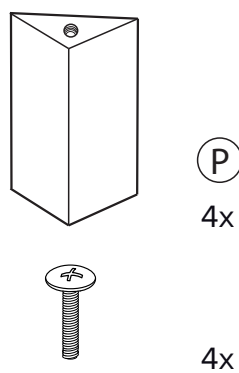
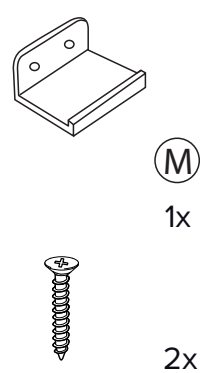
<p>KIT Viteria</p> 		
--	--	--

MOBILE CON FRONTALE
per vasche bordo basso

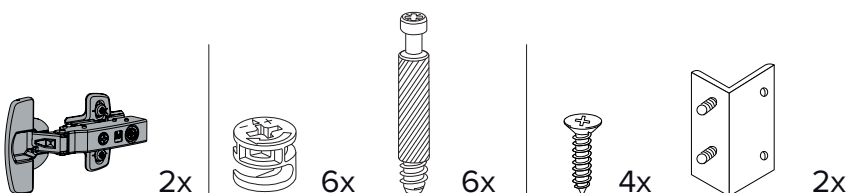
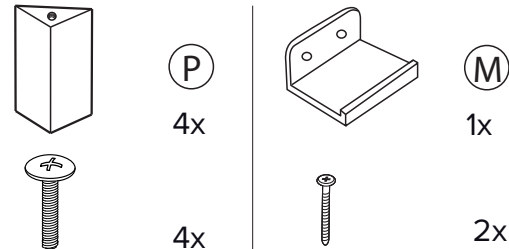
<p>KIT Viteria</p> 	
---	---

MOBILE CON CATENA per vasche bordo alto

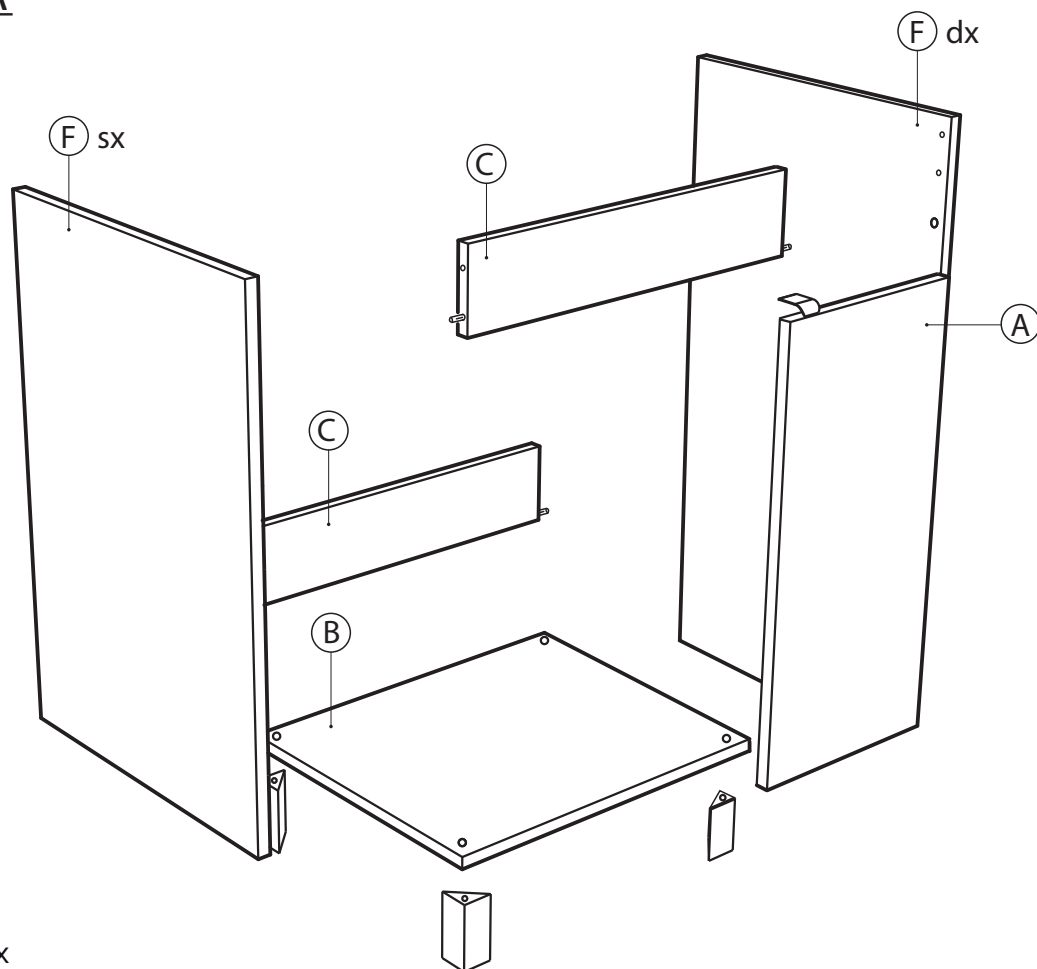

- (A) 1x Anta / Door
- (B) 1x Base / Base
- (C) 2x Catene / Front
- (F) 2x Fianchi / Side dx-sx

MOBILE CON FRONTALE per vasche bordo basso

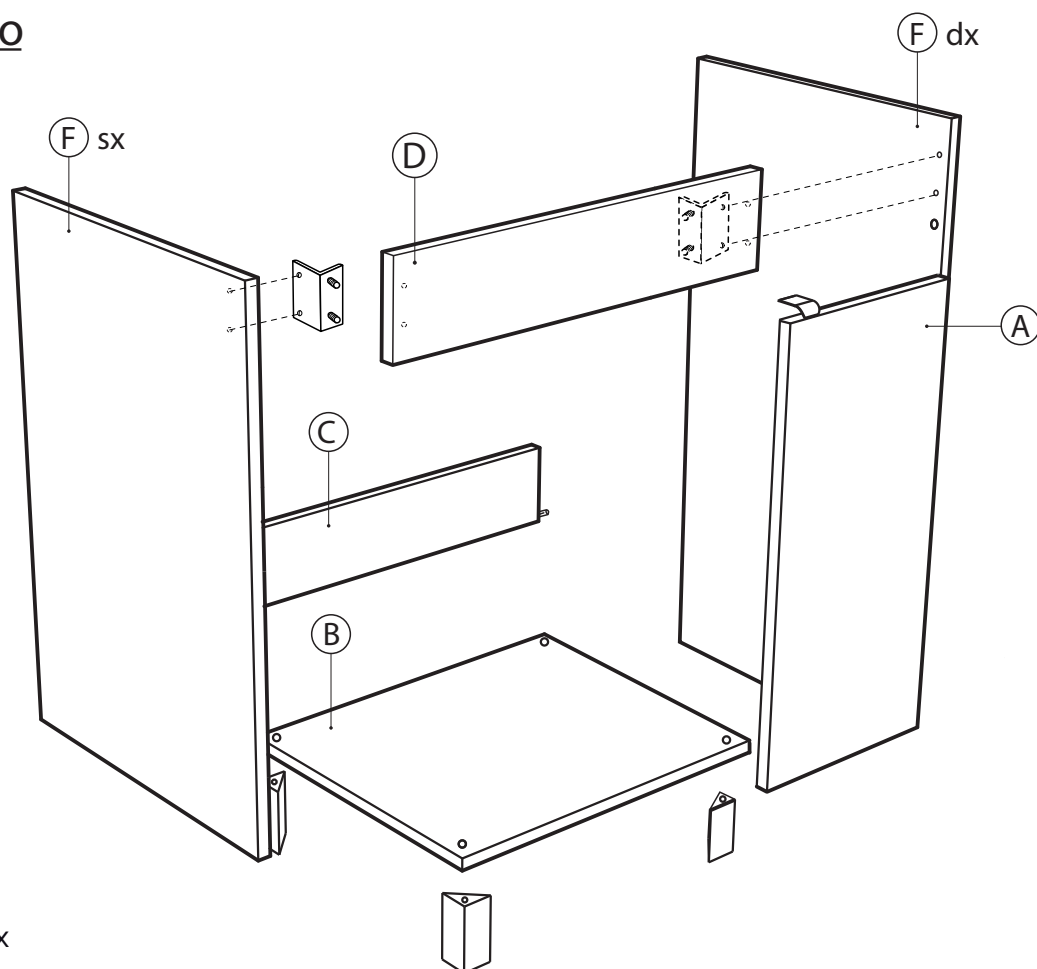

- (A) 1x Anta / Door
- (B) 1x Base / Base
- (C) 2x Catene / Front
- (D) 2x Frontale / Front
- (F) 2x Fianchi / Side dx-sx

1.

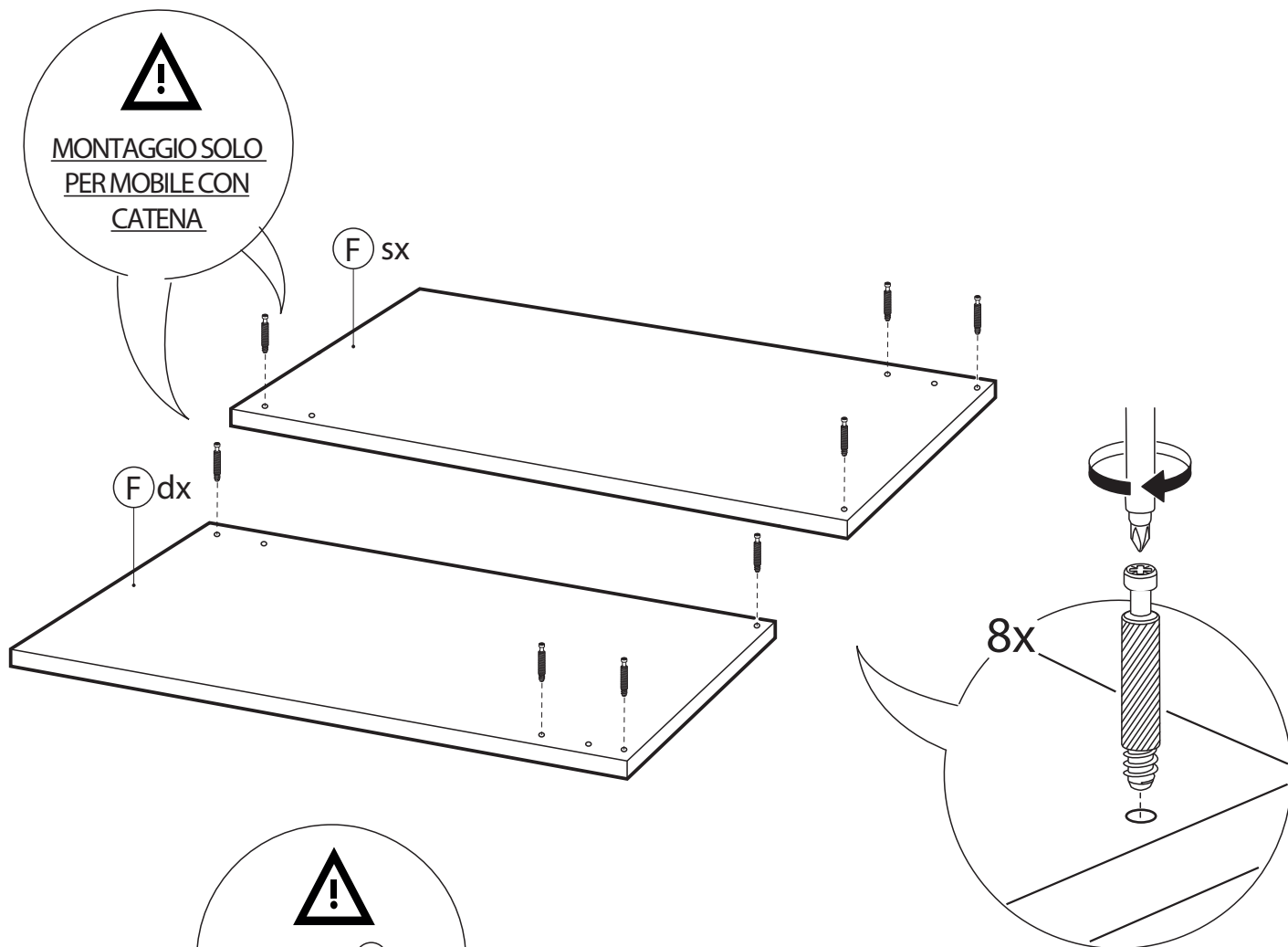

2.

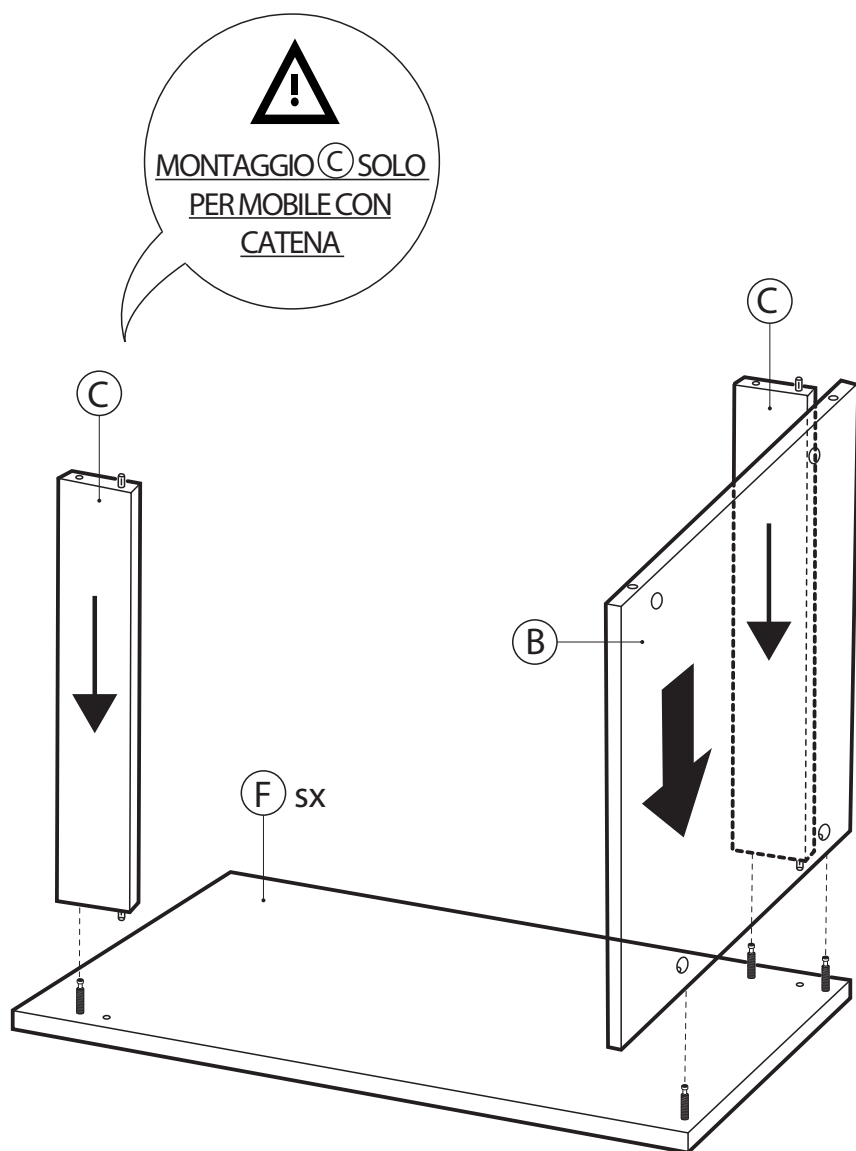

3.

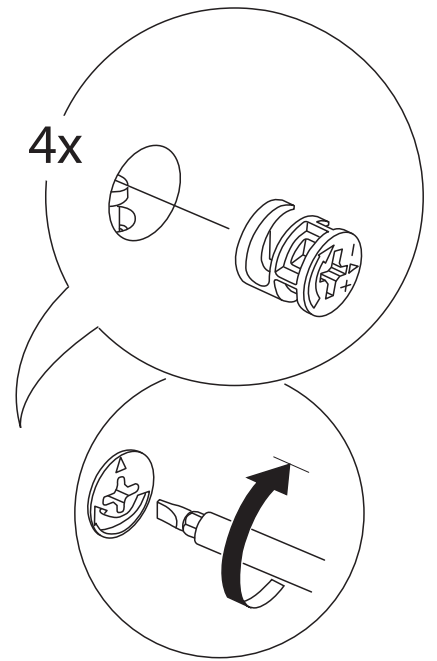
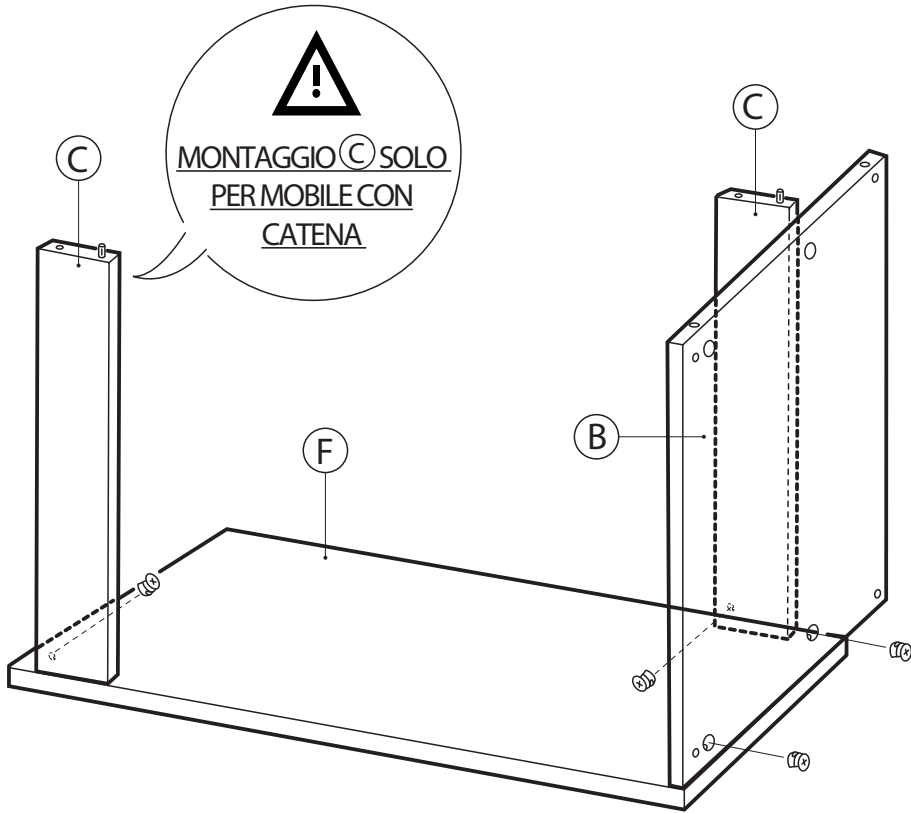

4.

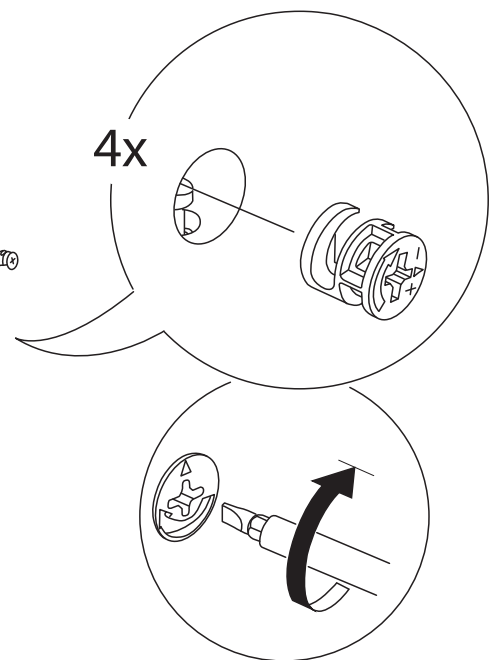
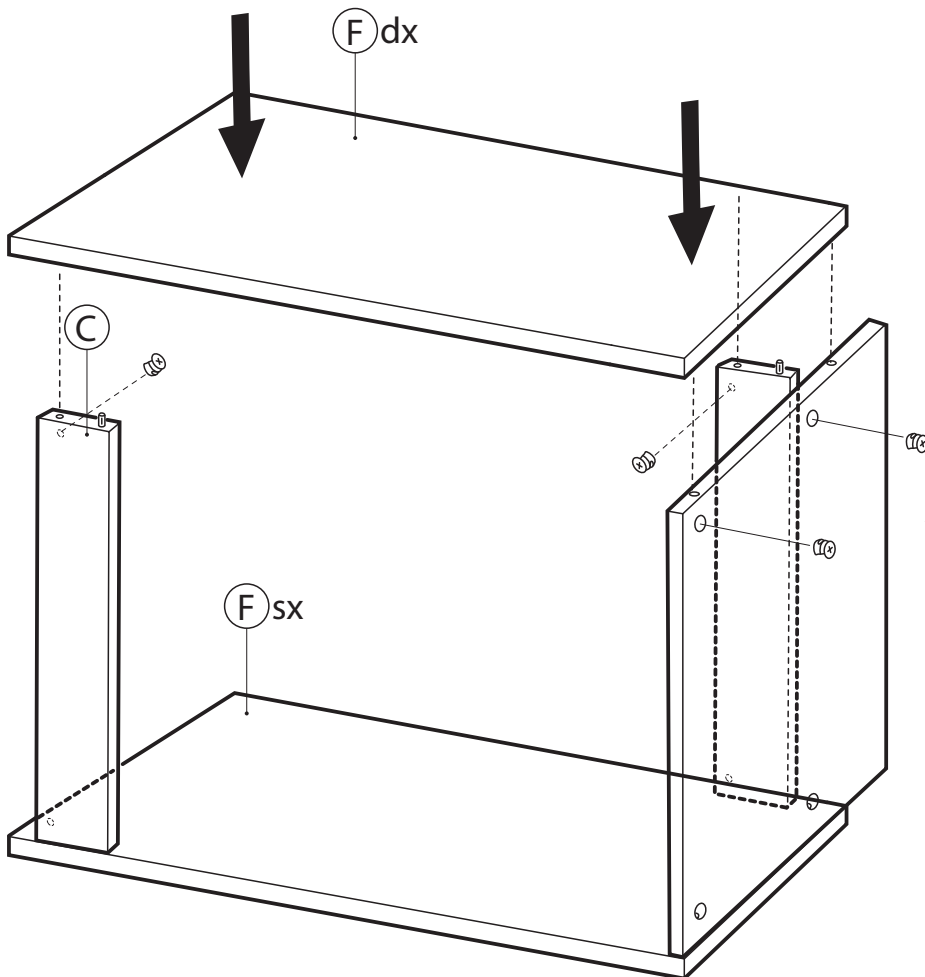

5.

MONTAGGIO  SOLO
PER MOBILE CON
CATENA

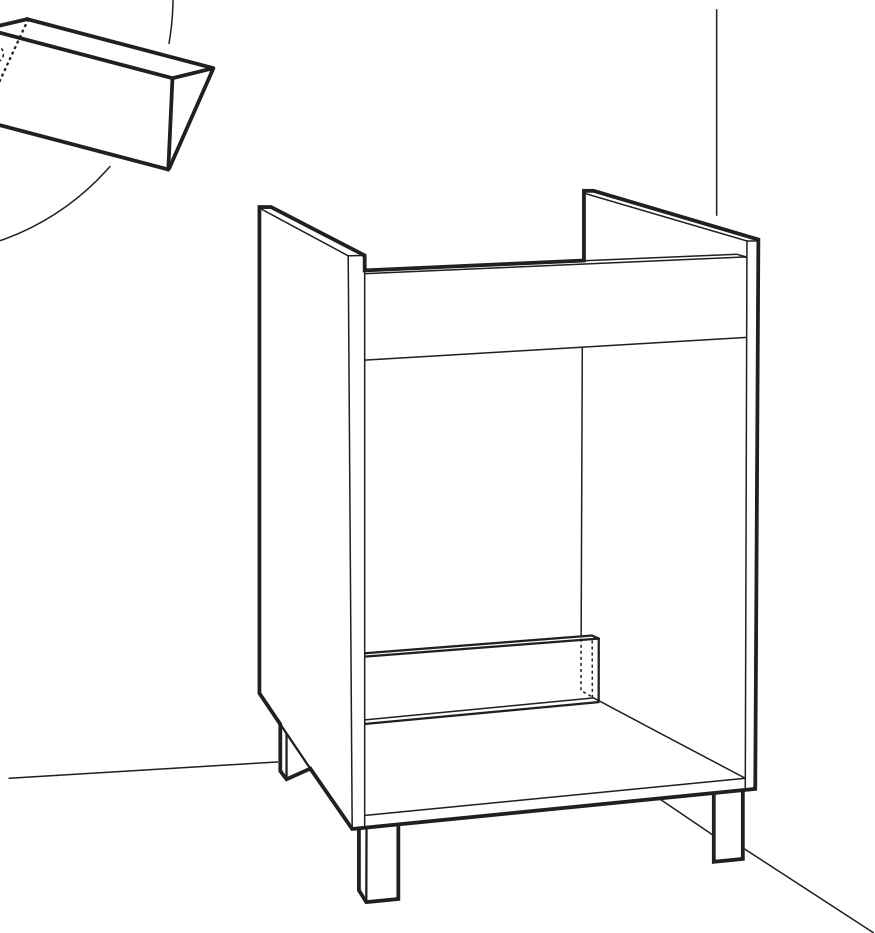
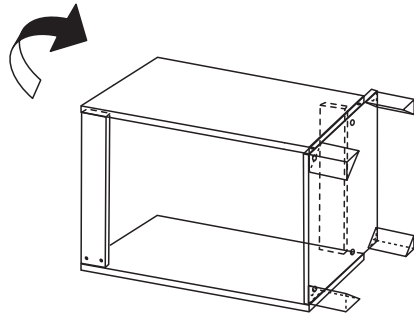
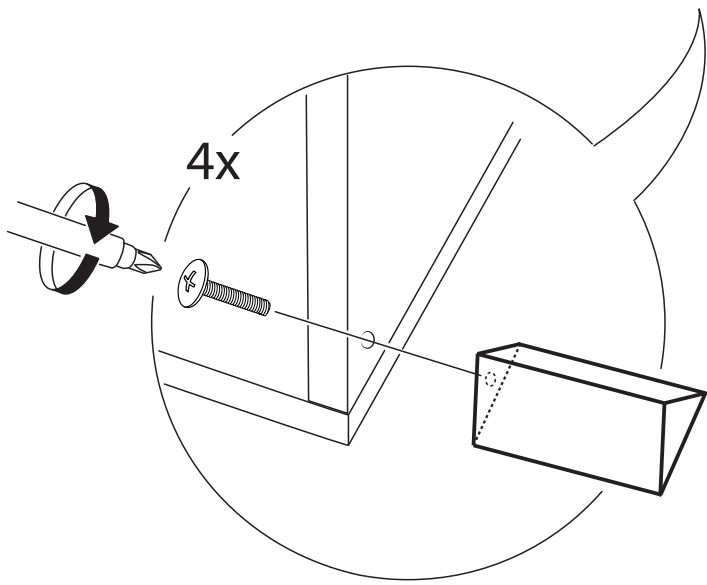
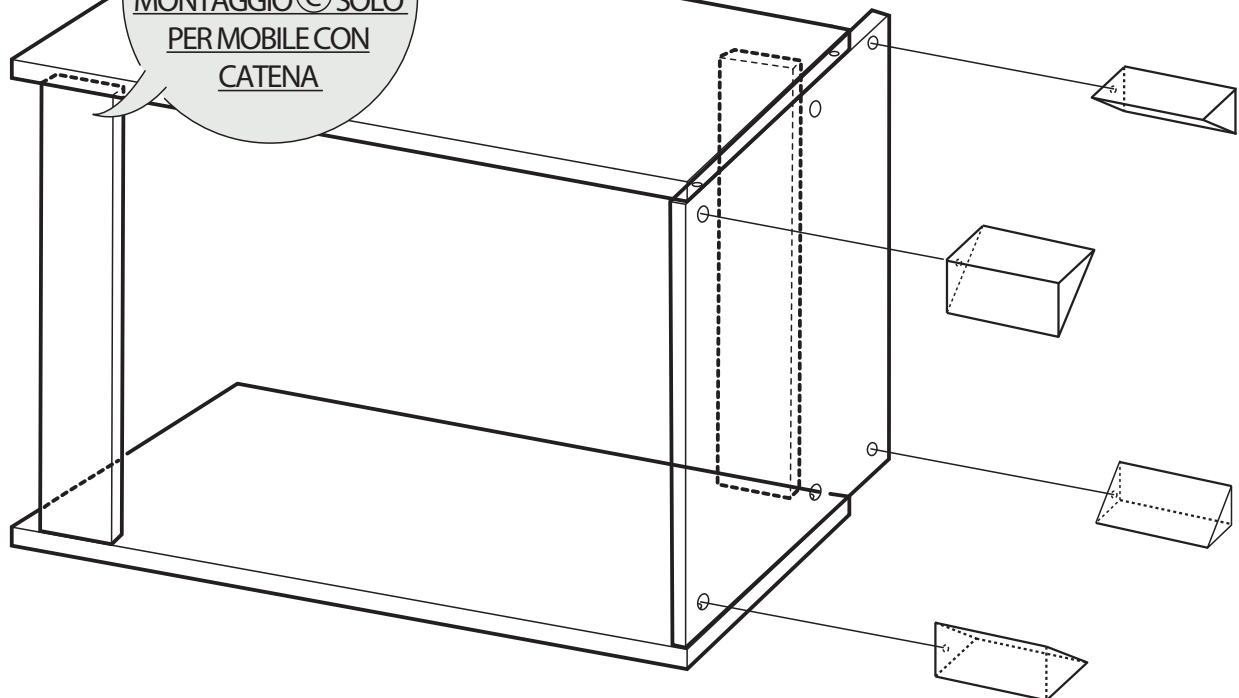

6.

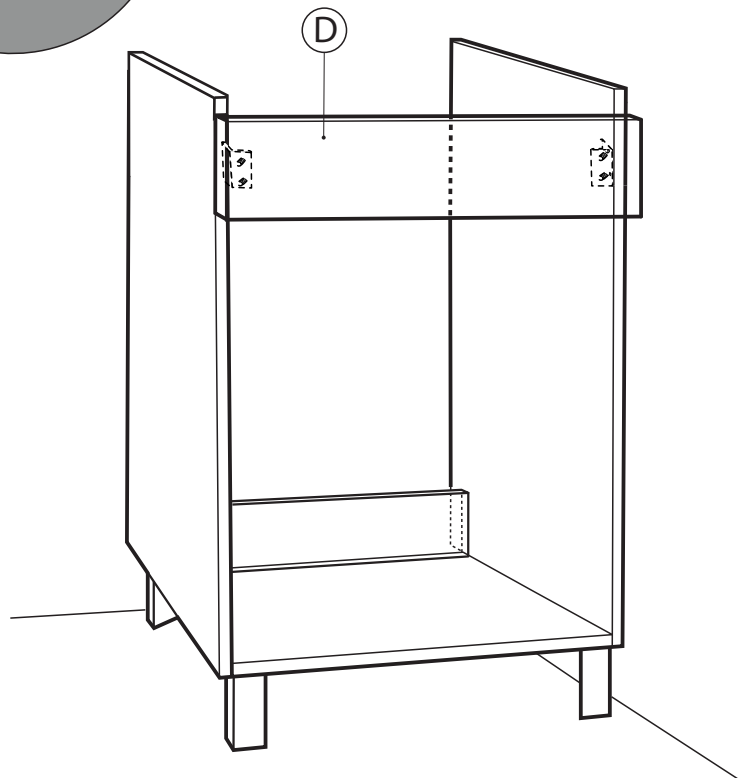
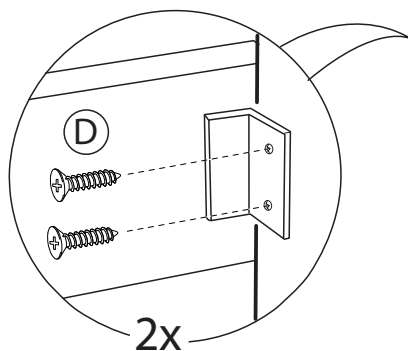
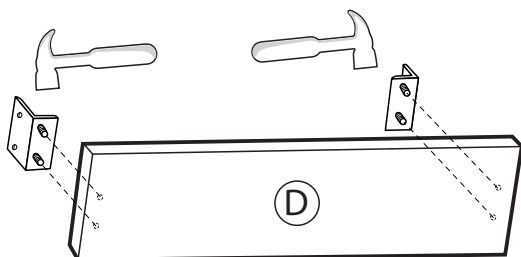

MONTAGGIO **D** SOLO
PER MOBILE CON
FRONTALE

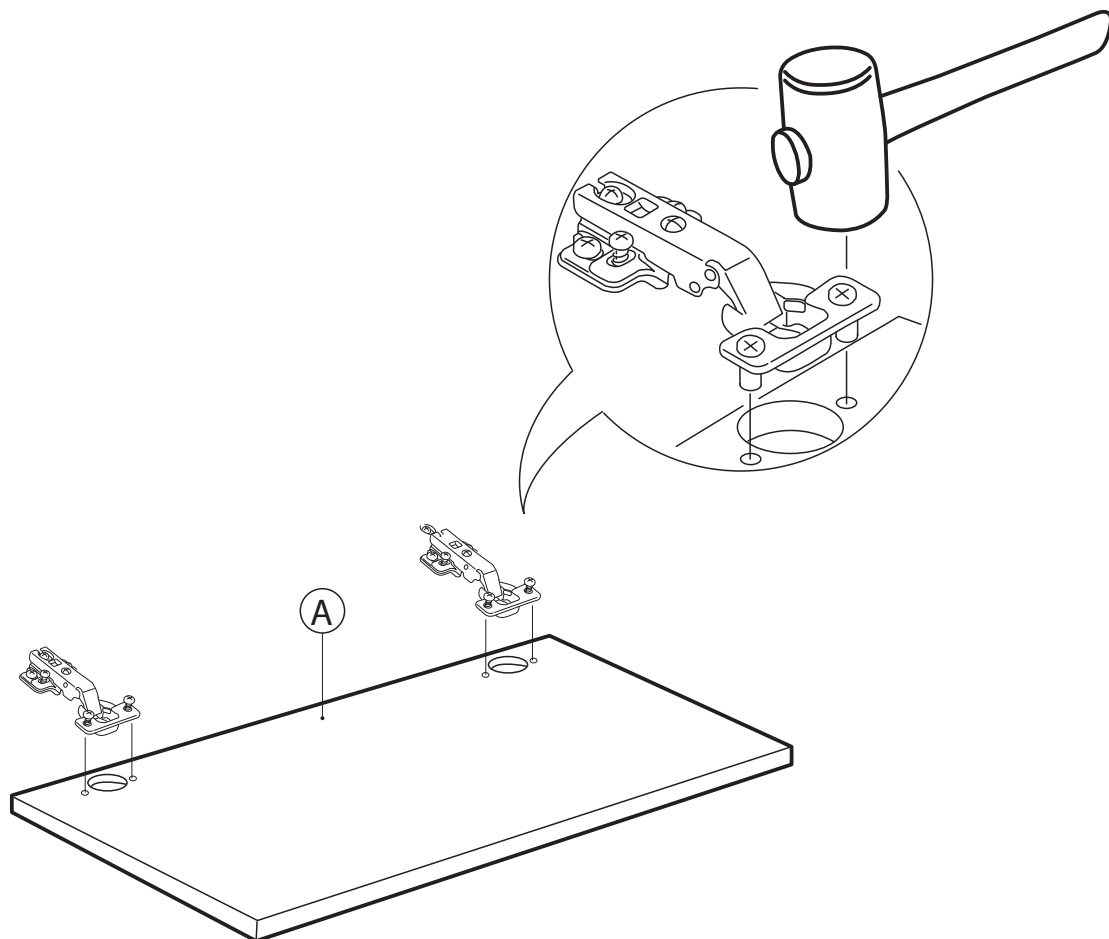

7.

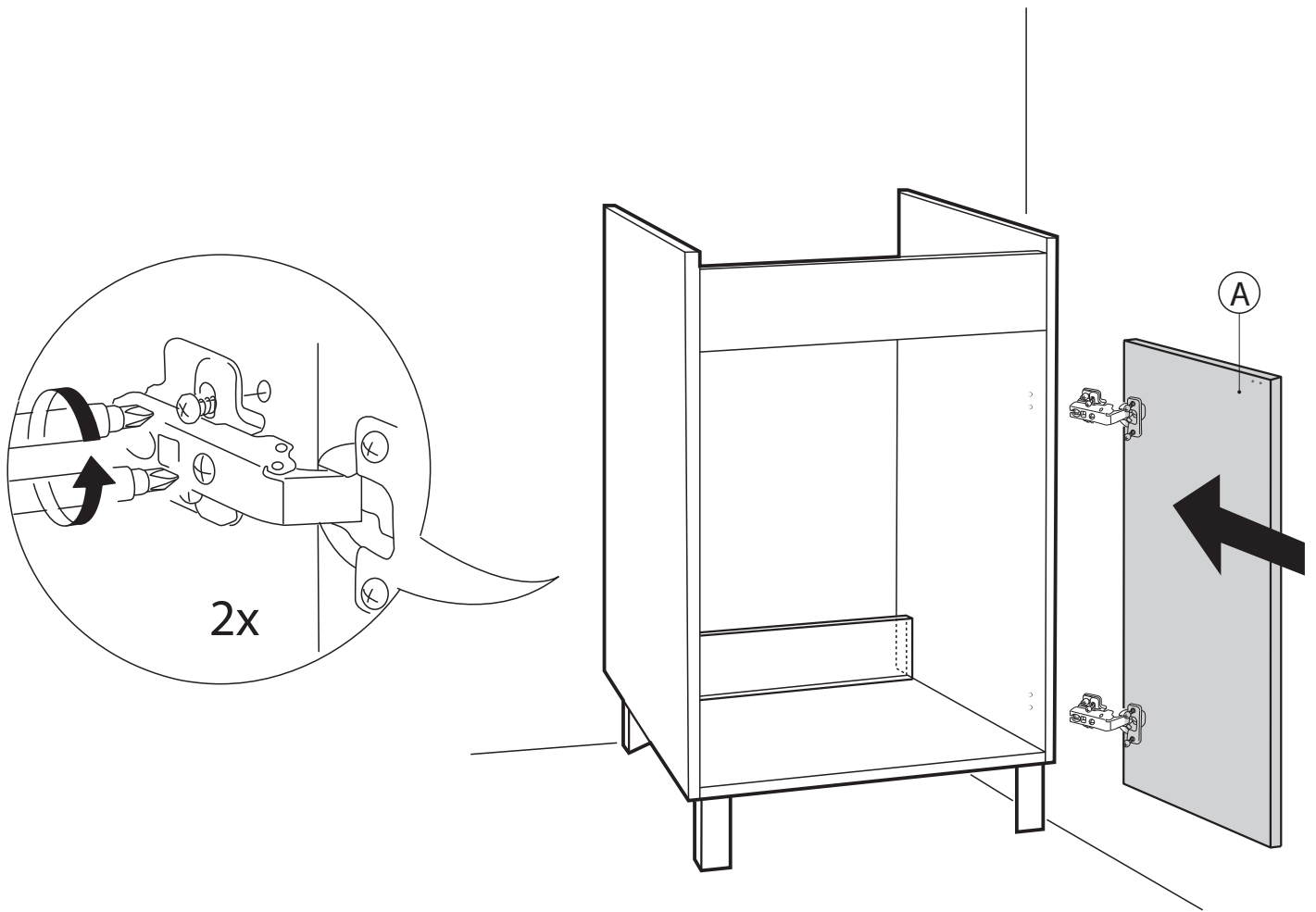

8.



9. MONTAGGIO MANIGLIE / HANDLES FIXING

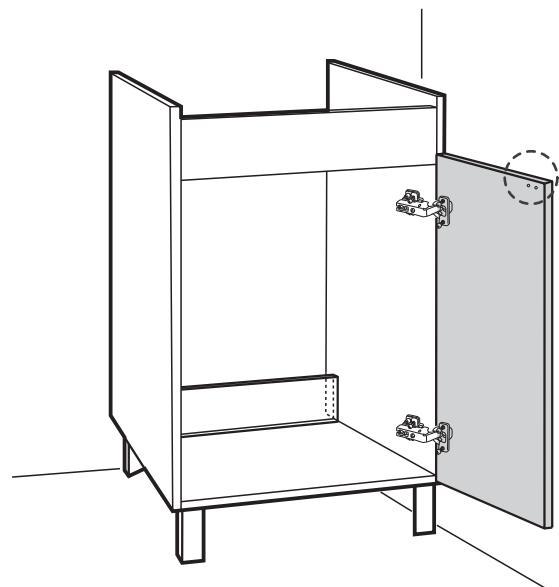
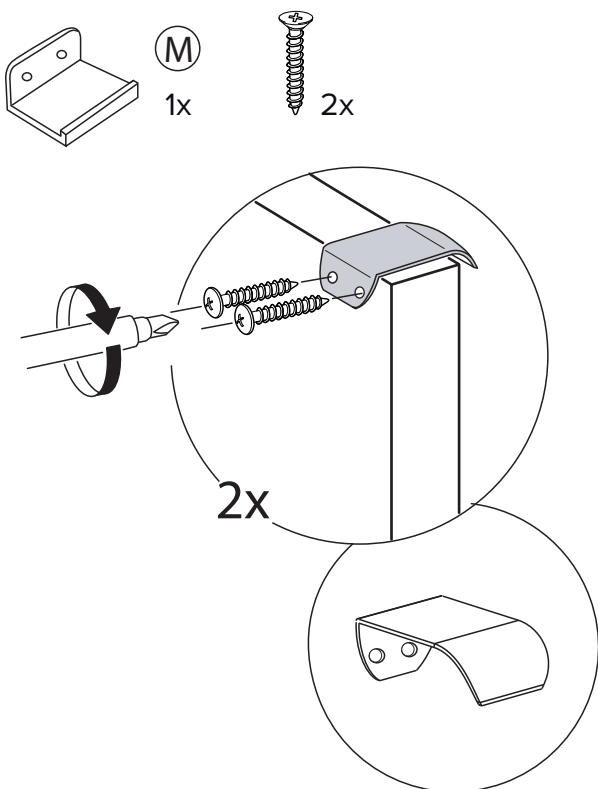

REGOLAZIONE ANTE / DOORS REGULATION

Regolazione verticale/Vertical adjustment

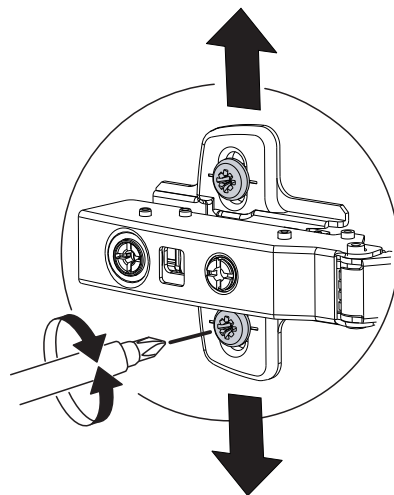
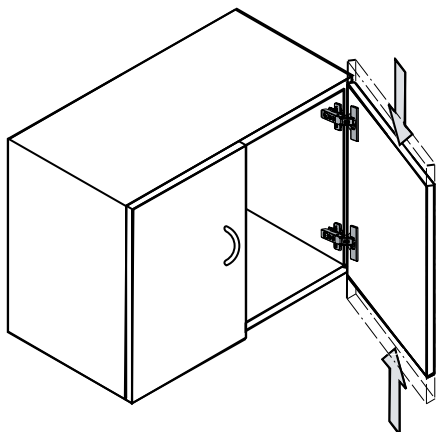

Regolazione sormonto/Overlapping adjustment

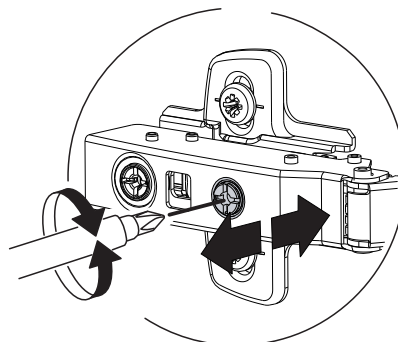
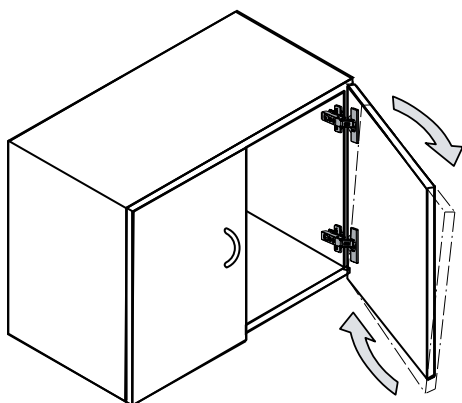

Regolazione profondità/Depth adjustment

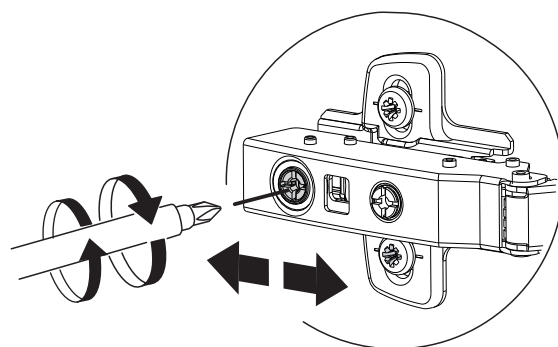
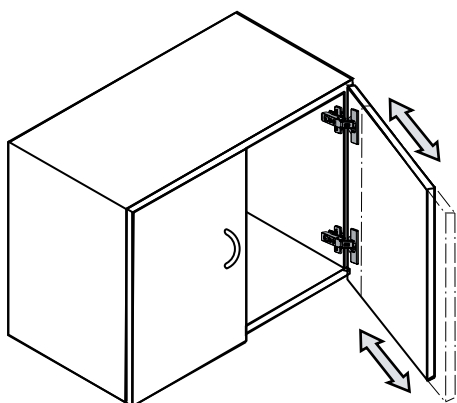

INSTALLAZIONE VASCA E SIFONE / BASIN AND SIPHON INSTALLATION

Biadesivo per fissare il lavatoio / Double sided tape to fix basin

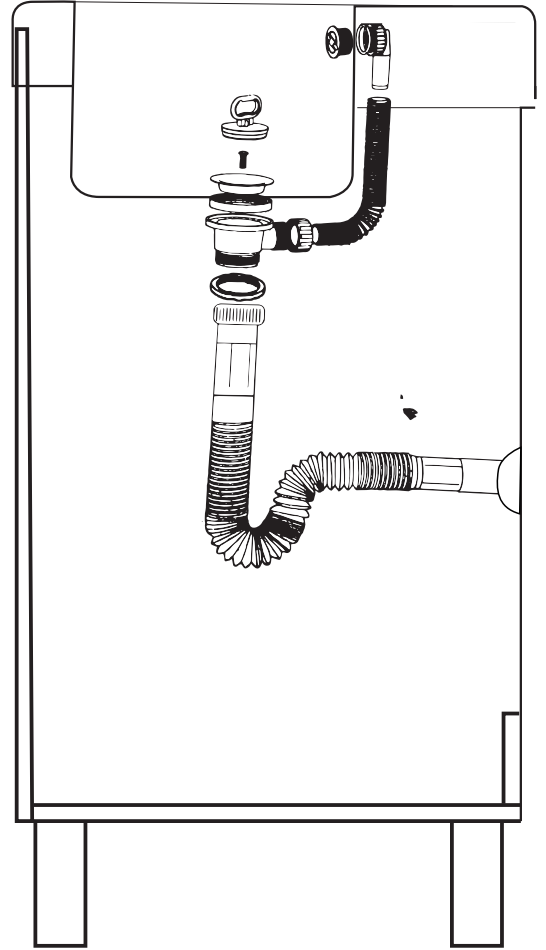
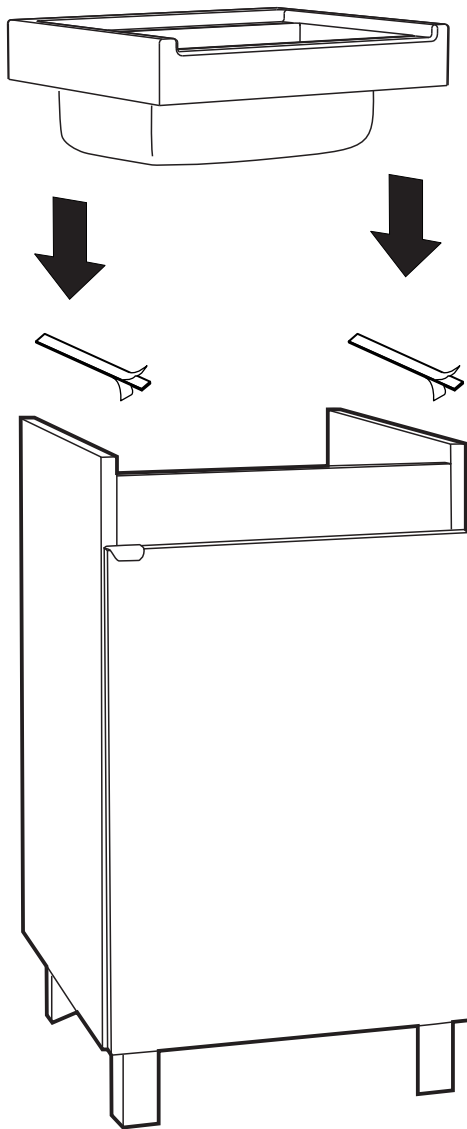

ATTENZIONE ATTENTION

PER EVITARE DANNI SUL LAVATOIO
*To avoid damage to the washtub follow the
instructions below:*



PILETTA TP / drain

SCARICO / tube

Non usare pasta sigillante o silicone per il
montaggio della piletta!
EVITARE l'uso di utensili elettrici o
pneumatici per serrare la componentistica.
*Do not use sealing paste or silicone for
mounting the drain!
Avoid using electric or pneumatic tools to fix
the components.*

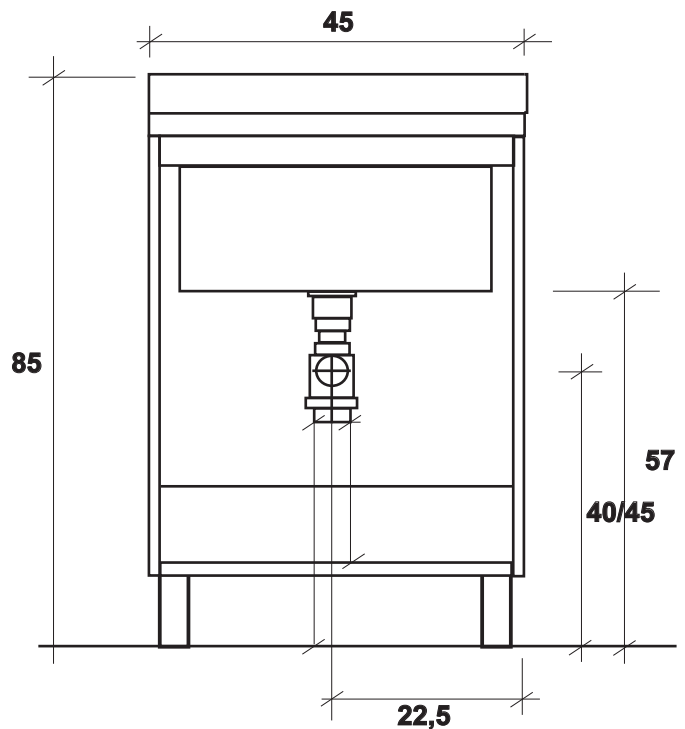

IT**IMPORTANTE**

Prima del montaggio leggere attentamente le istruzioni. Assicurarsi che l'imballo sia integro e che contenga tutti i componenti necessari al montaggio e che gli stessi non presentino difetti.

SICUREZZA

I limiti di carico indicati nelle istruzioni di montaggio si riferiscono ad un carico massimo uniformemente distribuito sulla struttura montata rispettando le indicazioni delle Istruzioni di Montaggio. Caricare il mobile solo in modo manuale, non usare mezzi meccanici. Non caricare la struttura oltre i limiti indicati, il prodotto o parti di esso possono subire deformazioni e rotture.

MANUTENZIONE

Pulire periodicamente con un panno umido e saponi o detersivi liquidi neutri. Evitare l'uso di alcool o di detersivi contenenti sostanze solventi o in generale corrosive. Evitare l'uso di abrasivi. Controllare periodicamente che la struttura non abbia subito deformazioni o danni. Sostituire immediatamente le parti danneggiate o deformate.

INFORMAZIONI TECNICHE E LEGALI

Evitare di posizionare il prodotto in prossimità di fonti di calore. Evitare di posizionare oggetti caldi a contatto con il prodotto.

La portata massima del prodotto è garantita per l'uso in ambienti con condizioni normali di temperatura (-5°C e +40°C)

Le parti in resina esposte alla luce solare possono nel tempo subire variazioni nella tonalità dei colori e nella resistenza.

Il prodotto non è adatto alla conservazione di materiali solventi o corrosivi. Non adatto alla conservazione di alimenti. Evitare usi impropri e non consoni al prodotto. Non salire in piedi sul prodotto. Il costruttore declina ogni responsabilità per danni causati a cose o persone da un uso non corretto del prodotto o causati da un prodotto montato non rispettando le istruzioni di montaggio e le avvertenze d'uso.

CONDIZIONI DI VALIDITÀ DELLA GARANZIA

La Garanzia è valida solo se comprovata dal documento di acquisto originale.

Il prodotto è garantito sul territorio dell'Unione Europea per 2 anni (compresa la garanzia biennale prevista dalla direttiva 99/44/CE, recepita in Italia con il decreto legislativo del 2 febbraio 2002, n.24) dalla data di acquisto in condizioni normali d'uso.

La garanzia decade automaticamente nei seguenti casi:

- danni causati dall'utilizzo di prodotti non idonei per la pulizia
- la sostituzione completa del prodotto
- se il servizio di funzionamento è conseguente ad un intervento sul prodotto non autorizzato
- se il funzionamento difettoso è conseguente alla normale usura del prodotto, alla negligenza o incuranza da parte dell'acquirente
- se il funzionamento difettoso è conseguente a forze maggiori
- manomissione del prodotto da parte dell'acquirente
- se il montaggio non è stato eseguito secondo istruzioni

EN**IMPORTANT**

Before the assembly, read carefully the instructions. Make sure that the packing is safe and it contains all the components necessary for the assemblage and at the same they have no defects.

SAFETY

The load limits stated in the assembly instructions refer to a maximum load distributed evenly on the structure assembled following the Assembly Instructions. Load the cabinet only manually, do not use mechanical equipment. Do not load the structure above the stated limits, the product or parts of it may warp or break.

MAINTENANCE

Clean regularly with a damp cloth and neutral soap or detergent. Do not use alcohol or detergents containing solvents or corrosive substances in general. Do not use abrasives. Check the structure regularly for warps or damage. Replace any damaged or warped parts immediately.

TECHNICAL AND LEGAL INFORMATION

Do not position the product near sources of heat. Do not place hot objects where they touch the product.

The maximum capacity if the product is guaranteed for use where ambient temperatures are normal (-5°C to +40°C)

Exposure to sunlight may cause the epoxy resin parts to change colour lose some strength. The product is not suitable for keeping solvents or corrosive materials. It is not suitable for storing foodstuffs. Avoid improper or inappropriate use. Do not stand on the product. The manufacturer declines all liability for personal injury or damage to property caused by improper use of the product or if it is assembled without following the assembly instructions and recommendations for use.

GUARANTY VALIDITY CONDITIONS

The guaranty is valid only if confirmed by the original sales document.

The product is guaranteed throughout the territory of the European Union for 2 years (including the two-year guarantee required by directive 99/44/CE, implemented in Italy by legislative decree n.24 of 2 February as of the purchase date and in normal conditions of use.

The guarantee is void in the following cases:

- damage caused by product not suitable for cleaning
- complete replacement of the product
- if the service operation is a result of intervention on the unauthorized product
- if the defect is a result of normal wear and tear, negligence or negligence by the buyer
- if the defect is a result of force major
- tampering of product by the buyer
- if the installation was not performed according to instructions

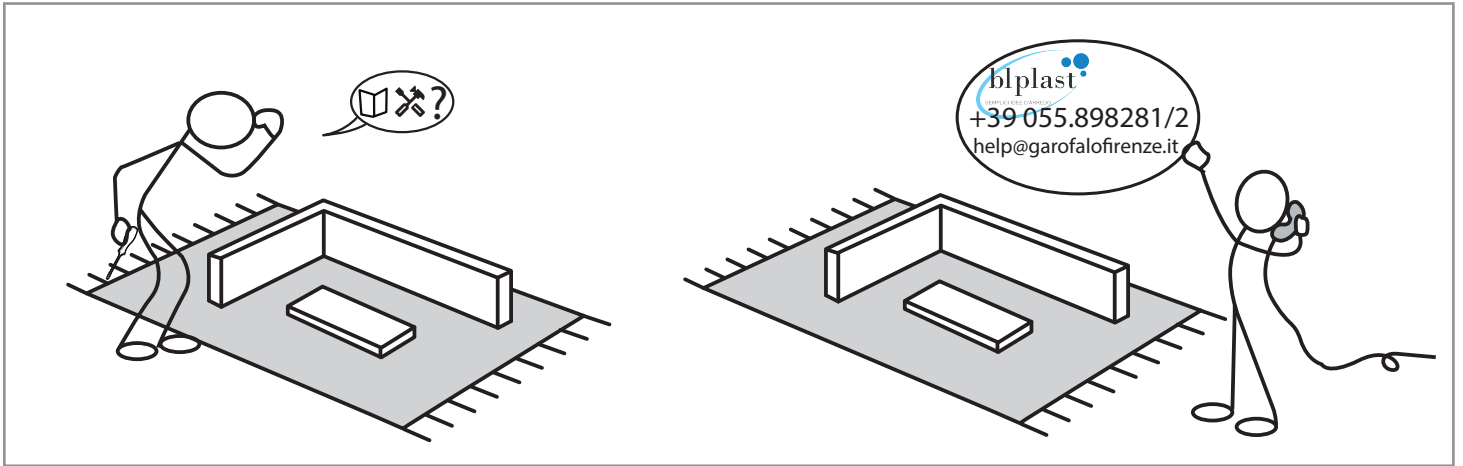
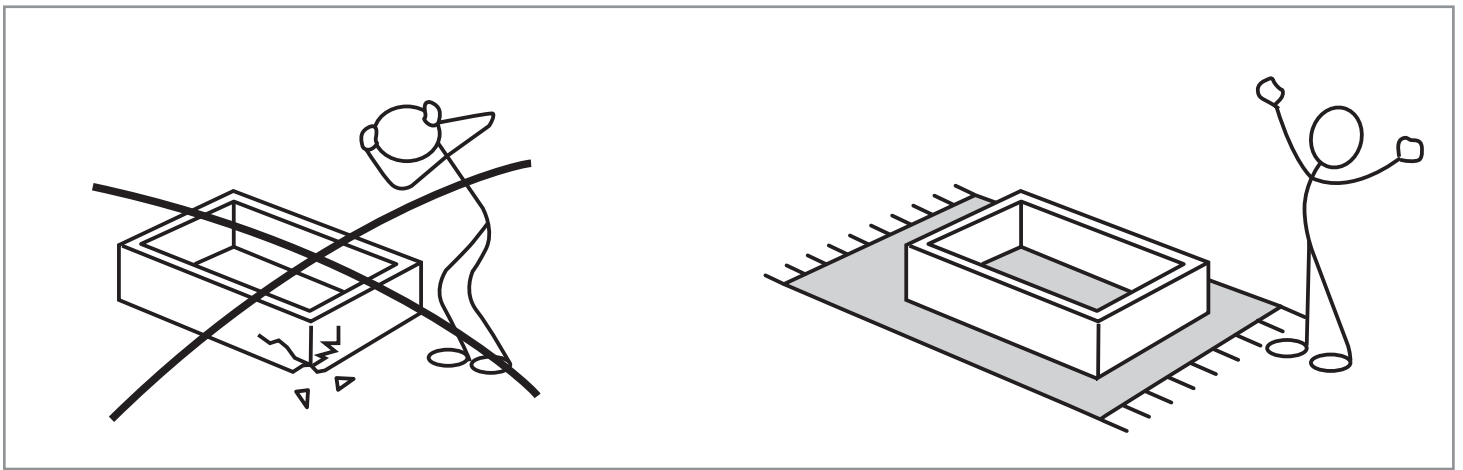

Per assistenza al montaggio, o per richiedere pezzi di ricambio, accedi al nostro sito nell'area contatti, scrivi un'email a help@garofalofirenze.it oppure chiama il numero **+39 055. 898281/2**

NON RESTITUIRE IL PRODOTTO AL NEGOZIO.

For assistance with assembly, or to request replacement parts, access our website in the contact area, write an email to help@garofalofirenze.it or call **+39 055. 898281/2**

DO NOT RETURN THE PRODUCT TO THE STORE.

Si vous avez besoin d'aide pour le montage, ou pour demander des pièces de rechange, accédez à notre website dans la zone de contact, écrivez un email à help@garofalofirenze.it, or call **+39 055. 898281/2**

NE RETOURNEZ PAS LE PRODUIT AU MAGASIN.

Para obtener ayuda sobre el montaje o para solicitar piezas de repuesto, conéctese a nuestro website en el área de contacto, escriba un correo electrónico a help@garofalofirenze.it o llamar **+39 055. 898281/2**

NO DEVUELVA EL PRODUCTO A LA TIENDA.

Wenn Sie Hilfe beim Aufbau oder Ersatzteile benötigen, greifen Sie auf unsere Website im Kontaktbereich zu und schreiben Sie eine E-Mail an help@garofalofirenze.it oder anrufen **+39 055. 898281/2**

GEBEN SIE DAS PRODUKT NICHT IM GESCHÄFT ZURÜCK.



MADE IN ITALY

BLplast

Via Pietro Nenni, 3
Campi Bisenzio (FI), 50013 - ITALY
tel. +39 055 898281/2
fax +39 055 8969013
email: info@garofalofirenze.it

www.garofalofirenze.it

M05.04.086 - 03/2023