

& Inspire

BARBADE

EAN : 3276007345513
Ref: J36002-XY-1L(WM)

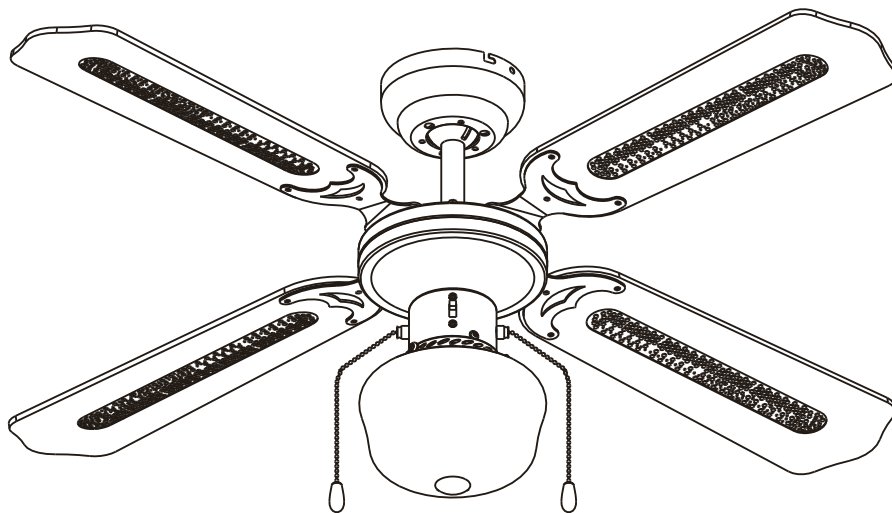

2/2



2025-01-V01

FR Manuel d'Instructions

EL Εγχειρίδιο Οδηγιών

BR Manual de Instrução

ES Manual de Instrucciones

PL Instrukcja Obsługi

DE Anleitung Handbuch

PT Manual de Instruções

UA Інструкція з Експлуатації

EN Instructions Manual

IT Manuale di Istruzioni

RO Manual de Instrucțiuni

*Année de garantie / años de garantía / Ano de garantia / Anno di garanzia / Έτος εγγύησης / Rok gwarancji / Гарантія років / Anul de garanție / Anos de garantía / Jahr der Garantie / Year of guarantee

**réparable / reparable / reparável / riparabile / διορθώσιμος / naprawiany / ремонтний / reparabil / reparaturfähig / reparável / repairable



FR : Montage / ES: Montaje / PT: Montagem / IT: Montaggio / EL: Συναρμολόγηση /
 PL: Montaż / UA: Збірка / RO: Montaj / BR: Montagem / DE: Montage / EN: Assembly







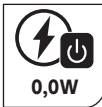
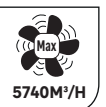
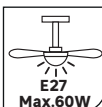

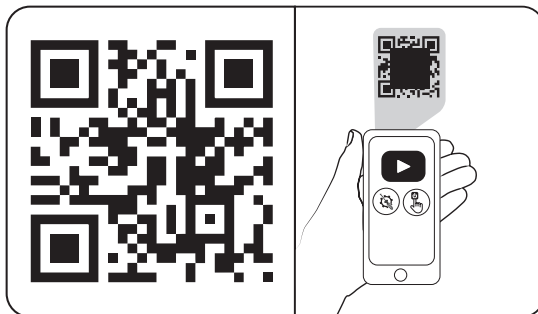
FR: Utilisation / ES: Utilización / PT: Utilização / IT: Uso / EL: Χρήση / PL: Użytkowanie
 / UA: Використання / RO: Utilizare / BR: Utilização / DE: Verwenden Sie / EN: Use

FR: CARACTÉRISTIQUES TECHNIQUES / ES: CARACTERÍSTICAS TÉCNICAS / PT: CARACTERÍSTICAS TÉCNICAS / IT: CARATTERISTICHE TECNICHE / EL: ΤΕΧΝΙΚΑ ΧΑΡΑΚΤΗΡΙΣΤΙΚΑ / PL: DANE TECHNICZNE / UA: ТЕХНІЧНІ ХАРАКТЕРИСТИКИ / RO: CARACTERISTICI TEHNICE / BR: CARACTERÍSTICAS TÉCNICAS / DE: TECHNISCHE CHARAKTERISTIKA / EN: TECHNICAL CHARACTERISTICS





FR : Scanner ce code QR pour voir la vidéo de montage
ES : Escanear este código QR para ver el video de montaje
PT : Digitalize este código QR para ver o vídeo de montagem
IT : Scannerizza questo codice QR per vedere il video di montaggio
EL : Σαρώστε τον συγκεκριμένο κωδικό QR για να δείτε το βίντεο συναρμολόγησης
PL : Zeskanuj ten kod QR, aby zobaczyć wideo montażowe
UA : Відскануйте цей QR-код, щоб переглянути відео про монтаж
RO : Scațați acest cod QR pentru a viziona videoclipul de montaj
BR : Escanear este código QR para ver o vídeo de montagem
NL : Scan deze QR-code om de montagevideo te bekijken
DE : Scannen Sie diesen QR-Code, um das Montagevideo anzusehen
EN : Scan this QR code to view the assembly video

	1	2	3
	31,5	34,7	44,3
	176	269	308
	2570	4590	5740
	1,4	2,2	2,2
	44,0	47,3	51,6

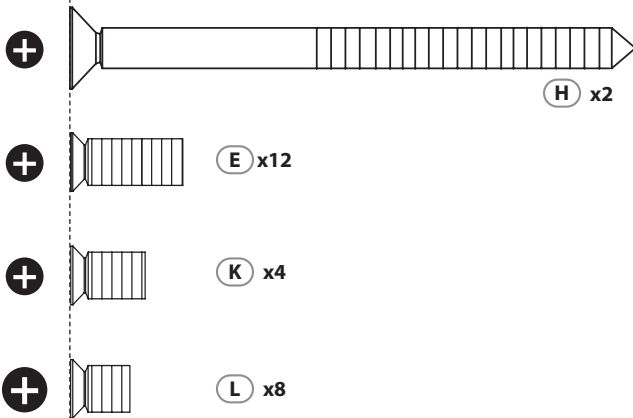
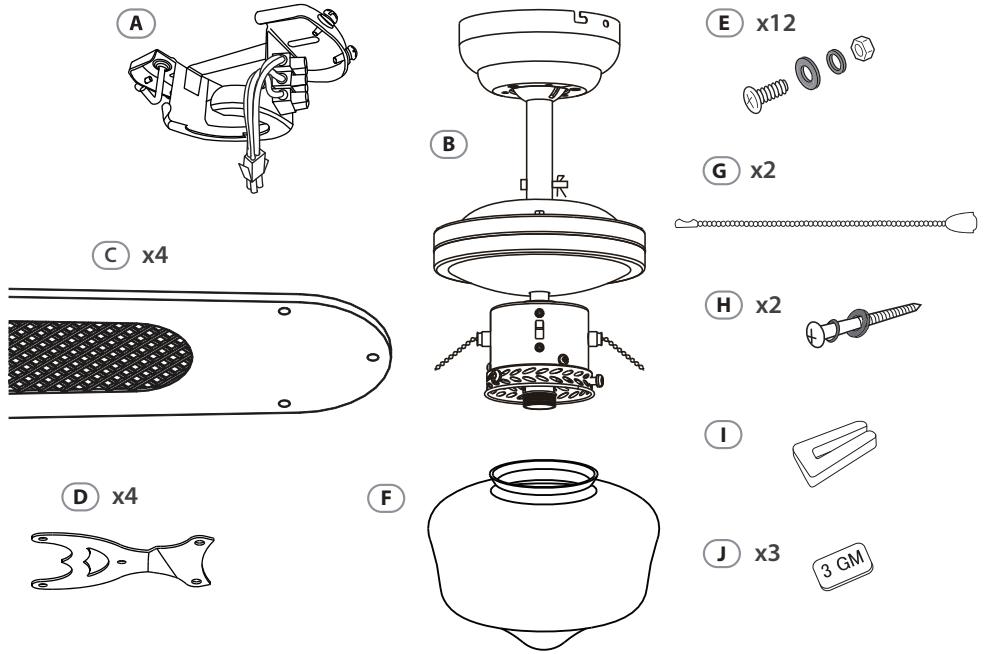

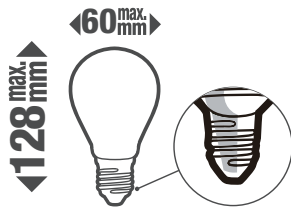
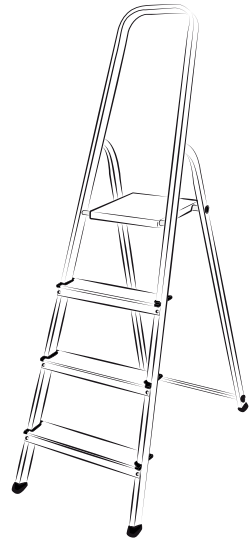
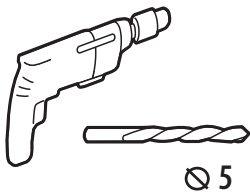

E27 MAX 60W

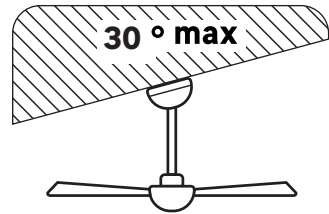
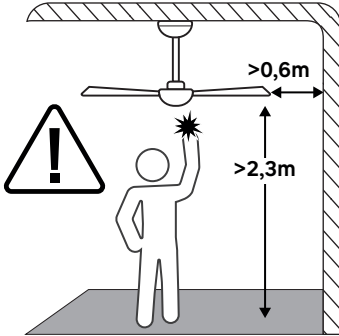
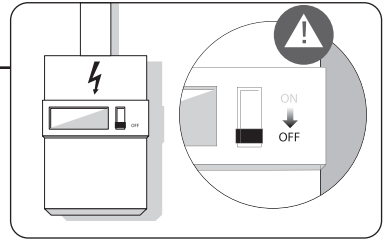

1

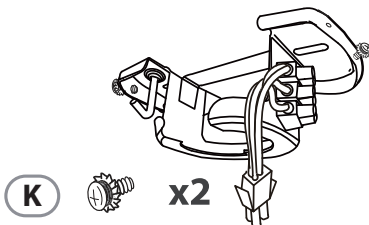
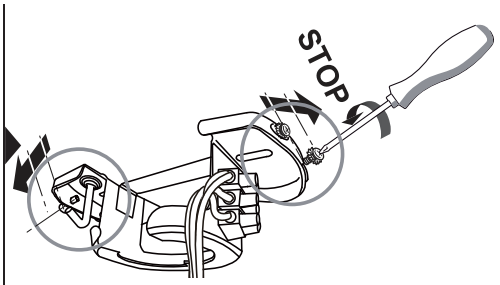
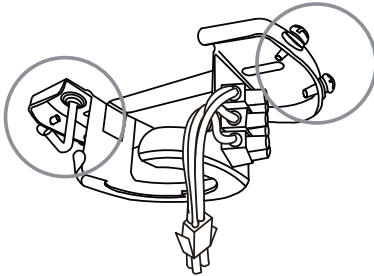

(K)  x2

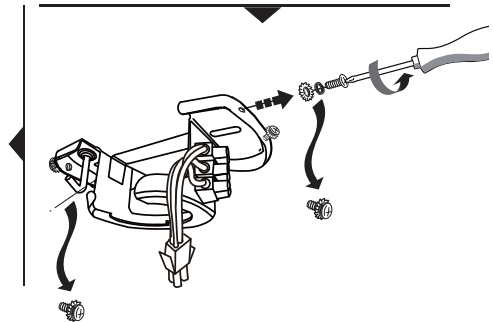



2

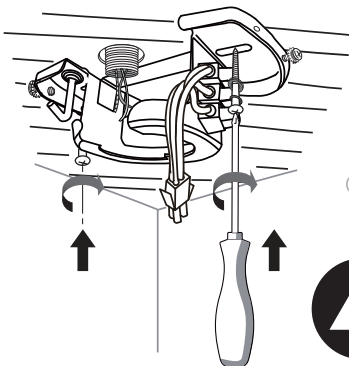

OR

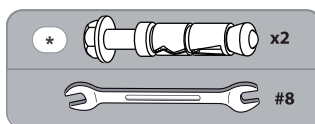
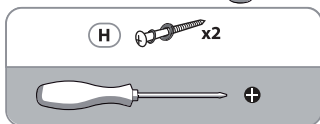
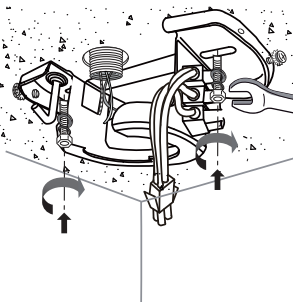

FR - fixé avec une résistance suffisante pour résister à 4 fois le poids du ventilateur de plafond / **ES** - fijado con una resistencia suficiente para soportar 4 veces el peso del ventilador de techo / **PT** - fixado com uma resistência suficiente para suportar 4 vezes o peso do ventilador de teto / **IT** - fissato con una resistenza sufficiente per resistere a 4 volte il peso del ventilatore a soffitto / **GR** - στερεωμένο με επαρκή αντοχή για να αντέξει 4 φορές το βάρος του ανεμιστήρα οροφής / **PL** - przymocowany z wystarczającą wytrzymałością, aby wytrzymać 4 razy ciężar wentylatora sufitowego / **UA** - закріплення з достатньою міцністю, щоб витримати 4-кратний вагу стельового вентилятора / **RO** - fixat cu o rezistență suficientă pentru a rezista la 4 ori greutatea ventilatorului de tavan / **BR** - fixado com uma resistência suficiente para suportar 4 vezes o peso do ventilador de teto / **NL** - bevestigd met voldoende sterkte om 4 keer het gewicht van de plafondventilator te weerstaan / **DE** - mit ausreichender Festigkeit befestigt, um 4-mal das Gewicht des Deckenventilators zu tragen / **EN** - fixed with sufficient strength to withstand 4 times the weight of the ceiling fan

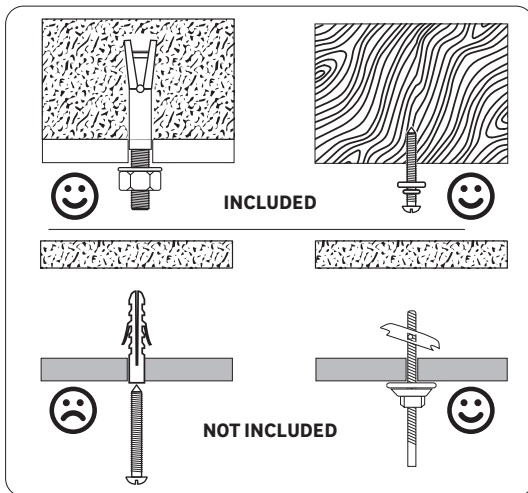
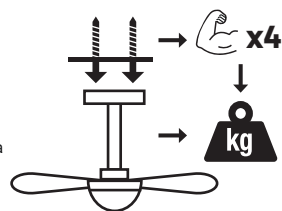

FR - Utiliser des vis et des chevilles adaptées à votre support. / **ES** - Utilice tacos y tornillos adecuados al soporte. / **PT** - Utilize buchas e parafusos adequado ao seu suporte. / **IT** - Utilizzare viti e tasselli adatti per il retro. / **GR** - Χρησιμοποιήστε βίδες και βύσματα που ταίριαζουν στην επιφάνεια στήριξης. / **PL** - Należy użyć śrub i kołków odpowiednich dla podłoża. / **UA** - Використовуйте гвинти та шканти, призначені для задньої поверхні. / **RO** - Utilizați șuruburi și dibluri adecvate pentru suportul dvs. / **BR** - Use parafusos e buchas adequados para seu suporte. / **NL** - Gebruik schroeven en pluggen die geschikt zijn voor uw ondergrond. / **DE** - Verwenden Sie für Ihre Unterlage geeignete Schrauben und Dübel. / **EN** - Use screws and dowels suited to your backing.



3

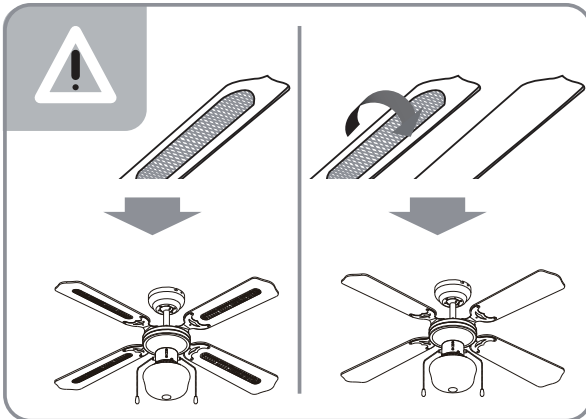
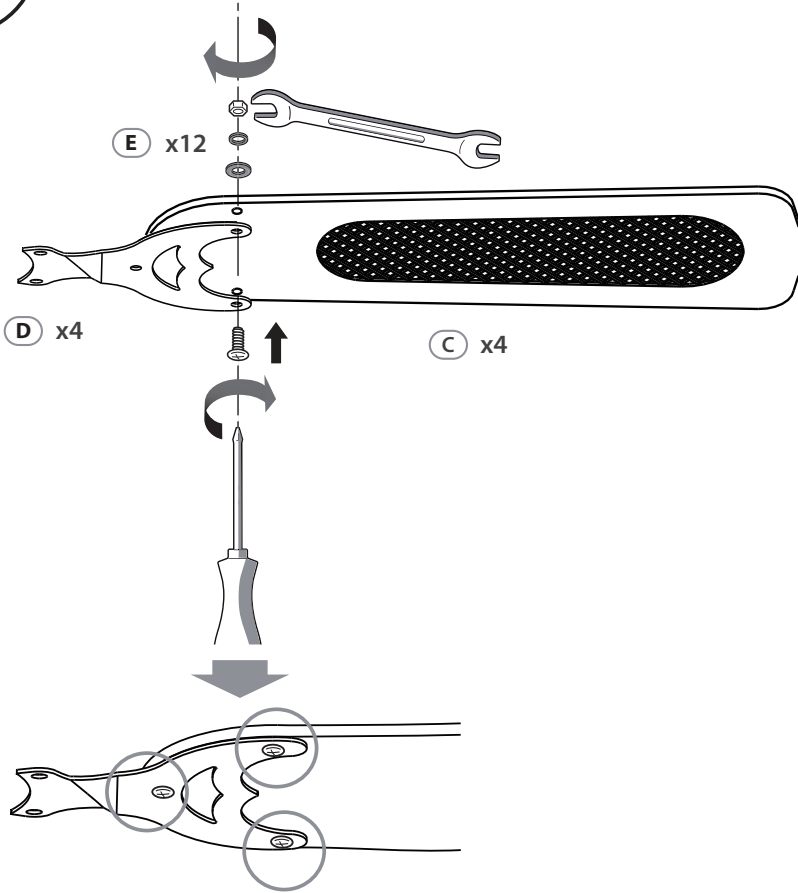

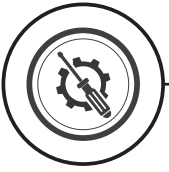

4

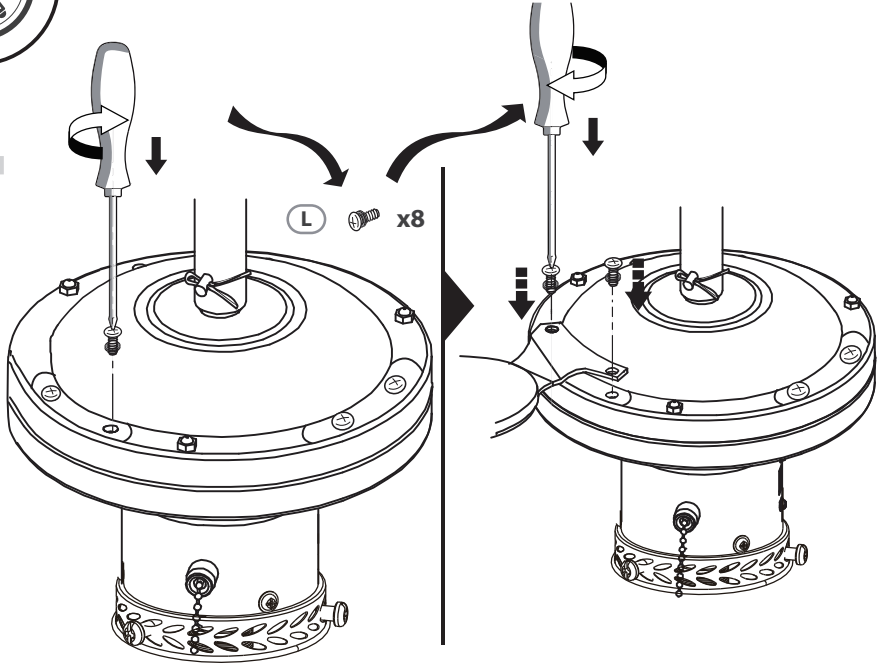

5

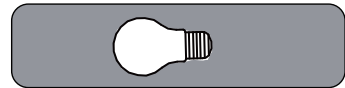
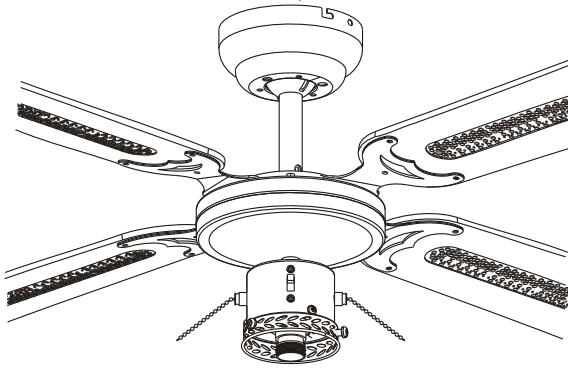



6

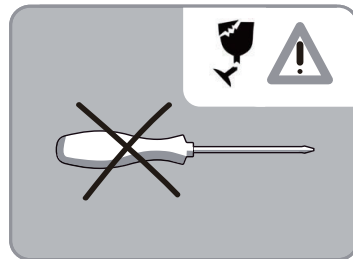
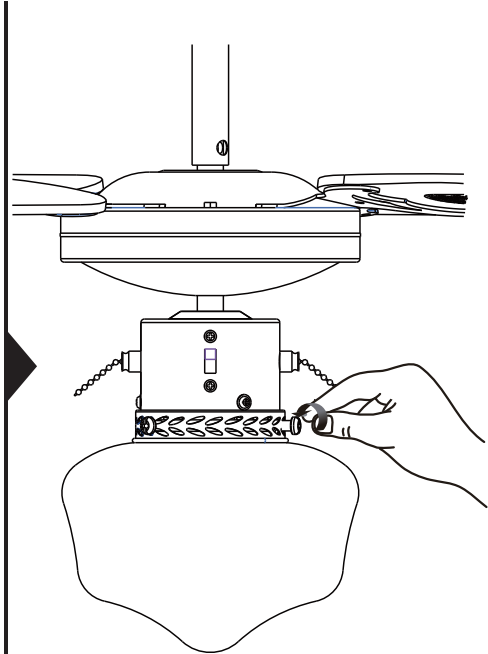
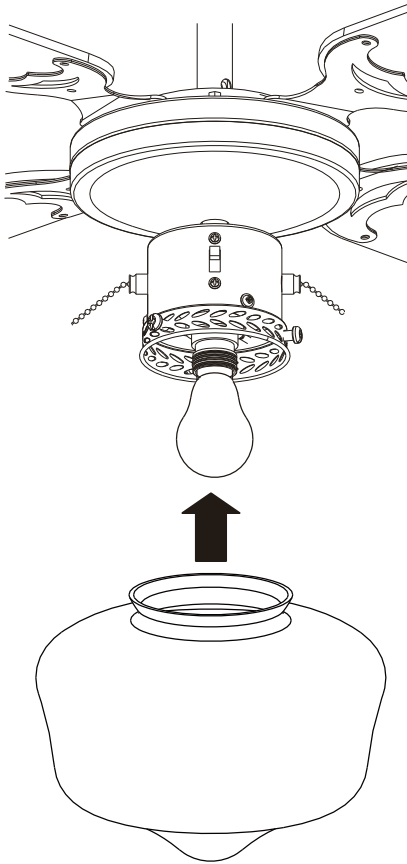

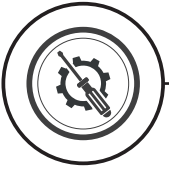

7

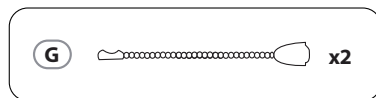
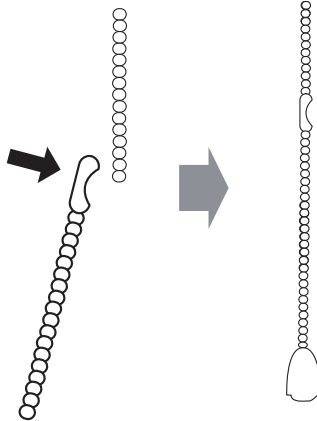
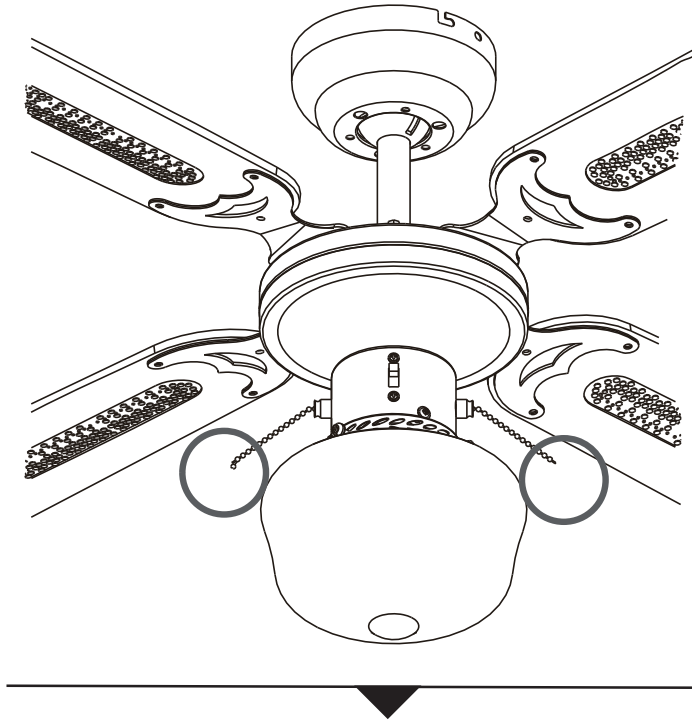



8

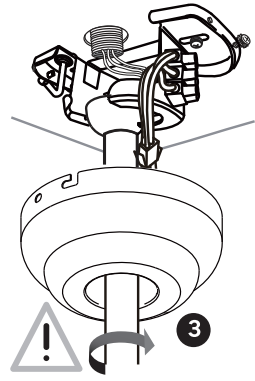
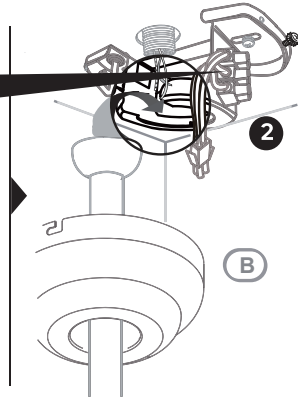
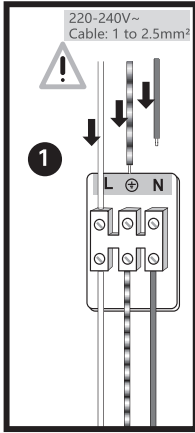

L=Marron/Marrón/Castanho/Marrone/
Кафе/Brazowy/Коричневый/Қоңыр/
Коричневий/Maro/Castanho/Brown

N=Bleu/Azul/Azul/Blu/Μπλε/
Niebieski/Синий/Көк/
Синий/Albastru/Azul/Blue

⊕=Vert/Verde/Verde/Verde/
Πράσινος/Zielony/Зеленый/
Жасыл/Зеленый/Verde/
Verde/Green

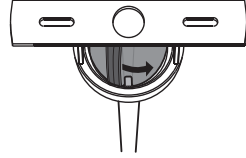
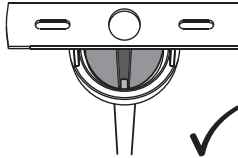



9

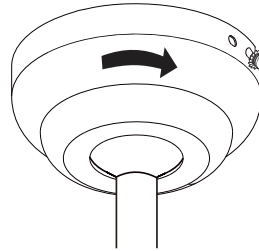
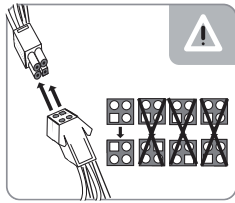
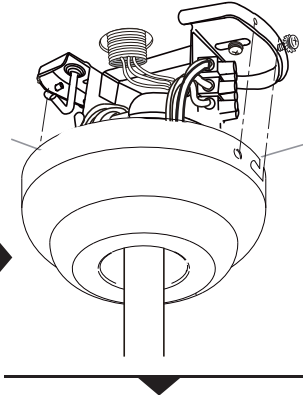
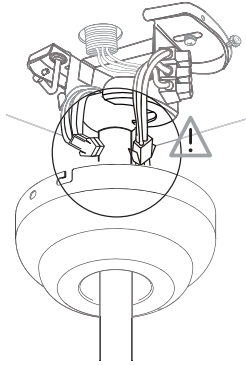

10

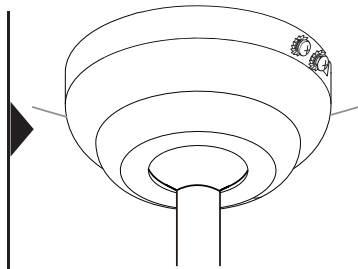
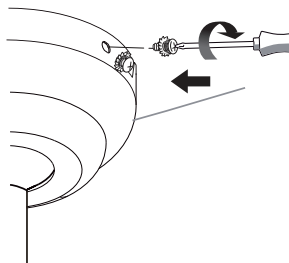
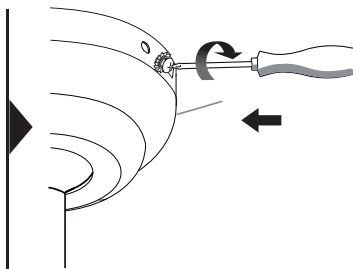
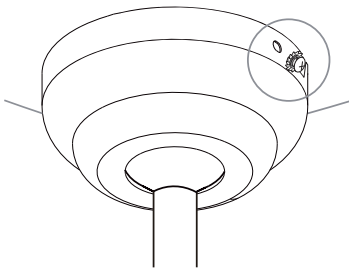

K  x2

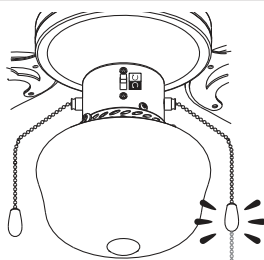

ON/OFF

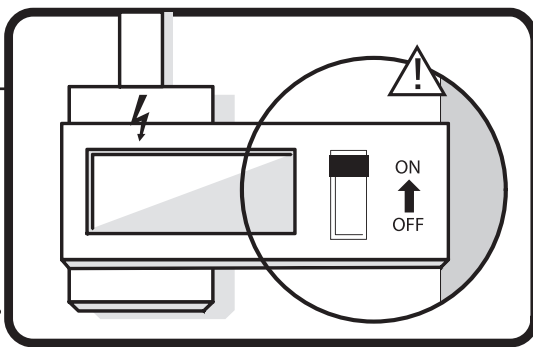

Lumière seulement/Solo luz/Apenas luz/Solo luceΜόνο φως/ Tyłko światło/ Тільки світло/Doar lumina/Alleen licht /Nur Licht/**Light only**

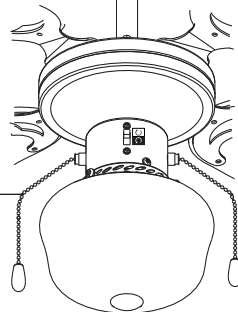
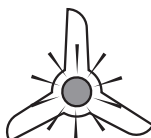

1

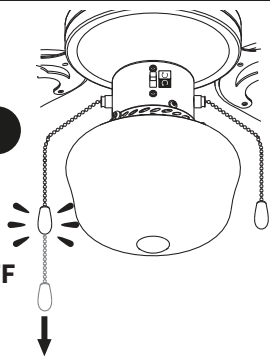

ON/OFF

2

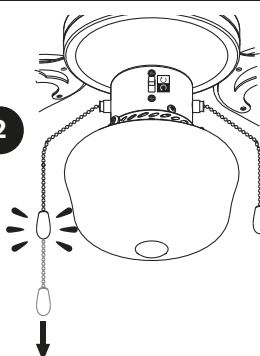

1 - 2 - 3



Vitesse/Velocidad/Velocidade/Velocità /Ταχύτητα/Prędkość/Швидкість/Víteza /Snelheid/Geschwindigkeit/Speed

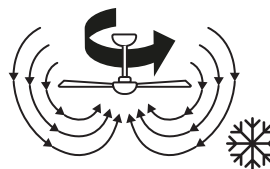
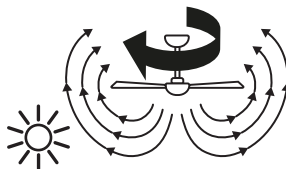
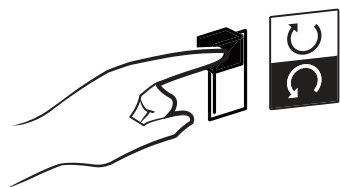

Été/Hiver- Verano/Invierno - Verão/Inverno - Estate/Inverno - Καλοκαίρι/Χειμώνας - Lato/Zima - Літо/Зима - Ará/larná - Zomer/Winter - Sommer/Winter - Summer/Winter

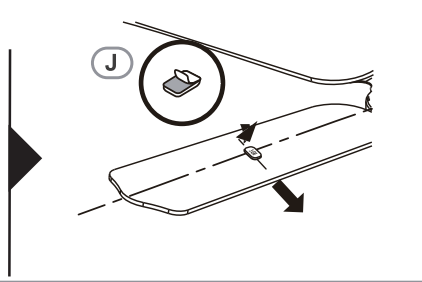
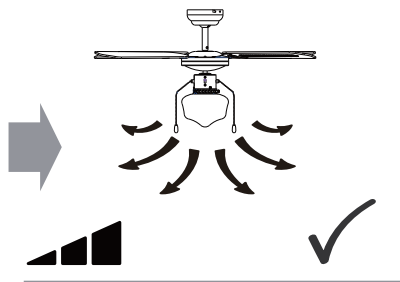
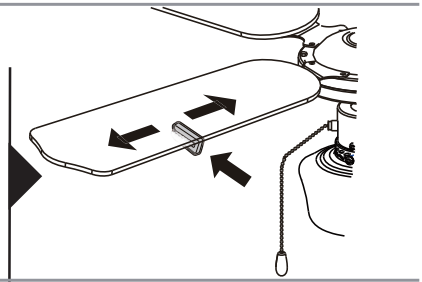
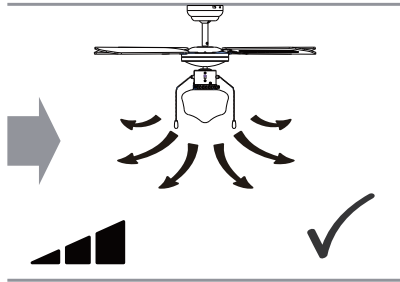
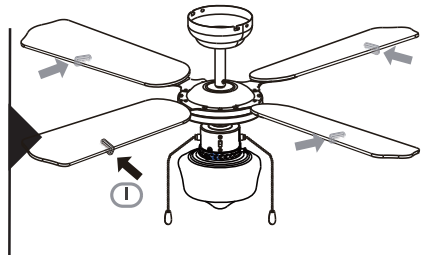
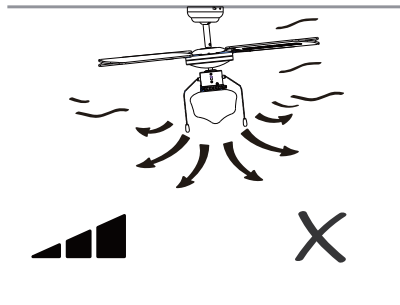
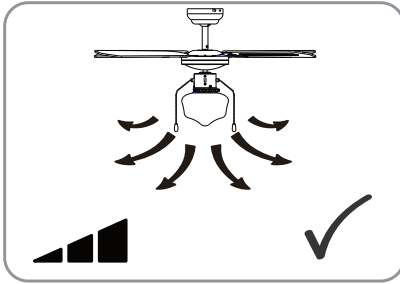



Made in China
Країна походження: Китай

EU - ADEO Services - 135 Rue Sadi Carnot - CS00001 - 59790 RONCHIN - FRANCE
www.product-regulatory.adeoservices.com

UA Виробник: ТОВ "Адео Сервісез С.А.", вул. Саді Карно, CS 00001, 59790 Роншен, Франція.
Імпортер, суб'єкт господарювання, що відповідає за виконання гарантійних

BR LEROY MERLIN COMPANHIA
BRASILEIRA DE BRICOLAGEM CNPJ:
01.438.784/0001-05
Rua Pascoal Pais, nº. 525, 6º andar cj
61 a 64, Vila Cordeiro, São Paulo -SP.
CEP: 04581-060

ZA Imported by Adeo South Africa (PTY) LTD
T/A Leroy Merlin,
Hosted in Leroy Merlin Fourways Store
35 Roos Street, Witkoppen Ext 97,
Sandton, 2191 Johannesburg, Gauteng,

