

Inspire

LORET M

EAN : 3276007691825 / 3276007691801 /
3276007691788 / 3276007691771
Ref : BP48300(WH&WB) / BP48300(WH&LB) /
BP48300(BL&DB) / BP48300(BL&BB)

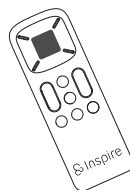
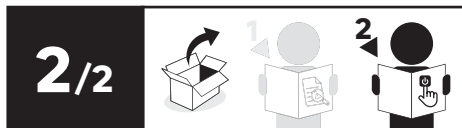
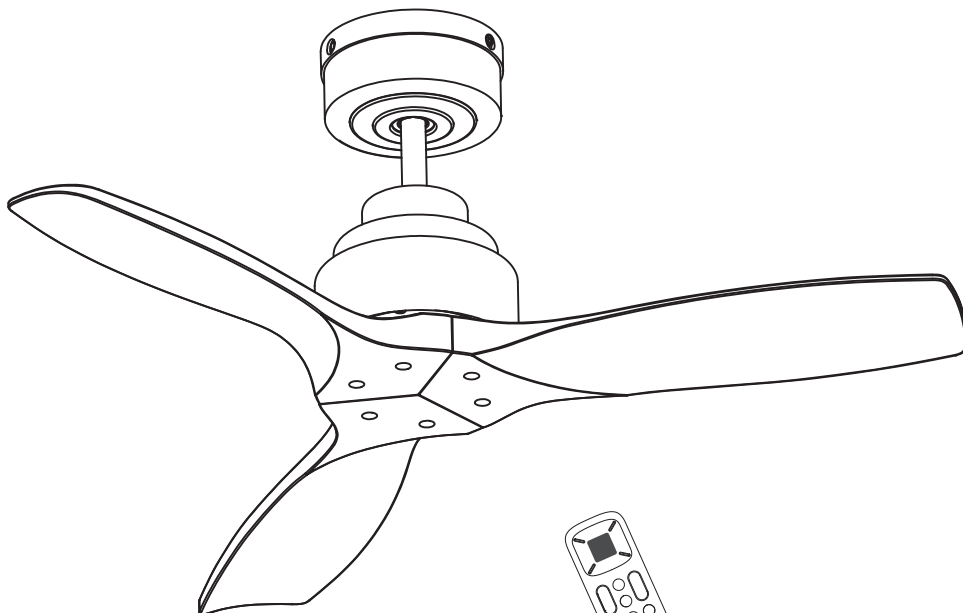

2025-01-V01

FR - Manuel d'Instructions

ES - Manual de Instrucciones

PT - Manual de Instruções

IT - Manuale di Istruzioni

EL - Εγχειρίδιο Οδηγιών

PL - Instrukcja Obsługi

UA - Інструкція з Експлуатації

RO - Manual de Instrucțiuni

BR - Manual de Instrução

NL - Handleiding

DE - Anleitung Handbuch

EN - Instructions Manual

*Année de garantie / años de garantía / Ano de garantia / Anno di garanzia / Έτος εγγύησης / Rok gwarancji / Гарантіяроків / Anul de garanție / Anos de garantía / Garantiejaar / Jahr der Garantie / Year of guarantee

**réparable / reparabile / reparável / riparabile / διορθώσιμος / naprawiany / ремонтний / reparabil / reparaturfähig / reparável / herstelbaar / reparierbar / repairable









FR : assemblage / **ES** : ensamblaje / **PT** : montagem / **IT** : assemblaggio /
EL : συναρμολόγηση / **PL** : montaż / **UA** : збірка / **RO** : asamblare /
BR : montagem / **NL** : samenstelling / **DE** : Montage / **EN** : assembly

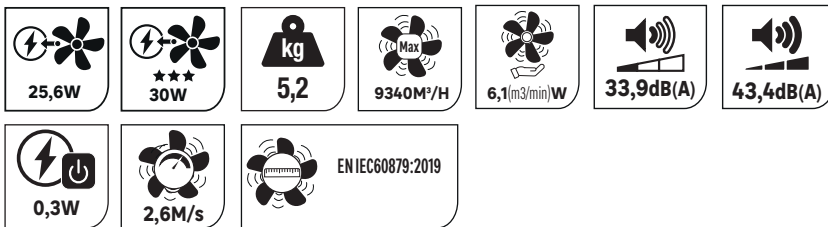
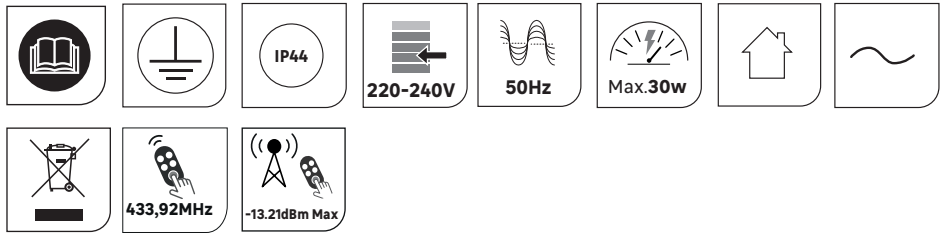

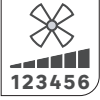
FR : Utilisation / **ES** : Uso / **PT** : Utilização / **IT** : Utilizzo
EL : Χρήση / **PL** : Użycie / **UA** : Використання / **RO** : Utilizare /
BR : Utilização / **NL** : Gebruik / **DE** : Verwendung / **EN** : Use

FR : CARACTÉRISTIQUES TECHNIQUES / **ES** : CARACTERÍSTICAS TÉCNICAS /
PT : CARACTERÍSTICAS TÉCNICAS / **IT** : CARATTERISTICHE TECNICHE / **EL** : ΤΕΧΝΙΚΑ
ΧΑΡΑΚΤΗΡΙΣΤΙΚΑ / **PL** : CECHY TECHNICZNE / **UA** : ТЕХНІЧНІ ХАРАКТЕРИСТИКИ /
RO : CARACTERISTICI TEHNICE / **BR** : CARACTERÍSTICAS TÉCNICAS / **NL** : TECHNISCHE KENMERKEN
/ **DE** : TECHNISCHE MERKMALE / **EN** : TECHNICAL SPECIFICATIONS



	1	2	3	4	5	6
	2,7	5,3	7,9	11,7	17,4	25,6
	71	110	130	153	180	204
	2860	5180	5970	7420	8490	9340
	17,7	16,2	12,6	10,6	8,1	6,1
	33,9	34,2	34,4	36,8	40,8	43,4

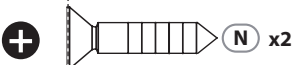
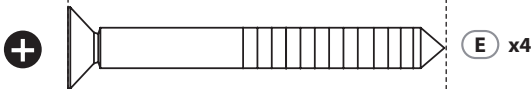
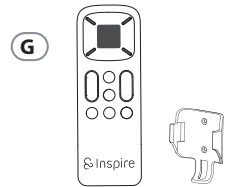
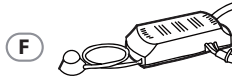
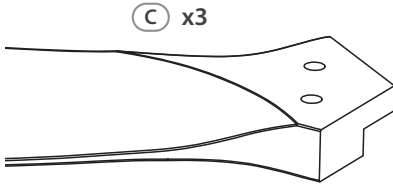
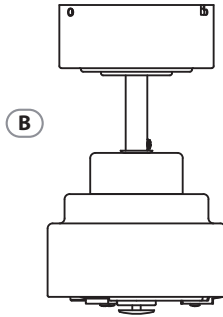
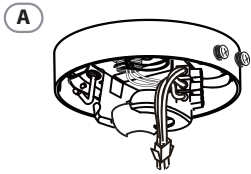

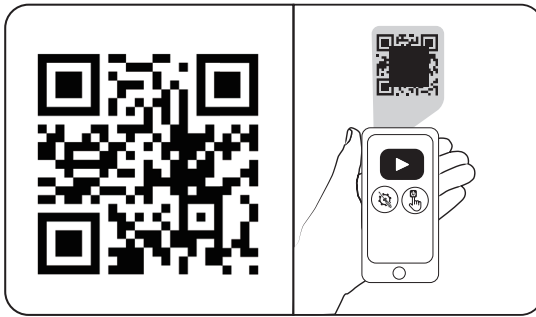

FR : Scanner ce code QR pour voir la vidéo de montage

ES : Escanear este código QR para ver el video de montaje

PT : Digitalize este código QR para ver o vídeo de montagem

IT : Scannerizza questo codice QR per vedere il video di montaggio

EL : Σαρώστε τον συγκεκριμένο κωδικό QR για να δείτε το βίντεο συναρμολόγησης

PL : Zeskanuj ten kod QR, aby zobaczyć wideo montażowe

UA : Відскануйте цей QR-код, щоб переглянути відео про монтаж

RO : Scanați acest cod QR pentru a viziona videoclipul de montaj

BR : Escanear este código QR para ver o vídeo de montagem

NL : Scan deze QR-code om de montagevideo te bekijken

DE : Scannen Sie diesen QR-Code, um das Montagevideo anzusehen

EN : Scan this QR code to view the assembly video

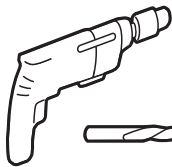

Ø 8



Ø 6



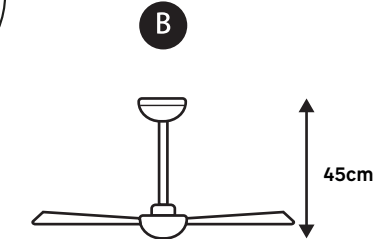
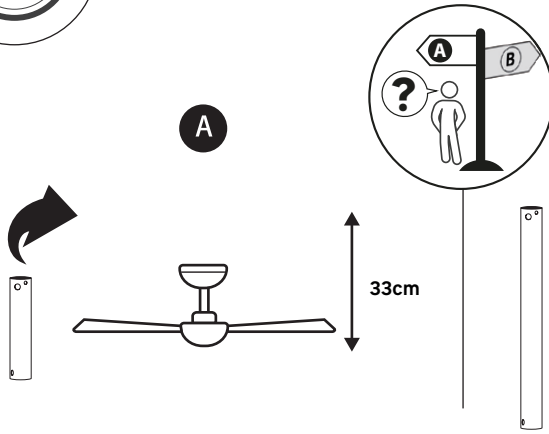
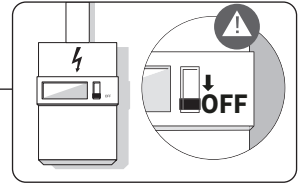

*FR: voir page 13 / ES: ver pàgina 13 / PT: ver pàgina 13 / IT: vedere pagina 13 / EL: δείτε σελίδα 13 / PL: zobacz stronę 13 / UA: див. стор. 13 / RO: vezi pagina 13 / BR: ver página 13 / NL: zie pagina 13 / DE: siehe Seite 17 / EN: see page 13

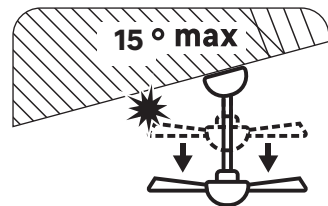
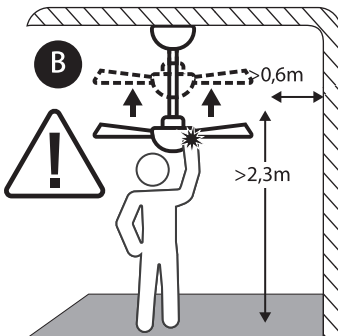
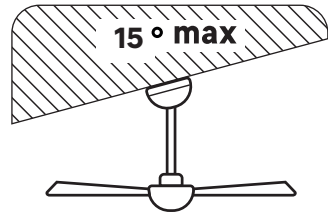
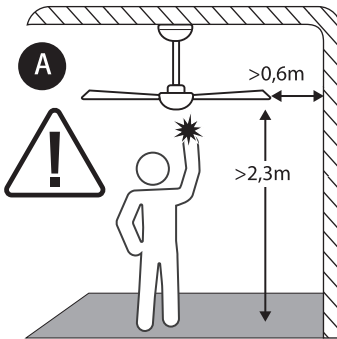



1

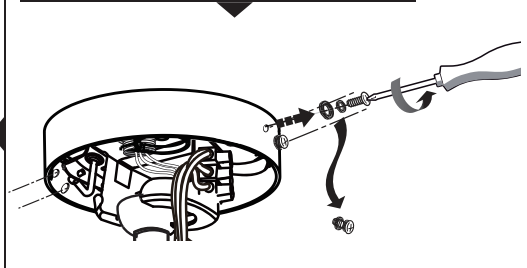
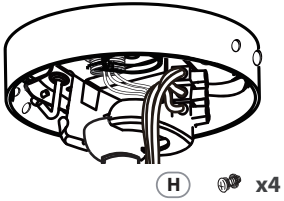
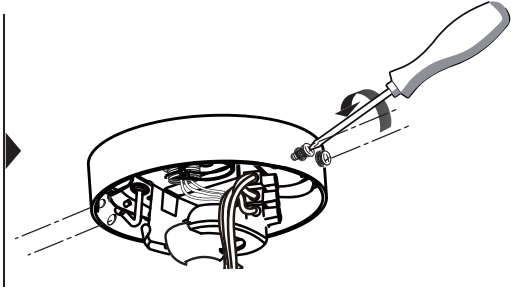
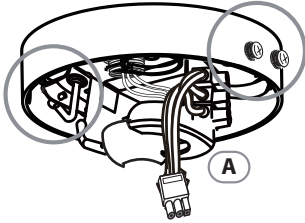

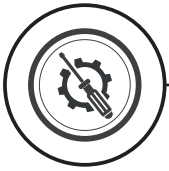

2

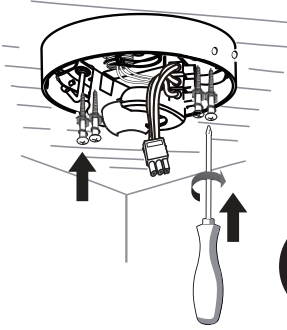

OR

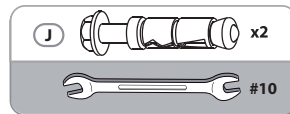
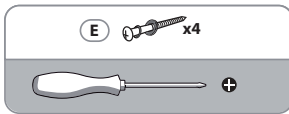
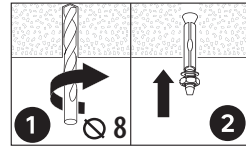
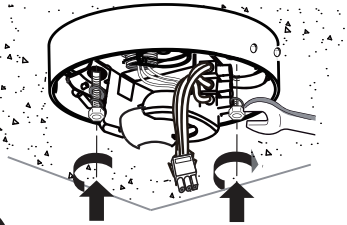

FR - fixé avec une résistance suffisante pour résister à 4 fois le poids du ventilateur de plafond / **ES** - fijado con una resistencia suficiente para soportar 4 veces el peso del ventilador de techo / **PT** - fixado com uma resistência suficiente para suportar 4 vezes o peso do ventilador de teto / **IT** - fissato con una resistenza sufficiente per resistere a 4 volte il peso del ventilatore a soffitto / **GR** - στερεωμένο με επαρκή αντοχή για να αντέξει 4 φορές το βάρος του ανεμιστήρα οροφής / **PL** - przymocowany z wystarczającą wytrzymałością, aby wytrzymać 4 razy ciężar wentylatora sufitowego / **UA** - закріплений з достатньою міцністю, щоб витримати 4-кратний вагу стельового вентилятора / **RO** - fixat cu o rezistență suficientă pentru a rezista la 4 ori greutatea ventilatorului de tavan / **BR** - fixado com uma resistência suficiente para suportar 4 vezes o peso do ventilador de teto / **NL** - bevestigd met voldoende sterkte om 4 keer het gewicht van de plafondventilator te weerstaan / **DE** - mit ausreichender Festigkeit befestigt, um 4-mal das Gewicht des Deckenventilators zu tragen / **EN** - fixed with sufficient strength to withstand 4 times the weight of the ceiling fan

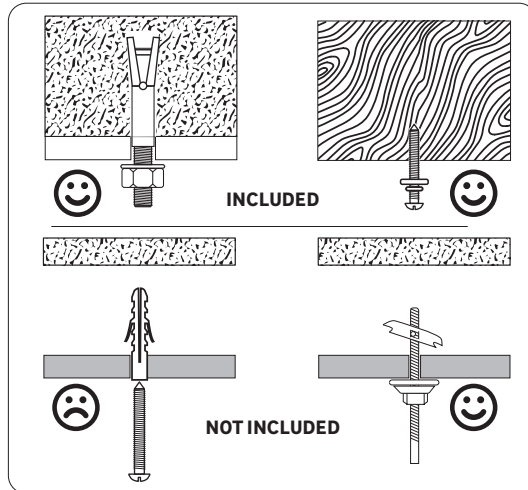
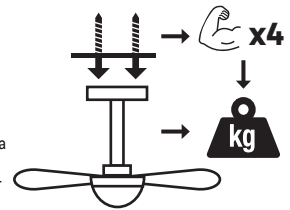

FR - Utiliser des vis et des chevilles adaptées à votre support. / **ES** - Utilice tacos y tornillos adecuados al soporte. / **PT** - Utilize buchas e parafusos adequados ao seu suporte. / **IT** - Utilizzare viti e tasselli adatti per il retro. / **GR** - Χρησιμοποιήστε βίδες και βύσματα που ταίριαζουν στην επιφάνεια στήριξης. / **PL** - Należy użyć śrub i kotków odpowiednich dla podłoża. / **UA** - Використовуйте гвинти та шканти, призначені для задньої поверхні. / **RO** - Utilizați șuruburi și dibluri adecvate pentru suportul dvs. / **BR** - Use parafusos e buchas adequados para seu suporte. / **NL** - Gebruik schroeven en pluggen die geschikt zijn voor uw ondergrond. / **DE** - Verwenden Sie für Ihre Unterlage geeignete Schrauben und Dübel. / **EN** - Use screws and dowels suited to your backing.

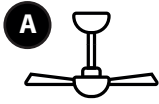

3

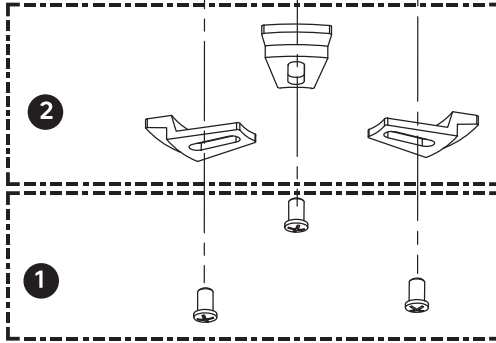
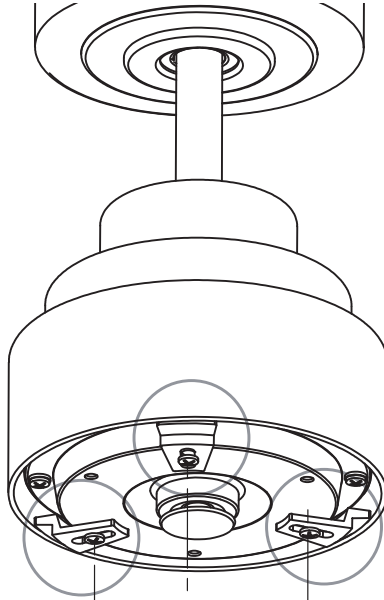

3





4

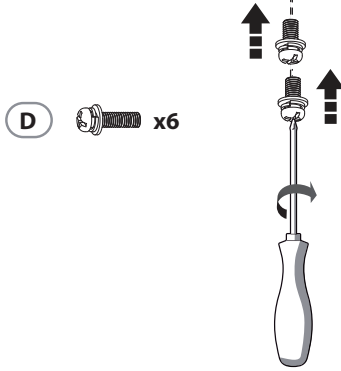
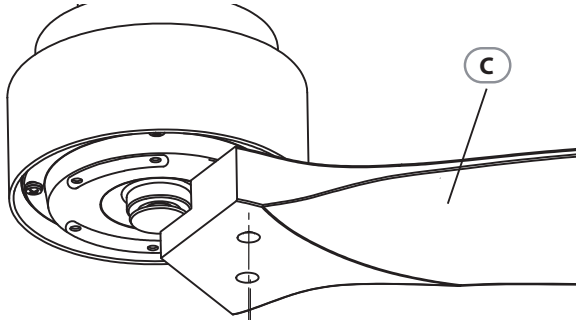

D x6

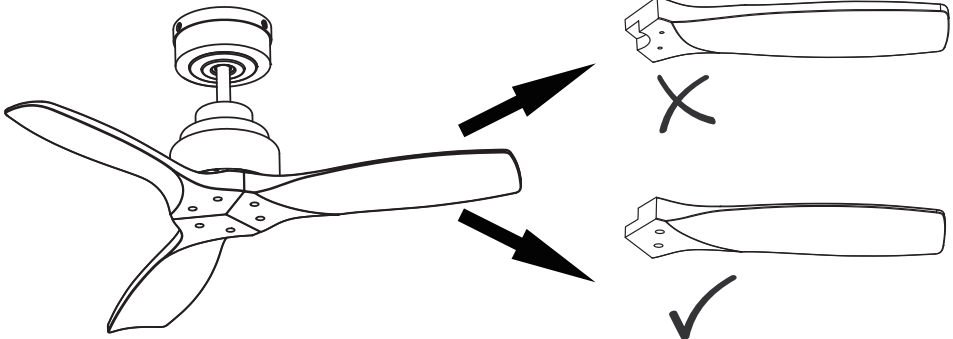
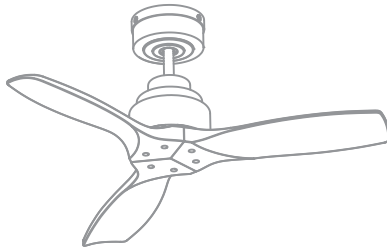



5

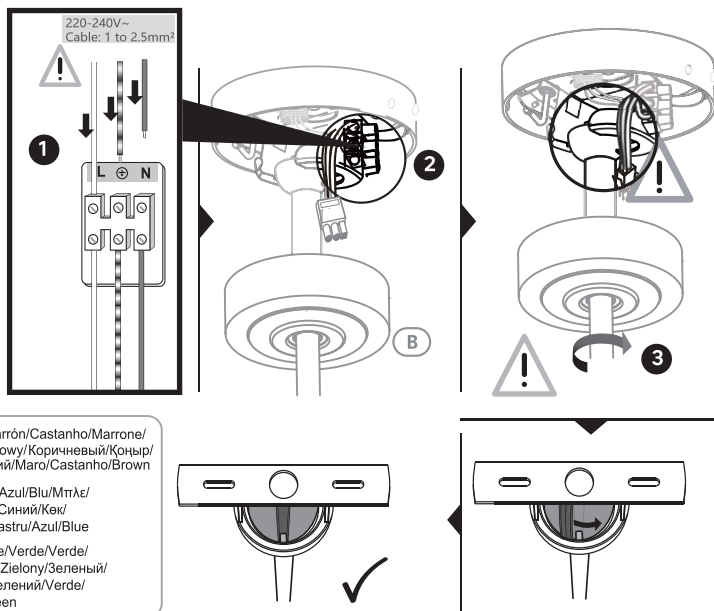

6

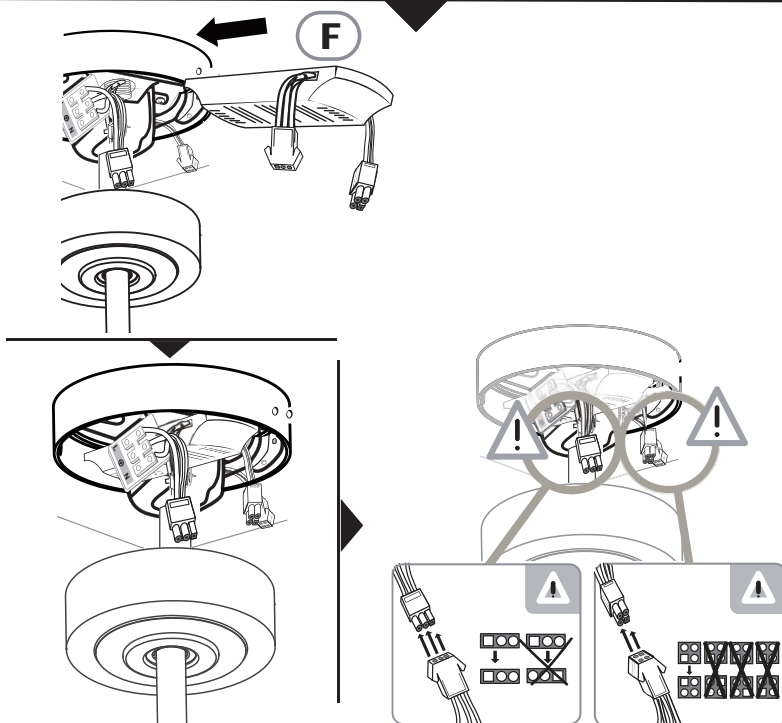



7

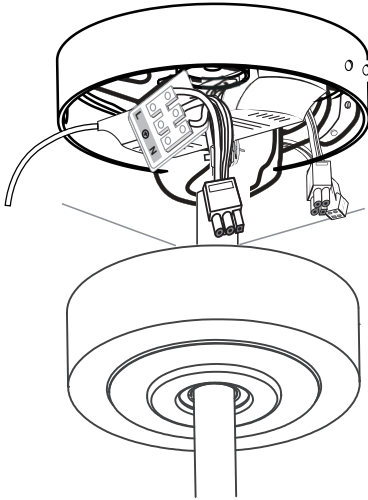

X



✓

8

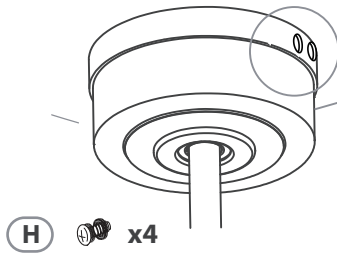

(H)  x4

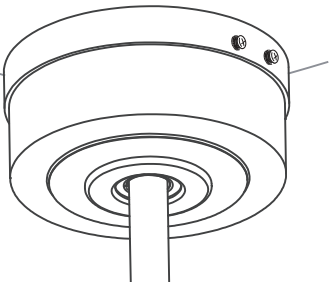
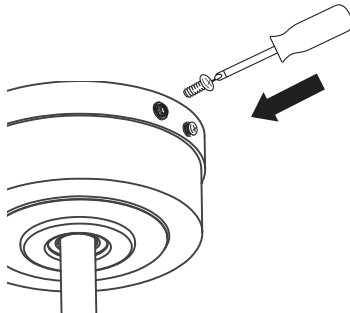
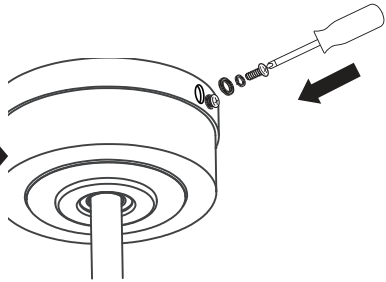



B

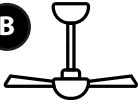

9

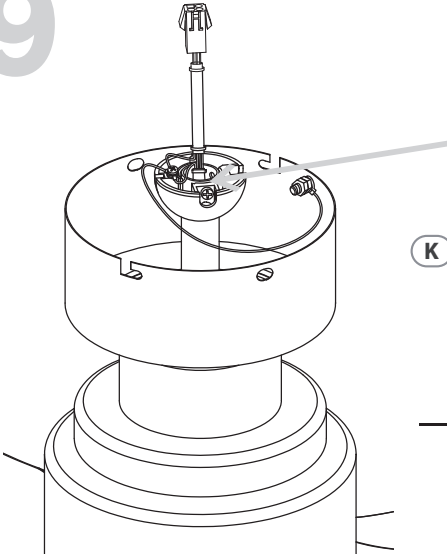

K

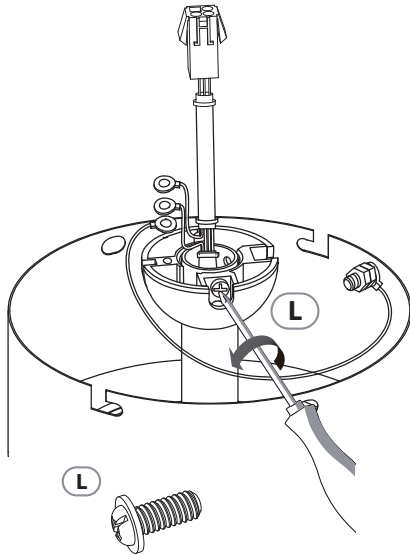
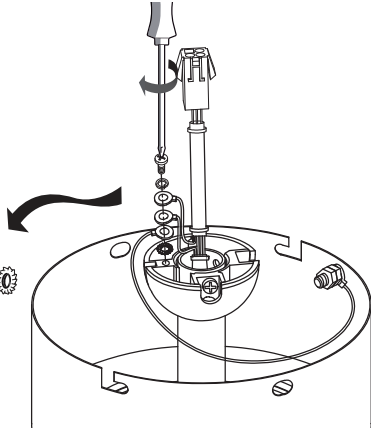

L

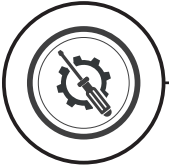

10



1

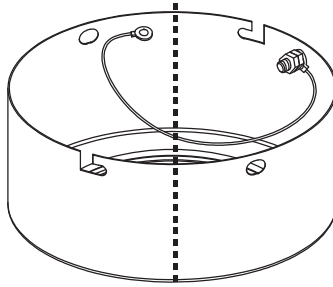

2



3

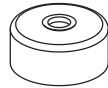
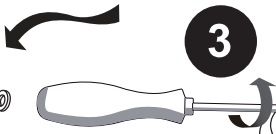

4

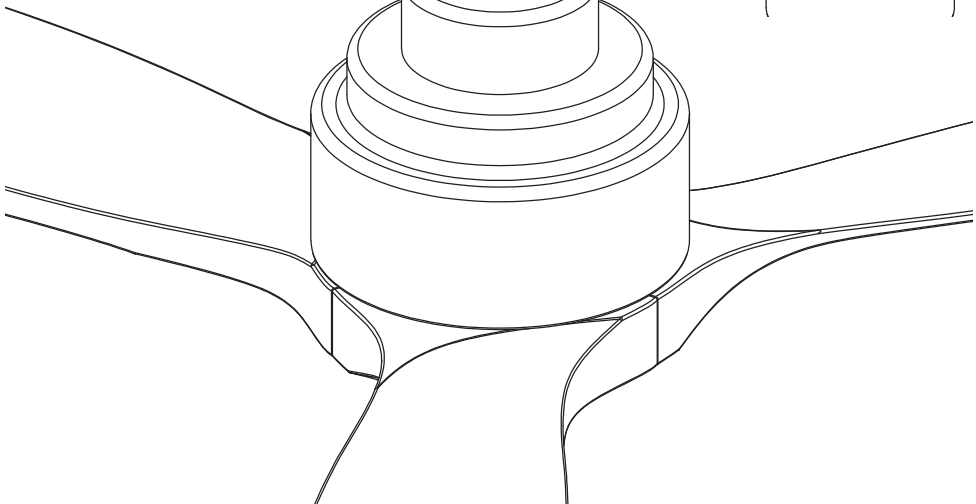
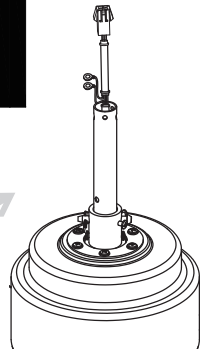



11

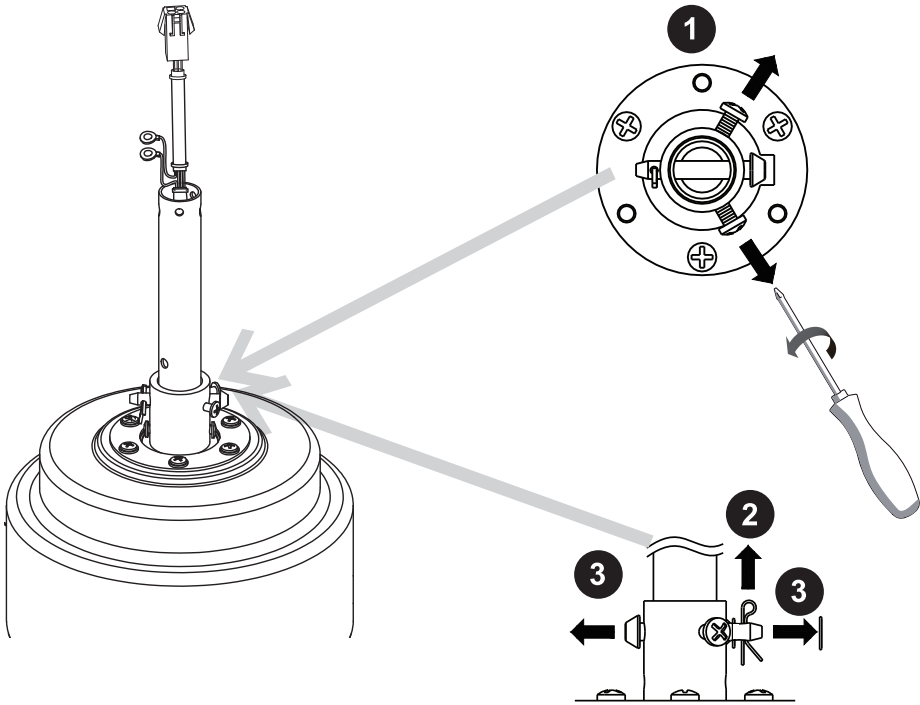

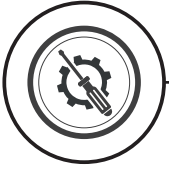

12

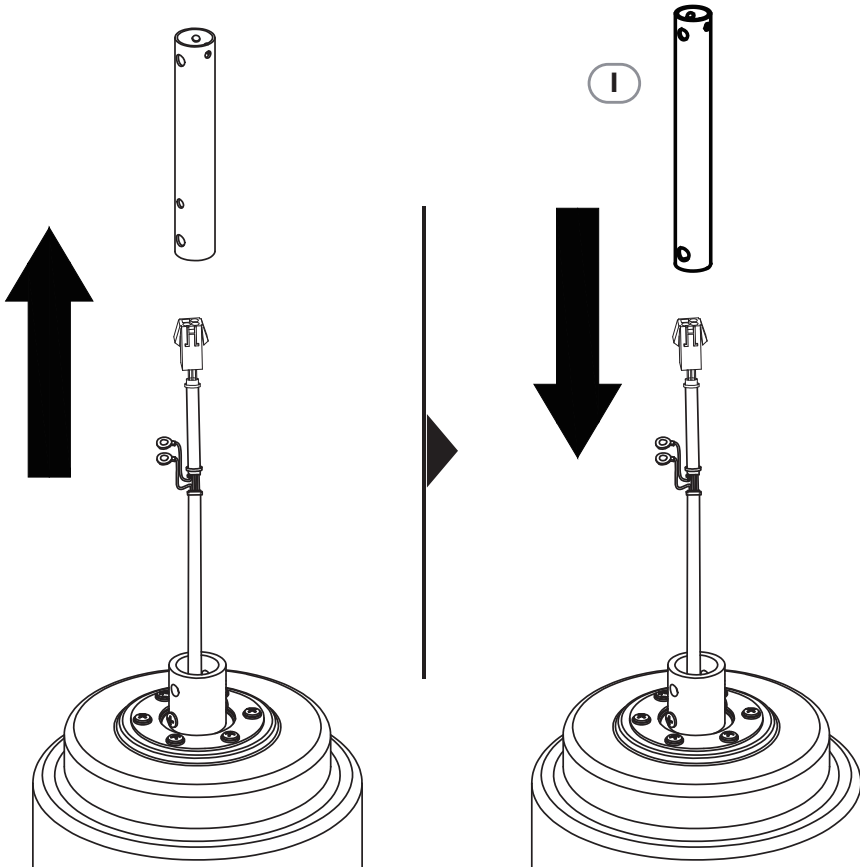

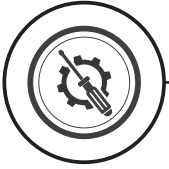

13

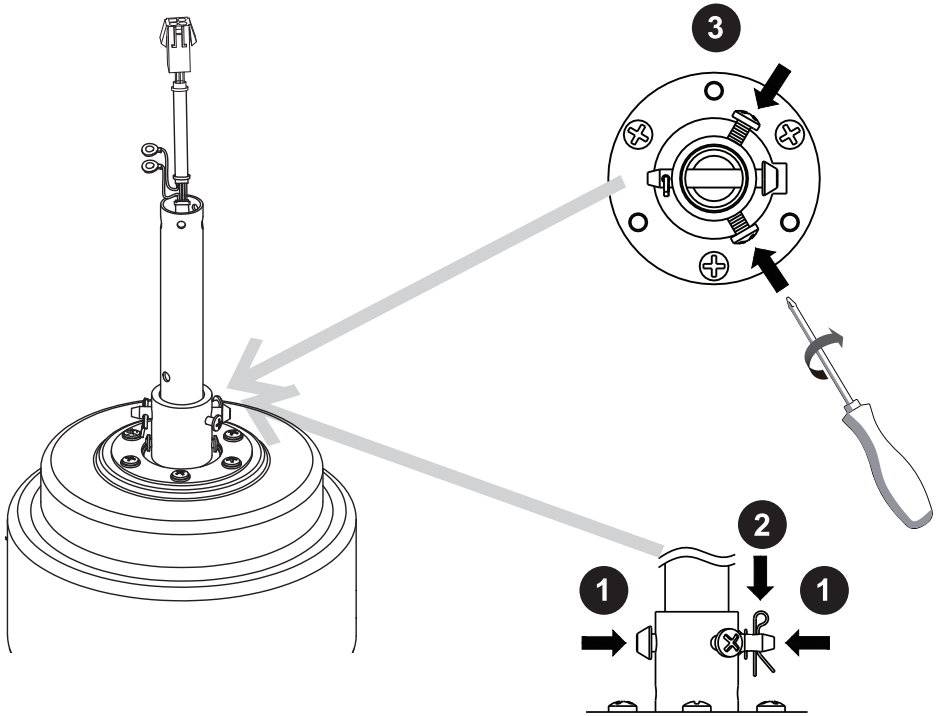

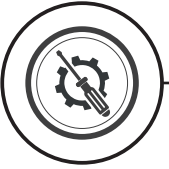

14

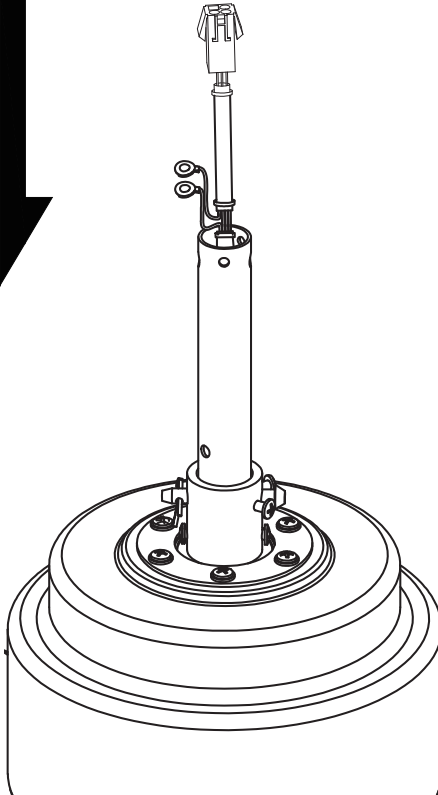
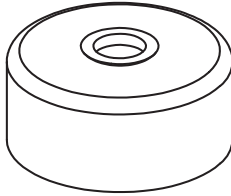



15

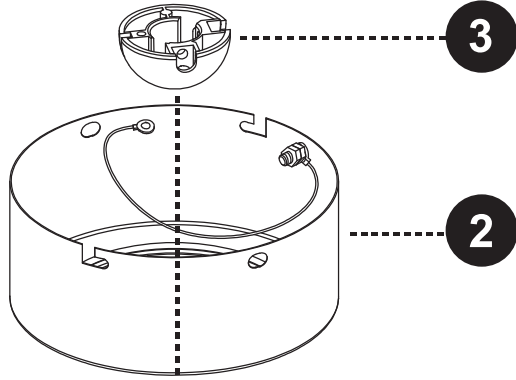

1

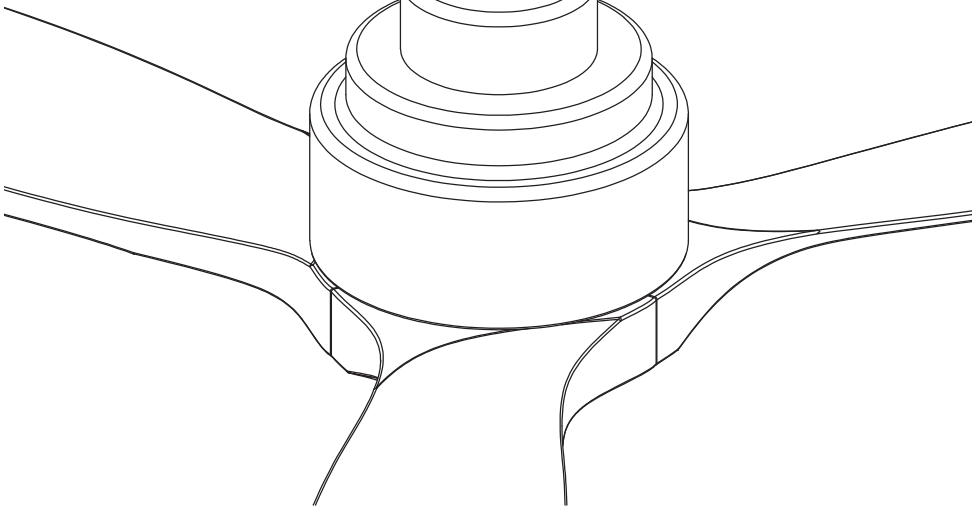



16

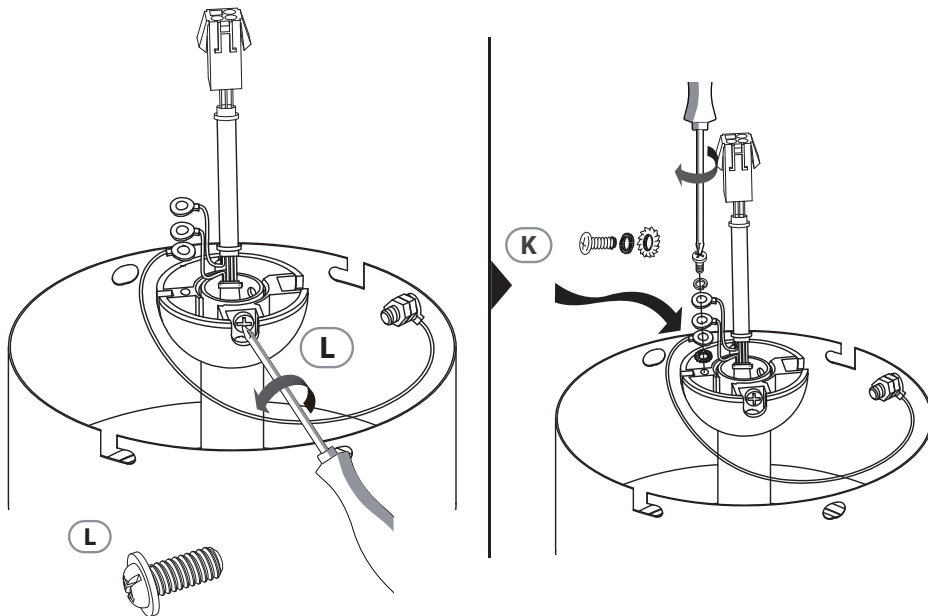

.....

*FR: voir page 9 - 12, étapes 3 - 8 / ES: ver página 9 - 12, pasos 3 - 8
PT: ver página 9 - 12, etapas 3 - 8 / IT: vedere pagina 9 - 12, passaggi 3 - 8
EL: δείτε σελίδα 9 - 12, βήματα 3 - 8 / PL: zobacz stronę 9 - 12, kroki 3 - 8
UA: див. стор. 9 - 12, кроки 3 - 8 / RO: vezi pagina 9 - 12, pași 3 - 8
BR: ver página 9 - 12, etapas 3 - 8 / NL: zie pagina 9 - 12, stappen 3 - 8
DE: siehe Seite 9 - 12, Schritte 3 - 8 / EN: see page 9 - 12, steps 3 - 8



17

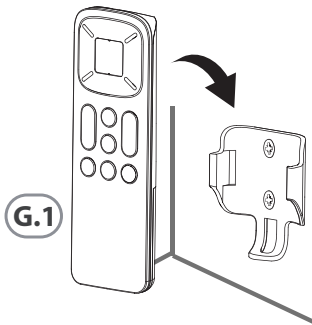
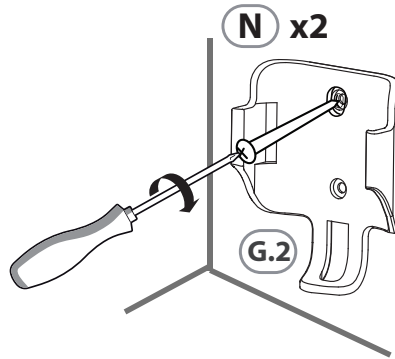
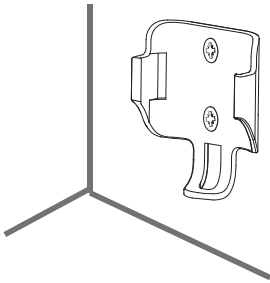
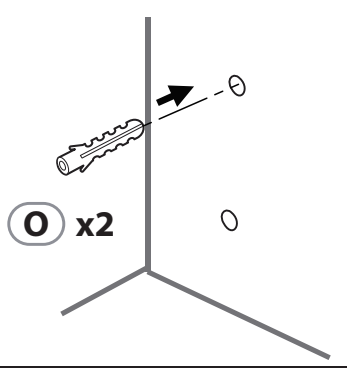
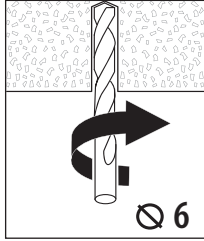

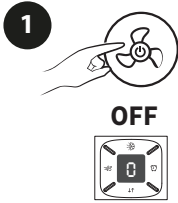

Vitesse/Velocidad/Velocidade /Velocità/Ταχύτητα/Прędkość/Швидкість/Vitezā/Snelheid/ Geschwindigkeit/Speed

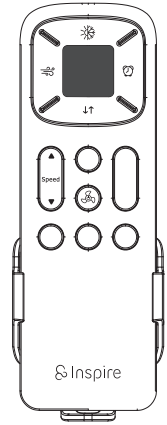
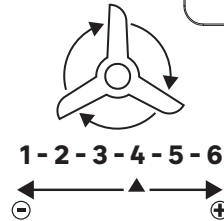
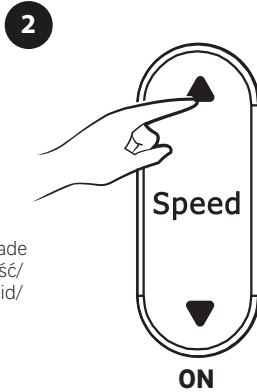

variation de la vitesse / variación de la velocidad / variação da velocidade / variazione della velocità / μεταβολή της ταχύτητας / zmiana prędkości / varіація швидкості / variația vitezei / variação da velocidade / snelheidsvariatie / Geschwindigkeitsvariation / speed variation

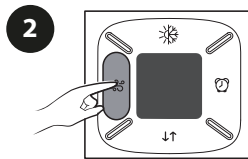

Mode brise / Modo brisa / Modo brisa / Modalità brezza / λειτουργία αεράκι / Tryb bryza / Режим бризу / Modul brizā / Modo brisa / Briesmodus / Brisenmodus / Breeze mode

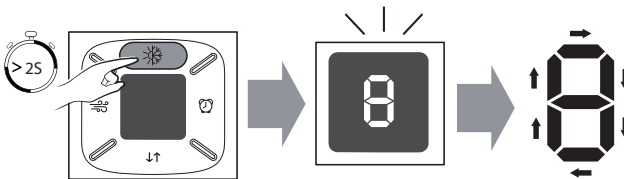
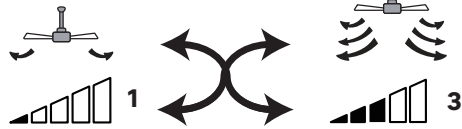

Été/Hiver- Verano/Invierno - Verão/Inverno - Estate/Inverno - Καλοκαίρι/Χειμώνας - Lato/Zima - Літо/Зима - Ará/Iarnā - Zomer/Winter - Sommer/Winter - Summer/Winter

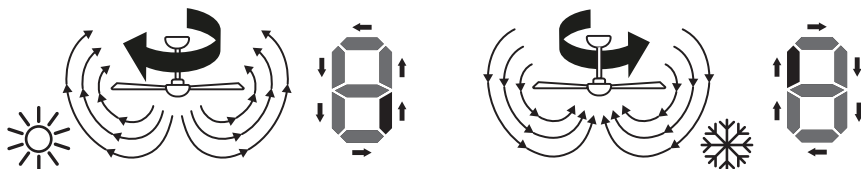

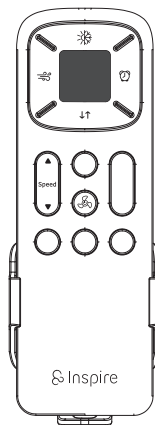
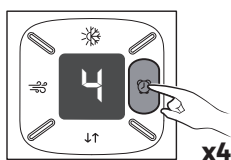
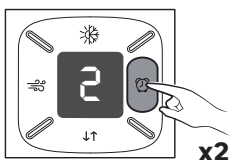
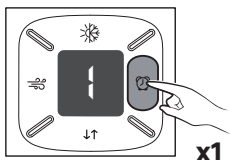

Minuterie/Temporizador/
Χρονοδιακόπτης/Minutnik/
Таймер/Cronometru/Timer

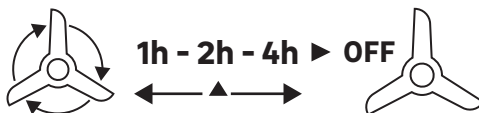



Pair your remote control if the communication with the ceiling fan is not working*

FR: Apparez votre télécommande si la communication avec le ventilateur de plafond ne se fait pas. ES: Empareje su control remoto si la comunicación con el ventilador de techo no se realiza. PT: Emparelhe o seu controle remoto se a comunicação com o ventilador de teto não estiver funcionando. IT: Accoppia il tuo telecomando se la comunicazione con il ventilatore a soffitto non funziona. EL: Συνδέστε το τηλεχειριστήριο σας εάν η επικοινωνία με τον ανεμιστήρα οροφής δεν πραγματοποιείται. PL: Sparuj swój pilot, jeśli nie ma komunikacji z wentylatorem sufitowym. UA: Спаруйте ваш пульт, якщо з'єднання з вентилятором на стелі не відбувається. RO: Asociați telecomanda dacă nu se realizează comunicarea cu ventilatorul de tavan. BR: Emparelhe o seu controle remoto se a comunicação com o ventilador de teto não estiver funcionando. NL: Koppel uw afstandsbediening als de communicatie met de plafondventilator niet werkt. DE: Koppeln Sie Ihre Fernbedienung, wenn die Kommunikation mit dem Deckenventilator nicht funktioniert.

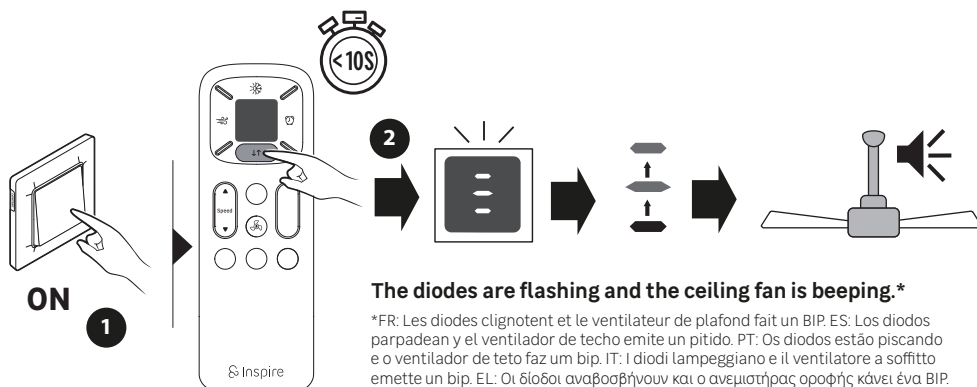

The diodes are flashing and the ceiling fan is beeping.*

*FR: Les diodes clignotent et le ventilateur de plafond fait un BIP. ES: Los diodos parpadean y el ventilador de techo emite un pitido. PT: Os diodos estão piscando e o ventilador de teto faz um bip. IT: I diodi lampeggiano e il ventilatore a soffitto emette un bip. EL: Οι διόδοι αναβοσβήνουν και ο ανεμιστήρας οροφής κάνει ένα BIP. PL: Dioda miga, a wentylator sufitowy wydaje dźwięk. UA: Діоди блимають, а стельовий вентилятор видає звуковий сигнал. RO: Diodele clipește și ventilatorul de tavan face un BIP. BR: Os diodos estão piscando e o ventilador de teto faz um bip. NL: De diodes knipperen en de plafondventilator piept. DE: Die Dioden blinken und der Deckenventilator piept.

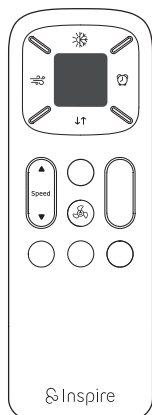

3

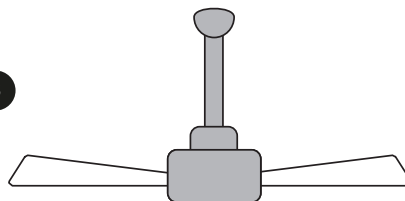

FR - Adeo Services déclare que l'équipement radioélectrique portant la référence mentionnée en première page de ce document, est conforme à la directive 2014/53/UE. Le texte complet de la déclaration UE de conformité est disponible à l'adresse internet suivante: www.product-regulatory.adeoservices.com

ES - Adeo Services declara que el equipo de radio que lleva la referencia mencionada en la primera página de este documento, es conforme con la Directiva 2014/53/UE. El texto completo de la declaración de conformidad de la UE está disponible en la siguiente dirección web: www.product-regulatory.adeoservices.com.

PT - Adeo Services declara que o equipamento de rádio com a referência mencionada na primeira página deste documento está em conformidade com a Diretiva 2014/53/UE. O texto completo da Declaração de Conformidade da UE está disponível no seguinte endereço Web: www.product-regulatory.adeoservices.com

IT - Adeo Services dichiara che l'apparecchiatura radio recante il riferimento indicato nella prima pagina del presente documento è conforme alla Direttiva 2014/53/UE. Il testo completo della Dichiarazione di conformità dell'UE è disponibile al seguente indirizzo web: www.product-regulatory.adeoservices.com

GR - Adeo Services δηλώνει ότι ο ραδιοηλεκτρικός εξοπλισμός που φέρει την αναφερόμενη αναφορά στην πρώτη σελίδα αυτού του εγγράφου, συμμορφώνεται με την Οδηγία 2014/53/ΕΕ. Το πλήρες κείμενο της Δήλωσης Συμμόρφωσης της ΕΕ είναι διαθέσιμο στην ακόλουθη διεύθυνση ιστοσελίδας: www.product-regulatory.adeoservices.com

PL - Adeo Services oświadcza, że urządzenie radiowe opatrzone numerem referencyjnym wymienionym na pierwszej stronie niniejszego dokumentu jest zgodne z dyrektywą 2014/53/UE. Pełny tekst deklaracji zgodności UE jest dostępny pod następującym adresem internetowym: www.product-regulatory.adeoservices.com

UA - Adeo Services заявляє, що радіообладнання, з посиланням на першій сторінці цього документа, відповідає Директиві 2014/53/ЄС. Повний текст Декларації про відповідність ЄС доступний за наступною веб-адресою: www.product-regulatory.adeoservices.com

RO - Adeo Services declară că echipamentul radio care poartă referința menționată pe prima pagină a acestui document, este în conformitate cu Directiva 2014/53/UE. Textul integral al Declarației de Conformitate a UE este disponibil la următoarea adresă web: www.product-regulatory.adeoservices.com

BR - Adeo Services declara que o equipamento de rádio que possui a referência mencionada na primeira página deste documento, está em conformidade com a Diretiva 2014/53/EU. O texto completo da Declaração de Conformidade da UE está disponível no seguinte endereço da web: www.product-regulatory.adeoservices.com

NL - Adeo Services verklaart dat de radioapparatuur met de referentie vermeld op de eerste pagina van dit document, in overeenstemming is met Richtlijn 2014/53/EU. De volledige tekst van de EU-conformiteitsverklaring is beschikbaar op het volgende webadres: www.product-regulatory.adeoservices.com

DE - Adeo Services erklärt, dass das Funksendegerät mit der auf der ersten Seite dieses Dokuments genannten Referenz in Übereinstimmung mit der Richtlinie 2014/53/EU steht. Der vollständige Text der EU-Konformitätserklärung ist unter folgender Webadresse verfügbar: www.product-regulatory.adeoservices.com

EN - Adeo Services declares that the radio equipment bearing the reference mentioned on the first page of this document, is in conformity with Directive 2014/53/EU. The full text of the EU Declaration of Conformity is available at the following web address: www.product-regulatory.adeoservices.com

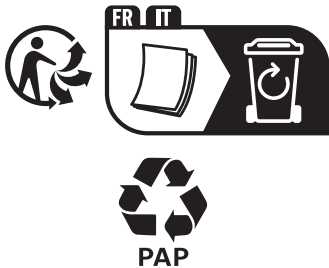

FR Traduction de la version originale du mode d'emploi / ES: Traducción de las Instrucciones originales / PT: Tradução das Instruções Originais / IT: Traduzione delle istruzioni originali / EL: Μετάφραση των πρωτότυπων οδηγιών / PL: Tłumaczenie instrukcji oryginalnej / UA: Переклад оригінальної інструкції / RO: Traducerea instrucțiunilor originale / BR: Tradução das Instruções Originais / DE: Übersetzung der Originalversion der Gebrauchsanweisung / Original Instructions.

Made in China
Країна походження: Китай

EU ADEO Services - 135 Rue Sadi Carnot - CS00001 - 59790 RONCHIN - FRANCE

UA Виробник: ТОВ "Адео Сервісез С.А.", вул. Саді Карно, CS 00001, 59790 Роншен, Франція.
Імпортер: ТОВ "Леруа Мерлен Україна", 04201 Україна, м. Київ, вул. Полярна 17А, +380 44 498 46 00. Імпортер приймає претензії від споживачів щодо товару, а також проводить його ремонт, технічне і гарантійне обслуговування

ZA Imported by Adeo South Africa (PTY) LTD T/A Leroy Merlin, Hosted in Leroy Merlin Fourways Store 35 Roos Street, Witkoppen Ext 97, Sandton, 2191 Johannesburg, Gauteng, South Africa.
Tel: +27 10 493 8000 Email: contact@leroymerlin.co.za.

BR LEROY MERLIN COMPANHIA BRASILEIRA DE BRICOLAGEM CNPJ: 01.438.784/0001-05
Rua Pascoal Pais, nº. 525, 6º andar cj 61 a 64, Vila Cordeiro, São Paulo -SP. CEP: 04581-060
CALM (Central de Atendimento Leroy Merlin) Capitais
4020-5376 Demais Regiões 0800-0205376



Points de collecte sur www.quefairedemesdechets.fr
Privilégiez la réparation ou le don de votre appareil !