

EAN : 3276007887556
Adeo key : 92083399

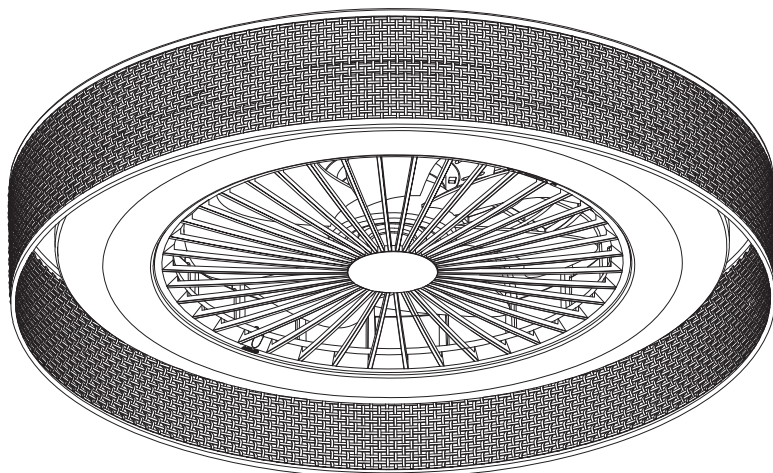

2/2

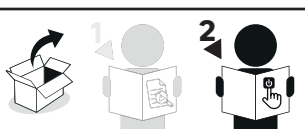

2024-08-V01

FR - Manuel d'Instructions

ES - Manual de Instrucciones

PT - Manual de Instruções

IT - Manuale di Istruzioni

EL - Εγχειρίδιο Οδηγιών

PL - Instrukcja Obsługi

UA - Інструкція з Експлуатації

RO - Manual de Instrucțiuni

BR - Manual de Instrução

NL - Handleiding

DE - Anleitung Handbuch

EN - Instructions Manual

*Année de garantie / años de garantía / Ano de garantia / Anno di garanzia / Έτος εγγύησης / Rok gwarancji / Гарантіяроків / Anul de garanție / Anos de garantia / Garantiejaar / Jahr der Garantie / Year of guarantee

**réparable / reparabile / reparável / riparabile / διορθώσιμος / naprawiany / ремонтний / reparabil / reparaturfähig / reparável / herstelbaar / reparierbar / repairable



FR : assemblage / **ES :** ensamblaje / **PT :** montagem / **IT :** assemblaggio /
EL : συναρμολόγηση / **PL :** montaż / **UA :** збірка / **RO :** asamblare /
BR : montagem / **NL :** samenstelling / **DE :** Montage / **EN :** assembly



FR : Utilisation / **ES :** Uso / **PT :** Utilização / **IT :** Utilizzo
EL : Χρήση / **PL :** Użycie / **UA :** Використання / **RO :** Utilizare /
BR : Utilização / **NL :** Gebruik / **DE :** Verwendung / **EN :** Use



FR : Nettoyage / **ES :** Limpieza / **PT :** Limpeza / **IT :** Pulizia / **EL :**
Καθάρισμα / **PL :** Czyszczenie / **UA :** Чищення / **RO :** Curățare /
BR : Limpeza / **NL :** Schoonmaken / **DE :** Reinigung / **EN :** Cleaning

FR : CARACTÉRISTIQUES TECHNIQUES / **ES :** CARACTERÍSTICAS TÉCNICAS /
PT : CARACTERÍSTICAS TÉCNICAS / **IT :** CARATTERISTICHE TECNICHE / **EL :** ΤΕΧΝΙΚΑ
ΧΑΡΑΚΤΗΡΙΣΤΙΚΑ / **PL :** CECHY TECHNICZNE / **UA :** ΤΕΧΝΙΚΗ ΧΑΡΑΚΤΗΡΙΣΤΙΚΗ /
RO : CARACTERISTICI TEHNICE / **BR :** CARACTERÍSTICAS TÉCNICAS / **NL :** TECHNISCHE
KENMERKEN / **DE :** TECHNISCHE MERKMALE / **EN :** TECHNICAL SPECIFICATIONS

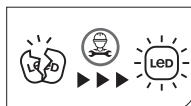
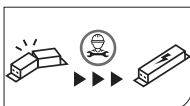
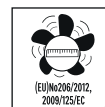
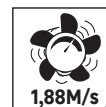
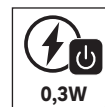
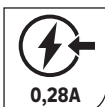
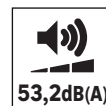
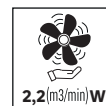
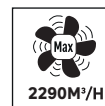
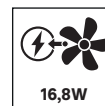
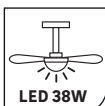
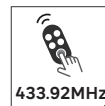
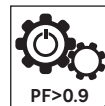
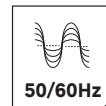
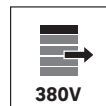
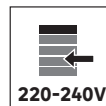
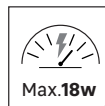
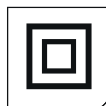

FR - Ce produit contient une source lumineuse de classe d'efficacité énergétique **D** (EU) 2019/2015
ES - Este producto contiene una fuente de luz de clase de eficiencia energética **D** (EU) 2019/2015
PT - Este produto contém uma fonte luminosa de classe de eficiência energética **D** (EU) 2019/2015
IT - Questo prodotto contiene una sorgente luminosa di classe di efficienza energetica **D** (EU) 2019/2015
EL - Αυτό το προϊόν περιέχει μια πηγή φωτός τάξης ενεργειακής απόδοσης **D** (EU) 2019/2015
PL - Ten produkt zawiera źródło światła o klasie efektywności energetycznej **D** (EU) 2019/2015
UA - Цей продукт містить джерело світла класу енергоефективності **D** (EU) 2019/2015
RO - Acest produs conține o sursă de lumină de clasă de eficiență energetică **D** (EU) 2019/2015
BR - Este produto contém uma fonte luminosa de classe de eficiência energética **D** (EU) 2019/2015
NL - Dit product bevat een lichtbron met energie-efficiëntieklasse **D** (EU) 2019/2015
DE - Dieses Produkt enthält eine Lichtquelle der Energieeffizienzklasse **D** (EU) 2019/2015
EN - This product contains a light source of energy efficiency class **D** (EU) 2019/2015



1 2 3 4 5 6



4,4 5,6 7,4 9,8 12,4 16,8

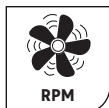

550 649 752 850 949 1050

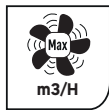

660 1080 1280 1810 2040 2290



2,5 3,2 2,9 3,0 2,7 2,2



36,3 39,6 43,4 46,9 50,2 53,2



A

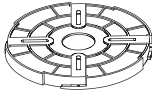

B

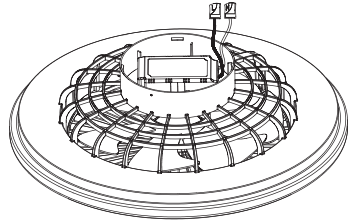

C

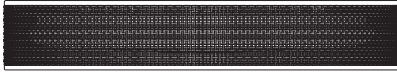

D



E



F



G



H



I

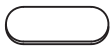

J

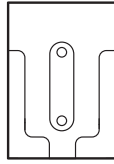

K



L



0 1 2 3 4 5 6 cm

+

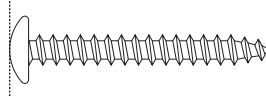

D x2

+

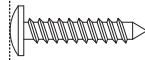

G x2

+



F x1



FR : Scanner ce code QR pour voir la vidéo de montage

ES : Escanear este código QR para ver el video de montaje

PT : Digitalize este código QR para ver o vídeo de montagem

IT : Scannerizza questo codice QR per vedere il video di montaggio

EL : Σαρώστε τον συγκεκριμένο κωδικό QR για να δείτε το βίντεο συναρμολόγησης

PL : Zeskanuj ten kod QR, aby zobaczyć wideo montażowe

UA : Відскануйте цей QR-код, щоб переглянути відео про монтаж

RO : Scanați acest cod QR pentru a viziona videoclipul de montaj

BR : Escanear este código QR para ver o vídeo de montagem

NL : Scan deze QR-code om de montagevideo te bekijken

DE : Scannen Sie diesen QR-Code, um das Montagevideo anzusehen

EN : Scan this QR code to view the assembly video

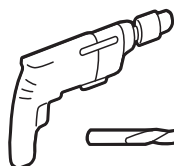
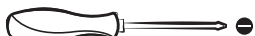

Ø6mm

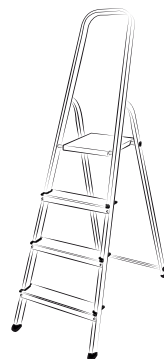
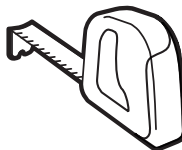

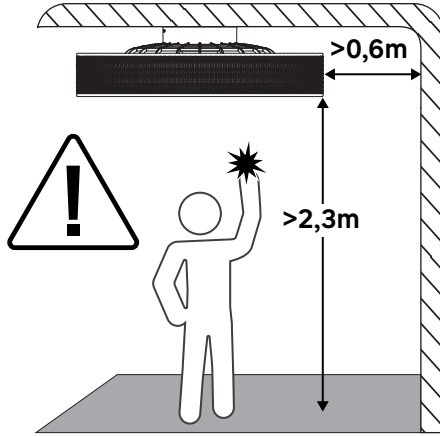
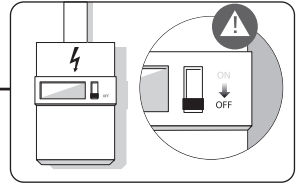
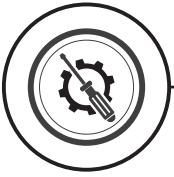

1

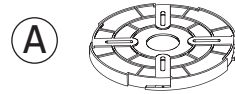
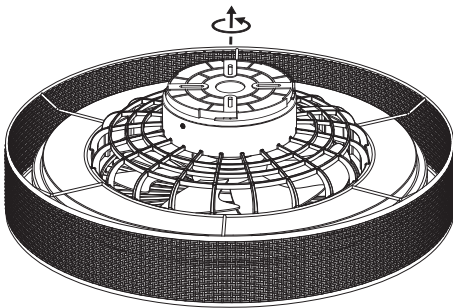

+

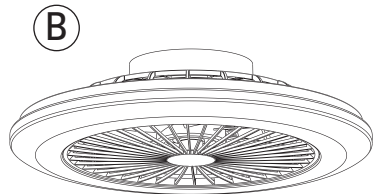

C

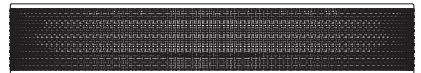

2

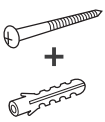
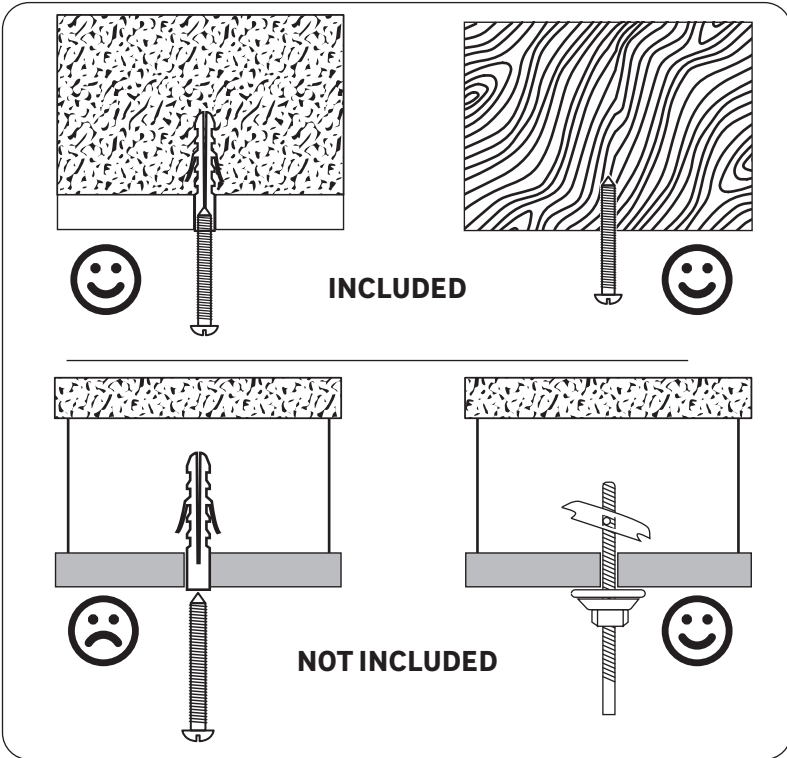
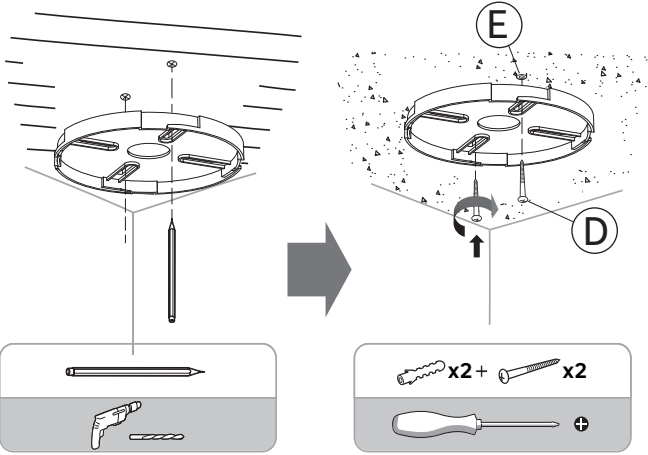

Utiliser des vis et des chevilles adaptées à votre support / Utilice tacos y tornillos adecuados al soporte / Utilize buchas e parafusos adequados ao seu suporte / Utilizzare viti e tasselli adatti per il retro / Χρησιμοποιήστε βίδες και βύσματα που ταιριάζουν στην επιφάνεια στήριξης. / Należy użyć śrub i kołków odpowiednich dla podłoża / Використовуйте гвинти та шканти, призначені для задньої поверхні. / Utilizați șuruburi și dibluri adecvate pentru suportul dvs. / Use parafusos e buchas adequados para seu suporte / Verwenden Sie für Ihre Unterlage geeignete Schrauben und Dübel / Use screws and dowels suited to your backing

3

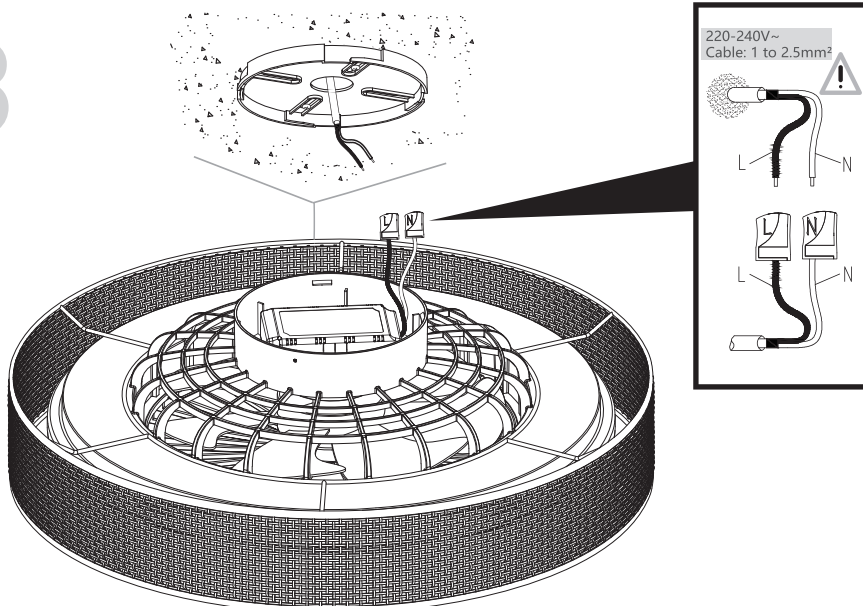

N =Bleu/Azul/Azul/Blu/Мпале/Niebieski/ Синій/Albastru/Azul/Blau/Blue

L =Marron/Ma rrón/Castanho/Ma rrone/Кафэ/Brązowy/
Кори чневий/Ma ro/Ma rrom/B raun/Brown

4

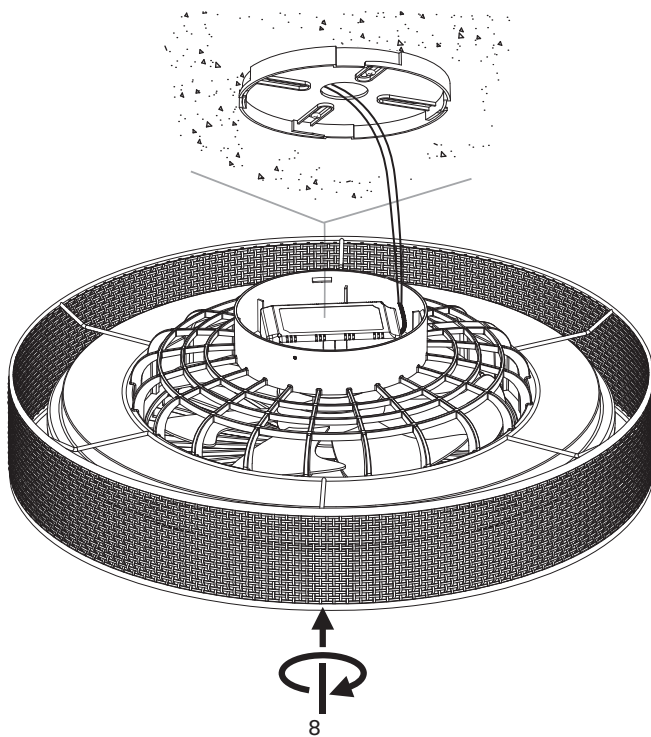

5

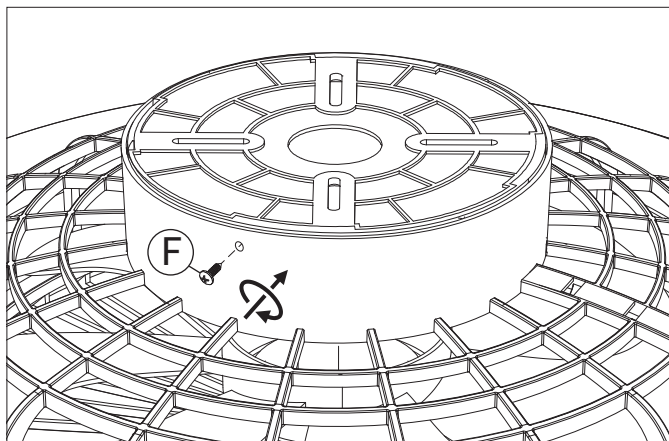

6

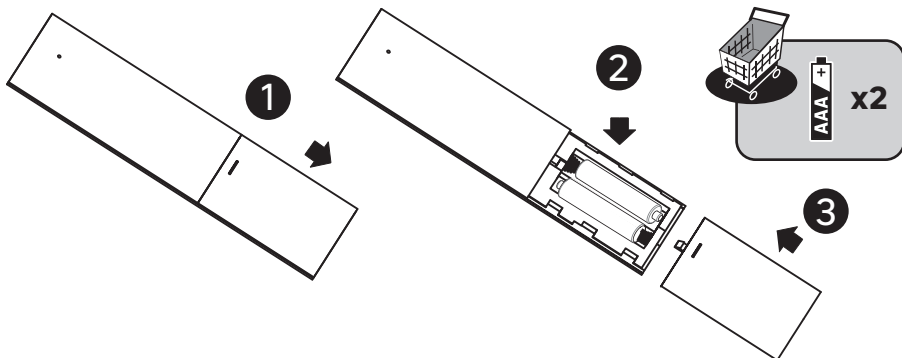
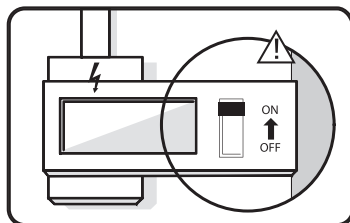

7

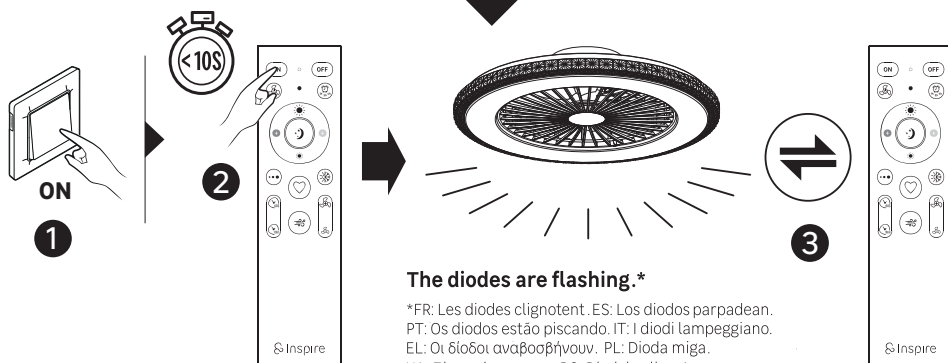
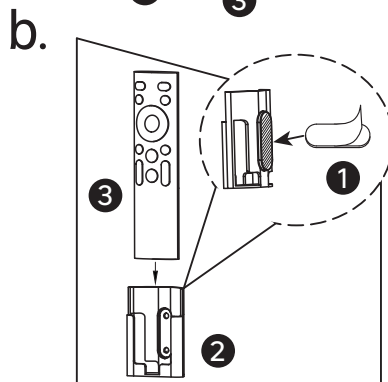
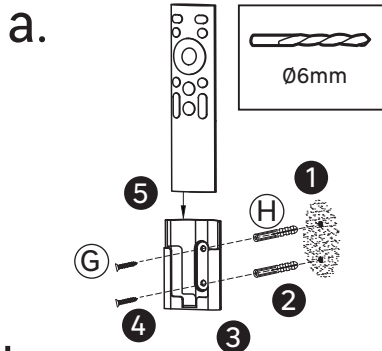
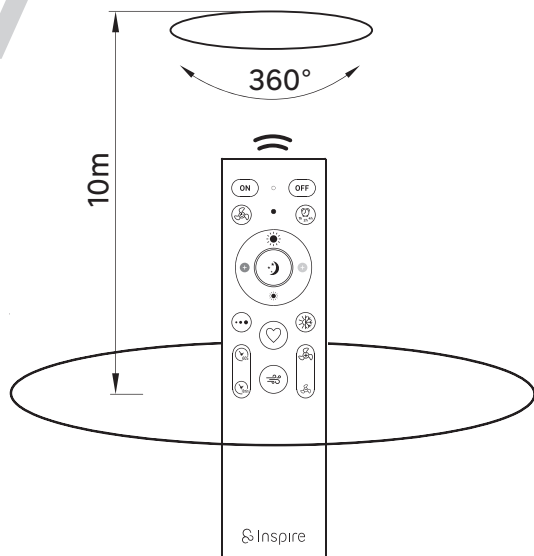

Pair your remote control if the communication with the ceiling fan is not working*

FR: Appareyez votre télécommande si la communication avec le ventilateur de plafond ne se fait pas. ES: Empareje su control remoto si la comunicación con el ventilador de techo no se realiza. PT: Emparelhe o seu controle remoto se a comunicação com o ventilador de teto não estiver funcionando. IT: Accoppia il tuo telecomando se la comunicazione con il ventilatore a soffitto non funziona. EL: Συνδέστε το τηλεχειριστήριό σας εάν η επικοινωνία με τον ανεμιστήρα οροφής δεν πραγματοποιείται. PL: Sparuj swój pilot, jeśli nie ma komunikacji z wentylatorem sufitowym. UA: Спаруйте ваш пульт, якщо з'єднання з вентилятором на стелі не відбувається. RO: Asociați telecomanda dacă nu se realizează comunicarea cu ventilatorul de tavan. BR: Emparelhe o seu controle remoto se a comunicação com o ventilador de teto não estiver funcionando. NL: Koppel uw afstandsbediening als de communicatie met de plafondventilator niet werkt. DE: Koppeln Sie Ihre Fernbedienung, wenn die Kommunikation mit dem Deckenventilator nicht funktioniert.

8

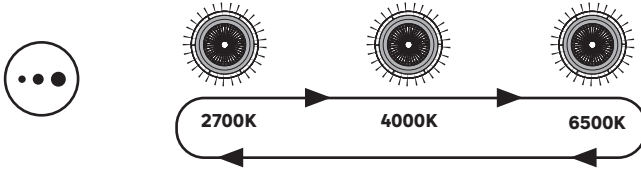
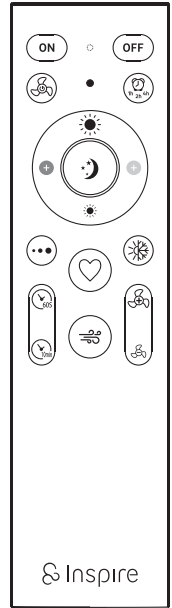
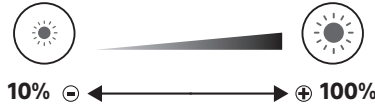
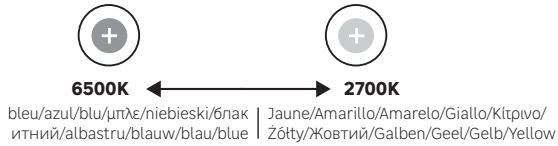
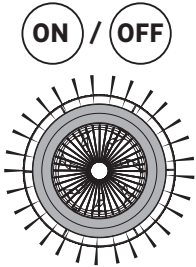

mémoriser le dernier réglage / recordar la última configuración / memorizar a última configuração / memorizzare l'ultima impostazione / αποθηκεύστε την τελευταία ρύθμιση / zapamiętać ostatnie ustawienie / запам'ятати останнє налаштування / memorati ultima setare / memorizar a última configuração / de laatste instelling onthouden / die letzte Einstellung speichern / remember the last setting

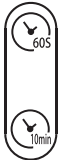

Minuterie/Temporizador/
Χρονοδιακόπτης/Minutnik/
Таймер/Cronometru/Timer

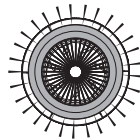

60S

10min



Vitesse/Velocidad/Velocidade/Velocità
/Ταχύτητα/Прędkość/Швидкість/Vitezä
/Snelheid/Geschwindigkeit/Speed

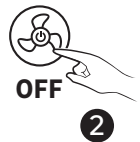
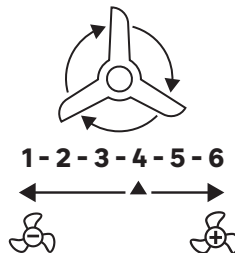



Mode brise / Modo brisa / Modo brisa / Modalità brezza /
 Λειτουργία αεράκι / Tryb bryza / Режим бризу / Modul brizá /
 Modo brisa / Briesmodus / Brisenmodus / Breeze mode

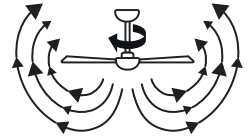

variation de la vitesse / variación de la velocidad / variação da velocidade / variazione della velocità / μεταβολή της ταχύτητας / zmiana prędkości /
 variação швидкості / variația vitezei / variação da velocidade / snelheidsvariatie / Geschwindigkeitsvariation / speed variation



Été/Hiver- Verano/Invierno -
 Verão/Inverno - Estate/Inverno -
 Καλοκαίρι/Χειμώνας - Lato/Zima -
 Літо/Зима - Ará/larná - Zomer/Winter -
 Sommer/Winter - Summer/Winter

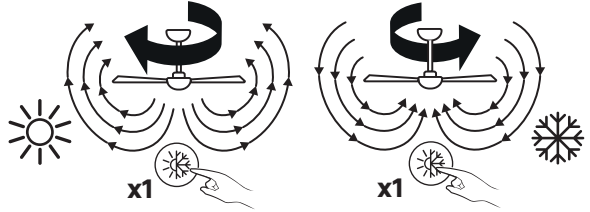

Minuterie/Temporizador/
 Χρονοδιακόπτης/Minutnik/
 Таймер/Сronometru/Timer

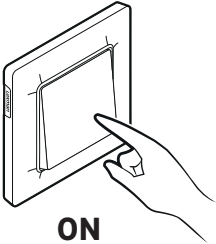
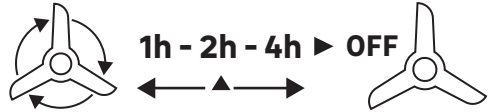

Avec le Ventilateur/Con el Ventilador/Com o Ventilador/Con il Ventilatore/Με τον Ανεμιστήρα/Z Wentylatorem/
 з Вентилятором/Cu Ventilatorul/Met de Ventilator/Mit dem Ventilator/**With the Ceiling Fan**

2700K

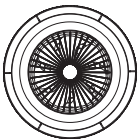

4000K

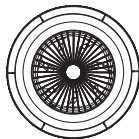

6500K

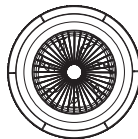

6500K+

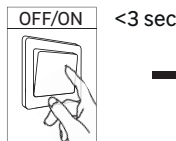
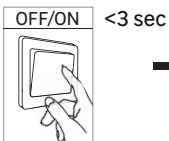
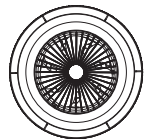

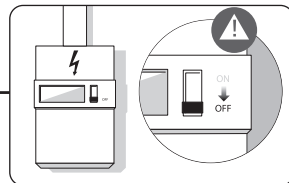

9

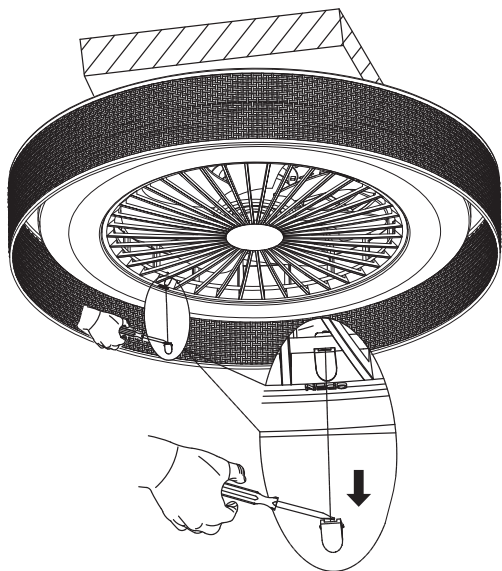

10

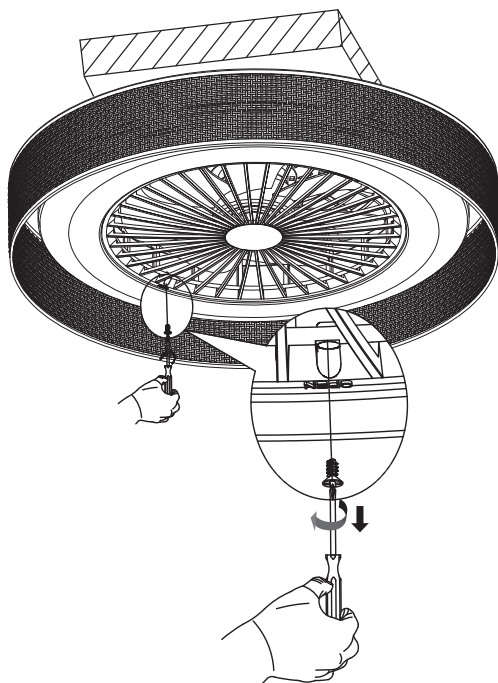

11

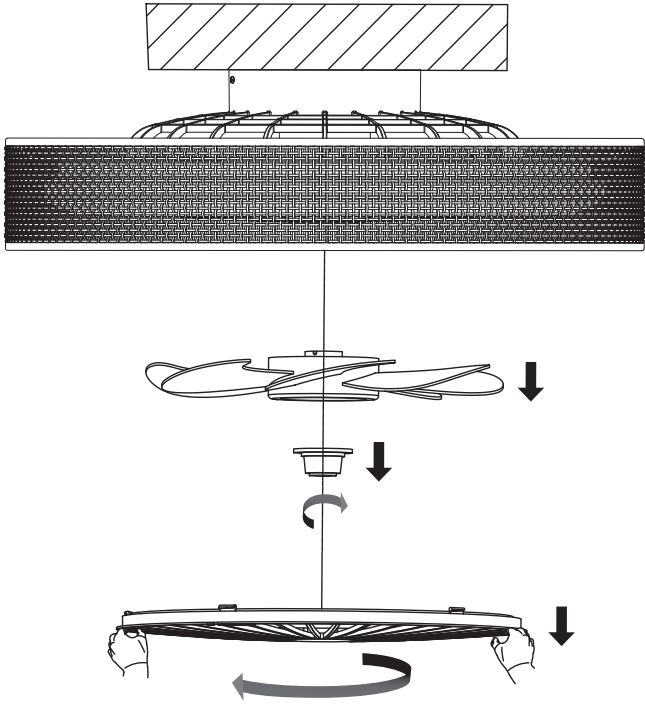

FR – Adeo Services déclare que l'équipement radioélectrique portant la référence mentionnée en première page de ce document, est conforme à la directive 2014/53/UE. Le texte complet de la déclaration UE de conformité est disponible à l'adresse internet suivante: www.product-regulatory.adeoservices.com

ES – Adeo Services declara que el equipo de radio que lleva la referencia mencionada en la primera página de este documento, es conforme con la Directiva 2014/53/UE. El texto completo de la declaración de conformidad de la UE está disponible en la siguiente dirección web: www.product-regulatory.adeoservices.com.

PT – Adeo Services declara que o equipamento de rádio com a referência mencionada na primeira página deste documento está em conformidade com a Diretiva 2014/53/UE. O texto completo da Declaração de Conformidade da UE está disponível no seguinte endereço Web: www.product-regulatory.adeoservices.com

IT – Adeo Services dichiara che l'apparecchiatura radio recante il riferimento indicato nella prima pagina del presente documento è conforme alla Direttiva 2014/53/UE. Il testo completo della Dichiarazione di conformità dell'UE è disponibile al seguente indirizzo web: www.product-regulatory.adeoservices.com

GR – Adeo Services δηλώνει ότι ο ραδιοηλεκτρικός εξοπλισμός που φέρει την αναφερόμενη αναφορά στην πρώτη σελίδα αυτού του εγγράφου, συμμορφώνεται με την Οδηγία 2014/53/ΕΕ. Το πλήρες κείμενο της Δήλωσης Συμμόρφωσης της ΕΕ είναι διαθέσιμο στη ακόλουθη διεύθυνση ιστοσελίδας: www.product-regulatory.adeoservices.com

PL – Adeo Services oświadcza, że urządzenie radiowe opatrzone numerem referencyjnym wymienionym na pierwszej stronie niniejszego dokumentu jest zgodne z dyrektywą 2014/53/UE. Pełny tekst deklaracji zgodności UE jest dostępny pod następującym adresem internetowym: www.product-regulatory.adeoservices.com

UA – Adeo Services заявляє, що радіообладнання, з посиланням на першій сторінці цього документа, відповідає Директиві 2014/53/ЄС. Повний текст Декларації про відповідність ЄС доступний за наступною веб-адресою: www.product-regulatory.adeoservices.com

RO – Adeo Services declară că echipamentul radio care poartă referința menționată pe prima pagină a acestui document, este în conformitate cu Directiva 2014/53/UE. Textul integral al Declarației de Conformitate a UE este disponibil la următoarea adresă web: www.product-regulatory.adeoservices.com

BR – A Adeo Services declara que o equipamento de rádio que possui a referência mencionada na primeira página deste documento, está em conformidade com a Diretiva 2014/53/EU. O texto completo da Declaração de Conformidade da UE está disponível no seguinte endereço da web: www.product-regulatory.adeoservices.com

NL – Adeo Services verklaart dat de radioapparatuur met de referentie vermeld op de eerste pagina van dit document, in overeenstemming is met Richtlijn 2014/53/EU. De volledige tekst van de EU-conformiteitsverklaring is beschikbaar op het volgende webadres: www.product-regulatory.adeoservices.com

DE – Adeo Services erklärt, dass das Funksendegerät mit der auf der ersten Seite dieses Dokuments genannten Referenz in Übereinstimmung mit der Richtlinie 2014/53/EU steht. Der vollständige Text der EU-Konformitätserklärung ist unter folgender Webadresse verfügbar: www.product-regulatory.adeoservices.com

EN – Adeo Services declares that the radio equipment bearing the reference mentioned on the first page of this document, is in conformity with Directive 2014/53/EU. The full text of the EU Declaration of Conformity is available at the following web address: www.product-regulatory.adeoservices.com



Made in China
Країна походження: Китай

EU - ADEO Services - 135 Rue Sadi Carnot - CS00001 - 59790 RONCHIN - FRANCE
www.product-regulatory.adeoservices.com

UA Виробник: ТОВ "Адео Сервісез С.А.", вул. Саді Карно, CS 00001, 59790 Роншен, Франція.
Імпортер, суб'єкт господарювання, що відповідає за виконання гарантійних зобов'язань: ТОВ "Леруа Мерлен Україна", 04201 Україна, м.Київ, вул. Полярна 17А, +380 44 498 46 00.

BR LEROY MERLIN COMPANHIA BRASILEIRA DE BRICOLAGEM CNPJ: 01.438.784/0001-05
Rua Pascoal Pais, nº. 525, 6º andar cj 61 a 64, Vila Cordeiro, São Paulo -SP. CEP: 04581-060
CALM (Central de Atendimento Leroy Merlin)
Capitais 4020-5376 Demais Regiões
0800-0205376

ZA Imported by Adeo South Africa (PTY) LTD T/A Leroy Merlin,
Hosted in Leroy Merlin Fourways Store 35 Roos Street, Witkoppen Ext 97, Sandton, 2191 Johannesburg, Gauteng, South Africa.
Tel: +27 10 493 8000 Email: contact@leroymerlin.co.za.



Points de collecte sur www.quefairedemesdechets.fr
Privilégiez la réparation ou le don de votre appareil !