

- FR** Nous vous remercions d'avoir acheté ce produit. Nous vous conseillons de lire attentivement la notice d'installation, d'utilisation et d'entretien. Nous avons conçu ce produit pour vous apporter entière satisfaction. Si vous avez besoin d'aide l'équipe de votre magasin est à votre disposition pour vous accompagner.
- ES** Le agradecemos haber comprado este producto. Le recomendamos leer atentamente el manual de instalación, uso y mantenimiento. Este producto ha sido diseñado para proporcionarle plena satisfacción. Si necesita alguna ayuda, el personal de la tienda estará a su disposición para guiarle.
- PT** Agradecemos a sua preferência por este produto . Aconselhamo-lo a ler o manual de instalação, utilização e manutenção com atenção. Criámos este produto para sua completa satisfação. Se precisar de ajuda, a equipa da sua loja está à sua disposição para o acompanhar.
- IT** Grazie per aver acquistato questo prodotto. Vi raccomandiamo di leggere attentamente il manuale di installazione, utilizzo e manutenzione. Questo prodotto è stato progettato per offrirvi la massima soddisfazione. Per ricevere assistenza, il personale del punto vendita è a vostra disposizione.
- EL** Ευχαριστούμε για την αγορά σας αυτού του προϊόντος. Σας συμβουλεύουμε να διαβάσετε προσεκτικά τις οδηγίες εγκατάστασης, χρήσης και συντήρησης. Σχεδιάσαμε αυτό το προϊόν για να σας προσφέρει πλήρη ικανοποίηση. Αν χρειάζεστε βοήθεια, η ομάδα του καταστήματος από το οποίο αγοράσατε το προϊόν είναι στη διάθεσή σας.
- PL** Dziękujemy za zakup produktu firmy. Zalecamy, aby uważanie przeczytać instrukcję instalacji, użytkowania i konserwacji. Ten produkt marki zaprojektowaliśmy, aby spełnić wszystkie państwa oczekiwania. W razie potrzeby pracownicy sklepu służą Państwu pomocą i są do Państwa dyspozycji.
- UA** Дякуємо за придбання цього продукту. Ми рекомендуємо вам уважно прочитати інструкції зі встановлення, використання та обслуговування. Ми розробили цей продукт, щоб забезпечити ваше повне задоволення. Якщо вам потрібна допомога, команда вашого продавця завжди готова допомогти вам.
- RO** Vă mulțumim pentru achiziționarea acestui produs . Vă sfatuim să citiți cu atenție instrucțiunile de instalare, de utilizare și de întreținere. Am conceput acest produs pentru a vă furniza satisfacție totală. Dacă aveți nevoie de ajutor, echipa magazinului de cumpărare este la dispoziția dumneavoastră pentru a vă asista.
- BR** Obrigado por ter adquirido um produto . Nós aconselhamos a ler atentamente o manual de instalação, uso e manutenção. Concebemos um produto para proporcionar total satisfação. Caso precise de ajuda, a equipe da sua loja estará à disposição para te acompanhar.
- EN** Thank you for purchasing this product. We recommend that you read the installation, user and maintenance instructions carefully. We have designed this product to ensure your complete satisfaction. If you require assistance, the team at your retailer is on hand to help you.

- FR** AVERTISSEMENT : Pour éviter tout risque de basculement, ce meuble/objet doit être solidement fixé au mur à l'aide du dispositif de fixation fourni. Vérifier la pertinence et la solidité du mur afin de s'assurer que le mur puisse supporter la charge du meuble et résister aux forces générées au niveau des fixations. Un montage mal effectué peut provoquer la chute du meuble/objet et des blessures graves sur les personnes. En cas de doute concernant l'installation, demandez conseil à un vendeur spécialisé ou contactez un professionnel.
*Utiliser des vis, rondelles et chevilles adaptées au type de matériau de votre mur. Celles-ci ne sont pas incluses. Pour obtenir des conseils sur les vis et ferrures adaptées à votre mur, adressez-vous à un vendeur spécialisé.
- ES** ADVERTENCIA : Para evitar cualquier riesgo de que se vuelque, el mueble u objeto debe anclarse firmemente a la pared, mediante el dispositivo de sujeción que se adjunta. Compruebe la adecuación y la solidez de la pared para asegurarse de que puede soportar el peso del mueble y resistir las fuerzas que se produzcan en las fijaciones. Un montaje inadecuado puede causar la caída del mueble u objeto y que se produzcan daños corporales. En caso de duda en relación a la instalación, pregunte a un vendedor especializado o recurra a un profesional.
*Utilice tornillos, arandelas y tacos adecuados para el material de la pared. El producto no incluye la tornillería ni los tacos de sujeción. Para saber cuáles son los elementos de fijación más adecuados para su pared, pregunte a un vendedor especializado.
- PT** AVISO : Para evitar qualquer risco de basculamento, este móvel/objeto deve ser fixo à parede de forma segura, utilizando o dispositivo de fixação fornecido. Verifique a adequabilidade e solidez da parede para se certificar de que pode suportar a carga do móvel e resistir às forças aplicadas ao nível das fixações. Uma montagem mal feita pode originar a queda do móvel/objeto e provo-car danos pessoais graves. Em caso de dúvida em relação à instalação, peça aconselhamento a um vendedor especializado ou contacte um profissional.
*Utilize parafusos, anilhas e buchas adaptadas ao tipo de material da sua parede. Estes elementos de fixação não estão incluídos. Para obter aconselhamento sobre os parafusos e ferragens adaptados à sua parede, consulte um vendedor especializado.
- IT** ATTENZIONE : Per evitare un eventuale rischio di ribaltamento, il mobile/l'oggetto deve essere saldamente fissato alla parete, mediante il dispositivo di fissaggio fornito. Verificare l'adeguatezza e la solidità della parete per essere sicuri che la stessa possa sopportare il carico del mobile e resistere alle forze generate a livello di fissaggi. Un montaggio non effettuato correttamente può provocare la caduta del mobile/dell'oggetto e lesioni gravi alle persone. In caso di dubbio circa l'installazione, rivolgetevi a un venditore specializzato o contattate un professionista.
*Utilizzare viti, rondelle e pernotti (non inclusi) adeguati al tipo di materiale della vostra parete. Per informazioni su viti e ferramenta adatti alla vostra parete, rivolgetevi a un venditore specializzato.
- EL** ΠΡΟΕΙΔΟΠΟΙΗΣΗ: Για την αποφυγή οποιουδήποτε κινδύνου ανατροπής, το έπιπλο/αντικείμενο πρέπει να στερεώνεται σταθερά στον τοίχο. Βεβαιωθείτε για την καταλληλότητα και σταθερότητα του τοίχου, προκειμένου να διασφαλίσετε ότι μπορεί να υποστηρίξει το φορτίο του επίπλου/αντικειμένου και να αντέξει στις δυνάμεις που δημιουργούνται στα σημεία των στηριγμάτων. Η κακή τοποθέτηση μπορεί να οδηγήσει σε πτώση του επίπλου/ αντικειμένου και σοβαρούς τραυματισμούς ατόμων. Σε περίπτωση αμφιβολίας σχετικά με την εγκατάσταση, ζητήστε συμβουλές από έναν εξειδικευμένο πωλητή ή καλέστε έναν επαγγελματία.
*Χρησιμοποιήστε κατάλληλες βίδες, ροδέλες και ούπα ανάλογα με το υλικό της τοιχοποιίας σας. Τα υλικά αυτά δεν περιλαμβάνονται.
Για συμβουλές σχετικά με τις βίδες και τα μεταλλικά στηρίγματα που ενδείκνυνται για τον τοίχο σας, απευθυνθείτε σε έναν εξειδικευμένο επαγγελματία.
- PL** OSTRZEŻENIE: Aby uniknąć ryzyka przewrócenia, mebel/produkt musi zostać solidnie przymocowany do ściany. Sprawdź, czy ściana jest odpowiednia i solidna, aby mieć pewność, że jest w stanie utrzymać obciążenie mebla/produktu i siły na poziomie mocowań. Nieprawidłowo wykonany montaż może spowodować upadek mebla/produktu prowadzący do poważnych obrażeń ciała. W razie wątpliwości dotyczących montażu, należy zasięgnąć porady u kompetentnego sprzedawcy lub skontaktować się z fachowcem.
*Użyj śrub, podkładek i kołków odpowiednich do rodzaju ściany. Elementy te nie są dołączone do zestawu. Aby zasięgnąć porady na temat odpowiednich śrub i okuć należy skontaktować się z kompetentnym sprzedawcą.

UA ПОПЕРЕДЖЕННЯ: Для уникнення ризику звалювання необхідно надійно прикріпити меблі/предмет до стіни за допомогою кріпильного пристрою, що постачається в комплекті. Перевірте міцність і функціональну придатність стіни та переконайтеся в тому, що вона зможе витримати вагу меблів/предмета й навантаження в місцях кріплення. Невідповідно виконаний монтаж може привести до падіння меблів/предмета й серйозного травмування людей. Якщо у вас виникли сумніви щодо установки, зверніться до продавця спеціалізованого магазину або зв'яжіться зі спеціалістом.

*Використовуйте відповідні до типу стіни гвинти, шайби та штифти. Вони не постачаються в комплекті. Для отримання рекомендацій стосовно відповідних для типу стіни гвинтів і арматури зверніться до спеціалізованого магазину.

RO AVERTIZARE: Pentru a preveni răsturnarea, acest mobilier/acest obiect trebuie fixat în siguranță pe perete cu ajutorul dispozitivului de fixare furnizat. Verificați dacă peretele este adecvat și dacă este rezistent, pentru a vă asigura că acesta poate suporta greutatea mobilei/obiectului și că poate rezista la forțele generate la nivelul elementelor de fixare. Instalarea incorectă poate cauza căderea mobilierului și rănirea gravă a persoanelor. În cazul în care aveți îndoieli cu privire la instalare, cereți sfatul unui distribuitor specializat sau contactați un profesionist.

*Utilizați șuruburi, șaibe și știfturi adaptate tipului de material a peretelui. Acestea nu sunt incluse. Pentru a obține recomandări privind șuruburile și felurile adaptate peretelui dvs., adresați-vă unui comerciant specializat.

BR AVISO: Para evitar todo risco de tombamento, esse gabinete deve ser fixado na parede de forma segura, usando o dispositivo de fixação fornecido. Verifique a adequabilidade e a resistência da parede para se certificar que possa suportar a carga do gabinete e resistir às forças aplicadas a nível das fixações. Uma montagem incorreta pode originar a queda do gabinete e provocar danos pessoais graves. Em caso de dúvida quanto à instalação, consulte um vendedor especializado ou contate um profissional.

*Use parafusos, arruelas e cavilhas adaptadas ao tipo de material da sua parede. Esses acessórios de fixação não estão incluídos. Para obter conselhos sobre os parafusos e acessórios adequados para sua parede, entre em contato com um revendedor especializado.

EN WARNING: To prevent tipping, this furniture must be securely fixed to the wall using the fixing device provided. Check the suitability and strength of the wall to ensure that the wall can support the load of the furniture and withstand the forces generated at the fixings. Incorrect installation can cause the furniture to fall and cause serious injury to people. If in doubt about the installation, ask a specialist dealer for advice or contact a professional.

*Use screws, washers and plugs that are suitable for the type of wall material. These are not included. For advice on which screws and fittings are suitable for your wall, please contact a specialist dealer.

FR Plan de la notice **ES** Esquema del folleto **PT** Plano de instruções
IT Piano delle istruzioni **EL** Σχέδιο οδηγιών **PL** Plan instrukcji
UA Огляд посібника **RO** Planul instrucțiunilor **BR** Esboço do folheto
EN Overview of the guide

600

01

FR : Matériel - ES : Material - PT : Material - IT : Materiale - EL : Υλικό
PL : Materiał - UA : Матеріал RO : Material - BR : Material
EN : Equipment



02

FR : Montage - ES : Montaje - PT : Montagem - IT : Montaggio
EL : Συναρμολόγηση - PL : Montaz - UA : Збірка - RO : Montaj
- BR : Montagem - EN : Assembly



1200

01

FR : Matériel - ES : Material - PT : Material - IT : Materiale - EL : Υλικό
PL : Materiał - UA : Матеріал RO : Material - BR : Material
EN : Equipment



02

FR : Montage - ES : Montaje - PT : Montagem - IT : Montaggio
EL : Συναρμολόγηση - PL : Montaz - UA : Збірка - RO : Montaj
BR : Montagem - EN : Assembly



600-1200

03

FR : Entretien - ES : Mantenimiento - PT : Manutenção - IT : Manutenzione
EL : Συντήρηση - PL : Konserwacja - UA : Технічне обслуговування
RO : Întreținere - BR : Manutenção - EN : Maintenance



FR IMPORTANT,
à conserver pour
consultation ultérieure :
à lire attentivement

ES IMPORTANTE,
conservar para consultar
posteriormente :
leer atentamente

PT IMPORTANTE,
conservar para futuras
consultas : por favor,
leia com atenção

IT IMPORTANTE,
da conservare per
ulteriore consultazione :
da leggere attentamente

EL ΣΗΜΑΝΤΙΚΟ,
κρατήστε το για
μελλοντική αναφορά.
Διαβάστε το προσεκτικά

PL WAŻNE,
do zachowania na
przyszłość: proszę
przeczytać uważnie

UA ВАЖЛИВО,
щоб бути зберегти на
майбутнє посилання:
будь ласка уважно
прочитайте

RO IMPORTANT,
a se pastra pentru
consultarea ulterioara:
citiți cu atenție

BR IMPORTANTE,
por favor manter para
referência futura:
leia com atenção.

EN IMPORTANT,
to be retained for
future reference:
please read carefully.

01

FR Matériel
IT Materiale
UA Матеріал
EN Equipment

ES Material
EL Υλικό
RO Material

PT Material
PL Materiał
BR Material

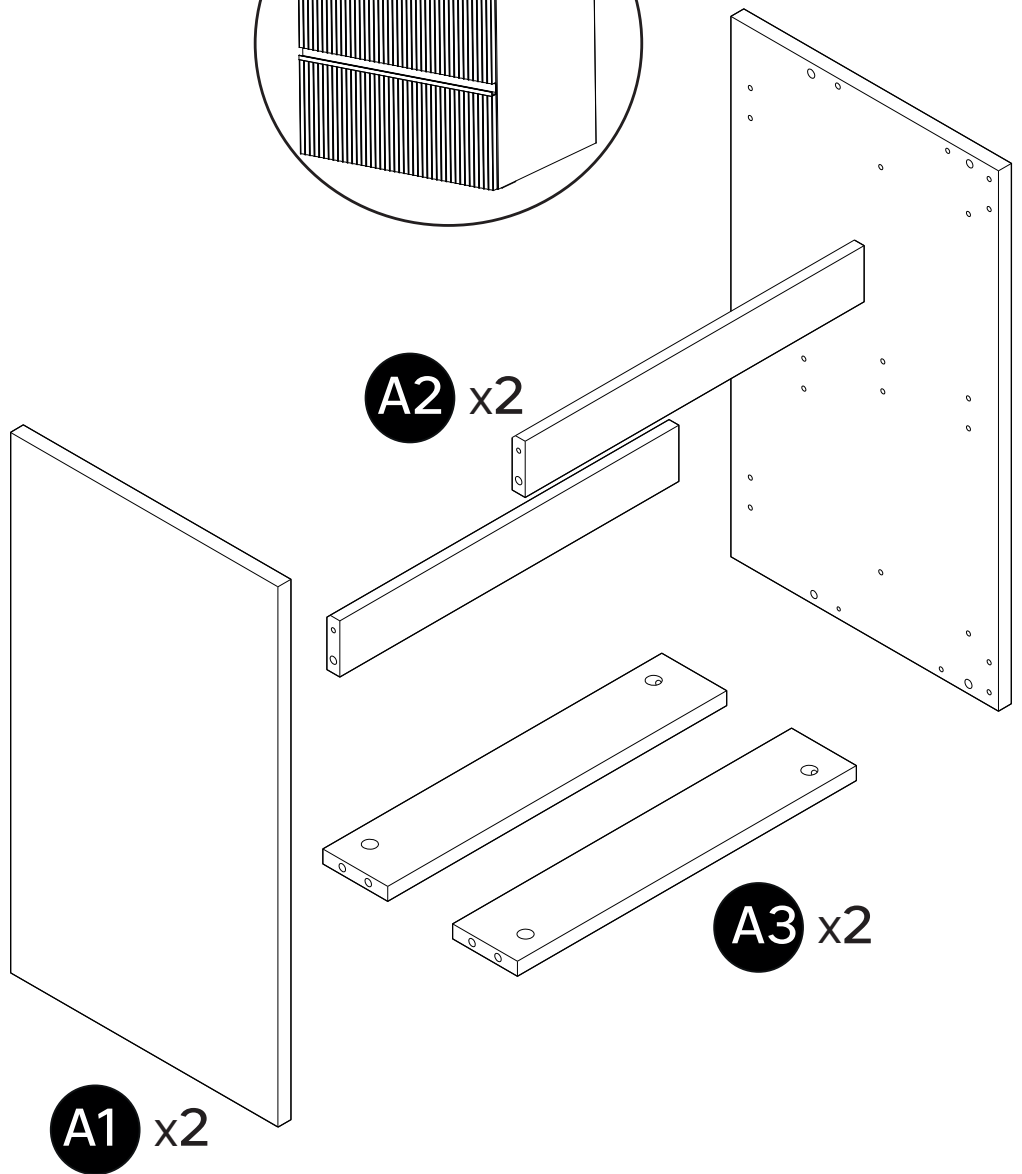
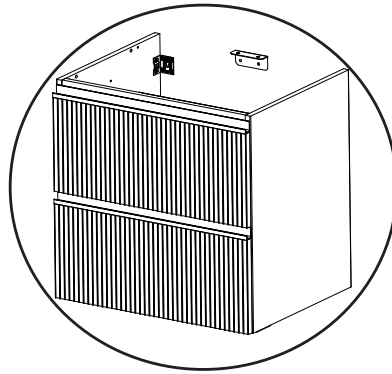

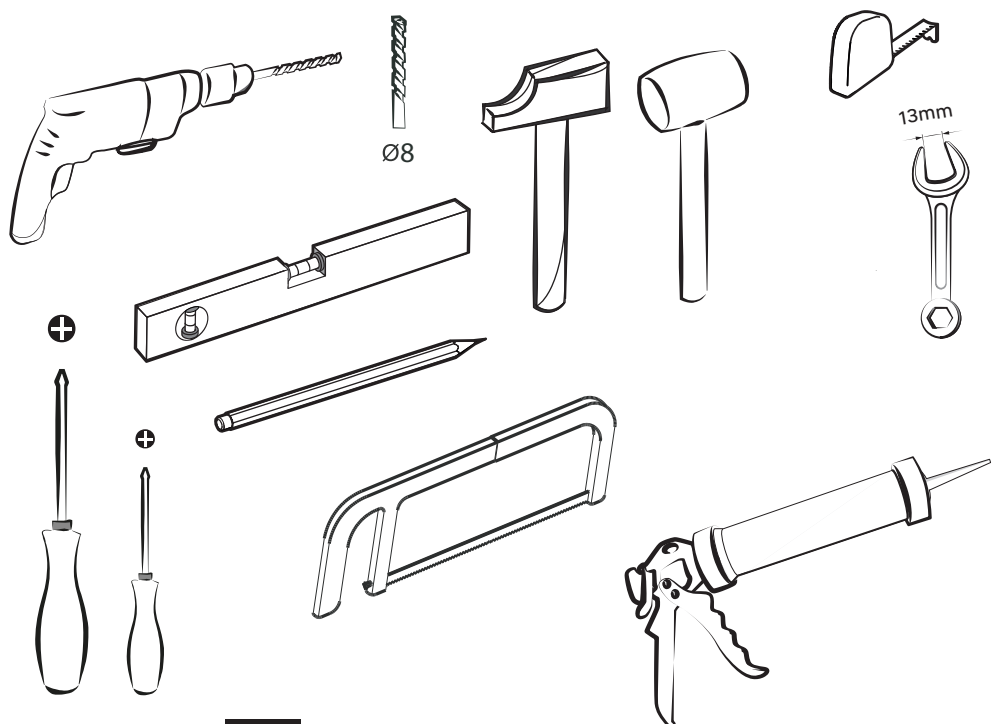
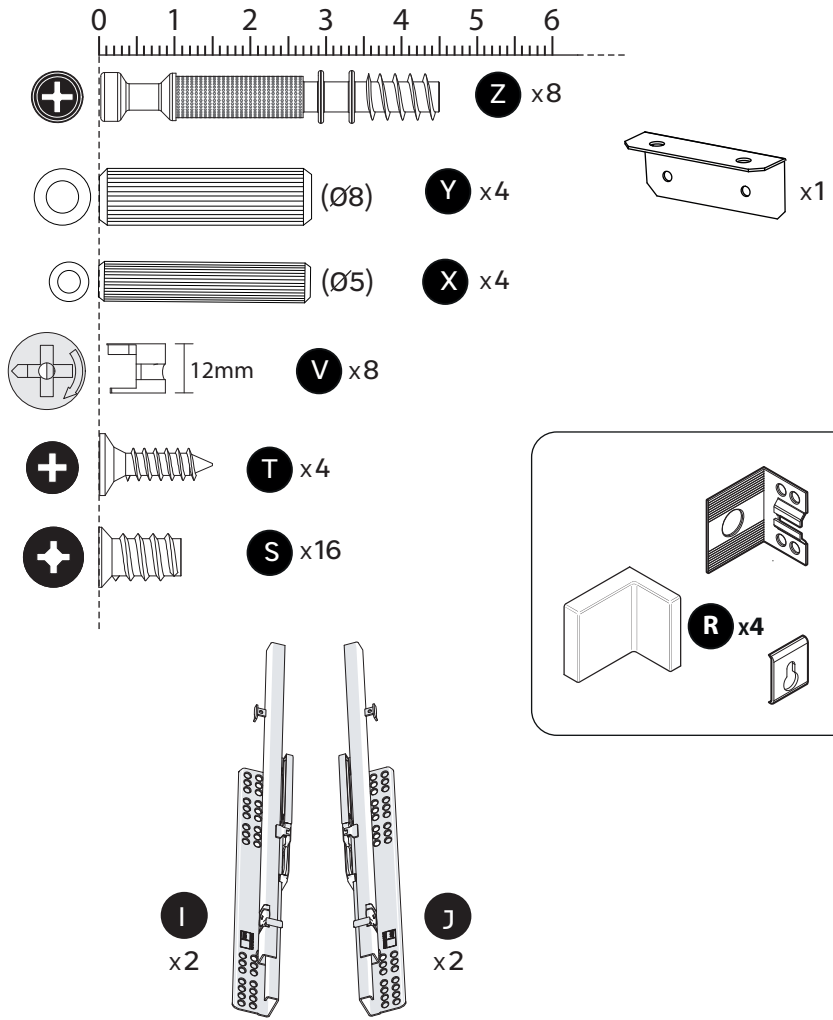

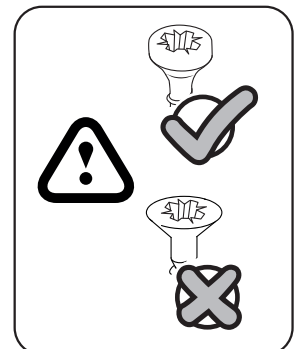
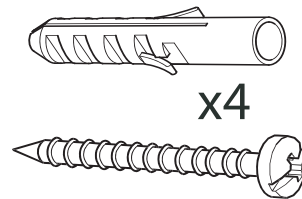
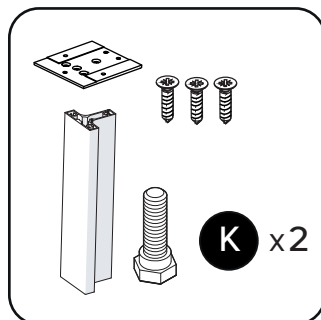
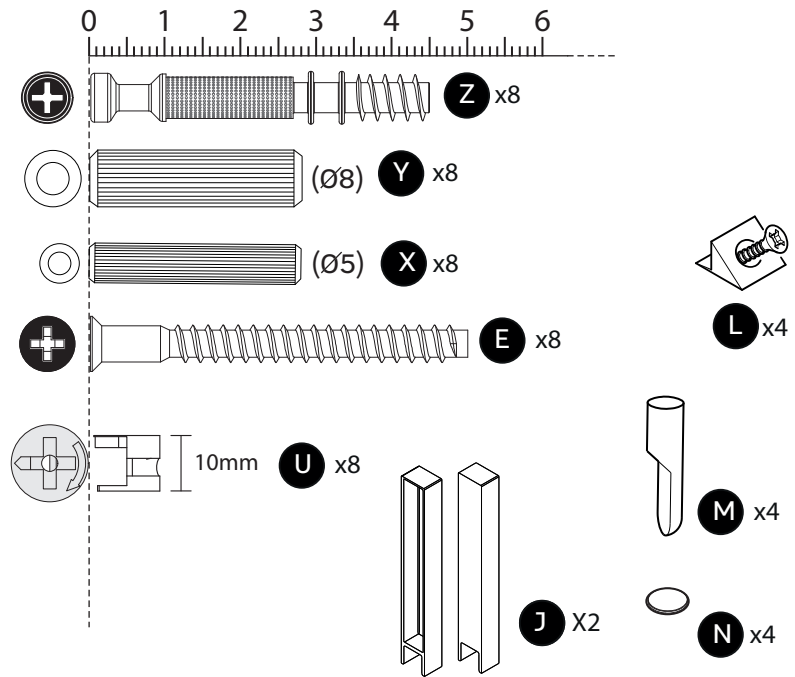
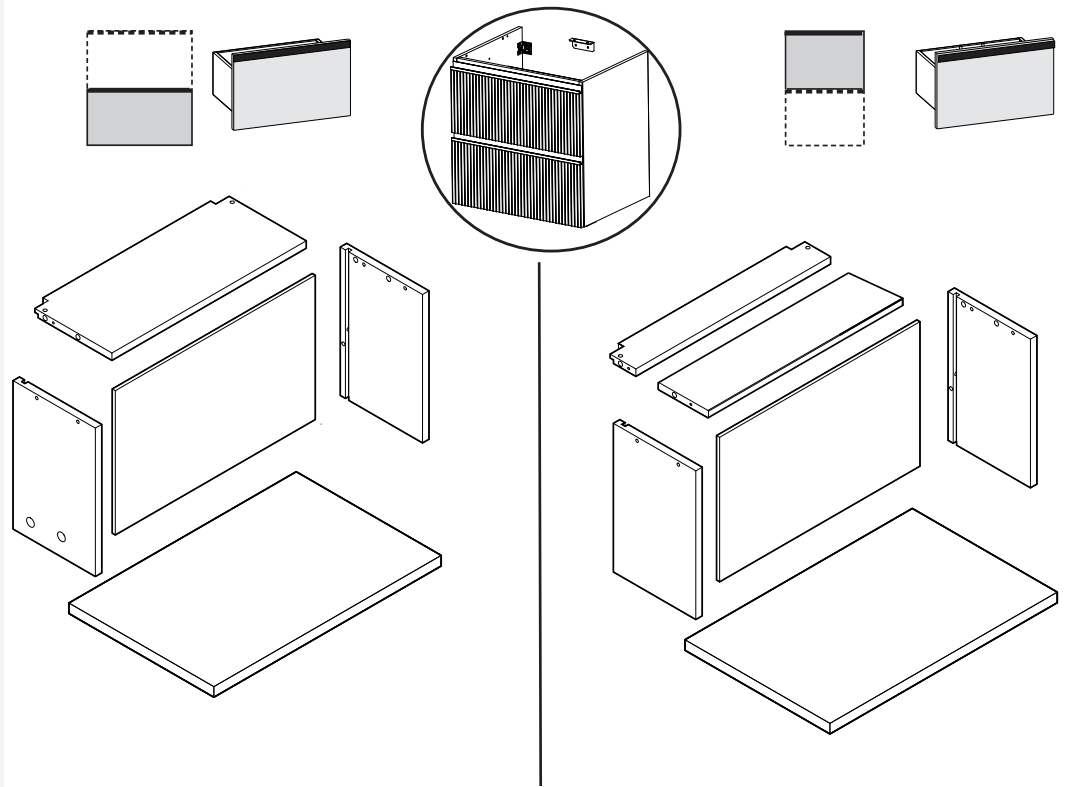

02

FR Montage
IT Montaggio
UA Збірка
EN Assembly

ES Montaje
EL Συναρμολόγηση
RO Montaj

PT Montagem
PL Montaż
BR Montagem

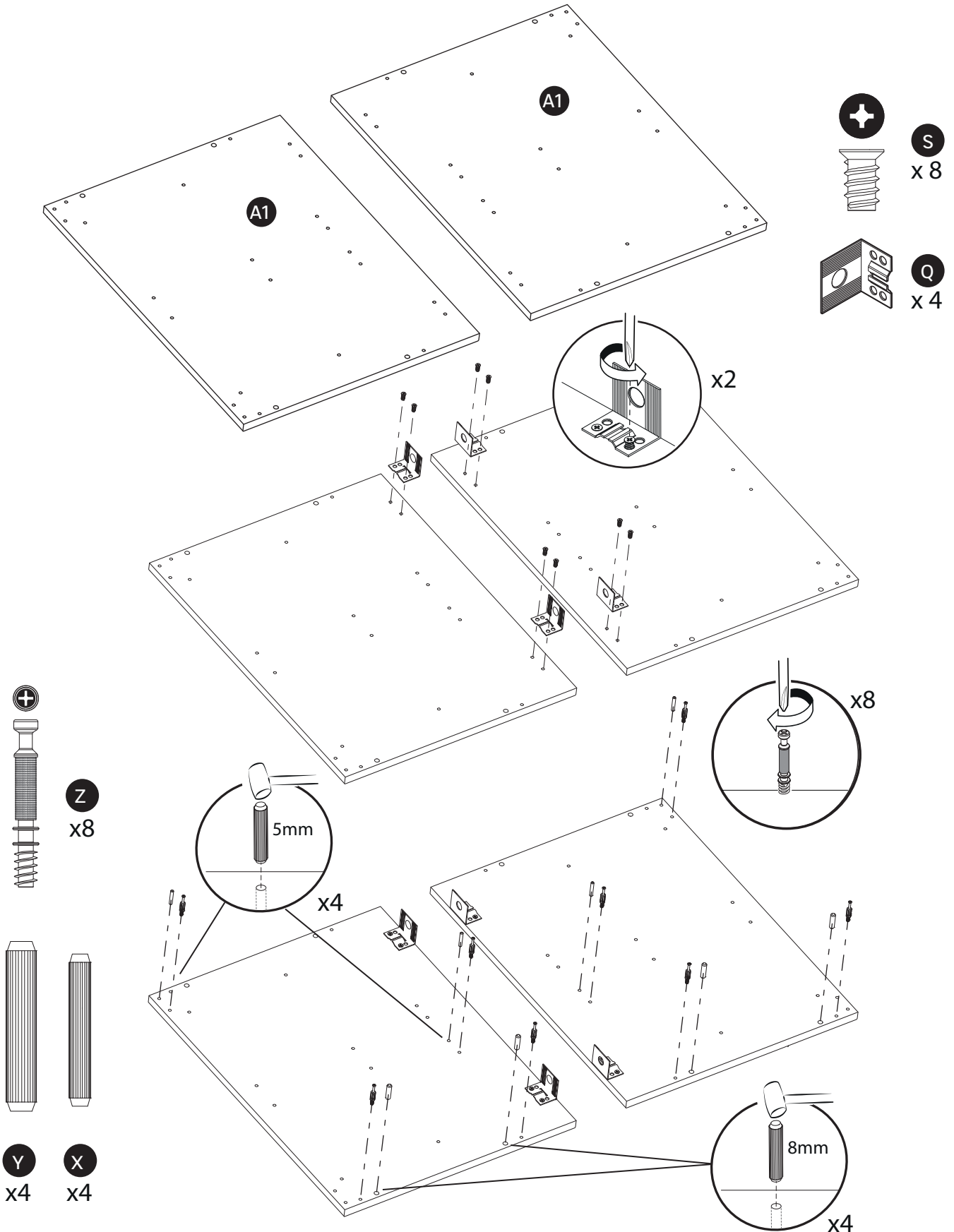

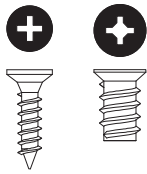

T
x4

S
x8

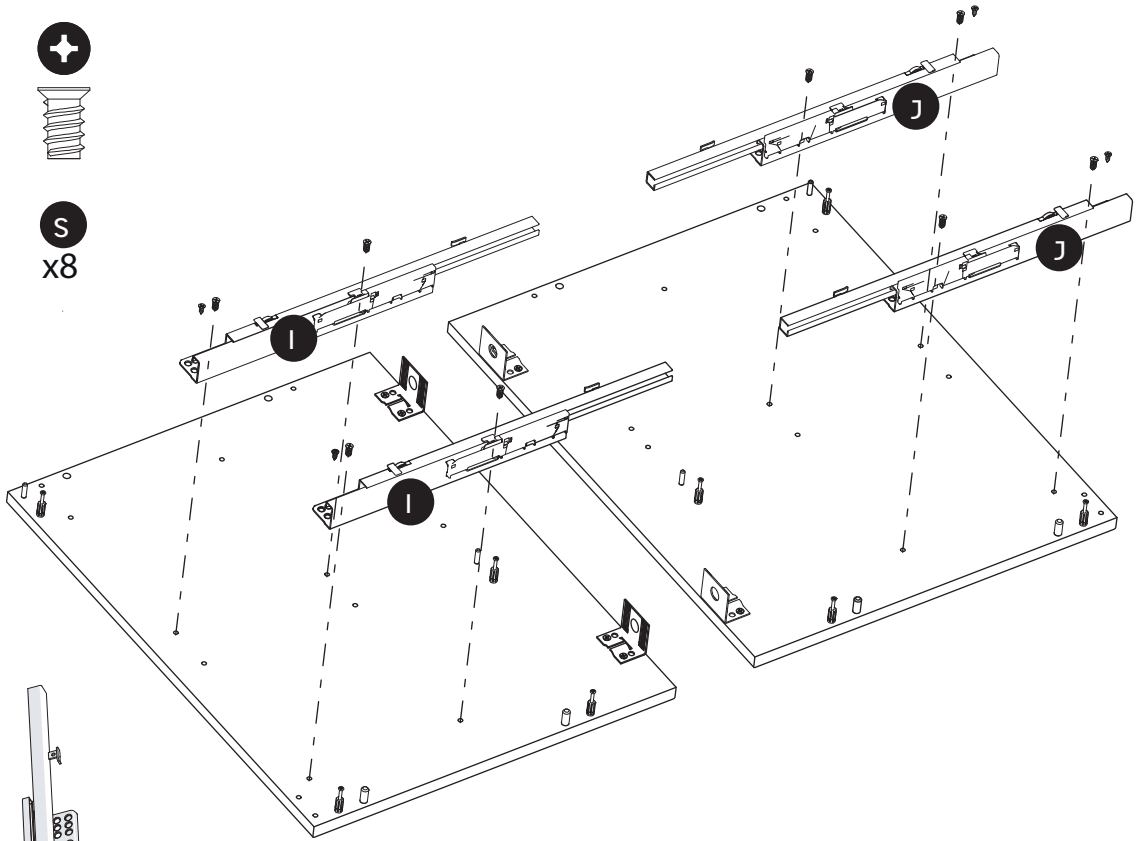

I
x2



J
x2

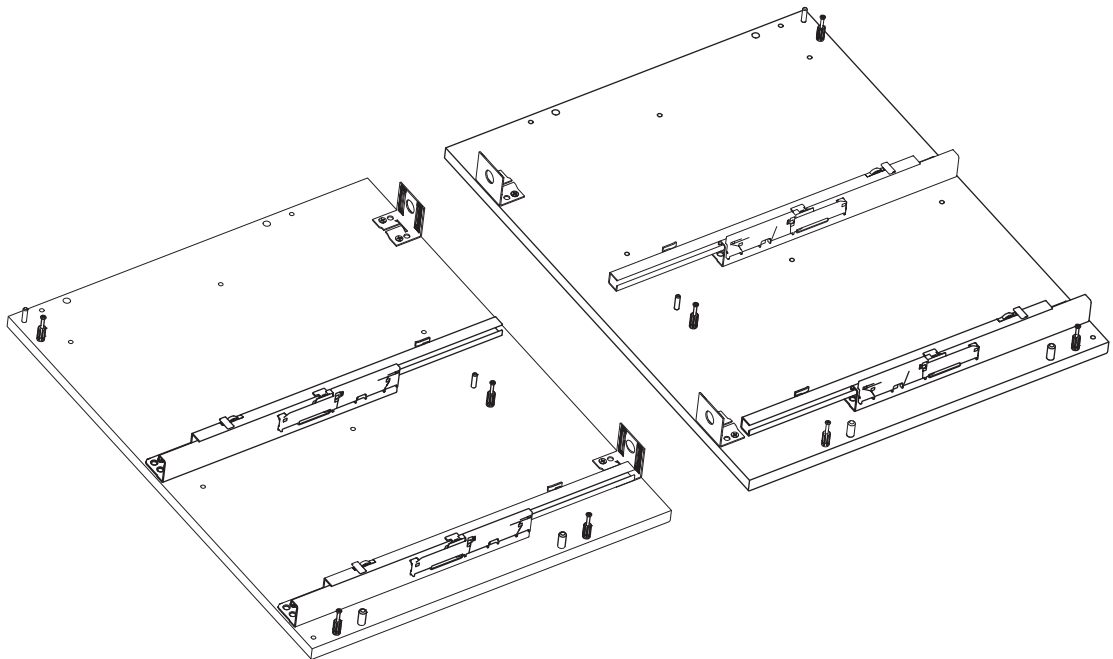
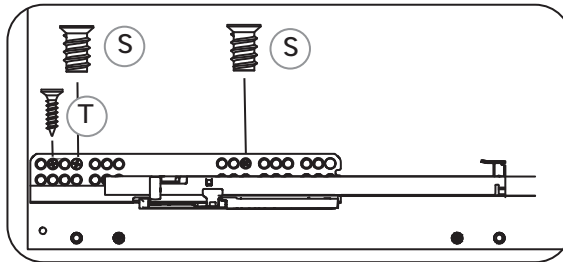
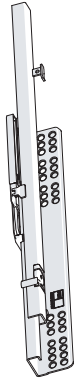

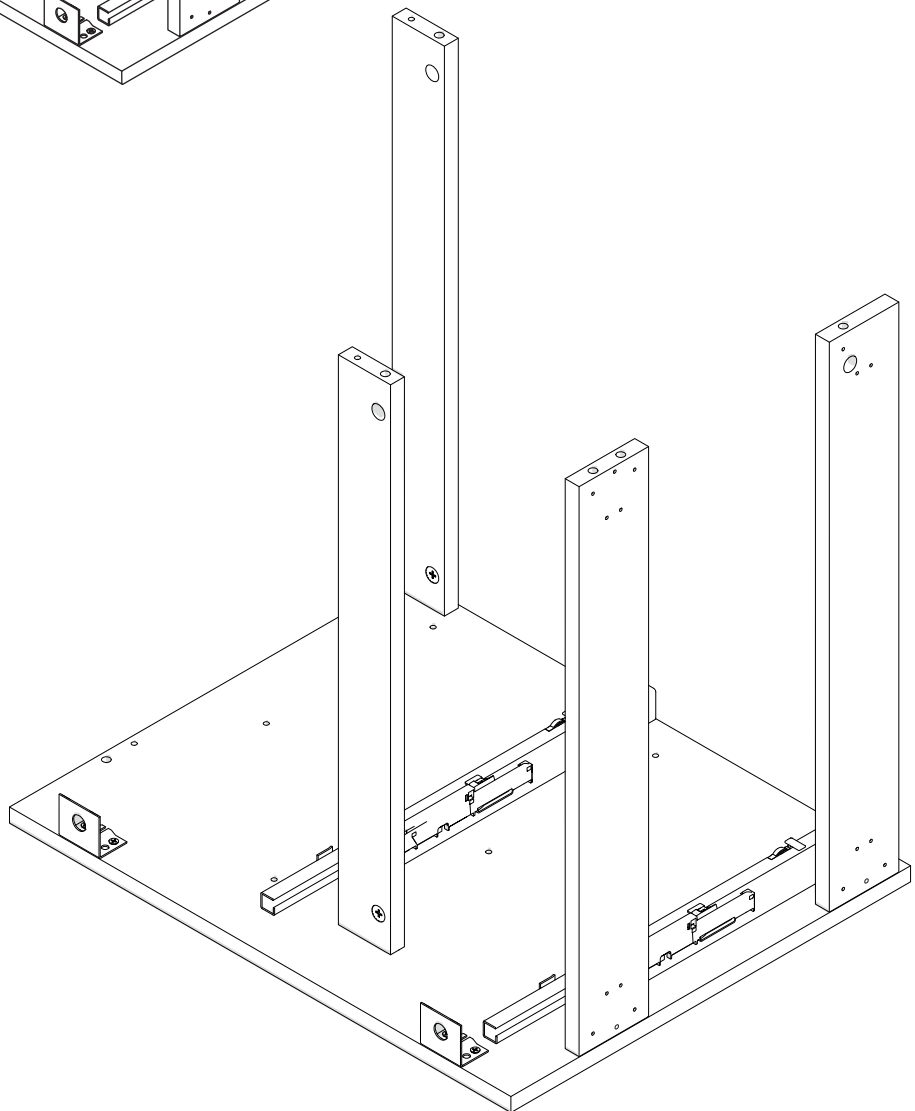
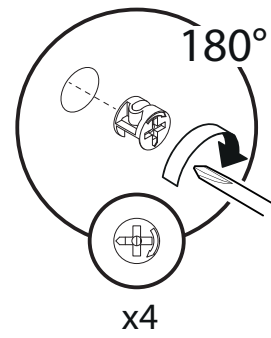
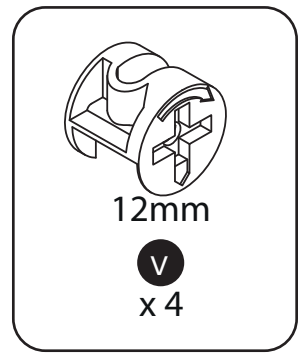
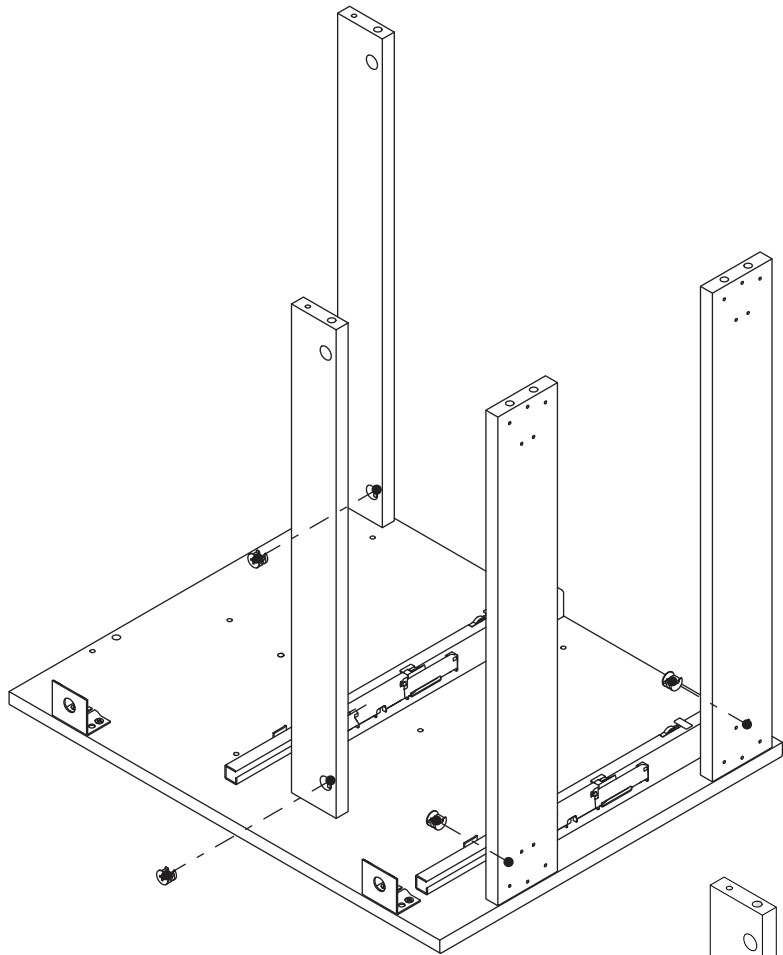

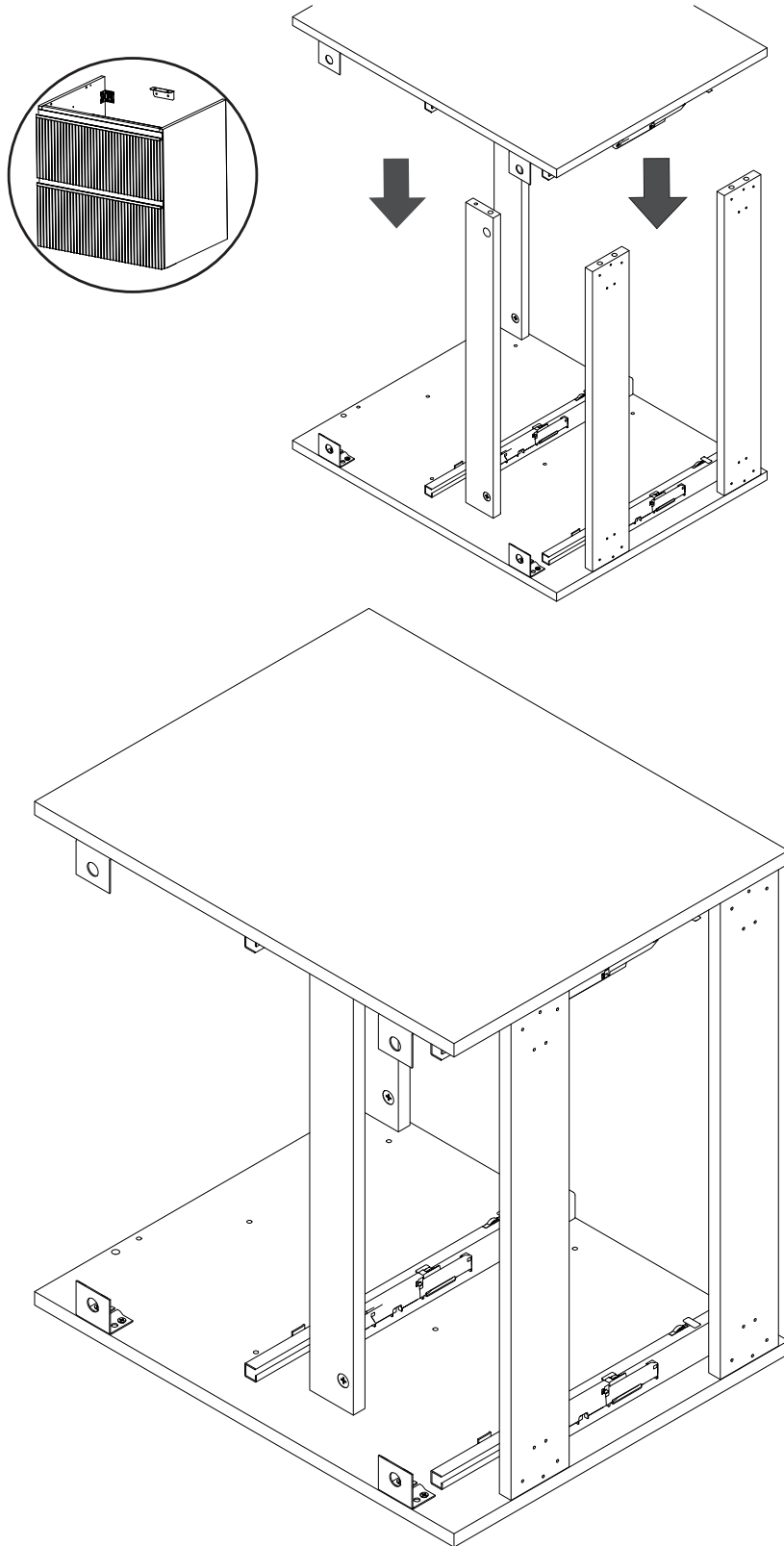
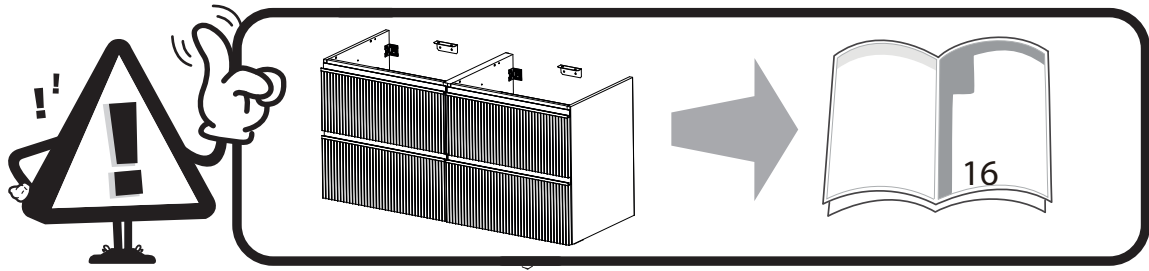

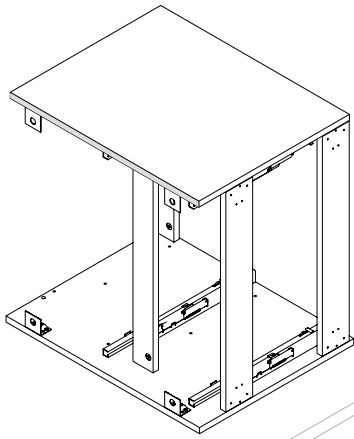

12mm

V

x 4

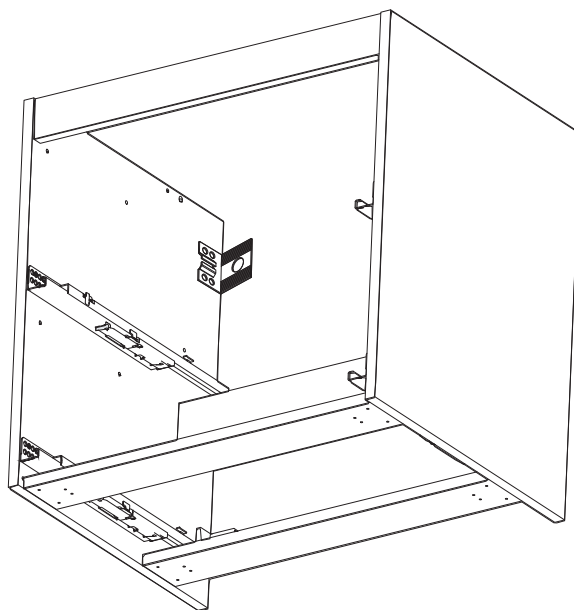
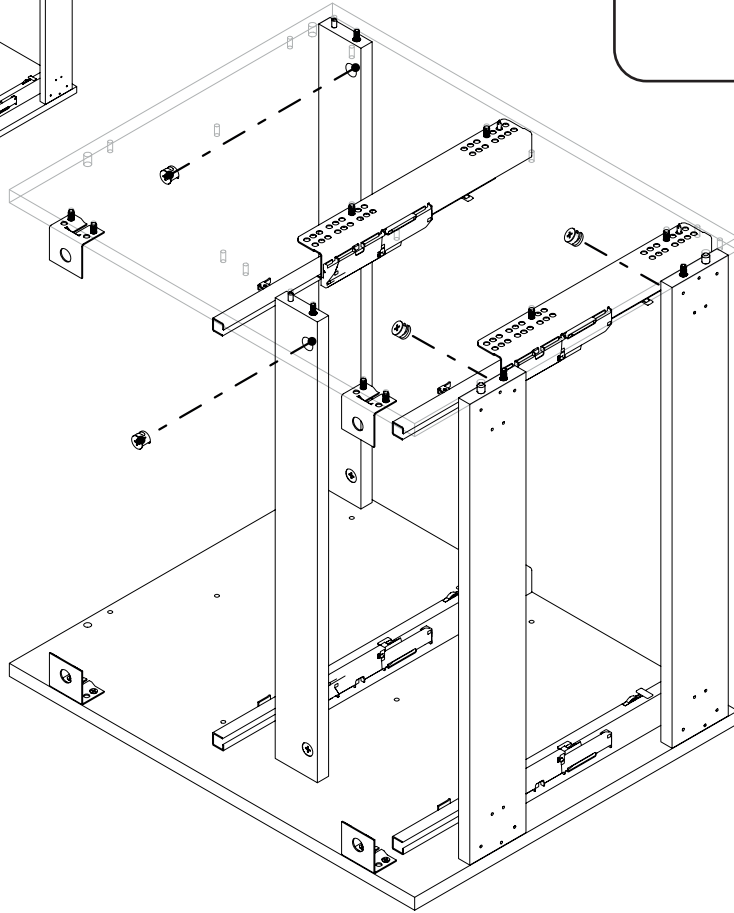
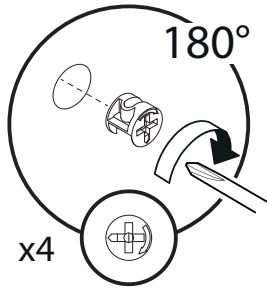

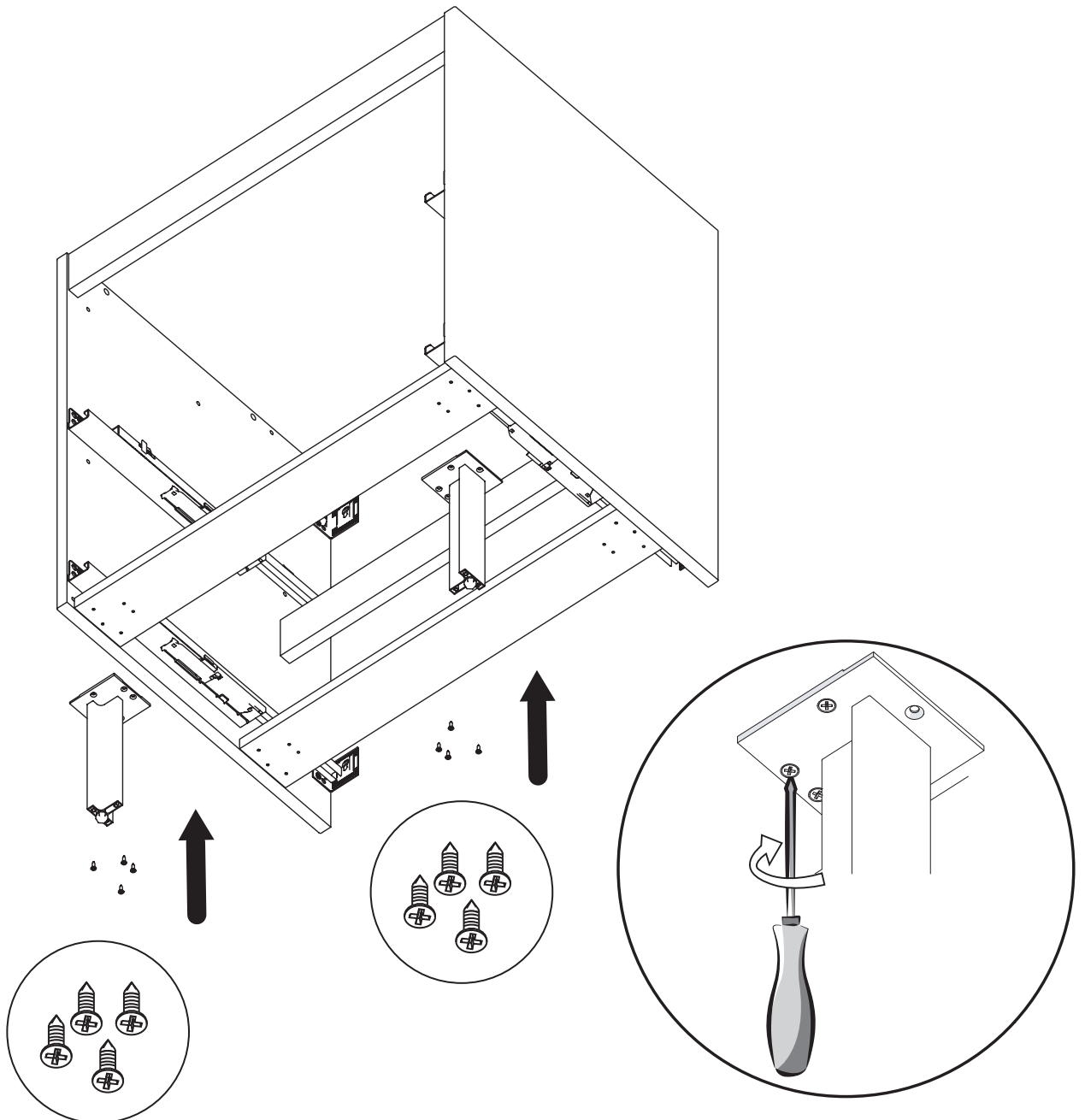
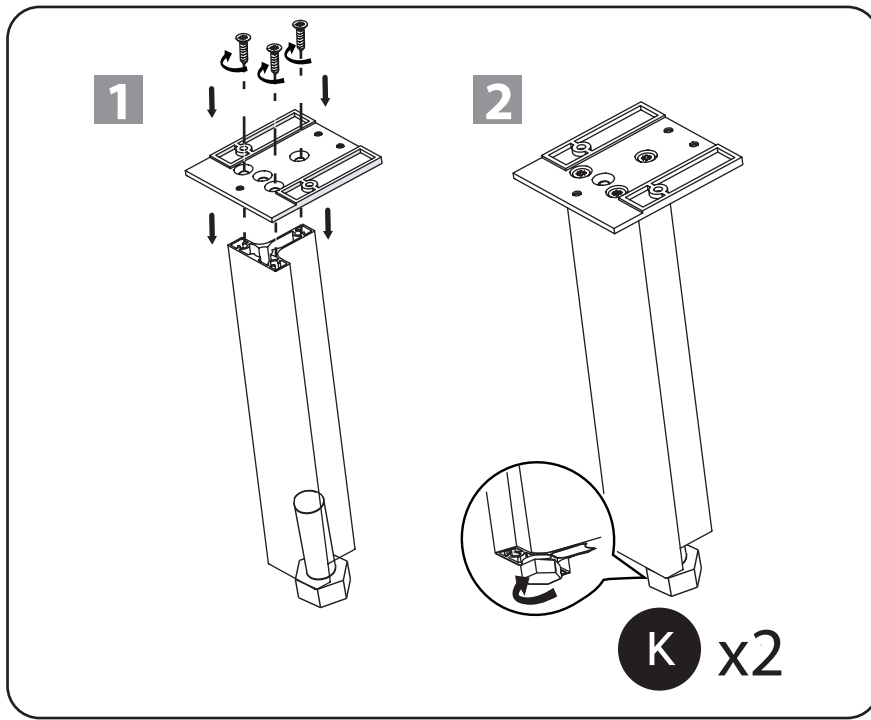

01

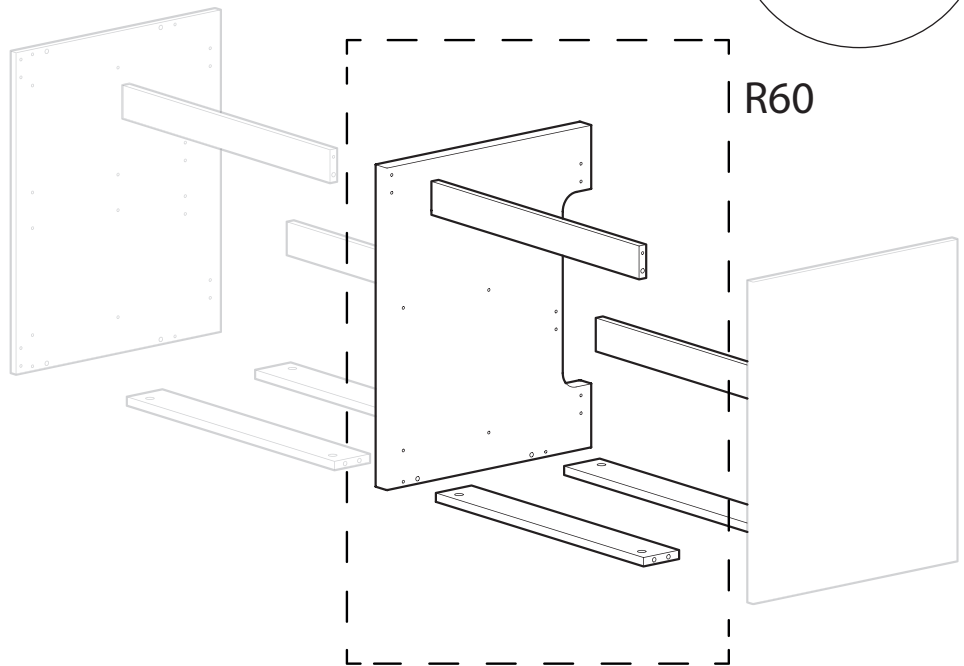
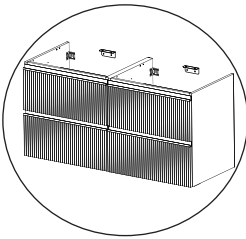

0 1 2 3 4 5 cm

+ **Z** x8

Y x4

X x4

+ **S** x8

12mm **V** x8

+ **T** x8

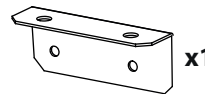

x1

I
x2

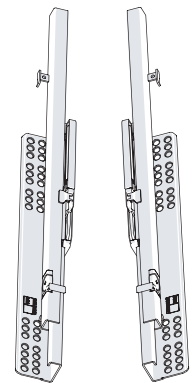

J
x2

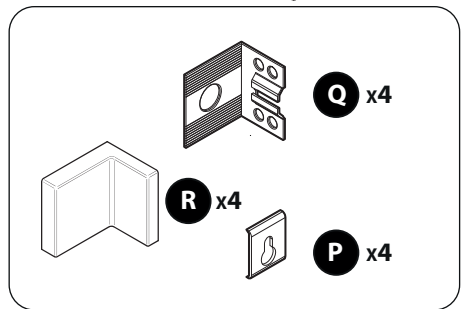

Q x4

R x4

P x4

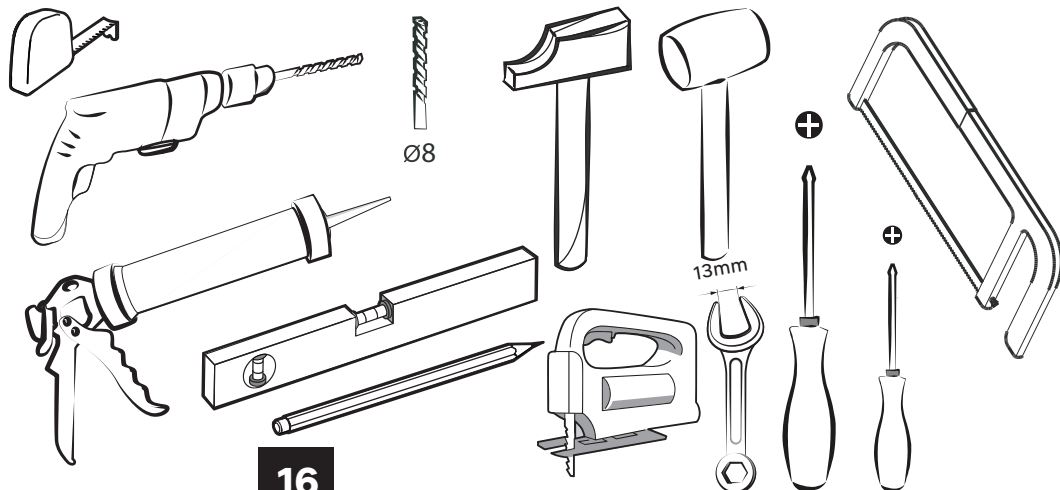

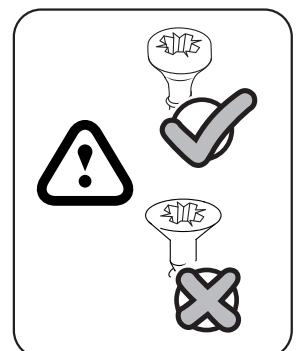
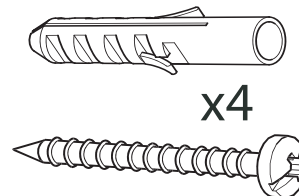
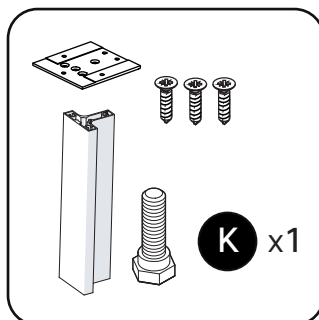
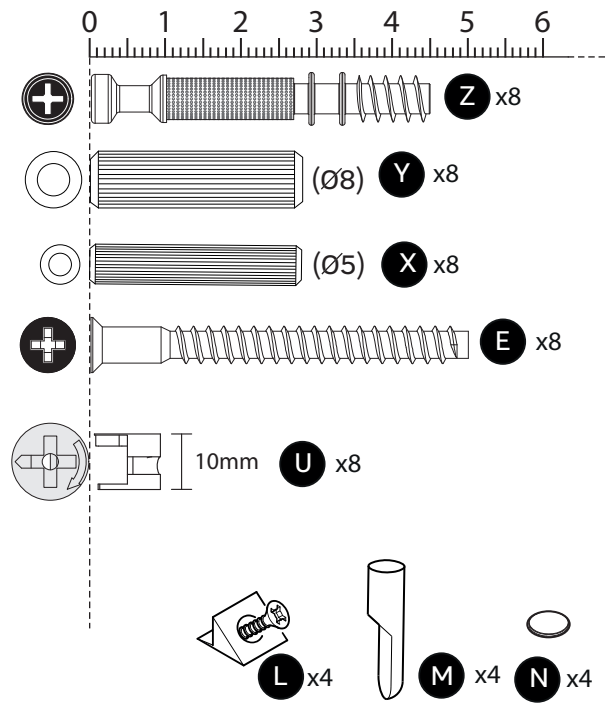
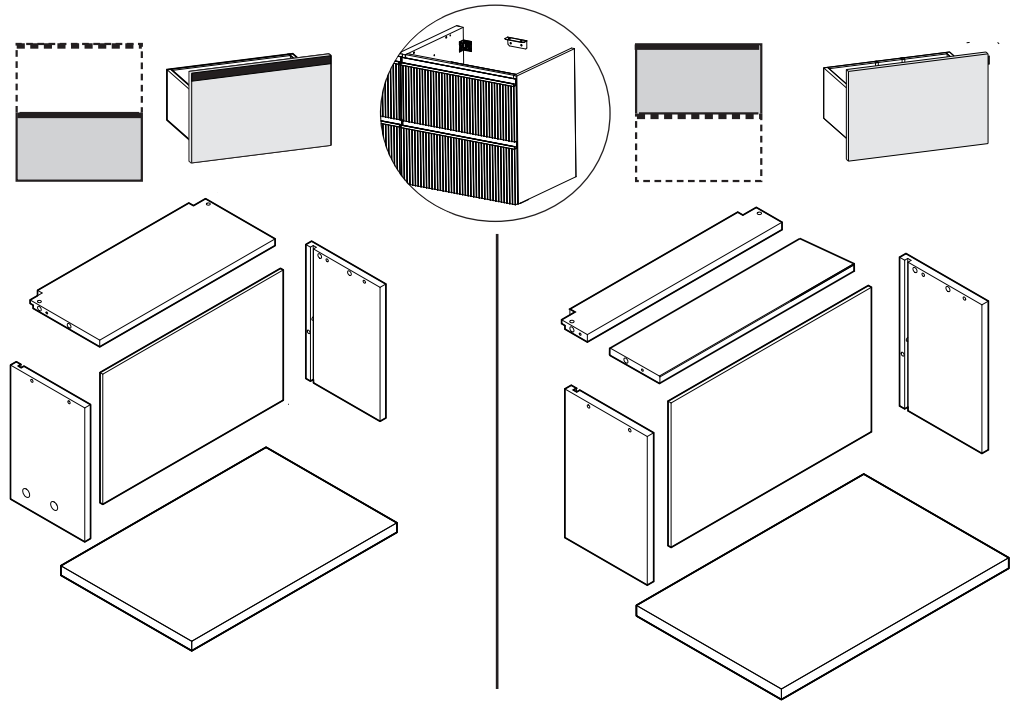

02

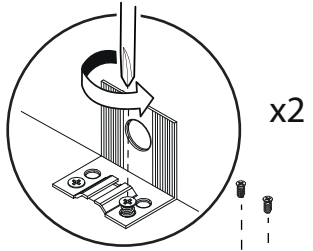
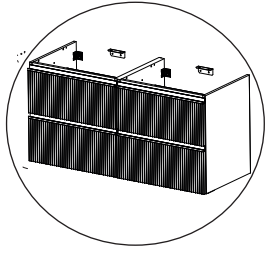

S
x4

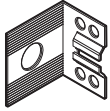

Q
x2

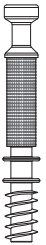
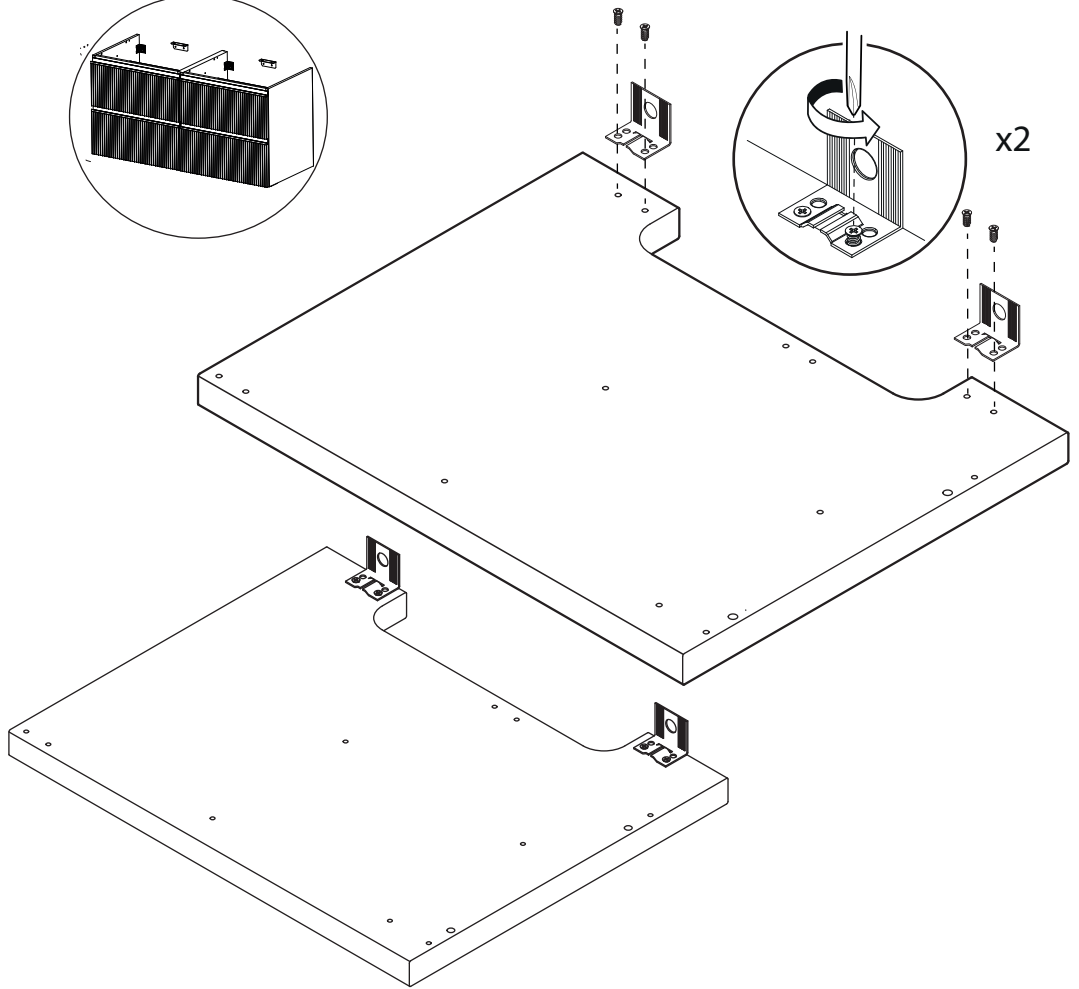

Z
x4

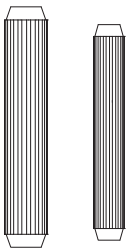
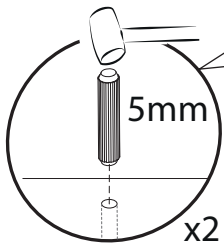
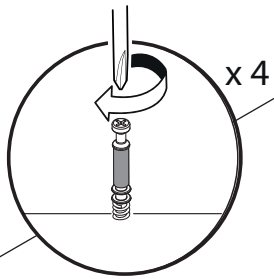

Y
x2

X
x2

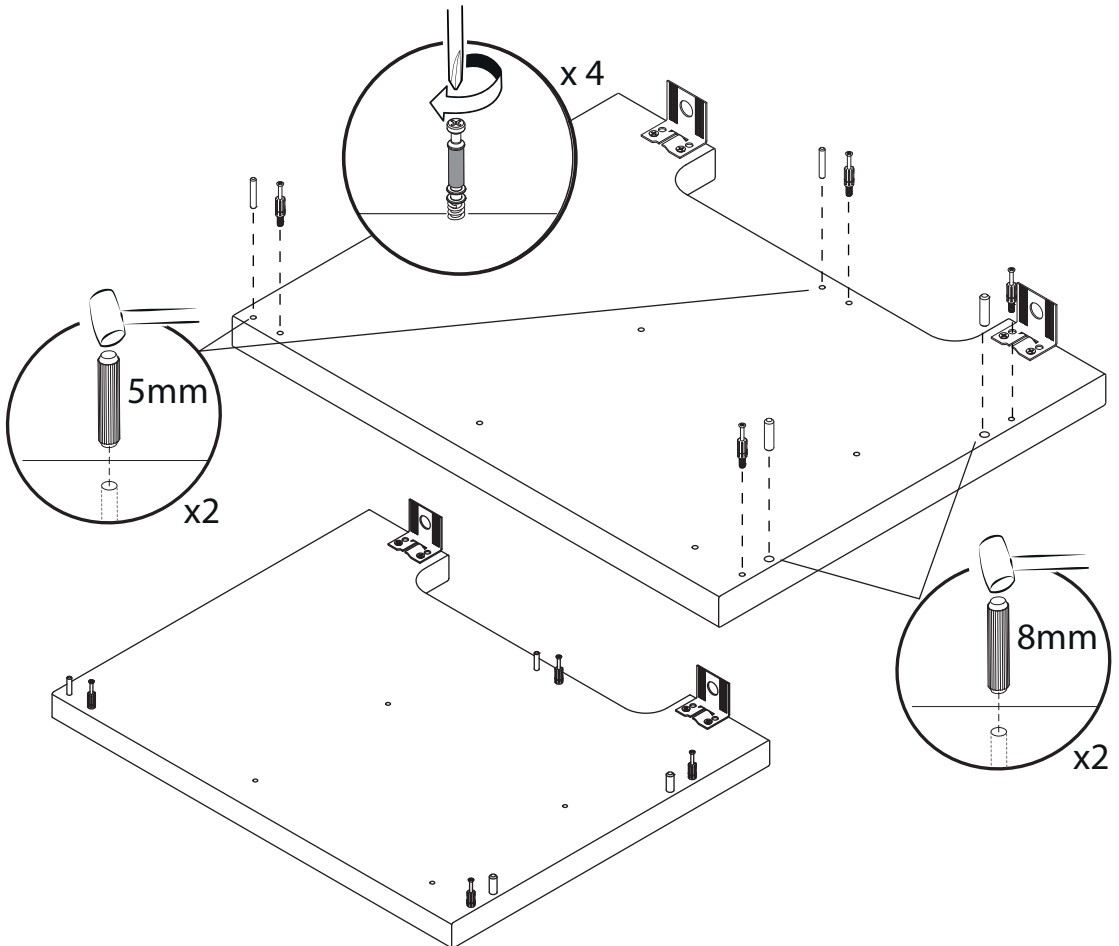

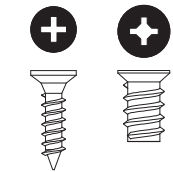

T x2
S x4

I x2

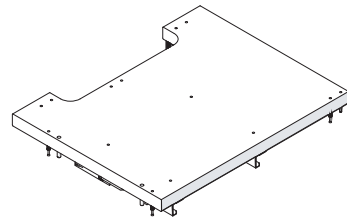
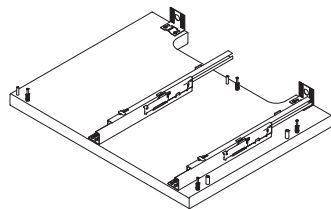
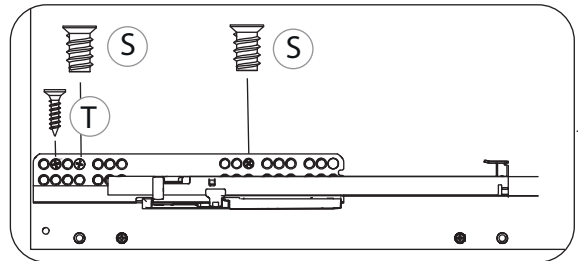
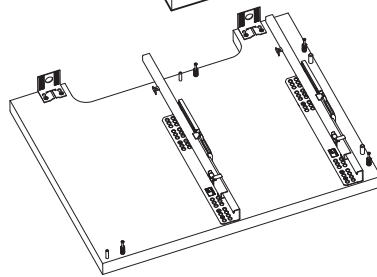
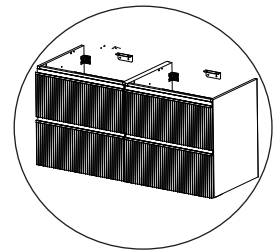
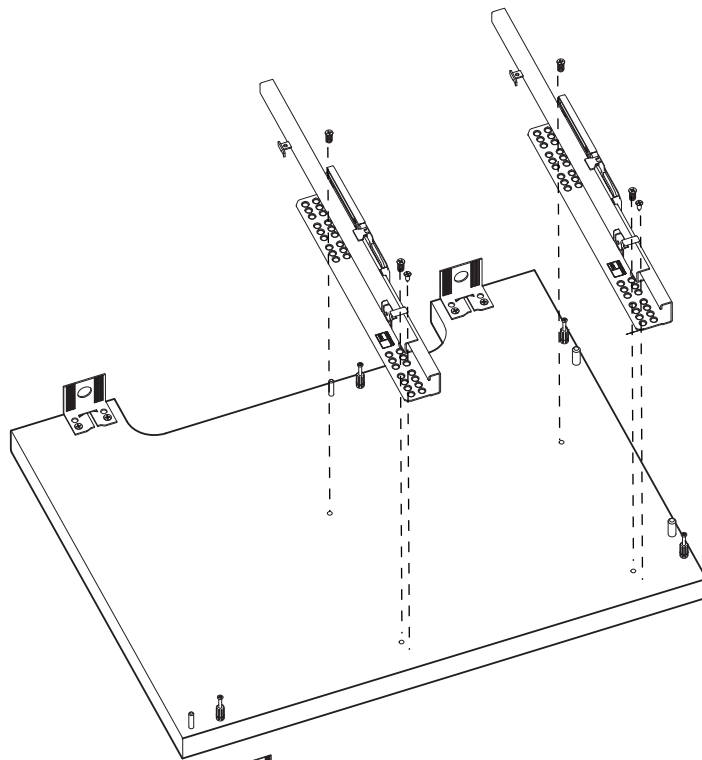

S x4



Q x2

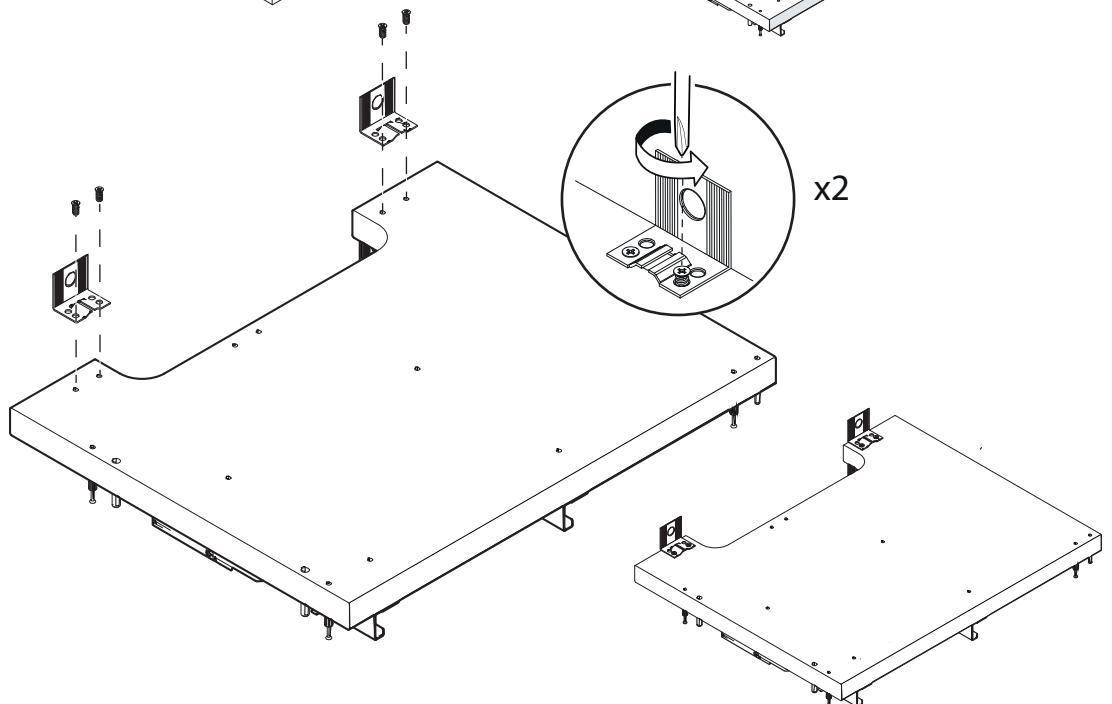

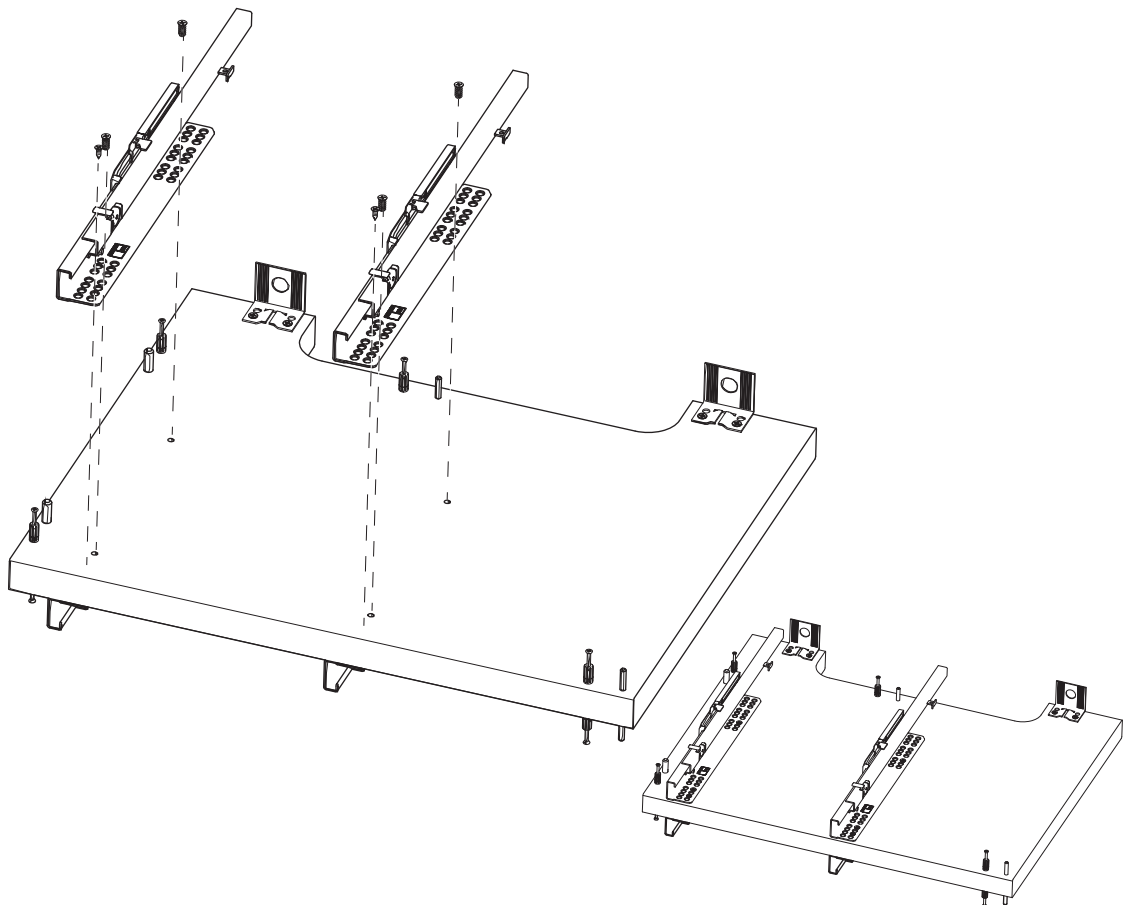
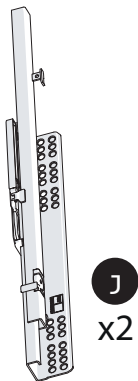
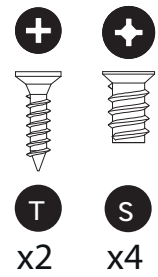
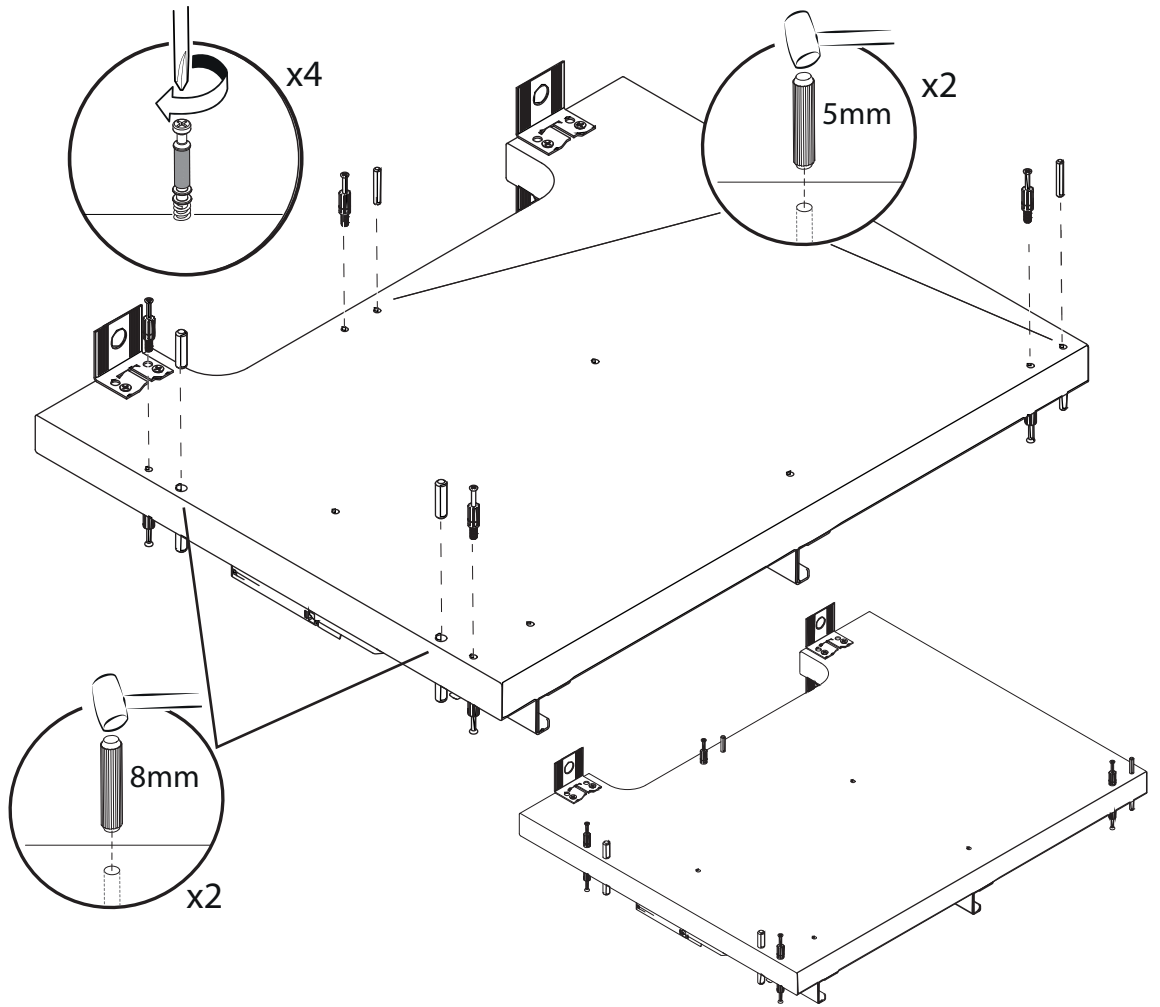
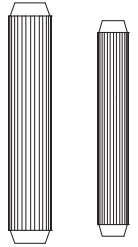
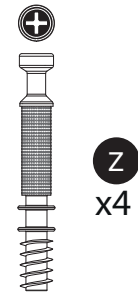

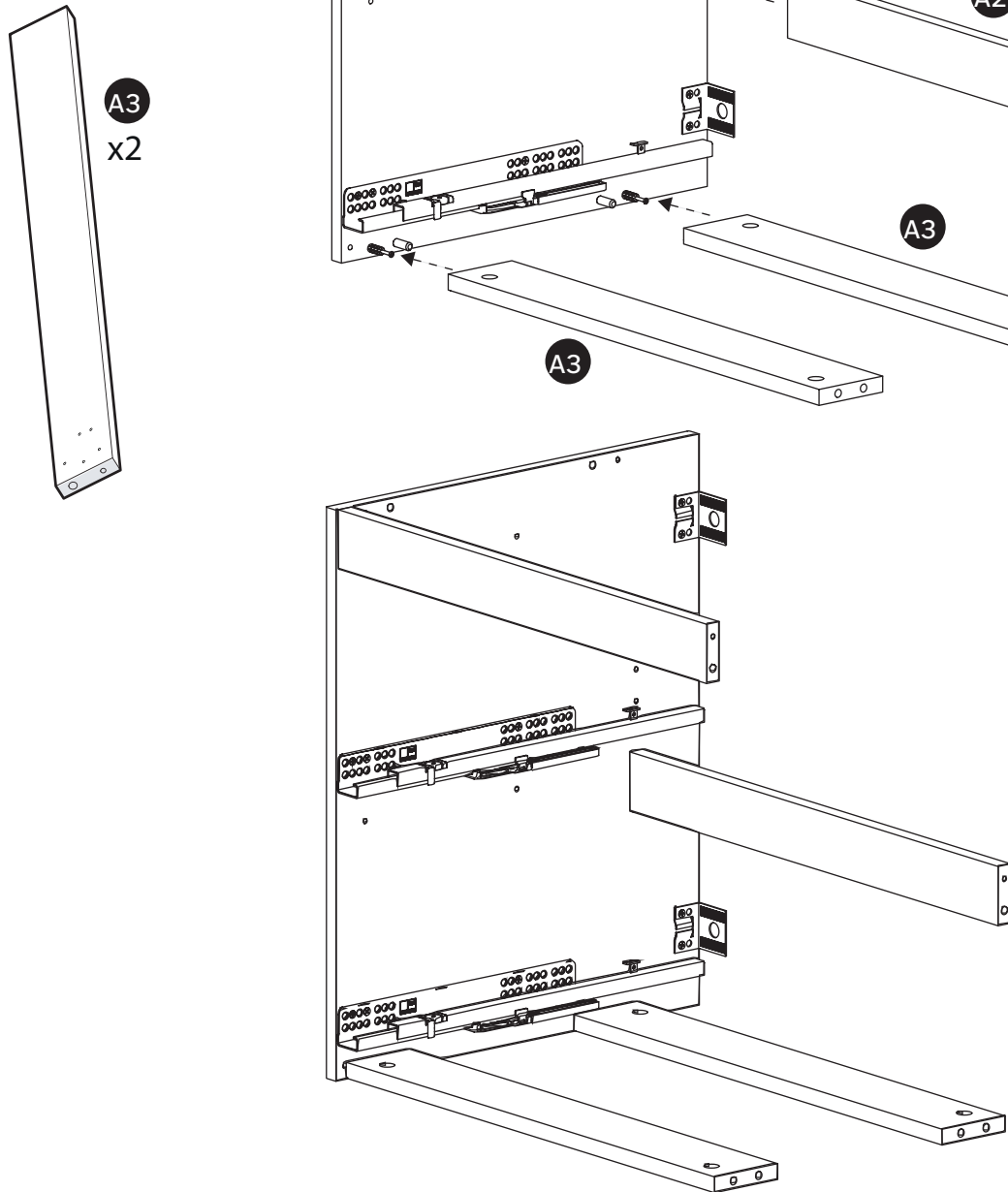
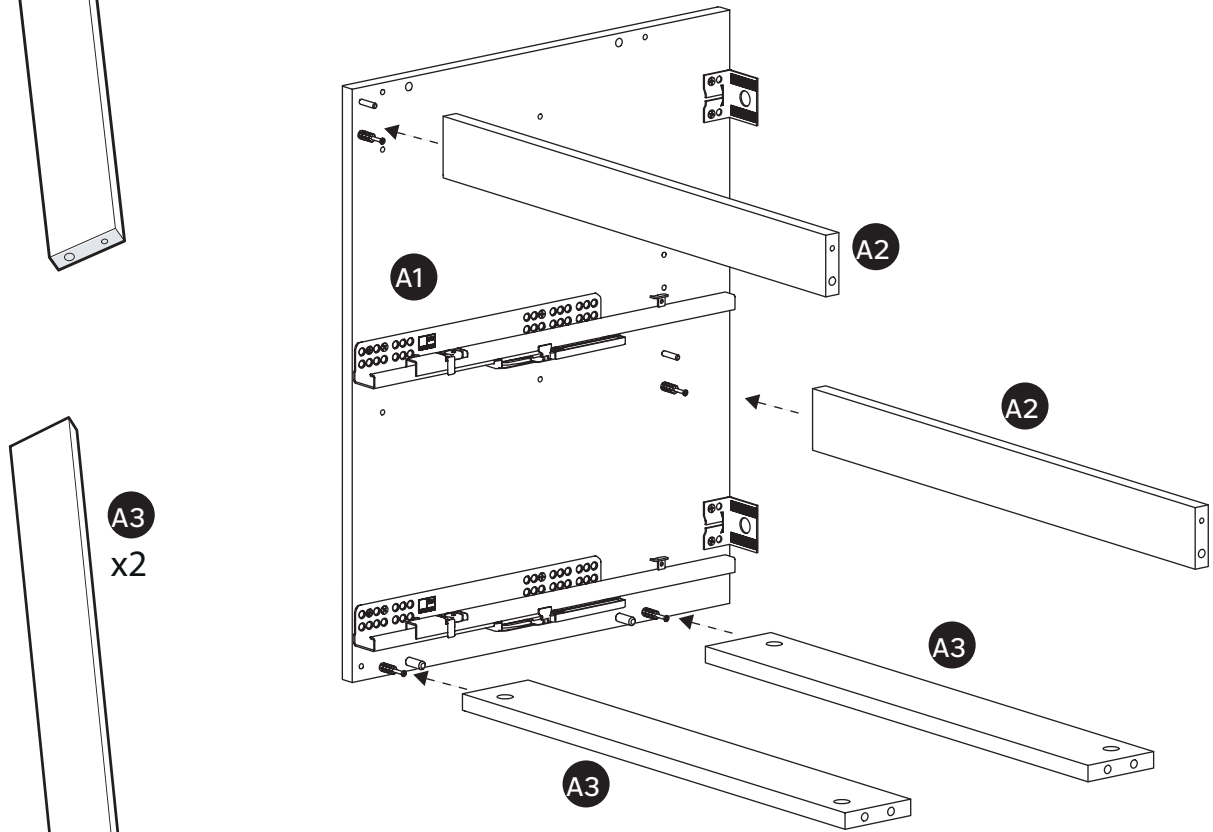
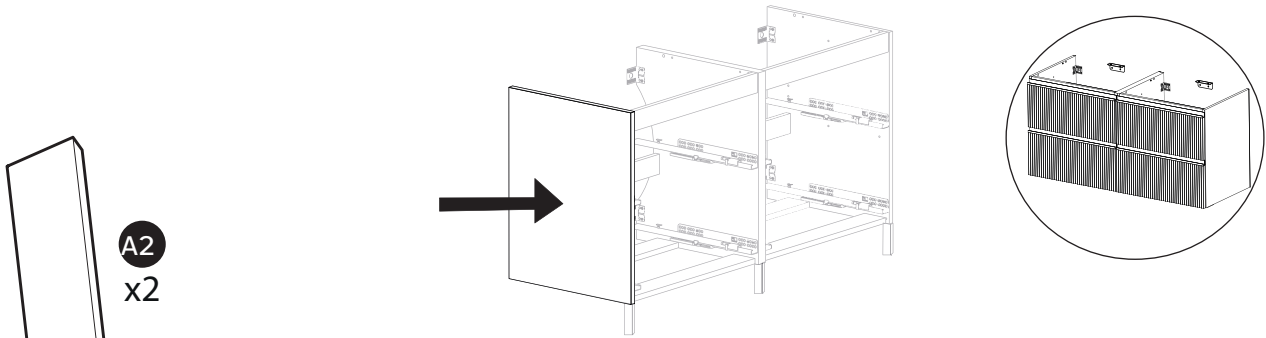

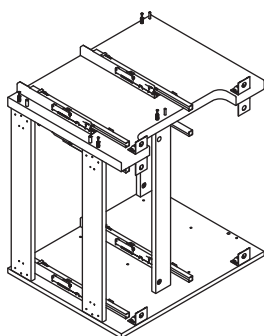
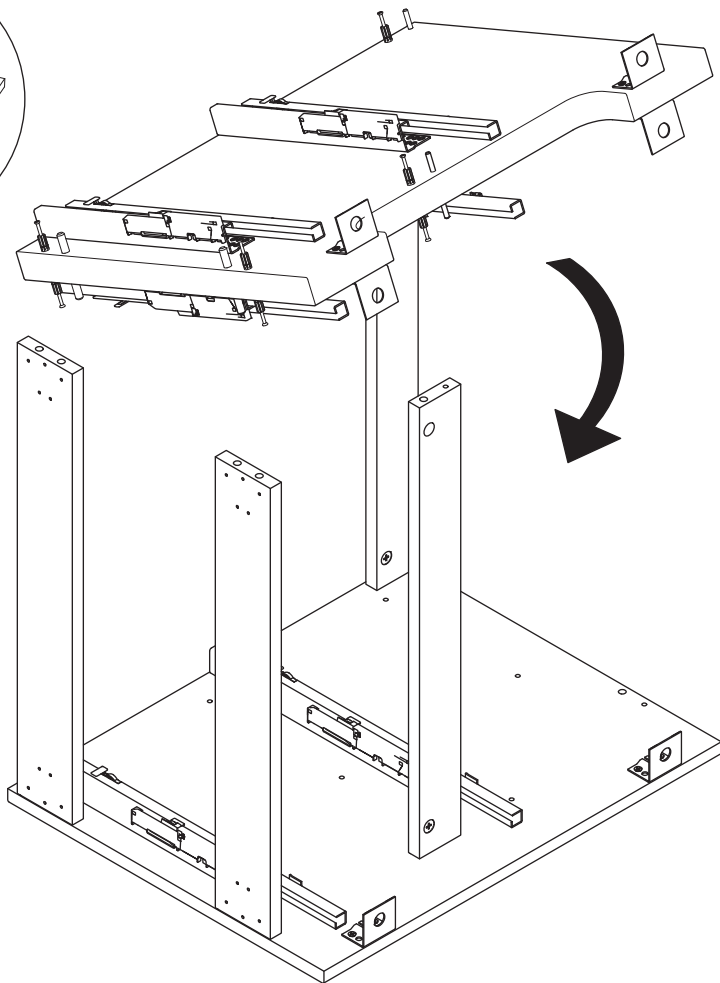
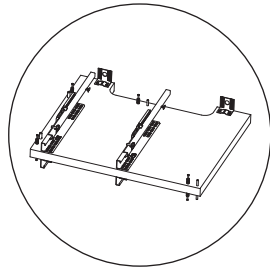
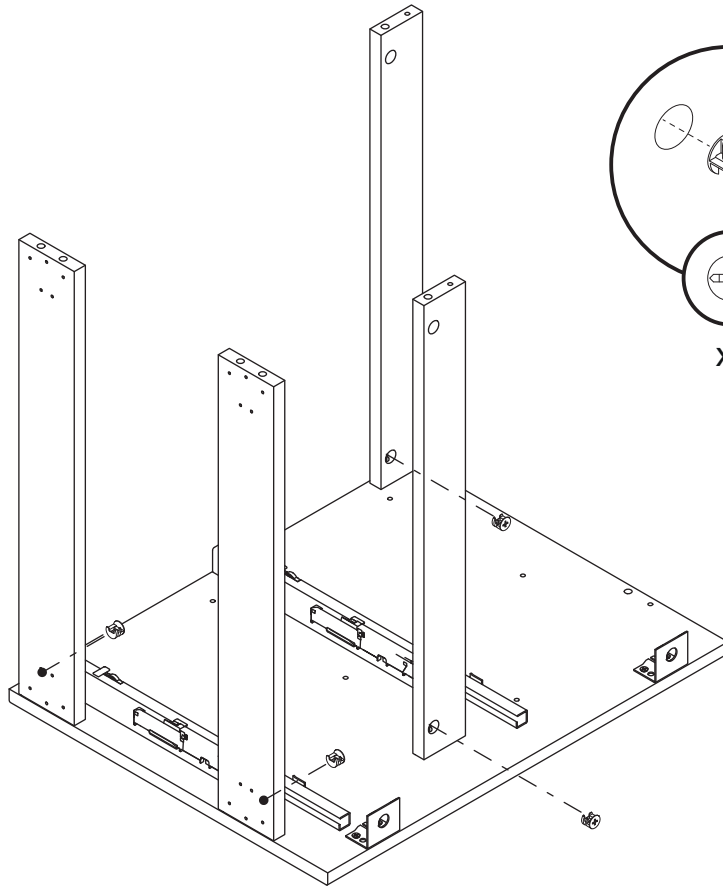
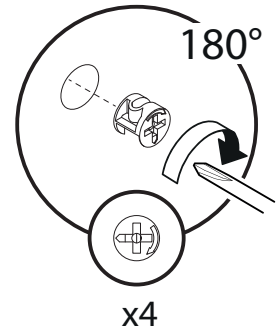
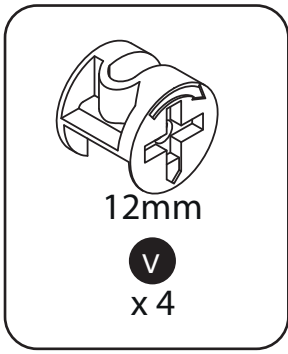

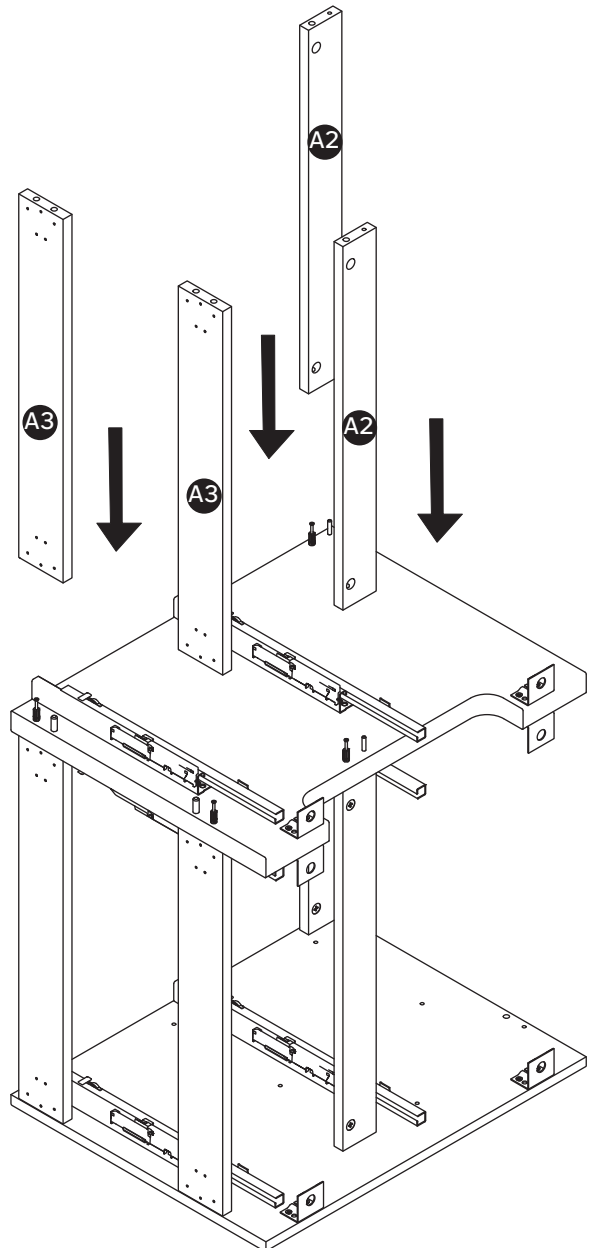
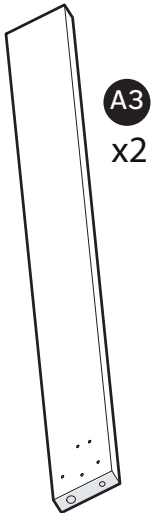
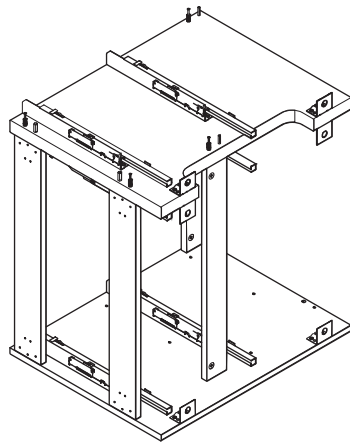
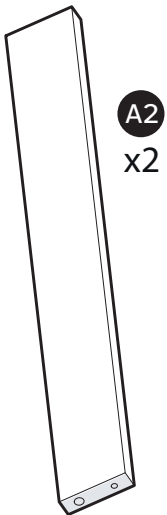
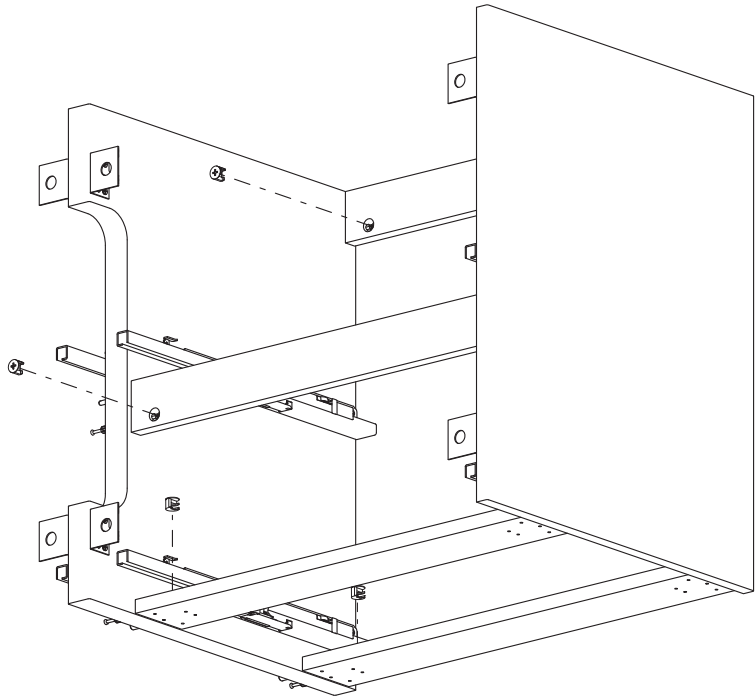
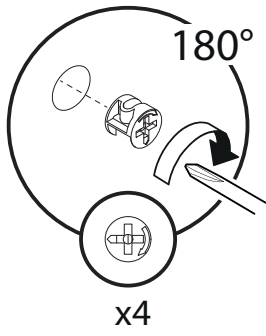
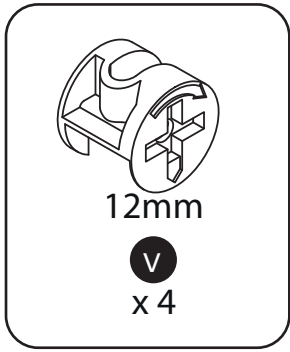

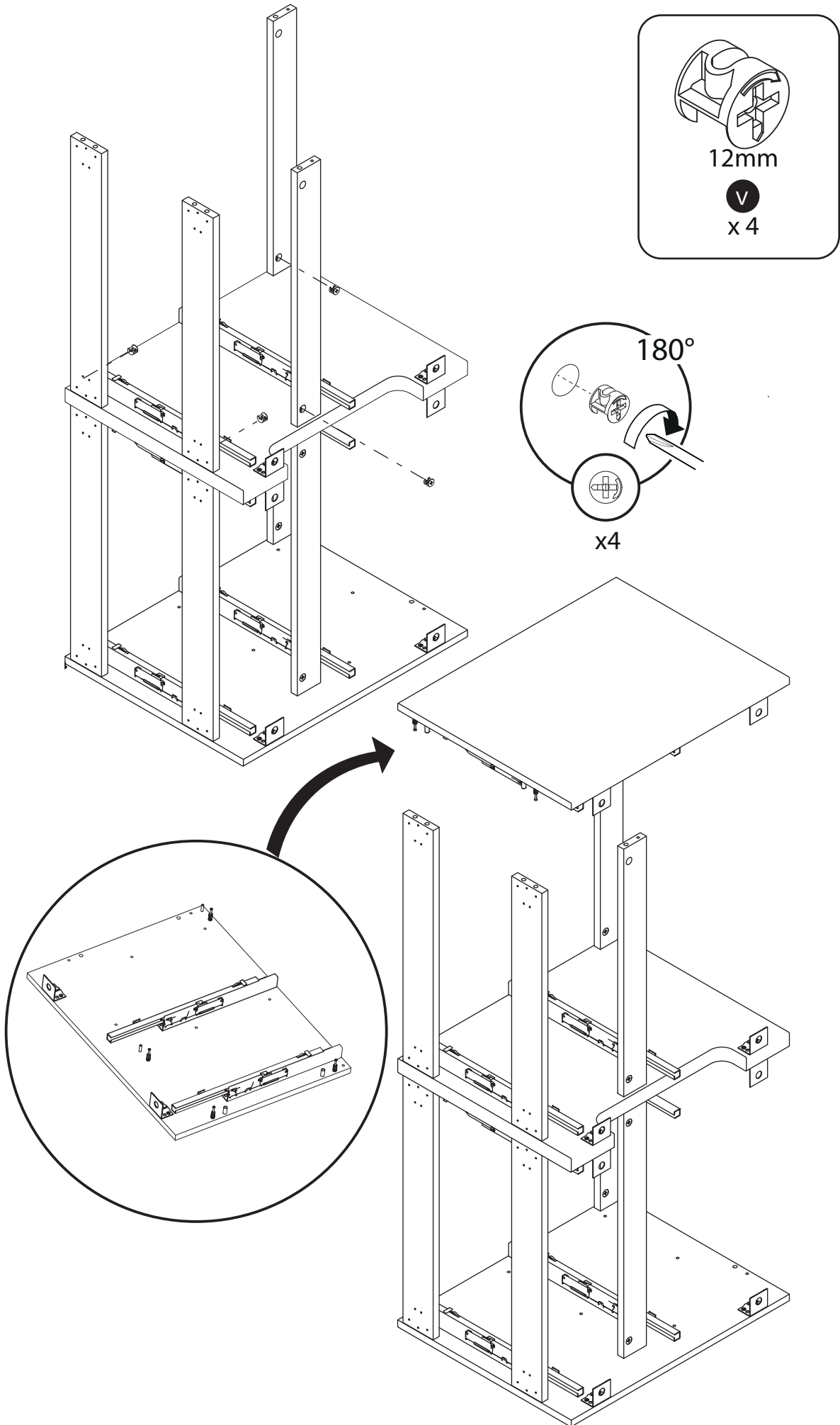

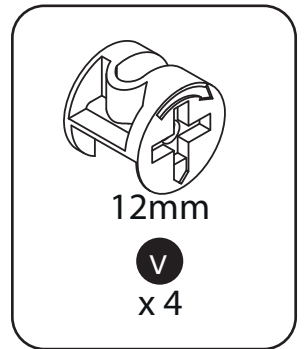
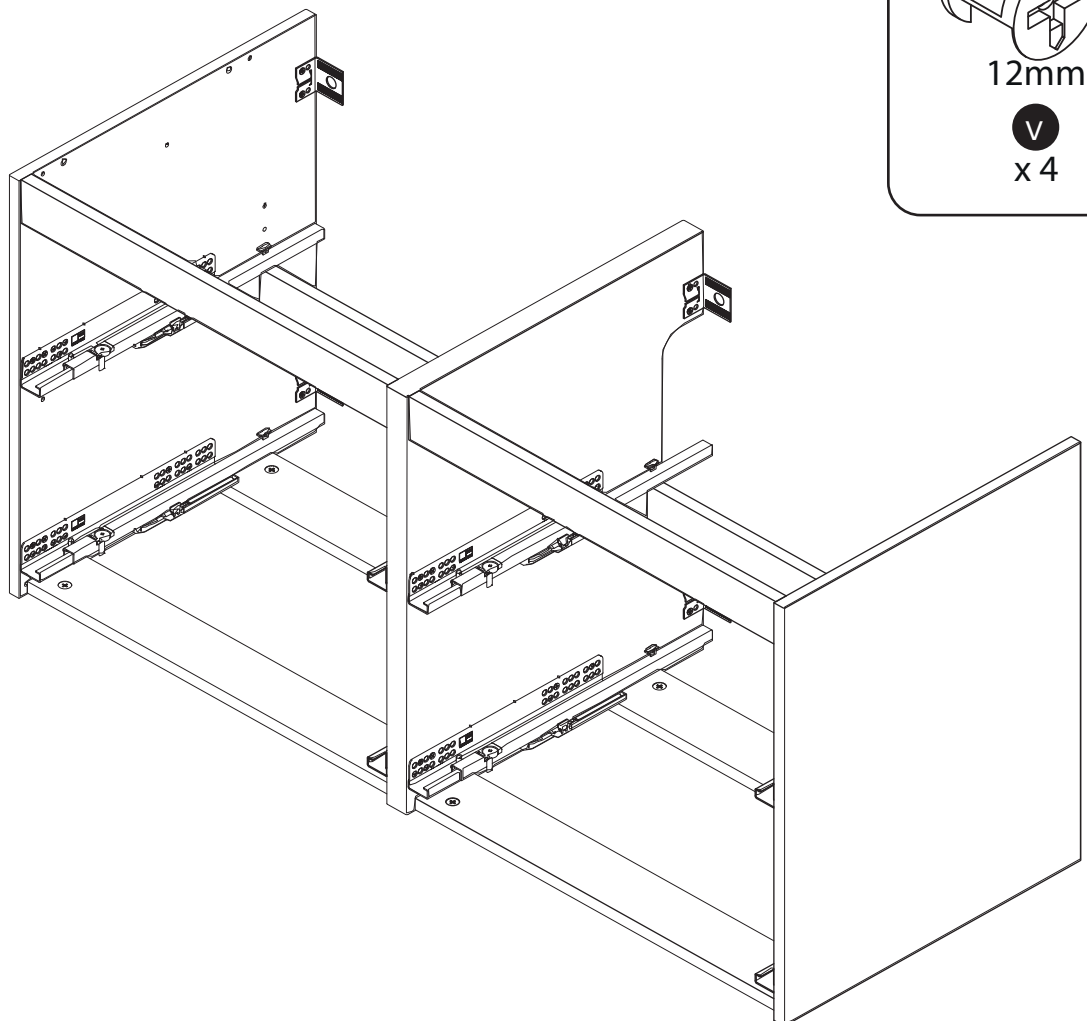
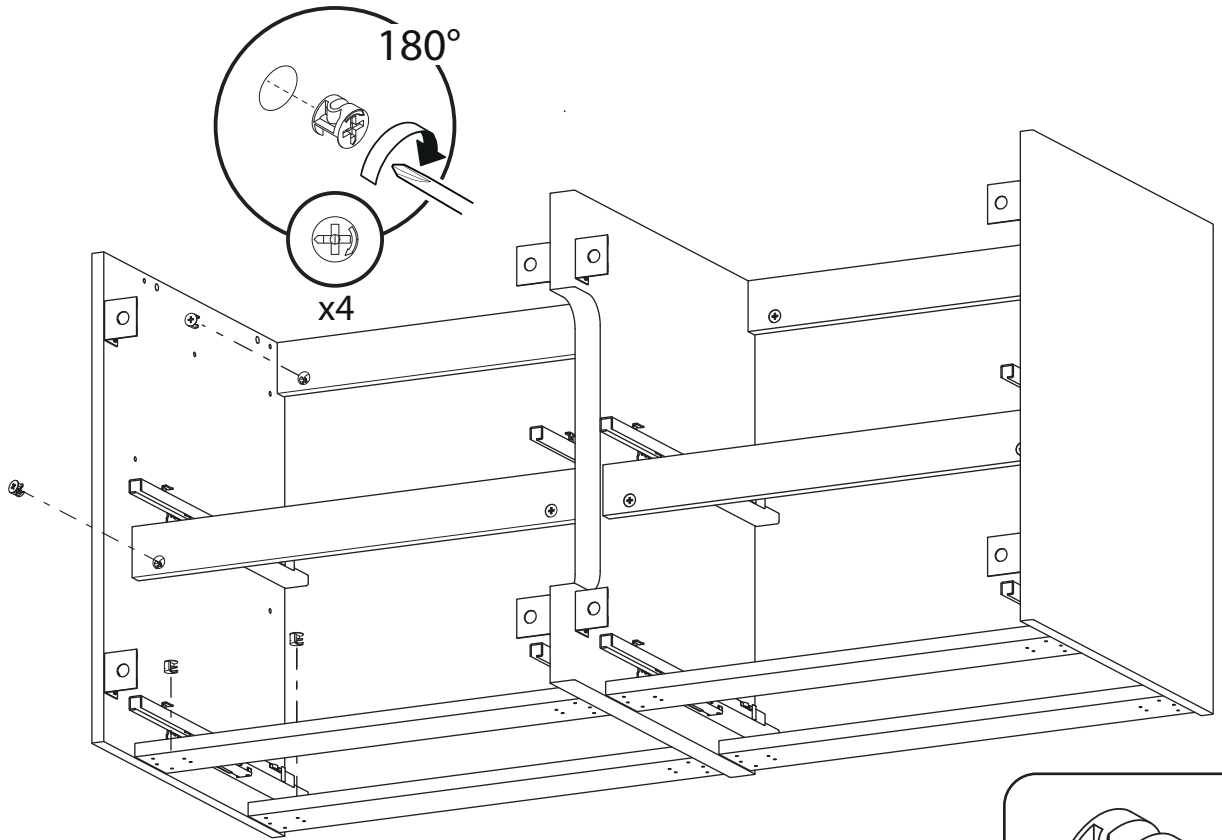

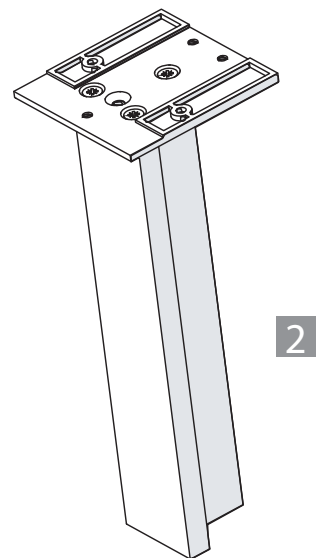
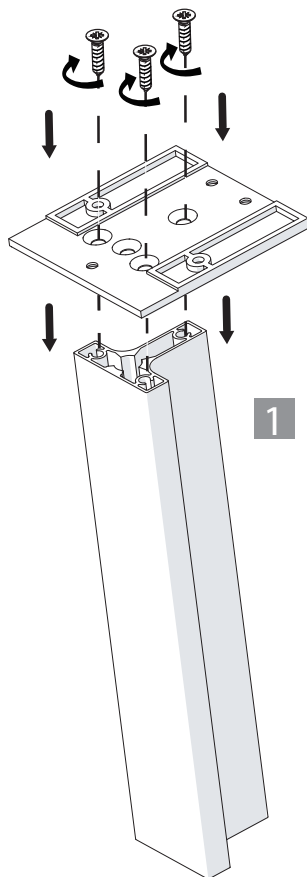

K x2

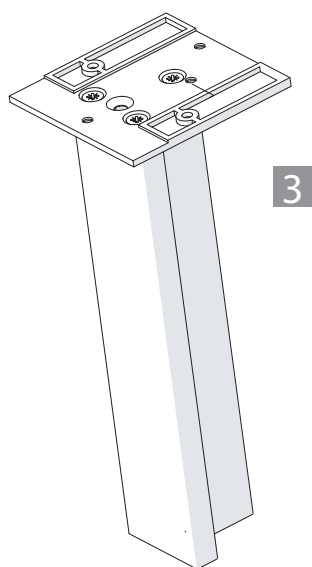

K
x2

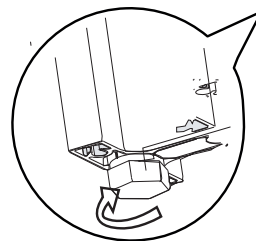
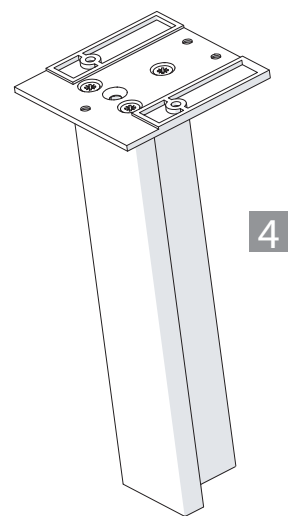
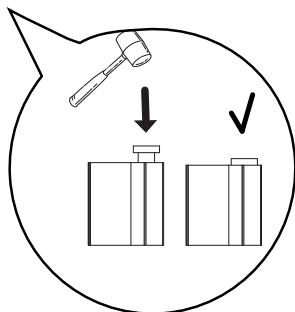
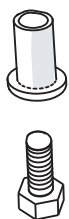

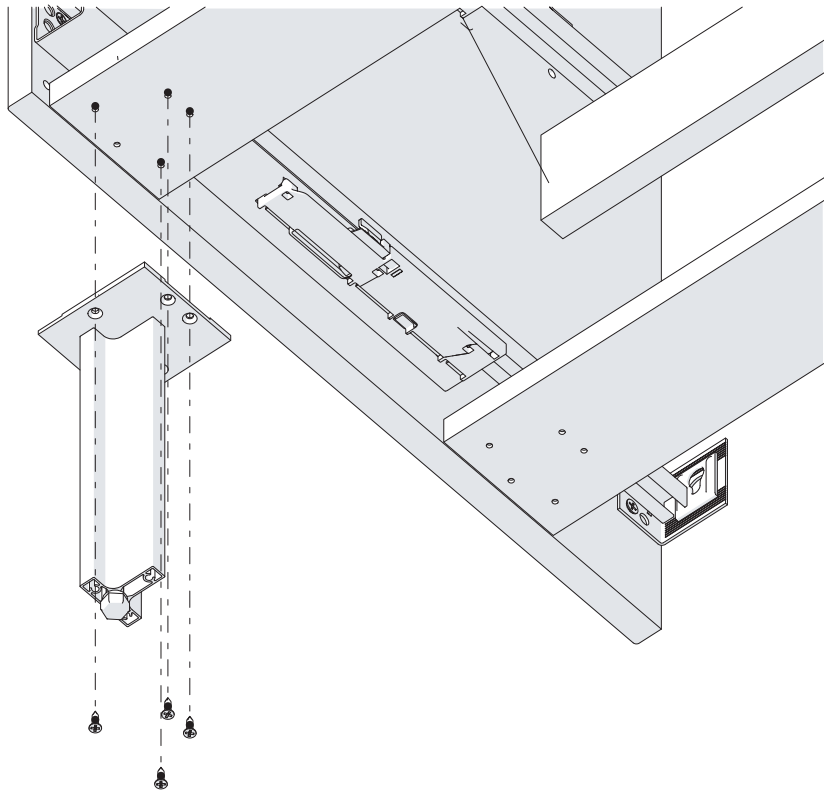

B
x8

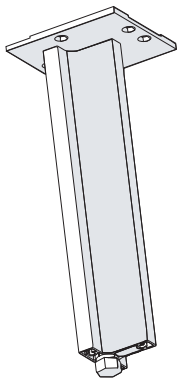
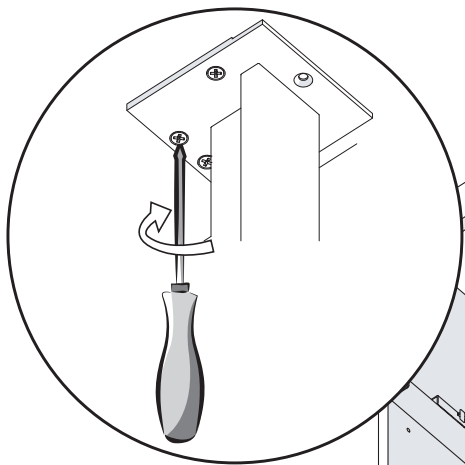

x2

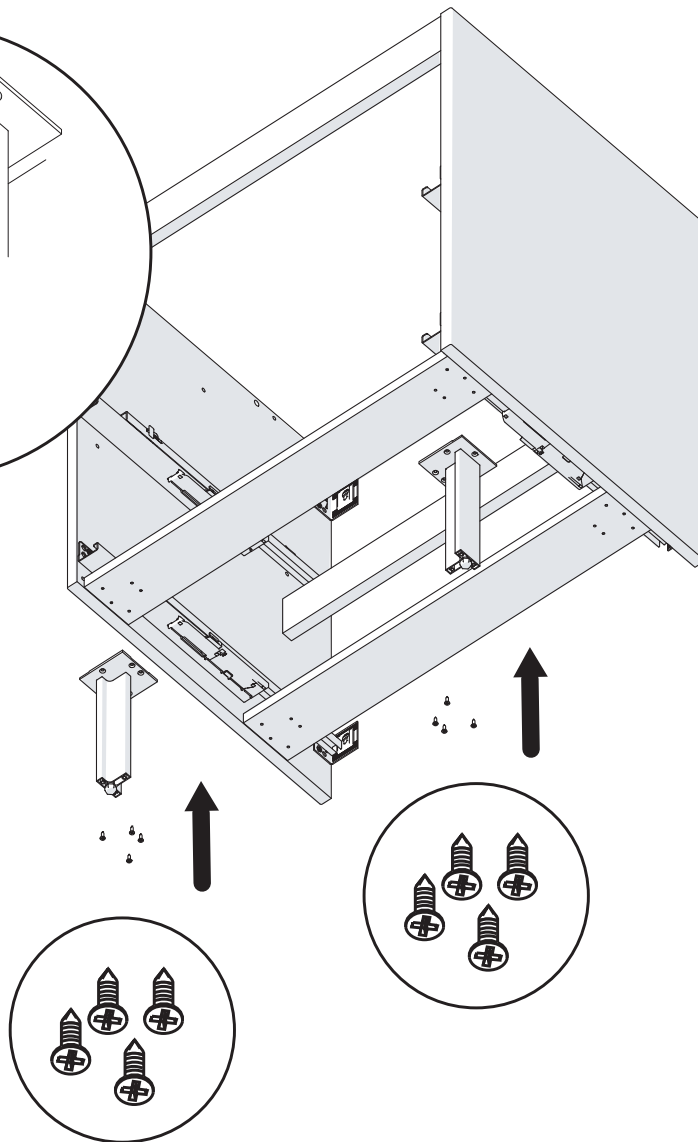

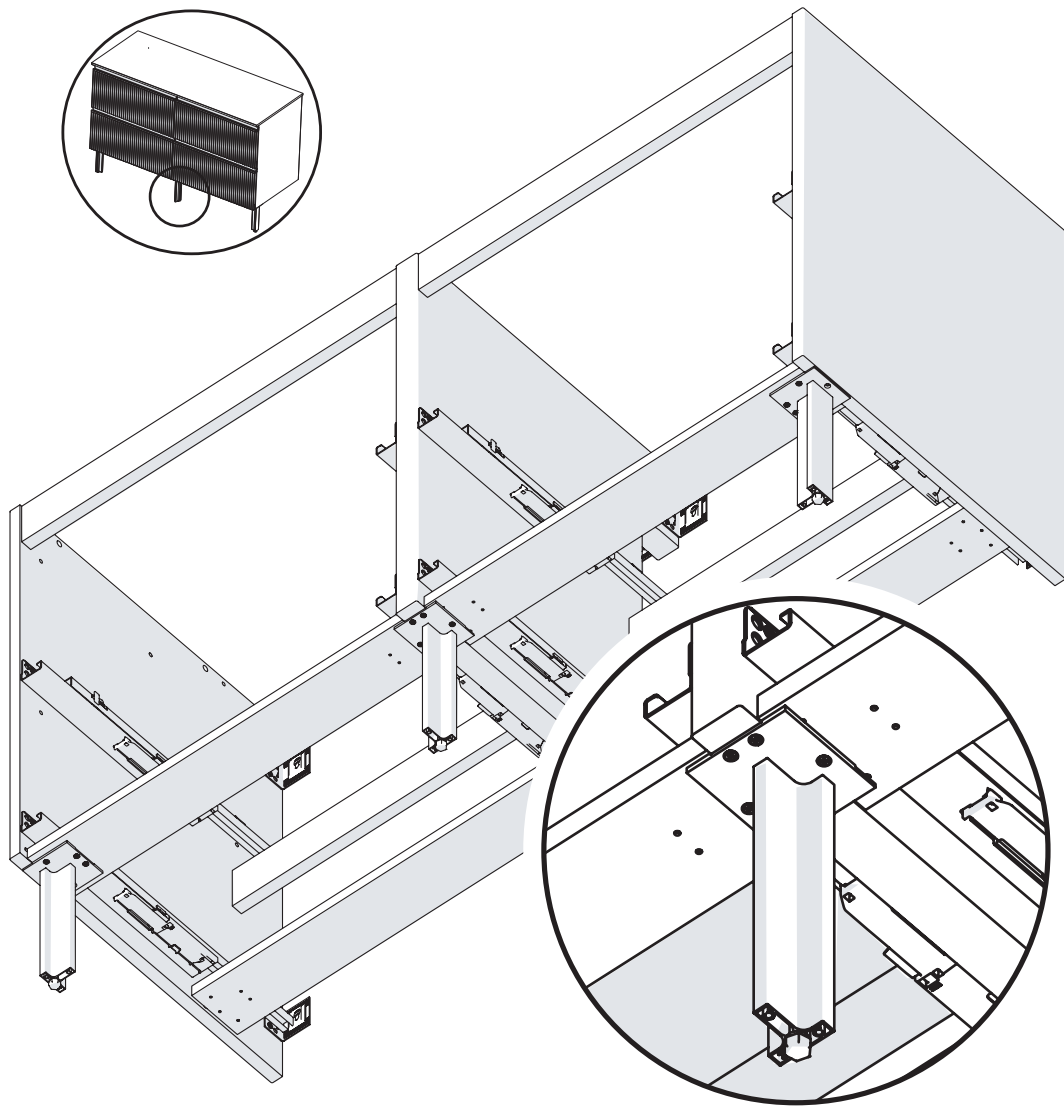

K x1

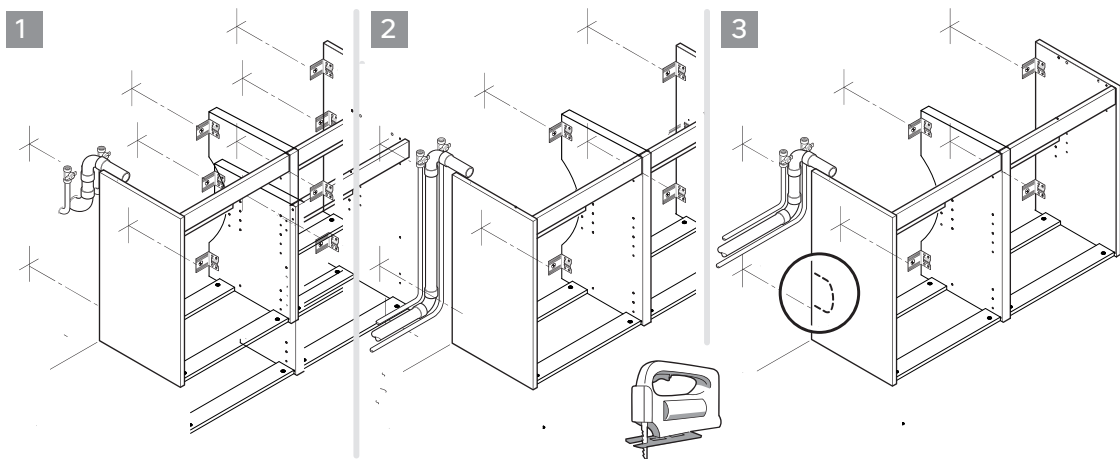

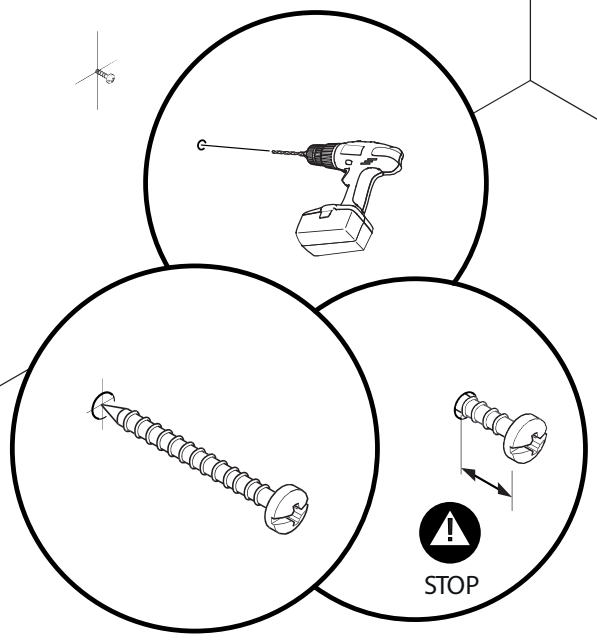
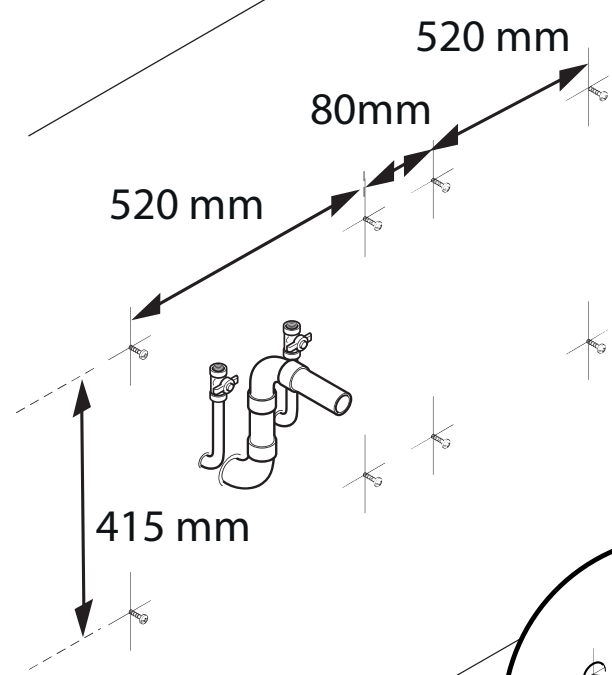
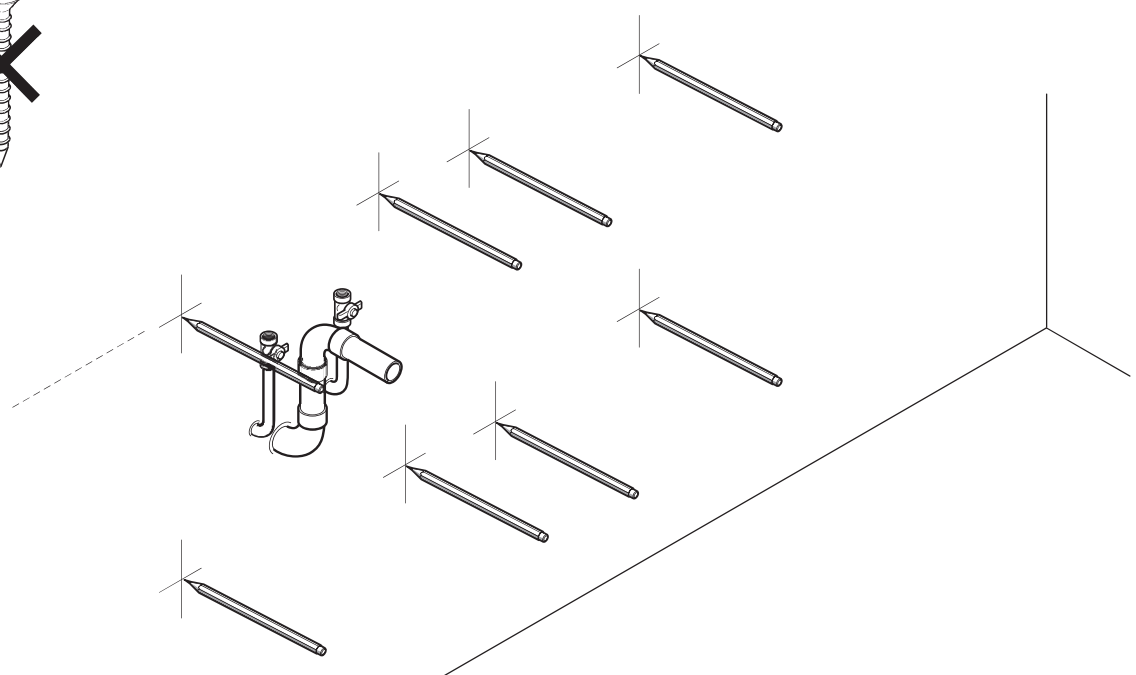
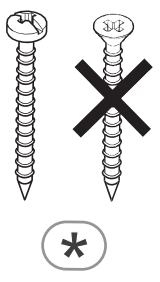

1

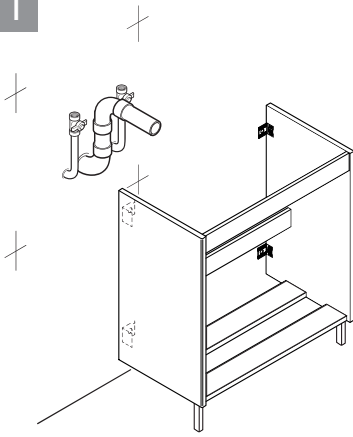

2

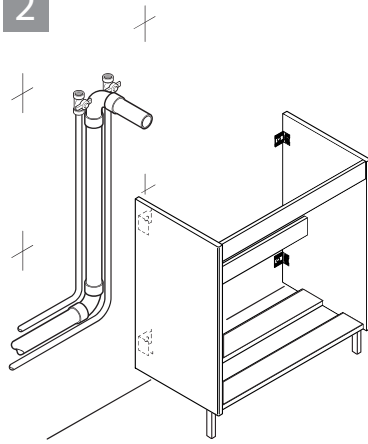

3

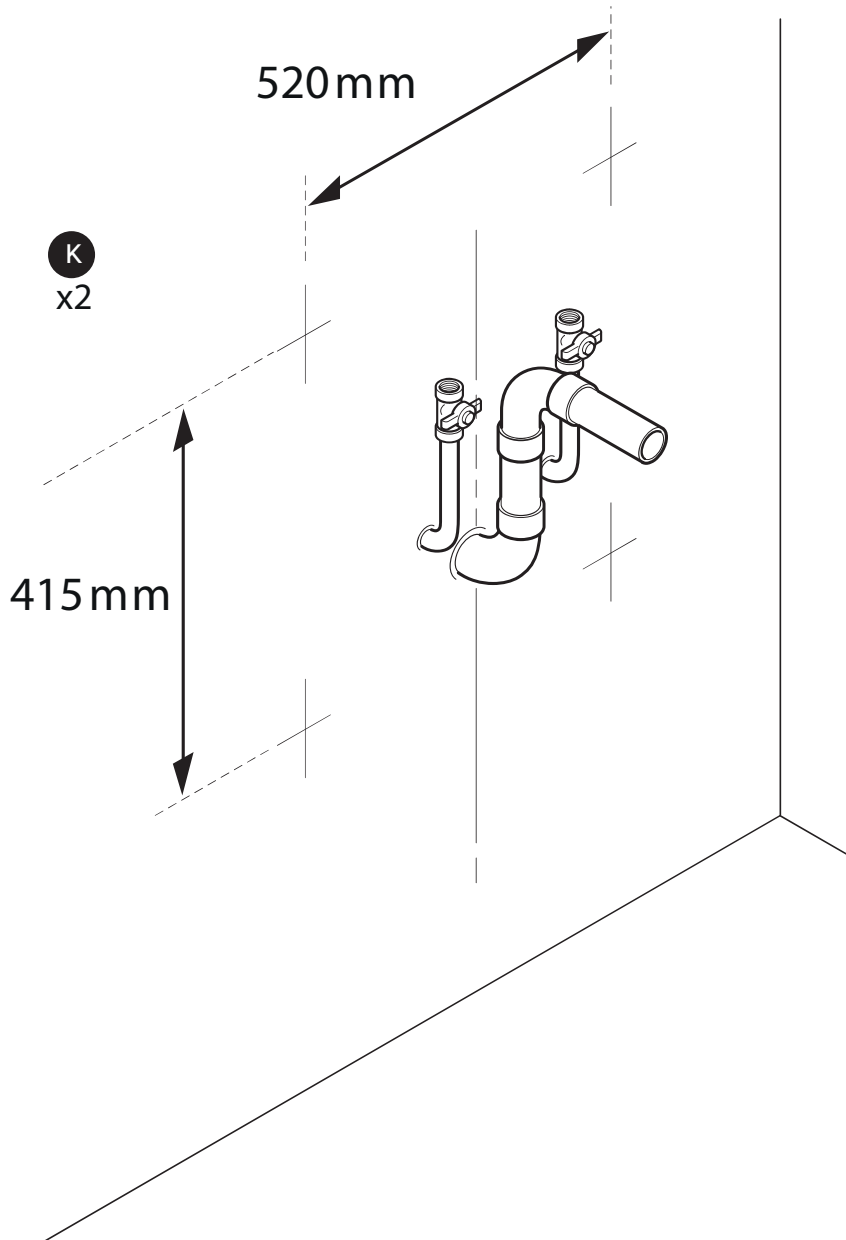
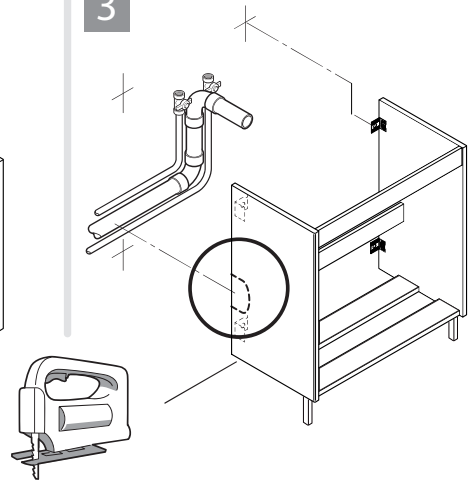

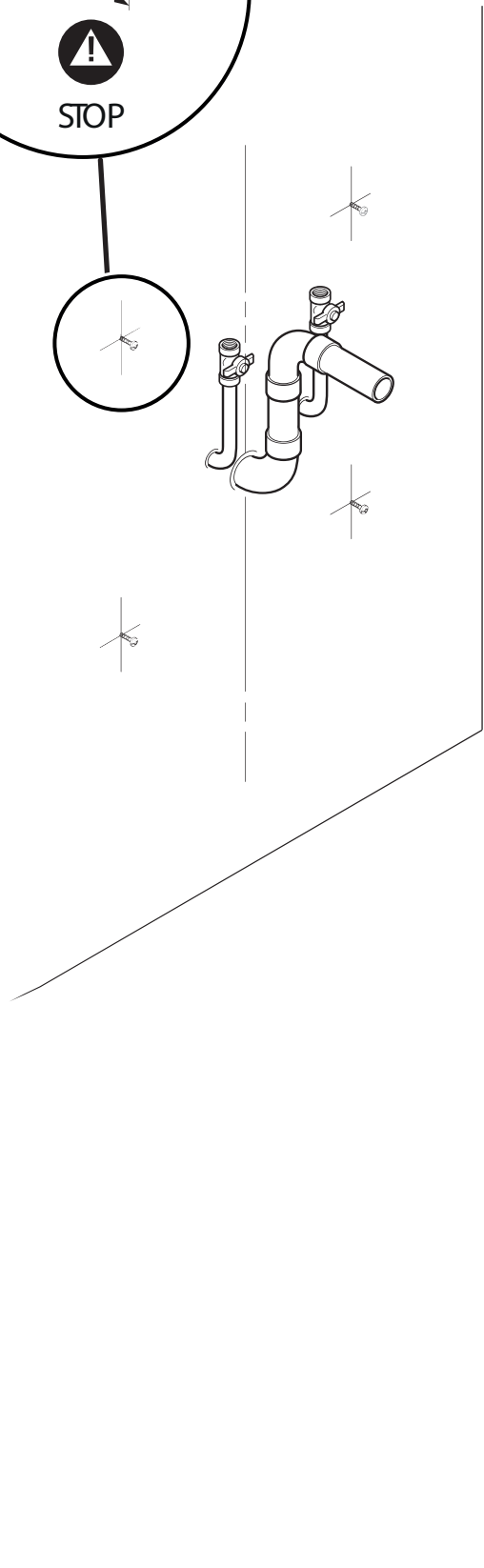
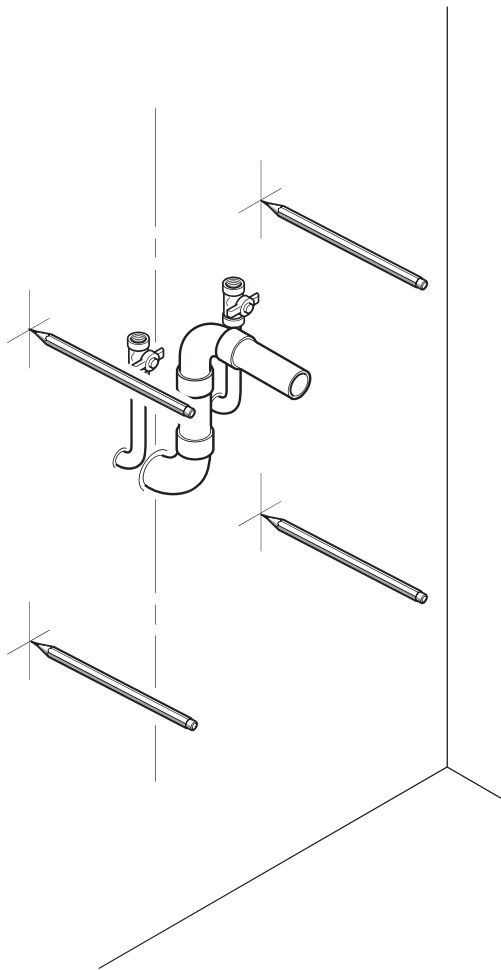
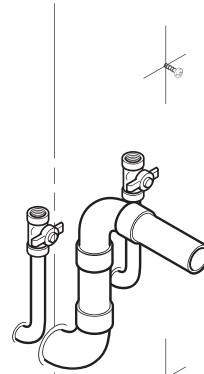
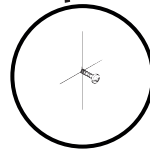
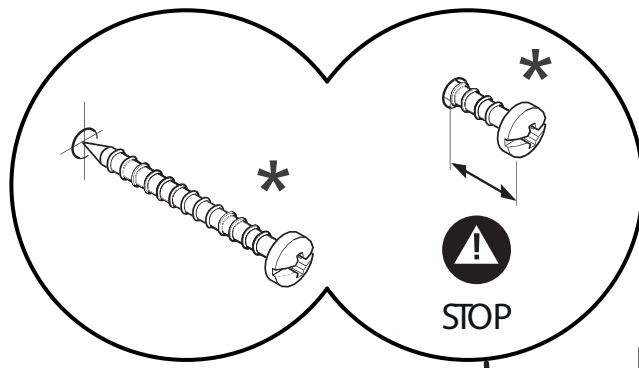
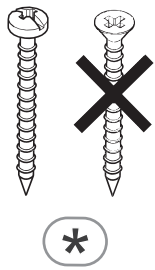

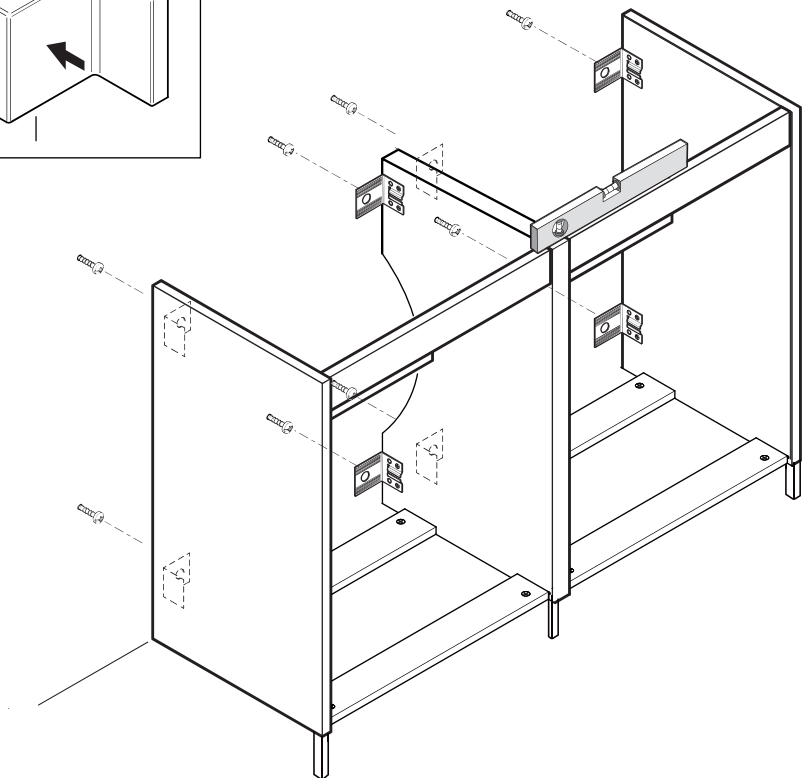
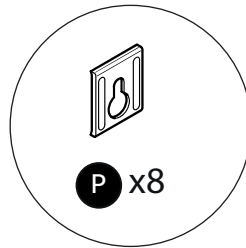
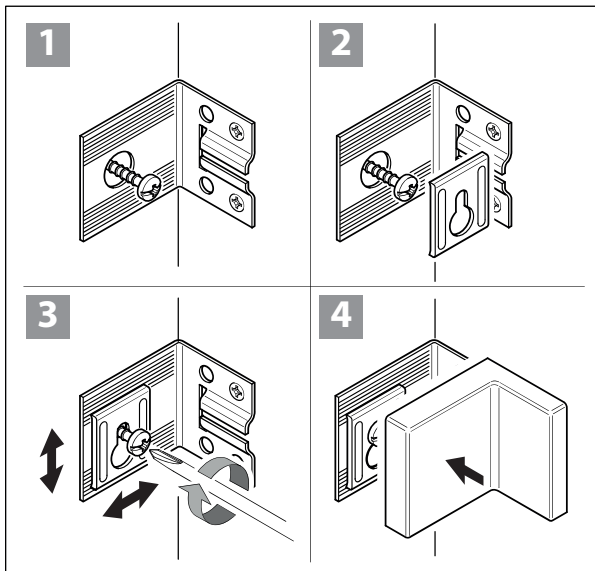
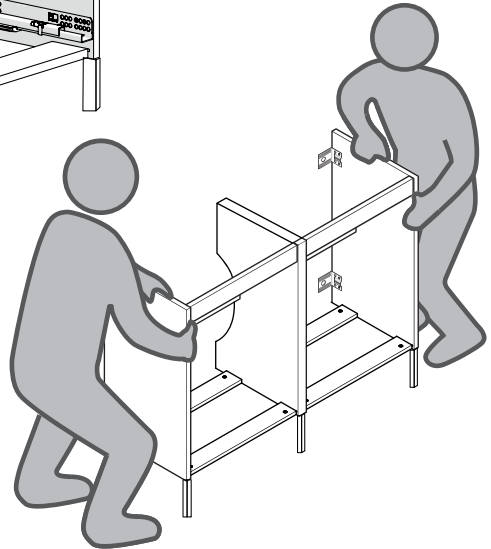
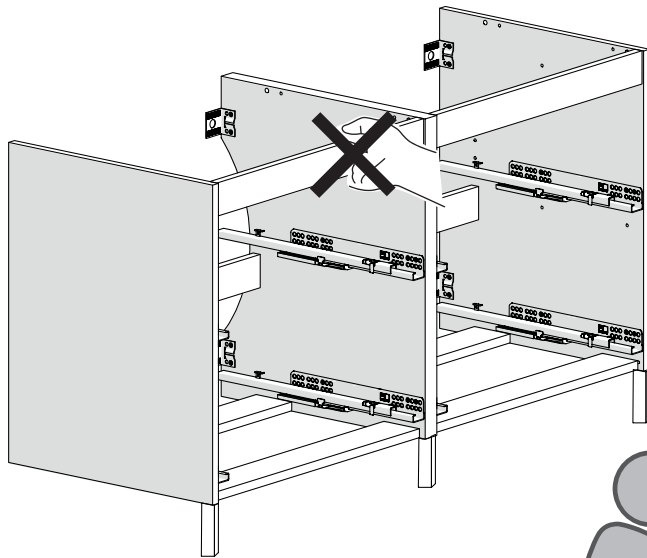

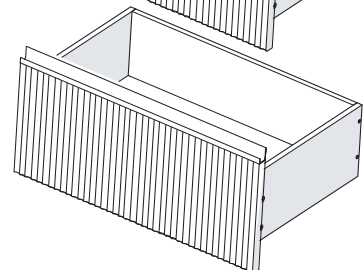
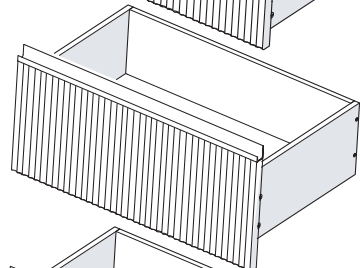
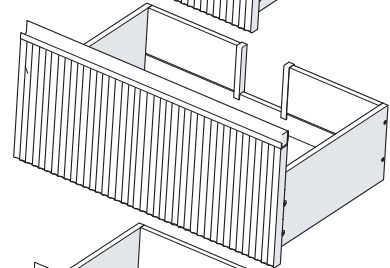
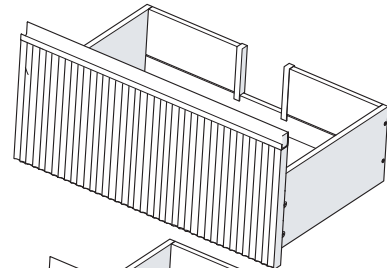
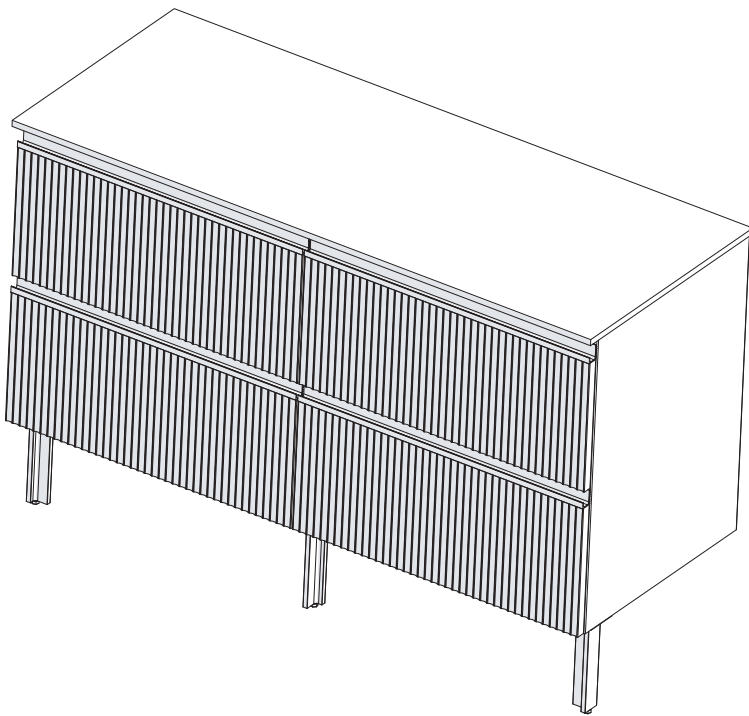
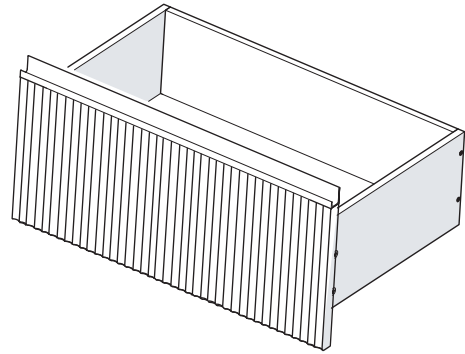
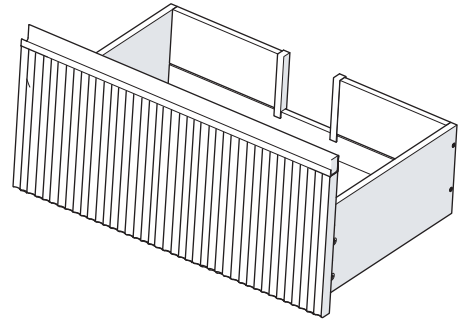
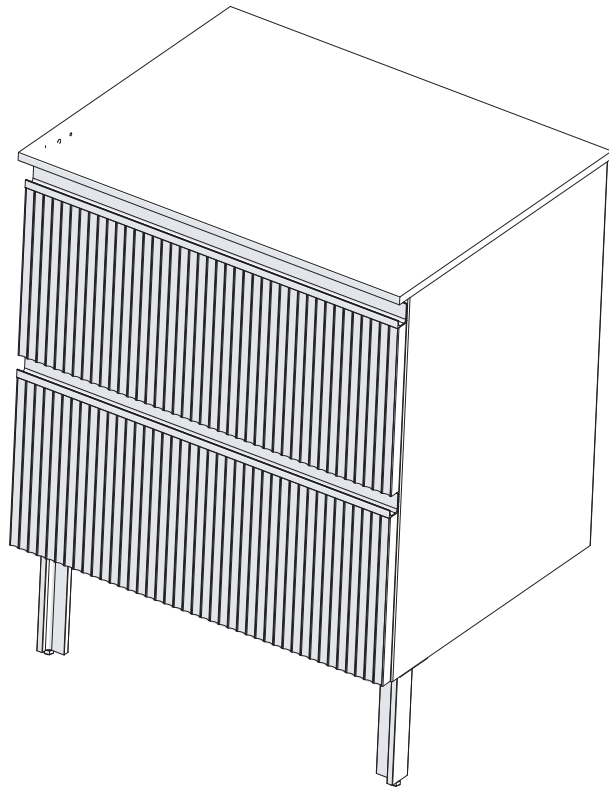

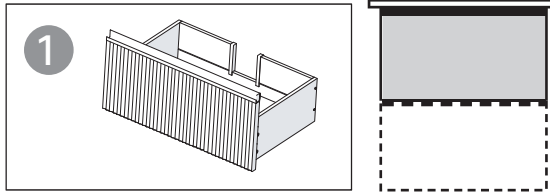

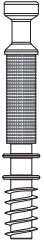

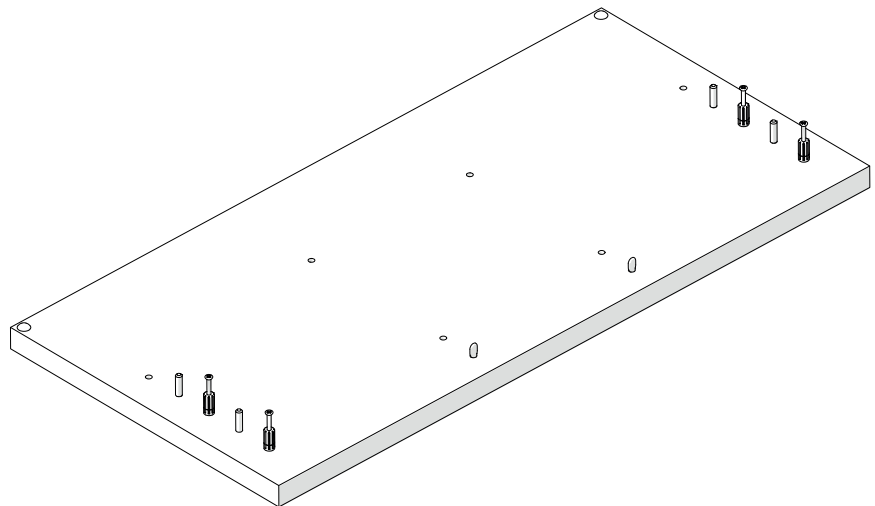
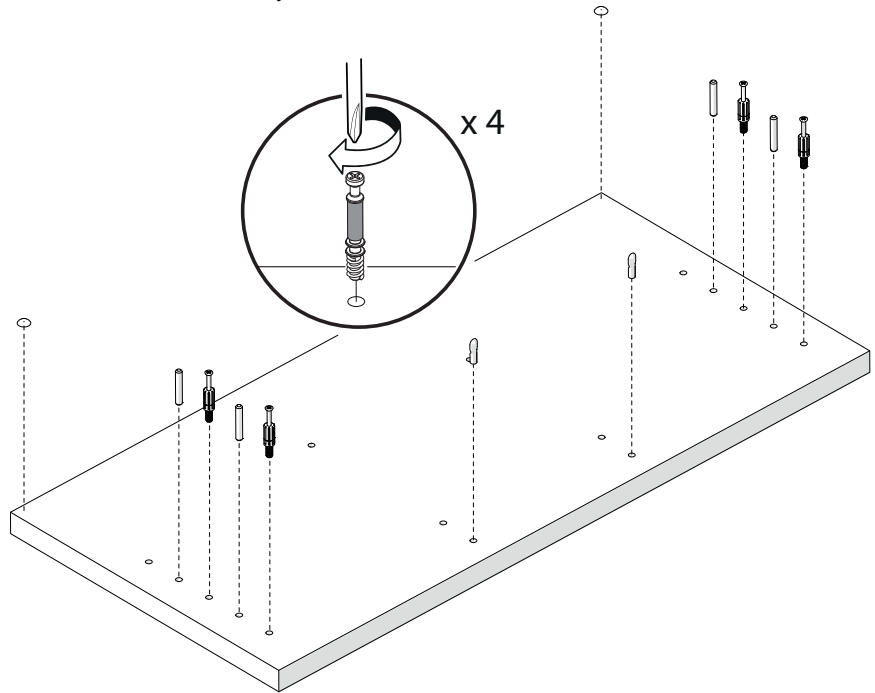
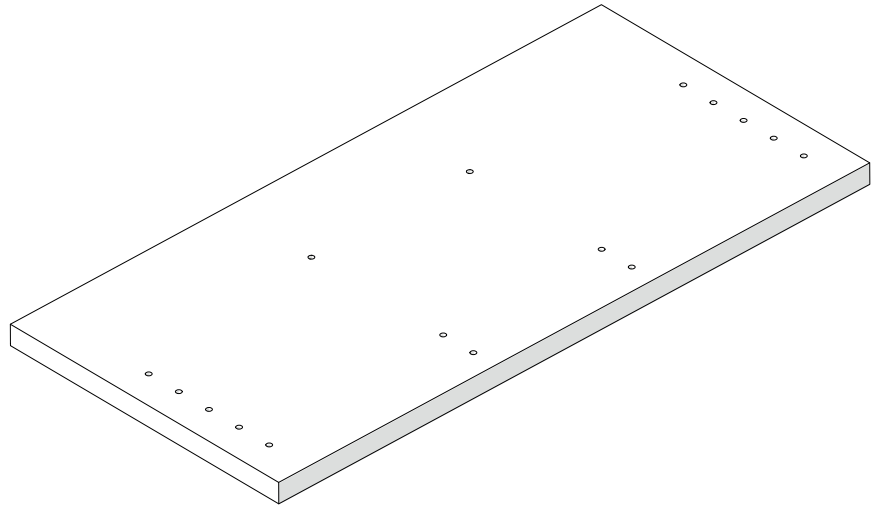

- 

Z
x4
- 
(Ø5)
X
x4
- 
M
x2
- 
N
x2



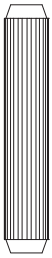

E
x2



(Ø8)

Y
x2

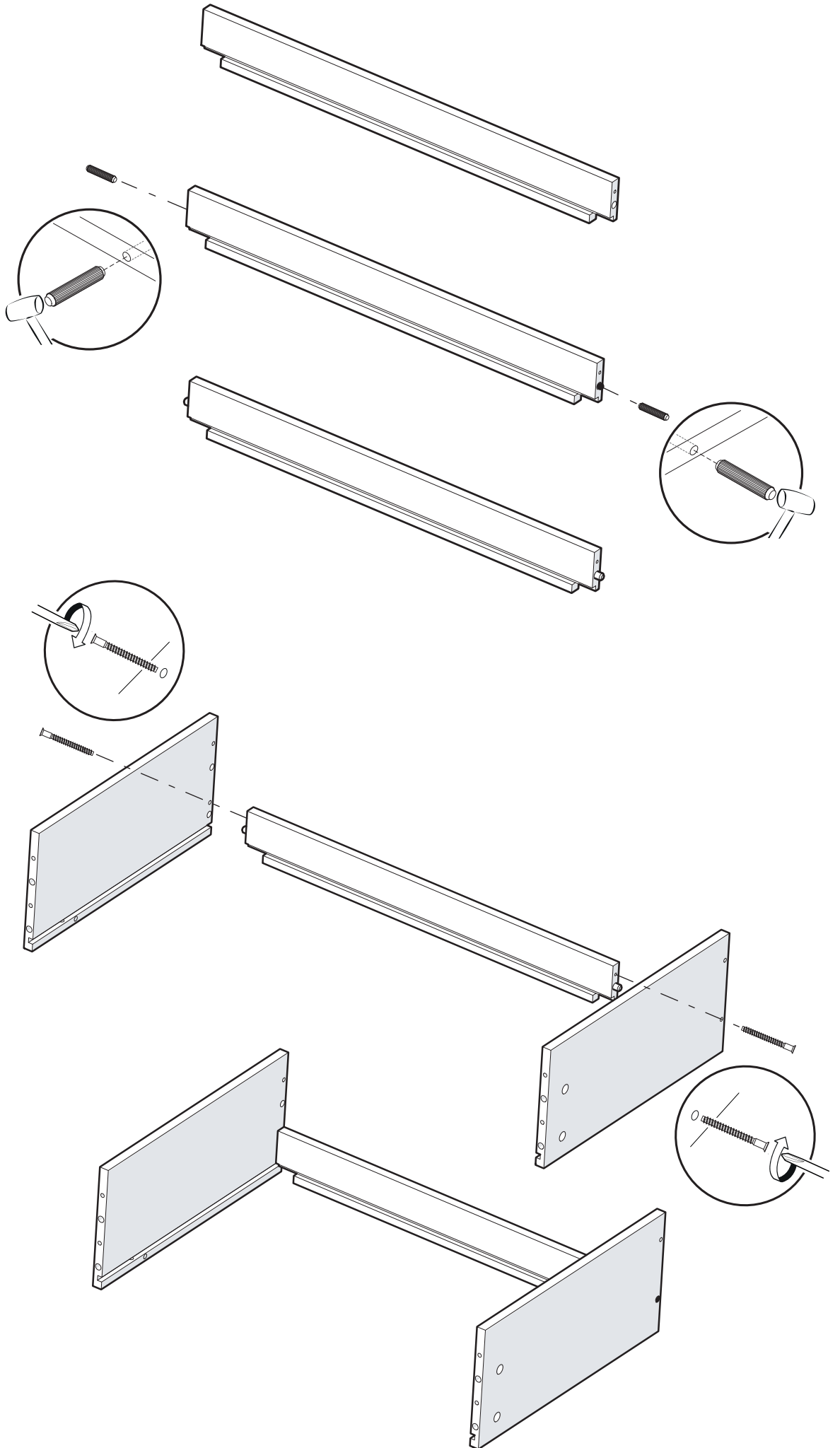

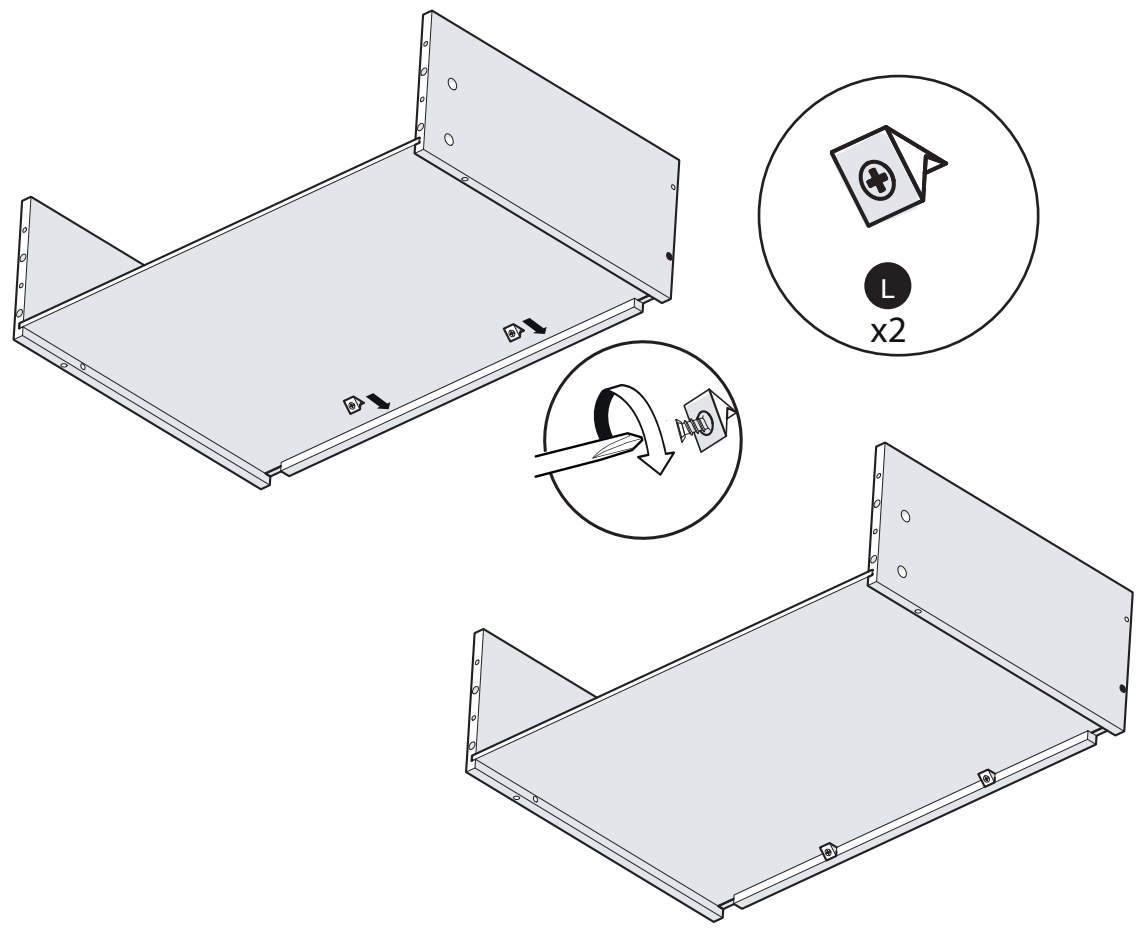
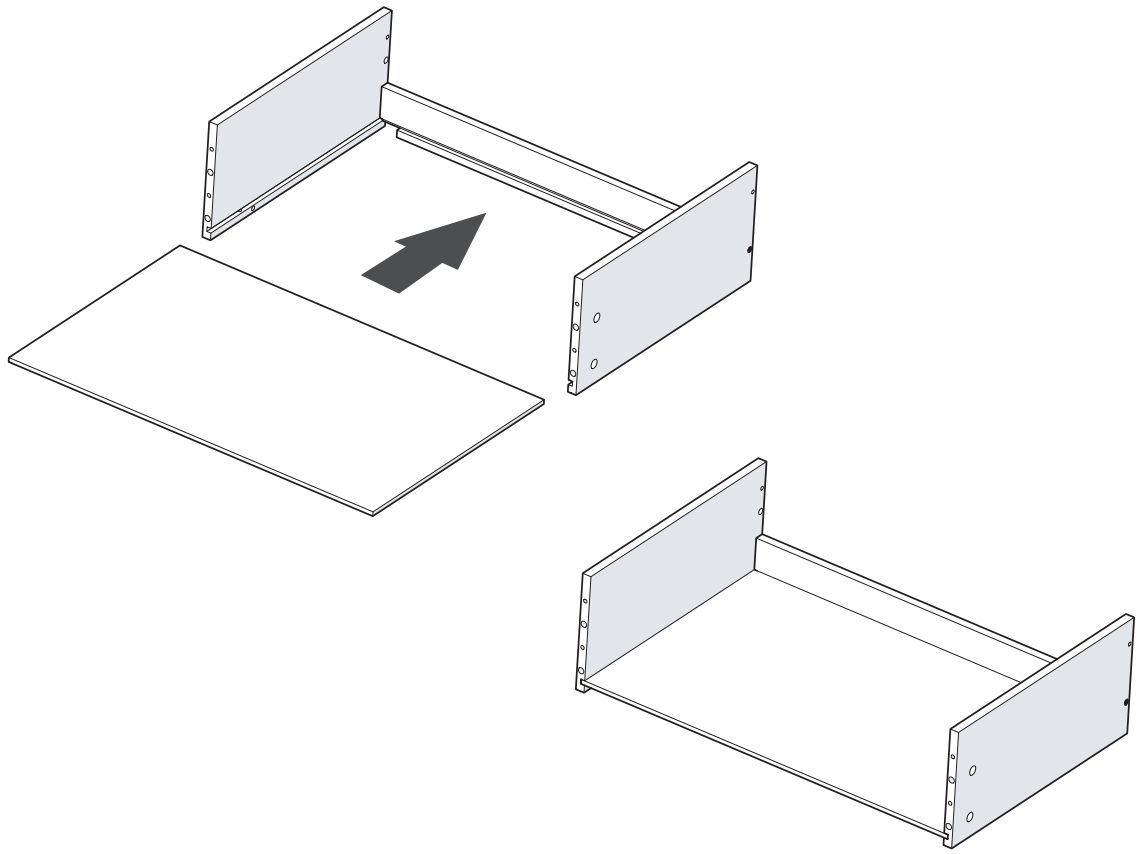

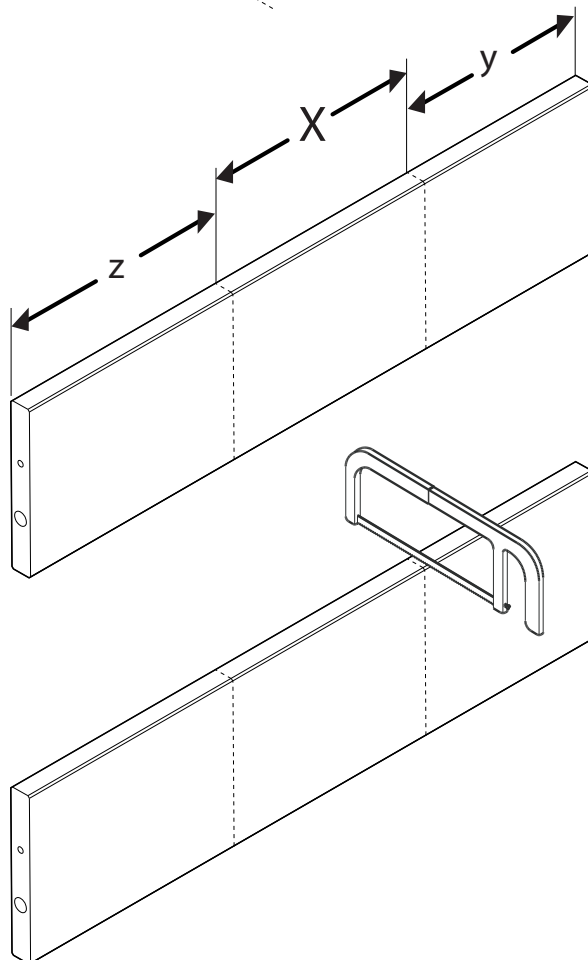
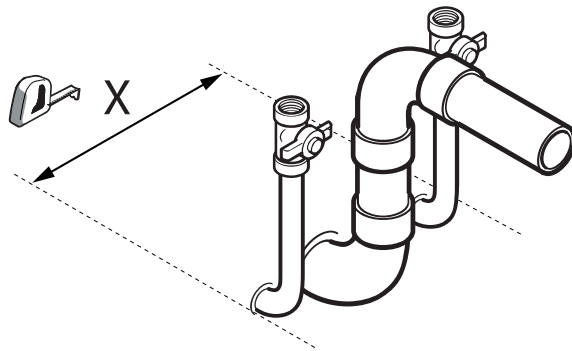
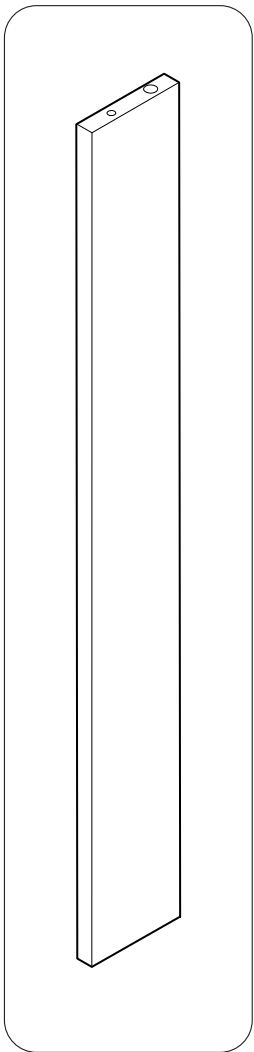
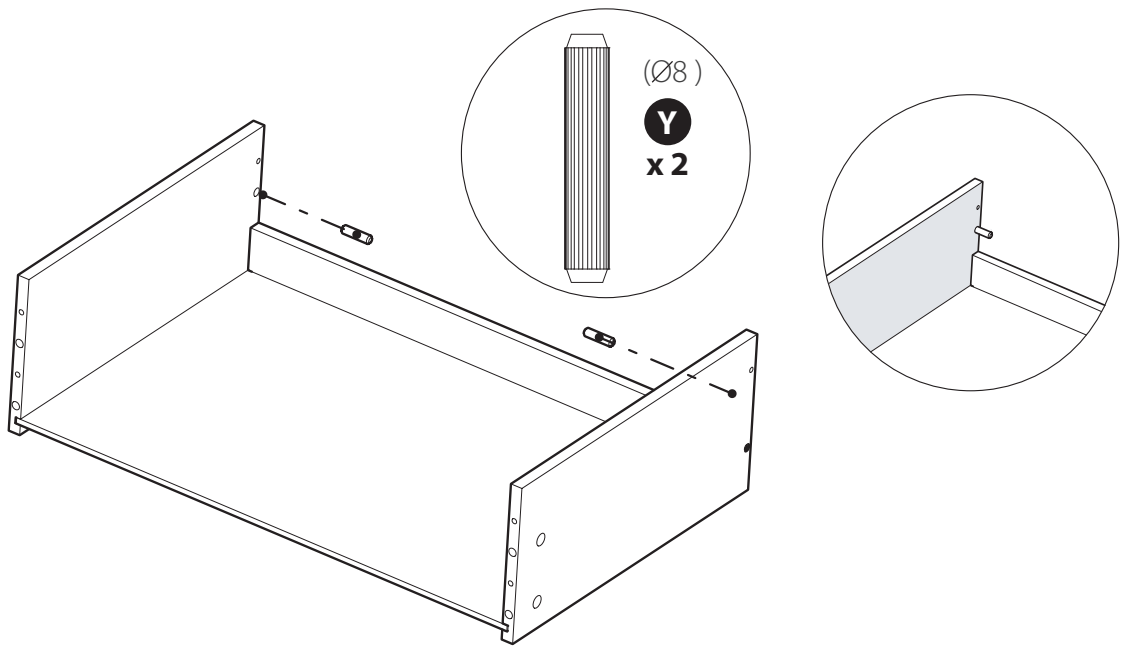

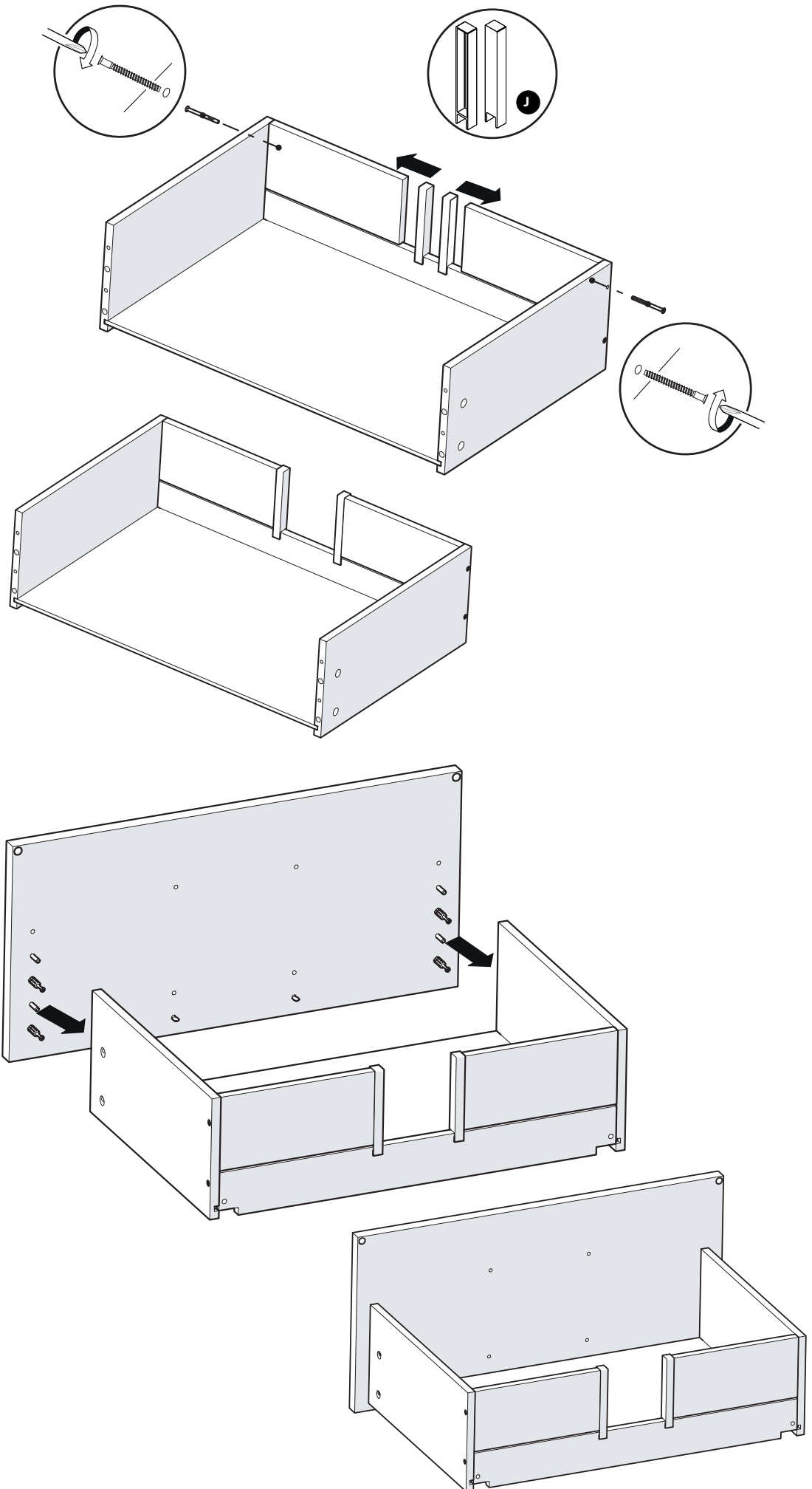
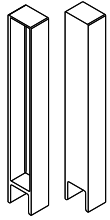
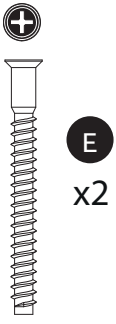

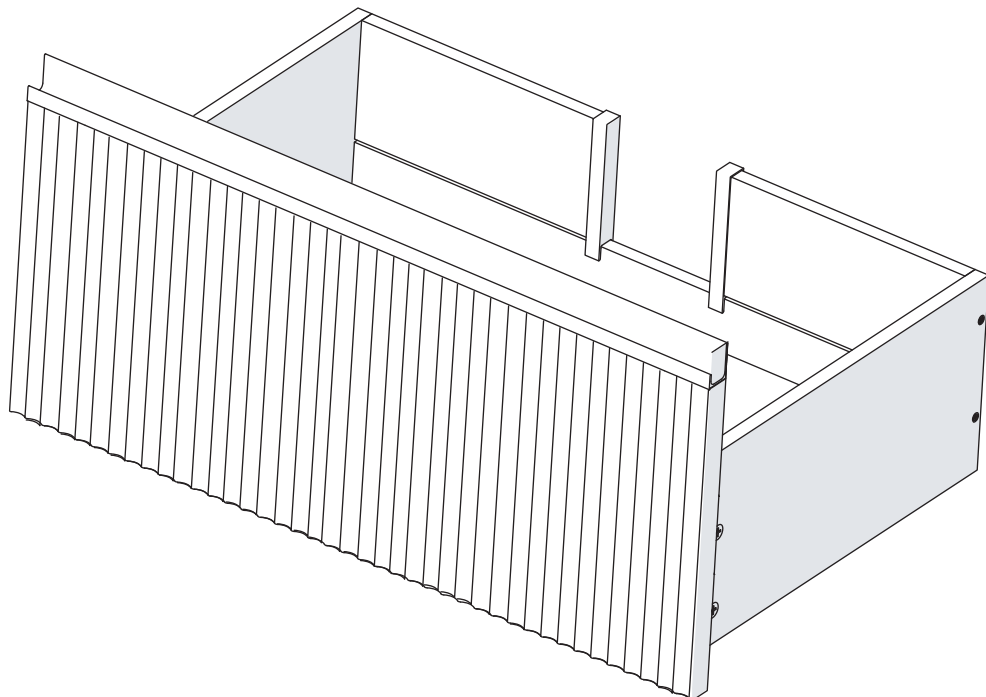
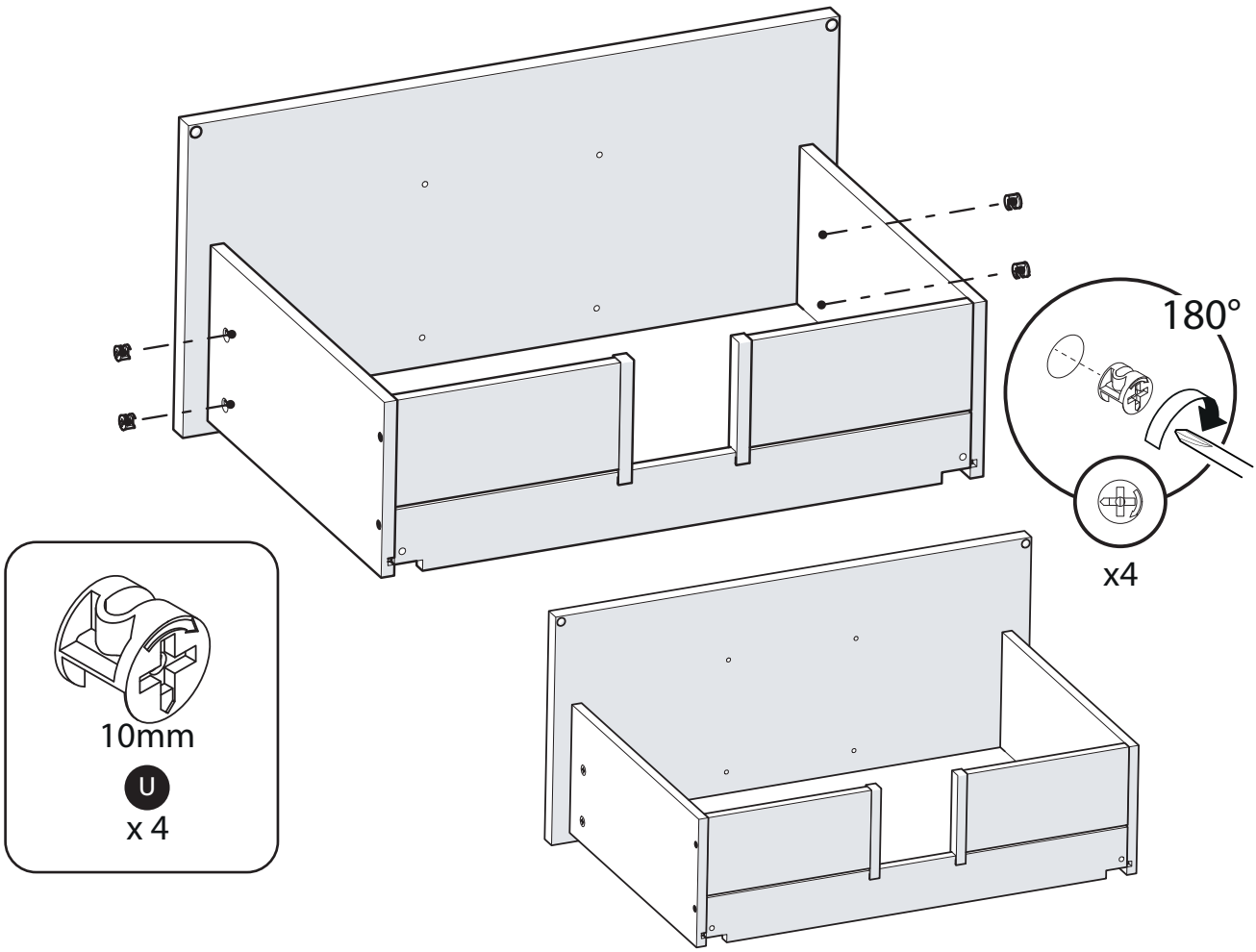

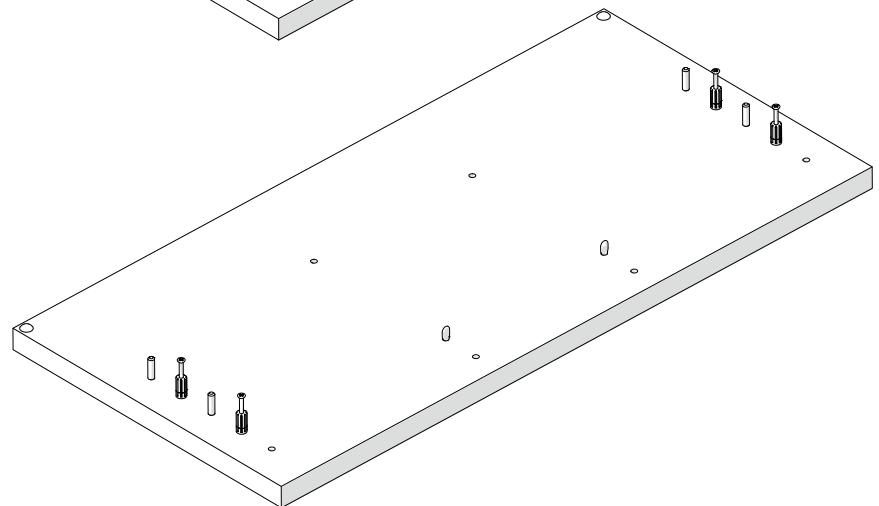
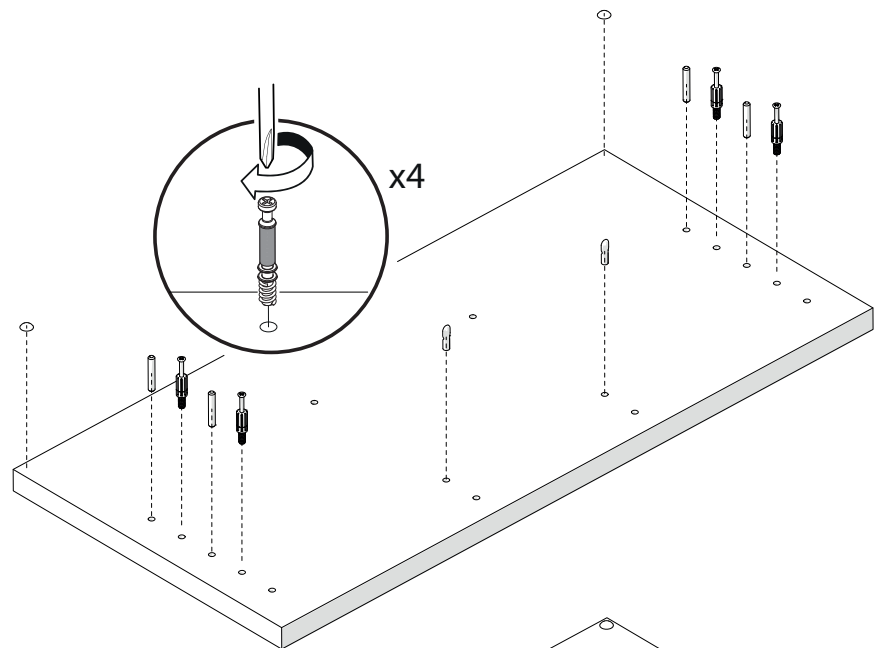
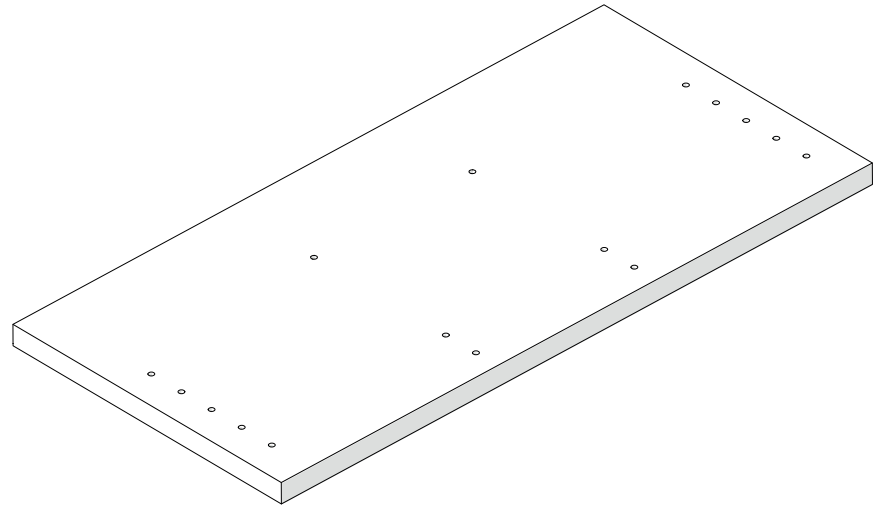
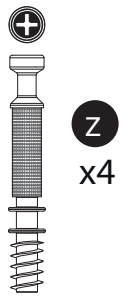
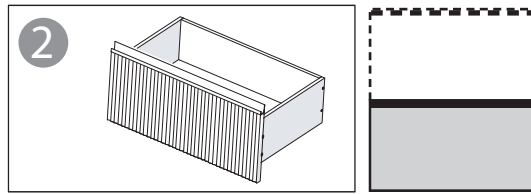



E
x4

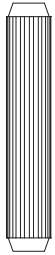

(O8)
Y
x4

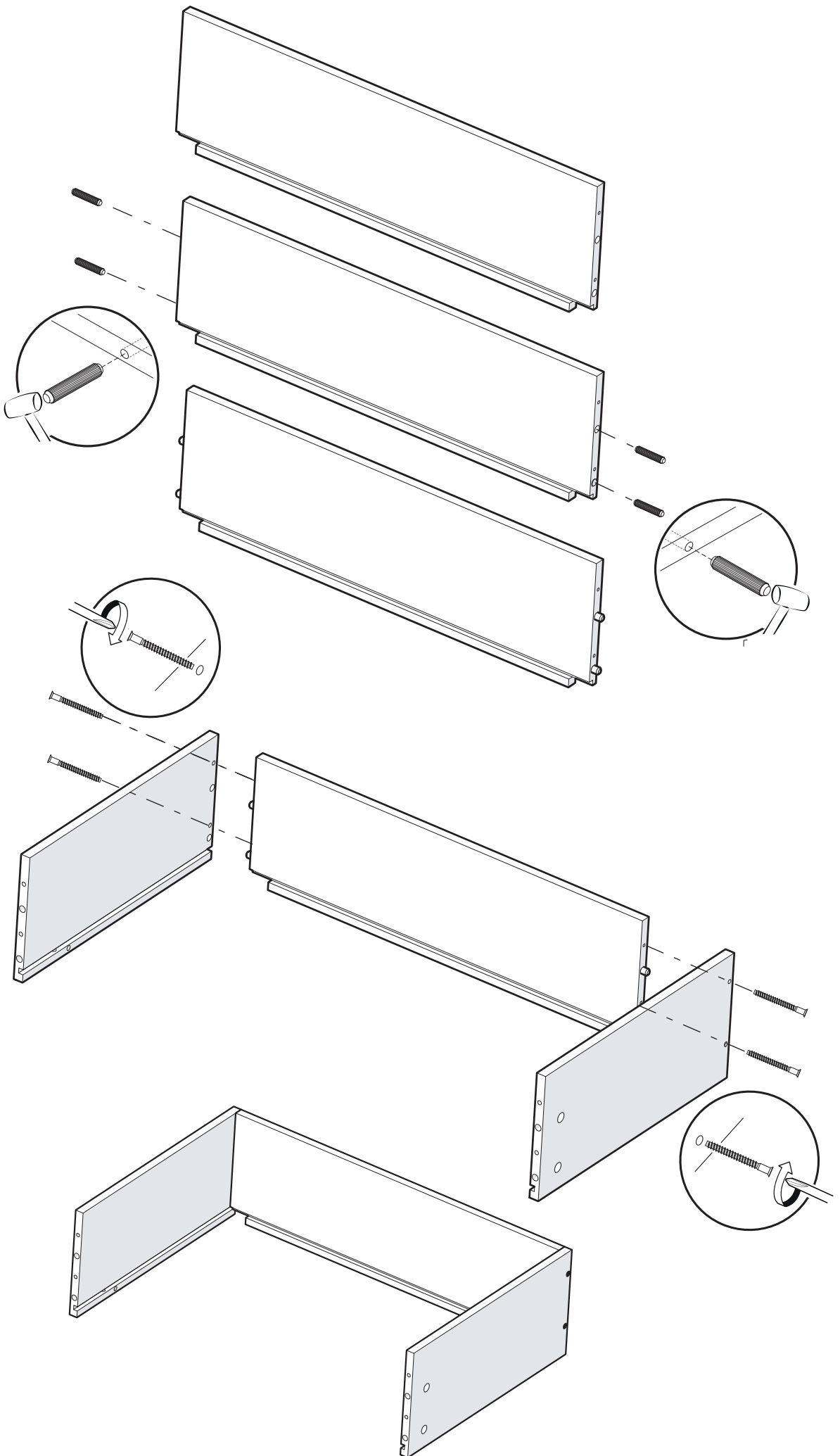

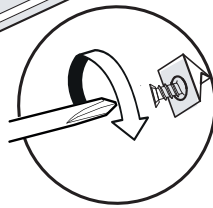
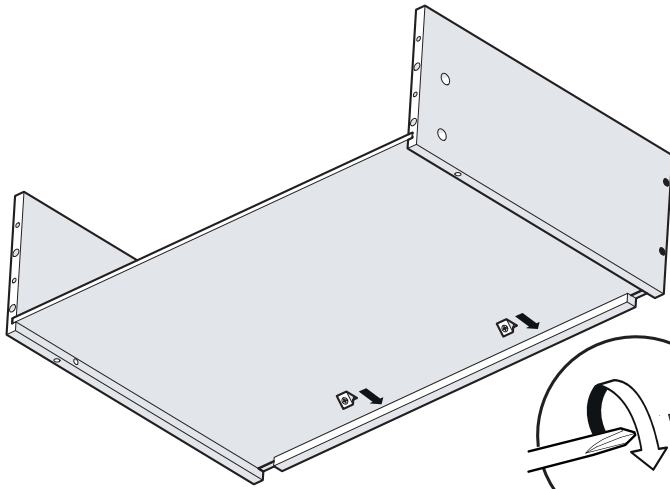
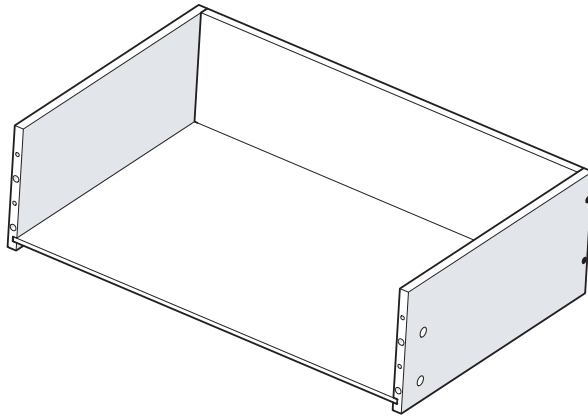
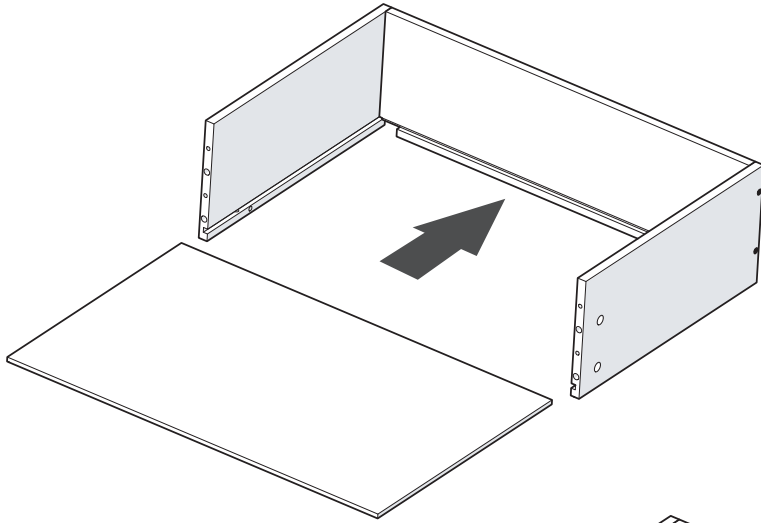

L
x2

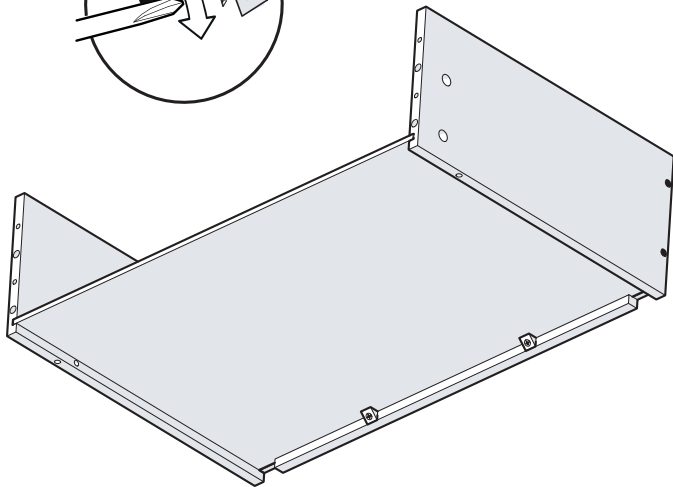

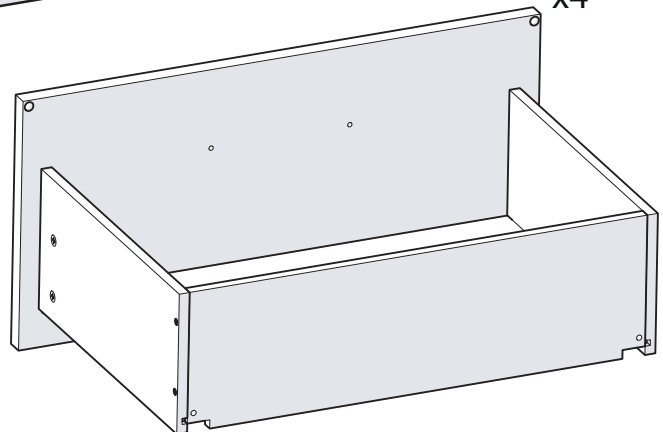
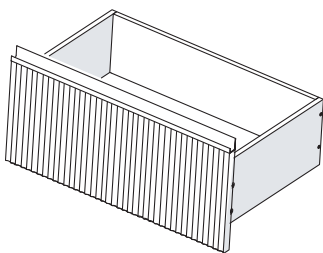
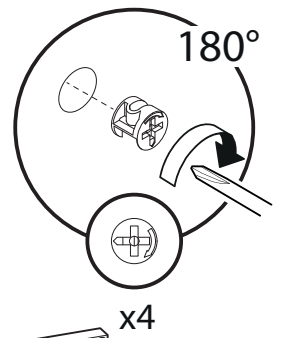
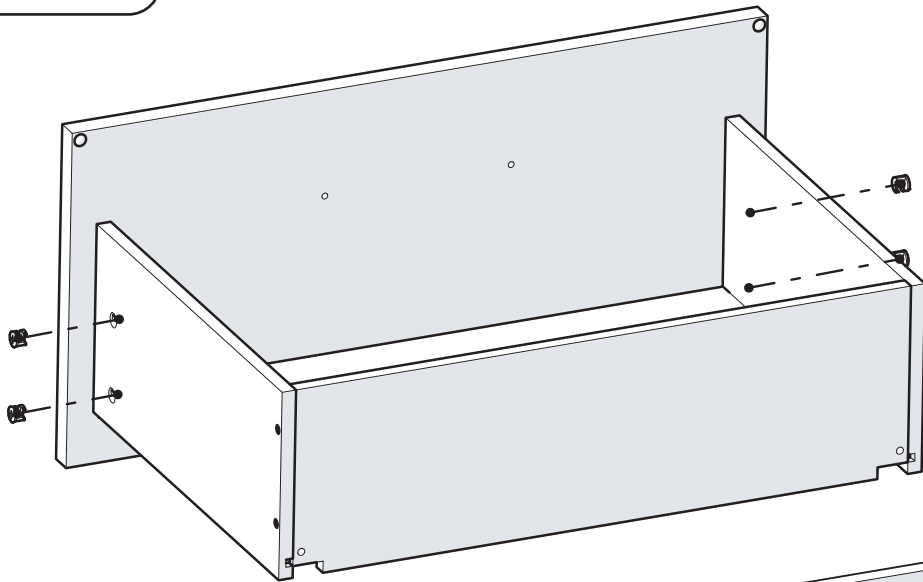
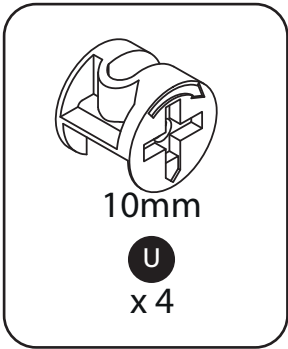
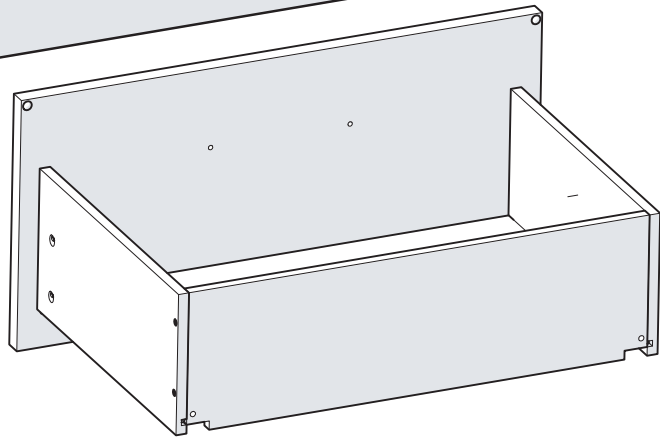
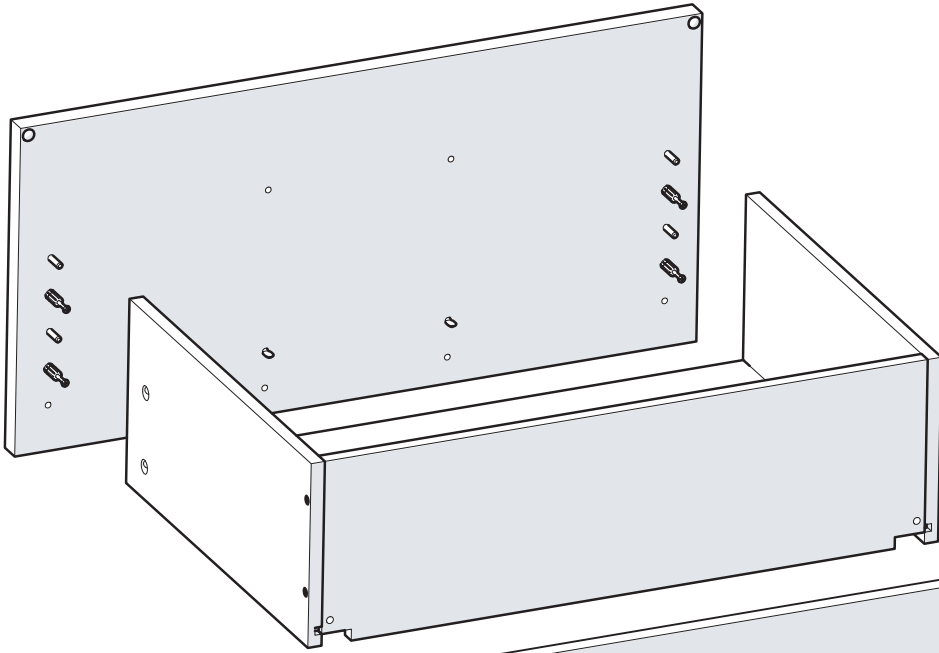

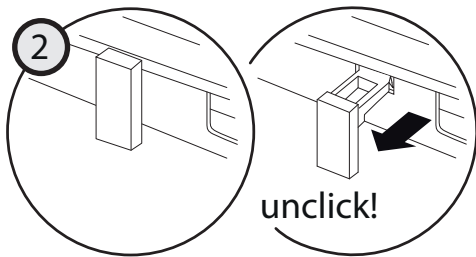
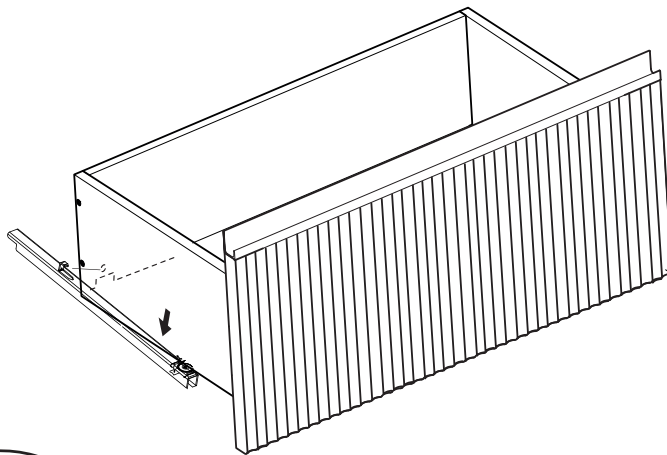
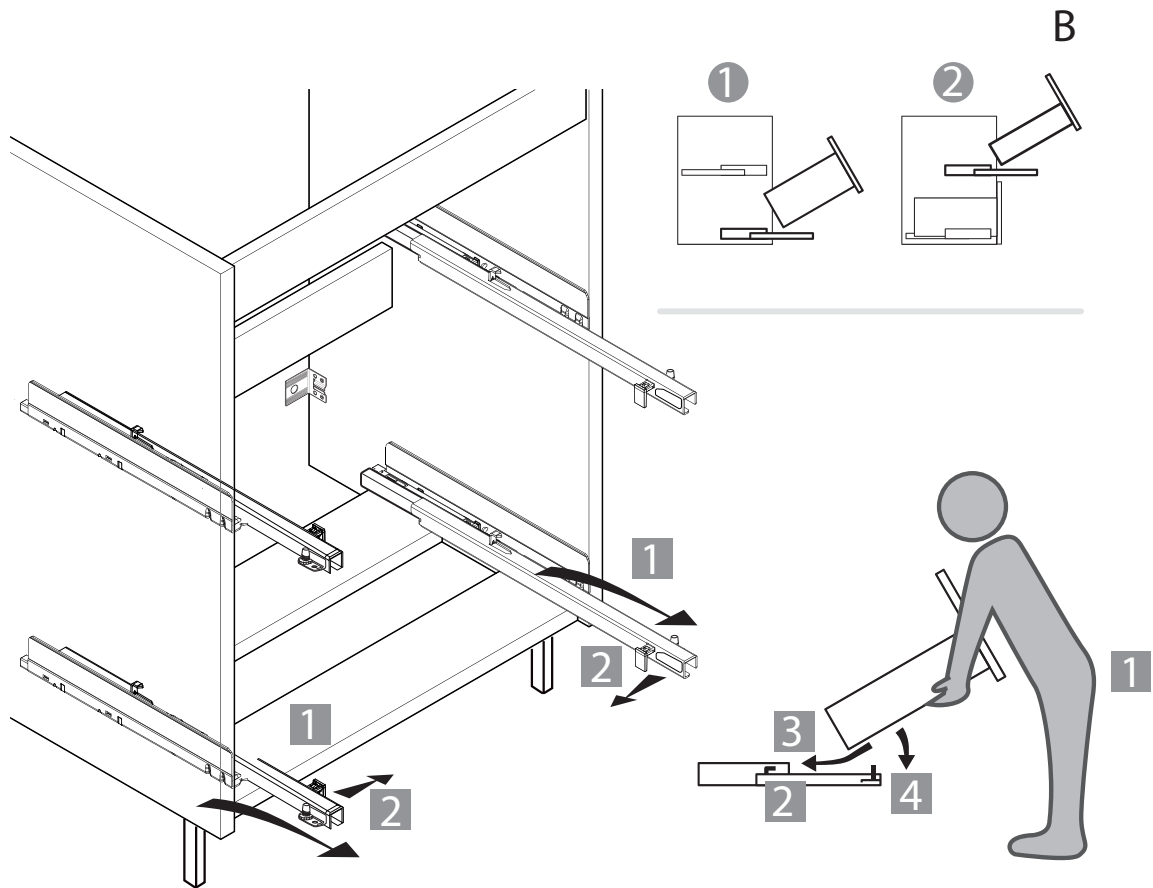

x2

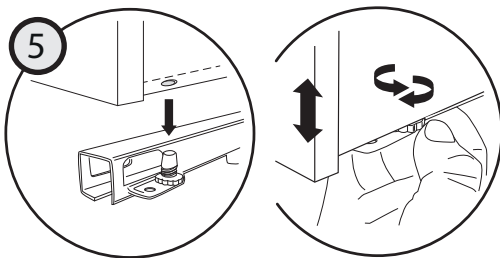

x2

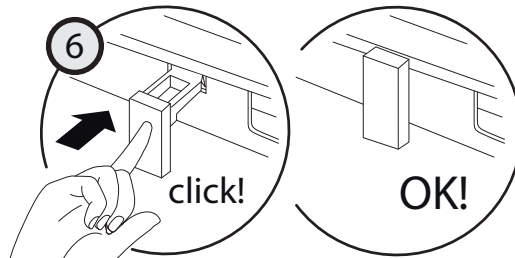

OK!

x2

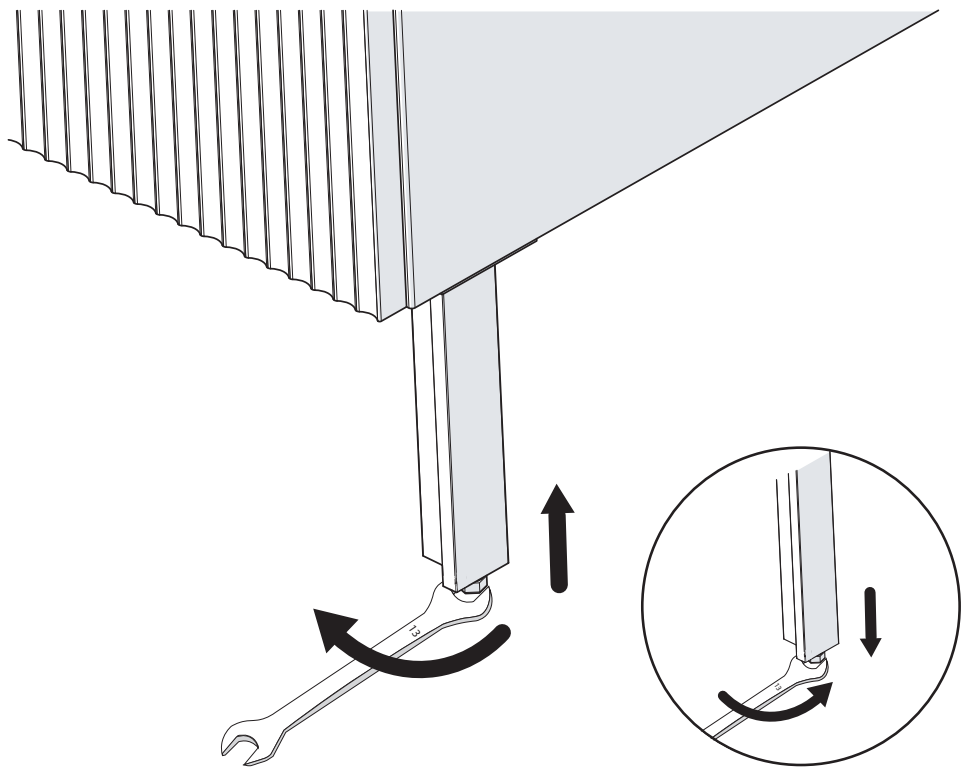
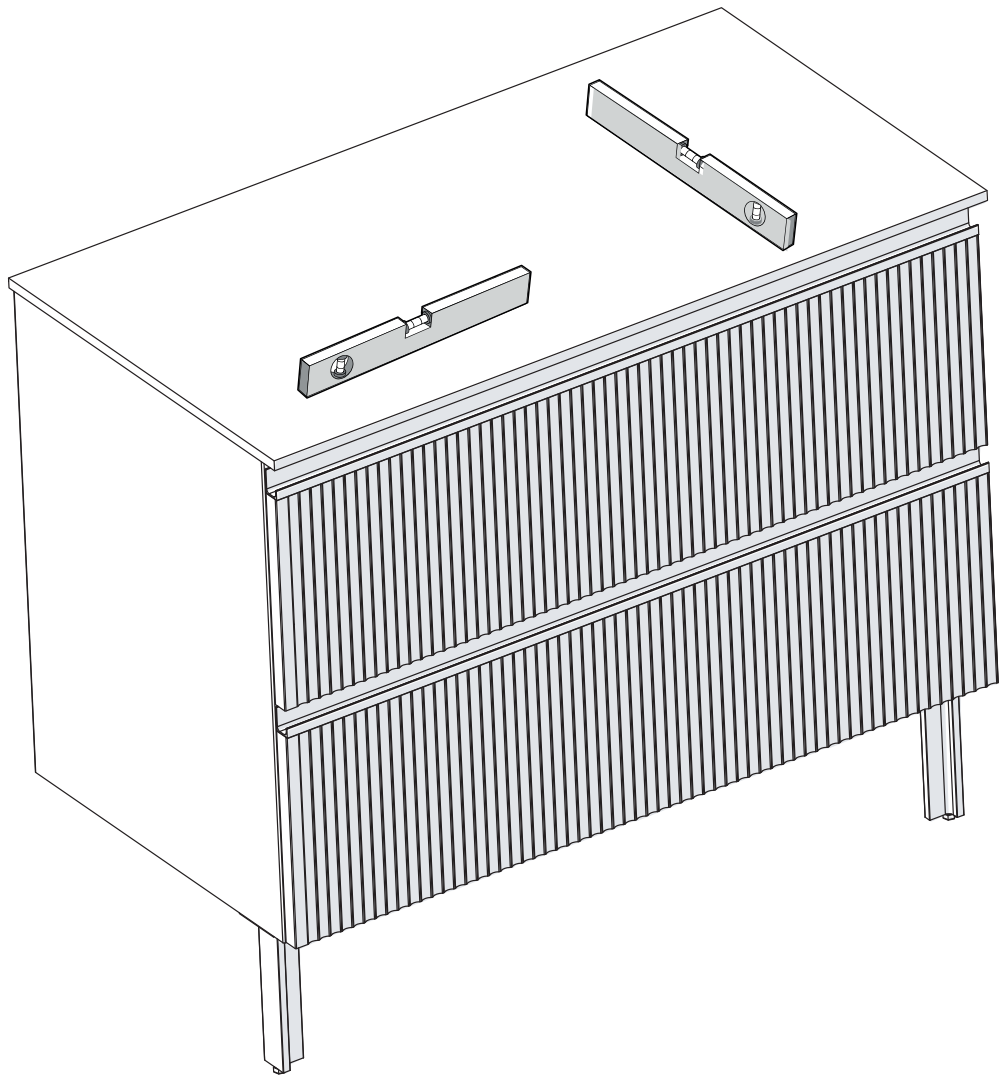

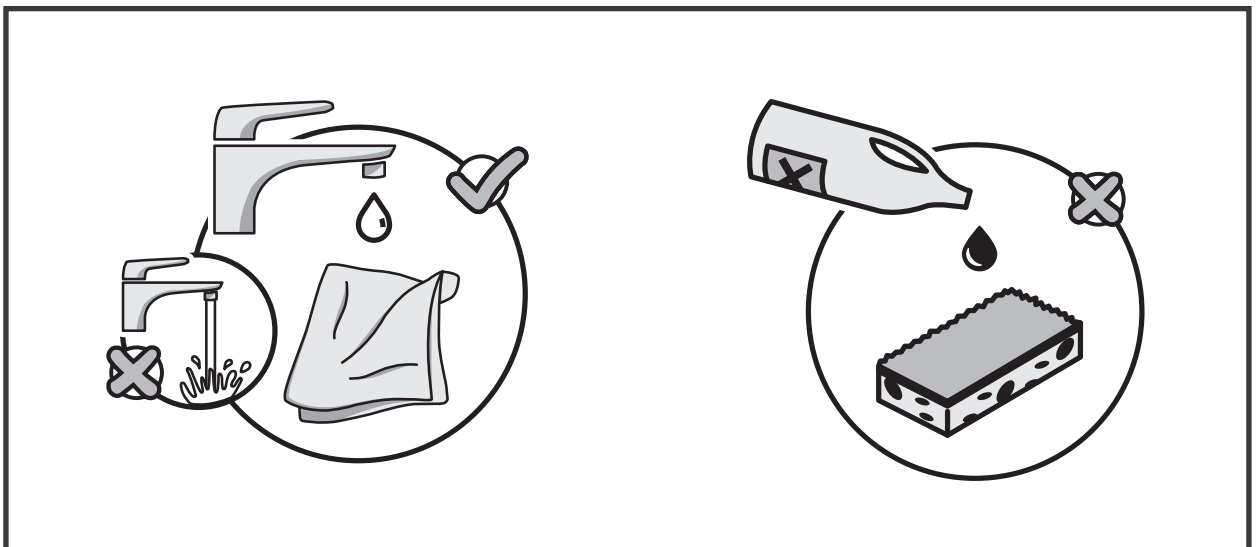
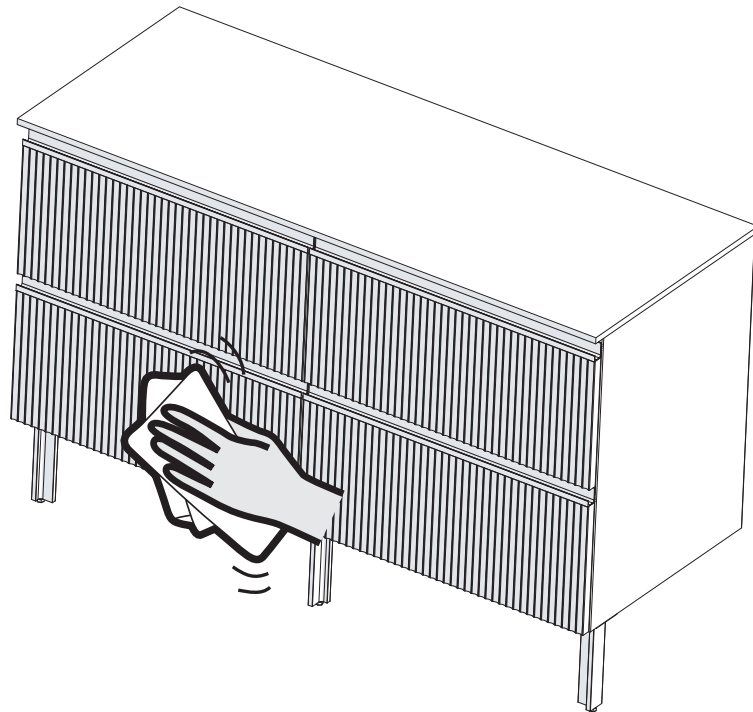
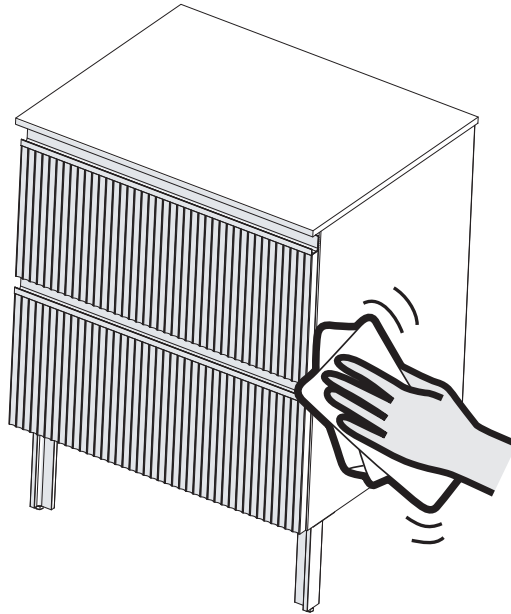

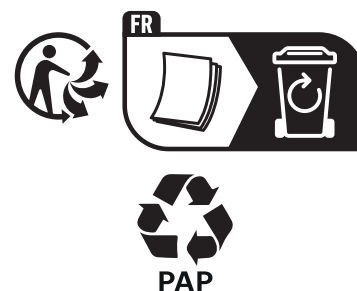

Garantie 10 ans / 10 años de garantía / Garantia de 10 anos / Garanzia 10 Anni / Εγγύηση 10 ετών /
Gwarancja 10-letnia / Гарантія 10 років / Garanție 10 ani / Garantia de 10 anos / 10 -year guarantee

Made in Italy

ADEO Services - 135 rue Sadi Carnot - CS 00001. 59790 RONCHIN – FRANCE

Imported by Adeo South Africa (PTY) LTD T/A
Leroy Merlin,
Hosted in Leroy Merlin Fourways Store 35 Roos
Street, Witkoppen Ext 97, Sandton, 2191
Johannesburg, Gauteng, South Africa
Tel: +27 10 493 8000 Email: contact@leroymerlin.co.za

Імпортер: ТОВ "Леруа Мерлен Україна", 04201
Україна, м.Київ, вул. Полярна 17А, +380 44 498
46 00. Імпортер приймає претензії від
споживачів щодо товару, а також проводить
його ремонт, технічне і гарантійне
обслуговування.

Importado e distribuído por LEROY MERLIN
COMPANHIA BRASILEIRA DE BRICOLAGEM
CNPJ: 01.438.784/0001-05
Rua Pascoal Pais, nº. 525, 6º andar cj 61 a 64,
Vila Cordeiro, São Paulo -SP. CEP: 04581-060
CALM (Central de Atendimento Leroy Merlin)
Capitais 4020-5376 Demais Regiões
0800-0205376