

QTz8 4X18

QUICKTRONIC QTz8 | ECG for T8/26 mm linear fluorescent lamps



Product family features

- Supply voltage: 220...240 V
- Line voltage: 198...264 V
- Line frequency: 50 Hz | 60 Hz
- Energy Efficiency Index EEI: A2
- Number of lamp switching cycles: up to 3,500

Product family benefits

- Compact housing
- Automatic restart after lamp replacement

Areas of application

- Public buildings
- Sports halls
- Strip lighting
- Suitable for luminaires of protection class I

Technical data

Electrical data

Nominal voltage	220...240 V
Mains frequency	50/60 Hz
Maximum output power	4 x 18 W
Efficiency in full-load	89 % ¹⁾
Operating frequency	30...45 kHz

¹⁾ at 230 V, 50 Hz

Dimensions & weight

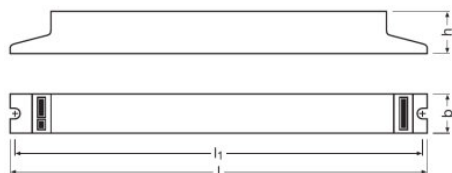

Length	210.0 mm
Width	40.0 mm
Height	30.0 mm
Mounting hole spacing, length	200.0 mm
Product weight	150.00 g

Temperatures & operating conditions

Ambient temperature range	-15...+50 °C
Permitted rel. humidity during operation	5...85 % ¹⁾

¹⁾ Maximum 56 days/year at 85 %

Lifespan

ECG lifetime	30000 h ¹⁾
--------------	-----------------------

¹⁾ At maximum T_c / 10% failure rate

Product datasheet

Expected Lifetime

Product name				
QTz8 4X18	ECG ambient temperature [ta]	50	-	-
	Temperature at tc-point [°C]	75	-	-
	Lifetime [h]	30000 ¹⁾	-	-

¹⁾ Max. 10% failure rate at tc max

Additional product data

Suitable for lamp power (4 lamps)	18 W
-----------------------------------	------

Capabilities

Suitable for fixtures with prot. class	I
Max. cable length to lamp/LED module	2.0 m / 1.0 m
Dimmable	No
Intended for no-load operation	No

Certificates & standards

Approval marks – approval	CE / CQC
EEL – Energy Label	A2
Protection class	II
Type of protection	IP20

Logistical data

Commodity code	850410809000
----------------	--------------

Wiring Diagram

QUICKTRONIC® QTz8

TYPE	QTz8 1x18	QTz8 1x18	QTz8 2x18	QTz8 2x18	QTz8 2x18	QTz8 2x18
MAX. I	34 A	34 A	34 A	15 A	15 A	15 A
MAX. I _{avg}	8 A (10 A)	8 A (10 A)	8 A (10 A)	8 A (10 A)	8 A (10 A)	8 A (10 A)
MAX. I _{peak}	30 A (40 A)	30 A (40 A)	30 A (40 A)	20 A (40 A)	20 A (40 A)	20 A (40 A)
MAX. I _{short}	70 A (100 A)	70 A (100 A)	70 A (100 A)	70 A (100 A)	70 A (100 A)	70 A (100 A)
I _{in}	< 30 A	< 30 A	< 30 A	< 30 A	< 30 A	< 30 A
τ _{in}	130 μs	130 μs	130 μs	200 μs	200 μs	200 μs

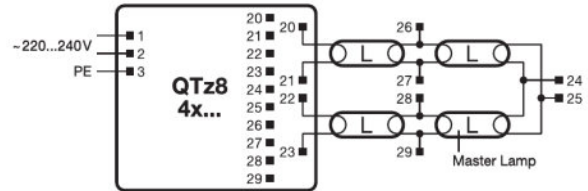
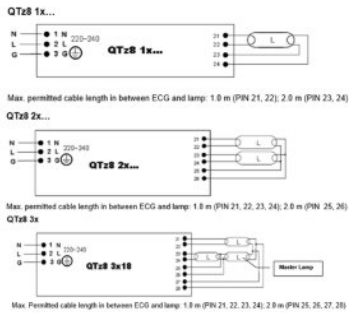

590718_EAC QTz8

723143_Wiring Diagram QTz8 4x...

Download Data

File	
	Certificates QTz CE 3384570 270421
	Certificates 592319_EAC certificate for Quicktronics QT
	Certificates CB Test Certificate CN42990
	Declarations of conformity 504183_DoC QTz8

Ecodesign regulation information:

Separate control gear and light sources must be disposed of at certified disposal companies in accordance with Directive 2012/19/EU (WEEE) in the EU and with Waste Electrical and Electronic Equipment (WEEE) Regulations 2013 in the UK. For this purpose, collection points for recycling centres and take-back systems (CRSO) are available from retailers or private disposal companies, which accept separate control gear and light sources free of charge. In this way, raw materials are conserved and materials are recycled.

Product datasheet

Logistical Data

Product code	Product description	Packaging unit (Pieces/Unit)	Dimensions (length x width x height)	Volume	Gross weight
4008321863362	QTz8 4X18	Shipping carton box 20	226 mm x 195 mm x 174 mm	7.67 dm ³	3065.00 g

The mentioned product code describes the smallest quantity unit which can be ordered. One shipping unit can contain one or more single products. When placing an order, for the quantity please enter single or multiples of a shipping unit.

Disclaimer

Subject to change without notice. Errors and omission excepted. Always make sure to use the most recent release.

QTz8 4X18

QUICKTRONIC QTz8 | ECG for T8/26 mm linear fluorescent lamps

Product name	Lamp group	Nominal current	Nominal wattage + Power loss	Power factor λ [PIM]	Luminous flux at 35 °C	Number of lighting outlets
QTz8 4X18	L 18 W	0.25 A	54.00 W	0.97	1350 lm	4