	816650001	816653001	816654001	816655001	816656001	816657001	816659001
	816660001	816661001	816662001	816663001	816664001	816665001	816666001
	816667001	816677001	816678001	816681001	816683001	816687001	816688001

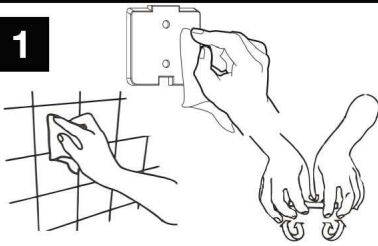

- E** ¡Importante! Aplicar sobre superficies planas y lisas, evitando las juntas de unión entre baldosas. No aplicar sobre superficies pintadas. Una vez que el artículo está fijado en la pared, no se puede cambiar su posición. Las propiedades adhesivas se perderán una vez el adhesivo haya curado. Limpiar con agua y jabón.
- GB** Important!!! To be placed on flat and plain surfaces, avoiding the joints of the tiles. Do not place on painted surfaces. Once the article is stuck in the wall, to not change its position. The adhesive properties will be totally lost. Clean with water and soap.
- F** Appliquer sur des surfaces planes et lisses, évitant les joints entre les carreaux. Ne pas utiliser sur les surfaces peintes. Une fois l'article accroché au mur, on ne peut pas modifier sa position. Les propriétés adhésives se perdront après l'avoir accroché au mur. Nettoyer avec de l'eau et du savon.
- DE** Wichtig! Nur auf glatte und ebene Oberflächen anbringen. Nicht auf die Fliesenfuge setzen. Lackierte Oberflächen vermeiden. Ist der Artikel einmal an der Wand befestigt, kann seine Position nicht mehr verändert werden. Die Klebeeigenschaften gehen nach der Befestigung an der Wand verloren. Mit Wasser und Seife reinigen.
- I** Applicare su superfici lisce e piane, schivando le giunzioni tra le piastrelle. Non utilizzare su superfici verniciate. Una volta che l'articolo è fissato alla parete, non è possibile cambiarne la posizione. Le proprietà adesive si perderanno una volta fissato alla parete. Pulire con acqua e sapone.
- P** ¡Importante! Aplicar sobre superficies planas e lisas, evitando as juntas de união entre azulejos. Não aplicar sobre superficies pintadas. Uma vez que o artigo esteja pendurado na parede não se pode mudar a sua posição. A propriedade adesiva perder-se-ão uma vez que o artigo esteja preso na parede. Limpar com água e sabão.

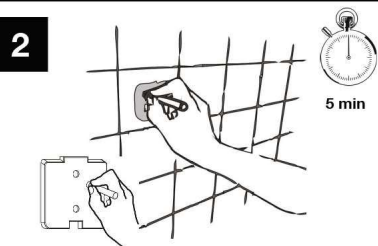

- E** Limpiar la superficie de apoyo con una solución de agua y alcohol al 50%. Apretar Primer-94 para romper la cápsula interna hasta que el líquido moje el tampón.
- GB** Clean mounting surface using a solution of 50/50 common rubbing alcohol and water. Break the inner capsule of the Primer - 94 and press until the brush is soaked.
- F** Nettoyez la surface d'appui avec une solution d'alcool et d'eau (diluer à 50%). Cassez la capsule intérieure du Primer-94 jusqu'à ce que le tampon soit imprégné.
- DE** Die Anbringfläche mit einer Lösung aus 50% Wasser und 50% Alkohol reinigen. Die Kapsel mit der Grundierung aufbrechen und so lange drücken, bis der Pinsel mit Flüssigkeit getränkt ist.
- I** Pulire la superficie d'appoggio con una soluzione d'acqua e alcool al 50%. Spezzare la capsula di Primer-94 e premere finno a che il pennellino si imbeve di liquido.
- P** Limpar a superfície de apoio com uma solução de água e álcool a 50%. Apertar o Primer-94 para partir a cápsula interna até o líquido molhar a tampa.



- E** Aplicar una fina capa de Primer - 94 tanto sobre la base del soporte pared como en la pared para aumentar la adherencia y DEJAR SECAR 5 MINUTOS. ¡IMPORTANTE! No usar el Primer - 94 sobre el adhesivo.
- GB** Apply a thin uniform coating to both wall bonding surface of accessory and mounting surface in order to increase adherence. Allow Primer-94 to dry thoroughly before applying tape. This is usually accomplished in 5 minutes.
- F** Appliquer une couche fine de Primer-94 sur la base du support ainsi que sur le mur pour augmenter l'adhérence et LAISSER AGIR 5 MINIUTES. ATTENTION ! Ne pas utiliser Primer-94 sur l'adhésif.
- DE** Tragen Sie eine dünne Schicht Primer-94 (Klebstoff) sowohl auf der Grundlage der Wandhalterung wie auch auf der Klebefläche der Wand auf. Um die Haftung zu erhöhen muss es 5 MINUTE-TROCKNEN. ¡WICHTIG! Nicht den Klebstoff auf den Aufkleber streichen.
- I** Applicare una fine cappa di Primer-94 sulla base del supporto parete e anche nella parete per aumentare l'aderenza e LASCIARE ASCIUGARE 5 minuti. ¡IMPORTANTE ! Non usare Primer-94 sull'adesivo.
- P** Limpar a superfície de apoio com uma solução de água e álcool a 50%. Apertar o Primer-94 para partir a cápsula interna até o líquido molhar a tampa.

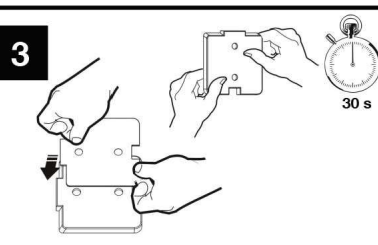

- E** Pegar el adhesivo 3M a la base del soporte pared. ¡IMPORTANTE! Presionar fuertemente el adhesivo 3M durante 30 segundos aproximadamente.
- GB** Stick 3M tape to wall bonding surface of accessory and firmly press for 30 seconds.
- F** Collez l'adhésif 3M sur la base du support mur. IMPORTANT ! Appuyer fermement sur l'adhésif 3M pendant 30 secondes approximativement.
- DE** Den Aufkleber 3M auf die Grundlage der Wandhalterung kleben. ¡WICHTIG! Drücken Sie, ca. 30 Sekunden lang, fest auf den Aufkleber 3M.
- I** Attaccare l'adesivo 3M alla base del supporto parete. ¡IMPORTANTE! Pressare fortemente l'adesivo 3M per 30 secondi approssimativamente.
- P** Colar o adesivo 3M à base do suporte de parede. ¡IMPORTANTE! Pressionar com força o adesivo 3M durante 30 segundos.

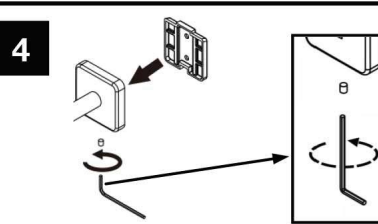

- E** Montar el soporte pared en el artículo.
- GB** Assemble wall mounting set on accessory.
- F** Monter le support mur sur l'article.
- DE** Montieren Sie die Wandhalterung auf das Teil.
- I** Montare il supporto parete sull'articolo.
- P** Montar o suporte de parede no artigo.

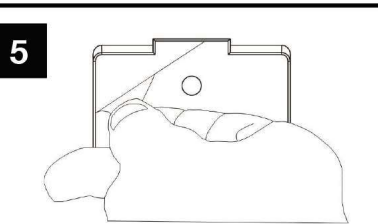

- E** Retirar la protección del adhesivo. No tocar con los dedos.
- GB** Remove protection of tape. Do not touch with your fingers.
- F** Enlever la protection de l'adhésif. Ne pas le toucher avec les doigts.
- DE** Das Klebeband vom Aufkleber abziehen und nicht mit den Fingern berühren.
- I** Togliere la protezione dell'adesivo. Non toccarlo con le dita.
- P** Retirar a protecção do adesivo. Não tocar com os dedos.

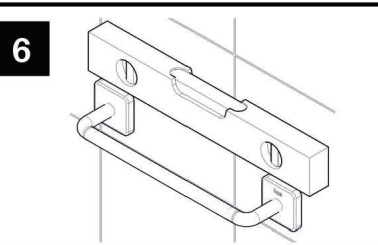

- E** Para los artículos con 2 soportes verificar la alineación de los soportes antes de pegar.
- GB** In case of accessories with two wall bonding surfaces, check alignment before sticking.
- F** Pour les articles avec 2 supports, vérifier l'alignement des supports avant de coller.
- DE** Bei Artikel mit 2 Wandhalterungen sollte, vor dem Aufkleben, auf die Ausrichtung geachtet werden.
- I** Per gli articoli con 2 supporti, verificare l'allineamento dei supporti prima d'incollare.
- P** Para os artigos com 2 suportes, verificar o alinhamento dos suportes antes de colar.

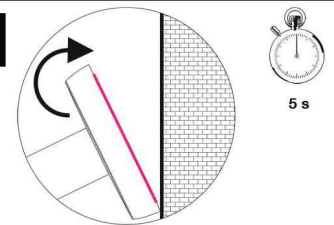

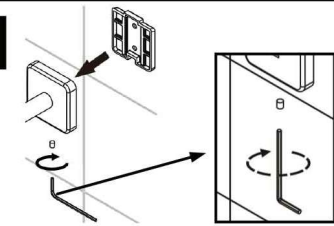

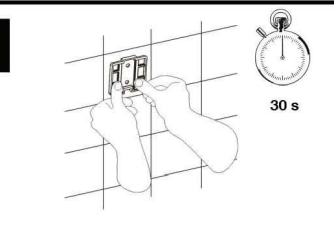

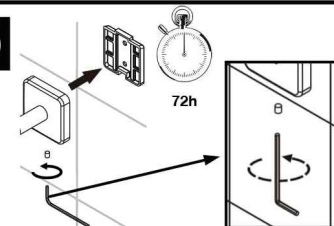



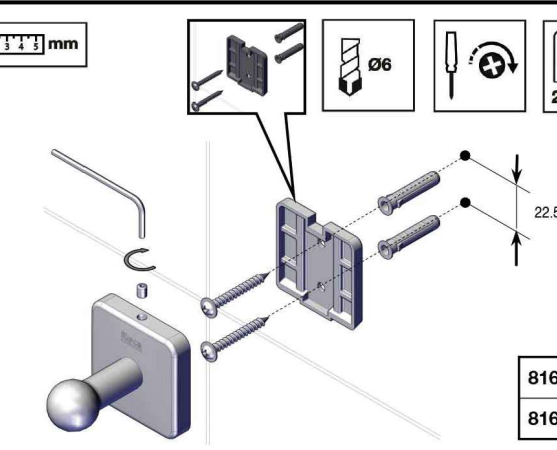







**7**  **E** Colocar sobre la pared comenzando desde el borde inferior del embellecedor. Apretar el artículo contra la pared 5 segundos.  
**GB** Place accessory on the wall starting from bottom edge of the escutcheon and press against the wall for 5 seconds.  
**F** Placer sur le mur en commençant à partir du bord inférieur de l'enjoliveur. Appuyer l'article contre le mur 5 secondes.  
**DE** Ausgehend von der Unterkante der Rosette das Teil auf die Wand platzieren und 5 Sekunden lang gegen die Wand drücken.  
**I** Collocare sulla parete cominciando dal bordo inferiore della borchia. Stringere l'articolo contro la parete 5 secondi.  
**P** Colocar o artigo na parede começando pelo bordo inferior do embelezador. Pressionar o artigo contra a parede durante 5 segundos.











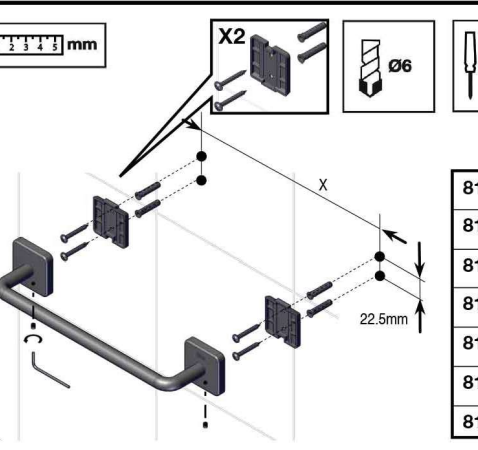







**8**  **E** Separar el artículo del soporte pared, desatornillando el tornillo del embellecedor con la llave Allen.  
**GB** Separate accessory from wall mounting set using an allen key.  
**F** Séparer l'article du support mur, en dévissant la vis de l'enjoliveur avec la clef allen.  
**DE** Die Madenschraube an der Rosette lösen und das Teil von der Wandhalterung entfernen.  
**I** Separare l'articolo dal supporto parete, svitando la vite della borchia con la chiave Allen.  
**P** Separar o artigo do suporte de parede, desaparafusar o parafuso do embelezador com a chave sextavada.

**9**  **E** ¡IMPORTANTE! Apretar fuertemente el soporte contra la pared durante 30 segundos.  
**GB** IMPORTANT: Firmly press wall mounting set on wall for 30 seconds.  
**F** IMPORTANT! Serrer fermement le support contre le mur pendant 30 secondes.  
**DE** ¡WICHTIG! Drücken Sie die Wandhalterung ca. 30 Sekunden fest gegen die Wand.  
**I** IMPORTANTE! Stringere fortemente il supporto contro la parete per 30 secondi.  
**P** IMPORTANTE!! Pressionar com força o suporte contra a parede durante 30 segundos.











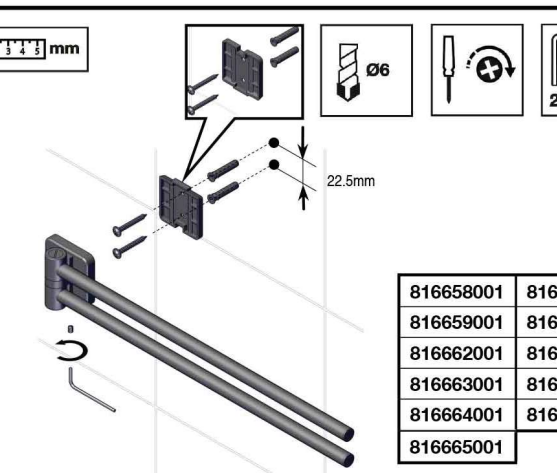







**10**  **E** Pasadas 72h, fijar de nuevo el artículo al soporte pared atornillando el tornillo al embellecedor con la llave Allen.  
**GB** IMPORTANT: Accessory can be assembled back in the wall mounting set after 72 hours.  
**F** Attendez 72 h et fixer à nouveau l'article sur le support mur en vissant la vis sur l'enjoliveur à l'aide de la clé Allen.  
**DE** Nach 72 Stunden, kann das Teil wieder auf die Wandbefestigung montiert und die Madenschraube an der Rosette angezogen werden.  
**I** Attendere 72h e fissare di nuovo l'articolo al supporto parete avvitando la vite sulla borchia con la chiave Allen.  
**P** Passadas 72 h, fixar novamente o artigo ao suporte de parede aparafusando o parafuso ao embelezador com a chave sextavada.











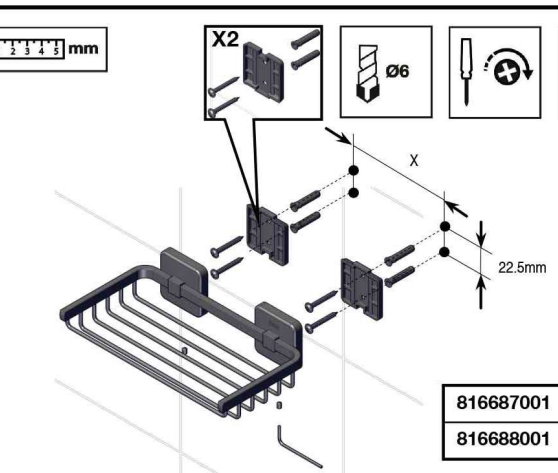









 **E**     
**GB**     
**F**     
**DE**     
**I**     
**P**     
 816650001  
 816666001

 **E**     
**GB**     
**F**     
**DE**     
**I**     
**P**     

	X
816653001	250
816654001	350
816655001	450
816656001	550
816657001	750
816660001	556
816661001	550

 **E**     
**GB**     
**F**     
**DE**     
**I**     
**P**     
 816658001 816667001  
 816659001 816677001  
 816662001 816678001  
 816663001 816681001  
 816664001 816683001  
 816665001

 **E**     
**GB**     
**F**     
**DE**     
**I**     
**P**     

	X
816687001	116
816688001	170



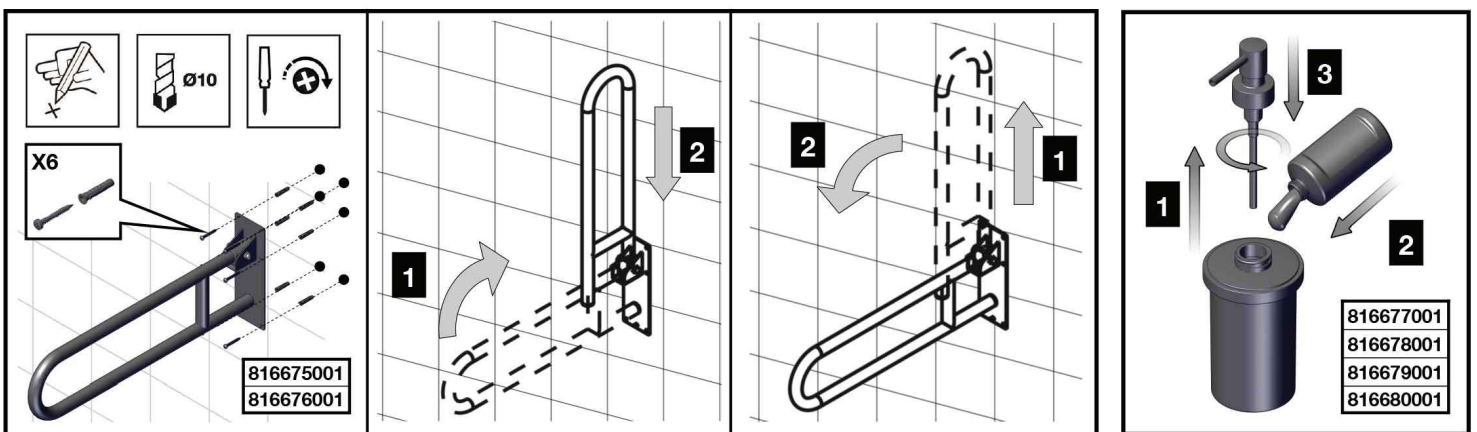
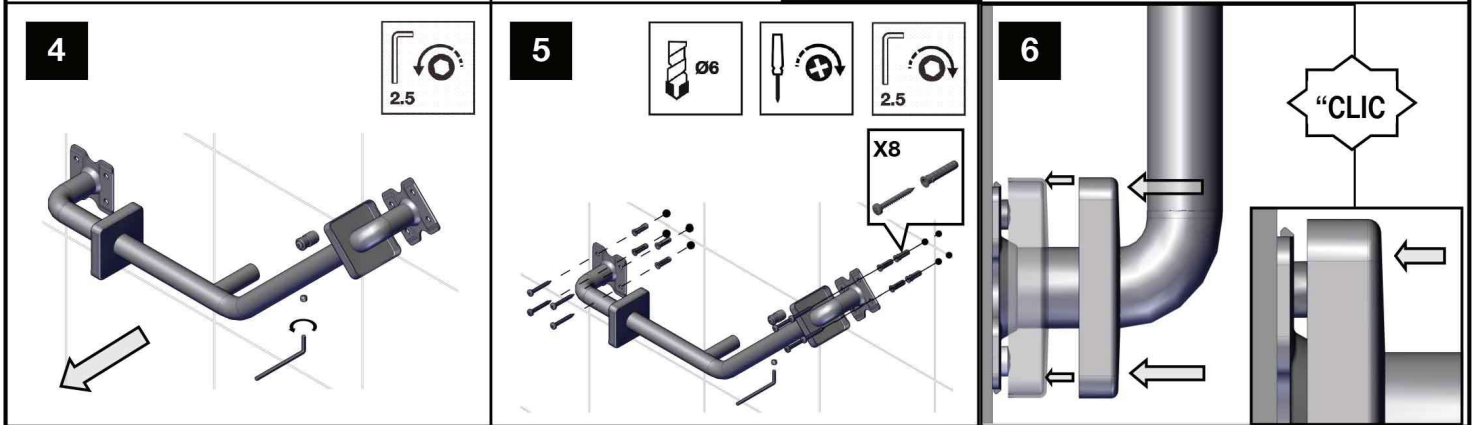
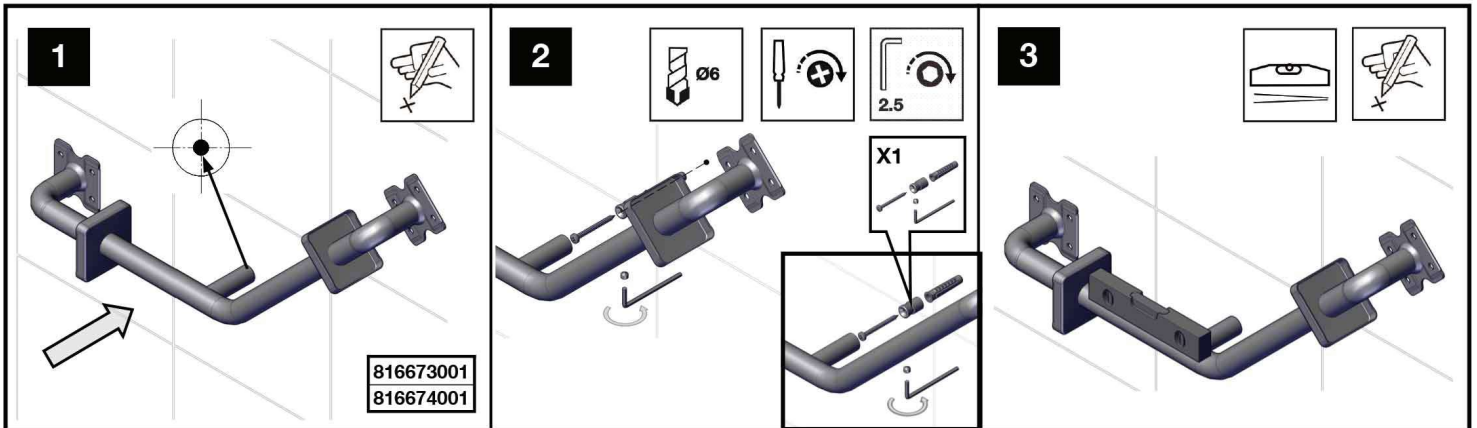
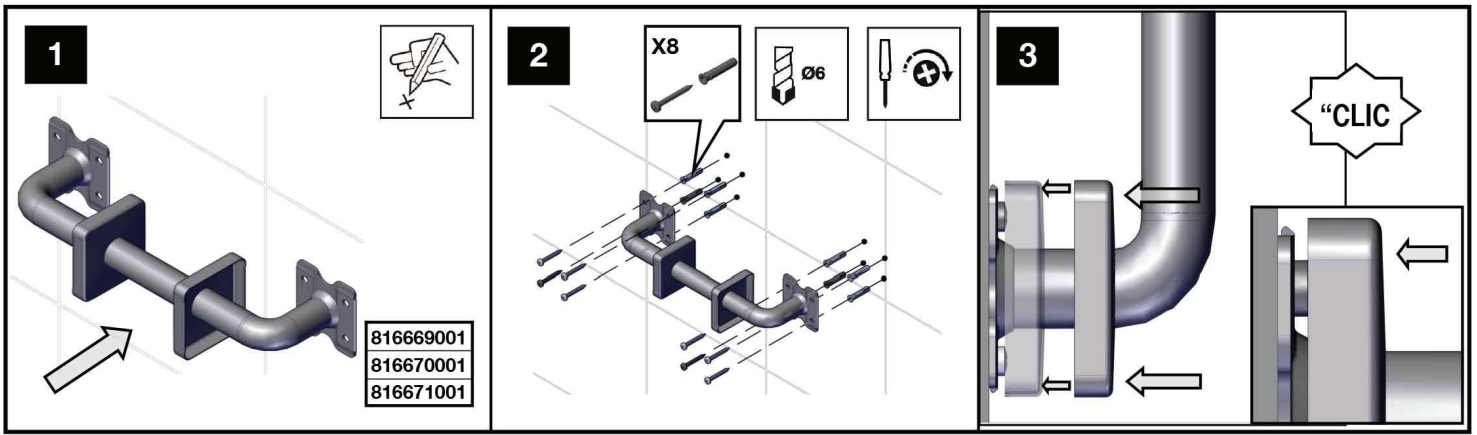

**E** - En caso de instalación en paredes de placas de yeso laminado recomendamos utilizar los siguientes tacos: *Fisher Universal Plug F1, UX o UV*, o bien, tipo *Toggler* o *Fisher HDF*. Este tipo de tacos no son suministrados por Roca Sanitario, S.A.

**I** - Nel caso d'installazione in pareti di piastre di gesso laminato, raccomandiamo usare i seguenti tasselli: *Fisher Universal Plug F1, UX o UV*, o bene, tipo *Toggler* o *Fisher HDF*. Questo tipo di tasselli non è fornito da Roca Sanitario, S.A.

**F** - En cas d'installation sur des parois en plaques de plâtre laminé, nous recommandons d'utiliser les chevilles suivantes: *Fisher Universal Plug F1, UX ou UV*, ou bien *Toggler* ou *Fisher HDF*. Ce type de chevilles n'est pas fourni par Roca Sanitario, S.A.

**GB** - In case of installation in walls of laminated plaster we recommend using the following wall plugs: *Fisher Universal Plug F1, UX or UV*, or *Toggler* or *Fisher HDF*. This kind of wall plugs is not supplied by Roca Sanitario, S.A.

**DE** - Ist der Artikel einmal an der Wand befestigt, kann seine Position nicht mehr verändert werden: *Fisher Universal Plug F1, UX o UV*, oder die vom Typ *Toggler* oder *Fisher HDF*. Diese Dübel werden nicht von Roca Sanitario, S.A. mitgeliefert.

**P** - Em caso de instalação em paredes de placas de gesso laminado recomendamos a utilização das seguintes fixações: *Fisher Universal Plug F1, UX ou UV*, ou do tipo *Toggler* ou *Fisher HDF*. Este tipo de fixações não são fornecidas pelas Roca Sanitario, S.A.

**Roca**

902  
304  
848

Línea de  
Atención al  
Consumidor



902  
400  
423

Servicio  
Técnico  
Sanitario



Roca Sanitario, S.A.  
Avda. Diagonal, 513  
08029 Barcelona - SPAIN  
Tel.: 93 366 1200 - Fax: 934194501  
www.roca.es