

Tornillo PVP

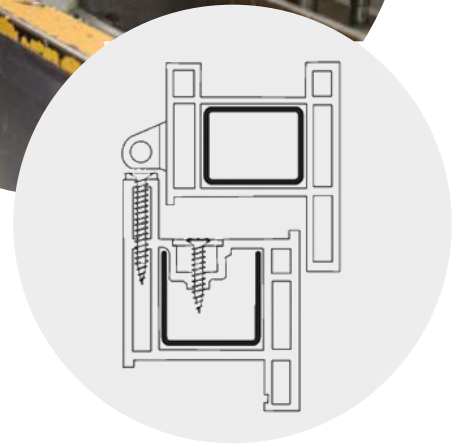

Cincado



Bicromatado



Lacado blanco



PVP cincado. Tornillo para PVC, rosca plástico

Código	d _s	L _s	L _{th}	d _h	H _k	Impronta	Precio €/100 u	[Unds]	[Unds]
94116PVP	4.1	16	11	7.3	2.8	PH2	2,50	1000	16000
94119PVP	4.1	19	14	7.3	2.8	PH2	2,70	1000	16000
94122PVP	4.1	22	17	7.3	2.8	PH2	2,90	500	8000
94125PVP	4.1	25	20	7.3	2.8	PH2	3,20	500	8000
94130PVP	4.1	30	25	7.3	2.8	PH2	3,40	500	8000
94138PVP	4.1	38	33	7.3	2.8	PH2	4,20	500	4000
94145PVP	4.1	45	40	7.3	2.8	PH2	4,90	500	4000
94155PVP	4.1	55	50	7.3	2.8	PH2	6,20	250	2000



PVP Bicromatado. Tornillo para PVC, rosca plástico

Código	d _s	L _s	L _{th}	d _h	H _k	Impronta	Precio €/100 u	[Unds]	[Unds]
94138PVP	4.1	38	33	7.3	2.8	PH2	4,20	500	4000



PVP Lacado blanco. Tornillo para PVC, rosca plástico

Código	d _s	L _s	L _{th}	d _h	H _k	Impronta	Precio €/100 u	[Unds]	[Unds]
9W4125PVP	4.1	25	20	7.3	2.8	PH2	8,60	500	8000
9W4138PVP	4.1	38	33	7.3	2.8	PH2	11,50	500	4000

Características



Cabeza **avellanada** con estrias



Impronta **philips (PH)**



Punta **S**

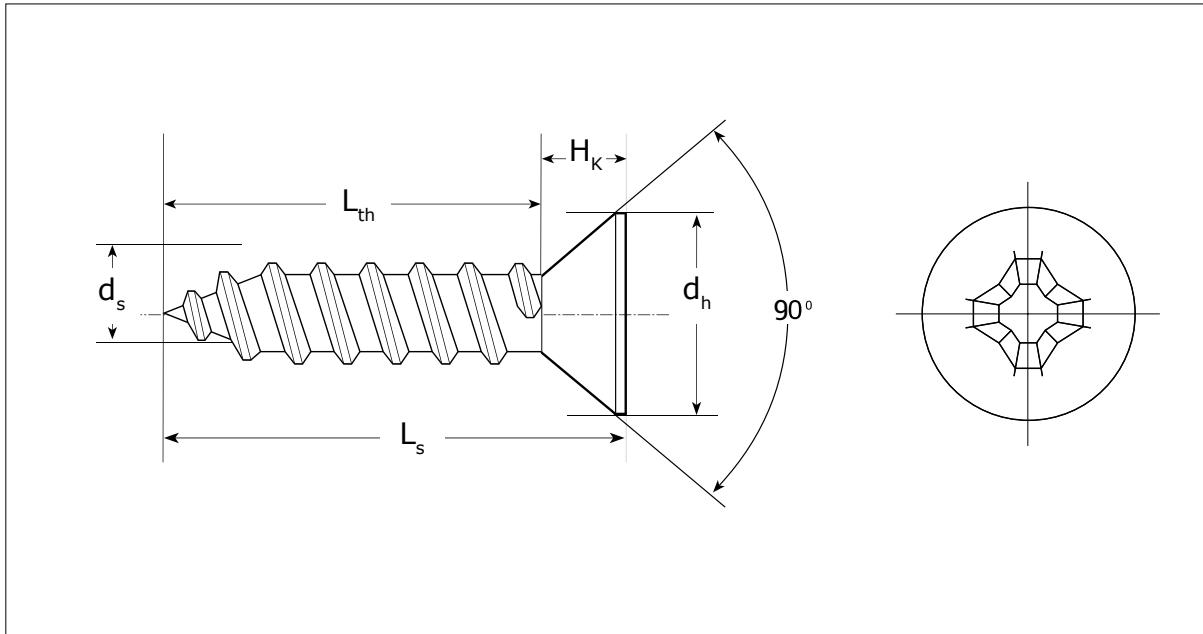

Su aplicación principal es la **fijación de los herrajes perimetrales** en el perfil de PVC.

Cabeza avellanada con estrías. Se puede usar en montaje automático o manual.

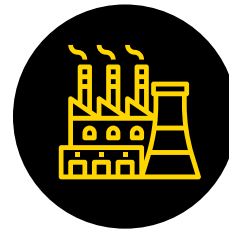

Fabricado en acero al **carbono** y recubrimiento **cincado** .

Disponibilidad de un recubrimiento (láminas de zinc) de alta resistencia a la corrosión (240 HNS) bajo pedido.