

391384 - 00



Demeyere
GROUP

- (FR)** NOTICE DE MONTAGE
- (EN)** ASSEMBLY INSTRUCTIONS
- (DE)** MONTAGEANLEITUNG
- (ES)** INSTRUCCIONES DE MONTAJE
- (NL)** MONTAGEVOORSCHRIFT
- (IT)** ISTRUZIONI DI MONTAGGIO
- (PT)** INSTRUÇÕES DE MONTAGEM
- (CR)** NAPUTCI ZA MONTAŽU
- (HU)** ÖSSZESZERELÉSI UTASÍTÁSOK

تعليمات التركيب (ع)

 **Max**
19Kg / 41.9Lbs

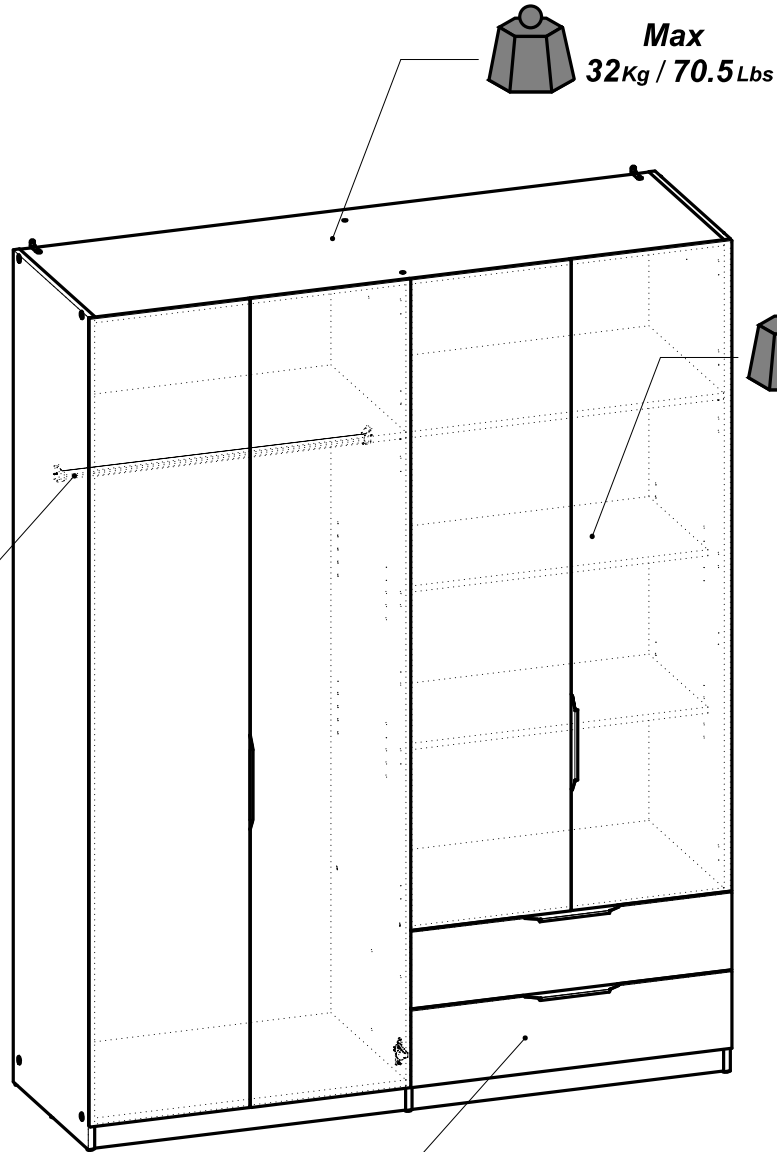

 **Max**
32Kg / 70.5Lbs

 **Max**
16Kg / 35.3Lbs

 **Max**
5Kg / 11Lbs

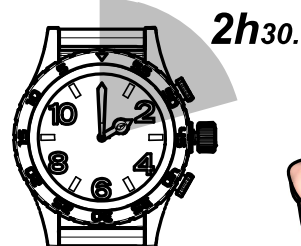

180047



Fabriqué en France
Made in France

C.B.A Meubles - 178-184 rue de la Prévôté
59840 Pérenchies - FRANCE
contact@demeyere.fr

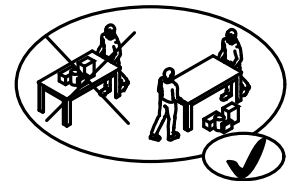
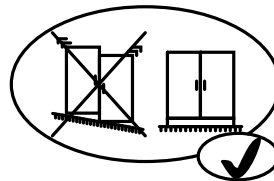
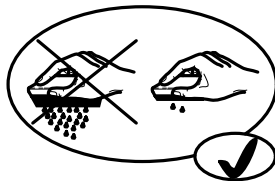
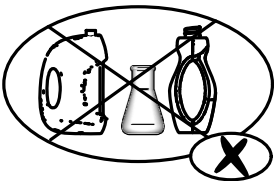
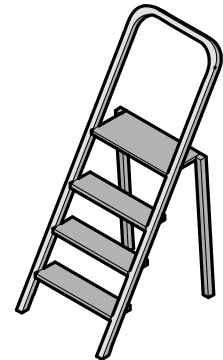
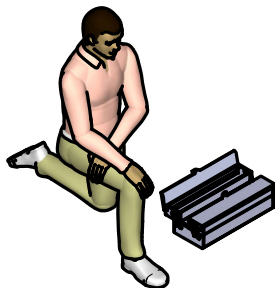
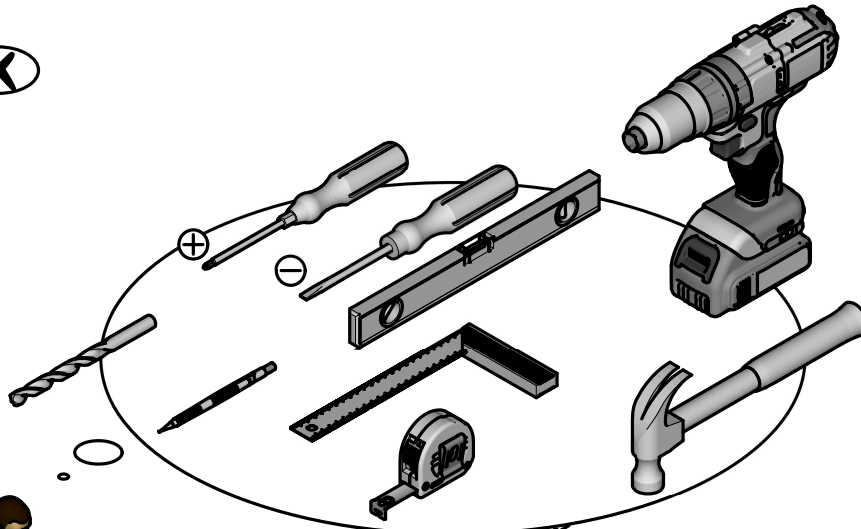
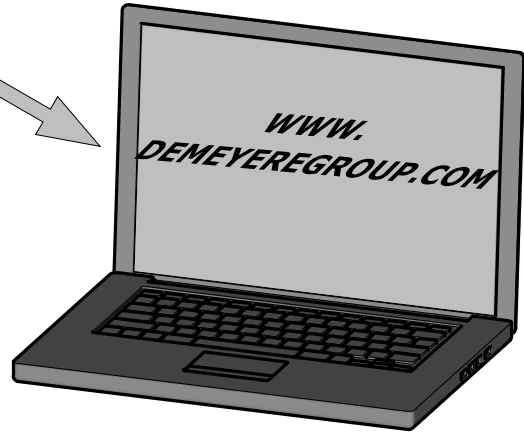
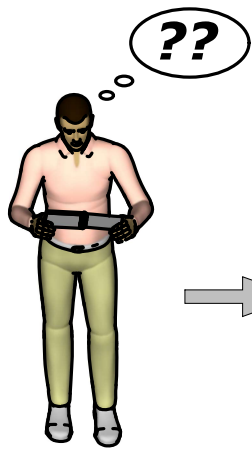

Donnez ou recyclez vos meubles.



Association

ou



Magasin

ou



Déchèterie

<https://quefaire.demescheets.fr>



A x1

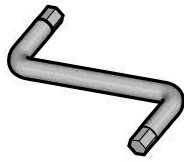

B x2

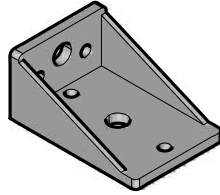

C x8

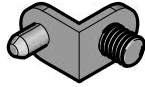

D x2

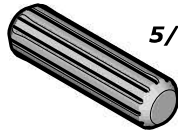

8x30mm
5/16" x 1 3/16"

E x8

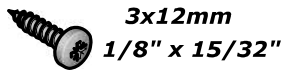

3x12mm
1/8" x 15/32"

F x34

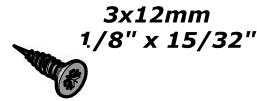

3x12mm
1/8" x 15/32"

G x2

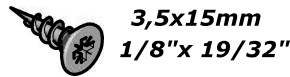

3,5x15mm
1/8" x 19/32"

H x8



I x2



Ø8mm
Ø5/16"

J x1

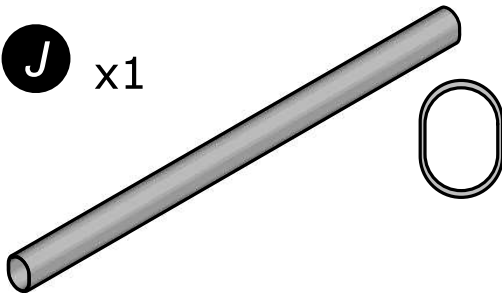

K x2

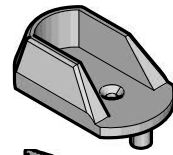

L x1

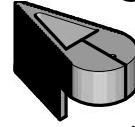

M x3

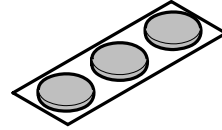

N x12

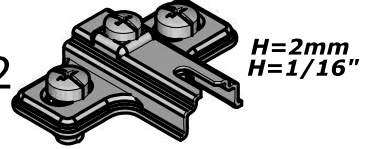

H=2mm
H=1/16"

O x6

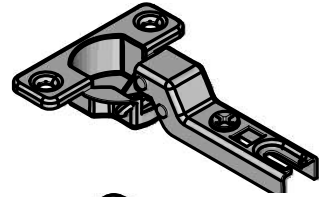

P x6

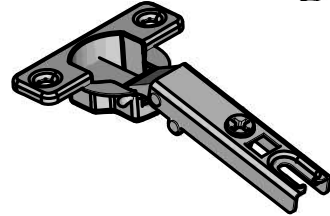

Q x14

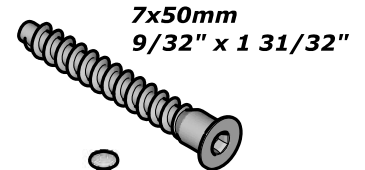

7x50mm
9/32" x 1 31/32"

R x2



S x2

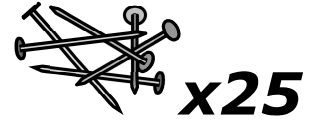

x25

T x4

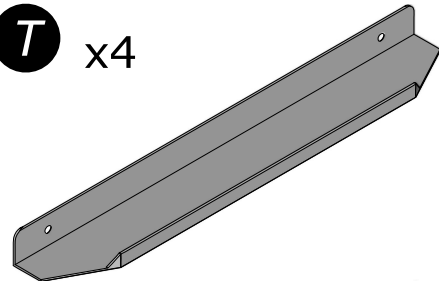

U x2

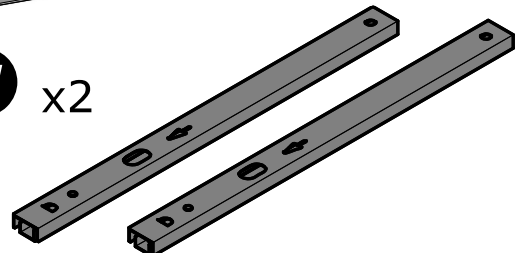

0 1 2 3 4 5 6 7 8 9 10 cm

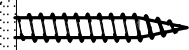

0 1 2 3 4 in

V x1

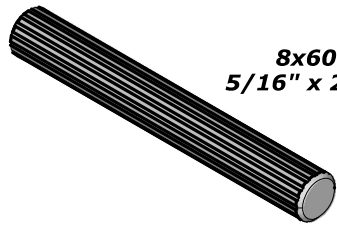

8x60mm
5/16" x 2 3/8"

AG x2

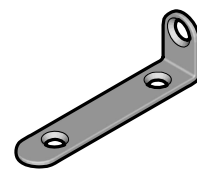

W x8



6,3x9mm
1/4" x 11/32"

X x8



3x16mm
1/8" x 5/8"

Y x4



4x9mm
5/32" x 11/32"

Z x4

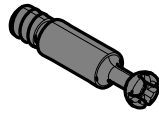

AA x8

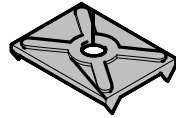

AB x4



Ø12mm
Ø15/32"

AC x4

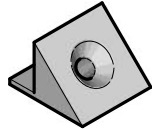

AD x4



3x16mm
1/8" x 5/8"

AE x8



AF x8

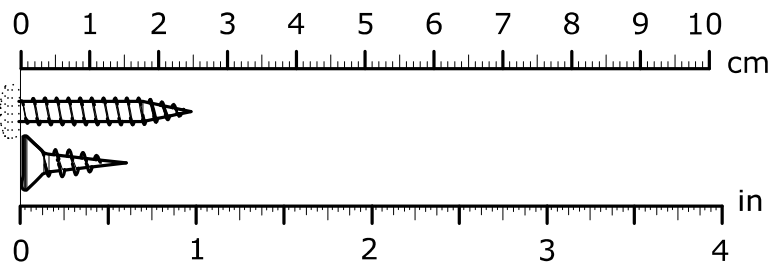
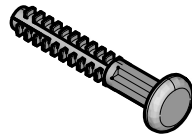

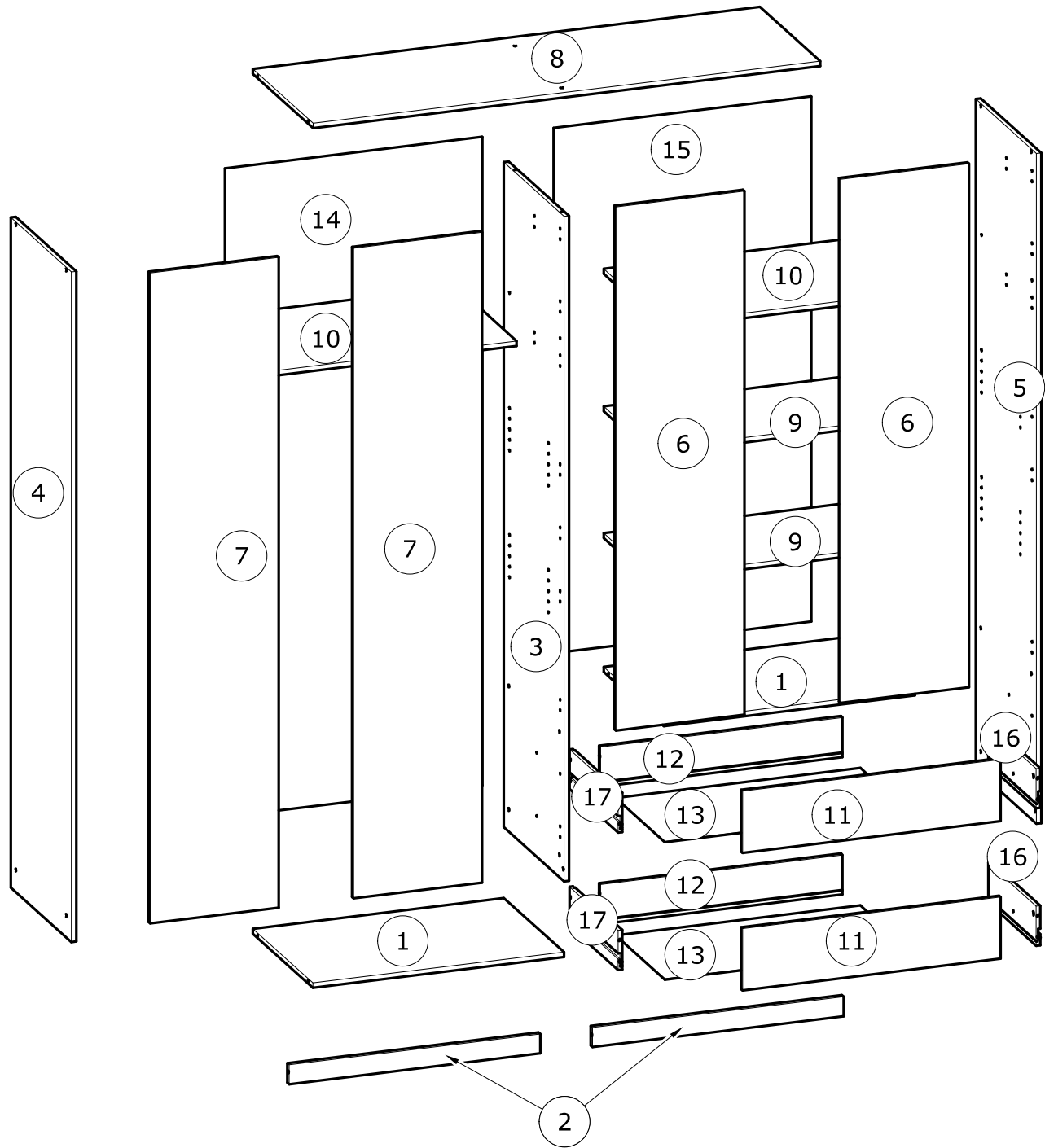

N°	MM		INCH		QTY
1	764	x 496	30 1/16	x 19 8/16	2
2	764	x 59	30 1/16	x 2 5/16	2
3	2 014	x 497	79 5/16	x 19 9/16	1
4	2 030	x 499	79 15/16	x 19 10/16	1
5	2 030	x 499	79 15/16	x 19 10/16	1
6	1 586	x 391	62 7/16	x 15 6/16	2
7	1 970	x 391	77 9/16	x 15 6/16	2
8	1 543	x 498	60 12/16	x 19 10/16	1
9	764	x 391	30 1/16	x 15 6/16	2

N°	MM		INCH		QTY
10	764	x 496	30 1/16	x 19 8/16	2
11	785	x 187	30 14/16	x 7 6/16	2
12	736	x 120	29	x 4 12/16	2
13	742	x 398	29 3/16	x 15 11/16	2
14	1 964	x 783	77 5/16	x 30 13/16	1
15	1 590	x 783	62 10/16	x 30 13/16	1
16	400	x 120	15 12/16	x 4 12/16	2
17	400	x 120	15 12/16	x 4 12/16	2

FR

AVERTISSEMENT : MEUBLE A FIXER IMPERATIVEMENT AU MUR AFIN D'EVITER SON BASCULEMENT

- Pour installer correctement ce produit et éliminer les risques pour votre sécurité, merci de suivre exactement ce manuel d'instruction.
- Fixer le meuble au mur avec les attaches prévues à cet effet
- Les vis et les chevilles ne sont pas fournies. Utiliser des vis et des chevilles adaptées au support.

EN

WARNING: FURNITURE TO BE ATTACHED TO THE WALL TO PREVENT OVERTURNING

- Installation shall be carried out exactly according to those instructions-otherwise a safety risk can occur if incorrectly installed;
- Attach the furniture to the wall with the fastening provided for this purpose
- Screw and Pegs are not supplied. Use Screws and pegs adapted to the support.

DE

WARNUNG: DAS MÖBEL MUSS AN DER WAND BEFESTIGT WERDEN, UM ZU VERHINDEN DASS ES KIPPT

- Um das Produkt korrekt zu installieren und um Risiken für Ihre Sicherheit zu verhindern, die Gebrauchsanleitung genauestens befolgen.
- Das Möbel mit den vorgesehenen Befestigungen an einer Wand befestigen.
- Schrauben und Dübel sind nicht im Lieferumfang enthalten. Passende Schrauben und Dübel verwenden.

ES

ADVERTENCIA: ESTE MUEBLE DEBE ESTAR SIEMPRE FIJO EN LA PARED PARA EVITAR QUE VUELQUE

- Para instalar correctamente este producto y eliminar los riesgos para la seguridad, seguir exactamente las instrucciones del manual.
- Fijar el mueble a la pared con las sujeciones previstas a este efecto.
- Los tornillos y los tacos no están incluidos. Utilizar tornillos y tacos adaptados al soporte.

NL

WAARSCHUWING: MEUBEL MOET VERPLICHT AAN DE MUUR BEVESTIGD WORDEN ZODAT HET NIET KAN OMVALLEN

- Om dit product correct te installeren en alle risico's voor uw veiligheid te elimineren, gelieve de instructies in deze handleiding nauwgezet op te volgen.
- Zet het meubel vast aan de muur met de hiertoe voorziene bevestigingen.
- De schroeven en pluggen zijn niet meegeleverd. Gebruik schroeven en pluggen die geschikt zijn voor het materiaal van de muur.

IT

AVVERTENZA: MOBILE DA FISSARE IMPERATIVAMENTE AL MURO PER EVITARE CHE SI RIBALTI

- Per installare correttamente questo prodotto ed eliminare i rischi per la vostra sicurezza, si prega di seguire esattamente il manuale d'istruzioni.
- Fissare il mobile al muro con gli appositi ganci.
- Le viti e i tasselli non sono forniti. Utilizzare viti e tasselli adatti al supporto.

PT

ADVERTÊNCIA: MÓVEL A FIXAR OBRIGATORIAMENTE À PAREDE PARA EVITAR A SUA QUEDA

- Para instalar corretamente este produto e eliminar os riscos para a sua segurança, é favor seguir exatamente este manual de instruções.
- Fixe o móvel à parede com as fixações previstas para o efeito
- Os parafusos e as cavilhas não são fornecidos. Utilize parafusos e cavilhas adaptados ao suporte.

CR

UPOZORENJE : UČVRSTITE ORMARIĆ NA ZID KAKO BISTE SPRIJEČILI NJEGOVO LJULJANJE

- Kako biste pravilno postavili ovaj proizvod i uklonili sigurnosne rizike kojima se izlažete, pridržavajte se strogo ovog priručnika s uputama.
- Postavite ormarić na zid pripadajućim sponama.Vijci i svornjci ne isporučuju se. Upotrijebite nosne vijke i svornjke.

Hu

FIGYELEM: A BÚTORT FELTÉTENÜL RÖGZÍTENI KELL A FALHOZ, HOGY ELKERÜLJE A FELBILLENÉSÉT

- A termék megfelelő elhelyezéséhez és a biztonságot érintő kockázatok kiküszöböléséhez pontosan kövesse ezt a használati útmutatót.
- Rögzítse a bútort a falhoz az erre a célra szolgáló rögzítőelemekkel.
- A csavarok és a tiplik nincsenek mellékelve. Használjon a tartóhoz illő csavarokat és tipliket.

العربية:

تحذير: قطعة أثاث يلزم تثبيتها على الحائط لتجنب تأرجحها

- لتركيب هذا المنتج بشكل صحيح وتجنب المخاطر من أجل سلامتك، يرجى اتباع كتيب التعليمات هذا بالضبط.
- تثبت قطعة الأثاث على الحائط بواسطة العلاقات المخصصة لهذا الغرض
- إن البراغي والخوابير غير متوفرة مع المنتج. تستخدم براغي وخوابير ملائمة للحائط الذي يتم التثبيت عليه.

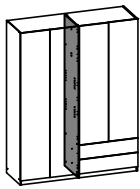

1

C x2



W x4

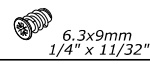

U x2

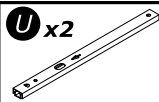

www.Demeyere.fr

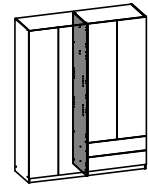
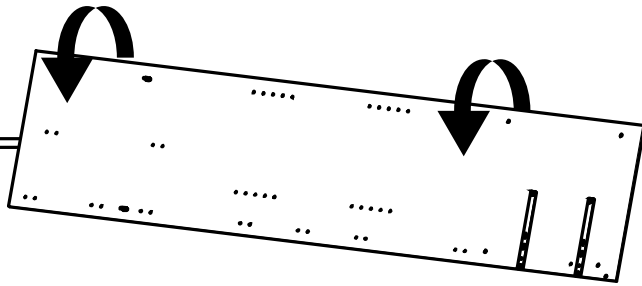
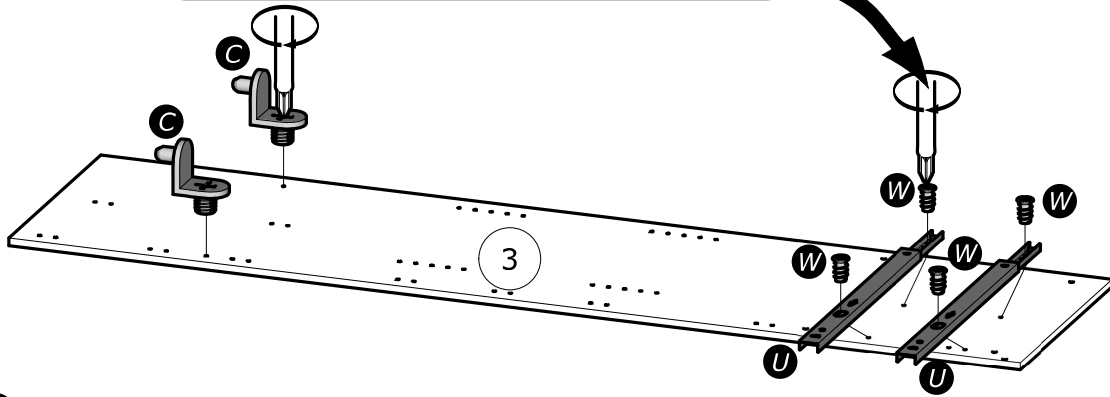
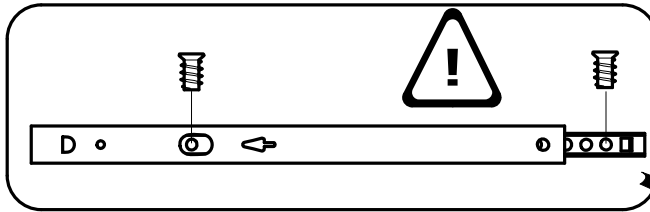

2

K x1

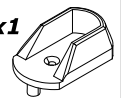

C x2

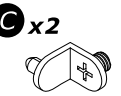

F x1

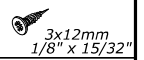

M x1

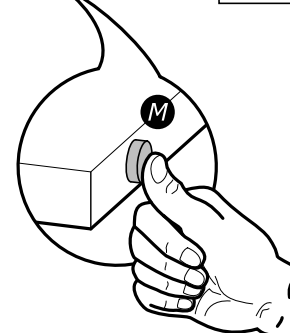
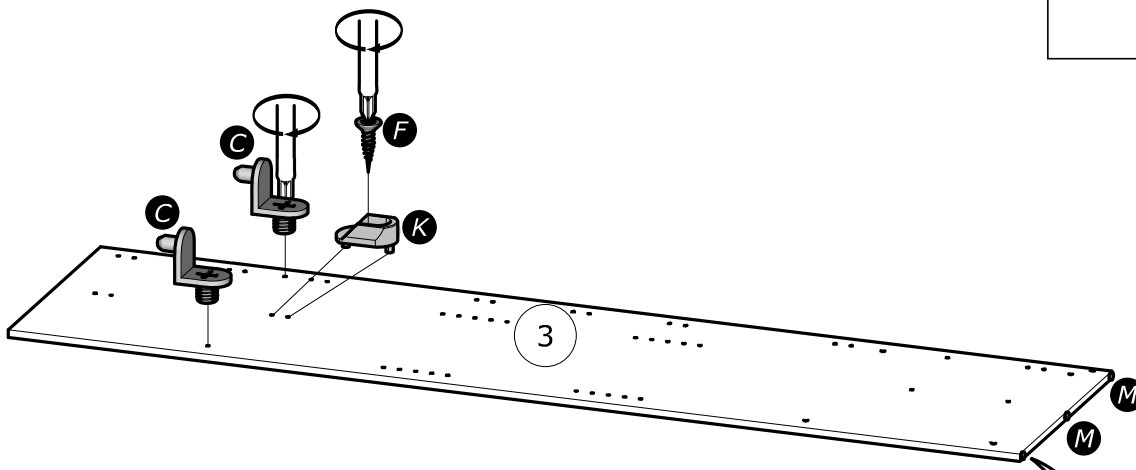
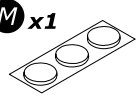

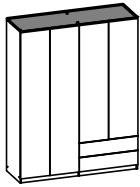

3

A

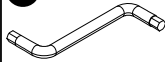

Q

x2

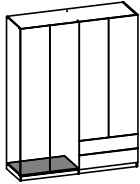
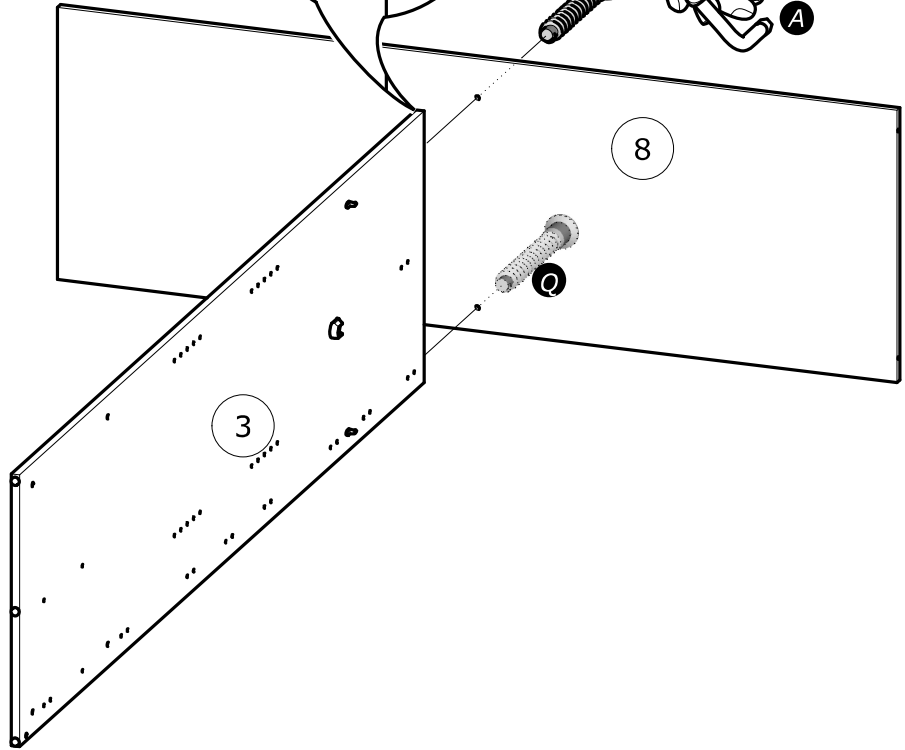
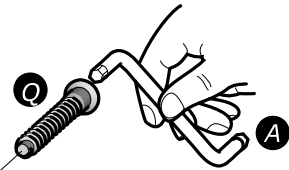
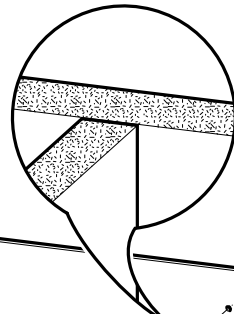
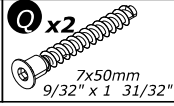

4

A

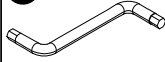

Q

x2

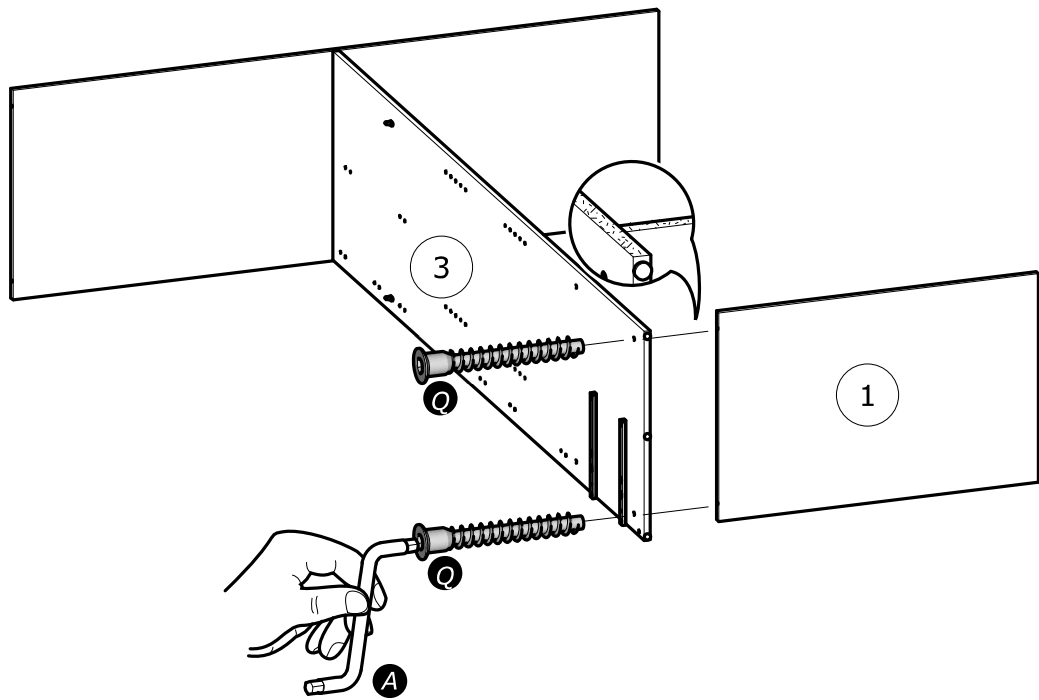
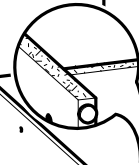
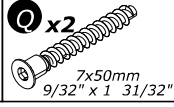

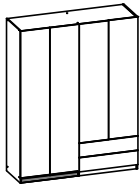

5

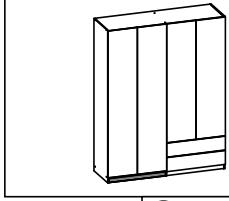
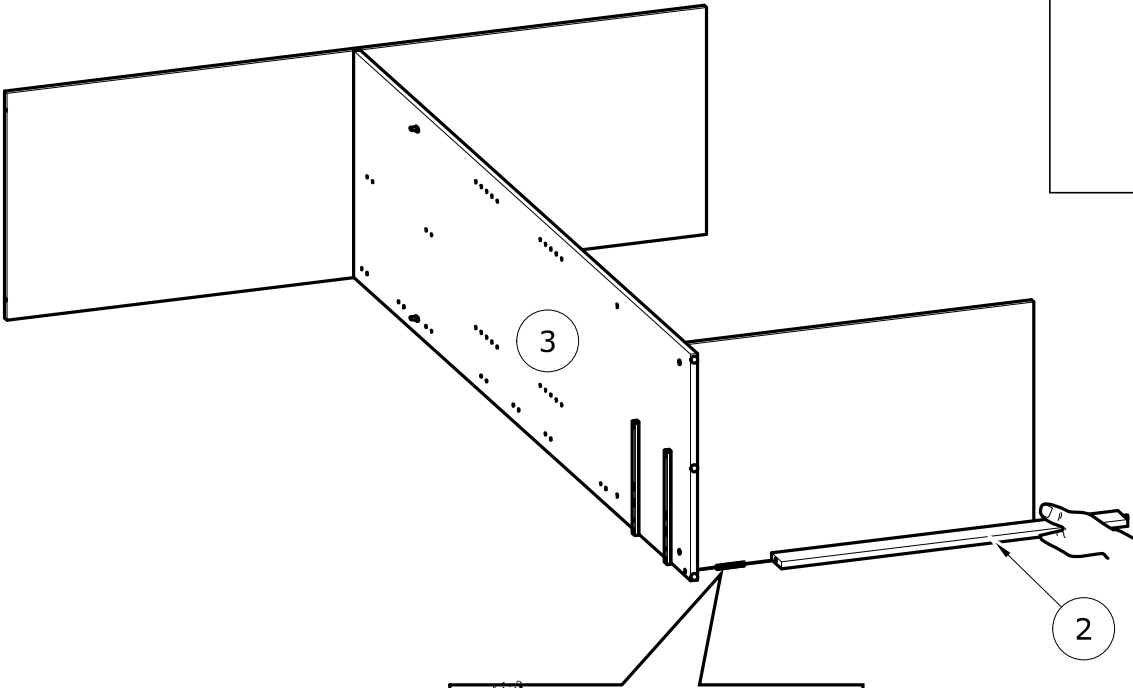
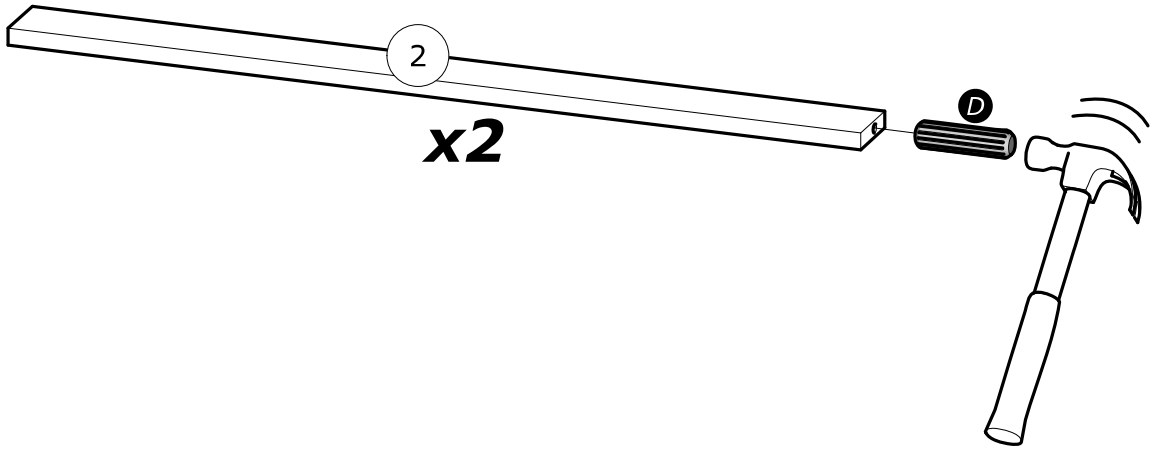
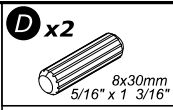

6

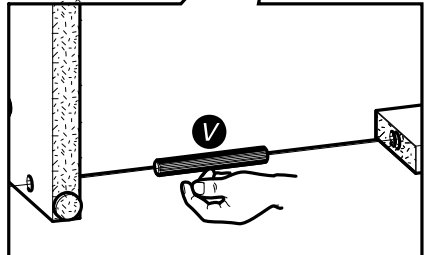
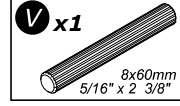

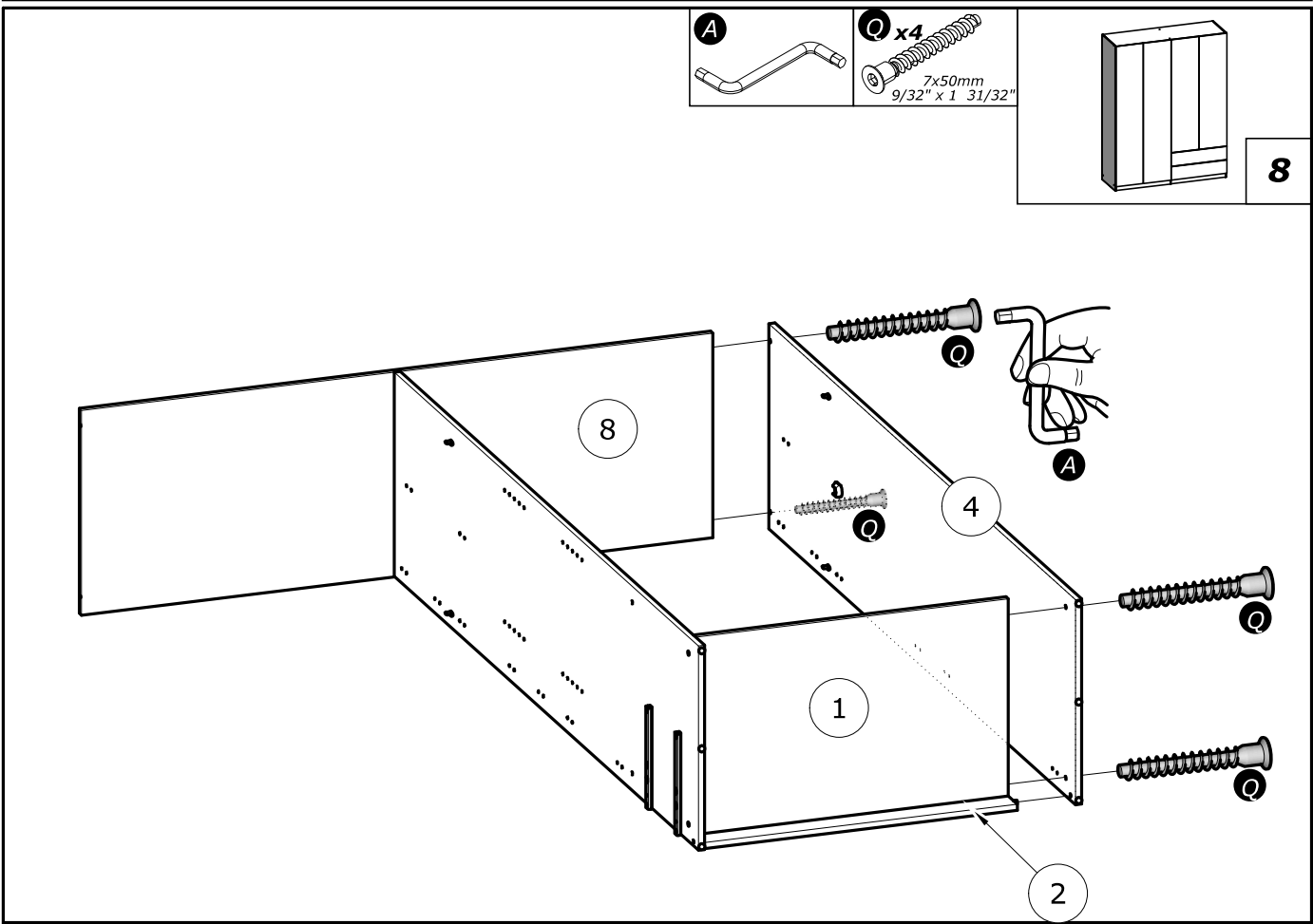
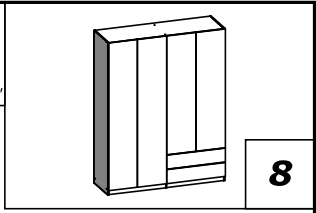
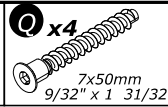
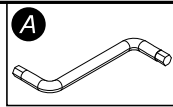
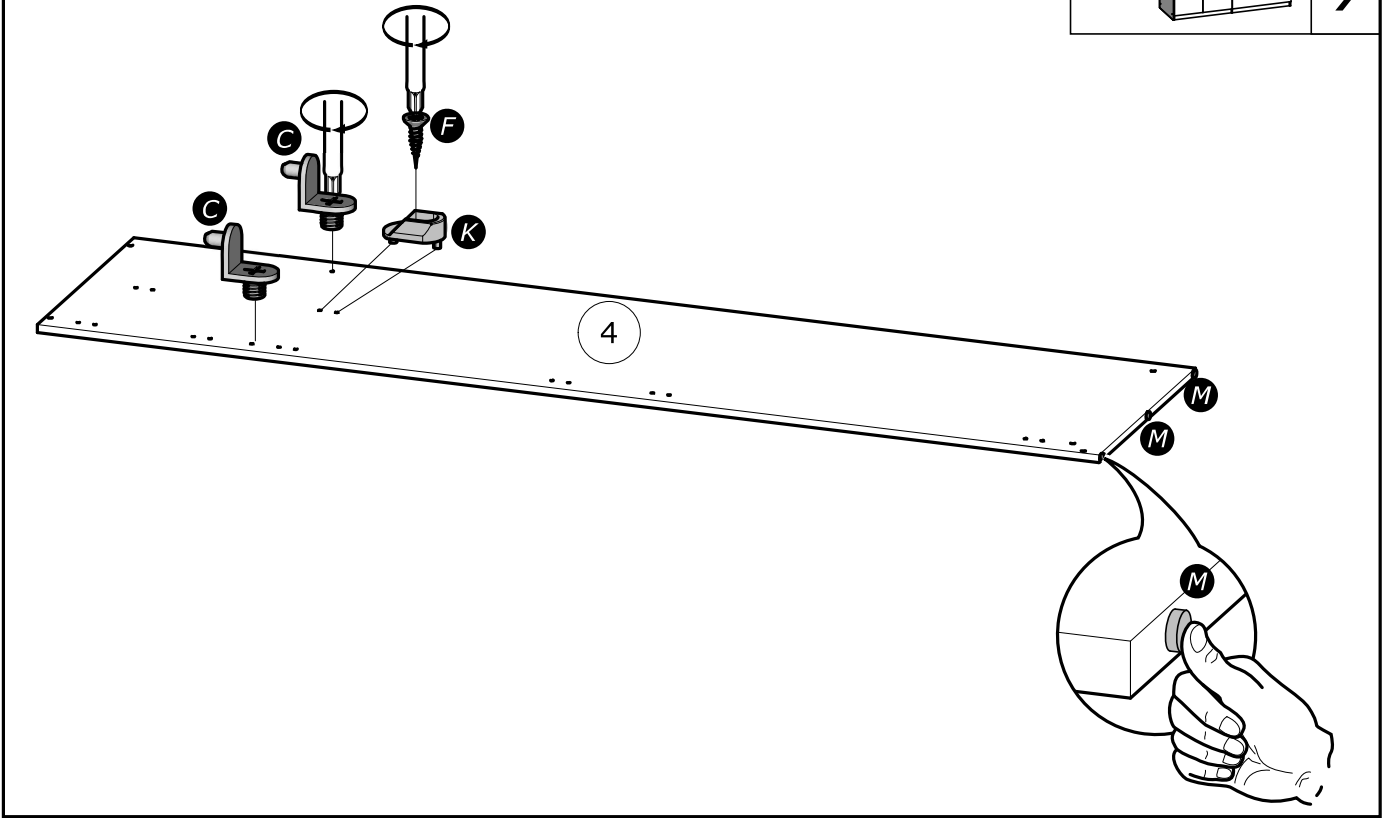
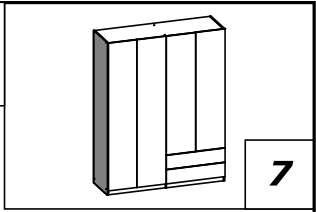
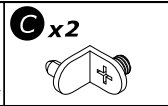
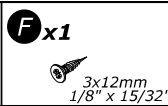
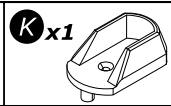
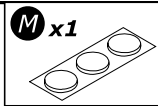

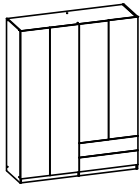

9

E x4
3x12mm
1/8" x 15/32"

B x1

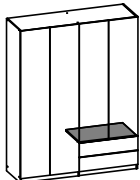
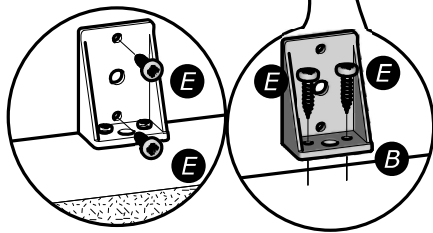
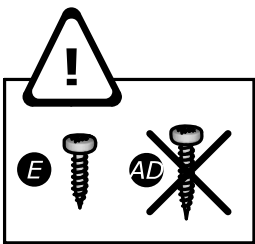
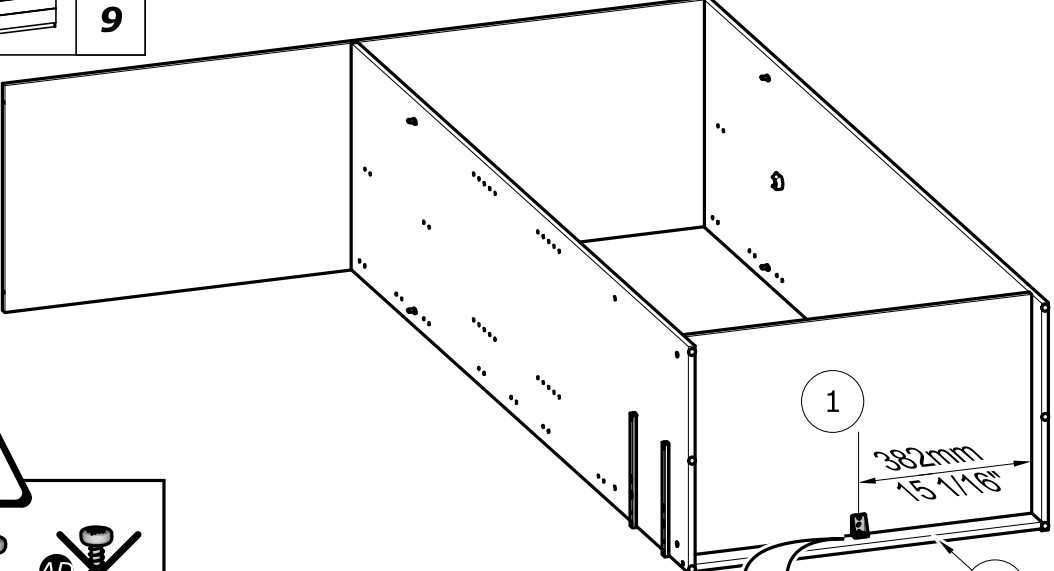

10

Q x2
7x50mm
9/32" x 1 31/32"

A

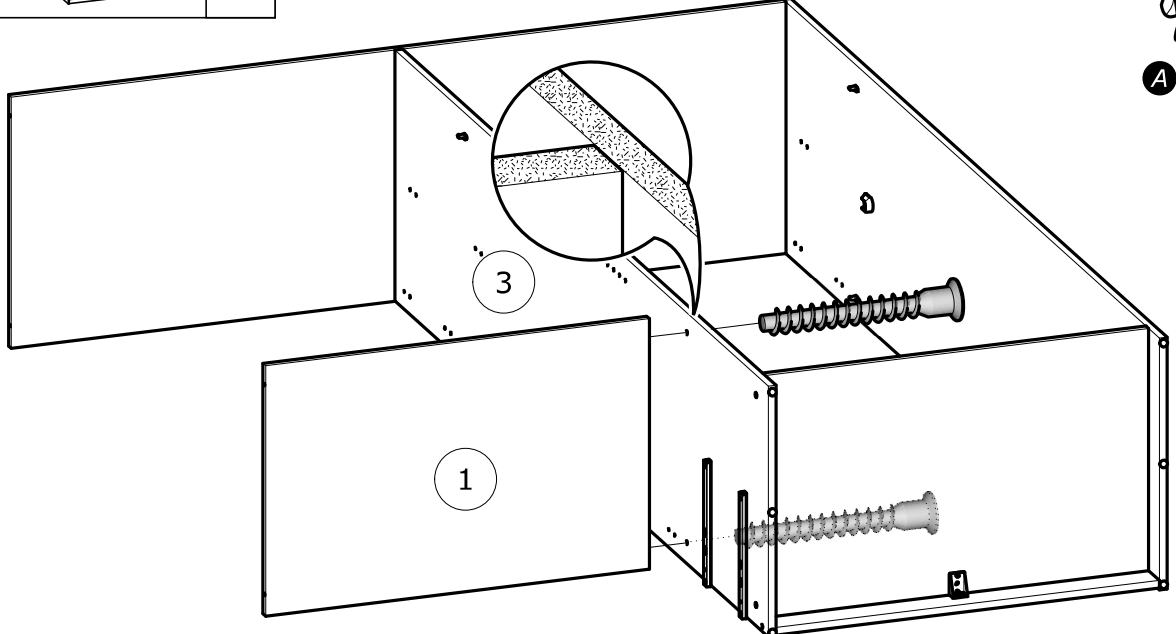
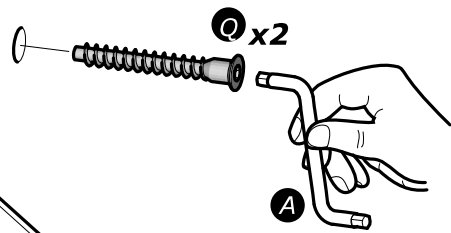

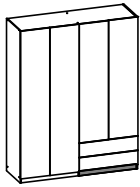

11

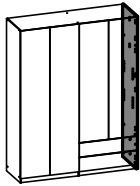
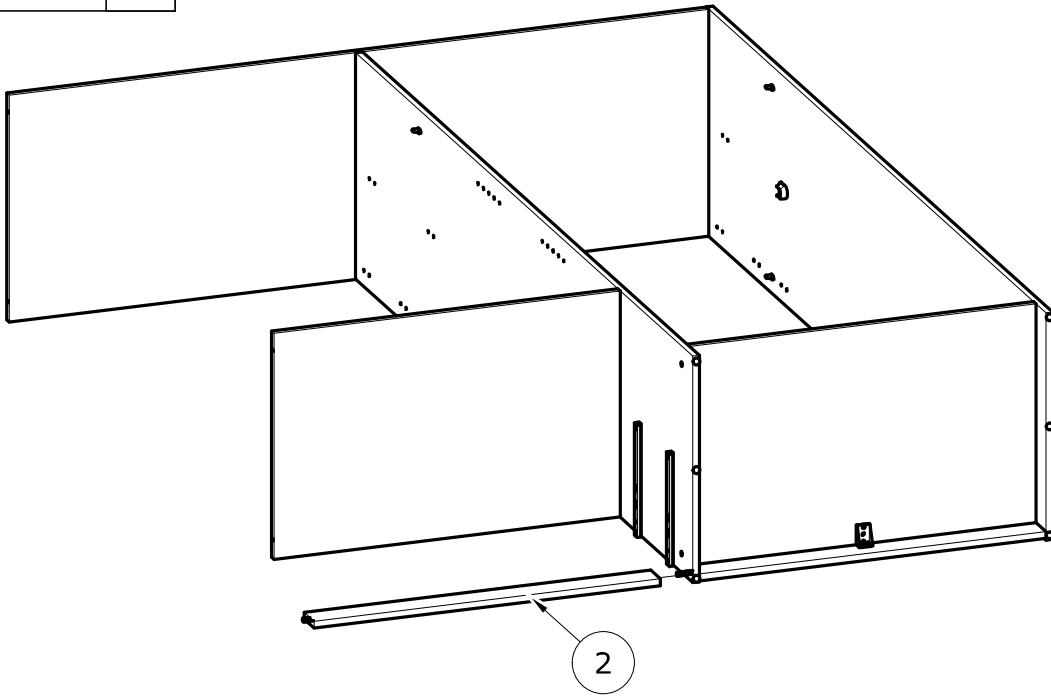

12

- C** x2
- W** x4
6.3x9mm
1/4" x 11/32"
- U** x2
- M** x1

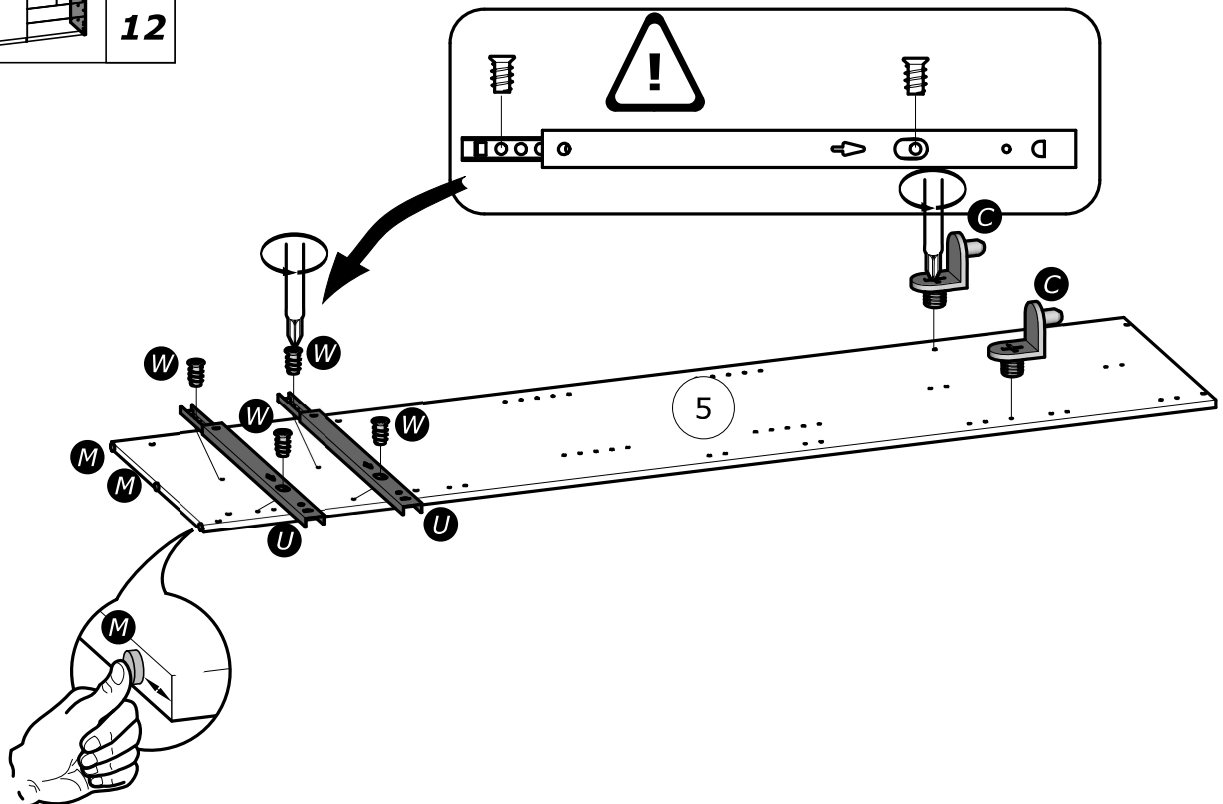

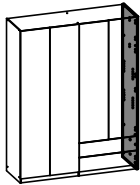

13

Q x4
7x50mm
9/32" x 1 31/32"

A

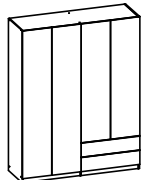
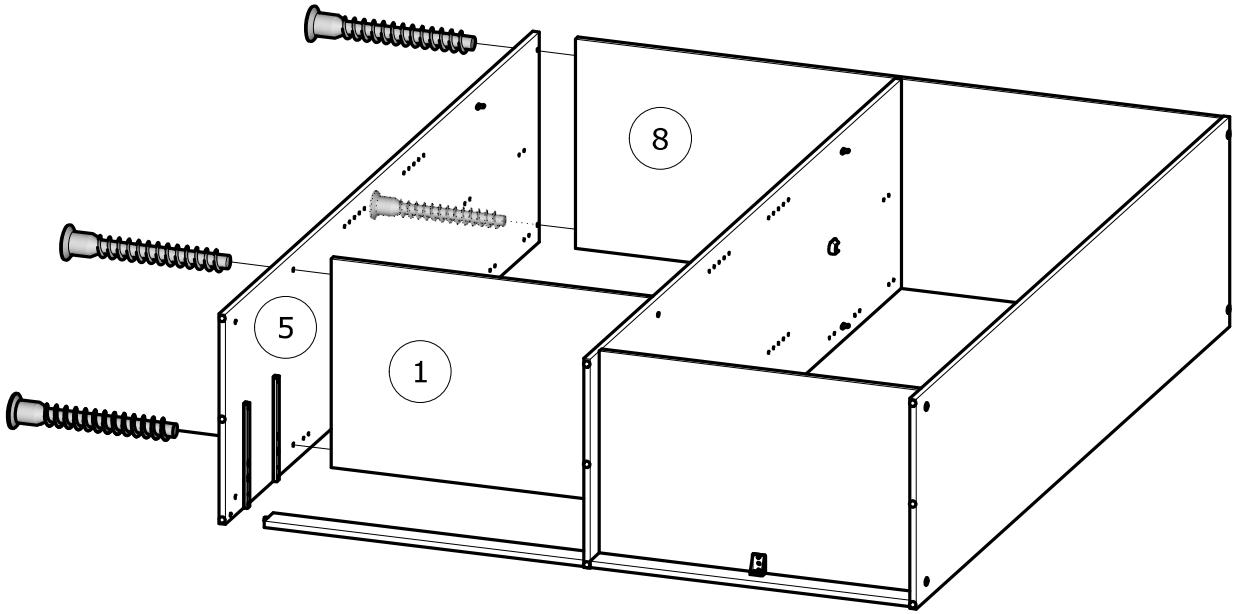
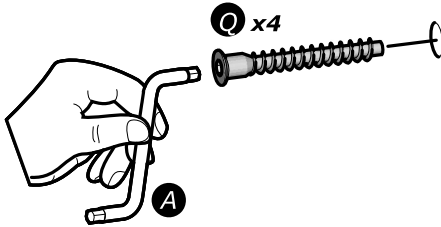

14

E x4
3x12mm
1/8" x 15/32"

B x1

E

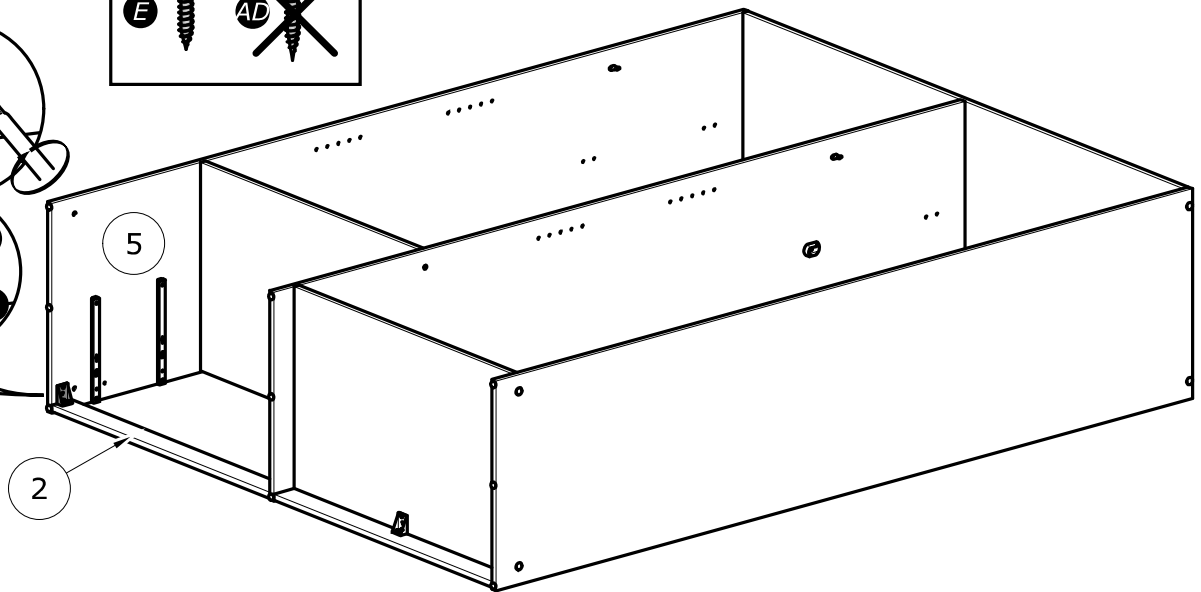
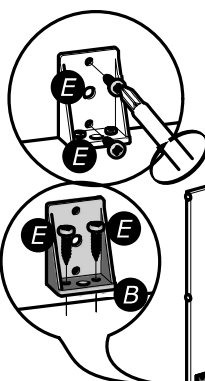

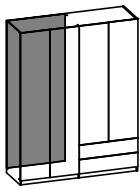

15

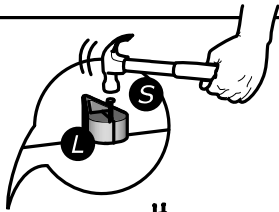
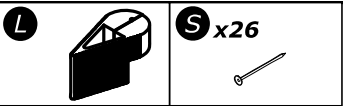

www.Demeyere.fr

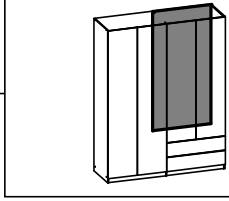
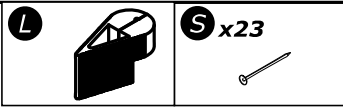
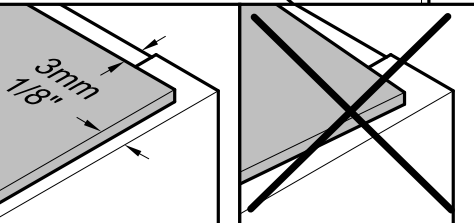
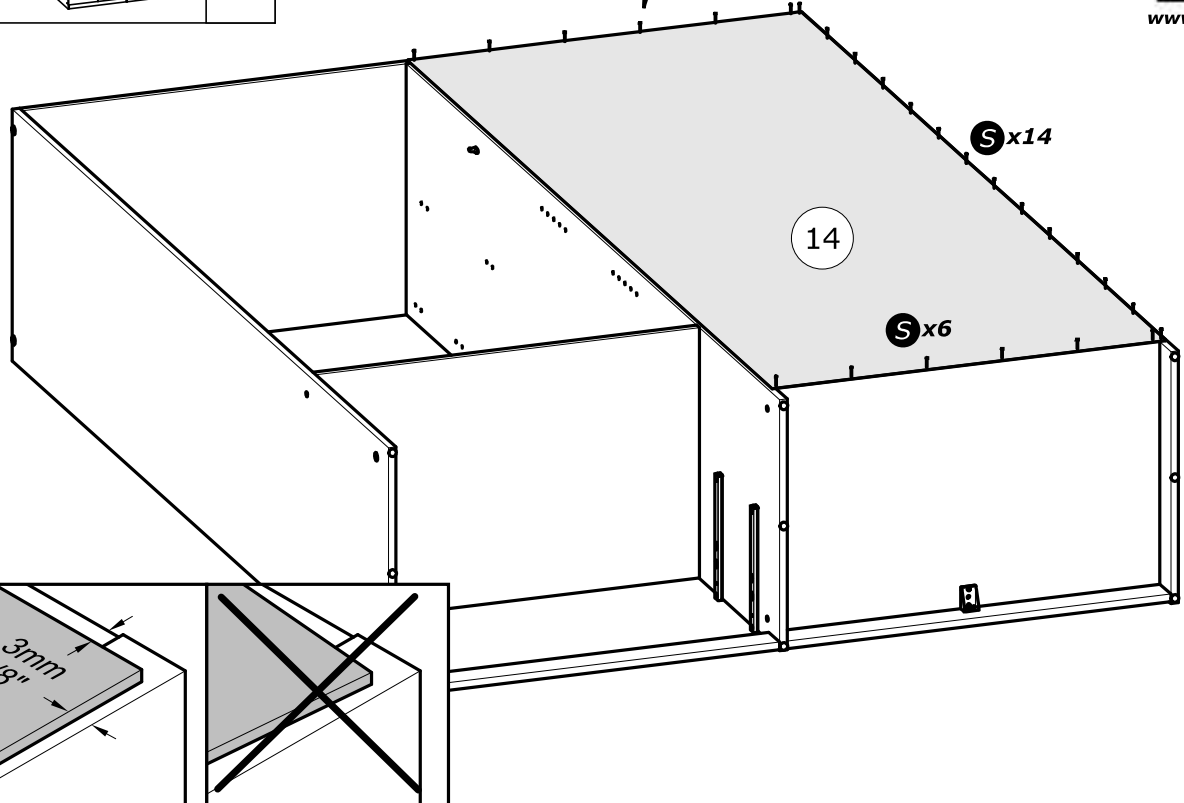

16

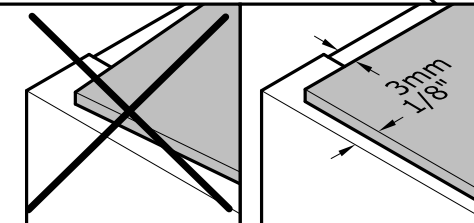
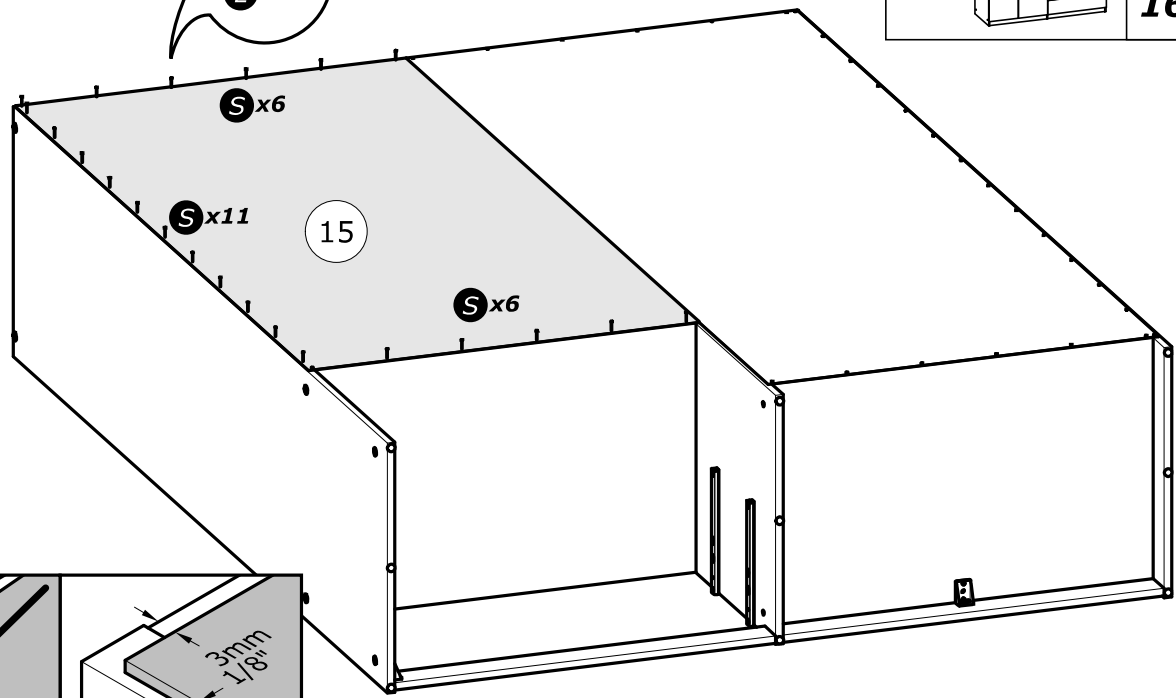
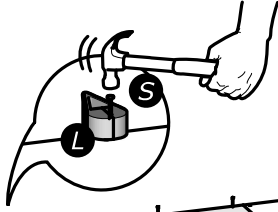

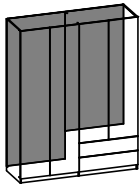

17

X x8

3x16mm
1/8" x 5/8"

44 x8

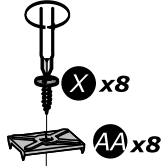

X x8

44 x8

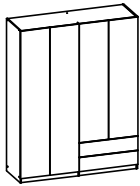
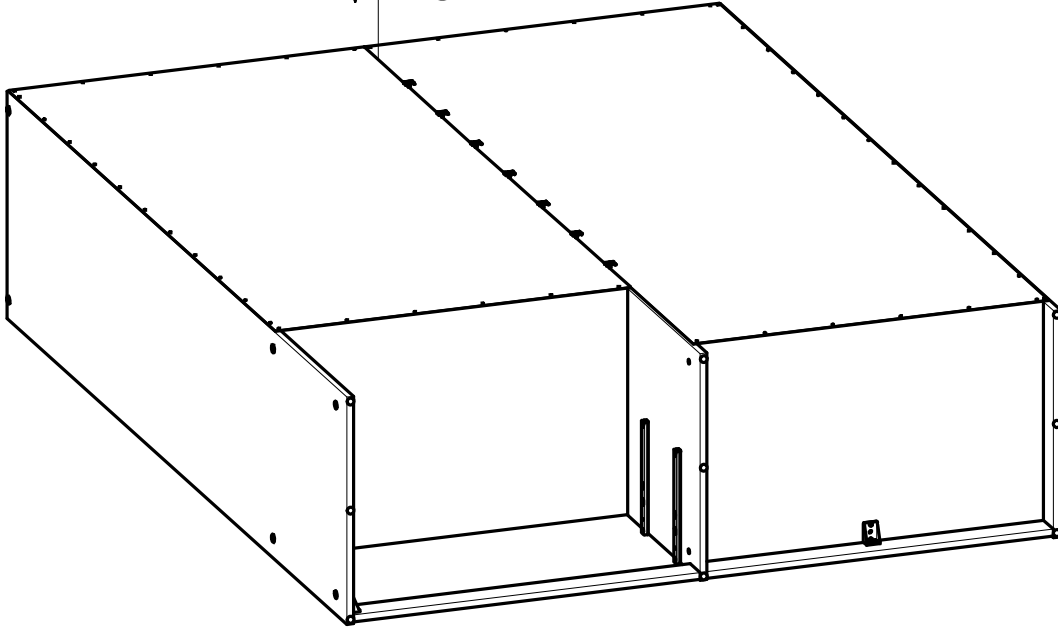

18



x2

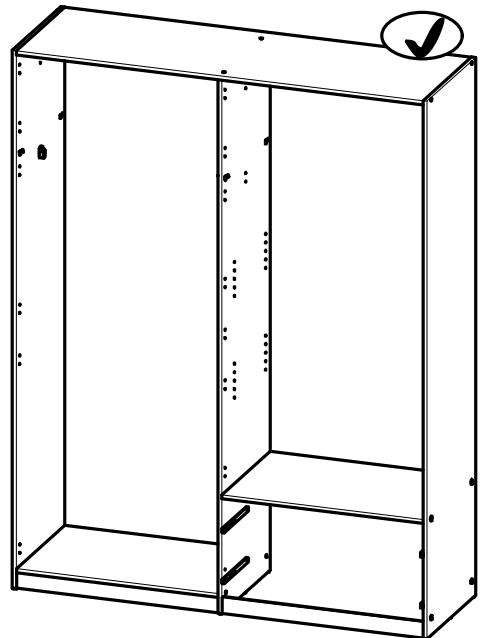
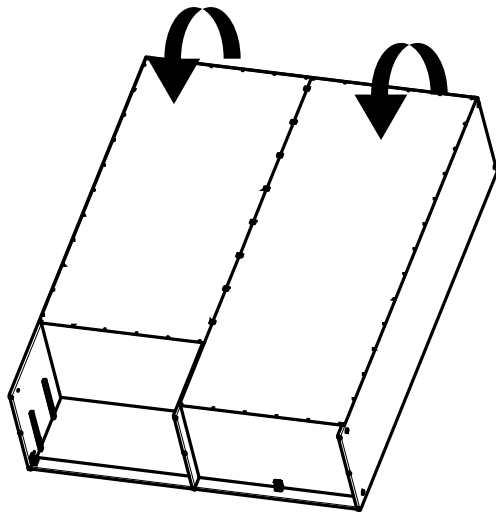

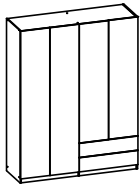

19

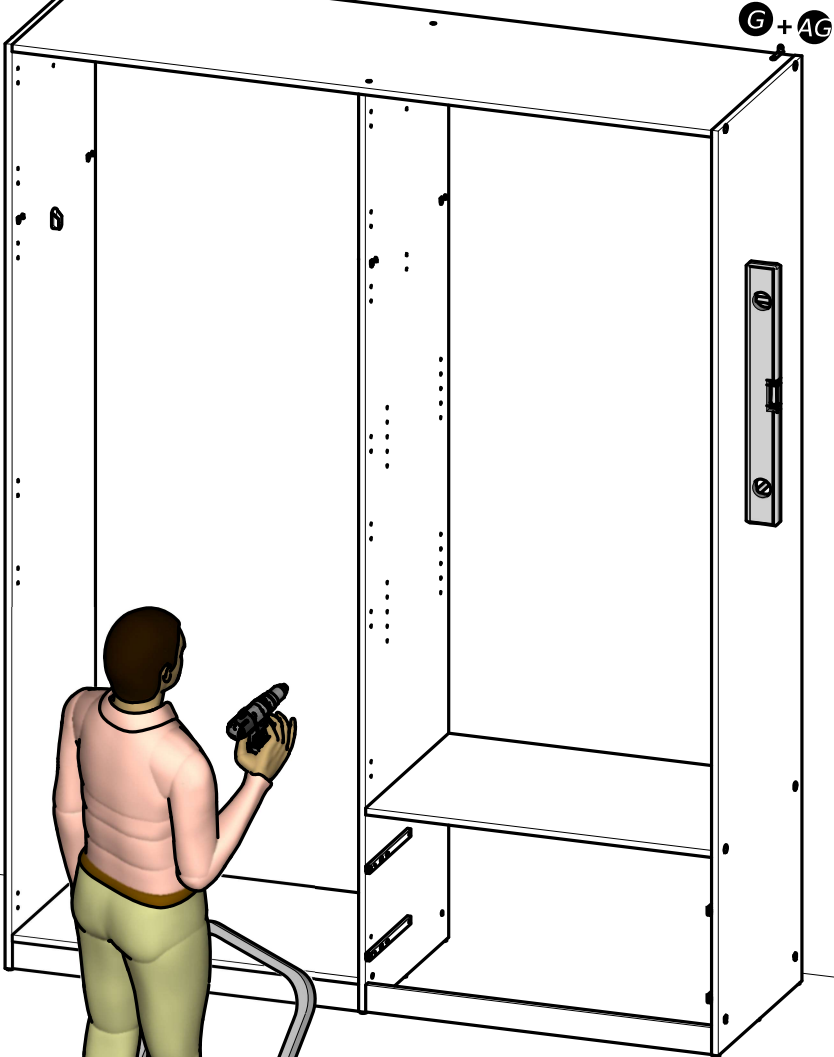
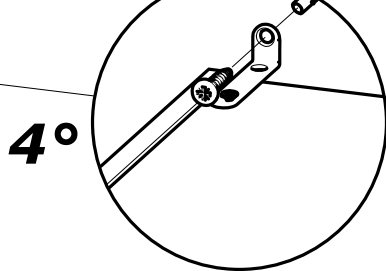
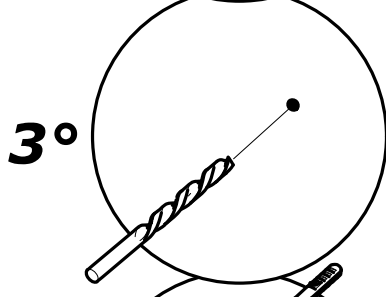
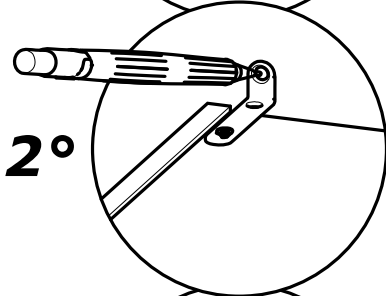
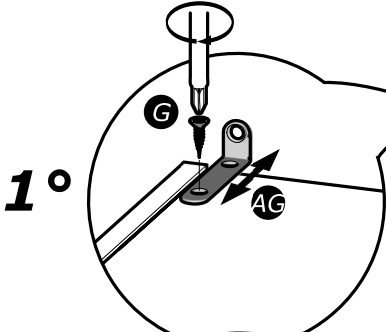

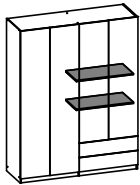

22

R x2  **AE** x8 

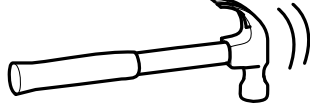
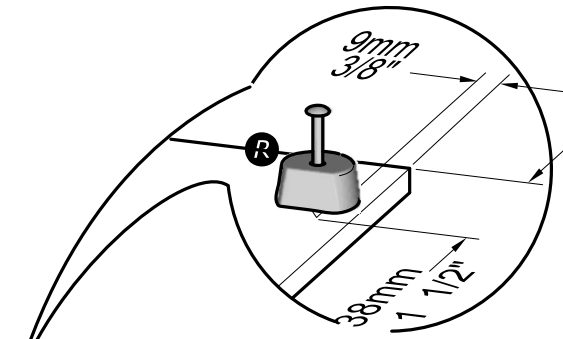

9 x2  **R** x2

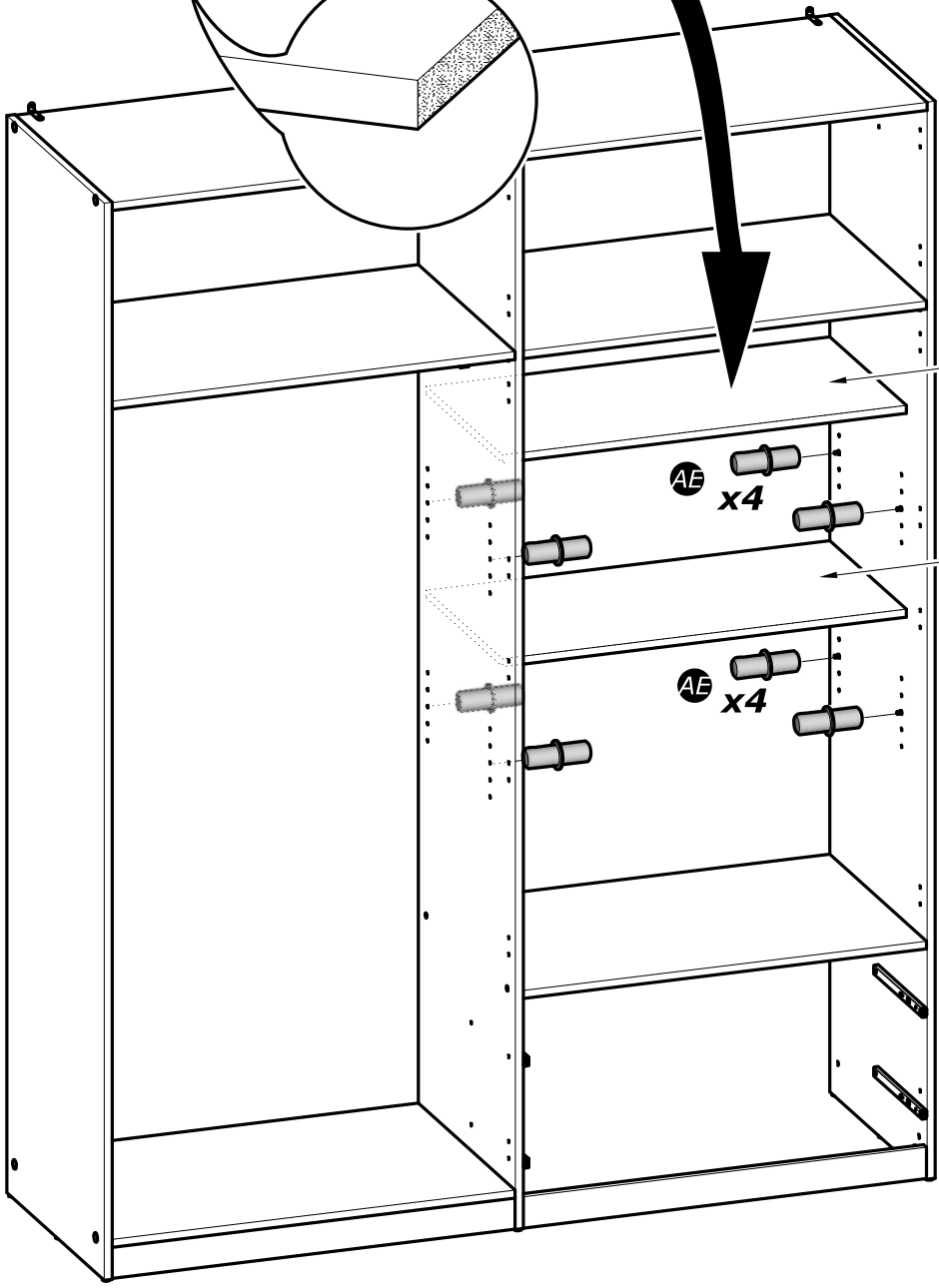
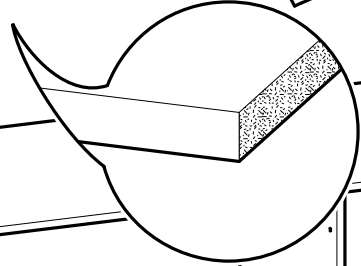

9

AE x4

9

AE x4

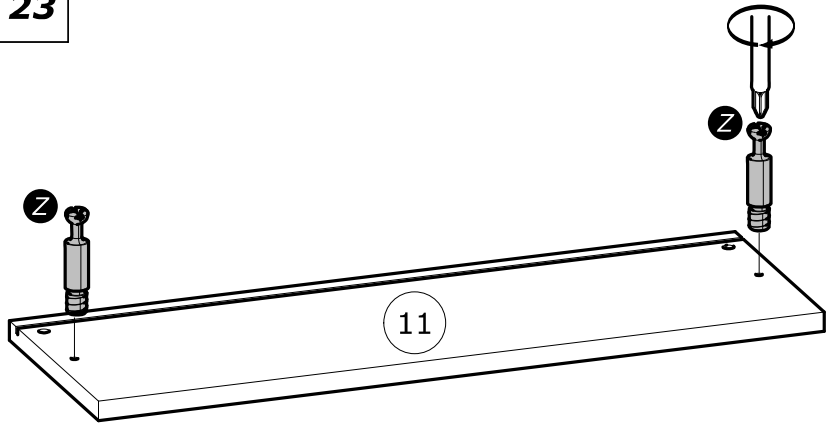
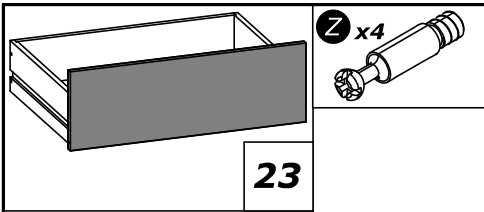

x2

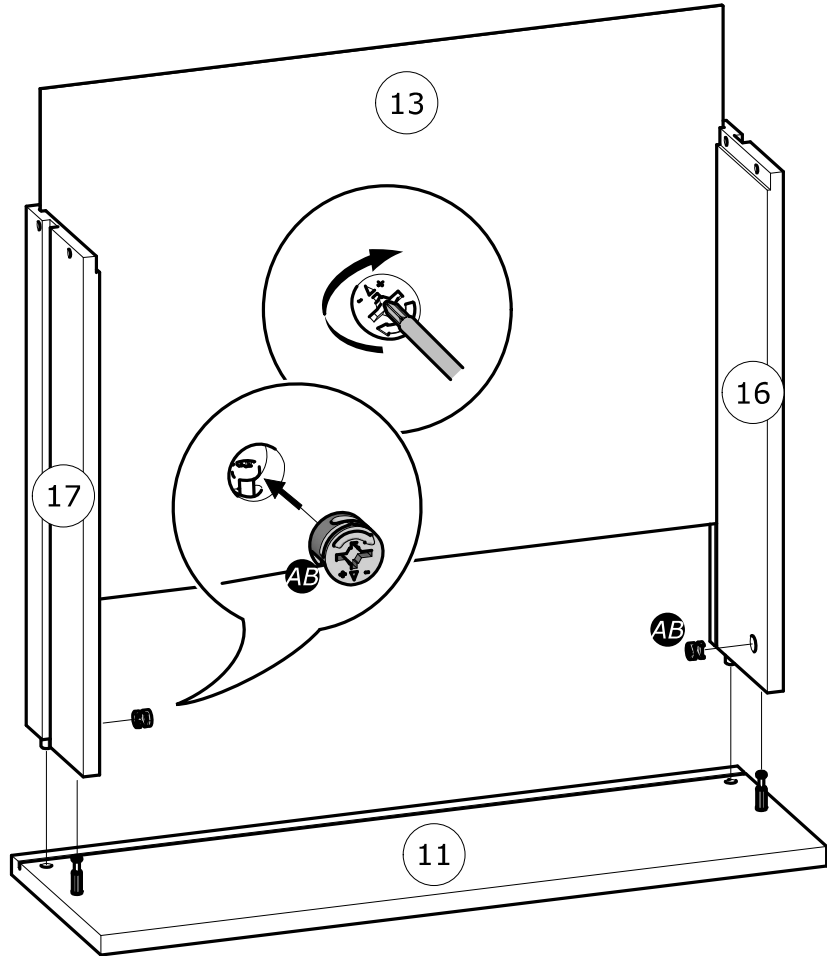
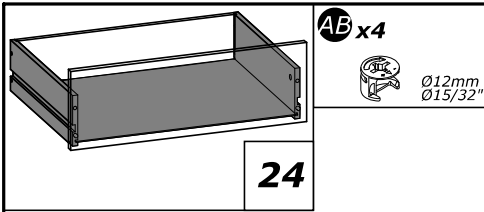

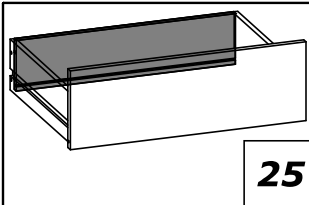

25

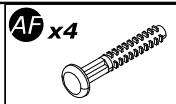

AF x4

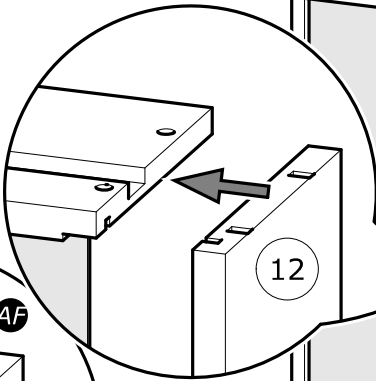
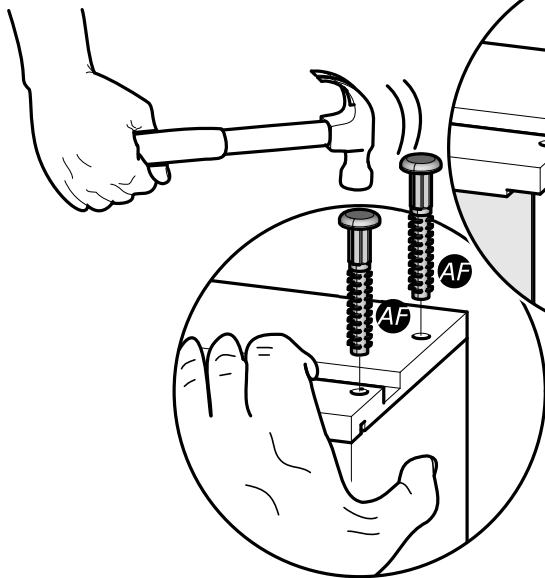

12

12

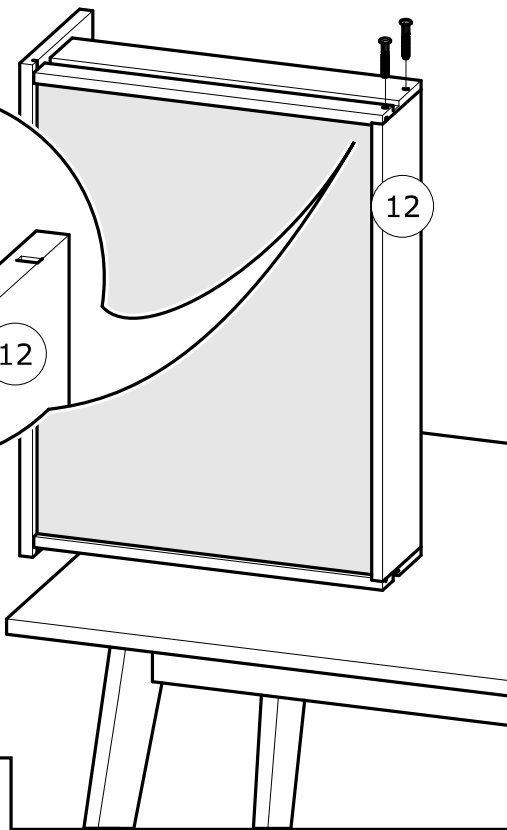

x2

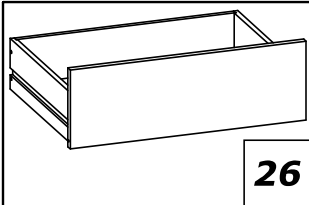

26

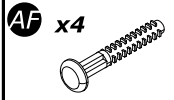

AF x4

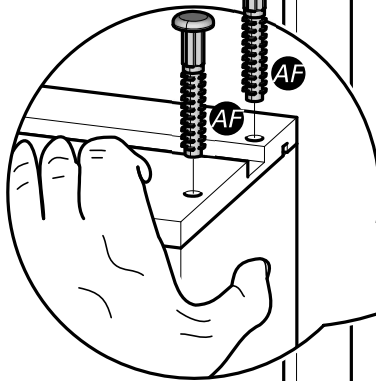
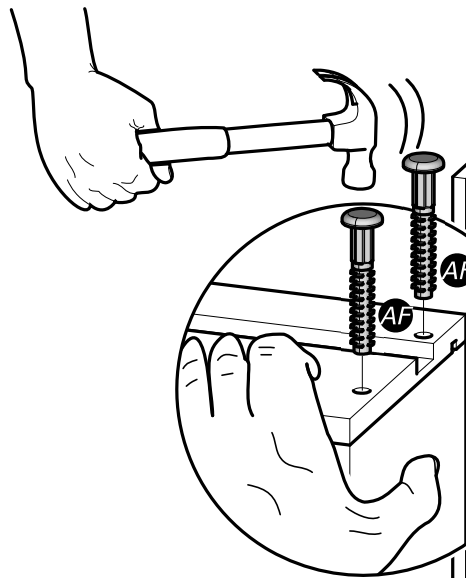

12

12

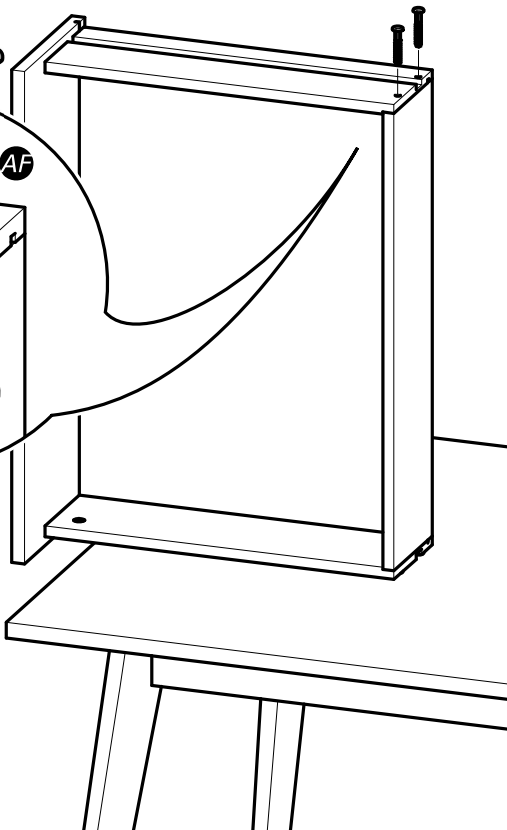
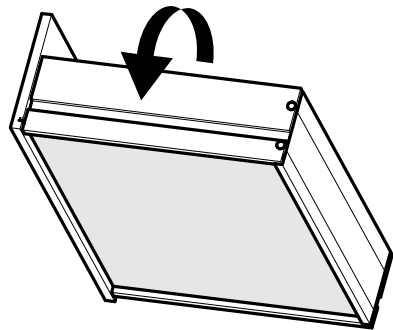



27

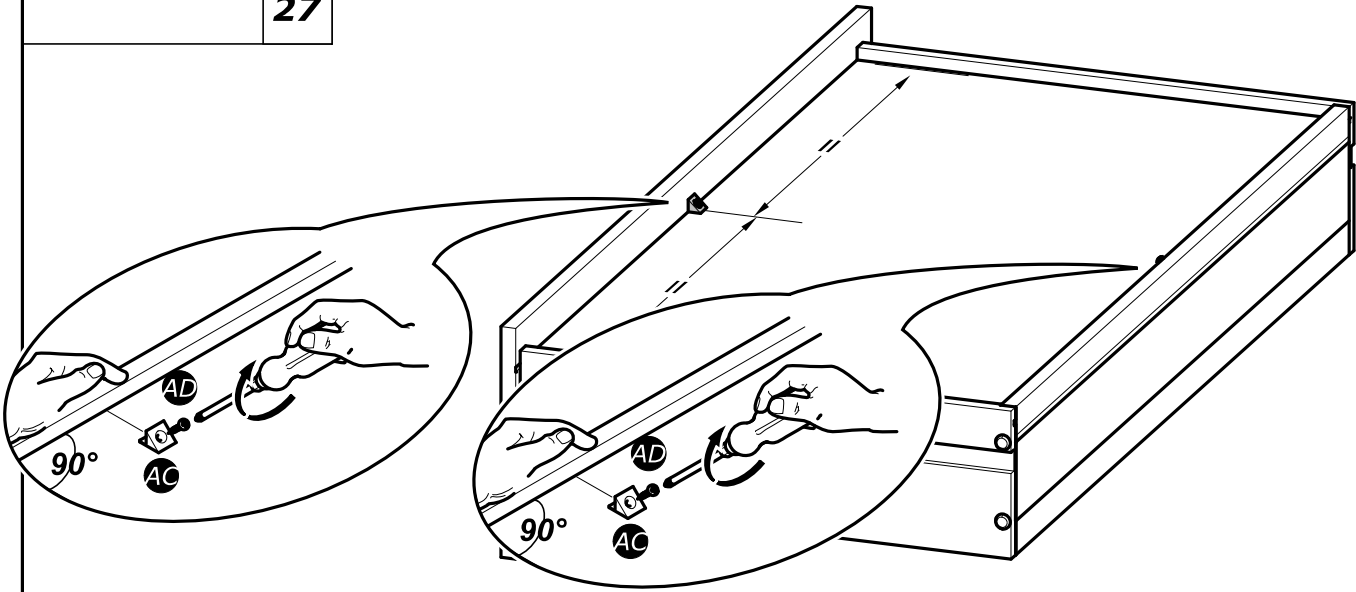
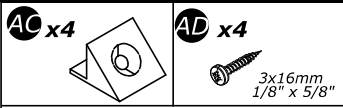

x2



28

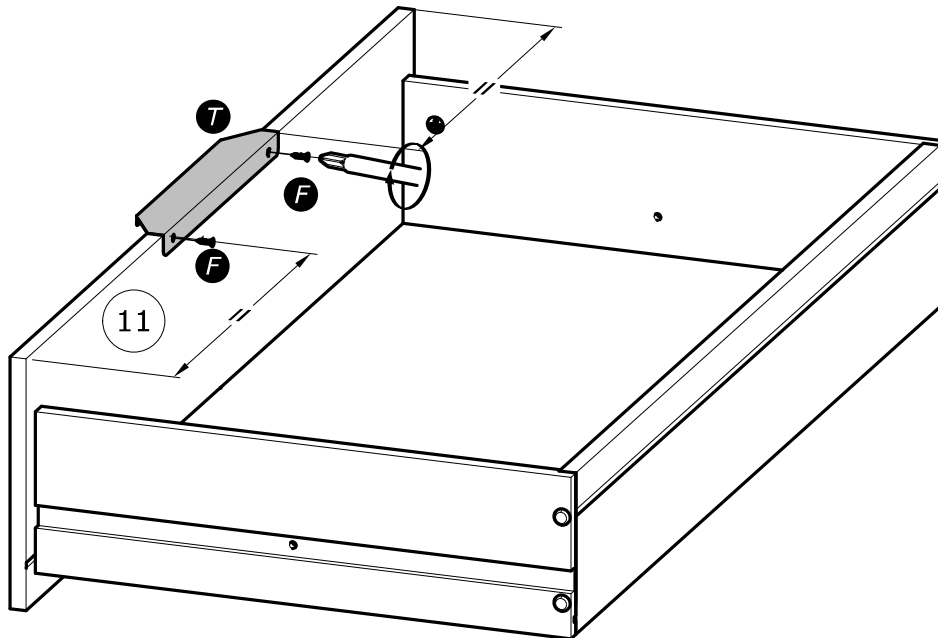
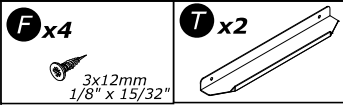

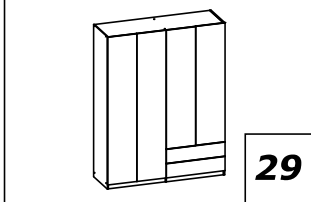
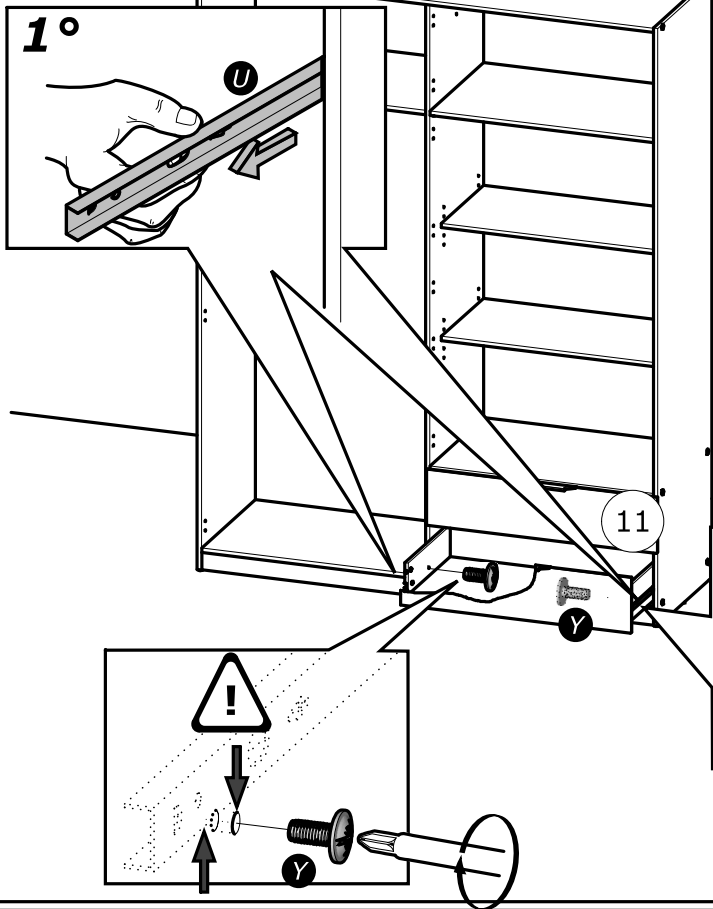

Y x4
 4x9mm
 5/32" x 11/32"

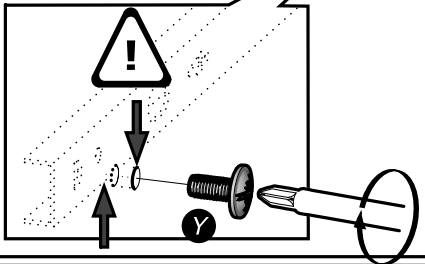
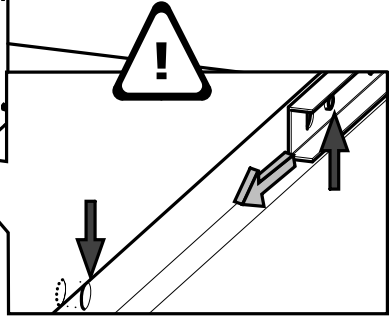

O x6
N x6
 H=2mm
 H=1/16"

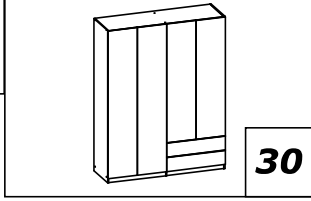

www.Demeyere.fr

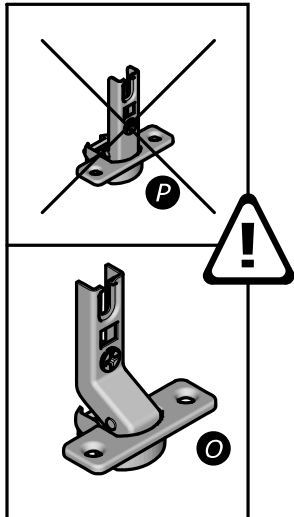
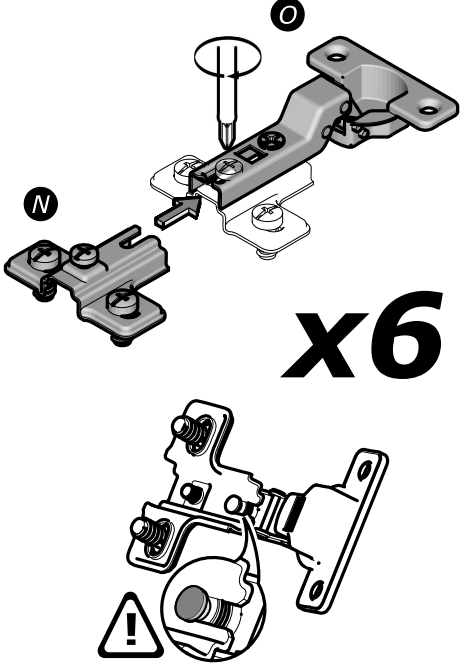

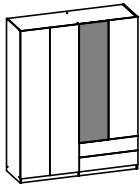

31

F x6

3x12mm
1/8" x 15/32"

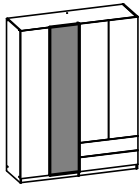
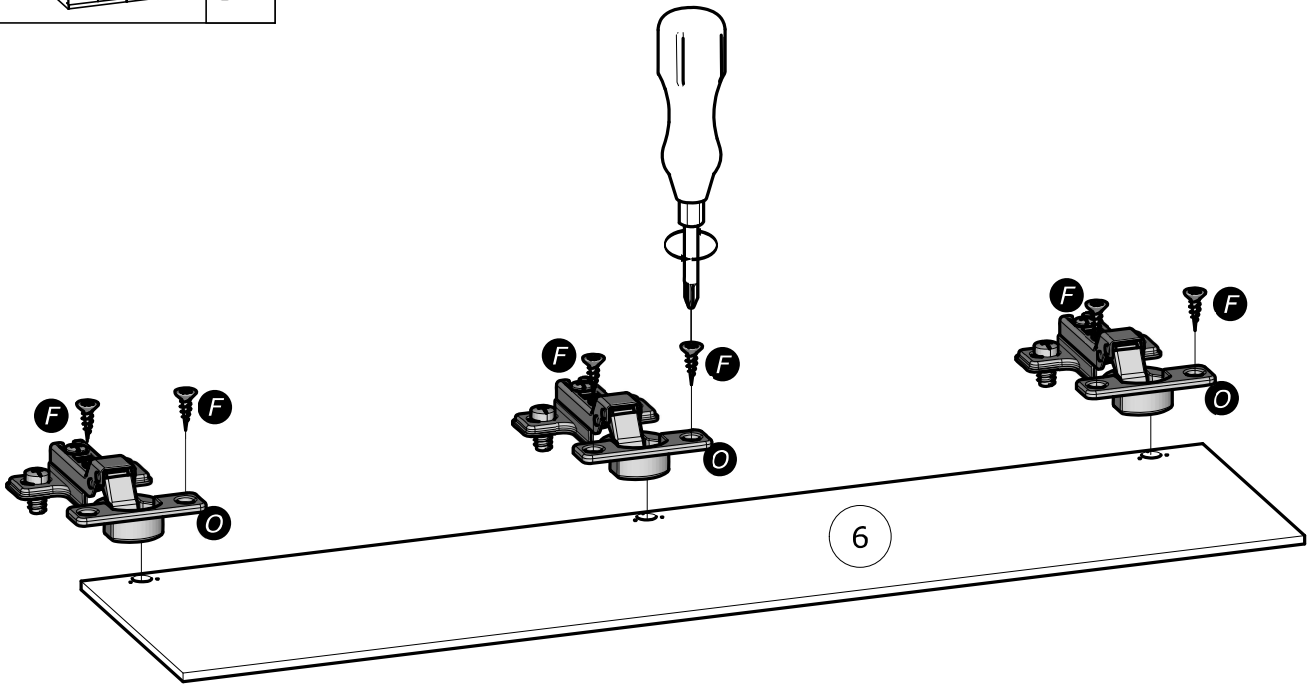

32

F x6

3x12mm
1/8" x 15/32"

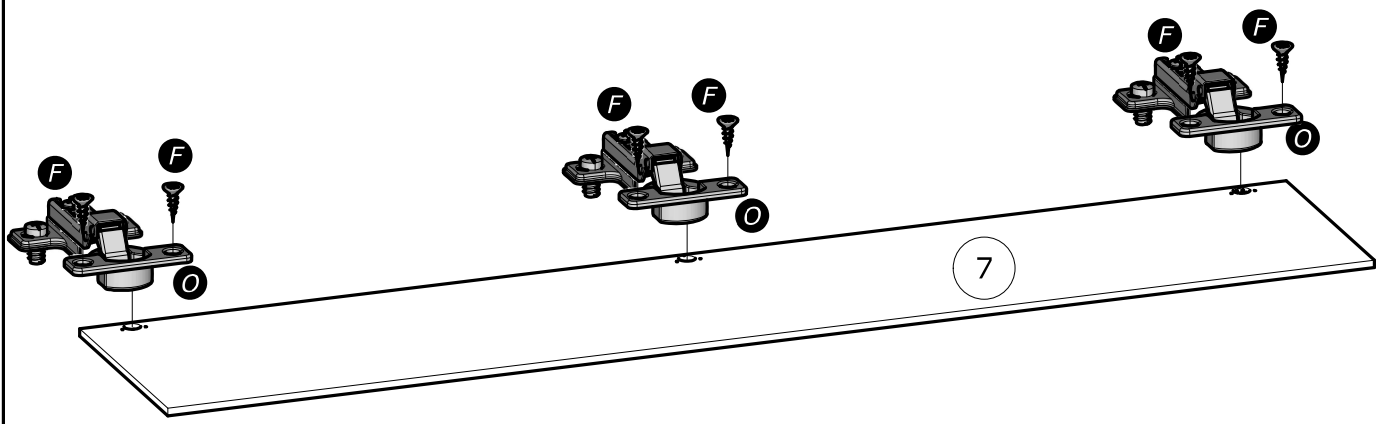

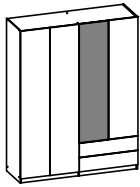

33

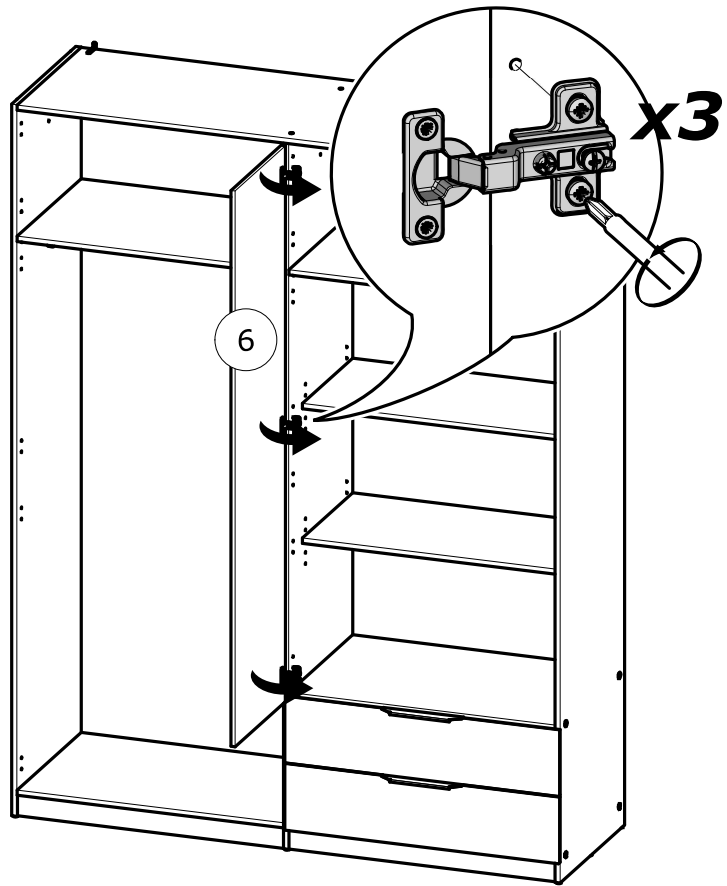

6

x3

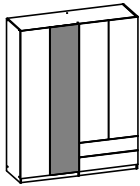

34

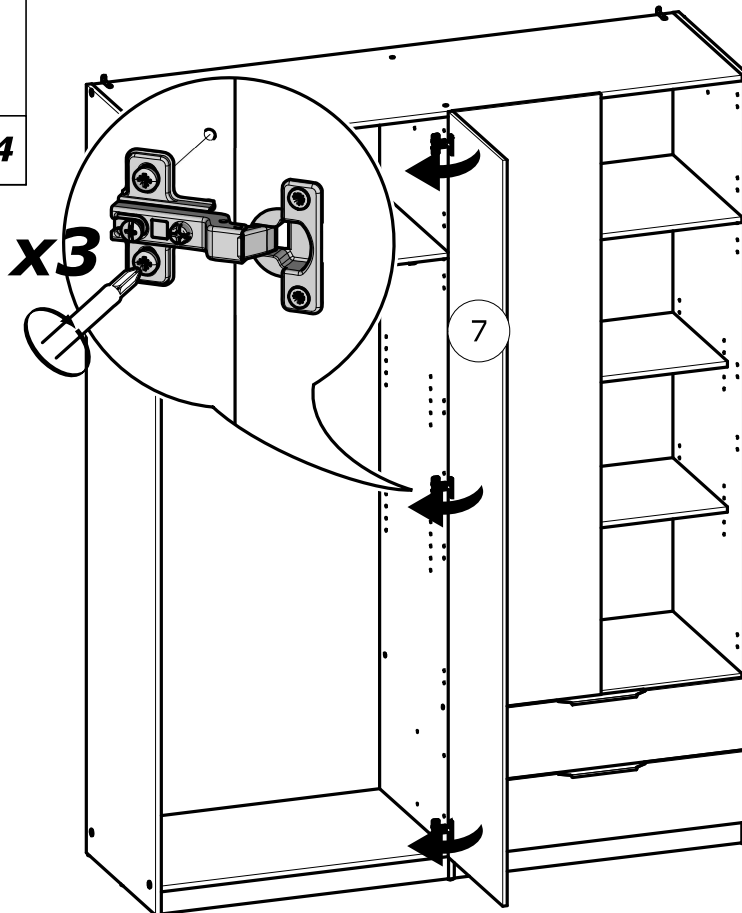

7

x3

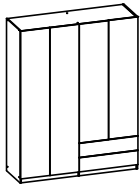

35

N x6

H=2mm
H=1/16"



P x6

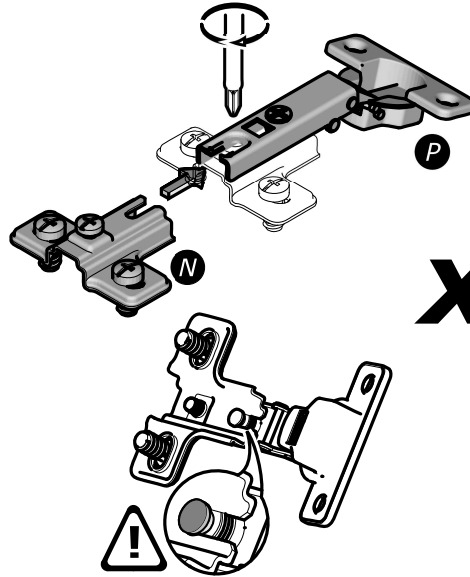
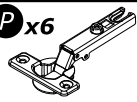

x6

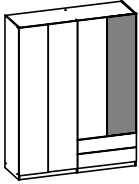

36

F x6

3x12mm
1/8" x 15/32"

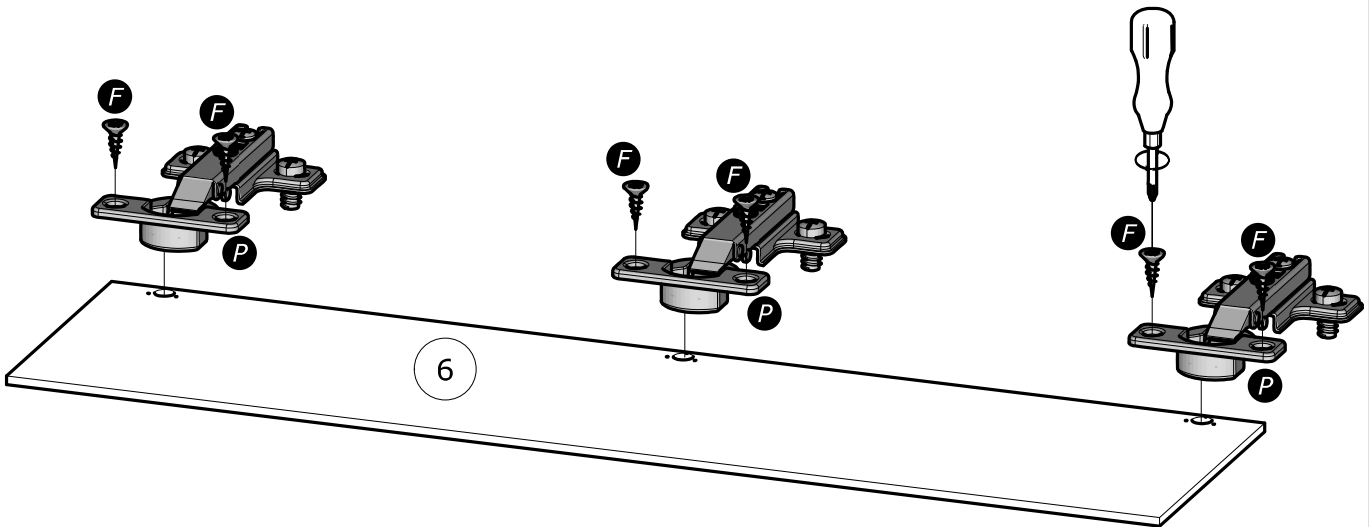

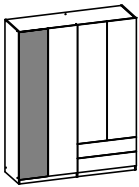

37

F x6
3x12mm
1/8" x 15/32"

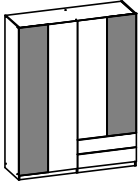
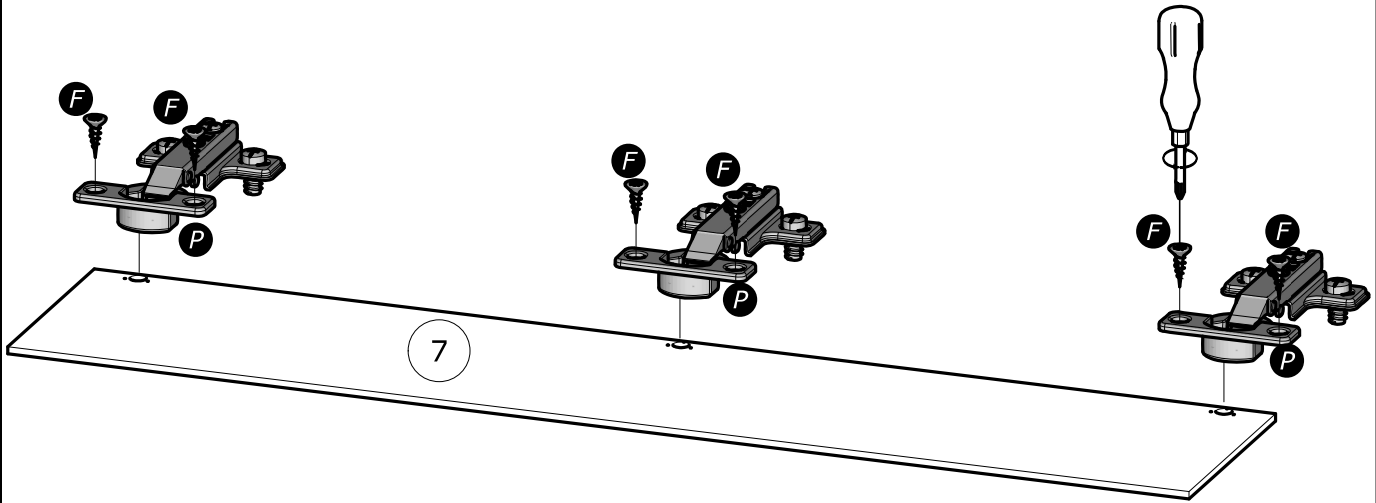

38

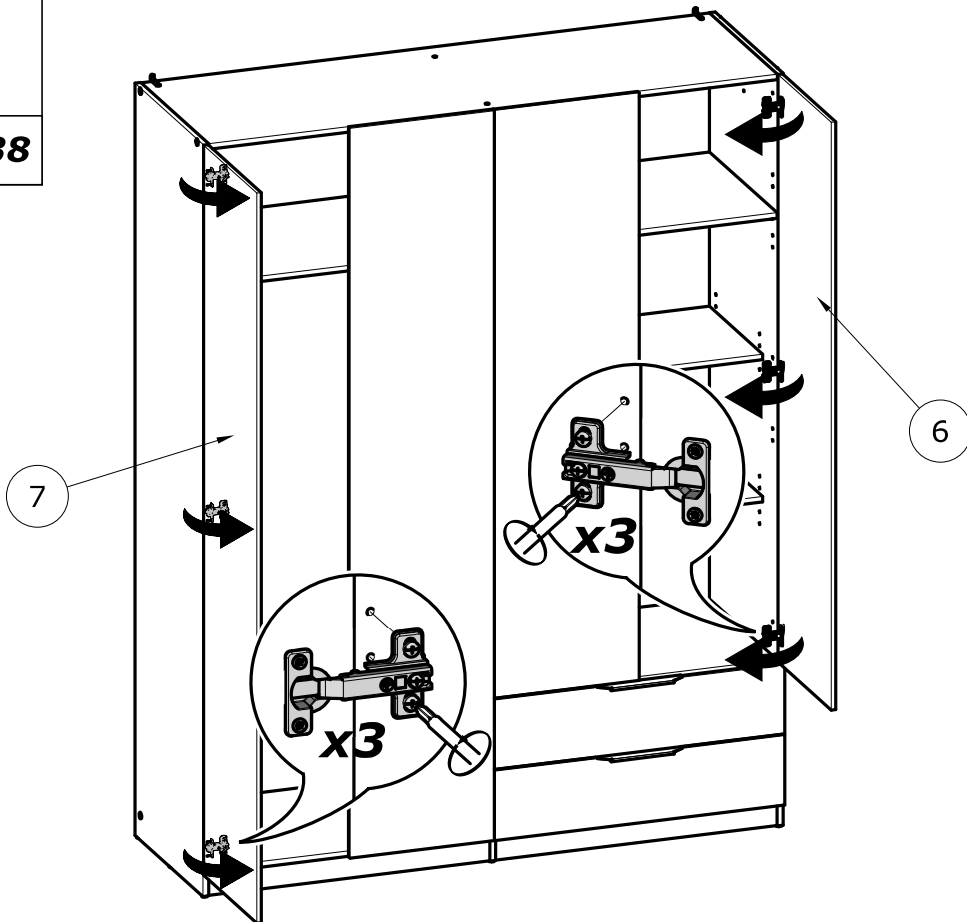

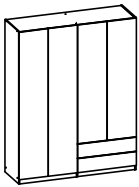

39

F x4

3x12mm
1/8" x 15/32"

T x2

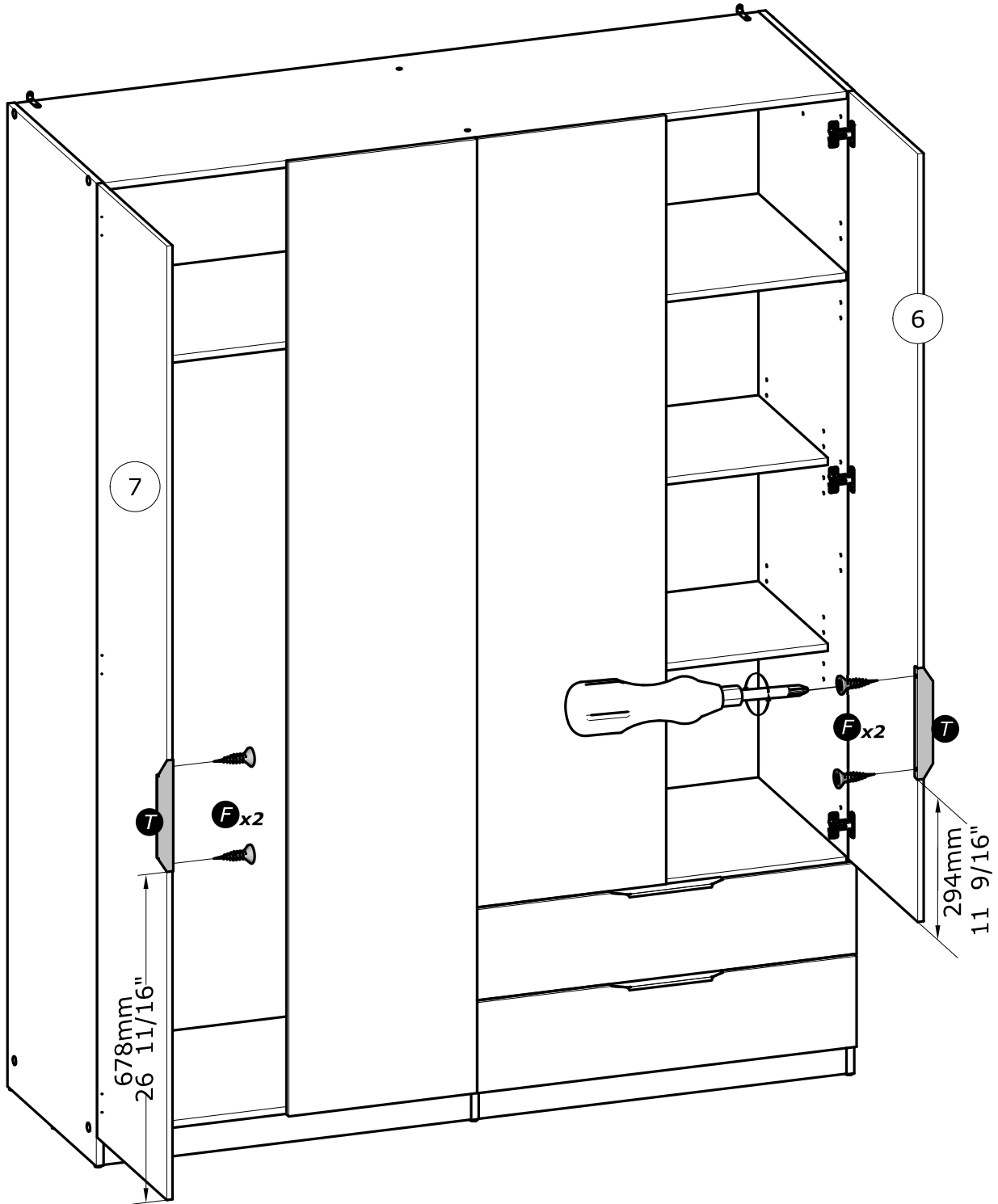
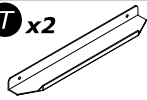

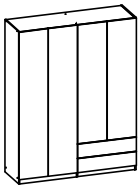

40

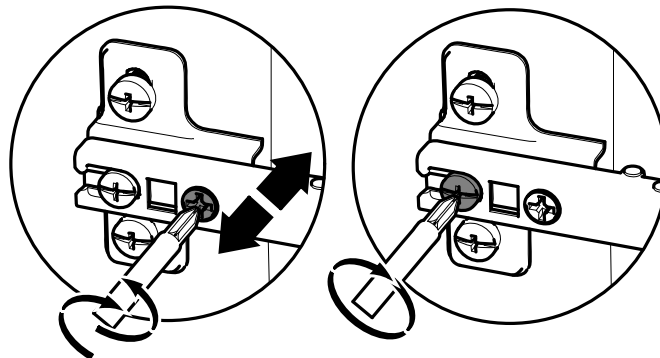
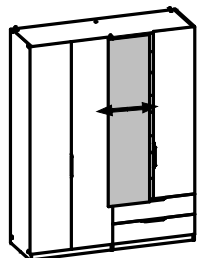
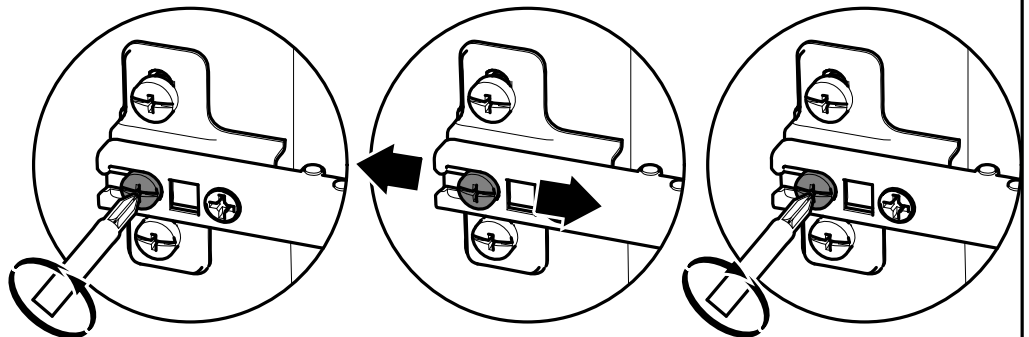
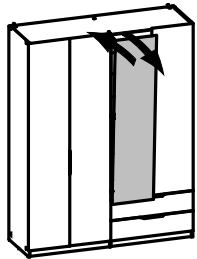
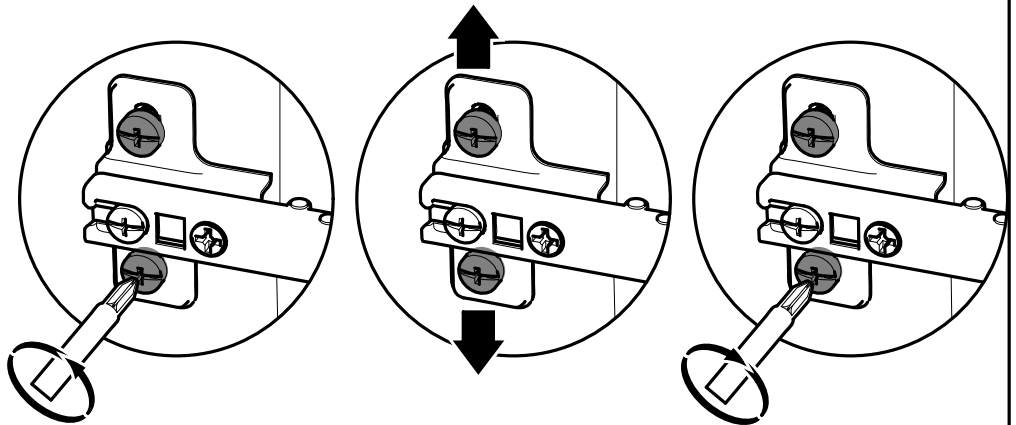
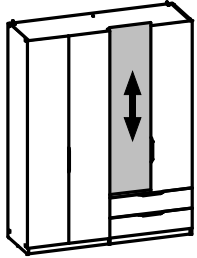

www.Demeyere.fr