

FR Façade extérieure  
 ES Fachada exterior  
 PT Fachada externa  
 IT Facciata esterna  
 EL Εξωτερική πρόσοψη  
 PL Fasada zewnętrzna  
 RO Fațadă exterioară  
 EN Exterior facade

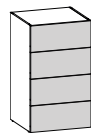

↓ 25,6	↔ 40/60/80
↗ 38	

FR Façade intérieure  
 ES Fachada interior  
 PT Fachada interna  
 IT Facciata interna  
 EL Εσωτερική πρόσοψη  
 PL Elewacja wewnętrzna  
 RO Fațadă interioară  
 EN Interior facade

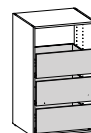

↓ 22,5	↔ 40/60/80
↗ 38	



**Made in Italy**

FR Manuel d'instructions

ES Manual de instrucciones

PT Manual de instruções

IT Manuale di istruzioni

EL Εγχειρίδιο οδηγιών

PL Instrukcja obsługi

EN Instruction manual

RO Manual de instrucțiuni

\*Garantie 15 ans / Garanzia di 15 anni / 15-year guarantee / 15 años de garantía / Εγγύηση 15 ετών /  
 Garanție de 15 ani / Garantia de 15 anos / 15-letnia gwarancja

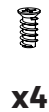
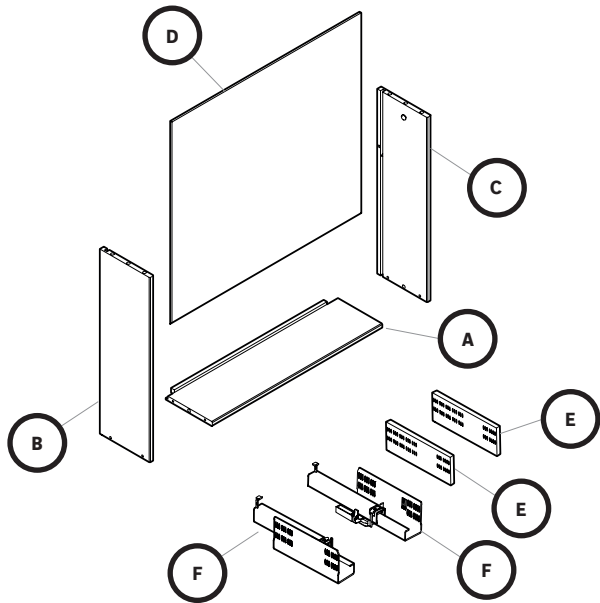
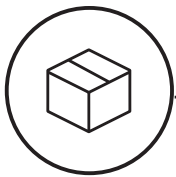

x4



x2



x4



x2



x6



x4



x2



x2

FR  
IMPORTANT, à  
conserver pour  
consultation  
ultérieure : à lire  
attentivement

ES  
IMPORTANTE,  
conservar  
para consultar  
posteriormente:  
leer atentamente

PT  
IMPORTANTE,  
conservar para  
futuras consultas:  
por favor, leia com  
atenção

IT  
IMPORTANTE,  
da conservare  
per ulteriore  
consultazione:  
da leggere  
attentamente

EL  
ΣΗΜΑΝΤΙΚΟ,  
κρατήστε το  
για μελλοντική  
αναφορά. Διαβάστε  
το προσεκτικά

PL  
WAŻNE,  
przeczytać  
uważnie i  
zachować na  
przyszłość

RO  
IMPORTANT, a  
se pastra pentru  
consultarea ulte-  
rioara: citiți cu  
atenție

EN  
IMPORTANT, to be  
retained for future  
reference: please  
read carefully

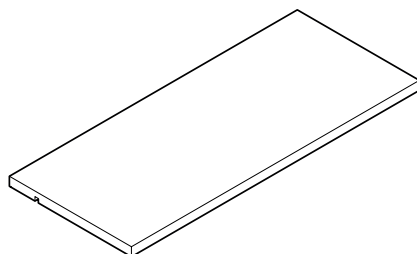
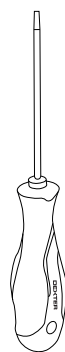
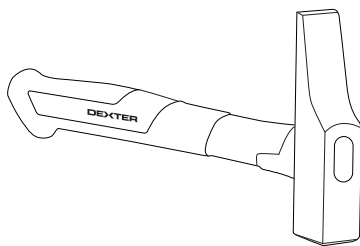

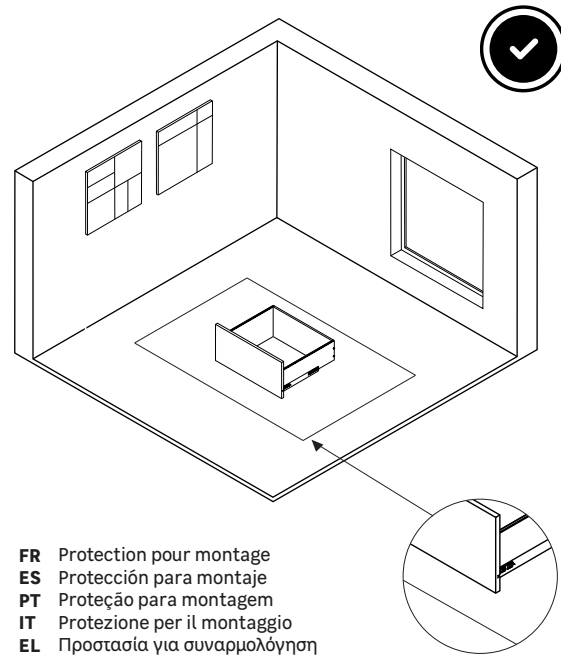
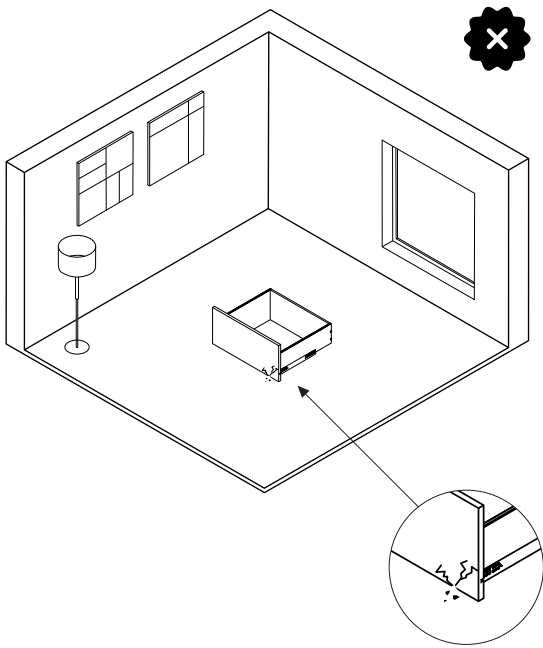

- FR Protection pour montage
- ES Protección para montaje
- PT Proteção para montagem
- IT Protezione per il montaggio
- EL Προστασία για συναρμολόγηση
- PL Bez listew przypodłogowych
- RO Protecție pentru asamblare
- EN Protection for assembly

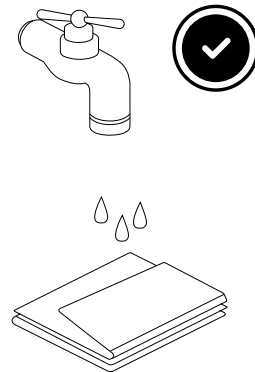
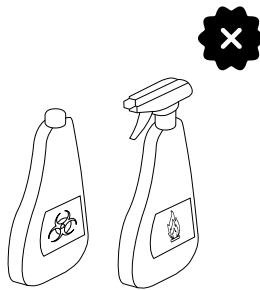
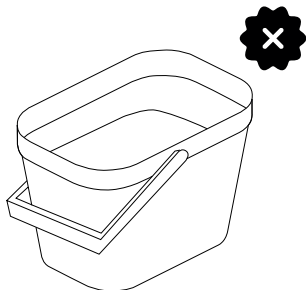

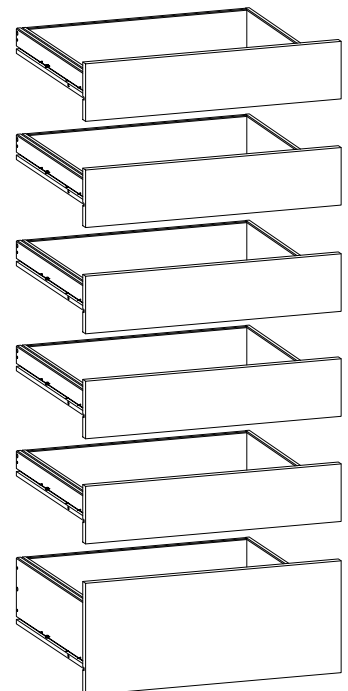
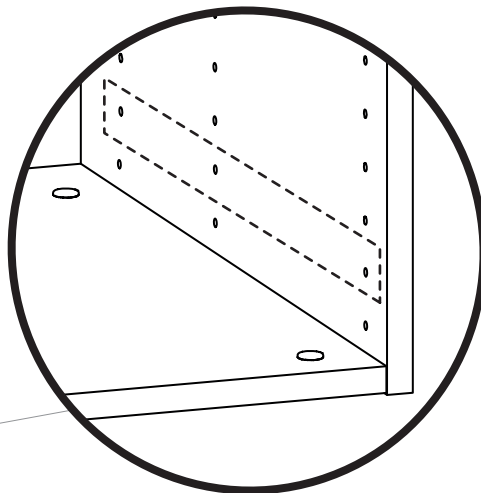
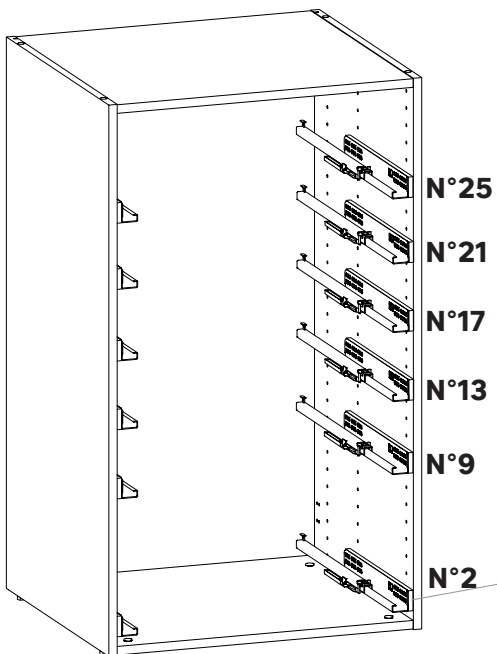
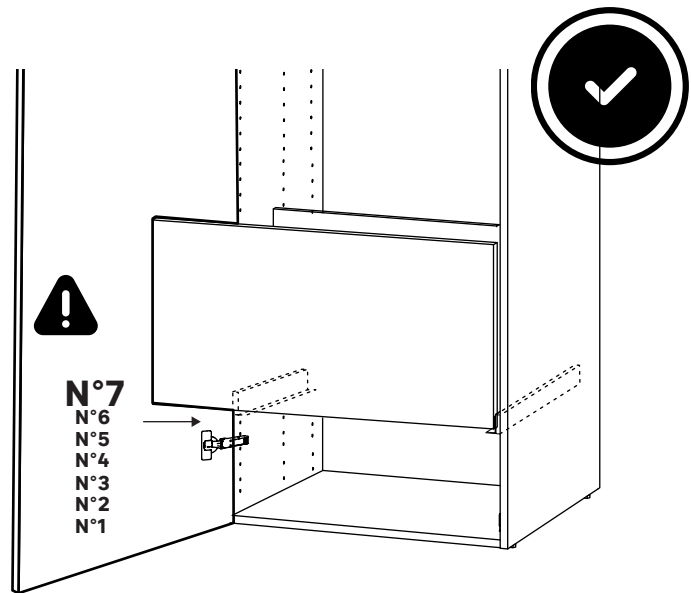
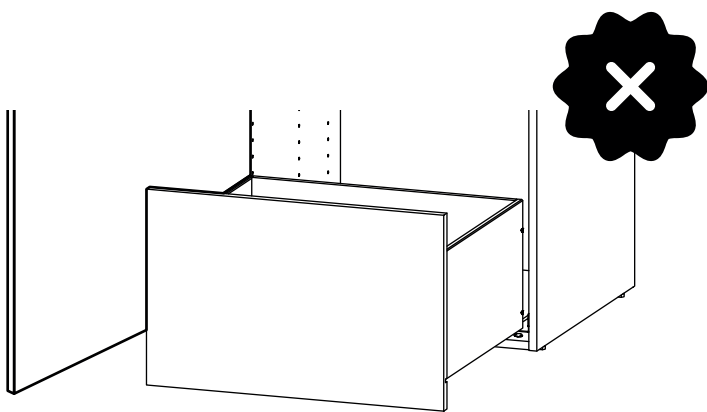
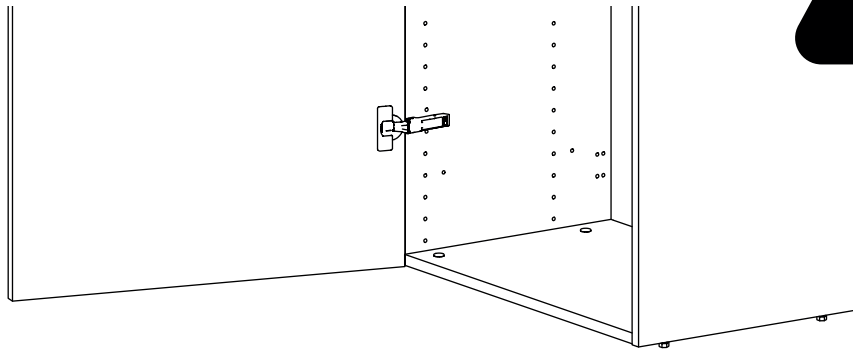

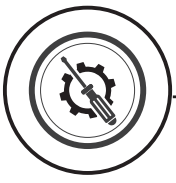

01

- FR Pensez à fixer votre caisson avant le montage du tiroir
- ES Pense en fijar su cajón antes de montar el cajón
- PT Lembre-se de fixar a caixa antes de montar a gaveta
- IT Ricordatevi di fissare il cassone prima di montare il cassetto
- EL Θυμηθείτε να στερεώσετε το κουτί πριν από τη συναρμολόγηση του συρταριού.
- PL Pamiętaj o zamocowaniu skrzynki przed montażem szuflady
- RO Nu uită să fixezi sertarul înainte de montarea sertarului
- EN Remember to fix your cabinet before assembling the drawer

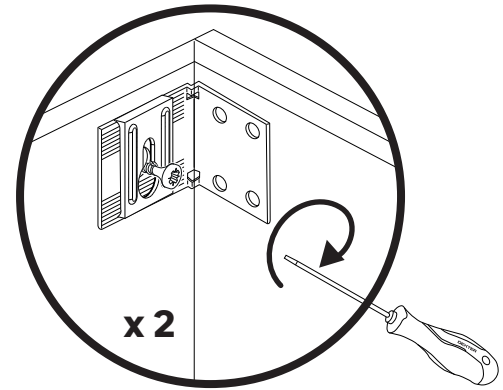
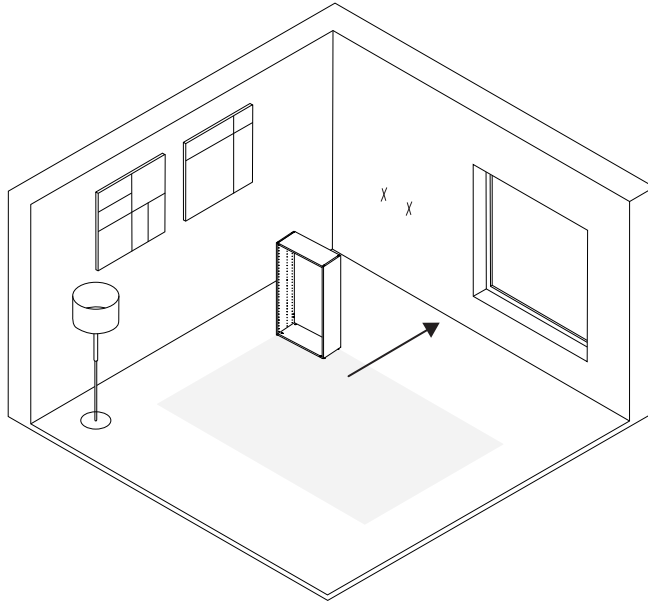

02

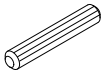

x 2

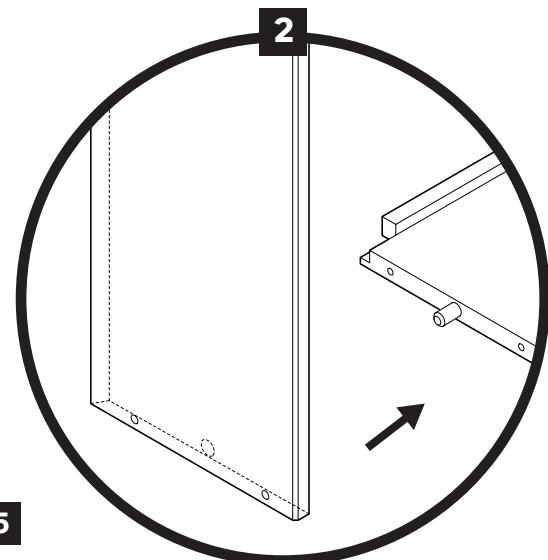
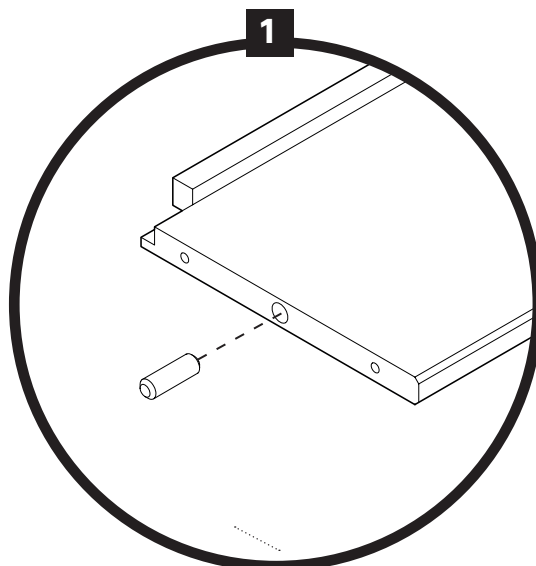
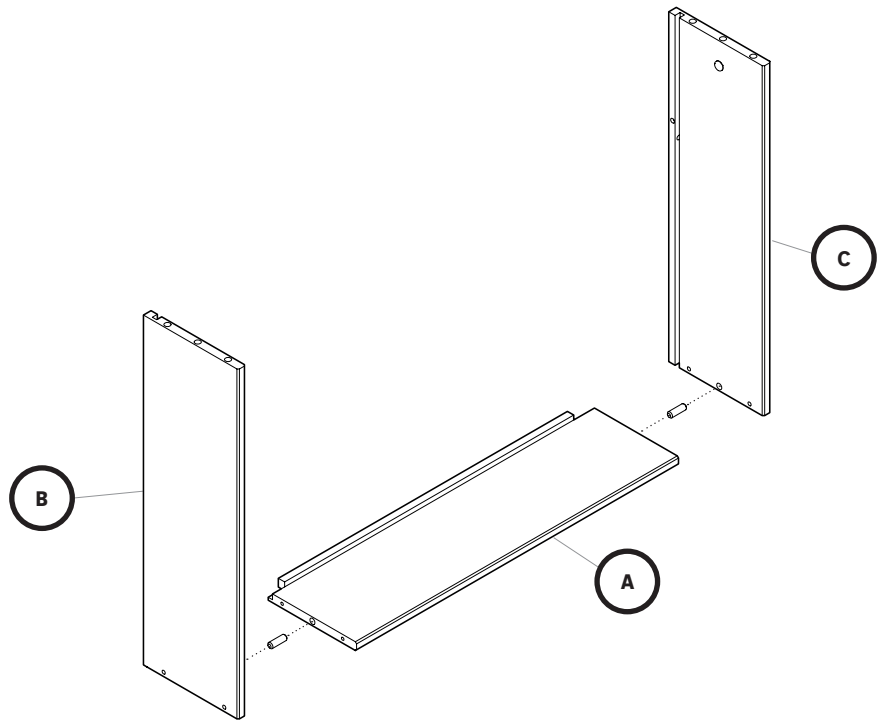
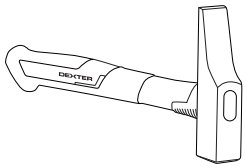

5

03

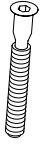

x4

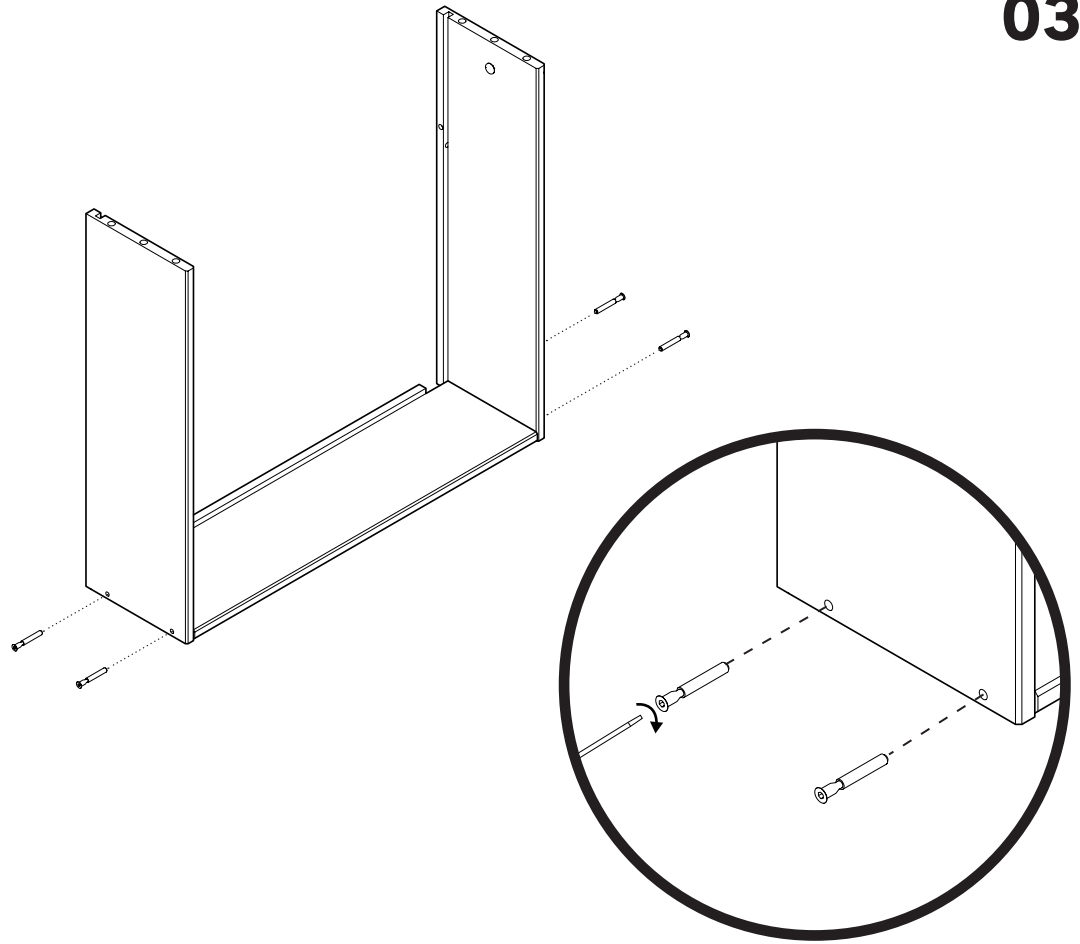
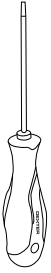

04

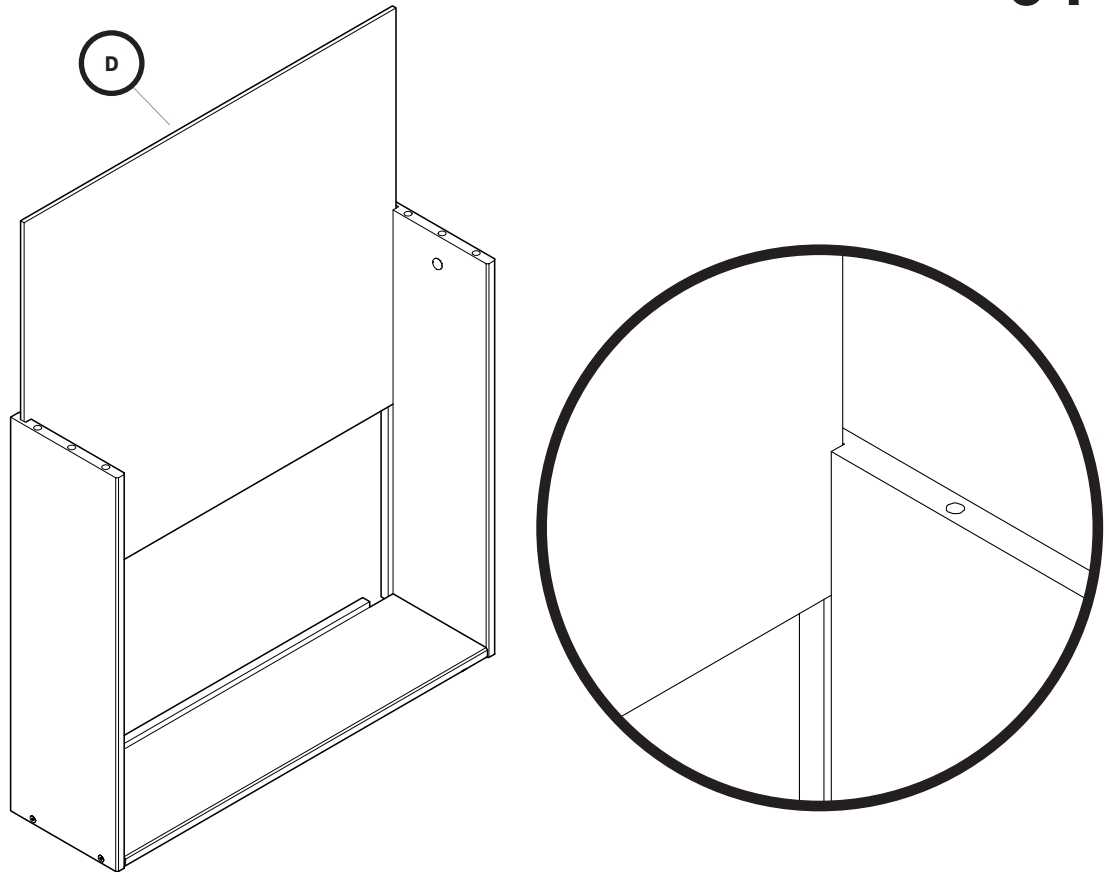

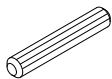

x 4

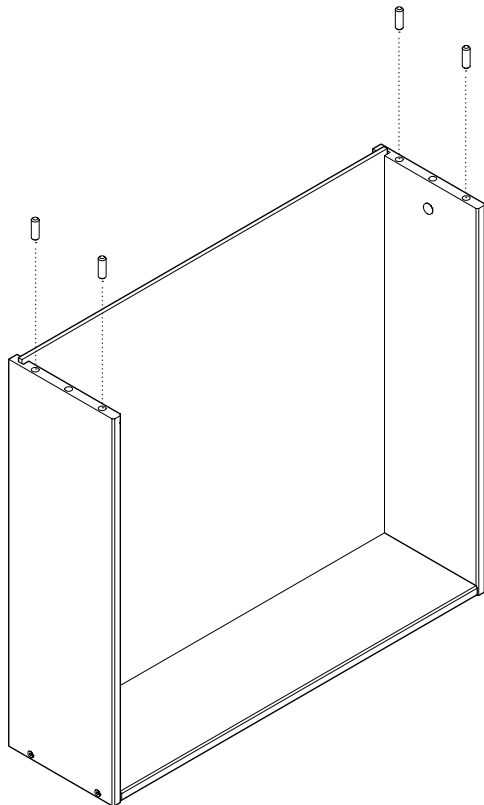
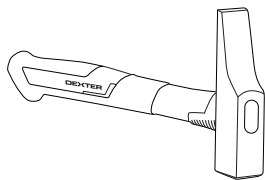

05

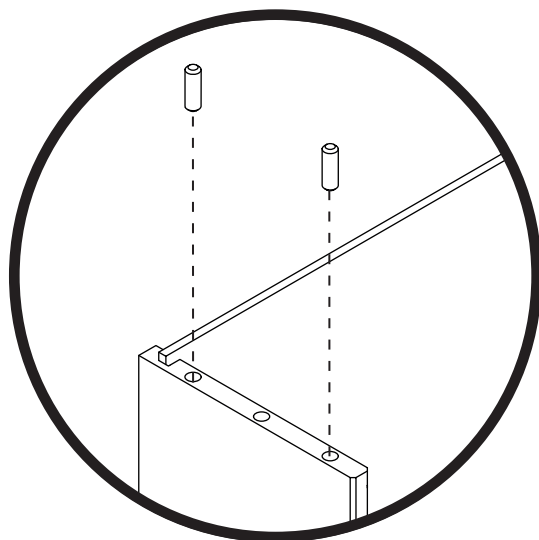

- FR Façade à acheter séparément
- ES El frente se compra por separado
- PT Frente a ser comprada separadamente
- IT Frontale da acquistare separatamente
- EL Η πρόσοψη πωλείται ξεχωριστά
- PL Front do zakupu oddzielnie
- RO Partea din față se achiziționează separat
- EN Front panels sold separately

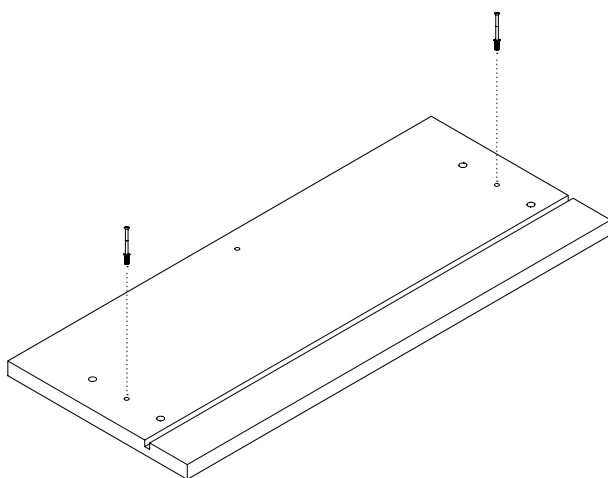
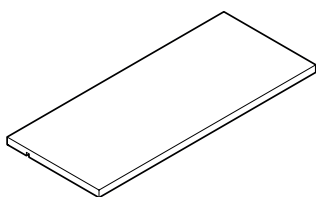

06

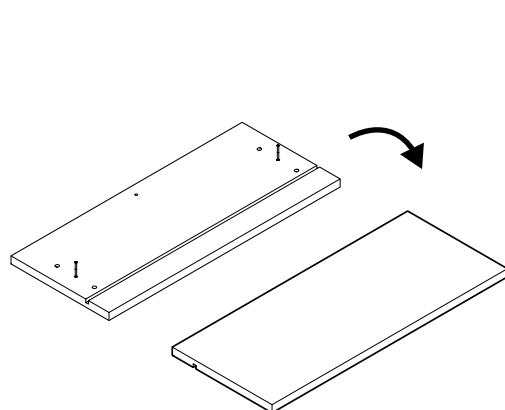
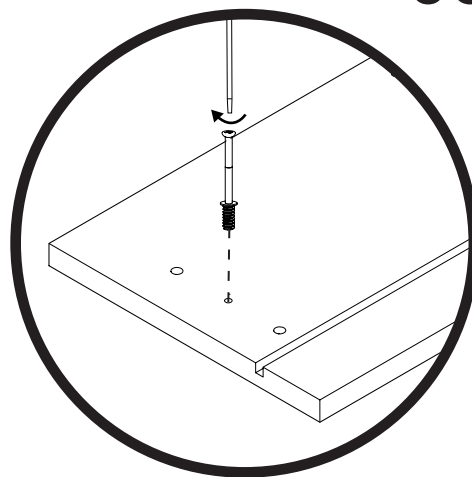

07

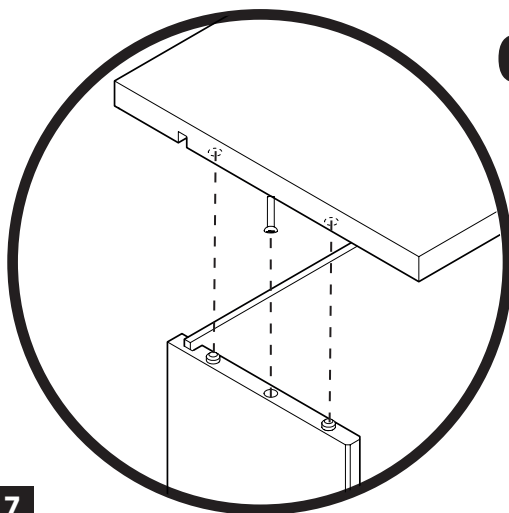

7

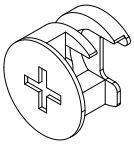

x2

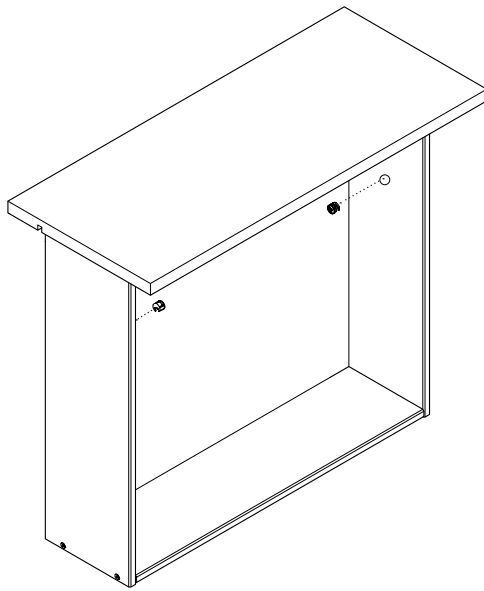

08

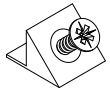
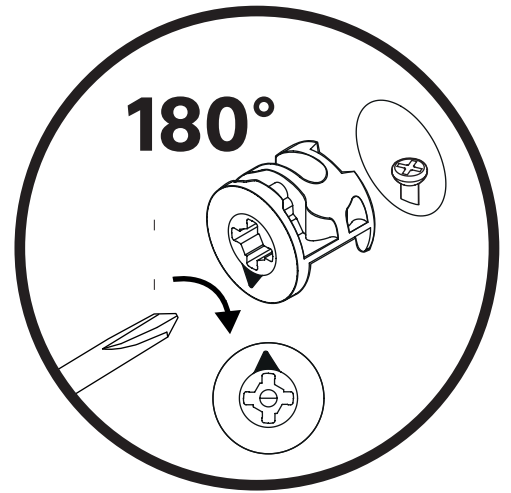

x2

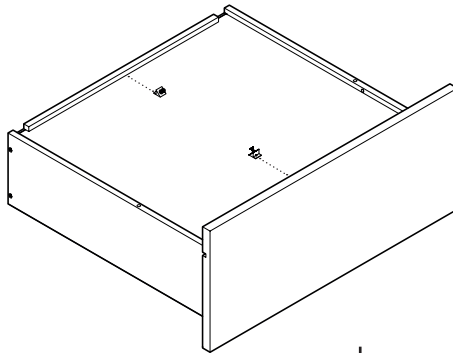

09

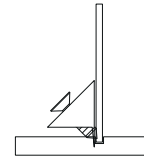
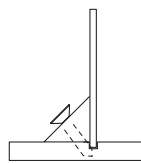
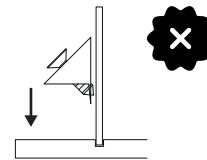
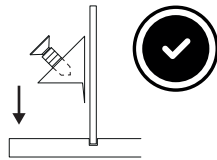
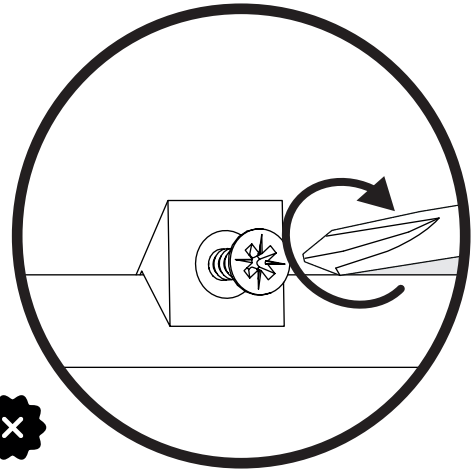

x2

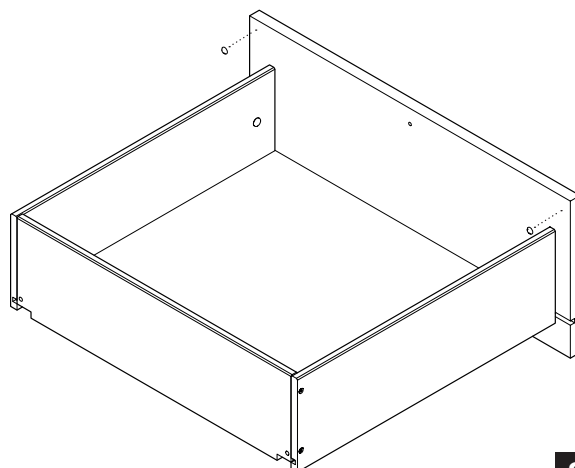

10

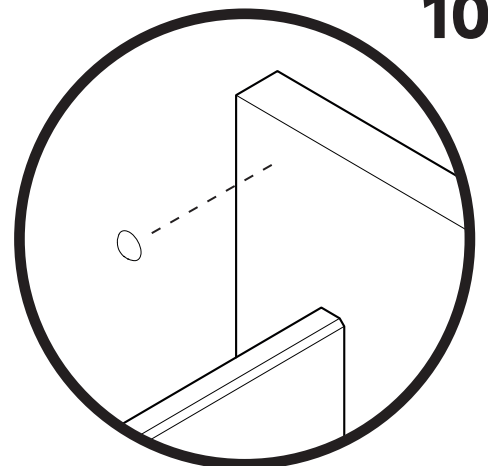

**1**

**FR** Façade intérieure  
**ES** Fachada interior  
**PT** Fachada interna  
**IT** Facciata interna  
**EL** Εσωτερική πρόσοψη  
**PL** Elewacja wewnętrzna  
**RO** Fațadă interioară  
**EN** Interior facade

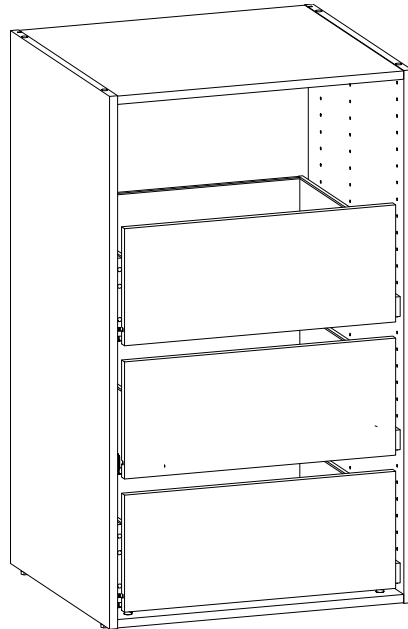
**2**

**FR** Façade extérieure  
**ES** Fachada exterior  
**PT** Fachada externa  
**IT** Facciata esterna  
**EL** Εξωτερική πρόσοψη  
**PL** Fasada zewnętrzna  
**RO** Fațadă exterioară  
**EN** Exterior facade

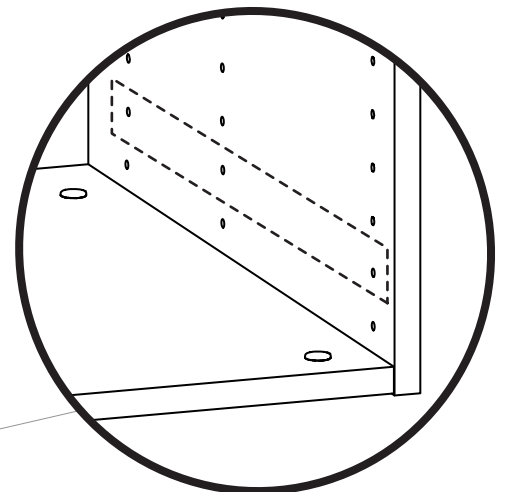
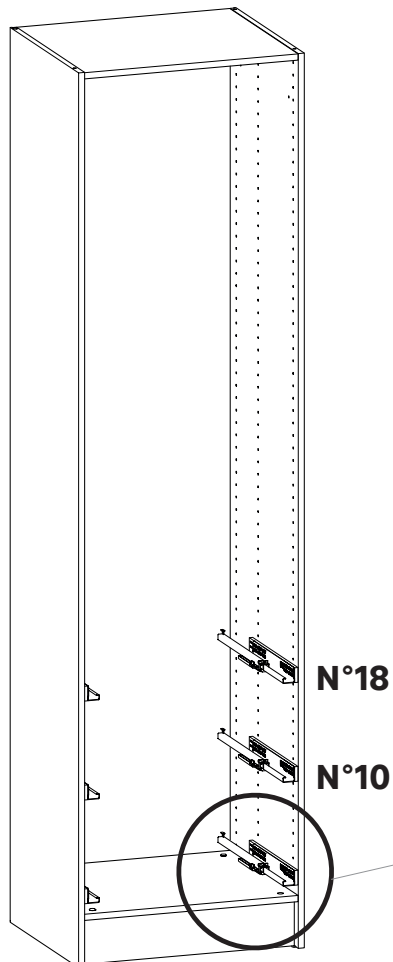
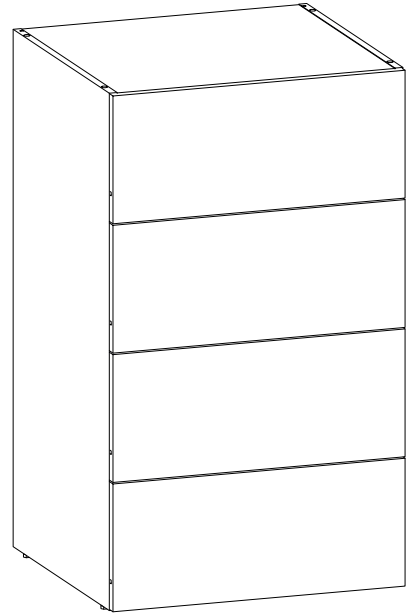

1

- FR Façade intérieure
- ES Fachada interior
- PT Fachada interna
- IT Facciata interna
- EL Εσωτερική πρόσοψη
- PL Elewacja wewnętrzna
- RO Fațadă interioară
- EN Interior facade

L

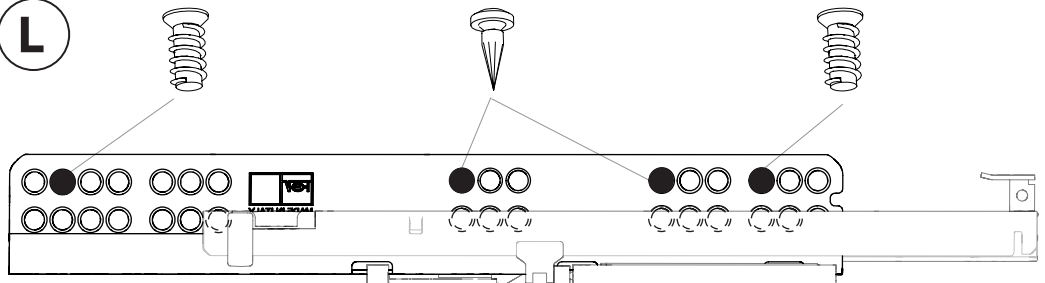

R

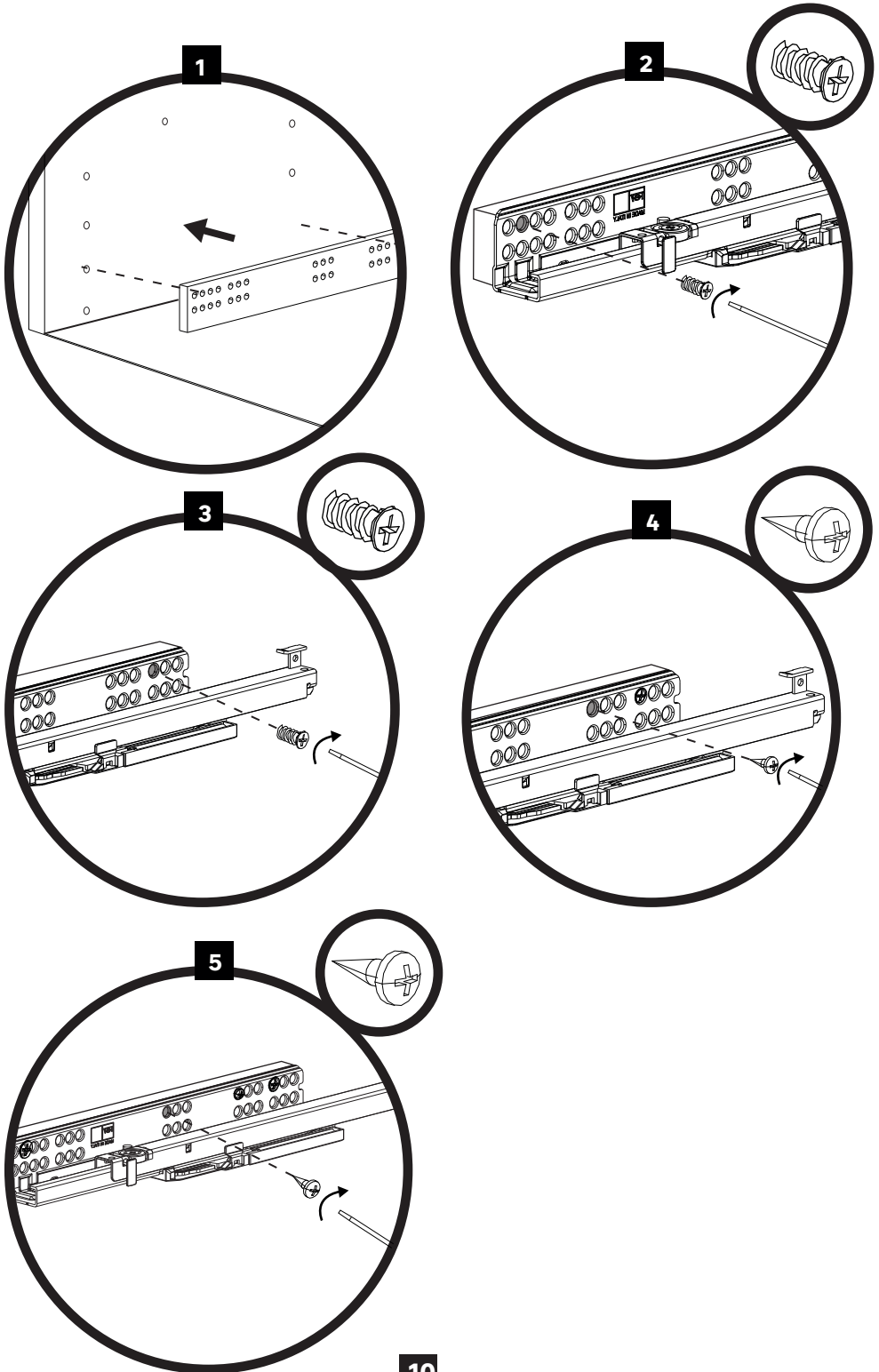
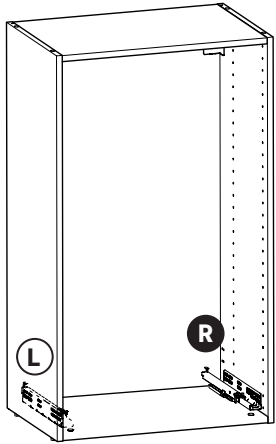
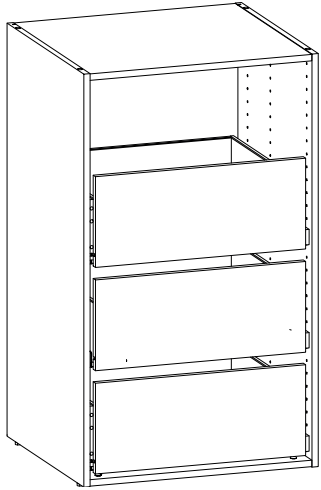
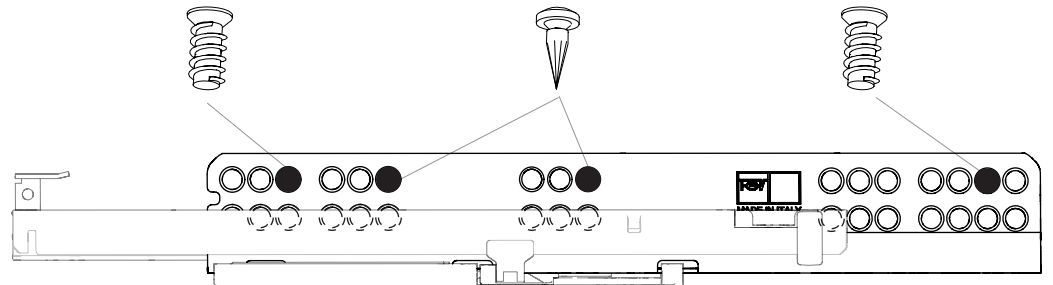

x4



x4

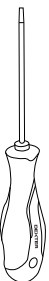

- FR Façade extérieure
- ES Fachada exterior
- PT Fachada externa
- IT Facciata esterna
- EL Εξωτερική πρόσοψη
- PL Fasada zewnętrzna
- RO Fațada exterioară
- EN Exterior facade

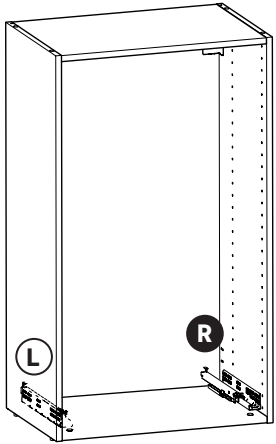
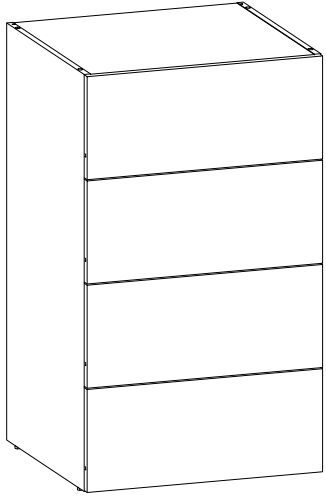

x4



x4



L

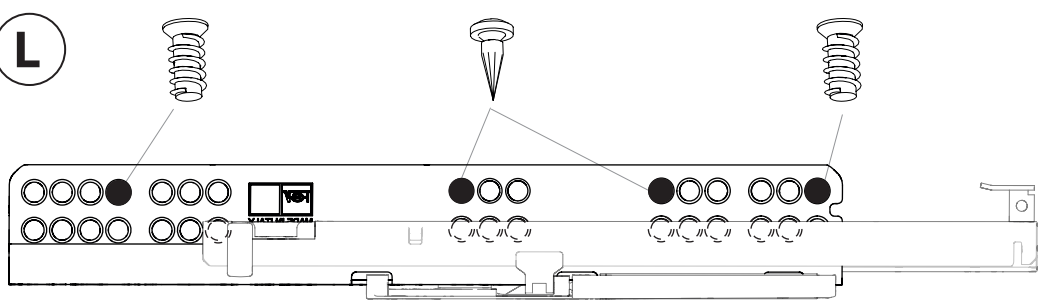

R

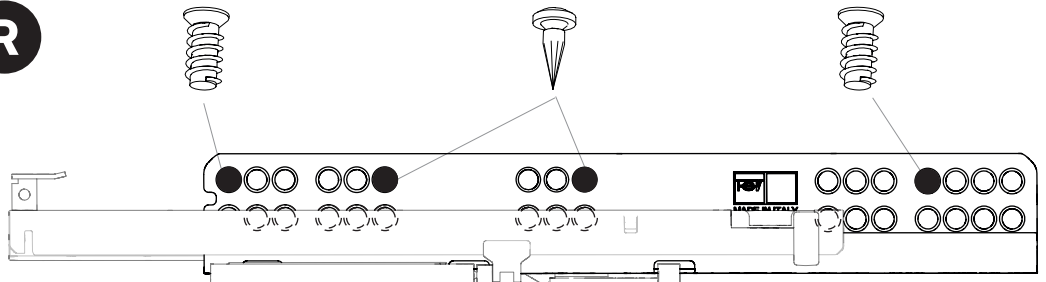

1

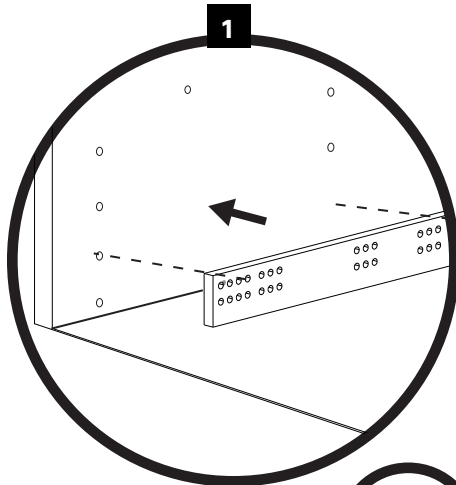

2

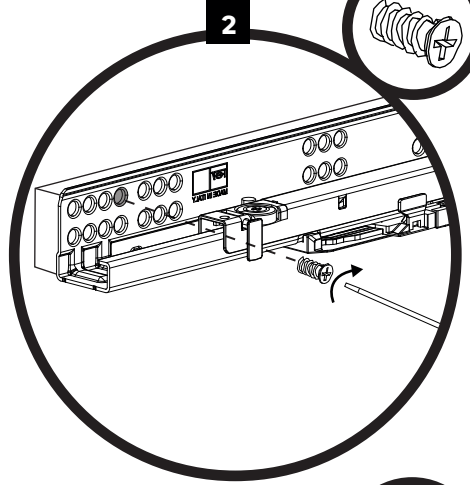

3

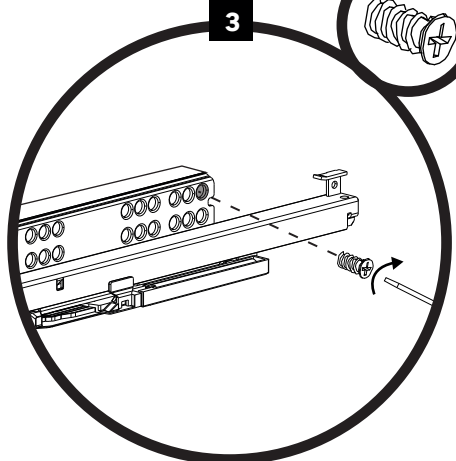

4

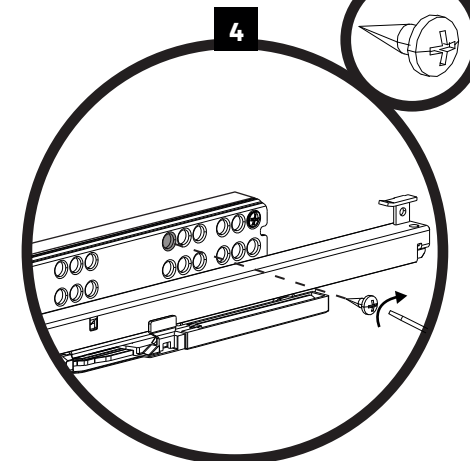

5

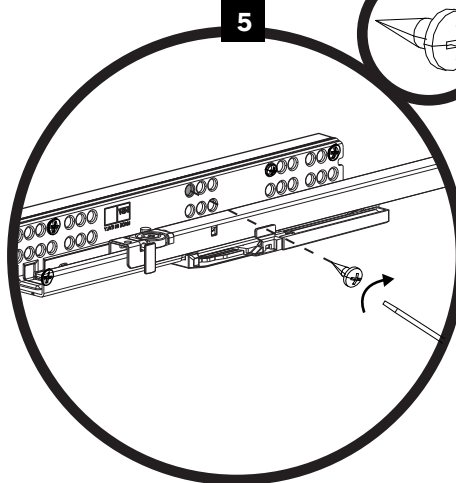

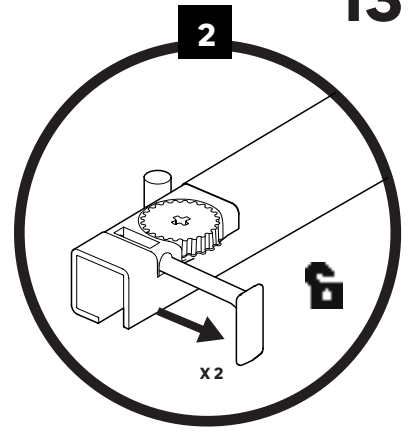
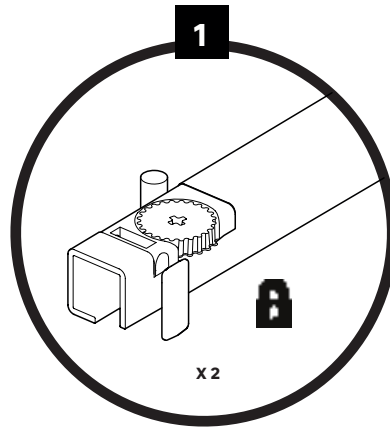
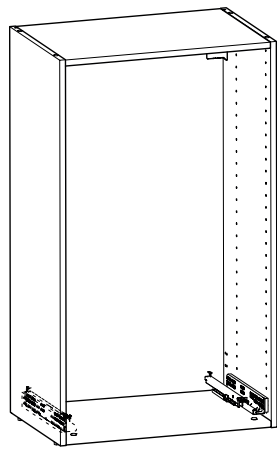

**13**

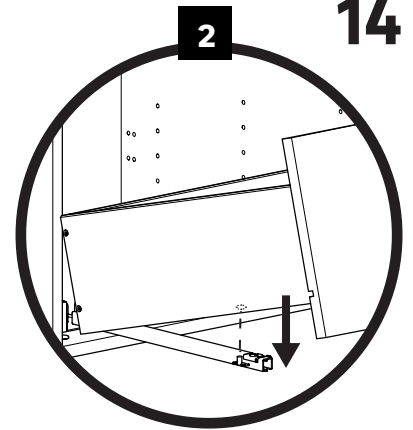
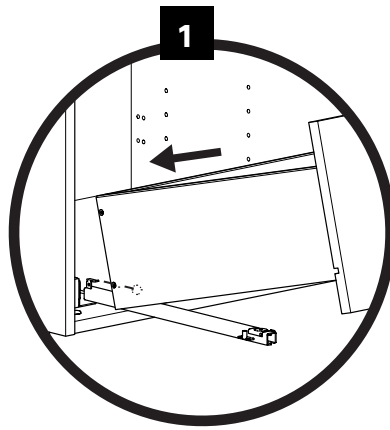
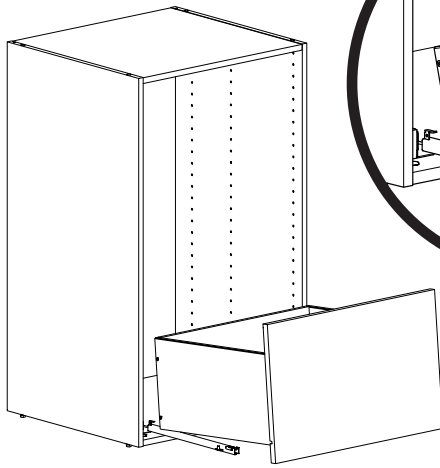

**14**

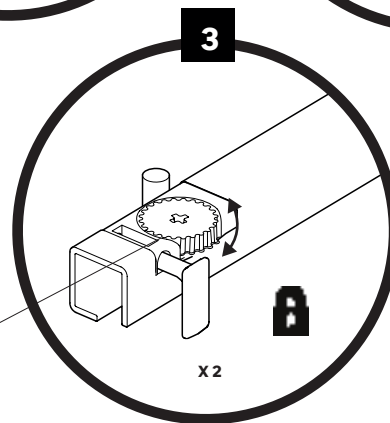
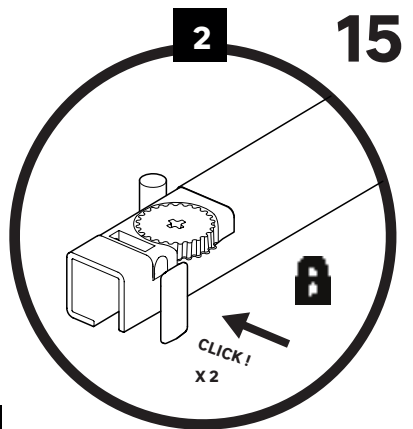
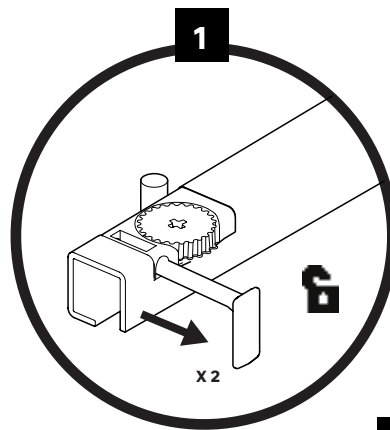
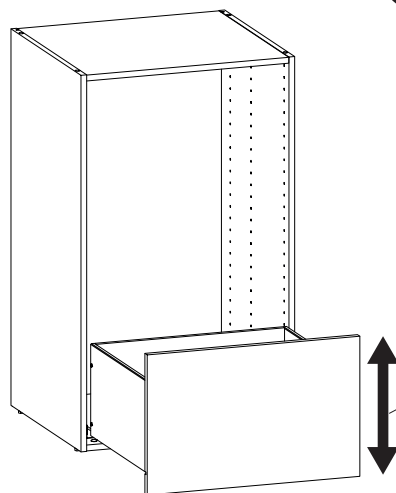

**15**

**12**









**FR** Ce meuble se recycle, s'il n'est plus utilisable, déposez-le en déchèterie. Notice à trier.  
Pour en savoir plus :  
[www.quefairedemesdechets.fr](http://www.quefairedemesdechets.fr)



**FR** **Etiquette de traçabilité présente sur le produit.**  
**Référence à communiquer en cas de demande.**

- ES** Si ya no puede utilizarse, este mueble se puede reciclar, depositelo en la unidad de clasificación de residuos.
- PT** Este móvel é reciclável. Quando deixar de ser utilizado, deposite-o num centro de reciclagem de resíduos.
- IT** Questo mobile può essere riciclato, portatelo in un'isola ecologica se inutilizzabile.
- EL** ο έπιπλο αυτό είναι ανακυκλώσιμο, εάν δεν μπορεί πλέον να χρησιμοποιηθεί τοποθετήστε το σε χώρο αποβλήτων.
- PL** Mebel ten poddawany jest recyklingowi, kiedy przestaje być użyteczny należy go dostarczyć do punktu zbiórki odpadów.
- RO** Această piesă de mobilier este reciclabilă. Dacă nu mai poate fi folosită, vă rugăm să o duceți la centrul de reciclare a deșeurilor.
- EN** This piece of furniture is recyclable. If it cannot be used anymore, please take it to the waste recycling centre.

- ES** El producto cuenta con una etiqueta de trazabilidad. En caso de reclamación, indicar esta referencia.
- PT** Etiqueta de reatrababilidade presente no produto. Referência a comunicar se solicitado.
- IT** Etichetta di tracciabilità presente sul prodotto. Codice da comunicare in caso di domanda.
- EL** τικέτα ιχνηλασιμότητας πάνω στο προϊόν. κωδικός αναφοράς πρέπει να αναφέρεται σε περίπτωση αιτήματος.
- PL** Etykieta identyfikacyjna znajduje się na produkcie. Dane referencyjne należy podać w przypadku pytań.
- RO** Etichetă de trasabilitate prezentă pe produs. Dacă se solicită, comunică această referință.
- EN** Traceability label affixed to the product. Reference to quote if requested.

**15**  
**YEAR**  
Guarantee\*

- FR** **Garantie 15 ans**
- ES** Garantía 15 años
- PT** Garantia 15 anos
- IT** Garanzia 15 anni
- EL** Εγγύηση 15 ετών
- PL** Gwarancja 15 lata
- RO** Garanție 15 ani
- EN** 15 years warranty

Imported by Adeo South Africa (PTY) LTD T/A Leroy Merlin, Hosted in Leroy Merlin Fourways Store, 35 Roos Street, Witkoppen Ext 97, Sandton, 2191 Johannesburg, Gauteng, South Africa. Tel: +27 10 493 8000 Email: [contact@leroymerlin.co.za](mailto:contact@leroymerlin.co.za)

## Adeo Services

135, rue Sadi Carnot  
CS 00001  
59790 Ronchin - France



<https://quefairedemesdechets.fr>

