



Create amazing spaces™

MANUAL

MANOR 4X6S

USER MANUAL | MODE D'EMPLOI | MANUAL DEL USUARIO | GEBRAUCHSANLEITUNG |
GEBRUIKSHANDLEIDING | MANUALE PER L'UTENTE | MANUAL DO UTILIZADOR



SKU: 17197126

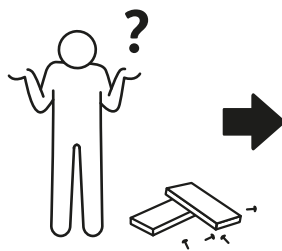

WWW.KETER.COM

US, Canada

Tel: +1877-638-7056, NACS@keter.com

Mon - Fri | 8am - 6pm ET / Lundi-Vendredi 8h - 18h

Sat - Sun | 9am - 6pm ET / Samedi-Dimanche 9h-18h

UK

Tel: +44-121-506-0008, CSUK@keter.com

Mon - Fri | 8:30am - 5pm

For other European countries see the last page

Pour les autres pays d'Europe, voir la dernière page

Para otros países europeos vea la última página

Per altri Paesi europei, consultare l'ultima pagina

Voor andere Europese landen, zie de laatste pagina



A-1265-15 5012108

WARRANTY ACTIVATION

Thank you for your purchase of the Keter shed.
In order to activate your warranty, please log onto
our website and fill in the form under warranty
activation.

keter.com/en/warrant-activation

BEFORE STARTING ASSEMBLY | AVANT DE COMMENCER LE MONTAGE | **ANTES DE EMPEZAR EL ARMADO** | VOR MONTAGEBEGINN | **VOORDAT U BEGINT TE MONTEREN** | PRIMA DI INIZIARE L'ASSEMBLAGGIO | **ANTES DE INICIAR A MONTAGEM**

Read the care and safety guidelines at the end of this manual | Check to ensure that there are no missing or damaged parts BEFORE starting or arranging assembly | Remove all parts from the package(s) and spread them out on a clean work surface | Review all assembly instructions | Assemble all the parts according to the directions in this manual. Do not skip any steps.

Lisez les instructions de précaution et de sécurité à la fin de ce manuel | Assurez-vous qu'il n'y a pas de pièces manquantes ou endommagées AVANT de commencer ou d'organiser l'assemblage | Retirez toutes les pièces du/des paquet(s) et étalez-les sur une surface de travail propre | Lisez toutes les instructions de montage | Assemblez toutes les pièces selon les instructions de ce manuel. Ne sautez aucune étape.

Lea las intrucciones de precauciones y seguridad que están al final de este manual | Asegúrese de que no faltan piezas ni están dañadas ANTES de comenzar o disponer el montaje | Saque todas las piezas del paquete o paquetes y póngalas sobre una superficie de trabajo limpia | Revise todas las instrucciones de montaje | Monte todas las piezas según las instrucciones de este manual. No se saltee ningún paso.

Lesen Sie die Sicherheitsrichtlinien am Ende des Benutzerhandbuchs durch | Prüfen Sie bitte VOR dem Zusammenbau, dass keine Teile beschädigt sind oder fehlen | Nehmen Sie alle Teile aus der Verpackung und breiten Sie sie auf einer sauberen Arbeitsfläche aus | Gehen Sie noch einmal die komplette Aufbauanleitung durch | Bauen Sie alle Teile entsprechend der Anleitung in diesem Handbuch zusammen. Lassen Sie dabei keinen Arbeitsschritt aus.

Lees de richtlijnen voor zorg en veiligheid achterin deze handleiding | Controleer dat er geen onderdelen mankeren, of beschadigd zijn, VOORDAT u met de montage begint | Haal alle onderdelen uit het pakket (of uit de pakketten) en leg ze open schoon werkoppervlak | Bekijk alle montagehandleidingen | Monteer alle onderdelen volgens de aanwijzingen van deze handleiding. Sla geen stappen over.

Leggere le linee guida di assistenza e sicurezza alla fine di questo manuale | Assicursarsi che non ci siano parti mancanti o danneggiate PRIMA di iniziare l'assemblaggio | Estrarre tutti i componenti dall'imballo e posizionarli su una superficie di lavoro pulita | Consultare tutte le istruzioni di montaggio | Assemblare tutti i componenti secondo le istruzioni contenute nel manuale. Non saltare nessuna fase.

Leia as diretrizes de cuidados e segurança que constam da parte final deste manual | Verifique para se assegurar de que não há peças em falta ou danificadas ANTES de começar a preparar a montagem | Retire todas as peças da embalagem e espalhe-as numa superfície de trabalho limpa | Reveja todas as instruções de montagem | Monte todas as peças de acordo com as instruções do manual. Não salte quaisquer passos.

REQUIRED TOOLS | OUTILS EXIGÉS | **HERRAMIENTAS NECESARIAS** | BENÖTIGTE WERKZEUGE | **BENODIGD GEREEDSCHAP** | ATTREZZATURA OCCORRENTE | **FERRAMENTAS NECESSÁRIAS**

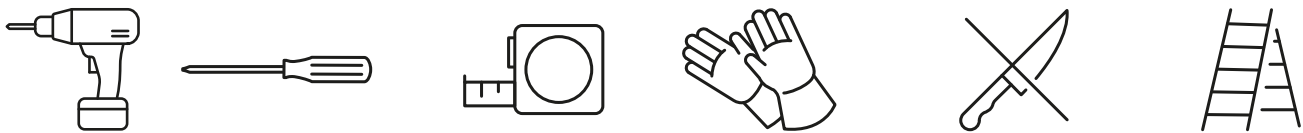

SPATULA | SPATULE | **ESPÁTULA** | SPACHTEL | **SPATEL** | SPATOLA | **ESPÁTULA**

- Use spatula (part "SPA") for easier insertion of panel into profile.
- Utilisez la spatule (partie "SPA") pour une meilleure insertion du panneau dans le profil.
- Utilice una espátula (pieza "SPA") para una mejor inserción del panel en el perfil.
- Benutzen Sie den Spachtel (Bezeichnung „SPA“), um die Platten leichter in die Nut einführen zu können.
- Gebruik spatel (onderdeel SPA) voor het gemakkelijk invoeren van het paneel in het profiel.
- Utilizzare la spatola (parte SPA) per inserire il pannello più facilmente nel profilo.
- Utilize uma espátula (peça "SPA") para facilitar a inserção do painel no perfil.

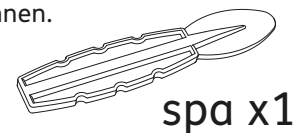

spa x1

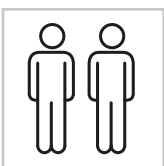

ASSEMBLY REQUIRES TWO PEOPLE | LE MONTAGE DOIT ÊTRE EFFECTUÉ PAR DEUX PERSONNES | **SE NECESITAN DOS PERSONAS PARA ARMARLO** | ZWEI PERSONEN ZUR MONTAGE NOTWENDIG | **MONTAGE VEREIST TWEE PERSONEN** | L'ASSEMBLAGGIO RICHIEDE DUE PERSONE | **A MONTAGEM EXIGE DUAS PESSOAS**



SHED PARTS | PIÈCES DE L'ABRI | PARTES DEL COBERTIZO | TEILE DES SCHUPPENS | ONDERDELEN VAN HET SCHUURTJE
| COMPONENTI DELLA CASETTA | PEÇAS DO ABRIGO

Remove all parts from the package(s) and spread them out on a clean work surface. Code letters are imprinted on each part for easy identification | Retirez toutes les pièces du/des paquet(s) et étalez-les sur une surface de travail propre. Des lettres sont imprimées sur chaque pièce pour une identification facile | Saque todas las piezas del paquete o paquetes y póngalas sobre una superficie de trabajo limpia. El código de letras está marcado en cada pieza para que sea más fácil identificarla | Nehmen Sie alle Teile aus der Verpackung und breiten Sie sie auf einer sauberen Arbeitsfläche aus. Auf jedem Teil sind Kennbuchstaben aufgedruckt, die die Zuordnung der einzelnen Teile erleichtern | Haal alle onderdelen uit het pakket (of uit de pakketten) en leg ze op een schoon werkoppervlak. Op ieder onderdeel zijn codes aangebracht voor een gemakkelijke identificatie | Rimuovere tutti i componenti dall'imbollo e posizionarli su una superficie di lavoro pulita. I codici identificativi sono impressi in ogni componente per una semplice identificazione | Retire todas as peças da embalagem e espalhe-as numa superfície de trabalho limpa. Existem letras de código impressas em cada peça para fácil identificação

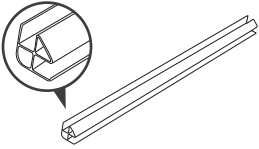
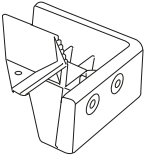
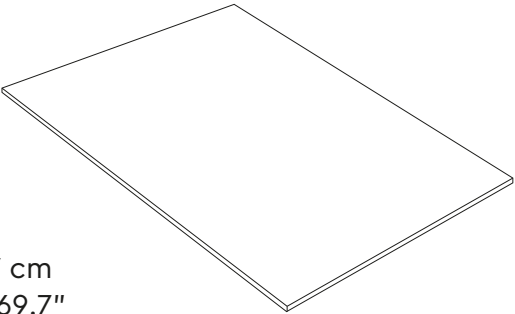
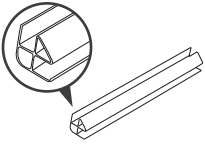

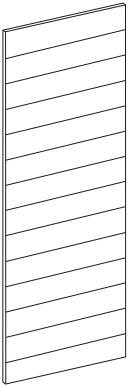
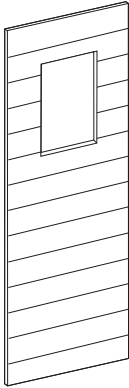
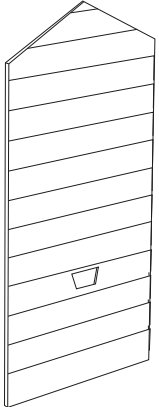
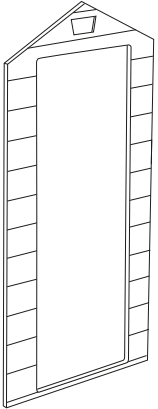
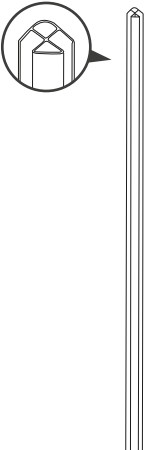
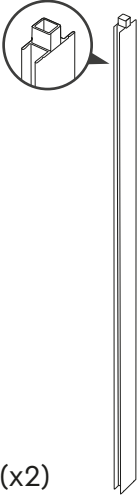
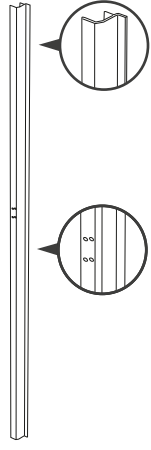

FLOOR PARTS | ÉLÉMENTS DU PLANCHER | PARTES DEL SUELO | BODENTEILE | VLOERPANELEN | COMPONENTI DEL PAVIMENTO | PEÇAS DO CHÃO

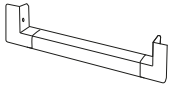
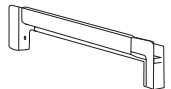
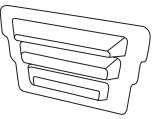
<p>fc1(x2) 172 cm 67.7"</p> 	 t (x4)	 f1a (x1) 111x177 cm 43.7"x69.7"
<p>c1z(x2) 106 cm 41.7"</p> 		

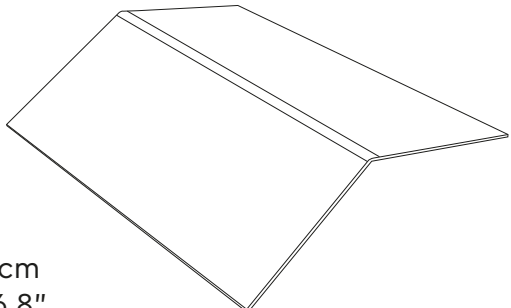
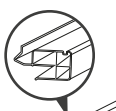

WALL PARTS | PIÈCES DES MURS | PARTES DE LAS PAREDES | WANDELEMENTE | MUURONDERDELEN | COMPONENTI DELLA PARETE | PAINÉIS LATERAIS

<p>w1d (x3) 88x172 cm 34.6"x67.7"</p> 	<p>s1d (x1) 88x172 cm 34.6"x67.7"</p> 	<p>bu1b (x1) 111x190 cm 43.7"x74.8"</p> 	<p>fu1c (x1) 111x190 cm 43.7"x74.8"</p> 		
<p>cc (x4) 168 cm 66.1"</p> 	<p>h1c (x2) 165 cm 65"</p> 	<p>lew1f (x1) 162 cm 63.8"</p> 	<p>rew1f (x1) 162 cm 63.8"</p> 	<p>lwf (x1)</p>  <p>uwf (x1)</p> 	<p>v (x2)</p> 

ROOF PARTS | PIÈCES DU TOIT | DACHELEMENTE | PARTES DEL TECHO | DAKONDERDELEN | COMPONENTI DEL TETTO | PEÇAS DO TELHADO

 <p>e1d (x4) 56 cm 22"</p>	 <p>rc (x4)</p>	 <p>r1m (x1) 121x195 cm 43.6"x76.8"</p>
 <p>rc1 (x2) 172 cm 67.7"</p>	 <p>kc (x2)</p>	

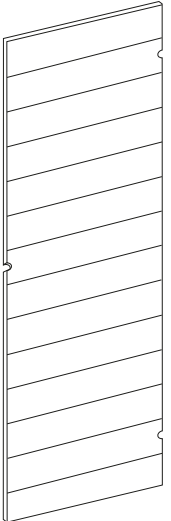
DOOR PARTS | PIÈCES DE LA PORTE | PARTES DE LA PUERTA | TÜRELEMENTE | DEURONDERDELEN | COMPONENTI DELLA PORTA | PEÇAS DAS PORTAS

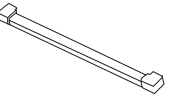
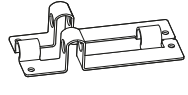
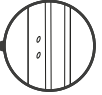
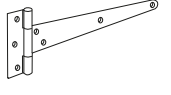
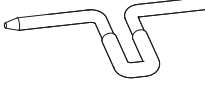
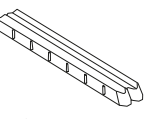
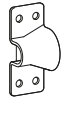
 <p>msd (x1) 62x157 cm 24.4"x61.9"</p>	 <p>ldf (x1) 157 cm 61.9"</p>	 <p>rdf (x1) 157 cm 61.9"</p>	 <p>uldf (x2)</p>	 <p>smdl (x1)</p>	
	 <p>dh (x2)</p>	 <p>dh (x2)</p>	 <p>smdp (x1)</p>	 <p>dc (x3)</p>	 <p>smdb (x1)</p>

WINDOW PARTS | PIÈCES DE LA FENÊTRE | PARTES DE LA VENTANA | FENSTERELEMENTE | VENSTERONDERDELEN | COMPONENTI DELLA FINESTRA | PEÇAS DA JANELA

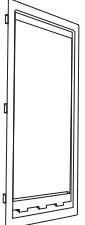
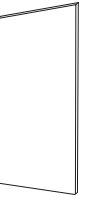
 <p>wi-in (x1)</p>	 <p>wi-out (x1)</p>	 <p>mdg (x1)</p>
---	--	---

Packaging may contain some additional small parts for use as spare parts | L'emballage peut contenir de petites pièces supplémentaires à utiliser comme pièces de rechange | El envoltorio puede contener algunas piezas pequeñas adicionales que se pueden utilizar como repuestos | In der Verpackung können kleine Zusatzteile enthalten sein, die als Ersatzteile genutzt werden können | De verpakking kan een aantal kleine extra onderdelen bevatten, die als reserveonderdeel gebruikt kunnen worden | L'imballo potrebbe contenere piccoli componenti supplementari da utilizzare come ricambistica | A embalagem pode conter algumas pequenas peças adicionais para utilização como peças de reposição

NOTE: Due to variations in production, the actual assembled size may vary slightly from the specified dimensions.

REMARQUE: En raison de variantes dans la production, la taille de montage réelle peut différer quelque peu des dimensions indiquées.

NOTA: debido a las variaciones en la producción, el tamaño real al montarlo puede variar ligeramente con respecto a las dimensiones especificadas.

BITTE BEACHTEN: Aufgrund von Abweichungen in der Herstellung kann die tatsächliche Größe leicht von den angegebenen Maßen abweichen.

LET OP: vanwege afwijkingen in de productie kan de werkelijke afmeting na montage een klein beetje afwijken van de opgegeven afmetingen.

NOTA: A causa di variazioni nella produzione, le dimensioni effettive del prodotto assemblato potrebbero variare leggermente da quelle indicate.

NOTA: Devido a variações na produção o tamanho real da montagem poderá variar ligeiramente das dimensões especificadas.

SCREWS | VIS | SCHRAUBEN | TORNILLOS | SCHROEVEN | VITI | PARAFUSOS | ŠRUBY

- Please refer to the screw index below to find the actual screw size.
- Veuillez vous référer à l'index des vis ci-dessous pour trouver la taille de la vis réelle.
- Remítase al índice los tornillos presentado a continuación para informarse sobre el tamaño real de los mismos.
- Bitte benutzen Sie die u.a. Tabelle um die richtige Schraubengröße zu bestimmen.
- Raadpleeg de schroevenindex hieronder om de feitelijke schroevengrootte te vinden.
- Consultare il riepilogo delle viti riporto qui di seguito al fine di individuare le effettive dimensioni delle viti.
- Por favor, consulte o índice de parafusos abaixo para identificar o tamanho certo do parafuso.

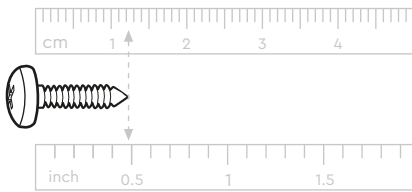

S13b(x30) 0.47"/12 mm

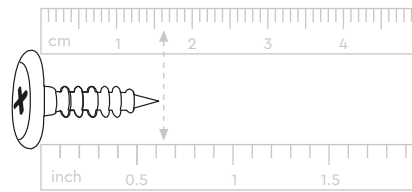

Sc15(x8) 0.63"/16 mm

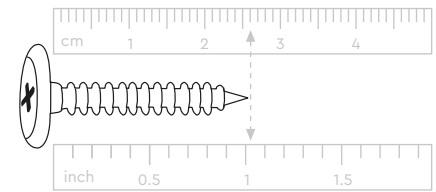

S26b(x125) 1"/26 mm

SELF-DRILLING SCREW | VIS AUTO-FOREUSE | TORNILLO DE AUTO-ATORNILLADO | SELBSTBOHRENDE SCHRAUBE | ZELF TAPPENDE SCHROEF | VITI AUTOFIETTANTI | PARAFUSO AUTORROSCANTE

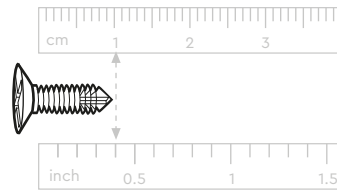
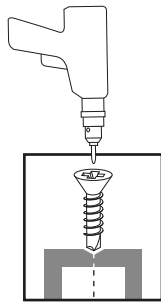
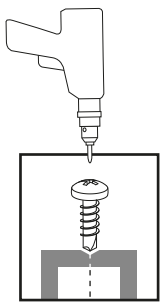

dS2b(x4) 0.39"/10 mm

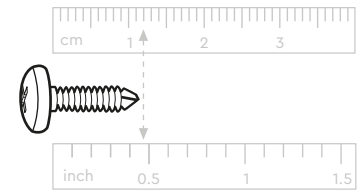

S10b(x16) 0.47"/12 mm

- Use a powerful electric screwdriver. The screw should drill itself to a metal profile.
- Utilisez un tournevis électrique puissant. La vis doit percer elle-même une tablette de métal.
- Use un destornillador eléctrico potente. El propio tornillo debería perforar el contorno de metal.
- Verwenden Sie bitte einen leistungsstarken, elektrischen Schraubenzieher. Die Schraube soll sich in das Metallprofil hineinschrauben, ohne vorzubohren.
- Gebruik een krachtige elektrische schroevendraaier. De schroef moet zichzelf in een metalen profiel boren.
- Utilizzare un avvitatore elettrico dotato di buona potenza. La vite si fisserà di conseguenza al profilo metallico.
- Utilize uma chave de fendas elétrica potente. O parafuso deve atarrachar-se num contorno de metal.