



Create amazing spaces™

MANUAL

PENT 11x7

USER MANUAL | MODE D'EMPLOI | MANUAL DEL USUARIO | MONTAGEANLEITUNG |
MONTAGEHANDLEIDING | MANUALE PER L'UTENTE | MANUAL DO UTILIZADOR

SIGNATURE
Collection™

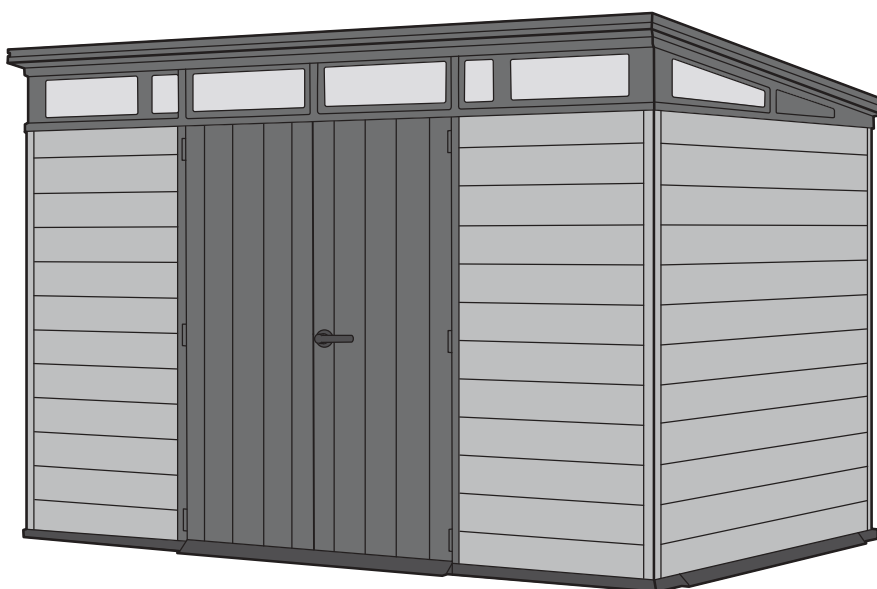

IMPORTANT | IMPORTANT | IMPORTANTE | IMPORTANTE

RETAIN FOR FUTURE REFERENCE: READ CAREFULLY

À CONSERVER POUR DE FUTURS BESOINS DE RÉFÉRENCE : À LIRE SOIGNEUSEMENT

CONSERVE PARA FUTURA REFERENCIA. LEA CUIDADOSAMENTE

CONSERVARE PER RIFERIMENTO FUTURO: LEGGERE ATTENTAMENTE

For outdoor use only. Not for commercial use | **Utilisation non commerciale à l'extérieur seulement** |
Para uso externo. No para uso comercial.

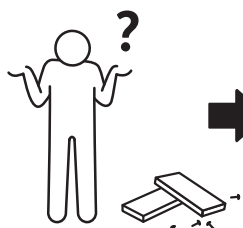

WWW.KETER.COM

US, Canada: (EN/FR)

keter.com/en-us/contact-us.html

Tel: +1-888-374-4262

Email: NACS@keter.com

UK

Tel: +44-121-506-0008, CSUK@keter.com

Mon - Fri | 8am - 4pm

For other European countries see the last page

Pour les autres pays d'Europe, voir la dernière page

Para otros países europeos vea la última página

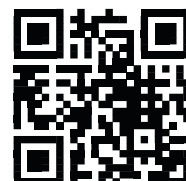

BEFORE STARTING ASSEMBLY | AVANT DE COMMENCER LE MONTAGE | ANTES DE EMPEZAR EL ARMADO | VOR MONTAGEBEGINN | VOORDAT U BEGINT TE MONTEREN | PRIMA DI INIZIARE L'ASSEMBLAGGIO | ANTES DE INICIAR A MONTAGEM

Read the care and safety guidelines at the end of this manual | Check to ensure that there are no missing or damaged parts BEFORE starting or arranging assembly | Remove all parts from the package(s) and spread them out on a clean work surface | Review all assembly instructions | Assemble all the parts according to the directions in this manual. Do not skip any steps.

Lisez les instructions de précaution et de sécurité à la fin de ce manuel | Assurez-vous qu'il n'y a pas de pièces manquantes ou endommagées AVANT de commencer ou d'organiser l'assemblage | Retirez toutes les pièces du/des paquet(s) et étalez-les sur une surface de travail propre | Lisez toutes les instructions de montage | Assemblez toutes les pièces selon les instructions de ce manuel. Ne sautez aucune étape.

Lea las intrucciones de precauciones y seguridad que están al final de este manual | Asegúrese de que no faltan piezas ni están dañadas ANTES de comenzar o disponer el montaje | Saque todas las piezas del paquete o paquetes y póngalas sobre una superficie de trabajo limpia | Revise todas las instrucciones de montaje | Monte todas las piezas según las instrucciones de este manual. No se saltee ningún paso.

Lesen Sie die Sicherheitsrichtlinien am Ende des Benutzerhandbuchs durch | Prüfen Sie bitte VOR dem Zusammenbau, dass keine Teile beschädigt sind oder fehlen | Nehmen Sie alle Teile aus der Verpackung und breiten Sie sie auf einer sauberen Arbeitsfläche aus | Gehen Sie noch einmal die komplette Aufbauanleitung durch | Bauen Sie alle Teile entsprechend der Anleitung in diesem Handbuch zusammen. Lassen Sie dabei keinen Arbeitsschritt aus.

Lees de richtlijnen voor zorg en veiligheid achterin deze handleiding | Controleer dat er geen onderdelen mankeren, of beschadigd zijn, VOORDAT u met de montage begint | Haal alle onderdelen uit het pakket (of uit de pakketten) en leg ze opeen schoon werkoppervlak | Bekijk alle montagehandleidingen | Monteer alle onderdelen volgens de aanwijzingen van deze handleiding. Sla geen stappen over.

Leggere le linee guida di assistenza e sicurezza alla fine di questo manuale | Assicurarsi che non ci siano parti mancanti o danneggiate PRIMA di iniziare l'assemblaggio | Estrarre tutti i componenti dall'imballo e posizzarli su una superficie di lavoro pulita | Consultare tutte le istruzioni di montaggio | Assemblare tutti i componenti secondo le istruzioni contenute nel manuale. Non saltare nessuna fase.

Leia as diretrizes de cuidados e segurança que constam da parte final deste manual | Verifique para se assegurar de que não há peças em falta ou danificadas ANTES de começar a preparar a montagem | Retire todas as peças da embalagem e espalhe-as numa superfície de trabalho limpa | Reveja todas as instruções de montagem | Monte todas as peças de acordo com as instruções do manual. Não salte quaisquer passos.

REQUIRED TOOLS | OUTILS EXIGÉS | HERRAMIENTAS NECESARIAS | BENÖTIGTE WERKZEUGE | BENODIGD GEREEDSCHAP | ATTREZZATURA OCCORRENTE | FERRAMENTAS NECESSÁRIAS

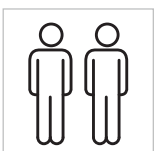
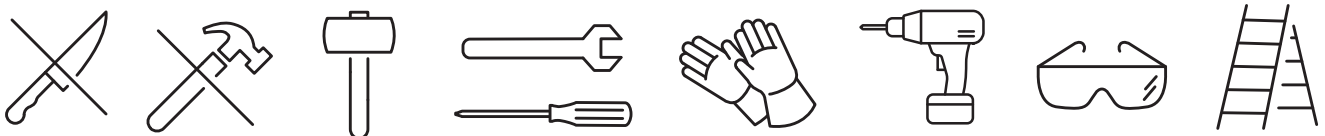

ASSEMBLY REQUIRES TWO PEOPLE | LE MONTAGE DOIT ÊTRE EFFECTUÉ PAR DEUX PERSONNES | SE NECESITAN DOS PERSONAS PARA ARMARLO | ZWEI PERSONEN ZUR MONTAGE NOTWENDIG | MONTAGE VEREIST TWEE PERSONEN | L'ASSEMBLAGGIO RICHIEDE DUE PERSONE | A MONTAGEM EXIGE DUAS PESSOAS

SHED PARTS | PIÈCES DE L'ABRI | PARTES DEL COBERTIZO | TEILE DES SCHUPPENS | ONDERDELEN VAN HET SCHUURTJE
| COMPONENTI DELLA CASETTA | PEÇAS DO ABRIGO

Remove all parts from the package(s) and spread them out on a clean work surface | Code letters are imprinted on each part for easy identification | Retirez toutes les pièces du/des paquet(s) et étalez-les sur une surface de travail propre | Des lettres sont imprimées sur chaque pièce pour une identification facile | Saque todas las piezas del paquete o paquetes y póngalas sobre una superficie de trabajo limpia | El código de letras está marcado en cada pieza para que sea más fácil identificarla | Nehmen Sie alle Teile aus der Verpackung und breiten Sie sie auf einer sauberen Arbeitsfläche aus | Auf jedem Teil sind Kennbuchstaben aufgedruckt, die die Zuordnung der einzelnen Teile erleichtern | Haal alle onderdelen uit het pakket (of uit de pakketten) en leg ze op een schoon werkoppervlak | Op ieder onderdeel zijn codes aangebracht voor een gemakkelijke identificatie | Rimuovere tutti i componenti dall'imballo e posizzarli su una superficie di lavoro pulita | I codici identificativi sono impressi in ogni componente per una semplice identificazione | Retire todas as peças da embalagem e espalhe-as numa superfície de trabalho limpa | Existem letras de código impressas em cada peça para fácil identificação

FLOOR PARTS | ÉLÉMENTS DU PLANCHER | PARTES DEL SUELO | BODENTEILE | VLOERPANELEN | COMPONENTI DEL PAVIMENTO | PEÇAS DO CHÃO

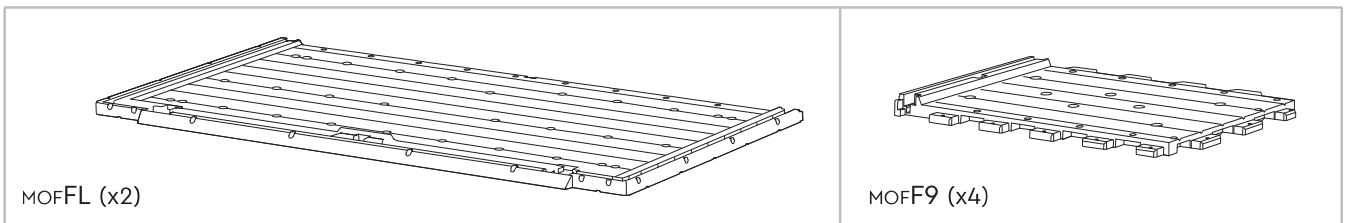

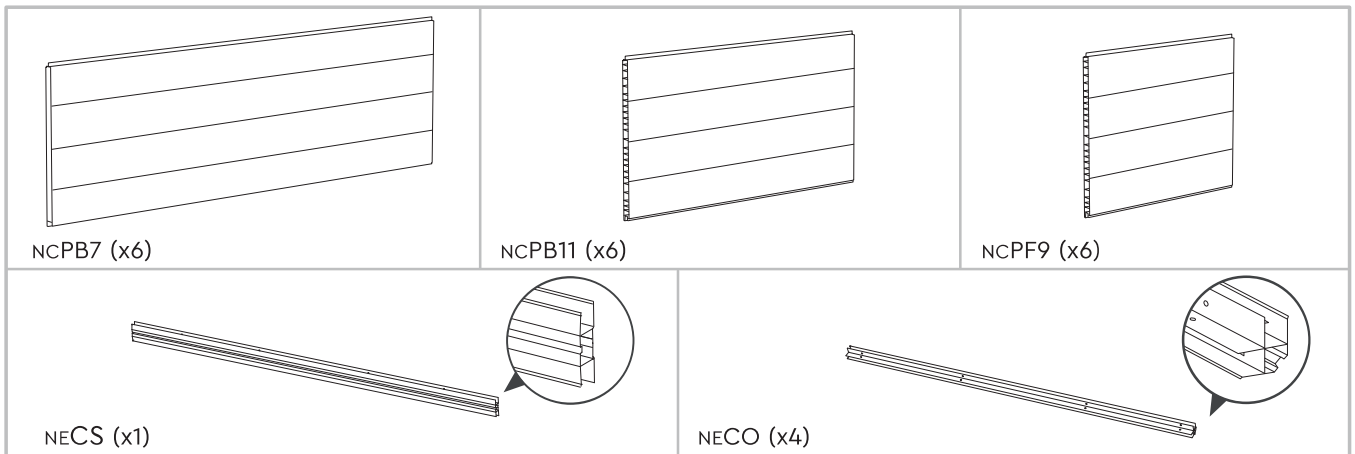

WALL PARTS | PIÈCES DES MURS | PARTES DE LAS PAREDES | WANDELEMENTE | MUURONDERDELEN | COMPONENTI DELLE PARETI | PAINÉIS LATERAIS



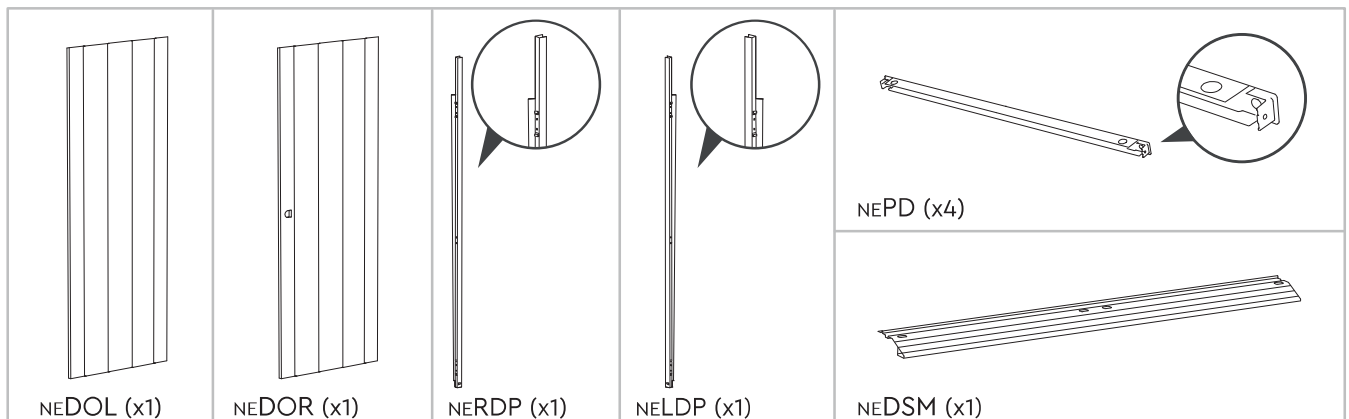



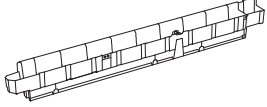
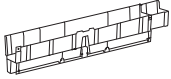
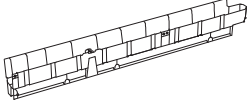
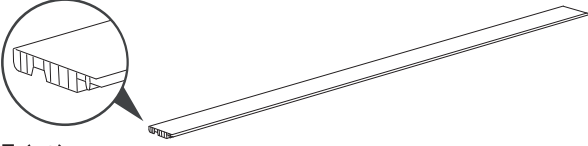
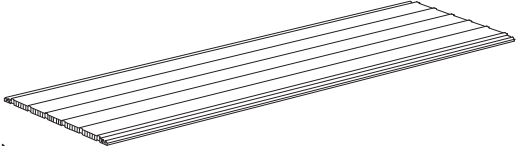

DOOR PARTS | PIÈCES DE LA PORTE | PARTES DE LA PUERTA | TÜRELEMENTE | DEURONDERDELEN | COMPONENTI DELLA PORTA | PEÇAS DAS PORTAS

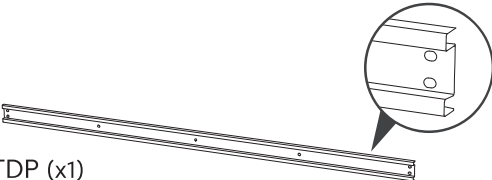
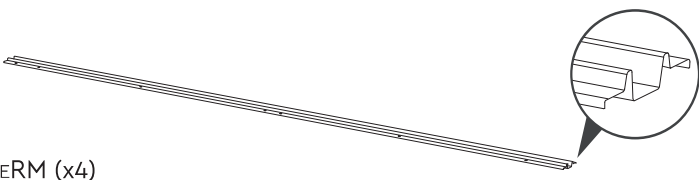
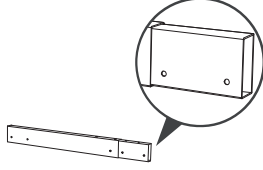
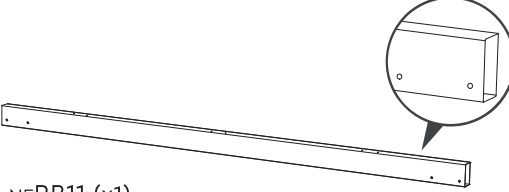
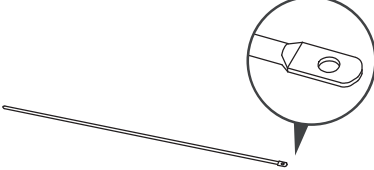

ROOF PARTS | PIÈCES DU TOIT | PARTES DEL TECHO | DACHELEMENTE | DAKONDERDELEN | COMPONENTI DEL TETTO | PEÇAS DO TELHADO

 NELC (x1)	 NECE (x2)	 NERC (x1)
 NELD (x1)	 NEDE (x2)	 NERD (x1)
 NEPRE (x2)		 NEPR (x5)



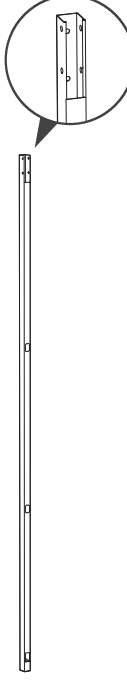



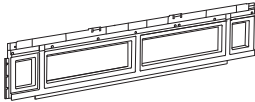
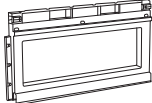
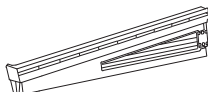
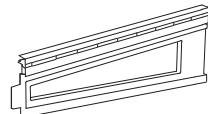
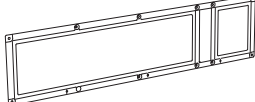
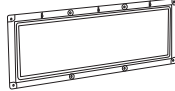
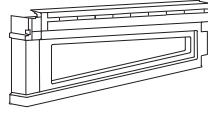
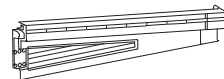
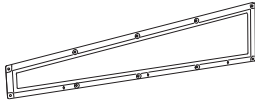



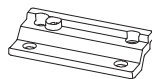
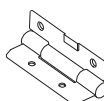

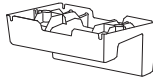
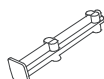
METAL PARTS | PIÈCES MÉTALLIQUES | PIEZAS METÁLICAS | METALLTEILE | METALEN DELEN | COMPONENTI IN METALLO | PARTES METÁLICAS

 NETDP (x1)	 NERM (x4)				
 NEBC1 (x2)	 NERB11 (x1)	 NEMB (x2)			
 NWDSO (x2)	 NWDSI (x1)	 NWDSW (x1)	 NEFFM (x1)	 NEBPM (x1)	 NESM2 (x2)

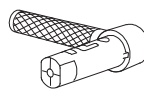

WINDOW PARTS | PIÈCES DE LA FENÊTRE | PARTES DE LA VENTANA | FENSTERELEMENTE | VENSTERONDERDELEN | COMPONENTI DELLE FINESTRE | PEÇAS DA JANELA

 NEFF (x1)	 NEFE (x2)	 NEBLT (x1)	 NELT (x1)
 NEGR (x2)	 NEGE (x2)	 NERT (x1)	 NEBRT (x1)
 NEGT (x2)			

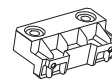
SMALL PARTS | PETITES PIÈCES | PARTES PEQUEÑAS | KLEINTEILE | KLEINE ONDERDELEN | MINUTERIA | PEÇAS PEQUENAS

 NEDS (x1)	 NEDH (x6)	 NEPL	 NERA (x4)	 NUHF (x2)
 NUHG (x2)	 NUHH (x2)	 NUHB (x1)	 NUHA (x1)	 NUHC (x1)
 NUHD (x1)	 NUHE (x1)	 NEDPC (x2)	 NES9 (x2)	 NWRK (x5)
		 NEMRC (x2)		

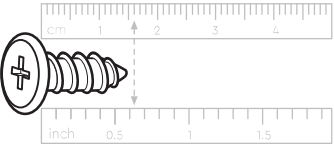
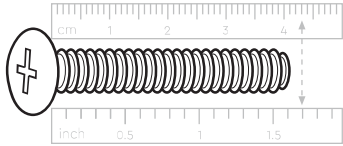
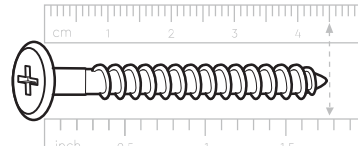
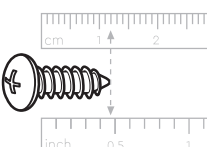
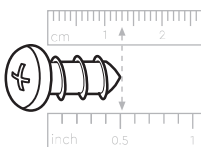
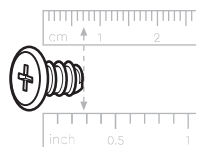
SCREWS | VIS | TORNILLOS | SCHRAUBEN | SCHROEVEN | VITI | PARAFUSOS

 sc15 (x328) 16 mm / 0.63"	 sc8 (x13) 43 mm / 1.69"	 s45b (x36) 45 mm / 1.77"
 s13b (x77) 12 mm / 0.47"	 scw1 (x48) 12.7 mm / 0.5"	 sc7t (x12) 7 mm / 0.28"
		 scn8 (x13)

Packaging may contain some additional small parts for use as spare parts | L'emballage peut contenir de petites pièces supplémentaires à utiliser comme pièces de rechange | El envoltorio puede contener algunas piezas pequeñas adicionales que se pueden utilizar como repuestos | In der Verpackung können kleine Zusatztteile enthalten sein, die als Ersatzteile genutzt werden können | De verpakking kan een aantal kleine extra onderdelen bevatten, die als reserveonderdeel gebruikt kunnen worden | L'imballo potrebbe contenere piccoli componenti supplementari da utilizzare come ricambistica | A embalagem pode conter algumas pequenas peças adicionais para utilização como peças de reposição

NOTE: Due to variations in production, the actual assembled size may vary slightly from the specified dimensions.
REMARQUE: En raison de variantes dans la production, la taille de montage réelle peut différer quelque peu des dimensions indiquées.
NOTA: debido a las variaciones en la producción, el tamaño real al montarlo puede variar ligeramente con respecto a las dimensiones especificadas.
BITTE BEACHTEN: Aufgrund von Abweichungen in der Herstellung kann die tatsächliche Größe leicht von den angegebenen Maßen abweichen.
LET OP: vanwege afwijkingen in de productie kan de werkelijke afmeting na montage een klein beetje afwijken van de opgegeven afmetingen
NOTA: A causa di variazioni nella produzione, le dimensioni effettive del prodotto assemblato potrebbero variare leggermente da quelle indicate.
NOTA: Devido a variações na produção o tamanho real da montagem poderá variar ligeiramente das dimensões especificadas.