

EAN : 3276007961058 - 3276007961027 - 3276007961041
 Adeo Key : 95420531 - 95420521 - 95420530

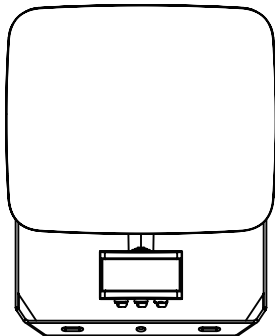

2/2



FR - Manuel d'Instructions

ES - Manual de Instrucciones

PT - Manual de Instruções

IT - Manuale di Istruzioni

EL - Εγχειρίδιο Οδηγιών

PL - Instrukcja Obsługi

UA - Інструкція з Експлуатації

RO - Manual de Instrucțiuni

BR - Manual de Instrução

NL - Handleiding

DE - Anleitung Handbuch

EN - Instructions Manual

*Année de garantie / años de garantía / Ano de garantia / Anno di garanzia / Έτος εγγύησης / Rok gwarancji /
 Гарантіяроків / Anul de garanție / Anos de garantia / Garantiejaar / Jahr der Garantie / Year of guarantee

** réparable / reparabile / reparável / riparabile / διορθώσιμος / naprawiany / ремонтний / reparabil / reparaturfähig /
 reparável / herstelbaar / reparierbar / repairable



FR: assemblage / **ES:** ensamblaje / **PT:** montagem / **IT:** assemblaggio /
EL: συναρμολόγηση / **PL:** montaż / **UA:** збірка / **RO:** asamblare /
BR: montagem / **NE:** samenstelling / **DE:** Montage / **EN:** assembly



FR: Utilisation / **ES:** Uso / **PT:** Utilização / **IT:** Utilizzo
EL: Χρήση / **PL:** Użycie / **UA:** Використання / **RO:** Utilizare / **BR:** Utili-
 zação / **NE:** Gebruik / **DE:** Verwendung / **EN:** Use





1 / 2

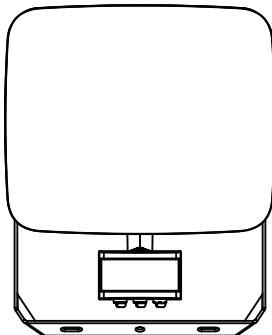

FR -Ce produit contient 1 source lumineuse de classe d'efficacité énergétique C. (EU) 2019/2015
 ES -Este producto contiene 1 fuente de luz de clase de eficiencia C. (EU) 2019/2015
 PT- Este produto contém 1 fonte de luz de eficiência energética de classe C. (EU) 2019/2015
 IT -Questo prodotto contiene 1sorgente luminosa di classe di efficienza energetica C. (EU) 2019/2015
 EL -Αυτό το προϊόν περιέχει πηγή φωτός κατηγορίας ενεργειακής απόδοσης C. (EU) 2019/2015
 PL -Niniejszy produkt zawiera źródło światła klasy efektywności energetycznej C. (EU) 2019/2015
 UA -Цей продукт містить джерело світла класу енергоєфективності C. (EU) 2019/2015
 RO -Acest produs conține o sursă de lumină cu clasă de eficiență energetică C. (EU) 2019/2015
 BR -Este produto contém 1 fonte de luz de classe de eficiência energética C. (EU) 2019/2015
 NL -Dit product omvat een lamp van de energie-efficiëntieklasse C (EU) 2019/2015
 DE -Dieses Produkt enthält 1 Lichtquelle der Energieeffizienzklasse C. (EU) 2019/2015
 EN -This product includes 1 light source of the energy efficiency class C. (EU) 2019/2015

LED Reference : HT-KANTI-20W-PIR-LS HT-KANTI-30W-PIR-LS HT-KANTI-50W-PIR-LS



EAN	 Max W	LED Reference	Projected	Weight	Dimension(L x W x H)
3276007961058	20	HT-KANTI-20W-PIR-LS	0.0155m ²	0.360kg	12.8x7.56x17.2cm
3276007961027	30	HT-KANTI-30W-PIR-LS	0.0220m ²	0.465kg	15.2x6.9x20.0cm
3276007961041	50	HT-KANTI-50W-PIR-LS	0.0356m ²	0.660kg	19.7x6.66x24.1cm

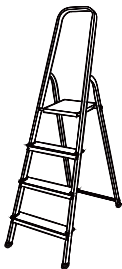
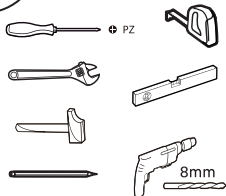

- A  x2
- B  x2
- C  x2

A: st5.5x35mm

B: Ø8x40mm

C: Ø16-Ø5mm

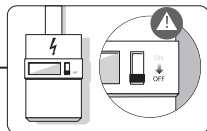

1

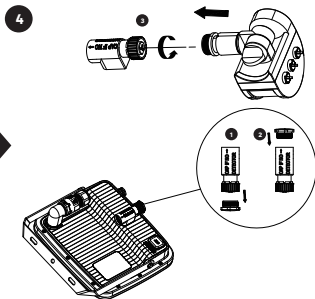
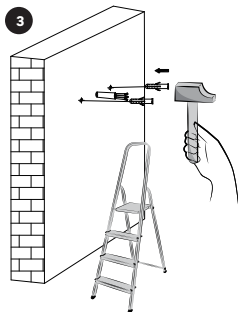
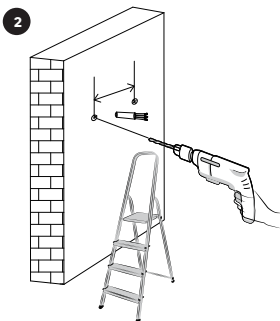
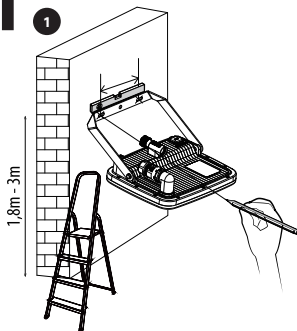

FR - Utiliser des vis et des chevilles adaptées à votre support. / **ES** - Utilice tacos y tornillos adecuados al soporte. / **PT** - Utilize buchas e parafusos adequado ao seu suporte. / **IT** - Utilizzare viti e tasselli adatti per il retro. / **EL** - Χρησιμοποιήστε βίδες και βύσματα που ταιριάζουν στην επιφάνεια στήριξης. / **PL** - Należy użyć śrub i kołków odpowiednich dla podłoża. / **UA** - Використовуйте гвинти та шканти, призначені для задньої поверхні. / **RO** - Utilizați șuruburi și dibluri adecvate pentru suportul dvs. / **BR** - Use parafusos e buchas adequados para seu suporte. / **NL** - Gebruik schroeven en pluggen die geschikt zijn voor uw ondergrond. / **DE** - Verwenden Sie für Ihre Unterlage geeignete Schrauben und Dübel. / **EN** - Use screws and dowels suited to your backing.

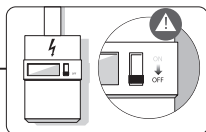

1

5

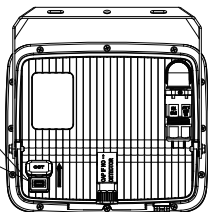
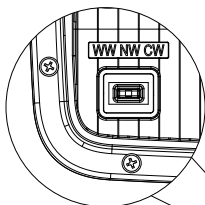

Colour Temperature (CCT) setting	
	2700K
	4000K
	6500K

6

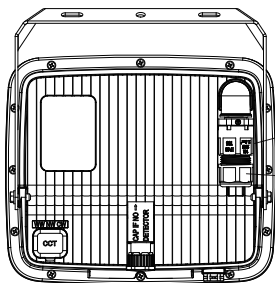

2

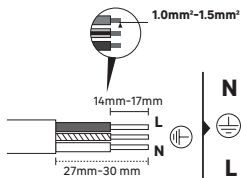
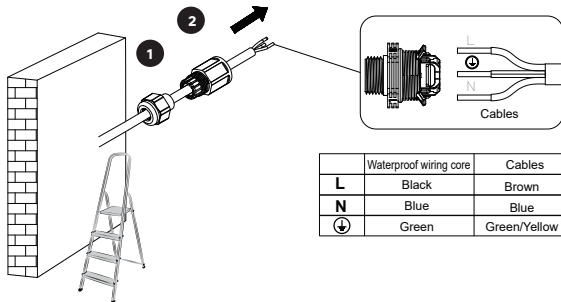

- N** = Bleu/Azul/Azul/Blu/Μπλε/Niebieski/Синий/Albastru/ Blauw/Blau/**Blue**
 = Vert et jaune/Verde y amarillo/Verde e giallo/Πράσινο και κίτρινο /Zielony i żółty /Зеленый и жовтий/Verde-galben/Verde e amarelo/Groen en geel/Grün und gelb/**Green and yellow**
L = Marron/Marrón/Castanho/Marrone/Καφέ/Brazowy/Коричневий/Μαρο/Marrom/bruin/Braun/**Brown**

3

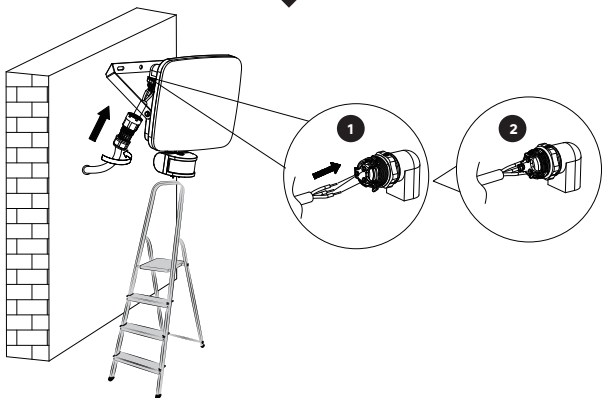

4

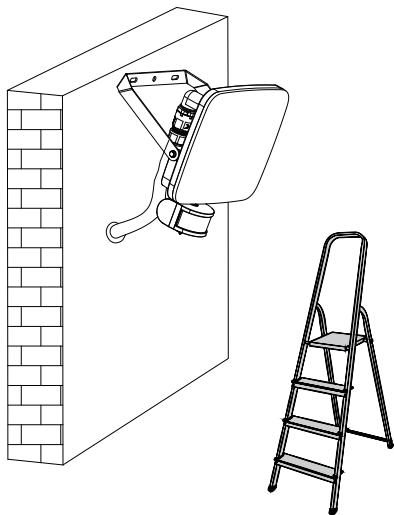

5

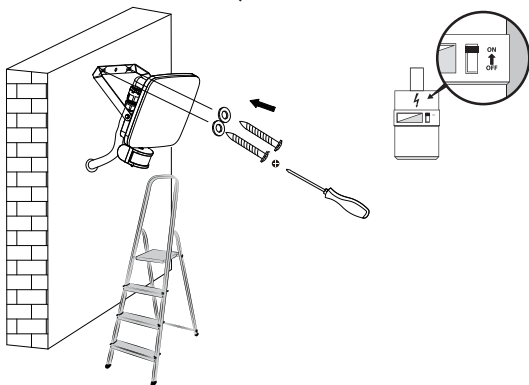

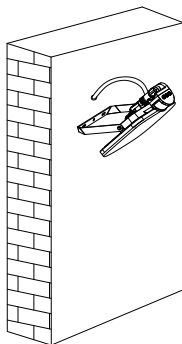
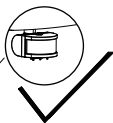
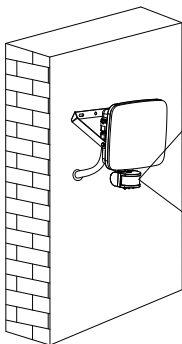
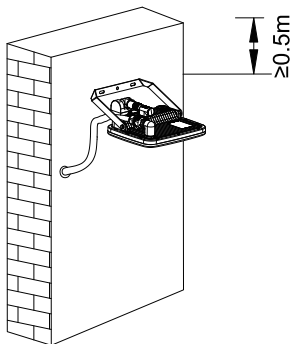
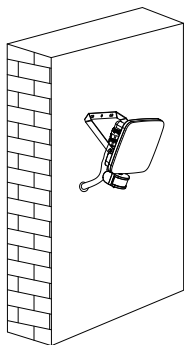

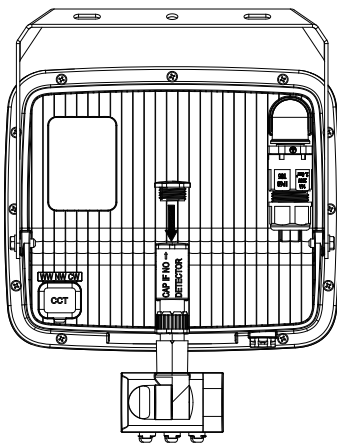
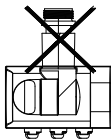
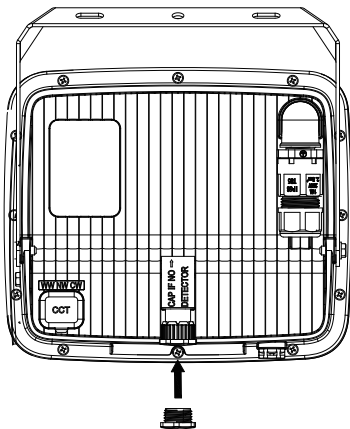



1

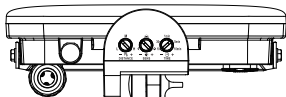

2

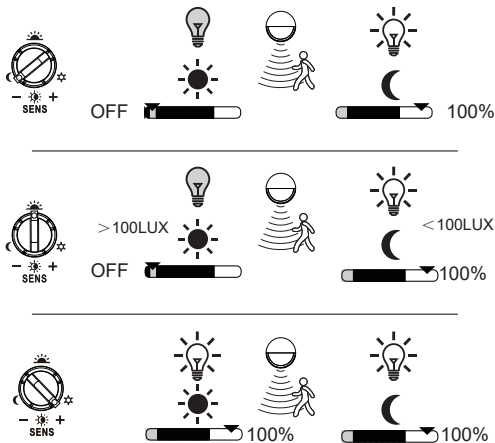
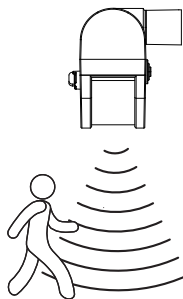
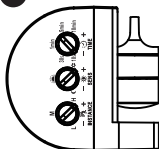



2₁

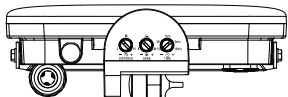

2

$140^{\circ} \pm 20^{\circ}$
($< 25^{\circ}C$)

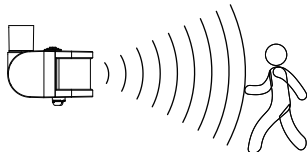
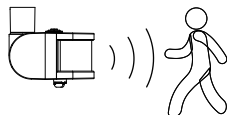
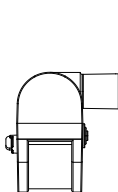
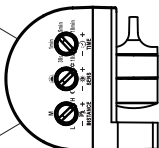

Distance:MAX 10M



3.1

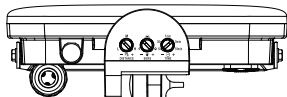

2

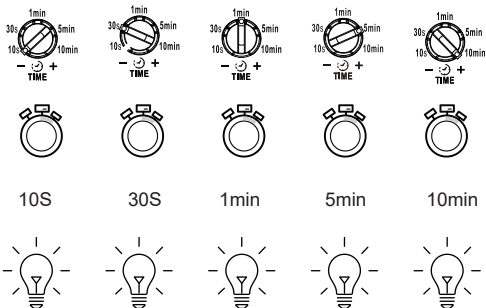
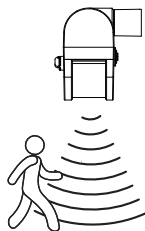
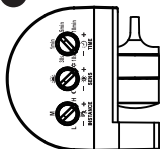



4

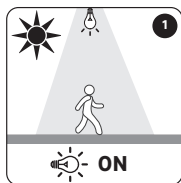
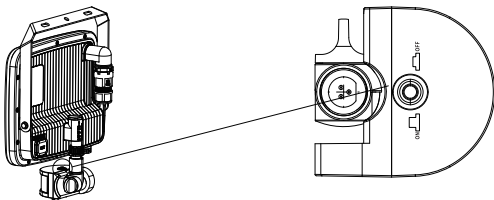

ON

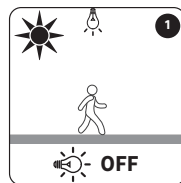
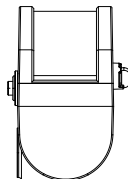

OFF

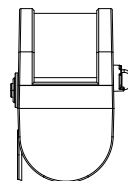

FR : S'allume le jour et la nuit après détection / ES : Se enciende de día y de noche después de la detección / PT : Liga-se de dia e de noite após detecção / IT : Si accende di giorno e di notte dopo il rilevamento / PL : Włącza się w dzień i w nocy po wykryciu / EL : Ανάβει μέρα και νύχτα μετά την ανίχνευση / UA : Вмикається вдень і вночі після виявлення / RO : Se aprinde ziua și noaptea după detectare / BR : Liga-se de dia e de noite após detecção / DE : Schaltet sich Tag und Nacht nach Erkennung ein / NL : Schakelt overdag en 's nachts in na detectie / EN : Turns on day and night after detection



Points de collecte sur www.quefairedemesdechets.fr
Privilégiez la réparation ou le don de votre appareil !

FR Traduction de la version originale du mode d'emploi / ES: Traducción de las Instrucciones originales / PT: Tradução das Instruções Originais / IT: Traduzione delle istruzioni originali / EL: Μετάφραση των πρωτότυπων οδηγιών / PL: Tłumaczenie instrukcji oryginalnej / UA: Переклад оригінальної інструкції / RO: Traducerea instrucțiunilor originale / BR: Tradução das Instruções Originais / DE: Übersetzung der Originalversion der Gebrauchsanweisung / Original Instructions.

Made in China
Країна походження: Китай

EU - ADEO Services - 135 Rue Sadi Carnot - CS00001 - 59790 RONCHIN - FRANCE

www.product-regulatory.adeoservices.com

UA-Виробник: ТОВ «Адео Сервісез С.А.»,
вул. Саді Карно, CS 00001, 59790 Роншен,
Франція. Імпортер, суб'єкт господарювання,
що відповідає за виконання гарантійних
зобов'язань: ТОВ «Леруа Мерлен Україна»,
04201 Україна, м. Київ, вул. Полярна 17А,
+380 44 498 46 00.

BR - IMPORTADO E DISTRIBUÍDO POR: LEROY
MERLIN COMPANHIA BRASILEIRA DE BRICOLA-
GEM CNPJ: 01.438.784/0001-05 Rua Pascoal
Pais, nº. 525, 6º andar, cj 61 a 64 - Vila Cordeiro,
São Paulo - SP CEP: 04581-060 CALM (Central
de Atendimento Leroy Merlin) Capitais
4020-5376 Demais Regiões 0800-0205376

ZA-Imported by Adeo South Africa (PTY) LTD
T/A Leroy Merlin, Hosted in Leroy Merlin
Fourways Store 35 Roos Street, Witkoppen
Ext 97, Sandton, 2191 Johannesburg, Gauteng,
South Africa. Tel: +27 10 493 8000 Email:
contact@leroymerlin.co.za.

