

## CLIMA ODYSSEA BIOCLIMATIC MANUAL

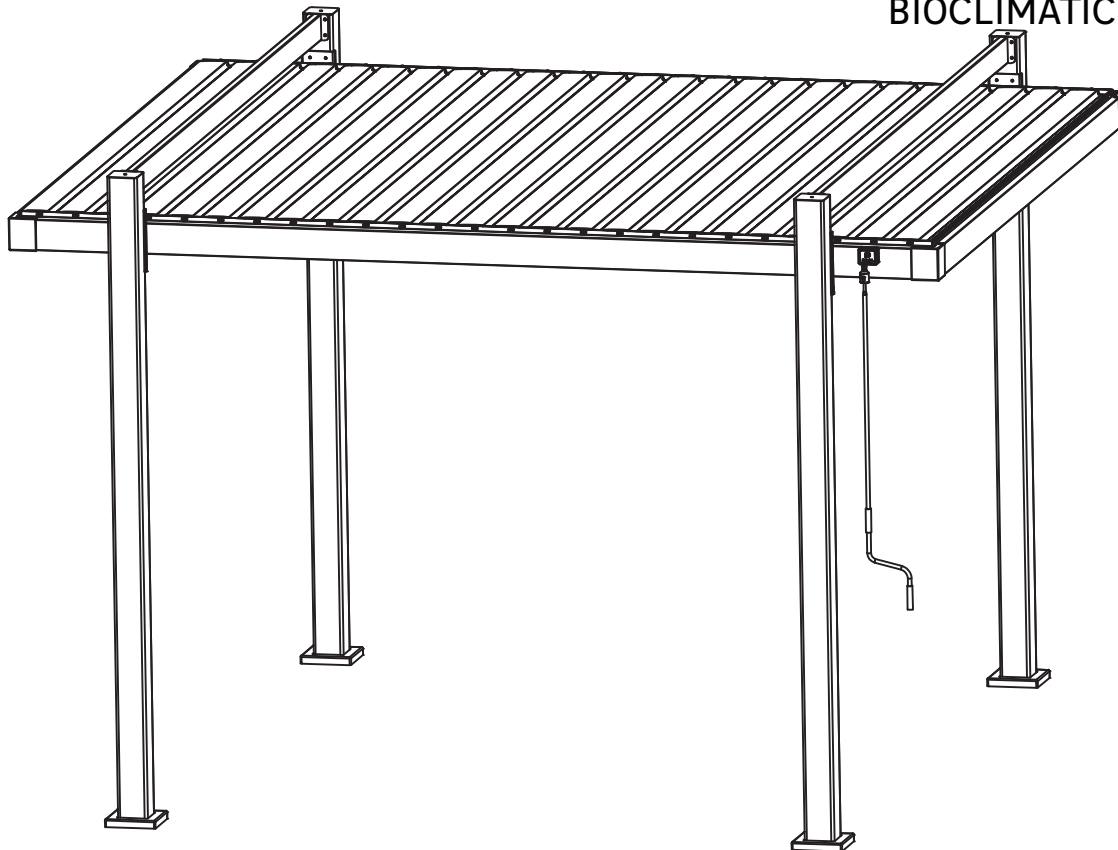

EAN : 3276007947847/3276007947861/3276007947816

MATRIX ID : 2026R09P13-0001/2026R09P13-0002/2026R09P13-0003

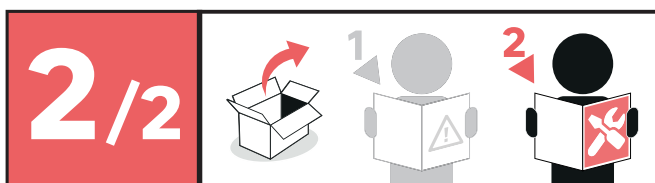

- |                                     |                                   |                                  |                                 |
|-------------------------------------|-----------------------------------|----------------------------------|---------------------------------|
| <b>FR</b> Manuel d'Instructions     | <b>ES</b> Manual de Instrucciones | <b>PT</b> Manual de Instruções   | <b>IT</b> Manuale di Istruzioni |
| <b>EL</b> Εγχειρίδιο Οδηγιών        | <b>PL</b> Instrukcja Obsługi      | <b>RO</b> Manual de Instrucțiuni | <b>BR</b> Manual de Instruções  |
| <b>UA</b> Інструкція з експлуатації | <b>HE</b> מדריך הוראות            | <b>AR</b> كتيب التعليمات         | <b>EN</b> Instructions Manual   |
| <b>NL</b> Handleiding               | <b>NO</b> Instruksjonsmanual      | <b>DA</b> Instruktionsbog        | <b>SV</b> Instruktionsbok       |
| <b>DE</b> Gebrauchsanweisung        | <b>SL</b> Navodila za uporabo     | <b>HR</b> Upute za uporabu       | <b>SQ</b> Manuali i udhëzimeve  |

Traduction de la version originale du mode d'emploi / Traducción de las Instrucciones originales / Tradução das Instruções originais / Traduzione delle istruzioni originali / Μετάφραση των πρωτότυπων οδηγιών / Tłumaczenie instrukcji oryginalnej / Переклад оригінальної інструкції / Traducerea instrucțiunilor originale / תרגום של הגרסה המקורית של הוראות השימוש / ترجمة النسخة الأصلية لتعليمات الاستعمال / Tradução das Instruções originais / Vertaling van de oorspronkelijke versie van de gebruiksaanwijzing / Oversettelse av originalversjonen av brukerhåndboken / Oversættelse af originalversionen af brugsanvisningen / Översättning av originalversionen av instruktionsboken / Übersetzung der Originalversion der Gebrauchsanweisung / Prevod originalne različice navodila za uporabo / Prijevod izvorne verzije priručnika / Përkhimi i versionit origjinal të udhëzimeve për përdorimin / Original version of instruction manual

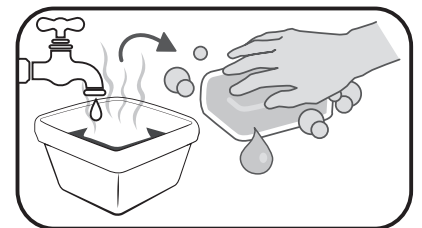
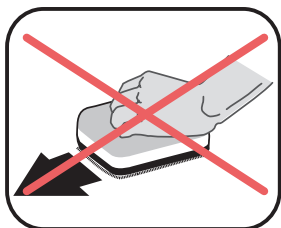
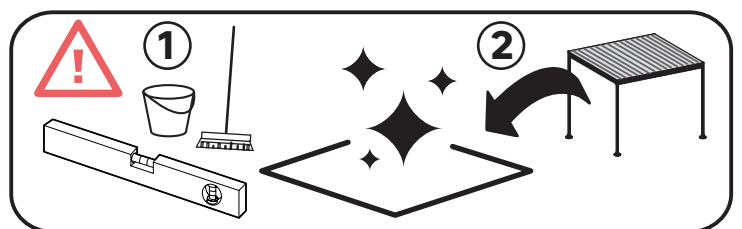
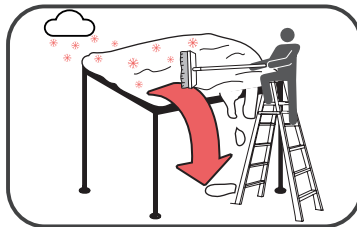
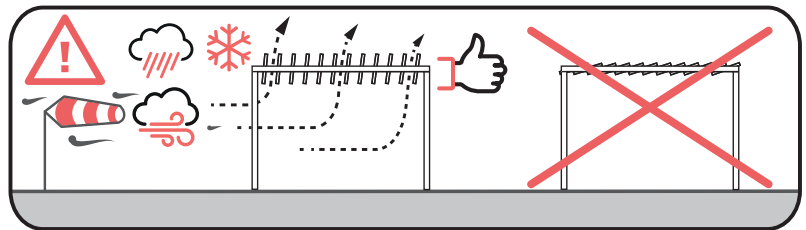
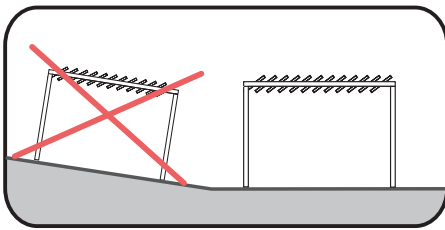
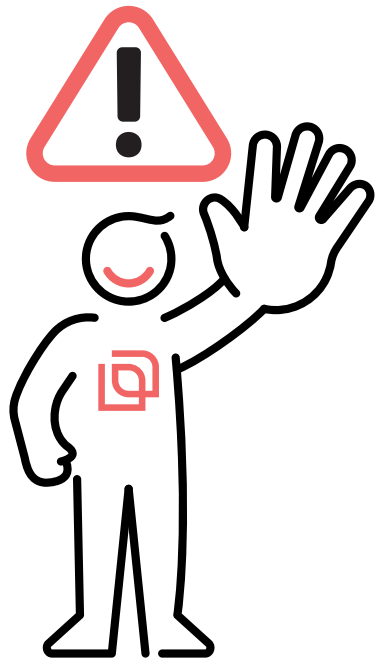



Pièces / Piezas / Partes  
/ Parti di ricambio /  
Ανταλλακτικά / Części /  
Деталі деталей / Piese /  
Peças / Parts

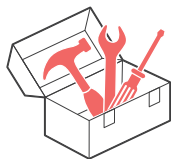

Outils / Herramientas /  
Ferramentas / Strumenti  
/ Εργαλεία / Narzędzia  
/ Інструменти /  
Instrumente /  
Ferramentas / Tools



Article non inclus /  
Artículo no incluído /  
Artigo não incluído /  
Articolo non incluso /  
Το στοιχείο δεν περιλαμβάνεται /  
Artykuł nie wliczony /  
Пункт не включено /  
Articol neîncclus /  
Item não incluído /  
Article not included



Montage / Montaje / Assembleia / Montaggio / Συναρμολόγηση / Montaż /  
Збірка / Asamblarea / Assembléia / Assembly



Utilisation / Utilice / Utilização / Utilizzo / Χρήση / Użyj / Утилізація / Utilizați  
/ Use / Use

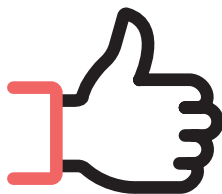

Etape décisive réussie / Paso decisivo con éxito / Passo decisivo bem  
sucedido / Un passo decisivo di successo / Επιτυχημένο αποφασιστικό βήμα /  
Udany, decydujący krok / Успішний вирішальний крок / Pas decisiv de  
succes / Etapa decisiva bem-sucedida / Successful decisive step

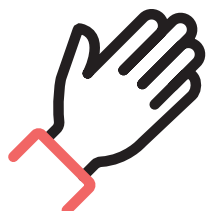

Pas besoin d'outil / No se necesitan herramientas / Não são necessárias  
ferramentas / Non sono necessari strumenti / Δεν απαιτούνται εργαλεία /  
Nie są wymagane żadne narzędzia / Інструменти не потрібні / Nu sunt  
necesare unelte / Não são necessárias ferramentas / No tools required

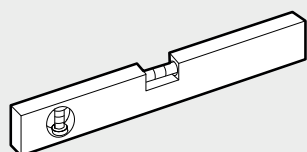
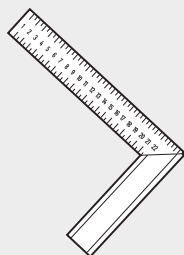
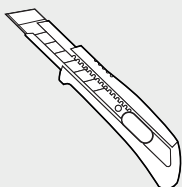
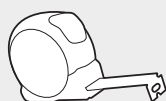
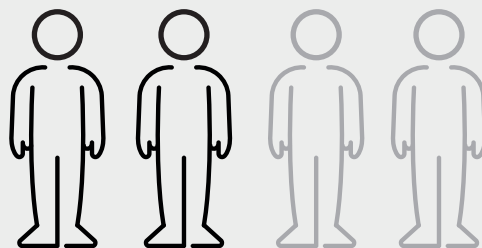
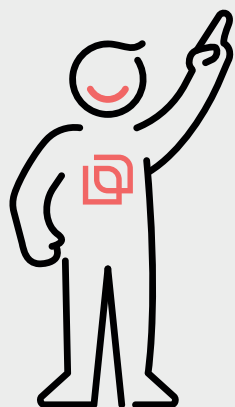
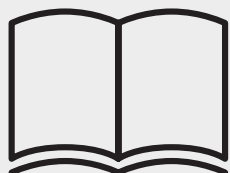

X2

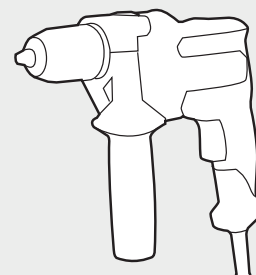
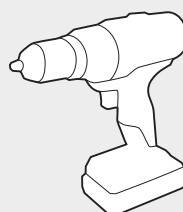
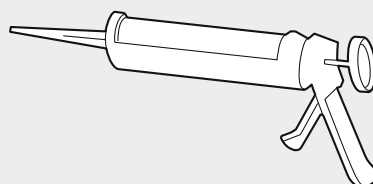
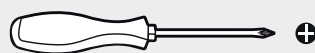
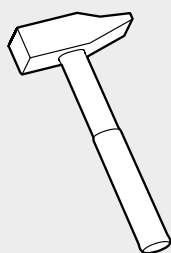



- FR Silicone transparent pour usage extérieur et support aluminium.
- ES Silicona transparente para exteriores y soporte de aluminio.
- PT Silicone transparente para utilização no exterior com suporte em alumínio.
- IT Silicone trasparente per uso esterno e su alluminio.
- EL Διαφανής σιλκόνη για εξωτερική χρήση και στήριξη αλουμινίου.
- PL Przezroczysty silikon do użytku zewnętrznego i wspornik aluminiowy.
- UA Прозорий силікон для зовнішнього застосування з алюмінієвою основою.
- RO Silicon transparent pentru utilizare în exterior și suport din aluminiu.
- BR Silicone transparente para uso externo e suporte de alumínio.
- EN Transparent silicone for outdoor use with aluminium bracket.



EE		M4	x8
GG		ST4.8*10	x50
CC		M4*12	x8
FF		M5*15	x8
DD		Ø8.8*10*M6*6	x25
HH		M5*18	x1
AA		M8*20	x16
BB		M6*20	x64
JJ		M6*60	x8

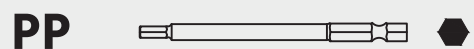
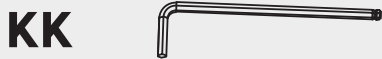



**A**  
2475 mm

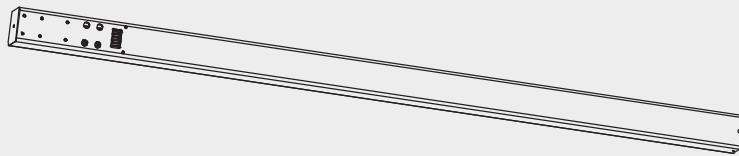

x4

**B**  
2970 mm

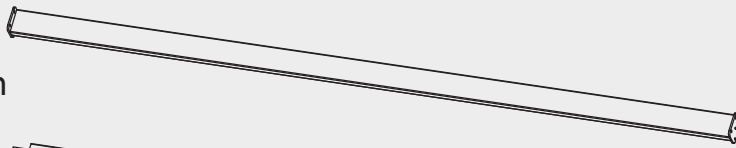

x2

**C**  
2960 mm

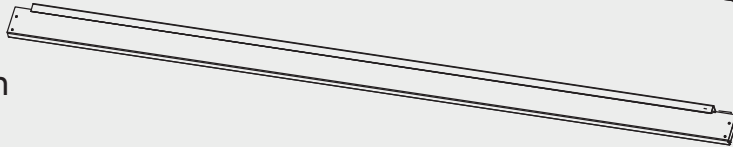

x2

**C1**  
3515 mm

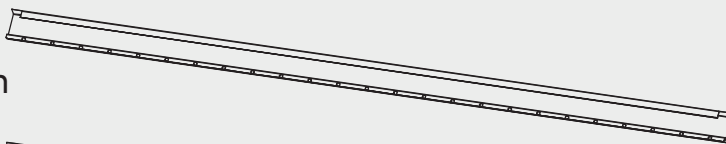

x1

**C2**  
3515 mm

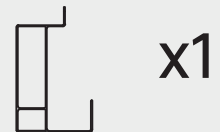
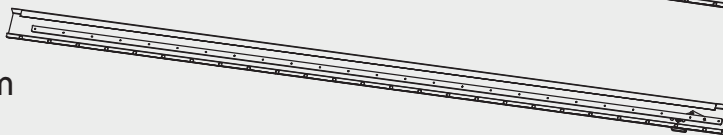

x1

**D**  
2825 mm



x25

**F**  
175 mm

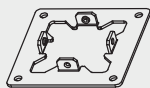

x4

**L**



x4

**G**  
195 mm

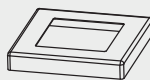

x4

**M**



x4

**H**



x1

**N**



x4

**J1**

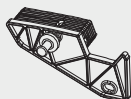

x25

**Q**



x50

**J2**



x25

**R**



x1

**K**



x4

**E** x1

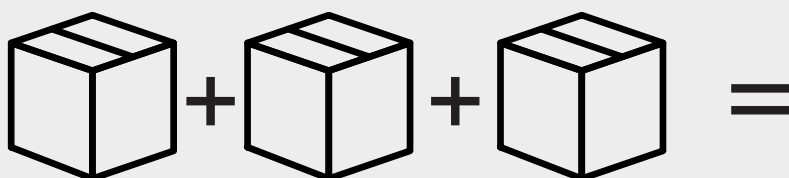

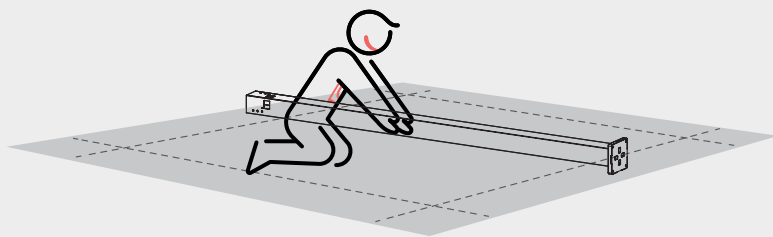
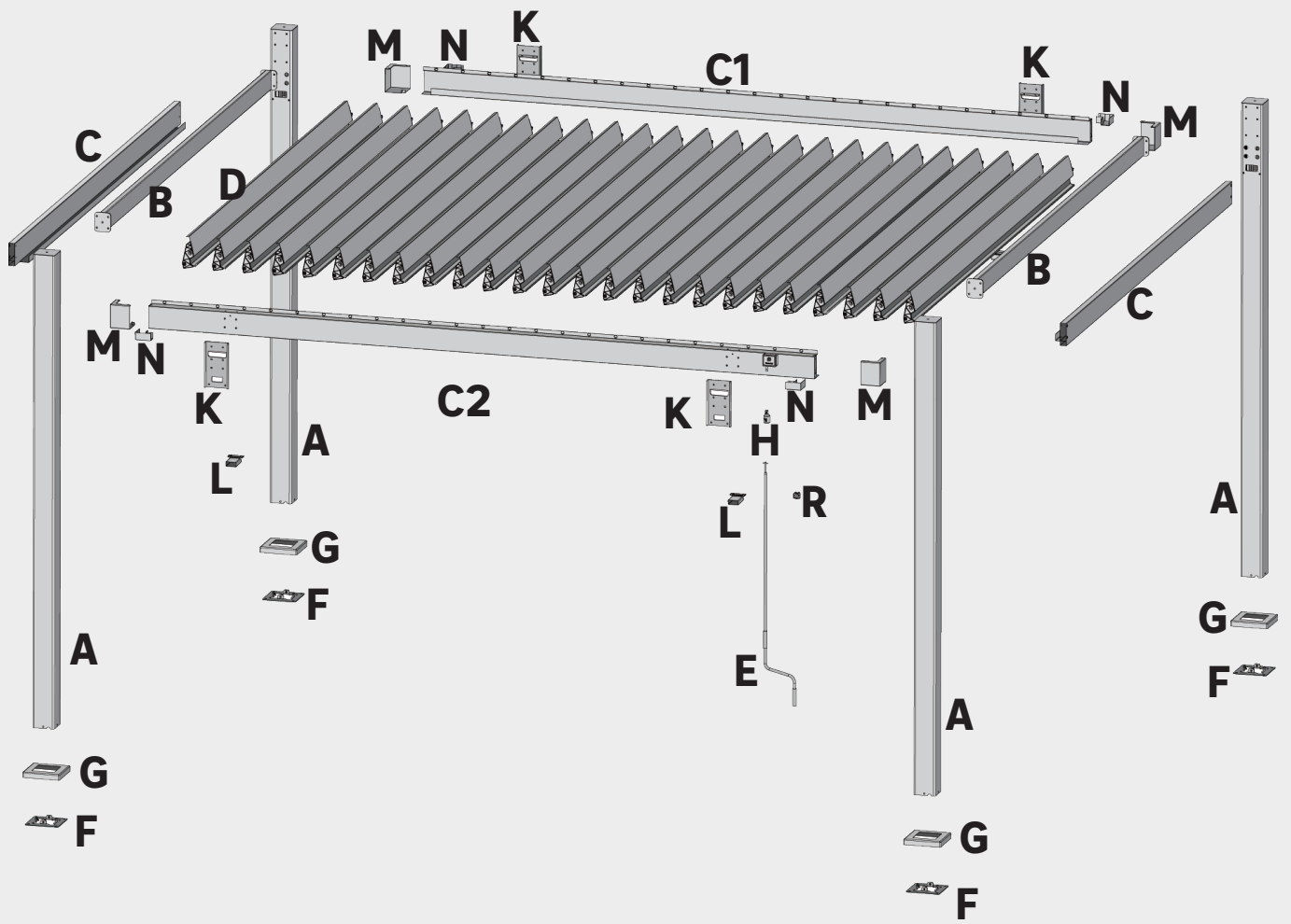

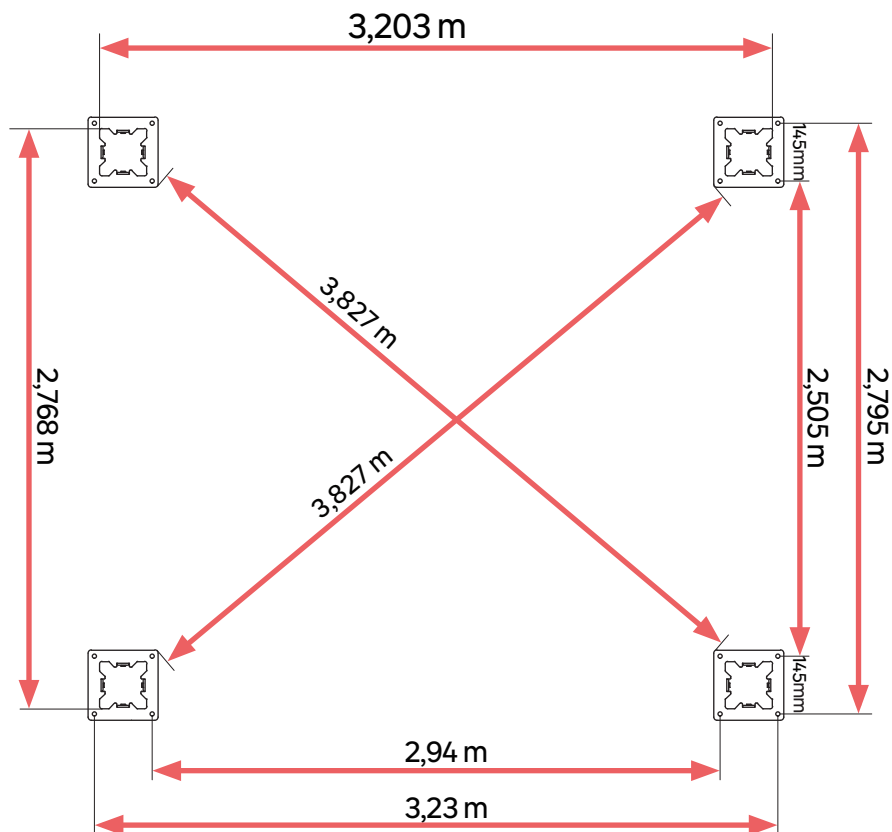
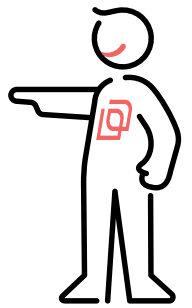
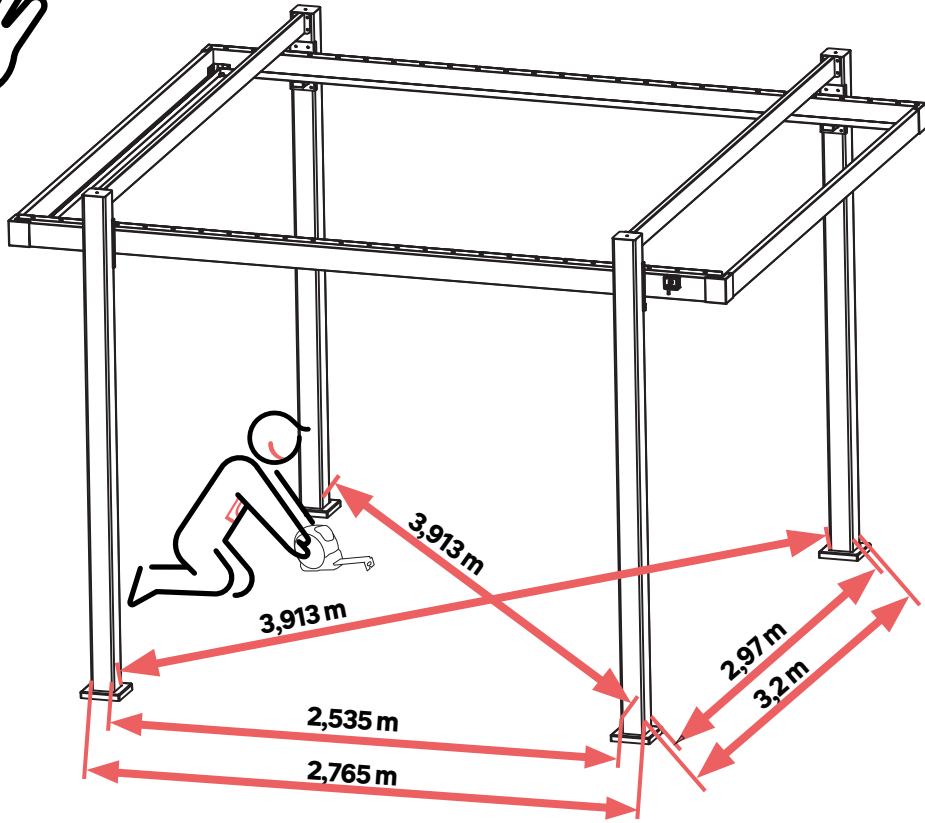
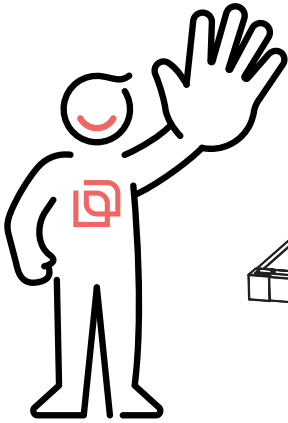
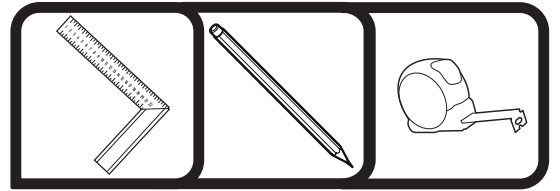
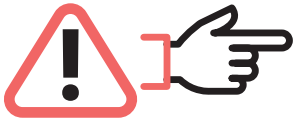

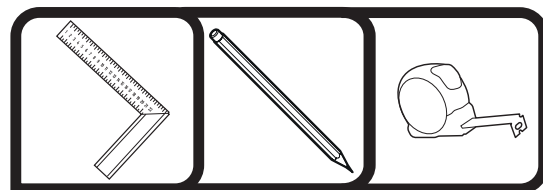

- FR Mesurez et tracez sur le sol et/ou sur le mur, les points de fixation à prévoir pour le perçage.
- ES Mida y marque en el suelo y/o en la pared los puntos de fijación que se utilizarán para taladrar.
- PT Medir e marcar no chão e/ou na parede os pontos de fixação a utilizar para a perfuração.
- IT Misurare e segnare sul pavimento e/o sulla parete i punti di fissaggio da utilizzare per la foratura.
- EL Μετρήστε και σημειώστε στο δάπεδο ή/και στον τοίχο τα σημεία στερέωσης που θα χρησιμοποιηθούν για τη διάτρηση.
- PL Zmierz i zaznacz na podłodze i/lub ścianie punkty mocowania, które zostaną użyte do wiercenia.
- UA Виміряйте та позначте на підлозі та/або стіні точки кріплення, які будуть використовуватися для свердління.
- RO Măsurăți și marcați pe podea și/sau perete punctele de fixare care urmează să fie utilizate pentru găurire.
- BR Meça e marque no piso e/ou na parede os pontos de fixação a serem usados para a perfuração.
- EN Measure and mark on the floor and/or wall the fixing points to be used for drilling.

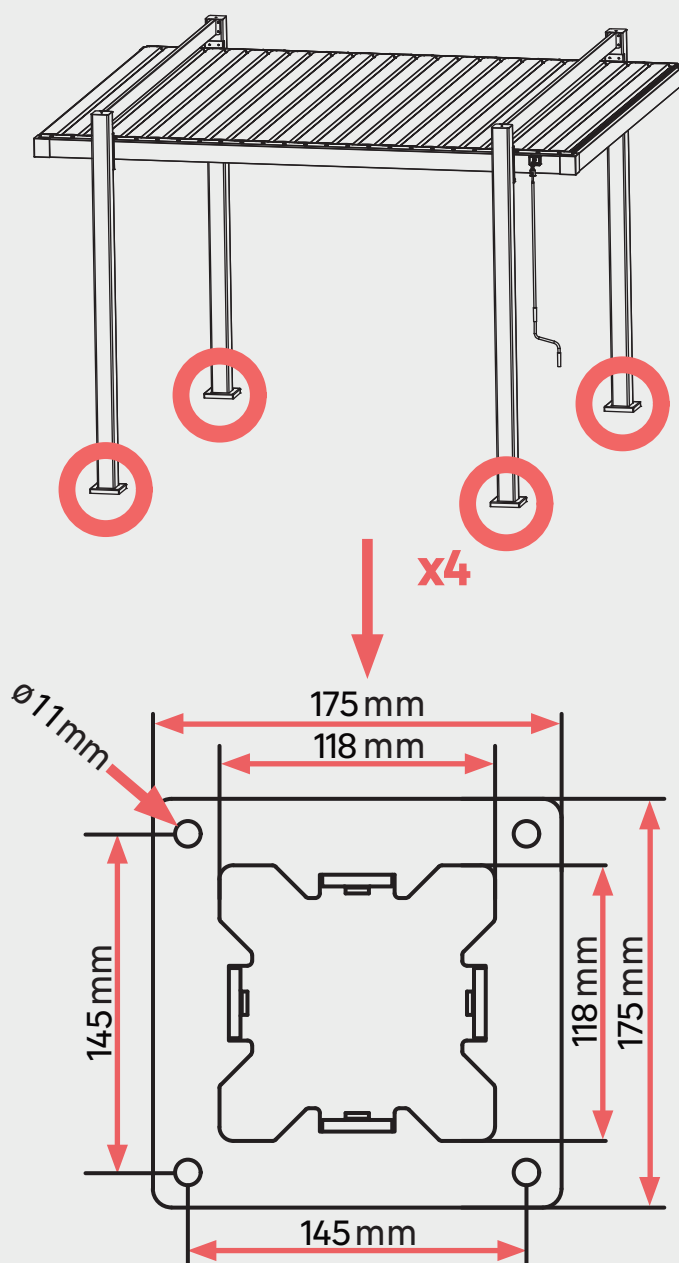



1

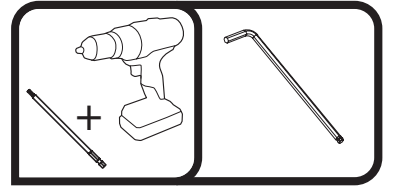

A x 4



F x 4

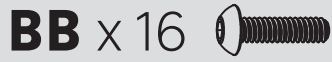

BB x 16



G x 4

1

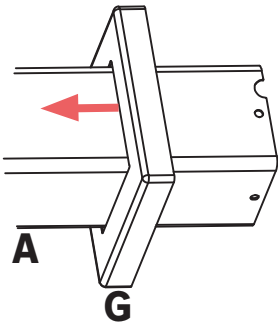

2

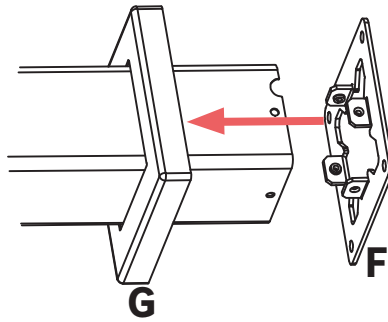

3

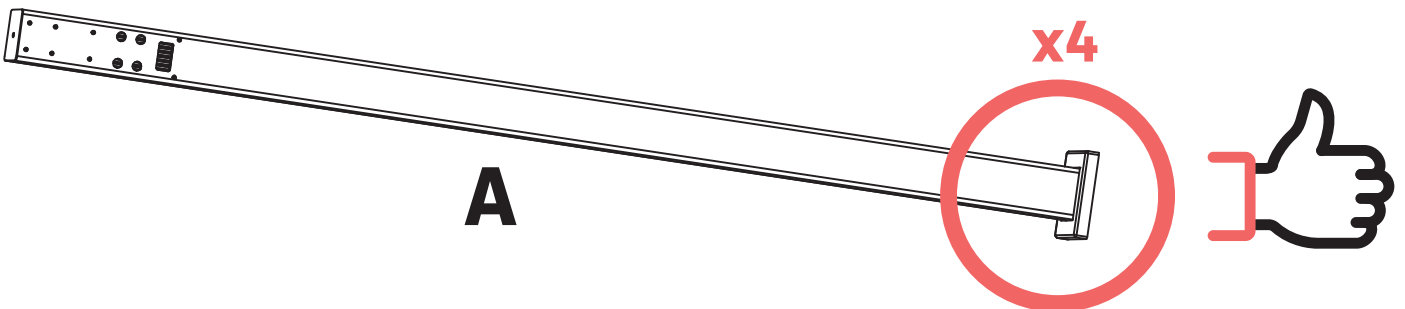
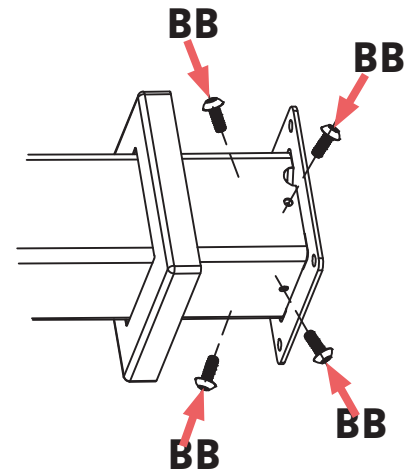

x4

A





# 2

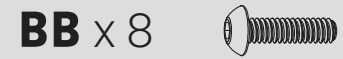
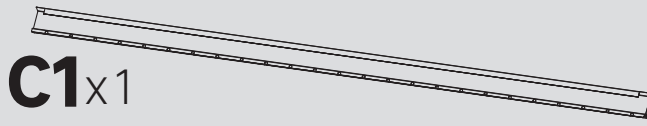
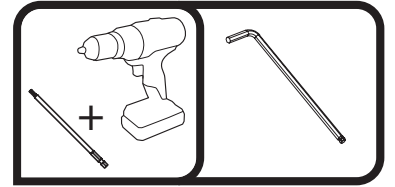

## 1

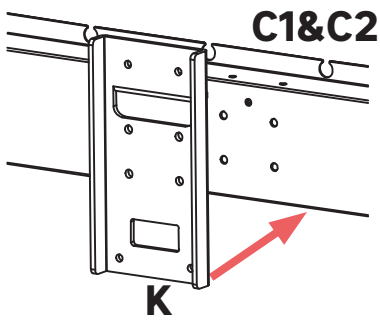

## 2

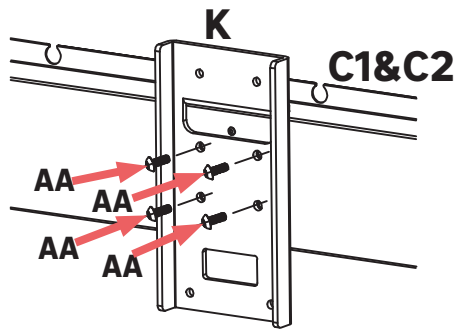

## 3

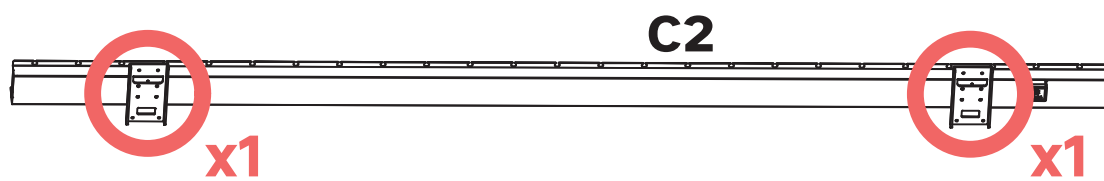
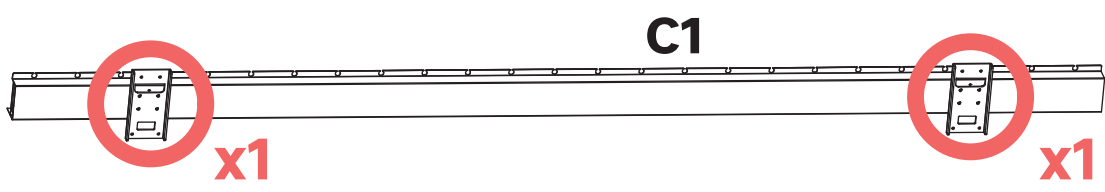
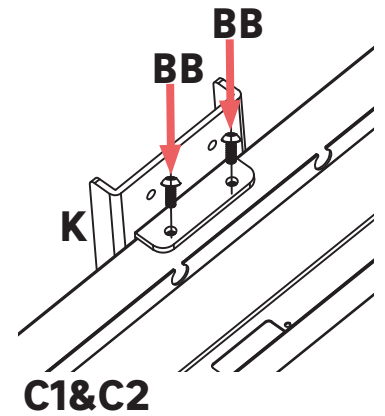



# 3

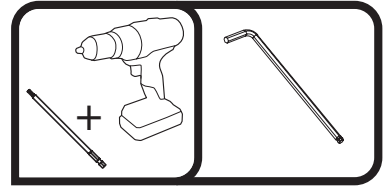

**BB** x8 

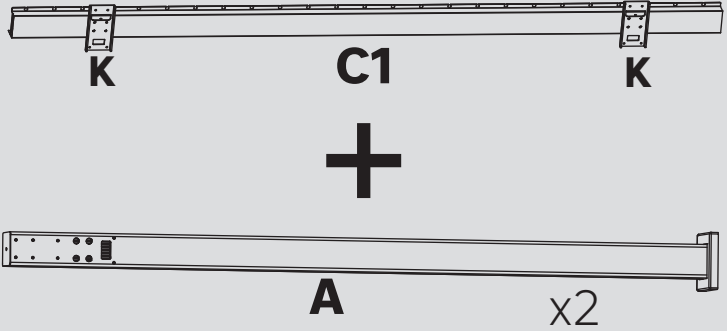

## 1

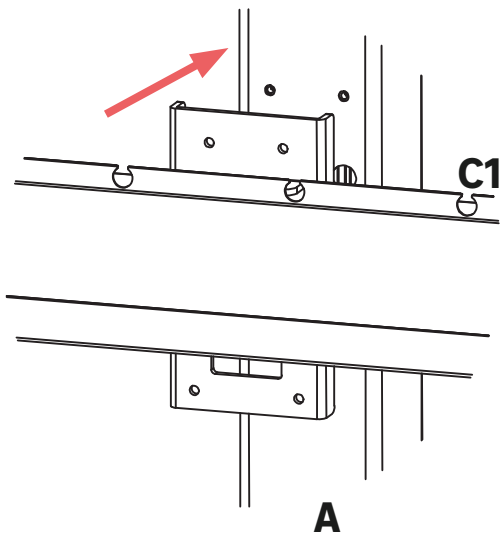

## 2

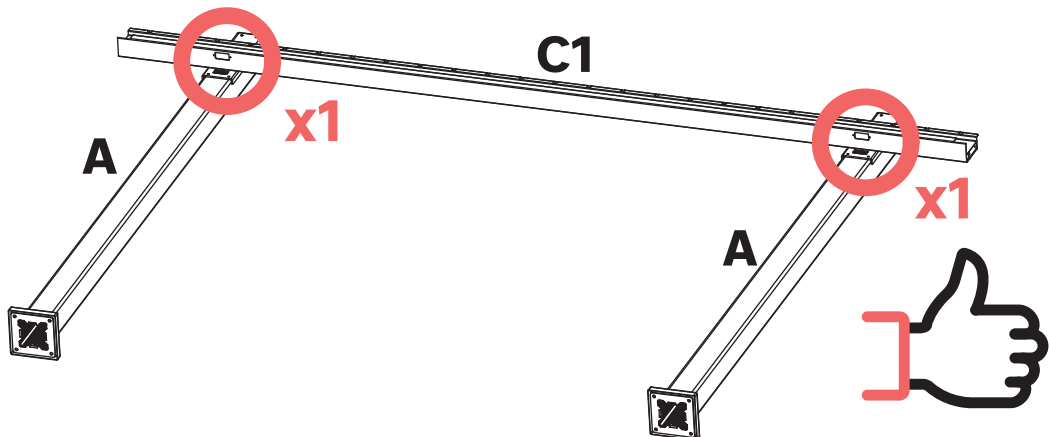
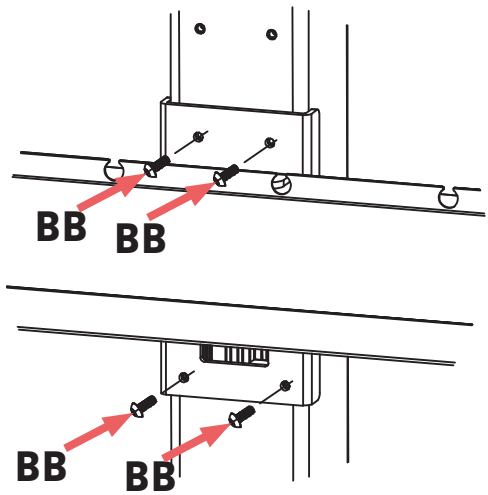



# 4

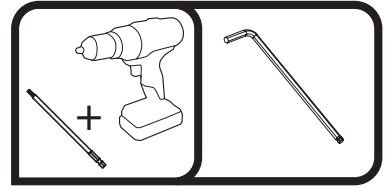

**BB** x8 



**C2**

**K**

**K**

+



**A**

x2

# 1

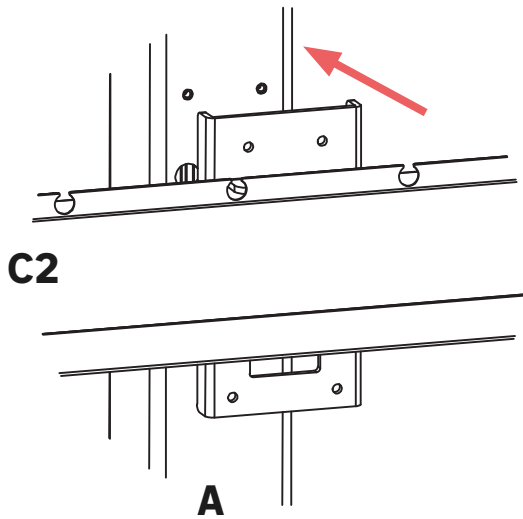

# 2

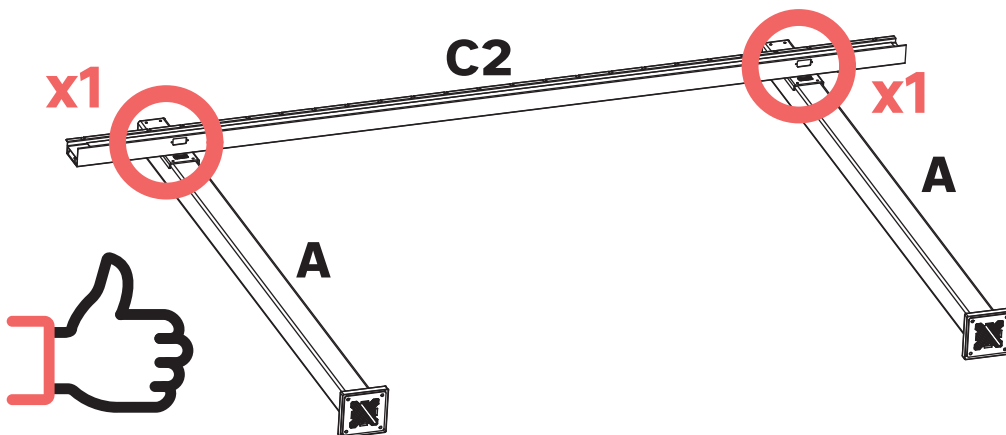
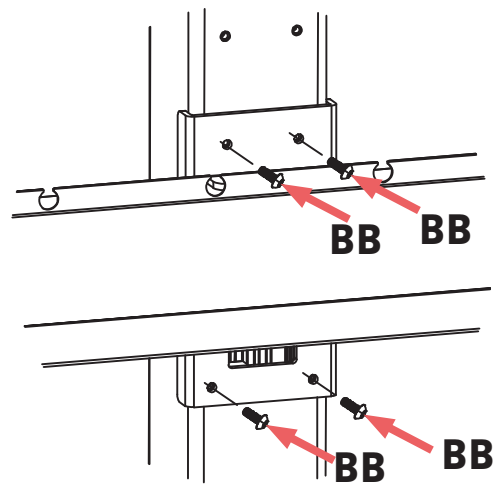

x1

**C2**

x1

**A**

**A**



5

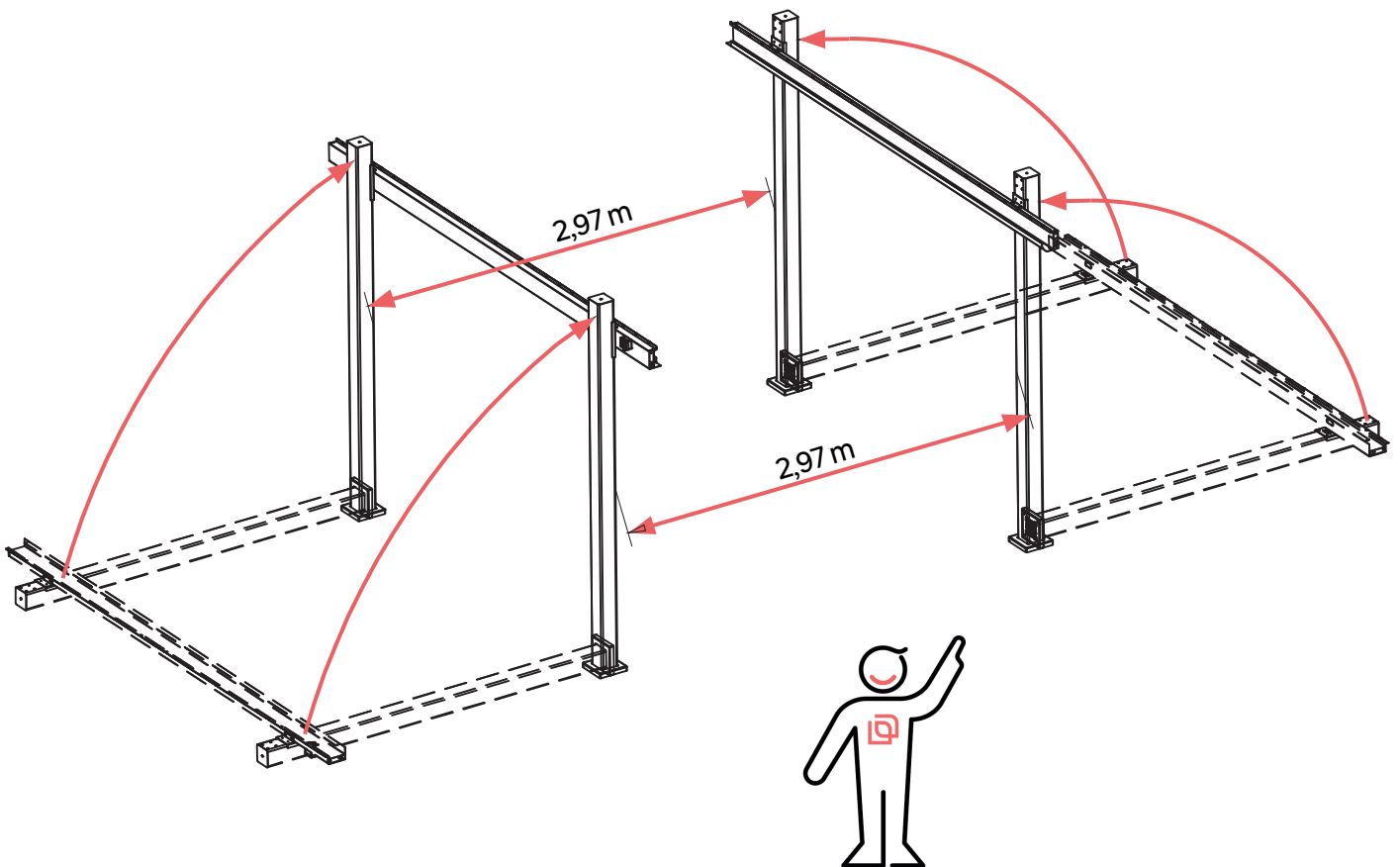
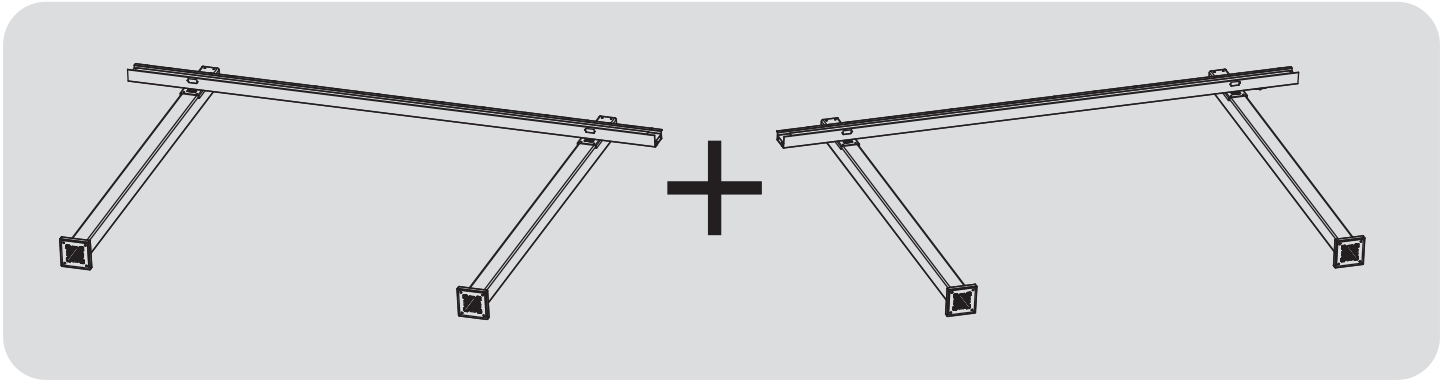
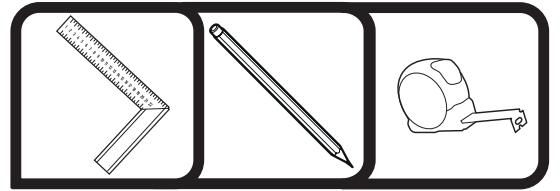



# 6

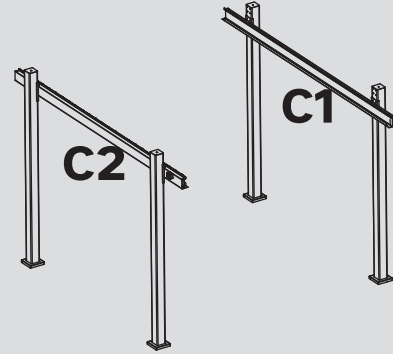
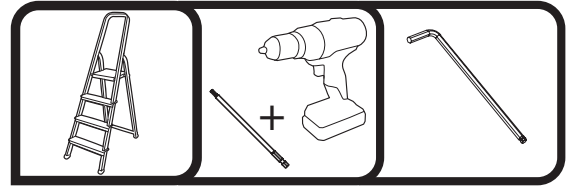

## 1

## 2

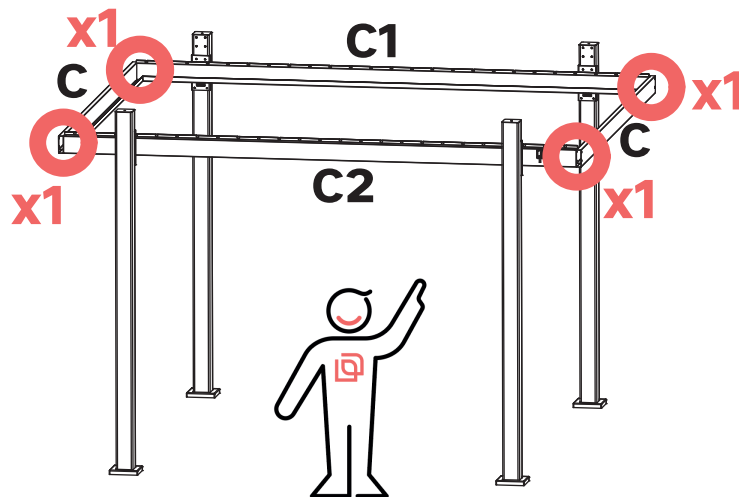
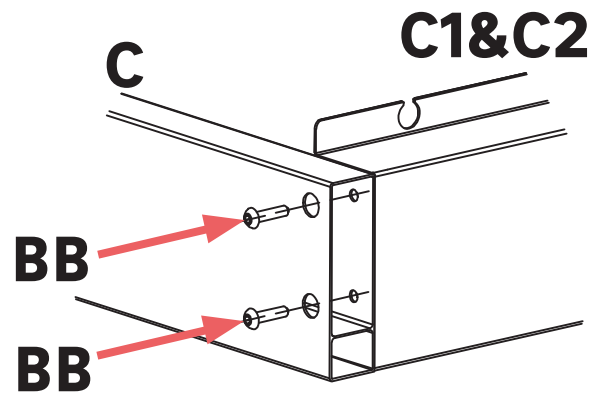
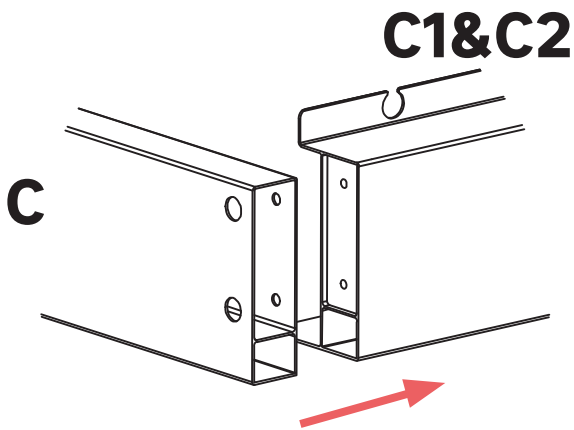



7

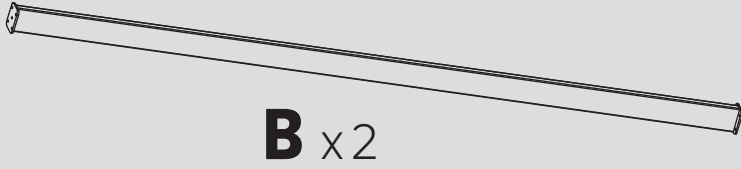
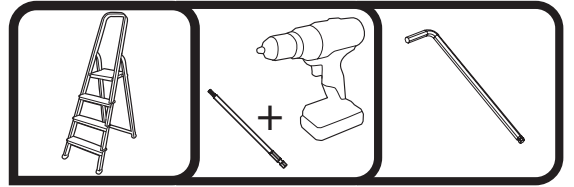

BB x 16

1

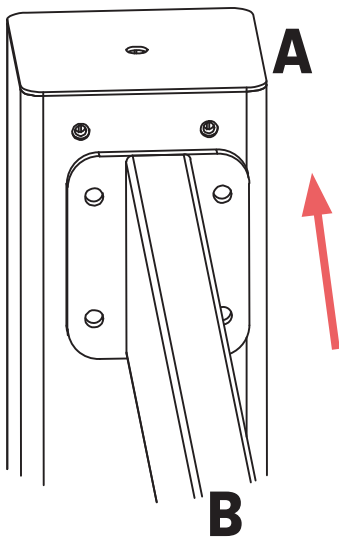

2

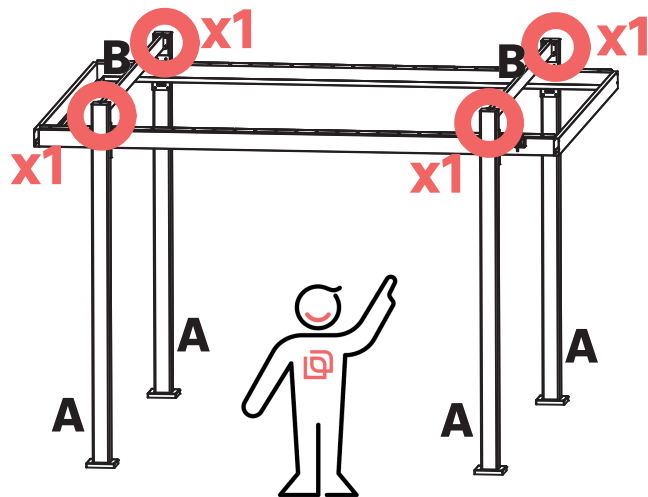
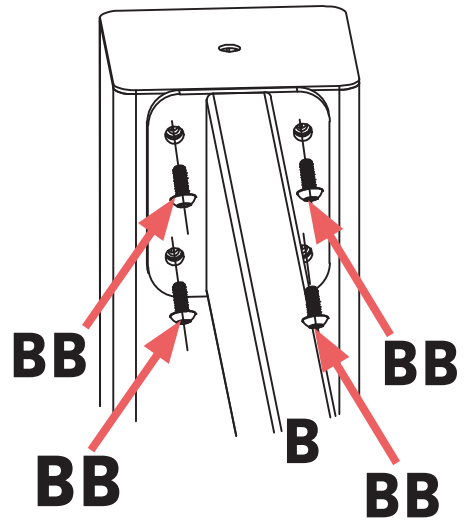



# 8

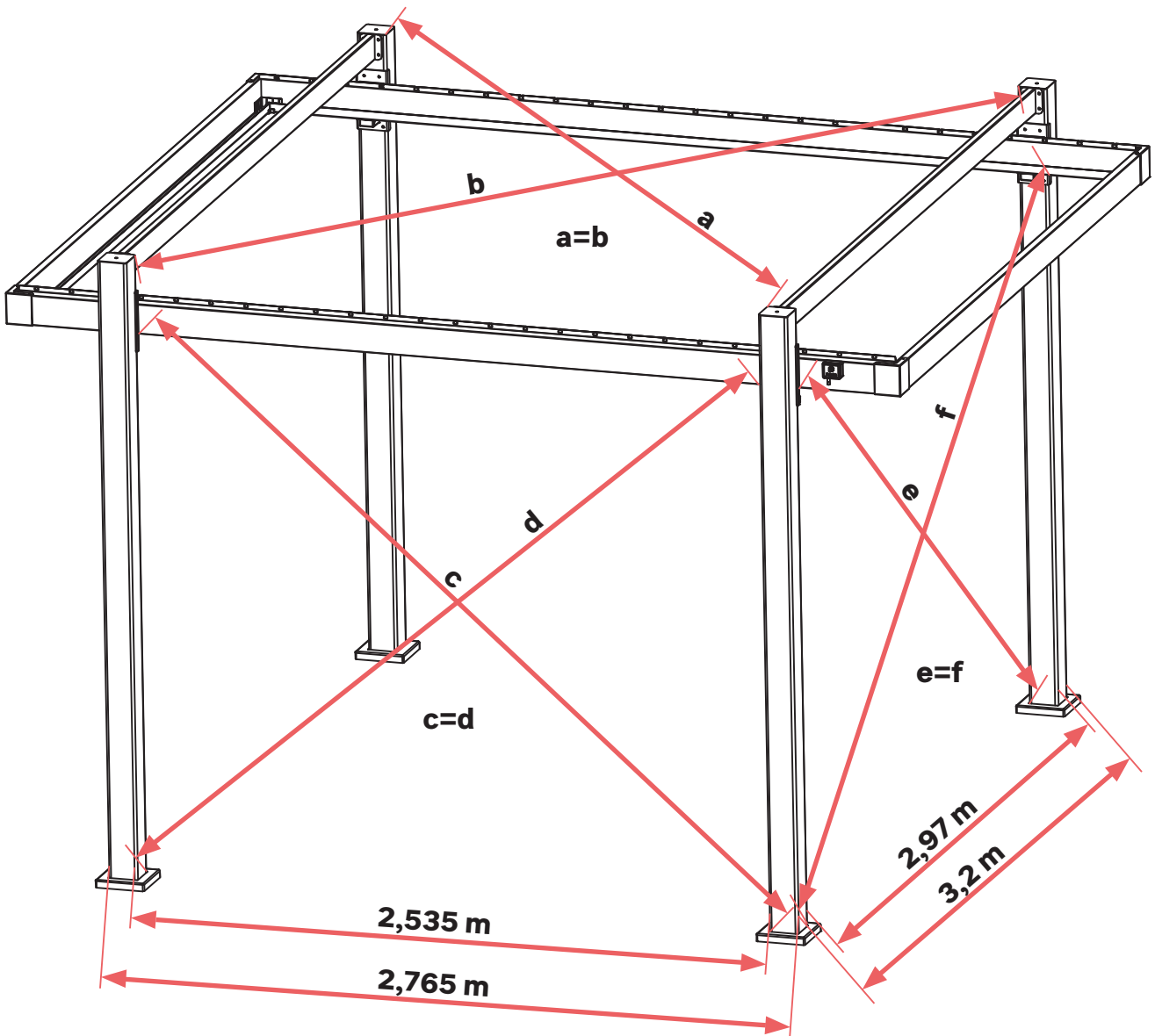
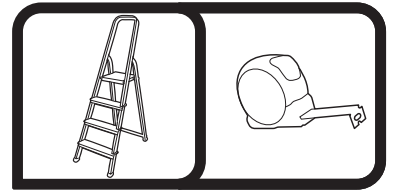



# 9

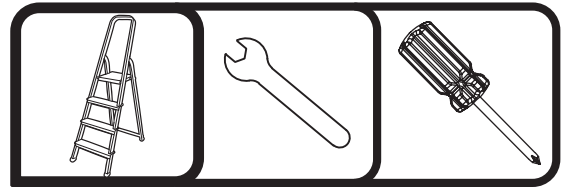

**L** x4

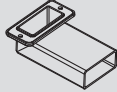

**CC** x8



**EE** x8



## 1

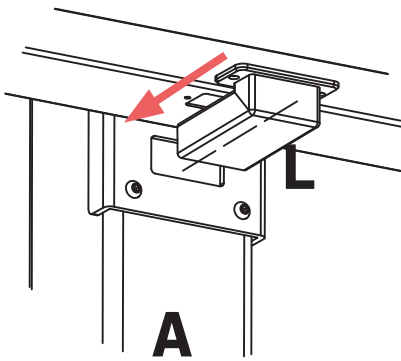

## 2

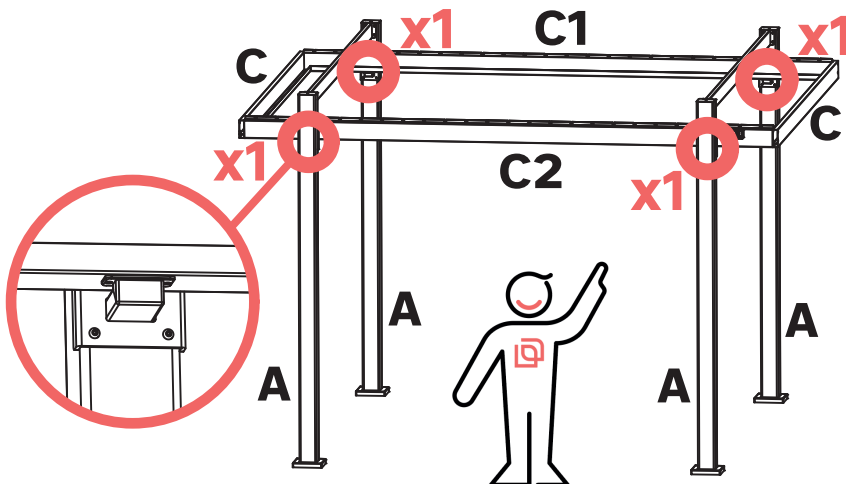
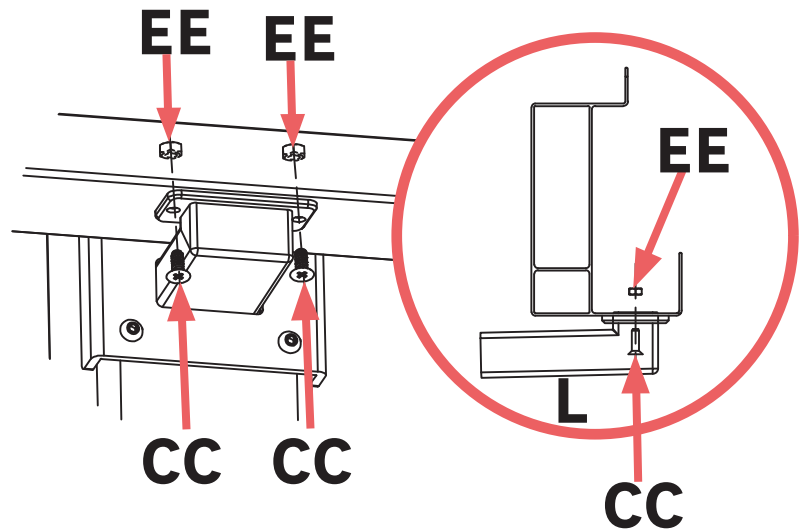



# 10

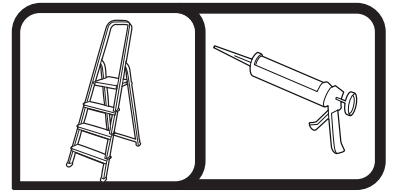

N x4

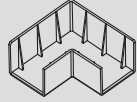

## 1

## 2

## 3

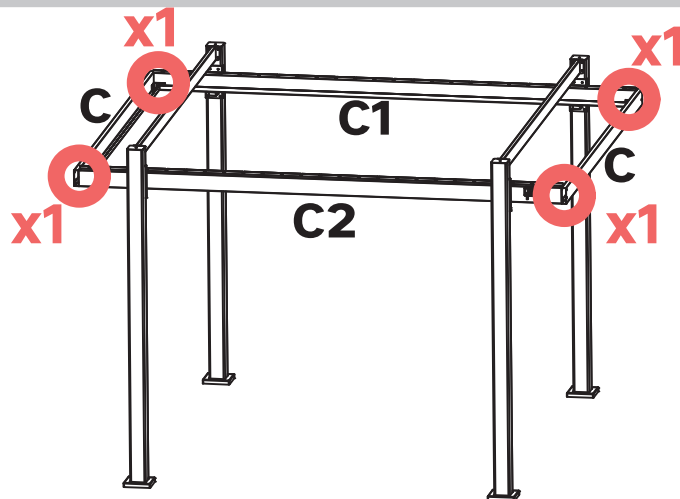
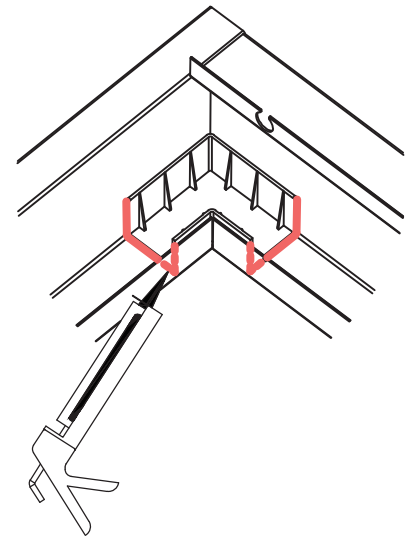
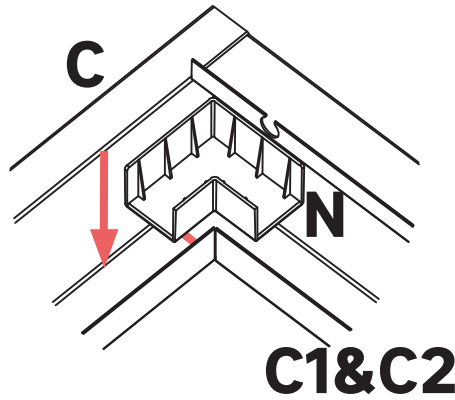
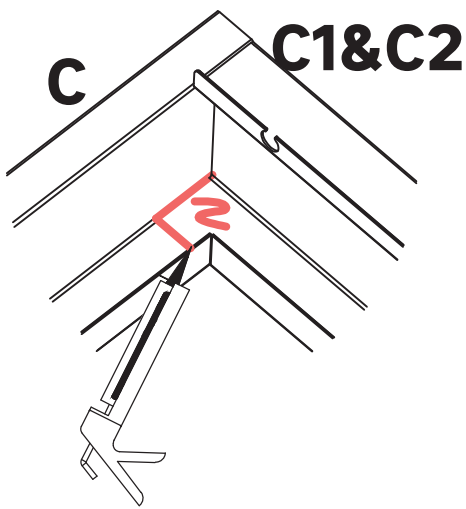



# 11

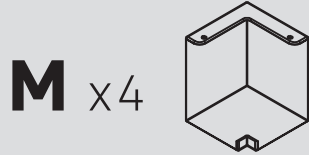
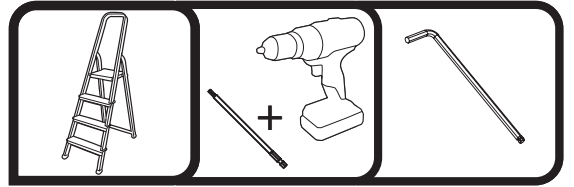

**1**

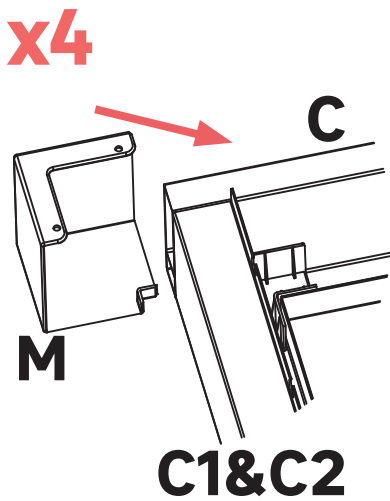

**2**

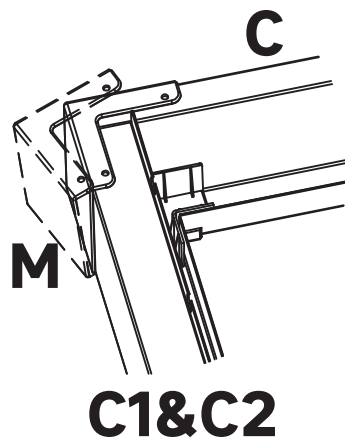

**3**

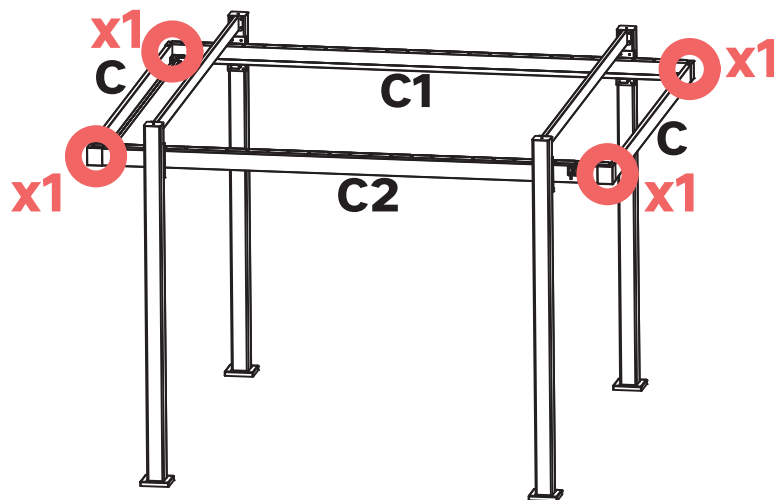
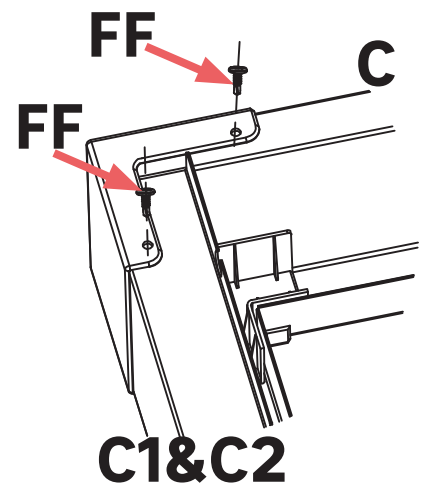



# 12

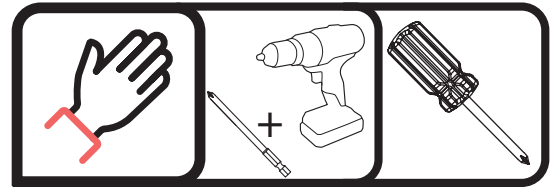

**D** x25

**GG** x50 



**J1** x25



**J2** x25

**1**

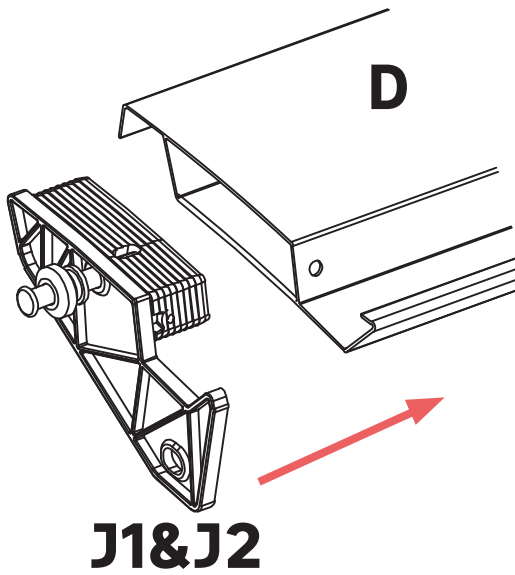

**J1&J2**

**2**

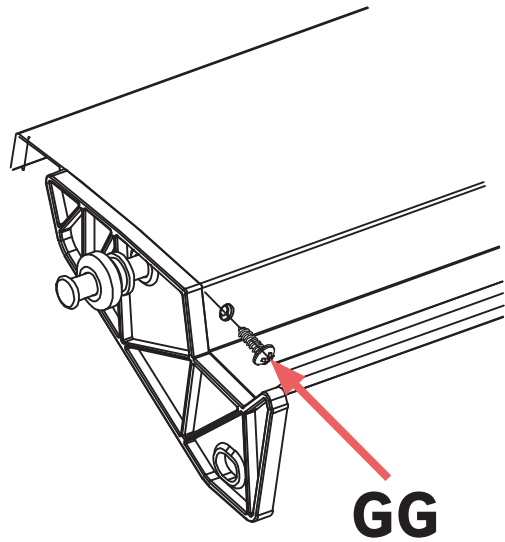

**GG**

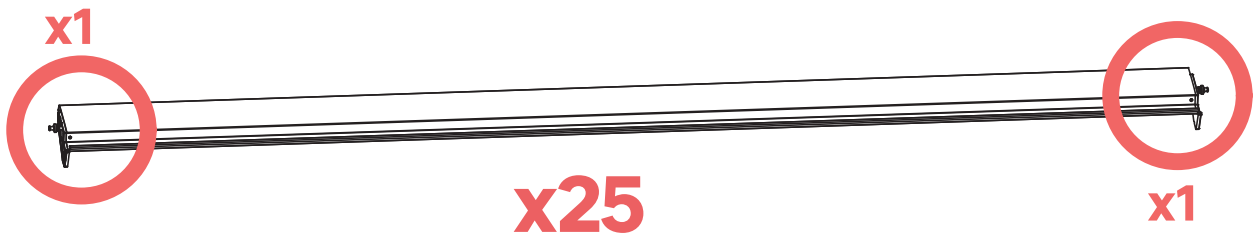

**x1**

**x25**

**x1**



# 13

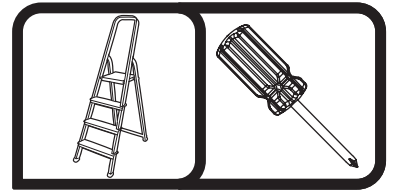

H x1

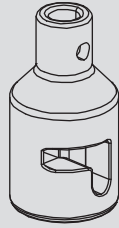

HH x1

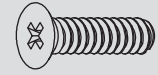

1

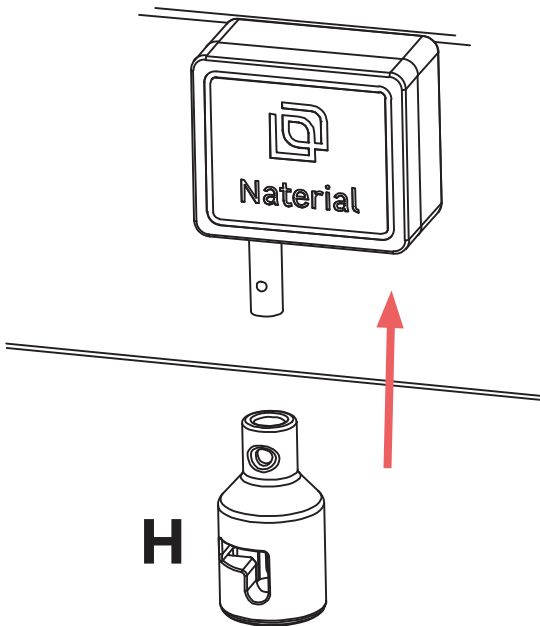

2

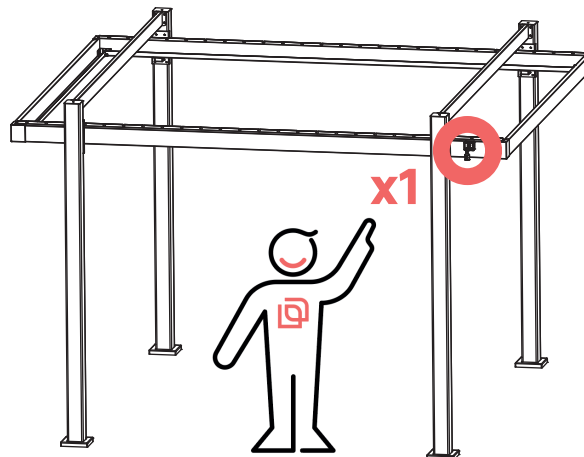
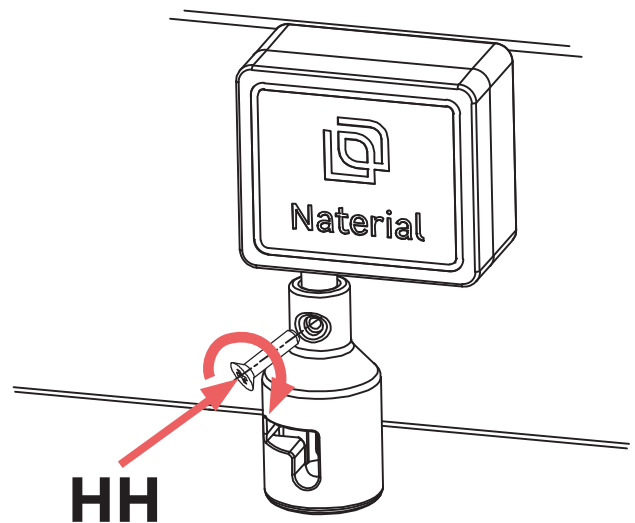



# 14

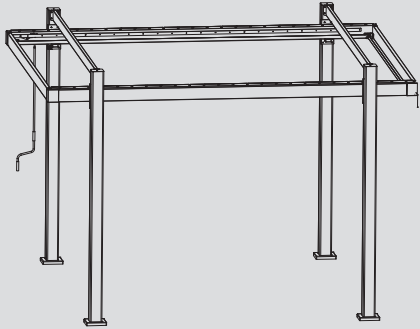
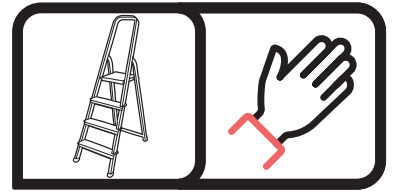

+



x2

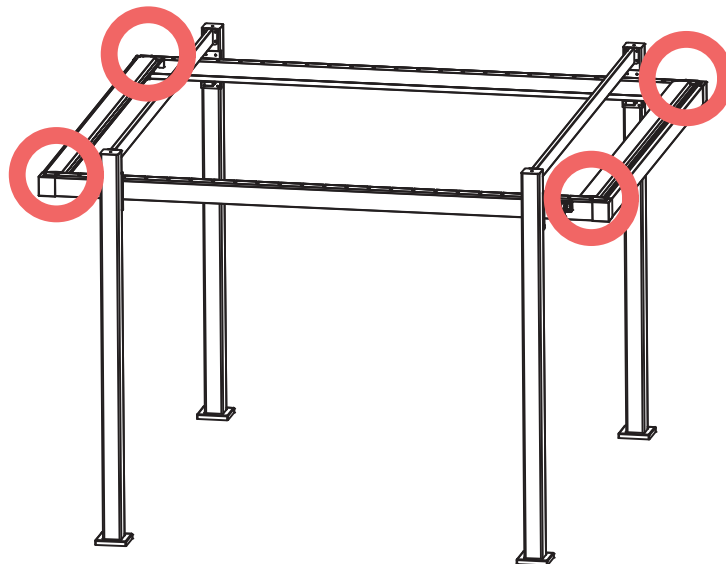
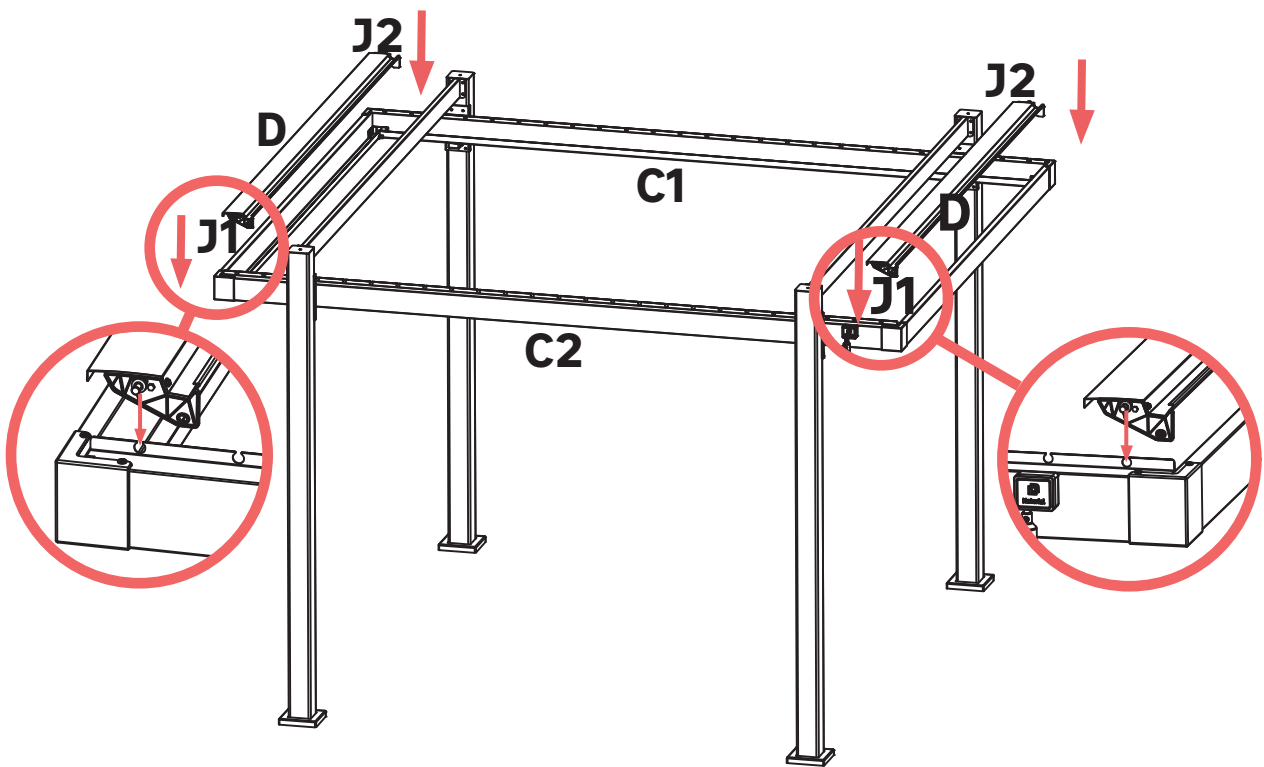



# 15

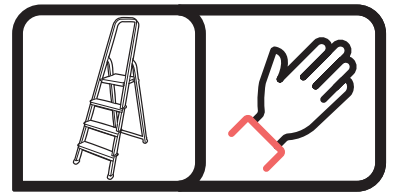

Q x4 

1

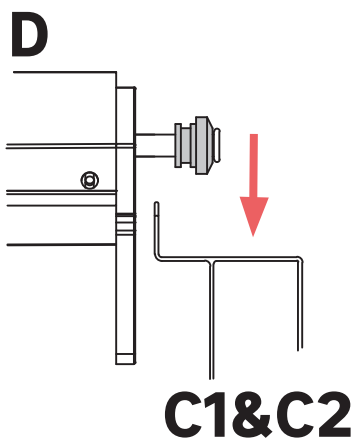

2

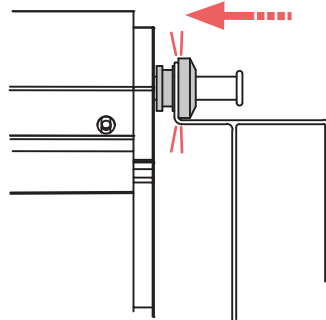

3

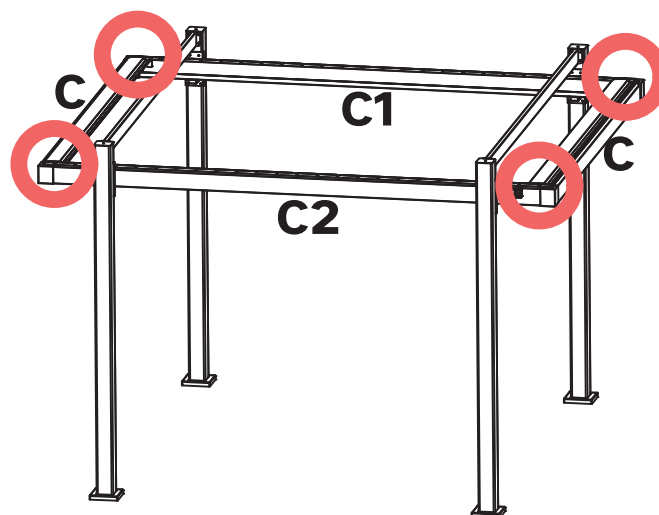
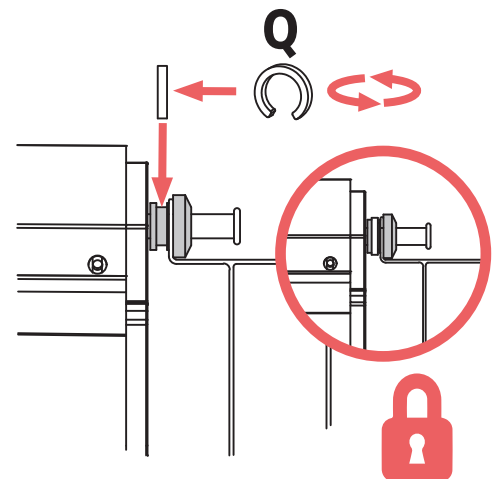



# 16

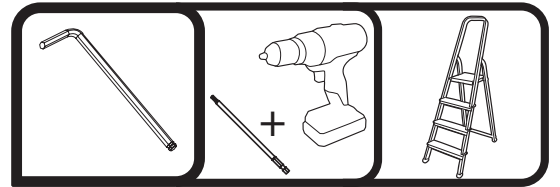

**DD** x2

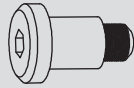

**1**

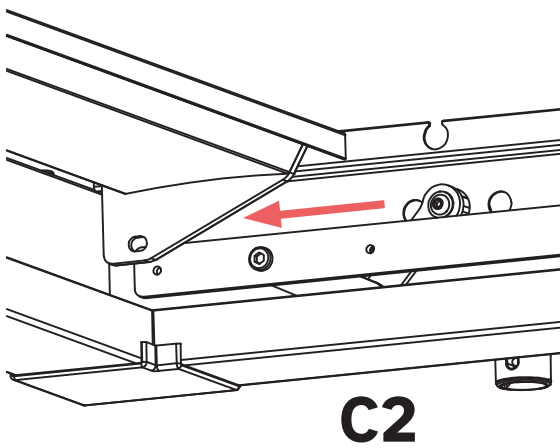

**2**

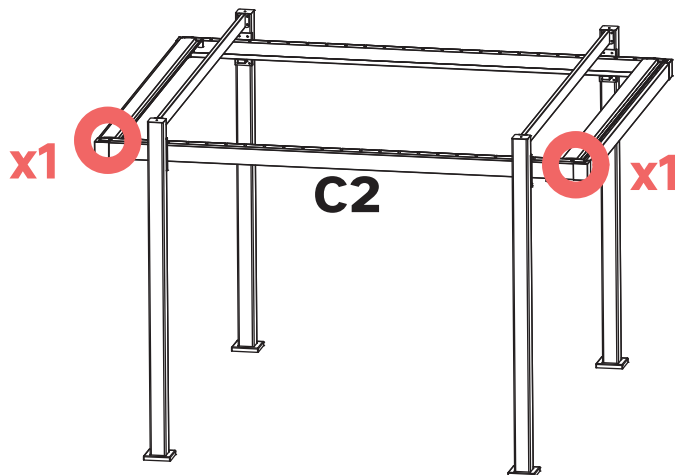
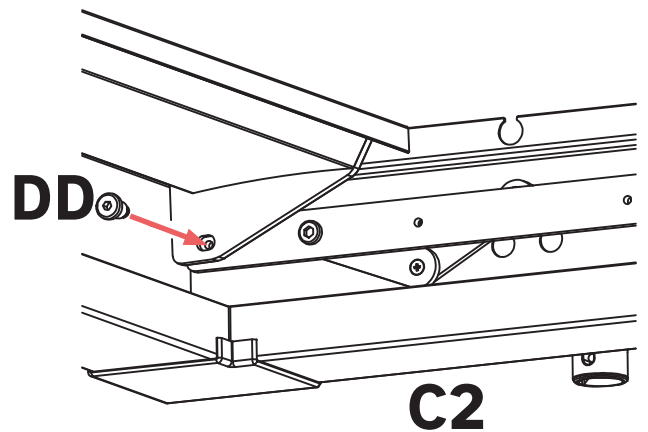



# 17



E x1

## 1

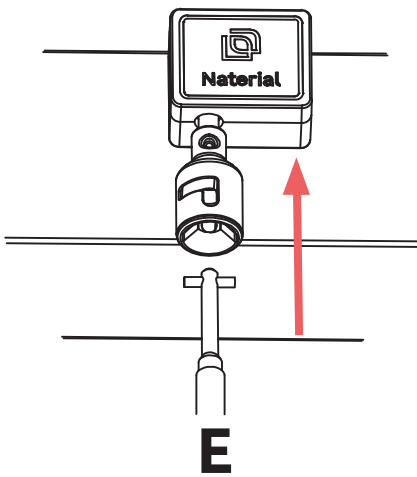

## 2

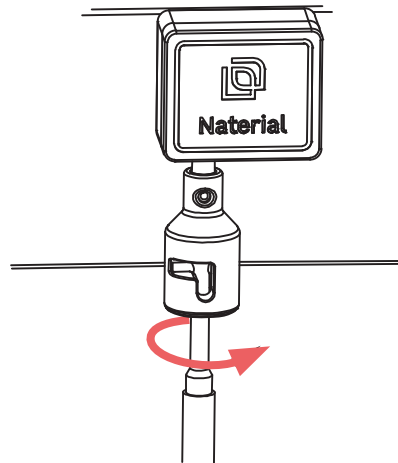

## 3

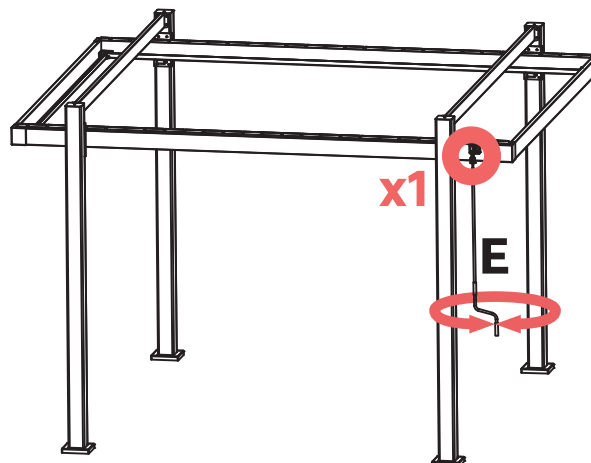
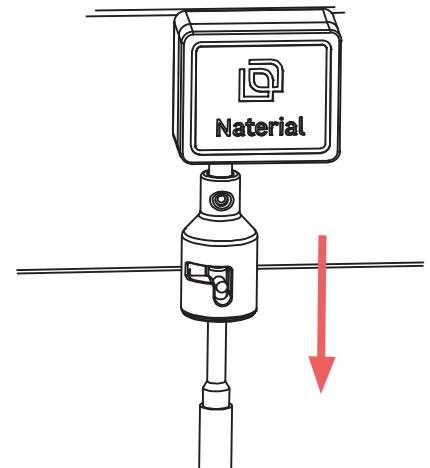



# 18

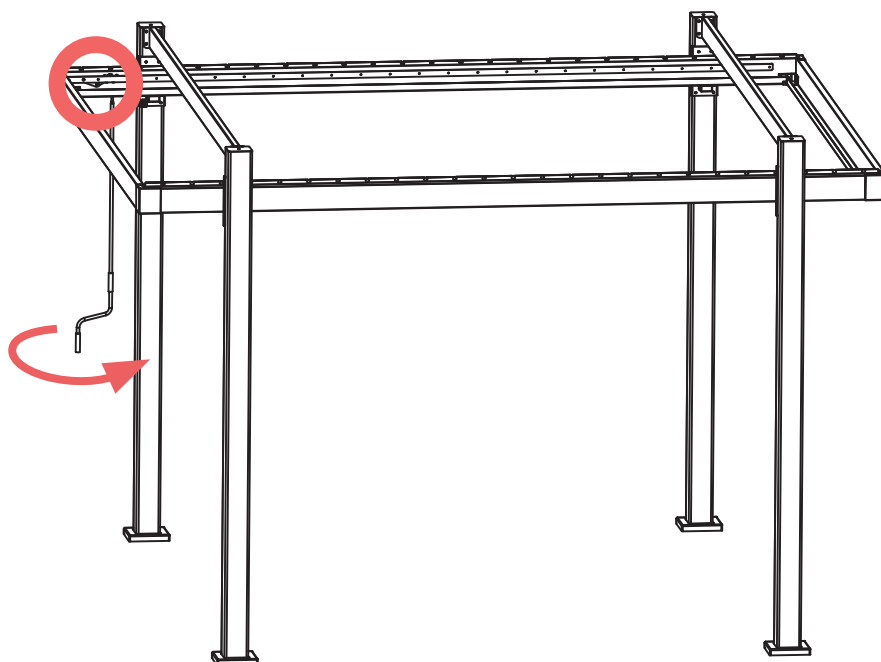
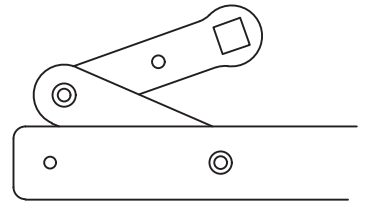
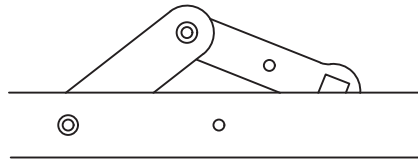
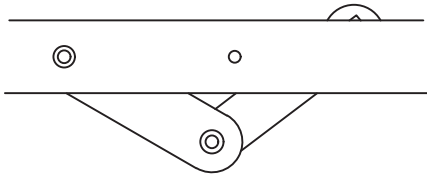



# 19



1

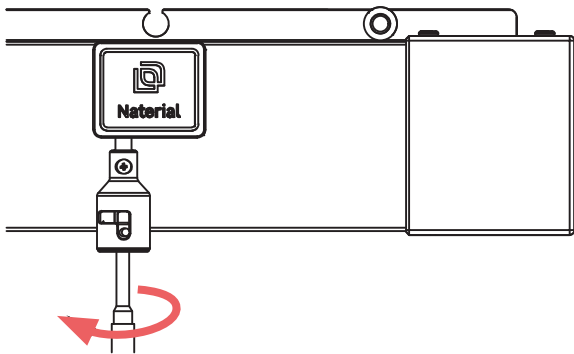

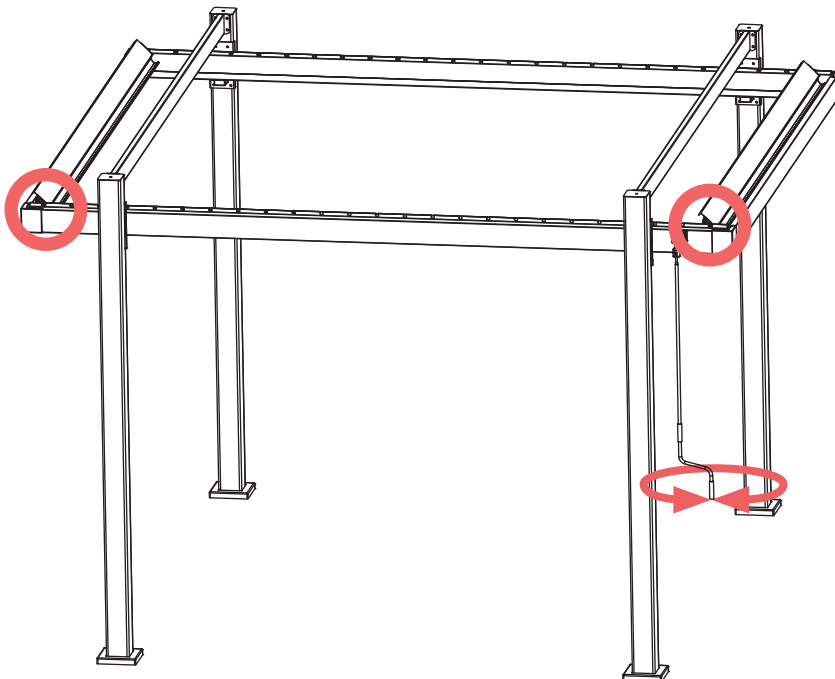
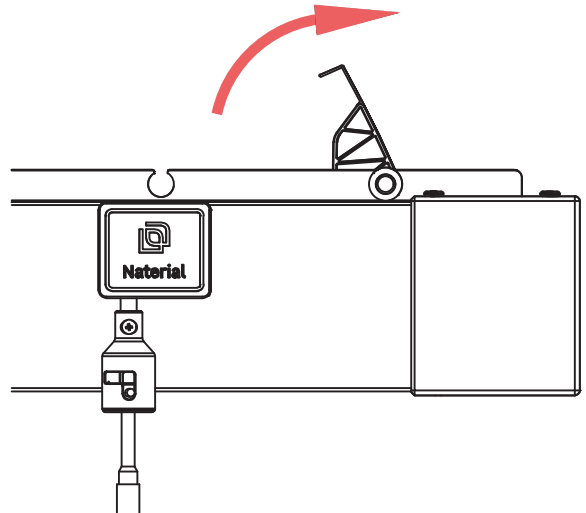

2



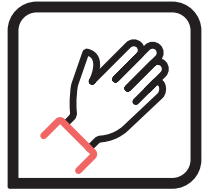
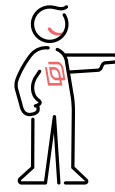

# 20



**Q** x46 



## 1

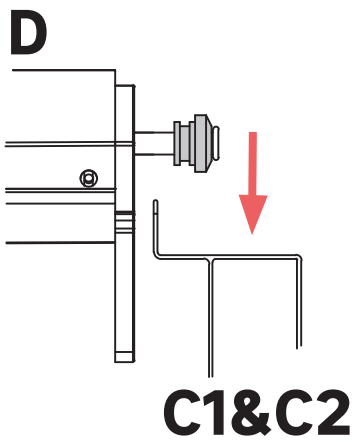

## 2

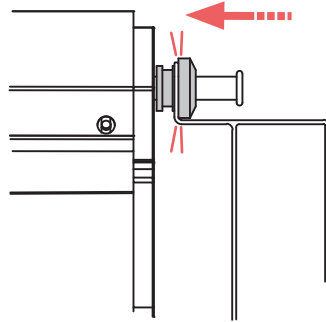

## 3

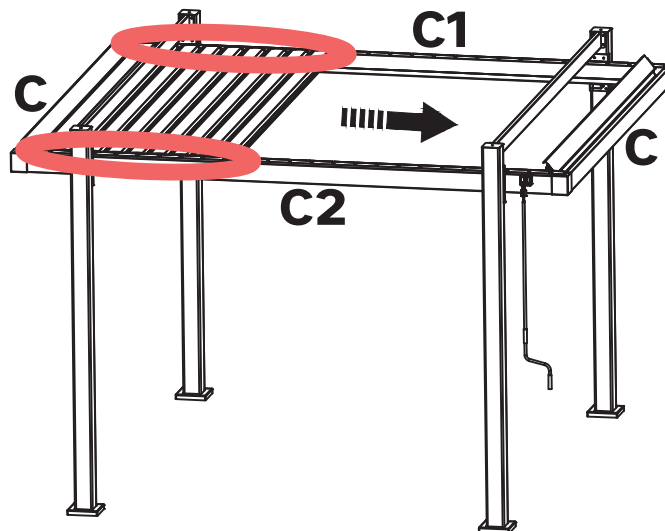
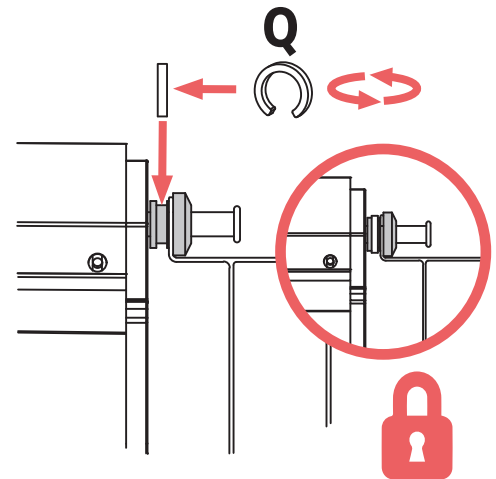



# 21

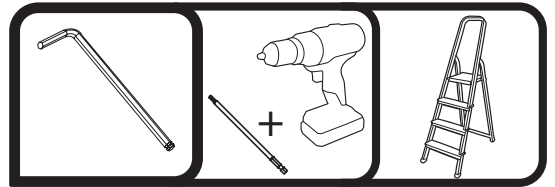

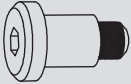
**DD** x23 

**1**

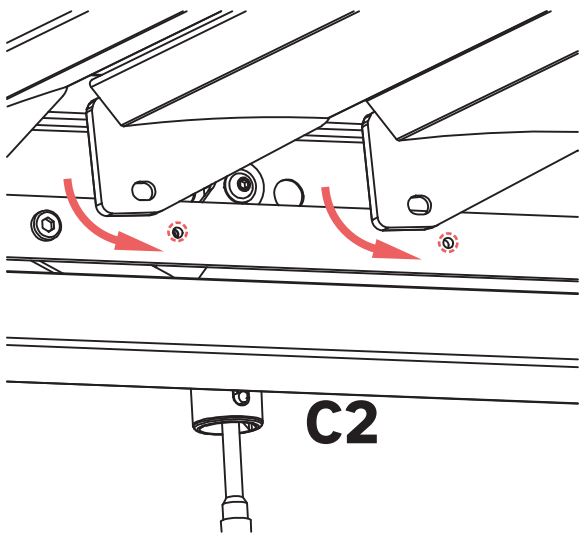

**2**

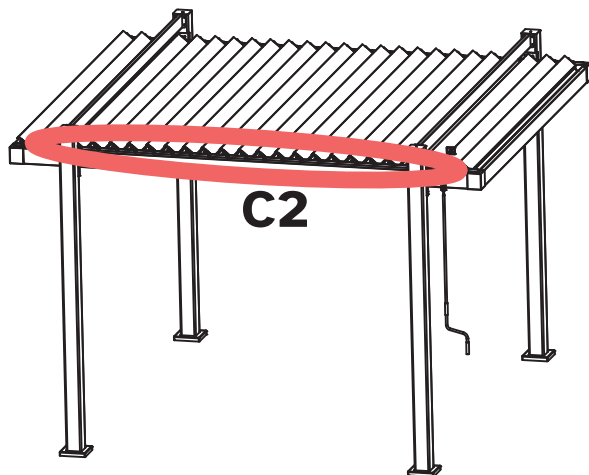
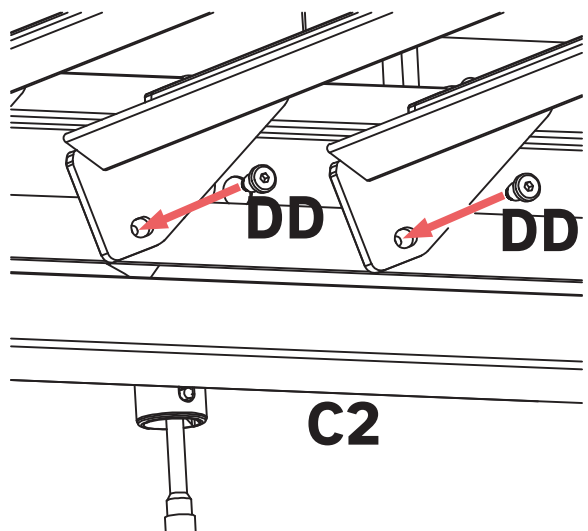



# 22

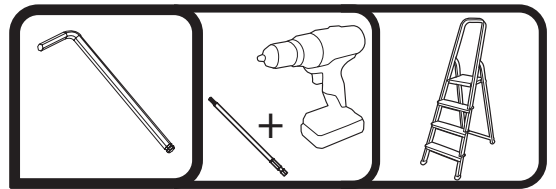

**R** x1



**1**

**2**

**3**

**4**

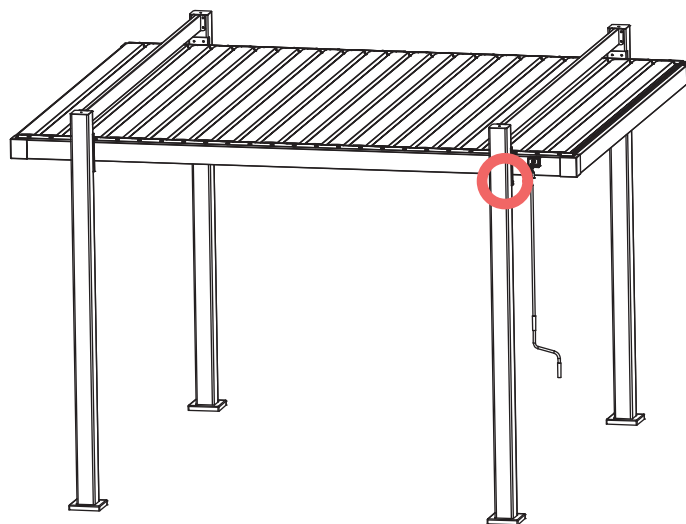
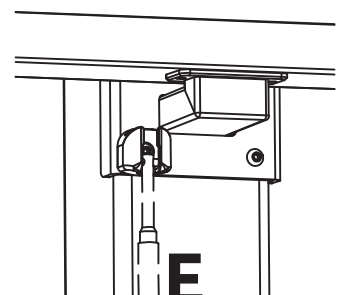
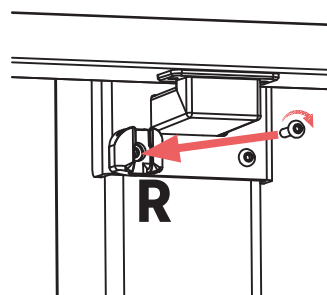
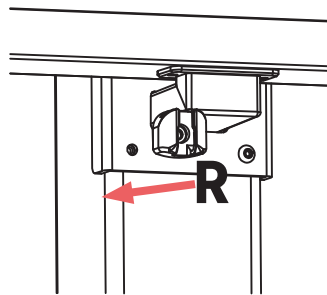
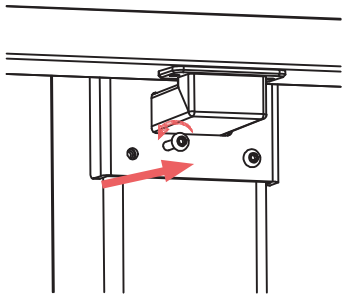



# 23

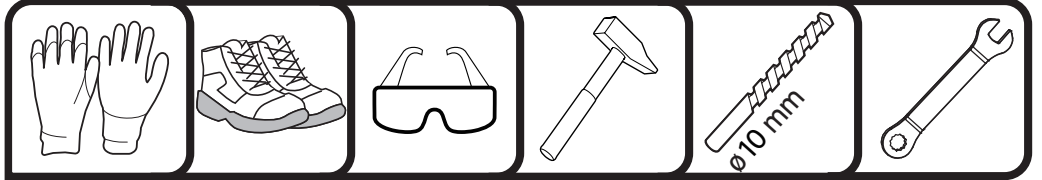

**JJ** x8

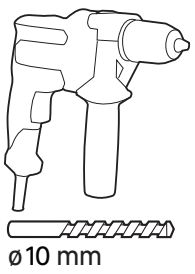

**1**

**2**

**3**

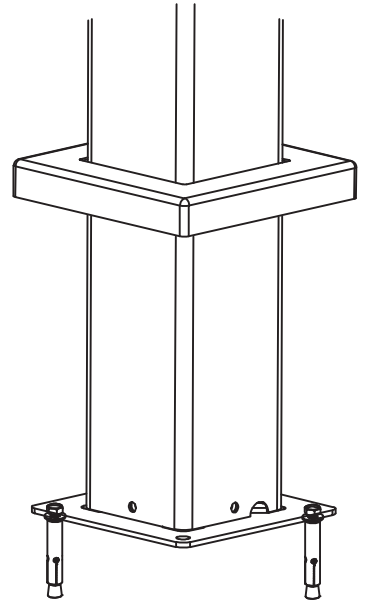
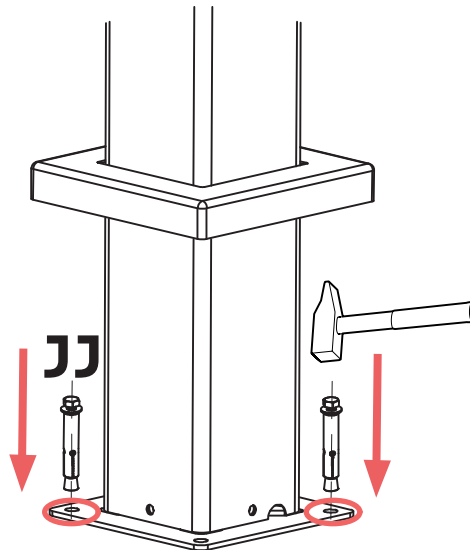
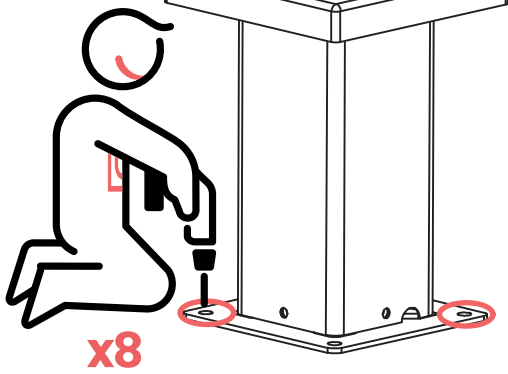

**1**

**2**

**3**

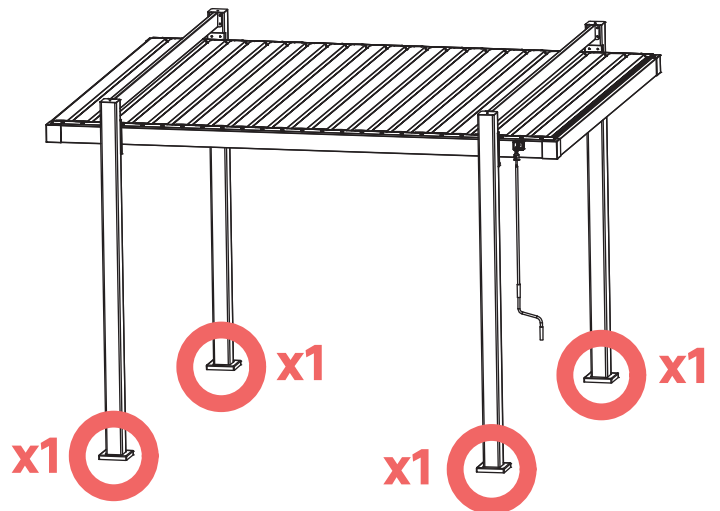
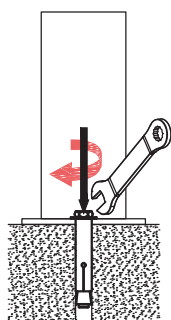
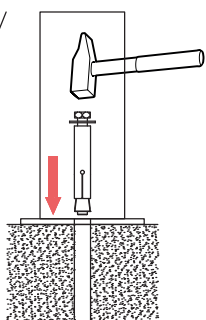
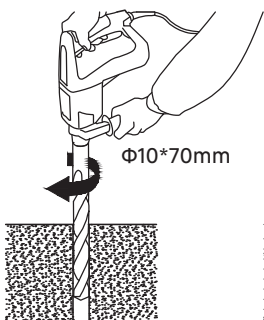



# 1

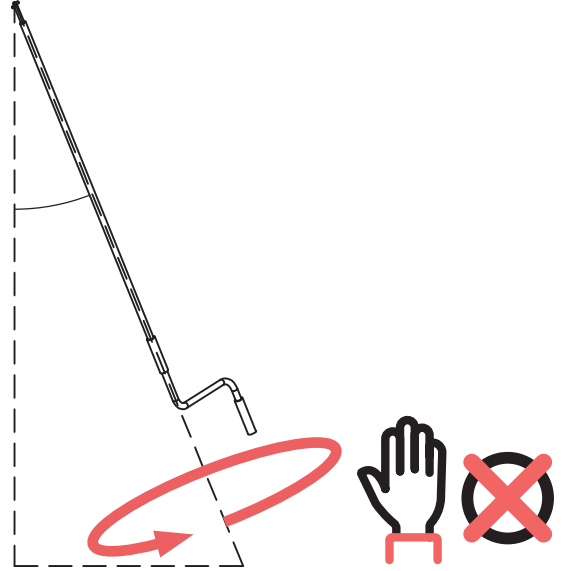
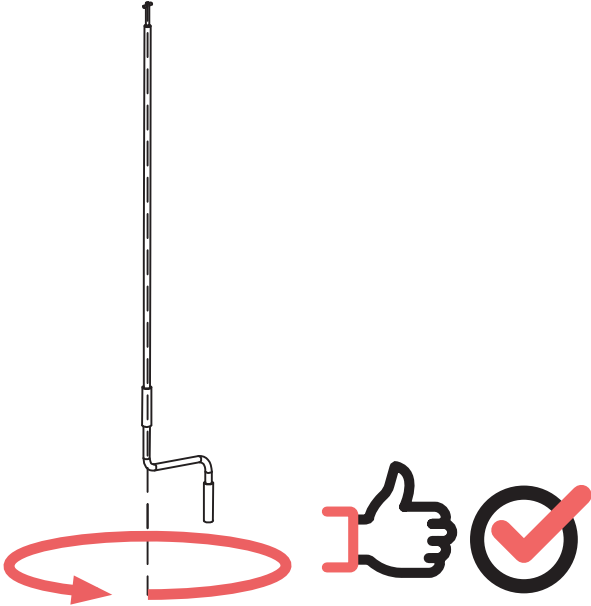
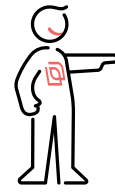

# 2

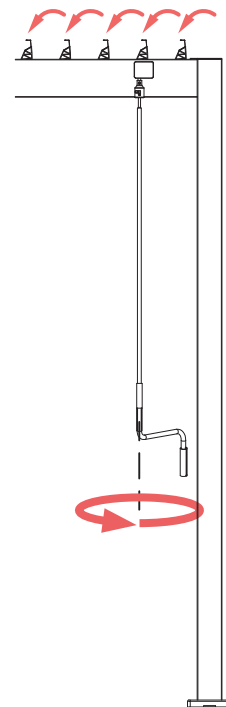
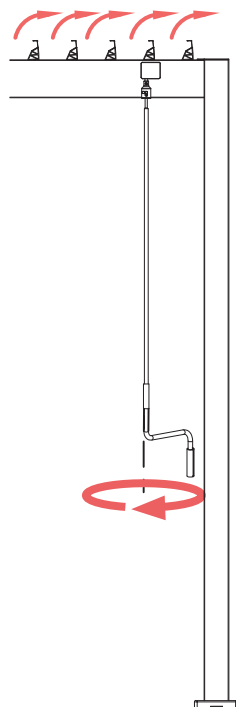



3

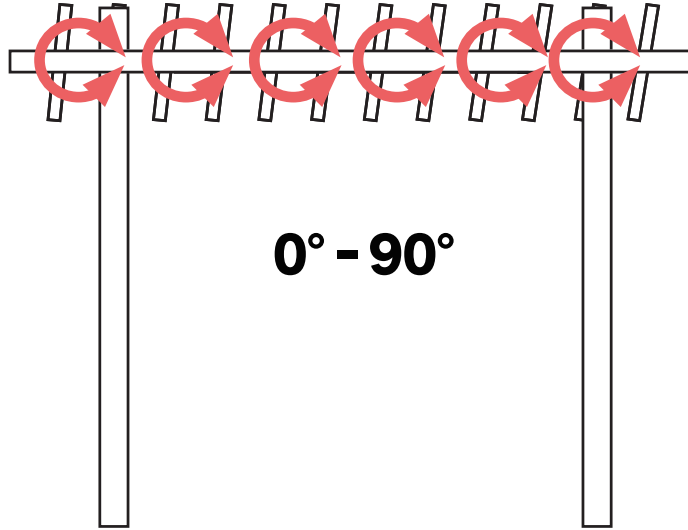
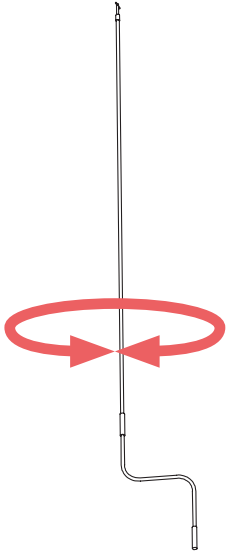
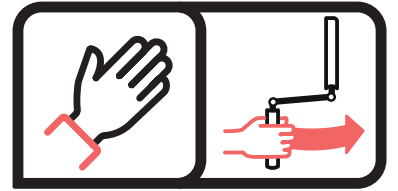

4

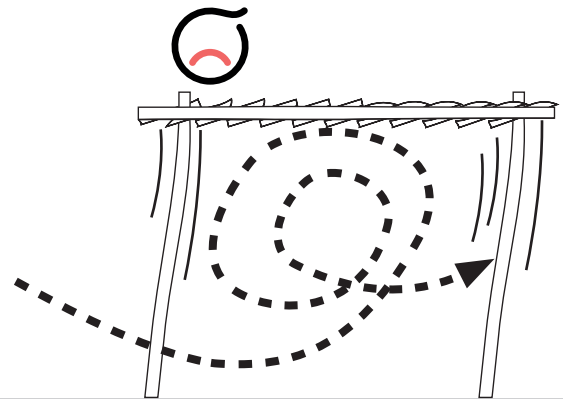
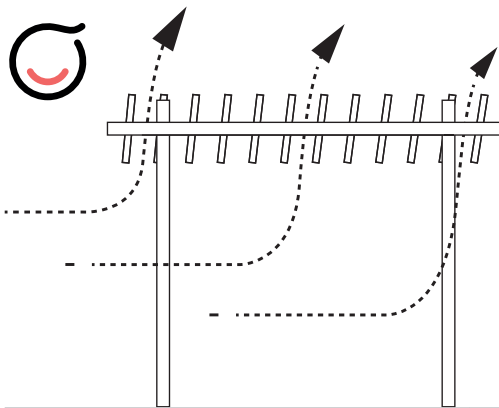
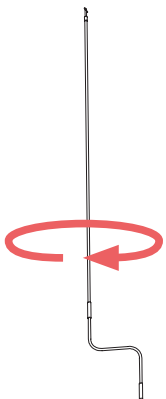
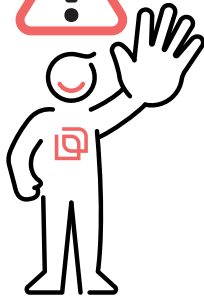
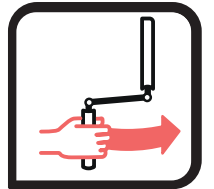



5

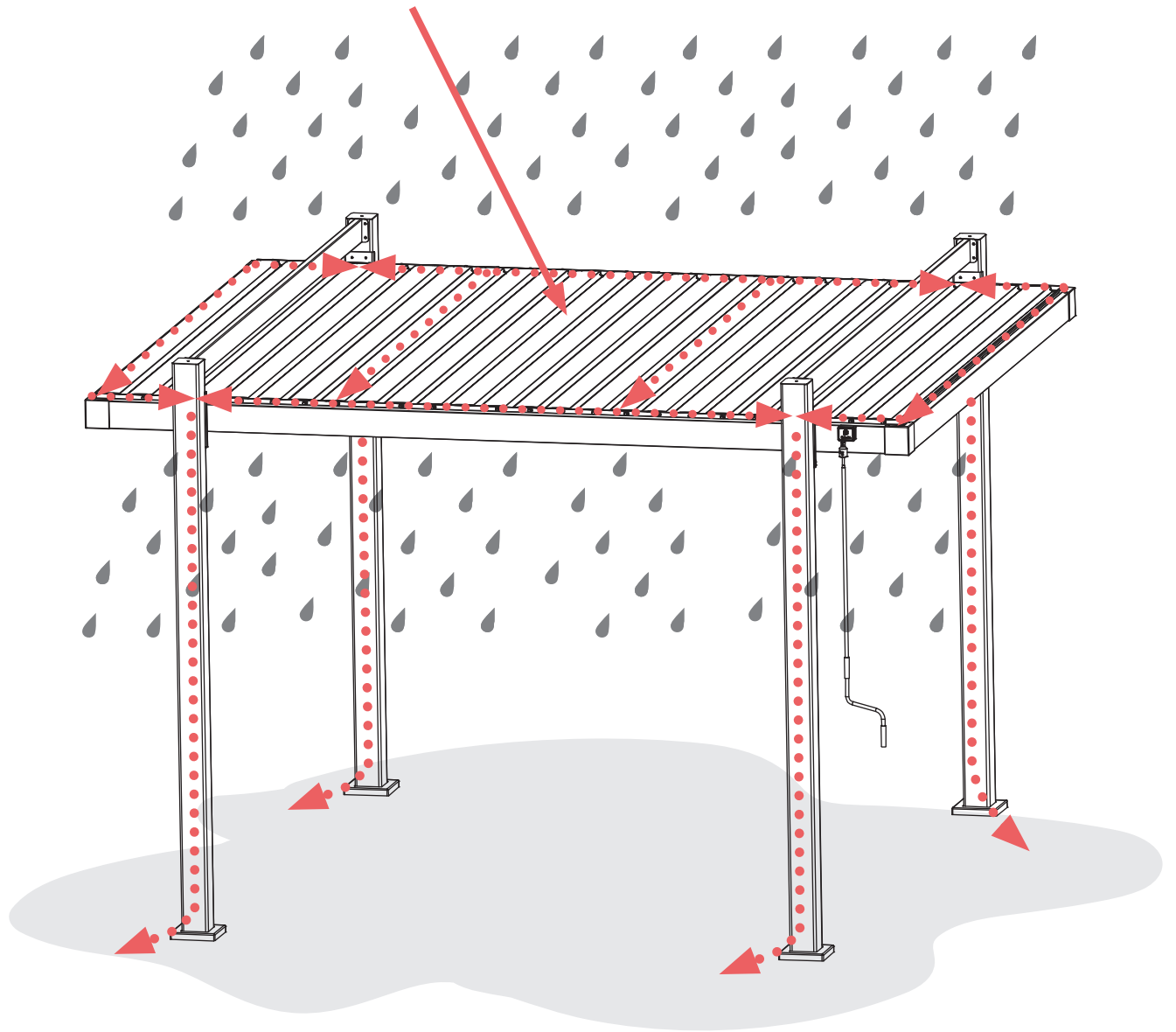
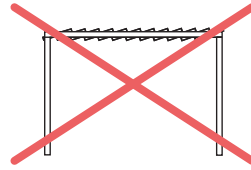
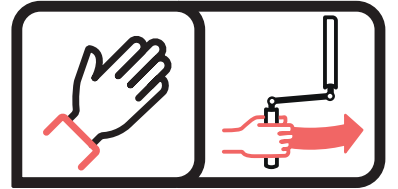

- FR** Ce produit est recyclable. S'il ne peut plus être utilisé, veuillez l'apporter dans un centre de recyclage de déchets.
- ES** Este producto es reciclable. Si ya no se puede usar, llévalo a un centro de reciclaje de residuos.
- PT** Este produto é reciclável. Se deixar de o utilizar, entregue-o num centro de reciclagem de resíduos.
- IT** Questo prodotto può essere riciclato. Se deve essere smaltito, portalo presso un centro di riciclaggio.
- EL** Αυτό το προϊόν είναι ανακυκλώσιμο. Εάν δεν μπορεί πλέον να χρησιμοποιηθεί, μεταφέρετε την σε κάποιο κέντρο ανακύκλωσης απορριμμάτων.
- PL** Ten produkt poddawany jest recyklingowi, kiedy przestaje być użyteczny należy dostarczyć go do punktu zbiórki odpadów.
- UA** Цей продукт може перероблятися. Якщо воно більше не є придатне для використання, здайте його в утилізаційний центр.
- RO** Aceast produs este reciclabil. Dacă nu mai poate fi folosit, vă rugăm să îl aduceți într-un centru de reciclare a deșeurilor.
- BR** Este produto é reciclável. Se não puder mais ser usado, descarte em um centro de reciclagem de resíduos.
- EN** This product is recyclable. If it cannot be used anymore, please take it to waste recycling centre.



Production date :  
MM / YYYY



\*\* Garantie 5 ans / 5 años de garantía / Garantia de 5 anos / Garanzia 5 anni / Εγγύηση 5 ετών / Gwarancja 5-letnia / Гарантія 5 років / Garantie 5 ani /  
Garantia 5 anos / 5-year warranty

EU : ADEO SERVICES  
135, rue Sadi Carnot- CS 00001 59790- RONCHIN- France  
[www.product-regulatory.adeoservices.com](http://www.product-regulatory.adeoservices.com)

UA : Виробник: ТОВ "Адео Сервісез С.А.", вул. Саді Карно, CS 00001, 59790 Роншен, Франція. Імпортер: ТОВ "Леруа Мерлен Україна", 04201 Україна, м.Київ, вул. Полярна 17А, +380 44 498 46 00. Імпортер приймає претензії від споживачів щодо товару, а також проводить його ремонт, технічне і гарантійне обслуговування.

BR : LEROY MERLIN COMPANHIA BRASILEIRA DE BRICOLAGEM CNPJ: 01.438.784/0001-05  
Rua Pascoal Pais, nº. 525, 6º andar cj 61 a 64, Vila Cordeiro, São Paulo -SP. CEP: 04581-060  
CALM (Central de Atendimento Leroy Merlin) Capitais 4020-5376 Demais Regiões 0800-0205376  
IMAGENS ILUSTRATIVAS

SA : Imported by Adeo South Africa (PTY) LTD T/A Leroy Merlin  
Hosted in Leroy Merlin Fourways Store, 35 Roos Street, Witkoppen Ext 97, Sandton, 2191  
Johannesburg, Gauteng, South Africa

Tel : +27 10 493 8000

Email : [contact@leroymerlin.co.za](mailto:contact@leroymerlin.co.za)

**Made in China**  
Країна походження Китай / Fabricado na China