

DEXTER PRO

5
YEAR
Guarantee*

**VACUUM CLEANER WET
& DRY + PLASTER 30L**
1500DWDP-30.5001

FR ASPIRATEUR EAU ET POUSSIÈRE + PLÂTRE - 30 L- DWDP 30

ES ASPIRADOR PARA SECO Y MOJADO + YESO 30 L- DWDP 30

PT ASPIRADOR DE PÓ E DE LÍQUIDOS + GESSO 30L-DWDP 30

IT BIDONE ASPIRA SOLIDI/LIQUIDI + ASPIRATORE DA CANTIERE 30L-DWDP 30

EL ΗΛΕΚΤΡΙΚΗ ΣΚΟΥΠΙΑ ΥΓΡΩΝ ΚΑΙ ΣΤΕΡΕΩΝ + ΣΚΟΝΗΣ ΓΥΨΟΥ 30L-DWDP 30

PL ODKURZACZ DO CZYSZCZENIA NA MOKRO I SUCHO + PLASTER 30L-DWDP 30

UA ПИЛОСОС ДЛЯ СУХОГО Й ВОЛОГОГО ПРИБИРАННЯ ТА ПРИБИРАННЯ БУДІВЕЛЬНОГО ПИЛУ 30 Л — DWDP 30

RO ASPIRATOR ÎN SISTEM UMED ȘI USCAT + PRAF DE GIPS - 30 L-DWDP 30

EN VACUUM CLEANER WET & DRY + PLASTER 30L-DWDP 30

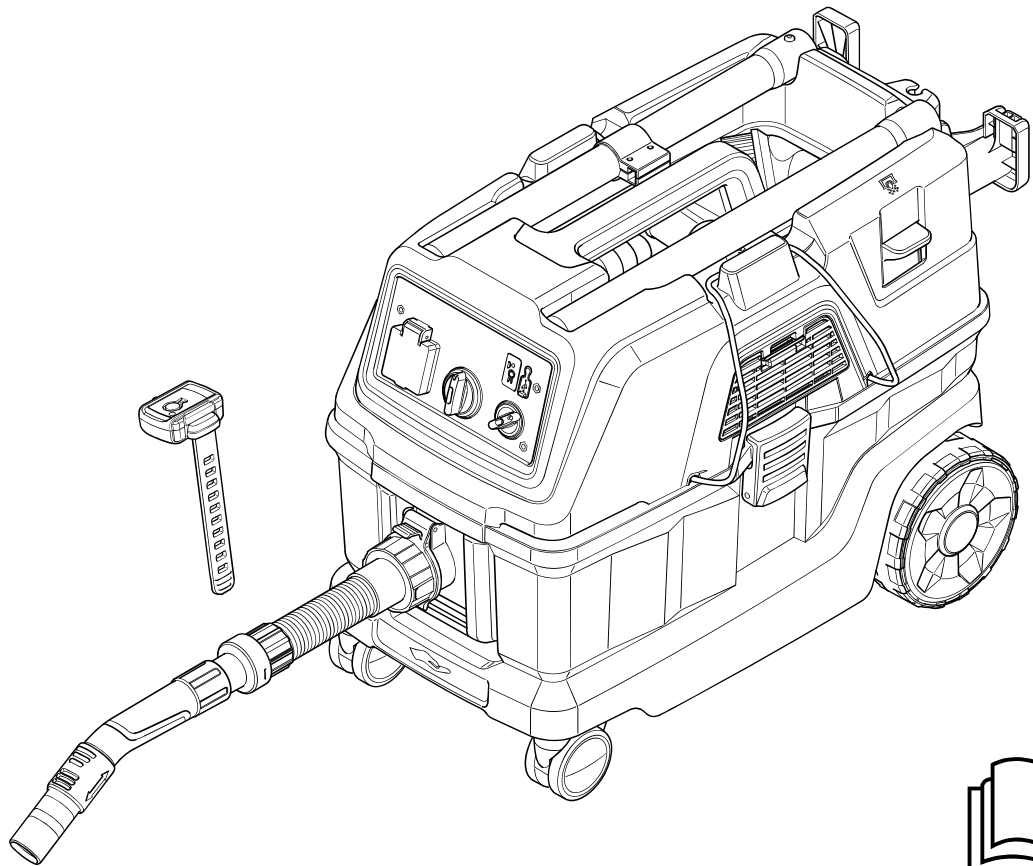
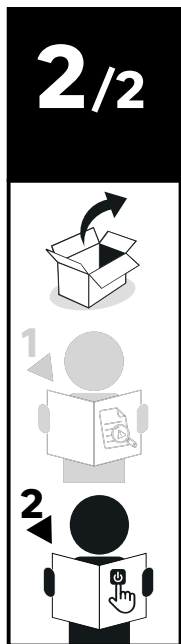

2025/09-V01



EAN CODE : 3276007976625

FR Manuel d'Instructions

ES Manual de Instrucciones

PT Manual de Instruções

IT Manuale di Istruzioni

EL Εγχειρίδιο Οδηγών

PL Instrukcja Obsługi

UA Інструкція з Експлуатації

RO Manual de Instrucțiuni

EN Instructions Manual

FR. Traduction de la version originale du mode d'emploi / ES. Traducción de la versión original del manual de instrucciones / PT. Tradução da versão original do manual de instruções / IT. Traduzione della versione originale del manuale d'uso / EL. Μετάφραση της αρχικής έκδοσης των οδηγιών χρήσης / PL. Tłumaczenie oryginalnej wersji instrukcji obsługi / UA. Переклад оригінальної версії інструкції з експлуатації / RO. Traducerea versiunii originale a manualului de utilizare / EN. Translation of the original instructions manual



**FR**

Nous vous remercions d'avoir acheté ce produit. Nous vous conseillons de lire attentivement la notice d'installation, d'utilisation et d'entretien. Nous avons conçu ce produit pour vous apporter entière satisfaction. Si vous avez besoin d'aide, l'équipe de votre magasin est à votre disposition pour vous accompagner.

ES

Le agradecemos haber comprado este producto. Le recomendamos leer atentamente el manual de instalación, uso y mantenimiento. Este producto ha sido diseñado para proporcionarle plena satisfacción. Si necesita alguna ayuda, el personal de la tienda estará a su disposición para guiarle.

PT

Agradecemos a sua preferência por este produto. Aconselhamo-lo a ler o manual de instalação, utilização e manutenção com atenção. Criámos este produto para sua completa satisfação. Se precisar de ajuda, a equipa da sua loja está à sua disposição para o acompanhar.

IT

Grazie per aver acquistato questo prodotto. Vi raccomandiamo di leggere attentamente il manuale di installazione, utilizzo e manutenzione. Questo prodotto è stato progettato per offrirvi la massima soddisfazione. Per ricevere assistenza, il personale del punto vendita è a vostra disposizione.

EL

Ευχαριστούμε για την αγορά σας αυτού του προϊόντος. Σας συμβουλεύουμε να διαβάσετε προσεκτικά τις οδηγίες εγκατάστασης, χρήσης και συντήρησης. Σχεδιάσαμε αυτό το προϊόν για να σας προσφέρει πλήρη ικανοποίηση. Αν χρειάζεστε βοήθεια, η ομάδα του καταστήματος από το οποίο αγοράσατε το προϊόν είναι στη διάθεσή σας.

PL

Dziękujemy za zakup produktu firmy. Zalecamy, aby uważnie przeczytać instrukcję instalacji, użytkowania i konserwacji. Ten produkt marki zaprojektowaliśmy, aby spełnić wszystkie Państwa oczekiwania. W razie potrzeby pracownicy sklepu służą Państwu pomocą i są do Państwa dyspozycji.

UA

Дякуємо вам за покупку цього виробу. Ми радімо вам уважно прочитати інструкцію із установлення, експлуатації та технічного обслуговування. Ми розробили цей виріб для того, щоб він приносив вам задоволення. Якщо вам потрібна допомога, співробітники вашого магазину готові допомогти вам.

RO

Vă mulțumim pentru achiziționarea acestui produs. Vă sfătuim să citiți cu atenție instrucțiunile de instalare, de utilizare și de întreținere. Am conceput acest produs pentru a vă furniza satisfacție totală.

Dacă aveți nevoie de ajutor, echipa magazinului de cumpărare este la dispoziția dumneavoastră și vă va asista.

EN

Thank you for purchasing this product. We recommend that you read the installation, user and maintenance instructions carefully. We have designed this product to ensure your complete satisfaction. If you require assistance, the team at your retailer is on hand to help you.

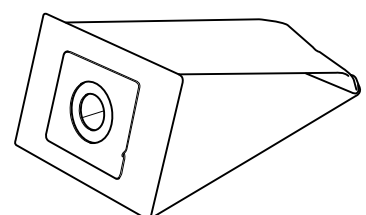
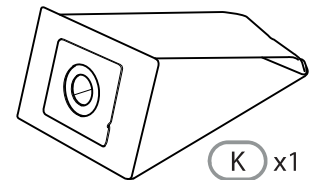
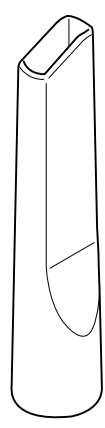
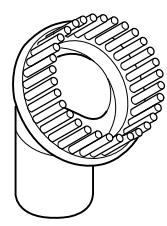
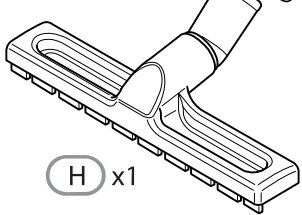
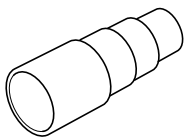
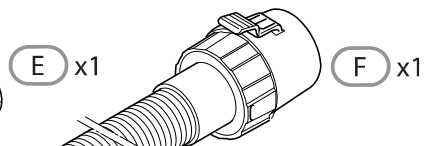
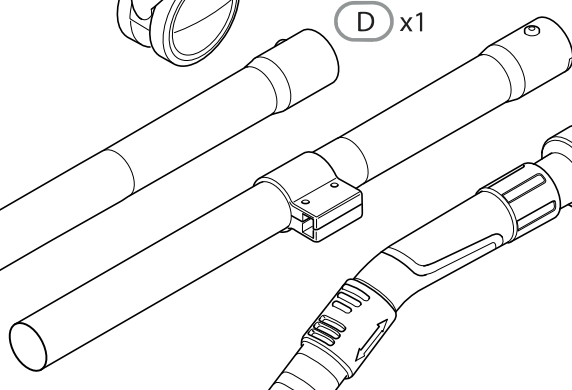
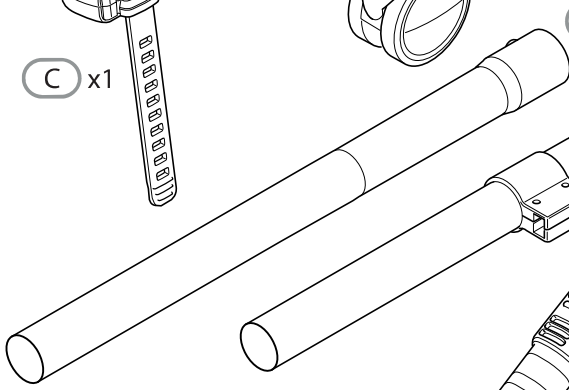
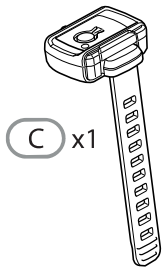
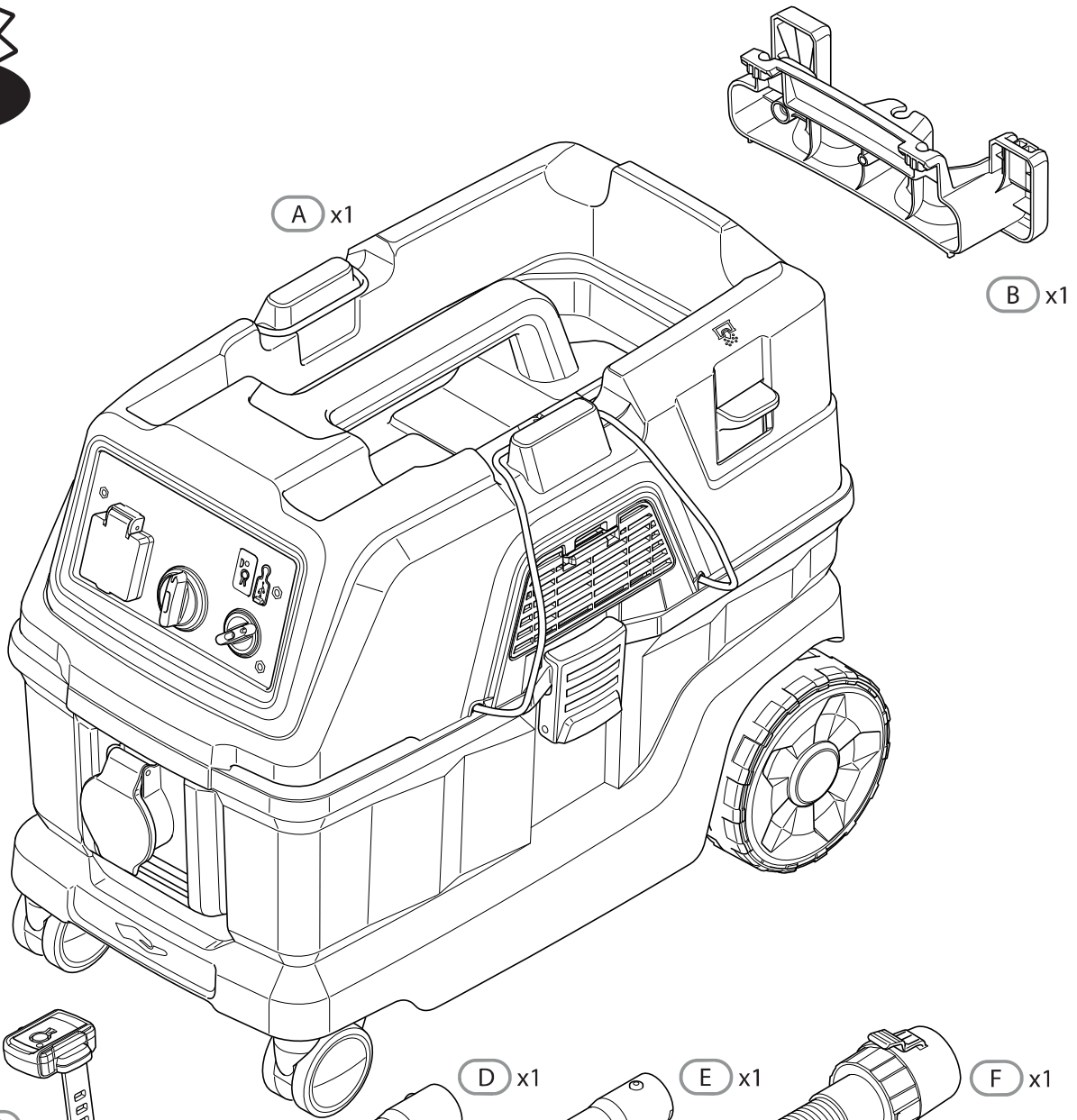



FR. Attention danger / **ES.** Atención peligro / **PT.** Atenção perigo / **IT.** Attenzione pericolo / **EL.** Προσοχή κίνδυνος /
PL. Uwaga niebezpieczeństwo / **UA.** Увага, небезпека / **RO.** Atenție pericol / **EN.** Warning danger



FR. Montage / **ES.** Montaje / **PT.** Montagem / **IT.** Montaggio / **EL.** Συναρμολόγηση / **PL.** Montaż / **UA.** Монтаж / **RO.** Montaj /
EN. Assembly



6 → 8



FR. Utilisation / **ES.** Uso / **PT.** Utilização / **IT.** Utilizzo / **EL.** Χρήση / **PL.** Użytkowanie / **UA.** Використання / **RO.** Utilizare /
EN. Use



9 → 10



1

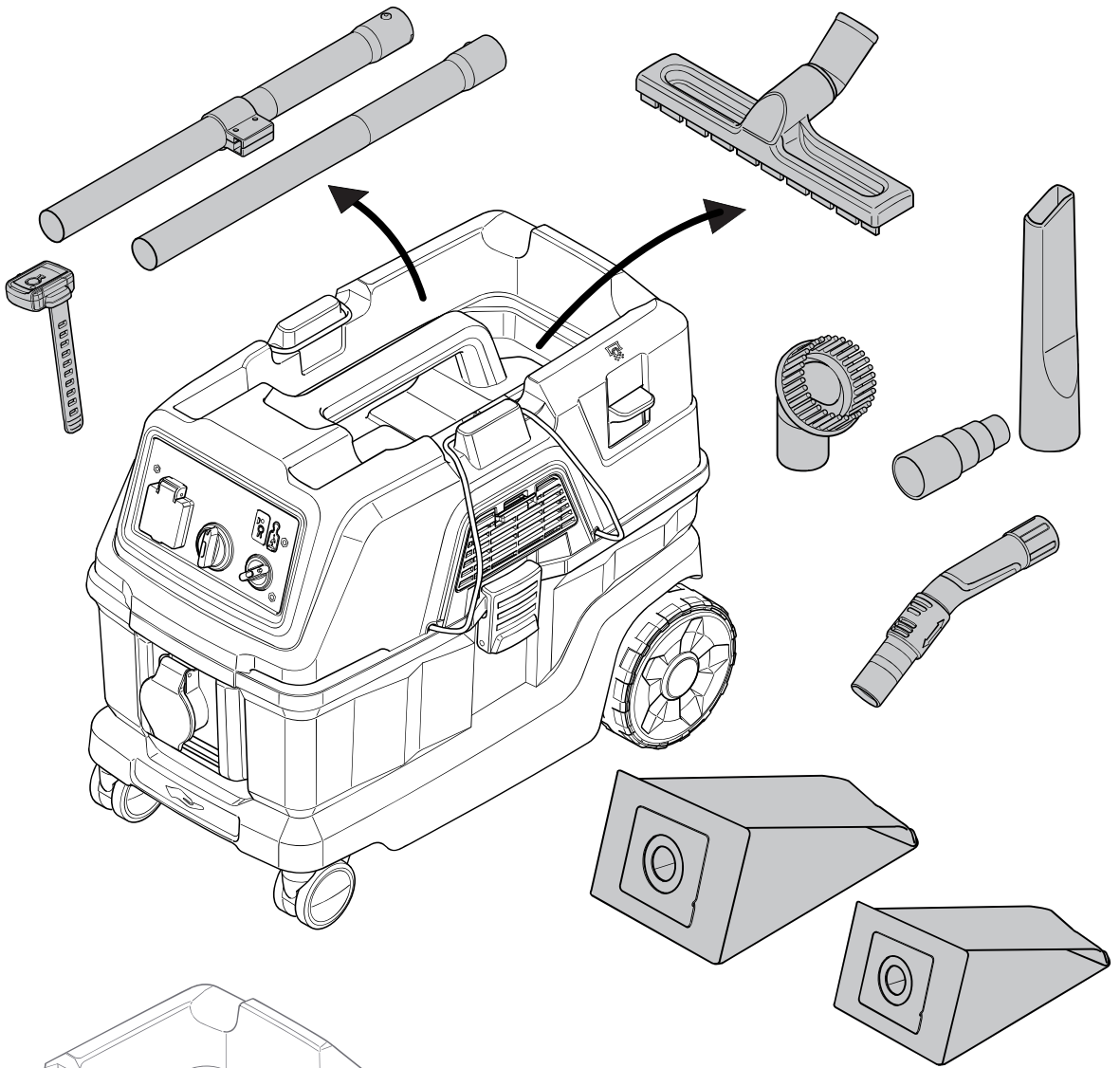

2

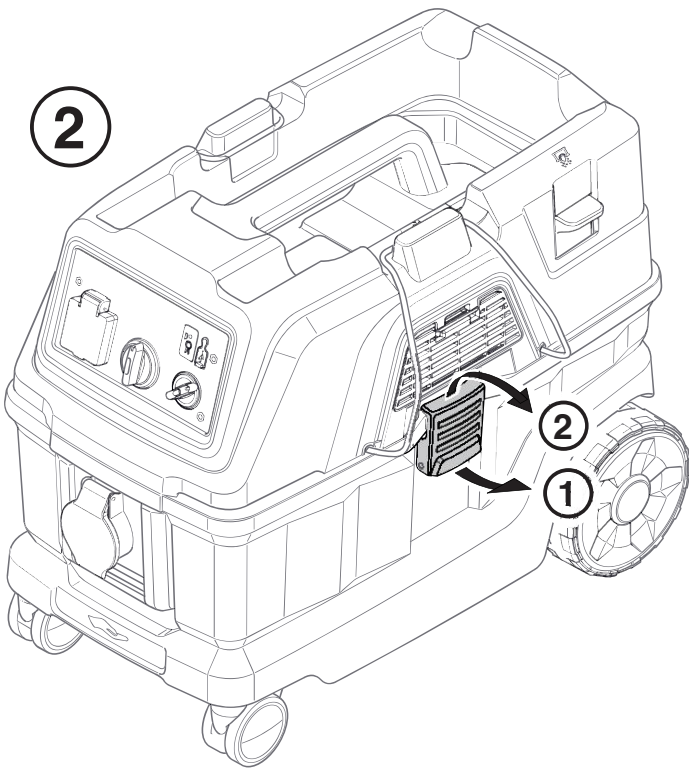

3

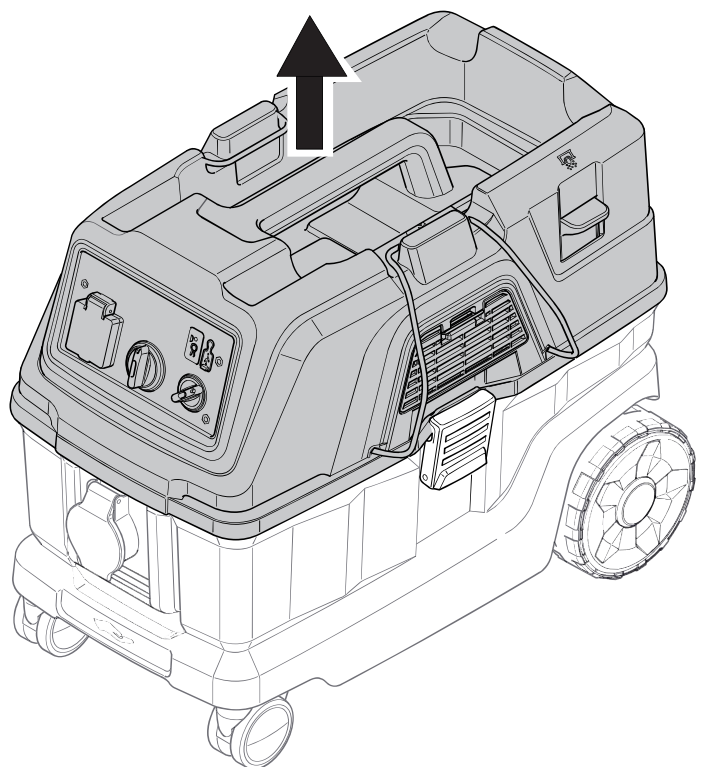



4

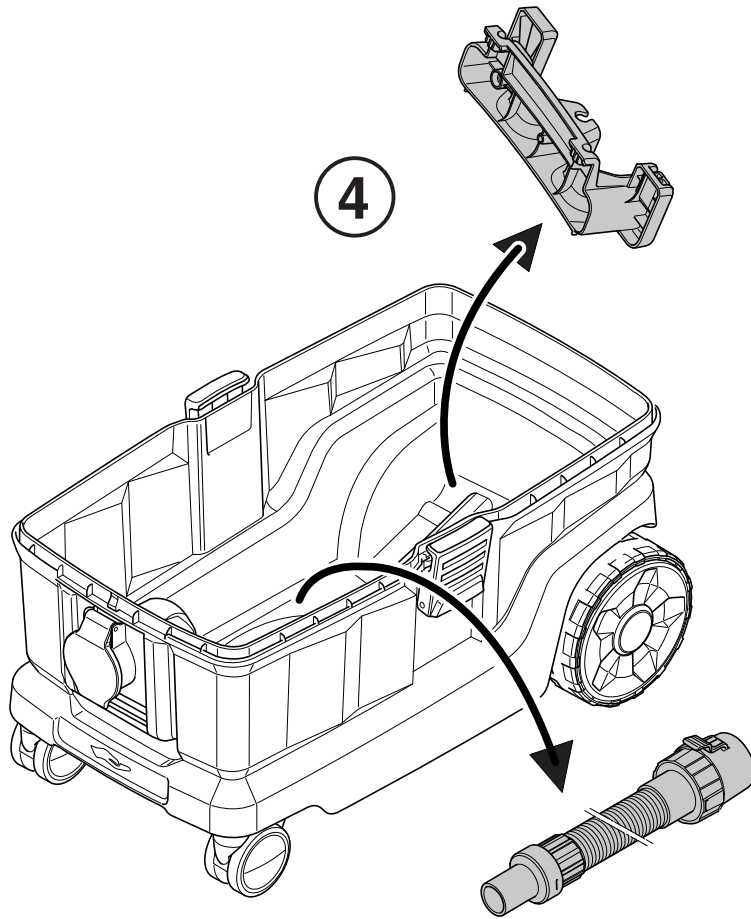

5

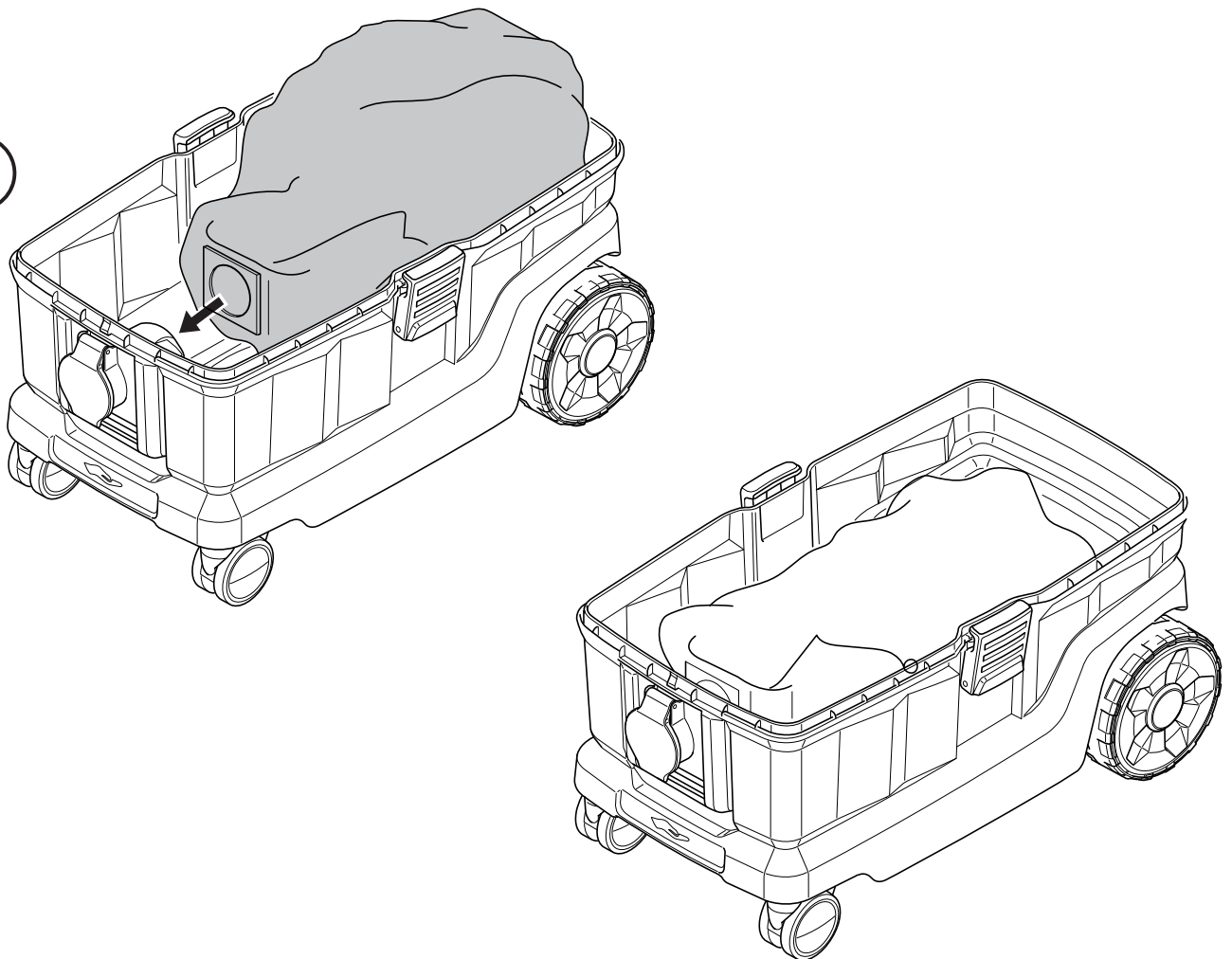



6

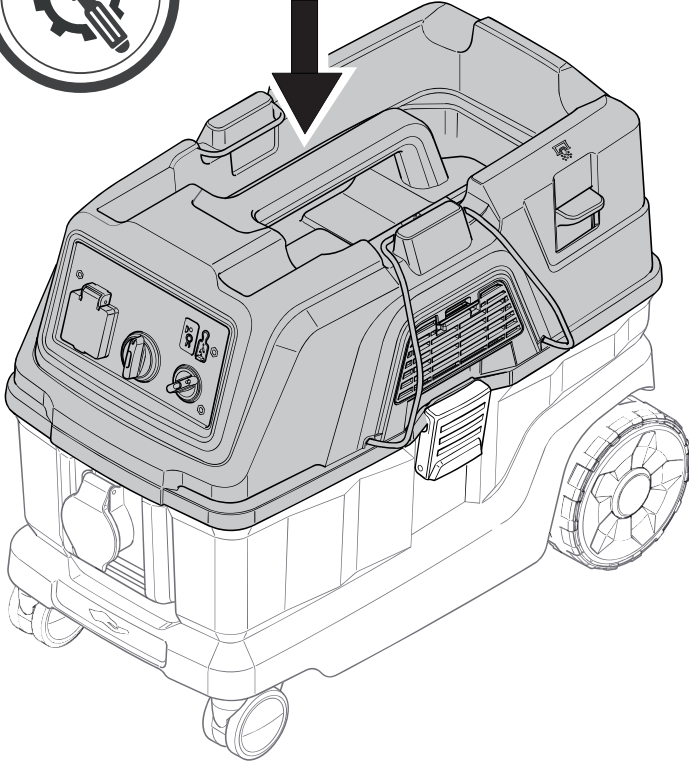

7

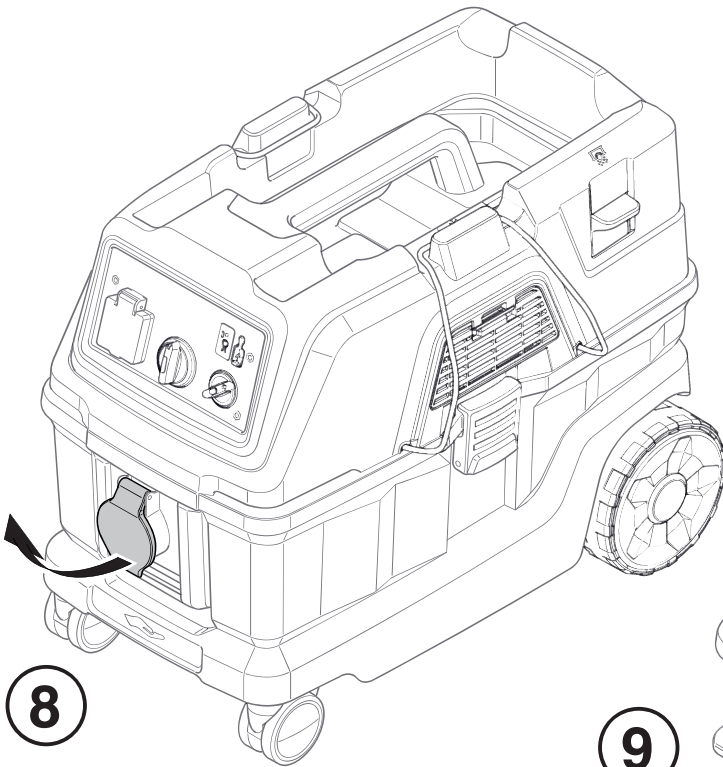
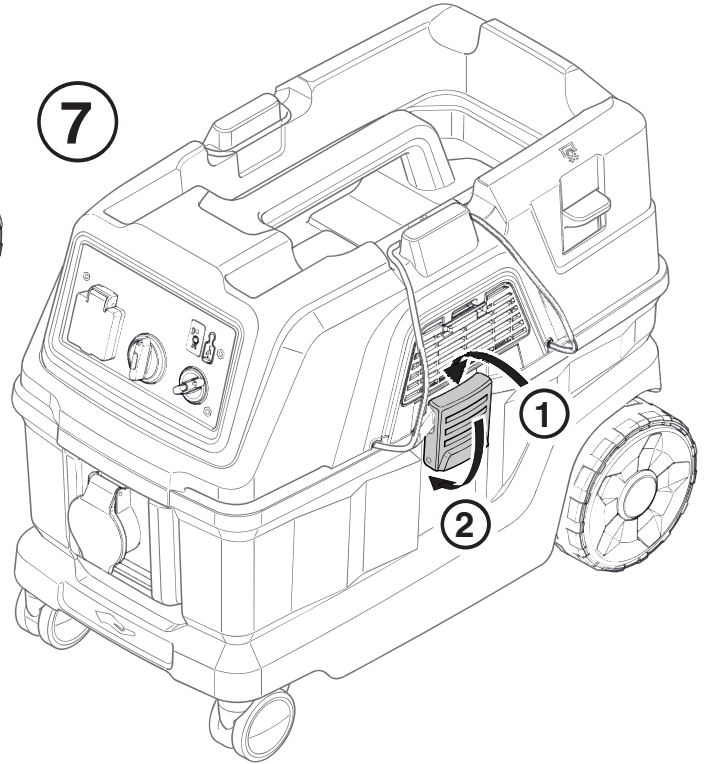

9

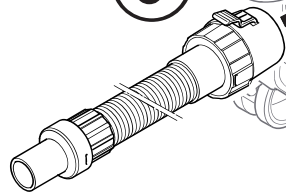



10

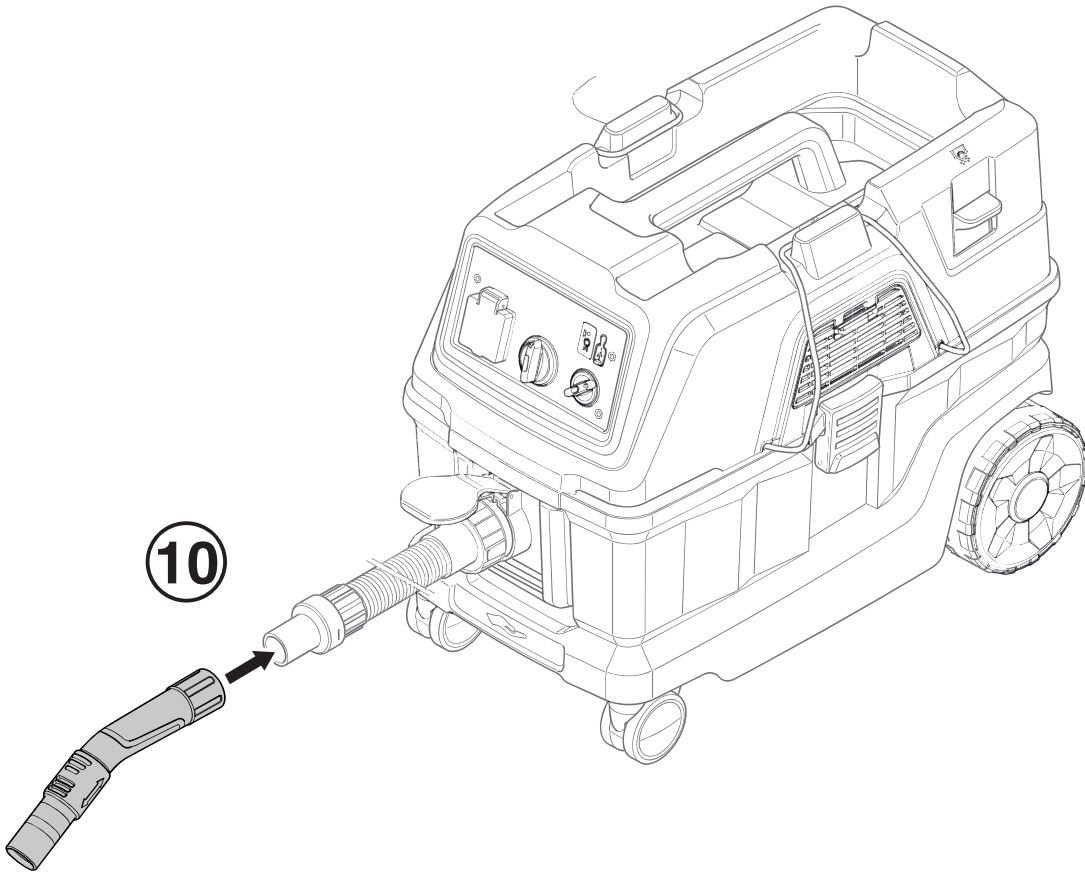

11

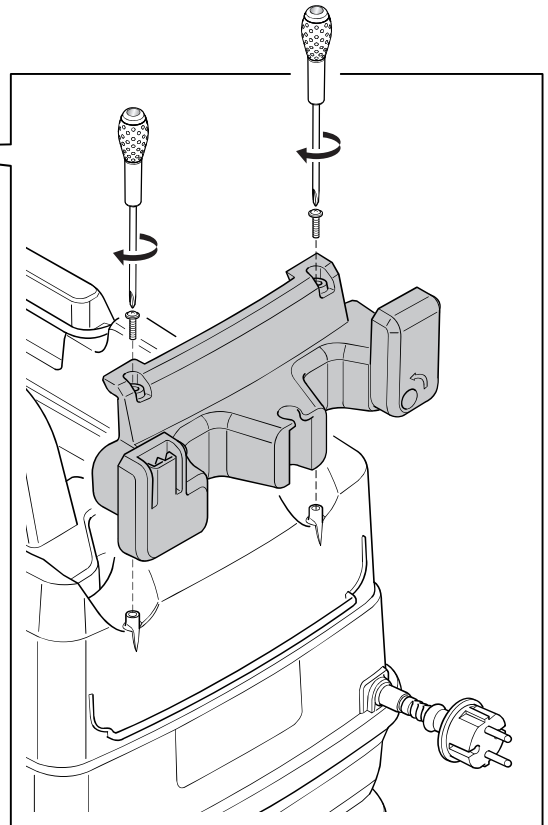
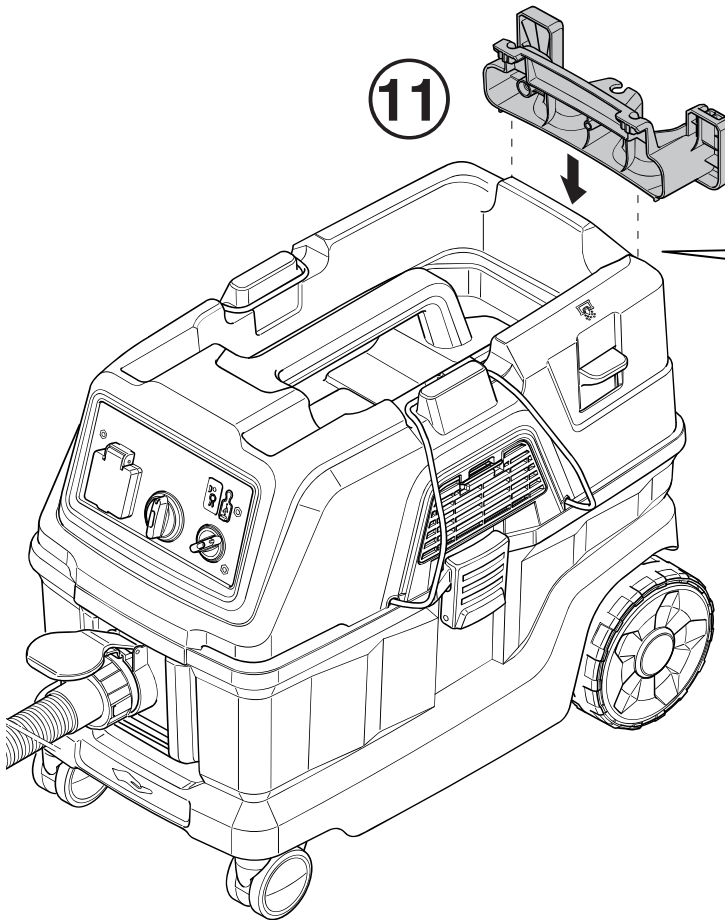

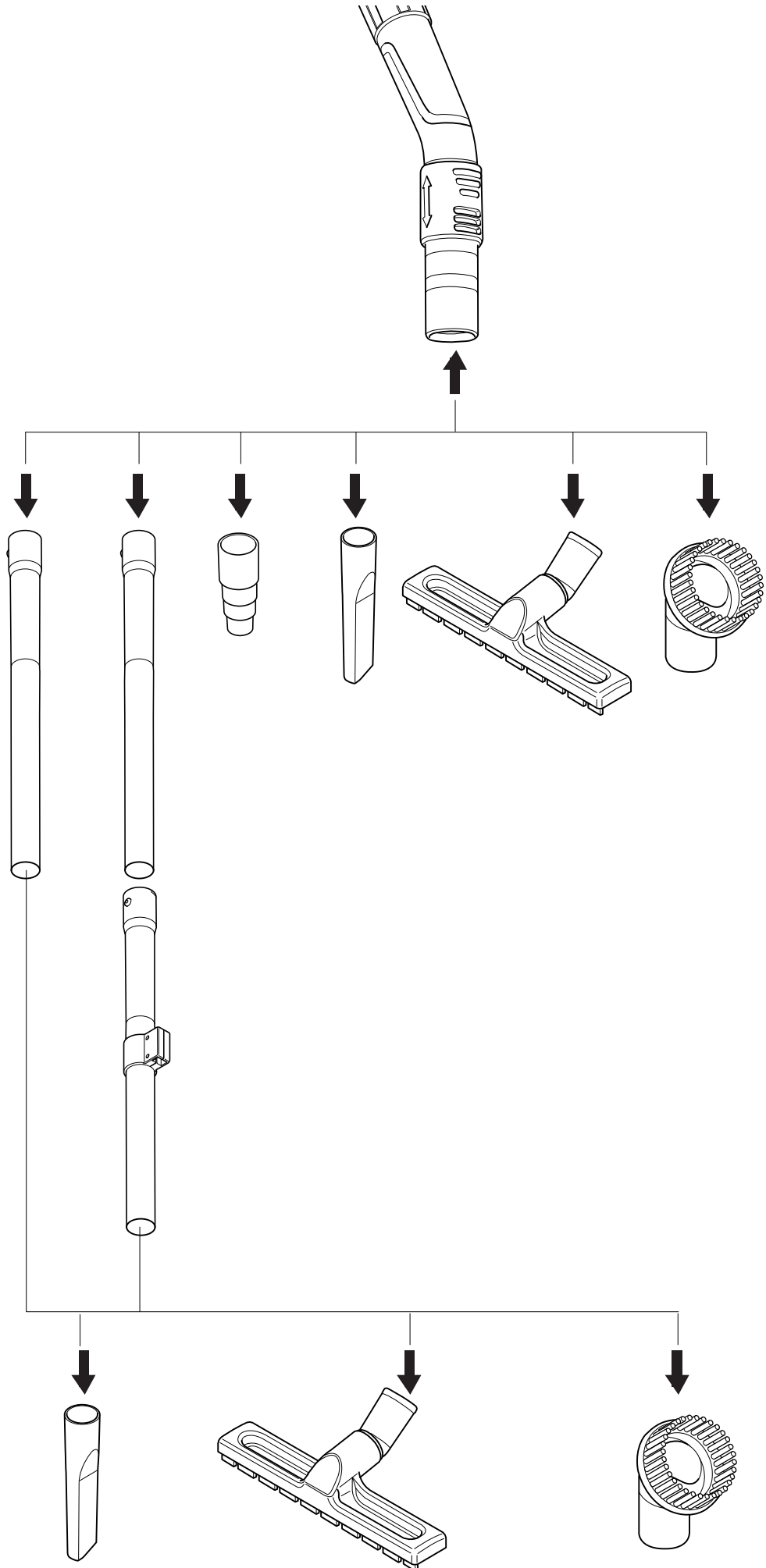

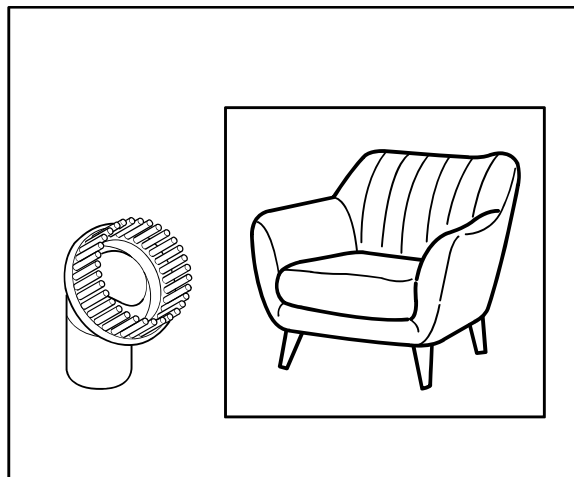
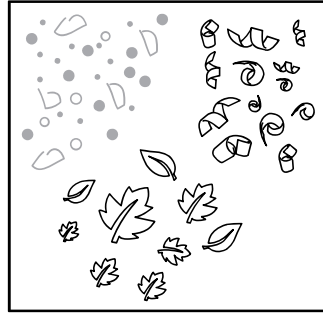
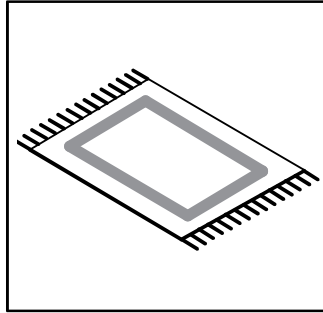
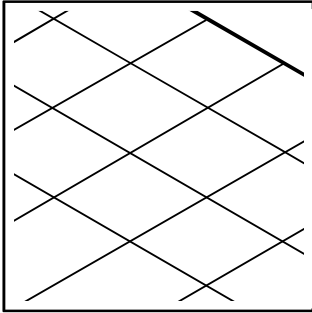
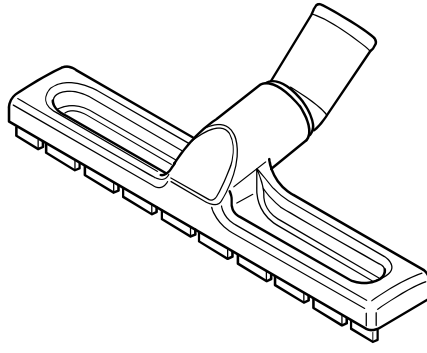
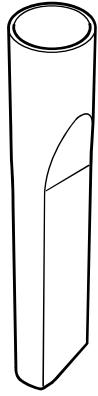

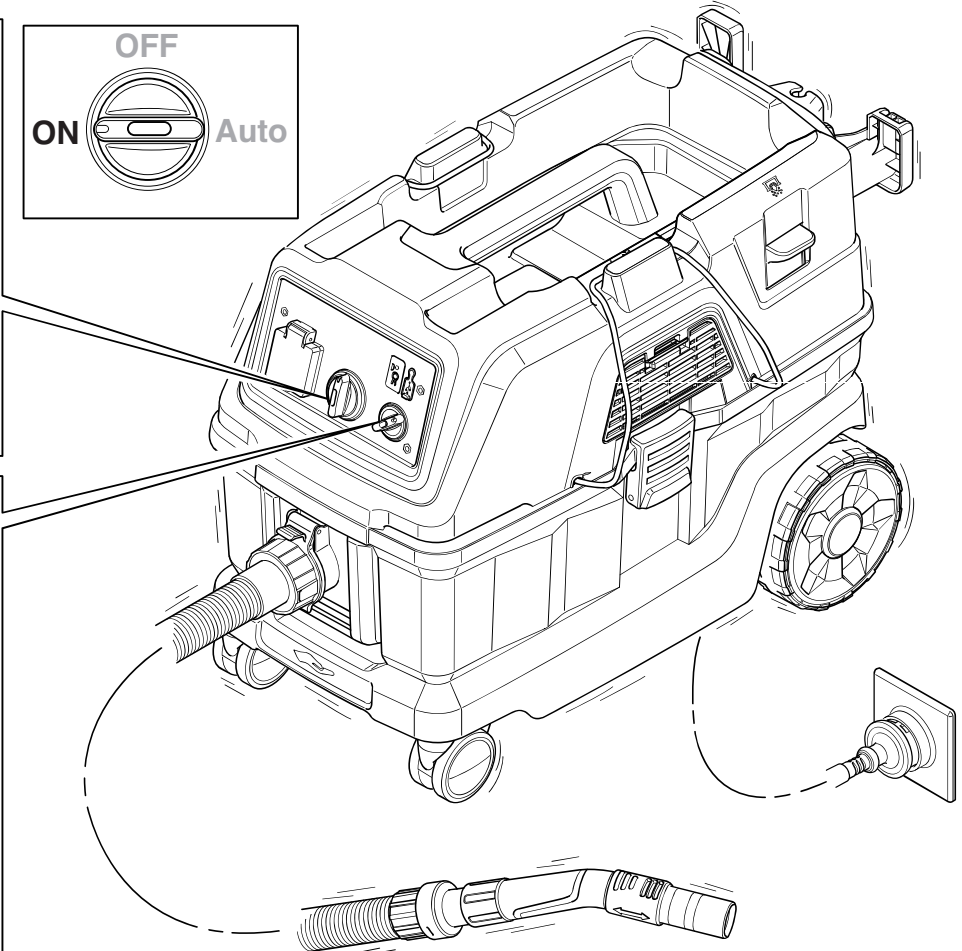
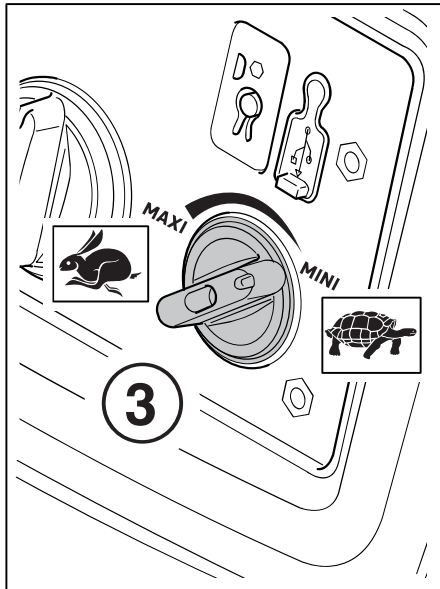
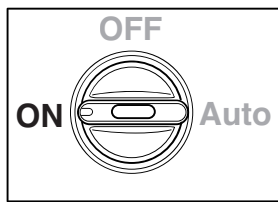
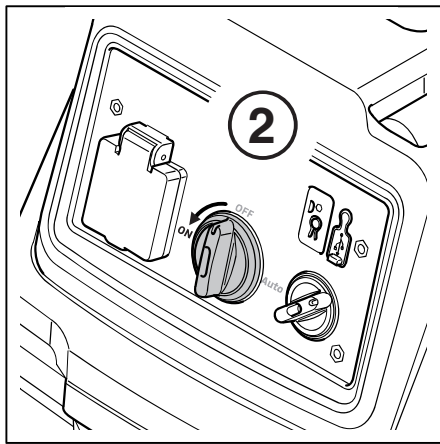
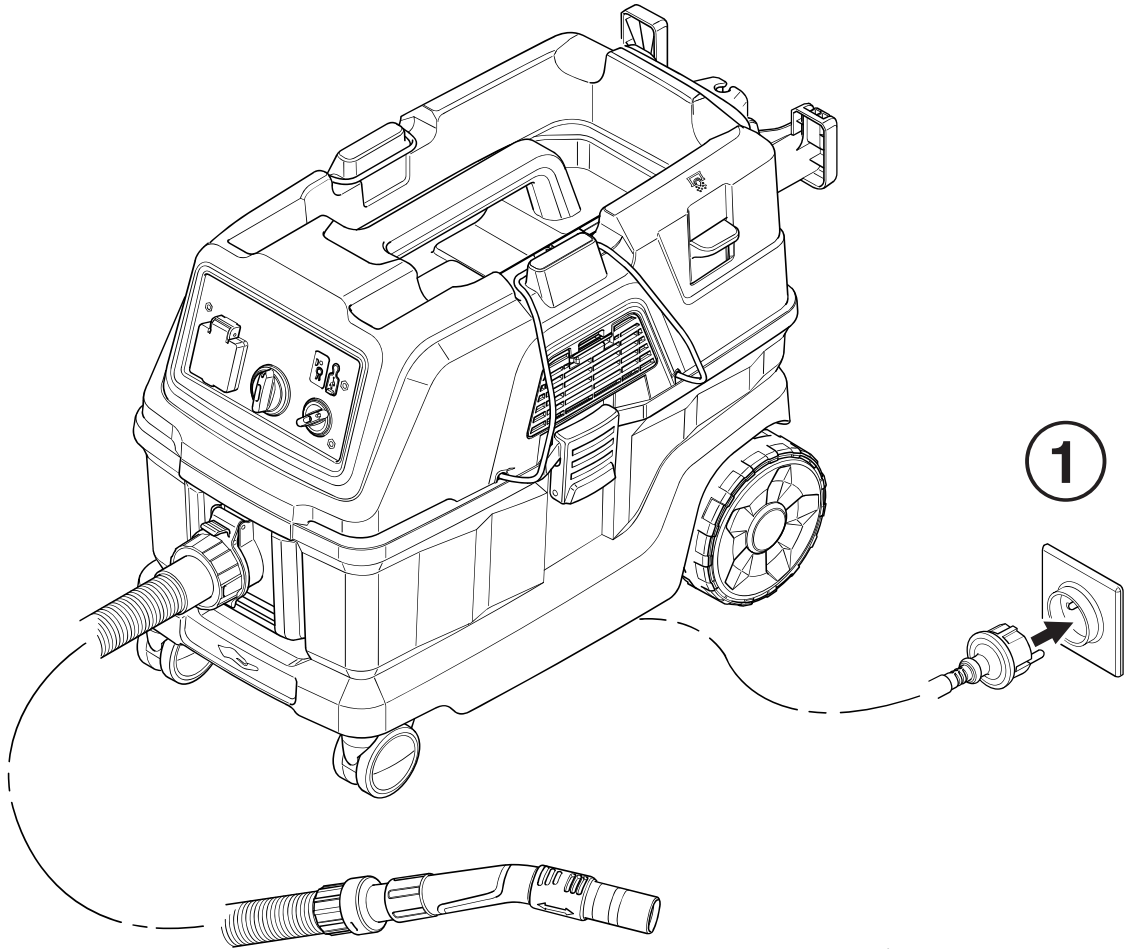

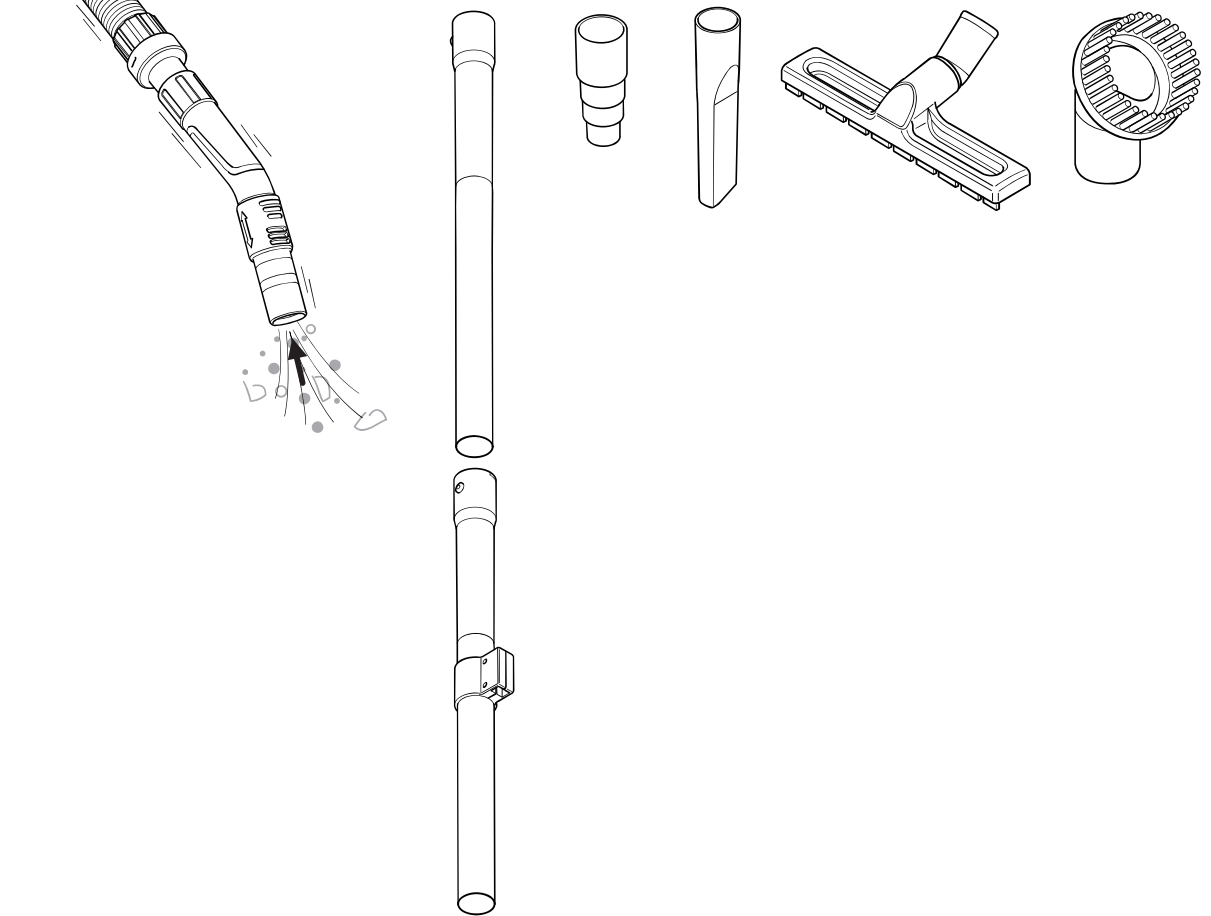
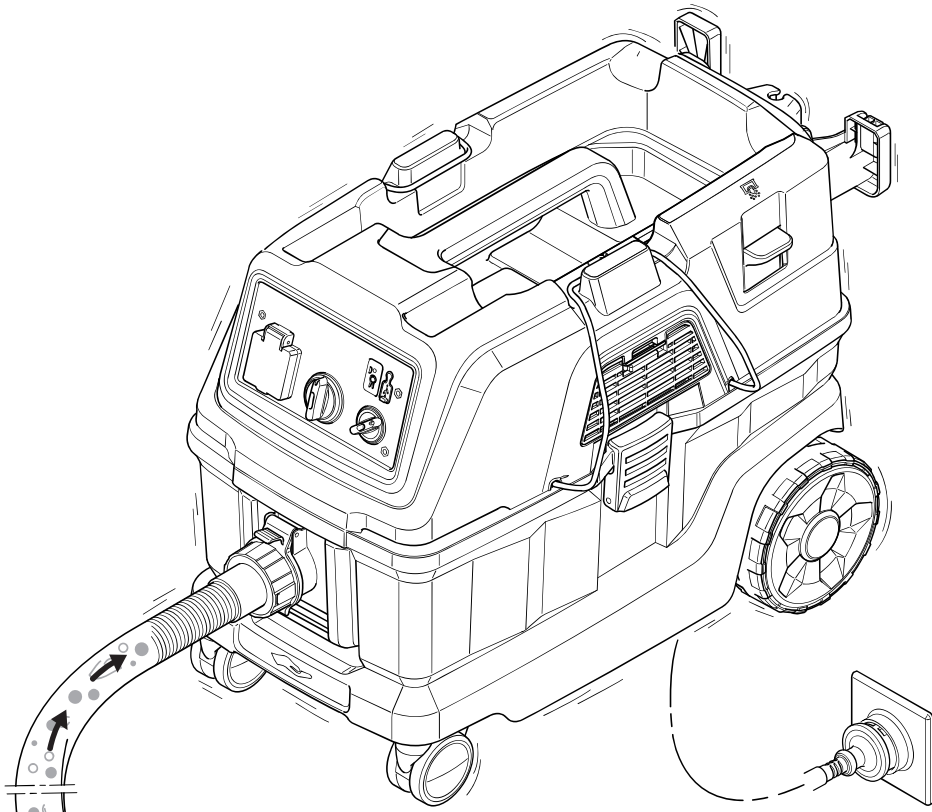

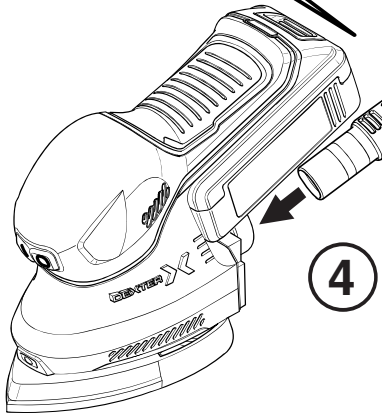
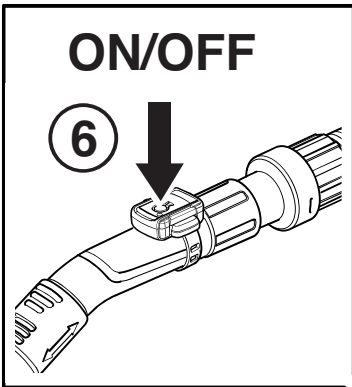
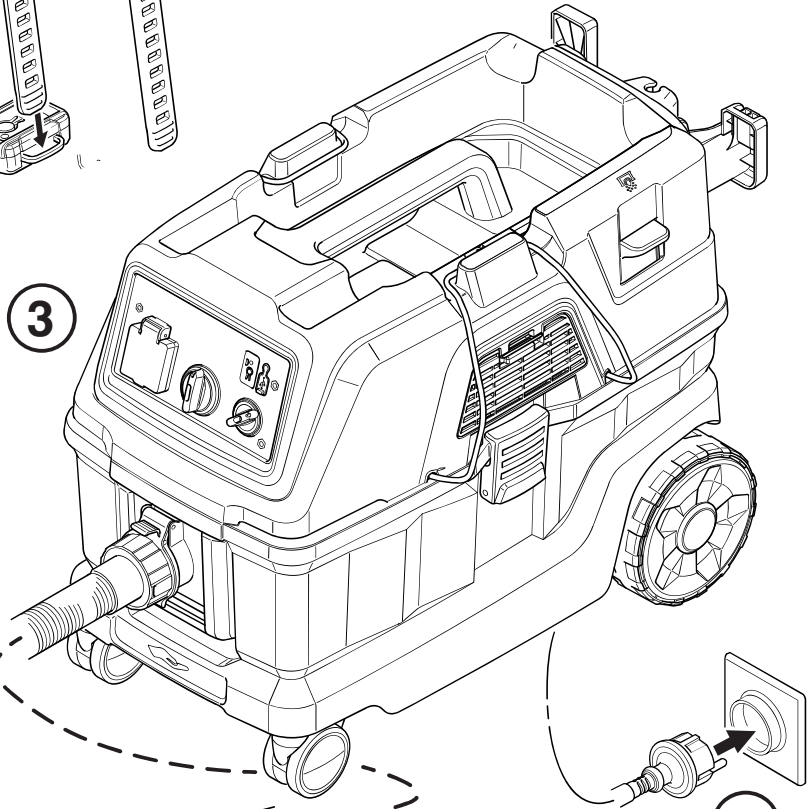
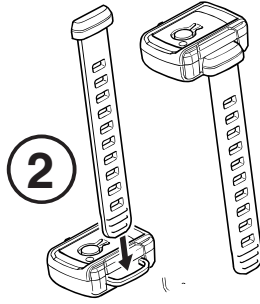
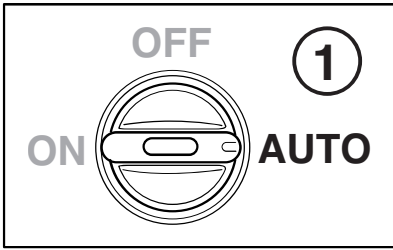

5

4

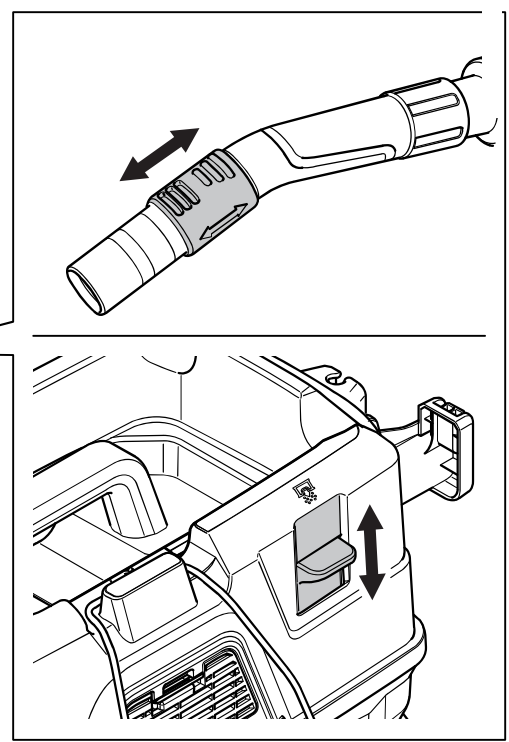
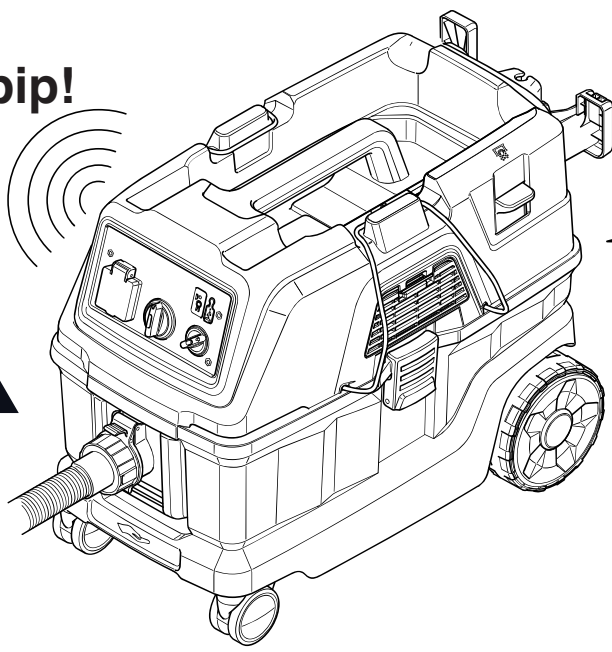

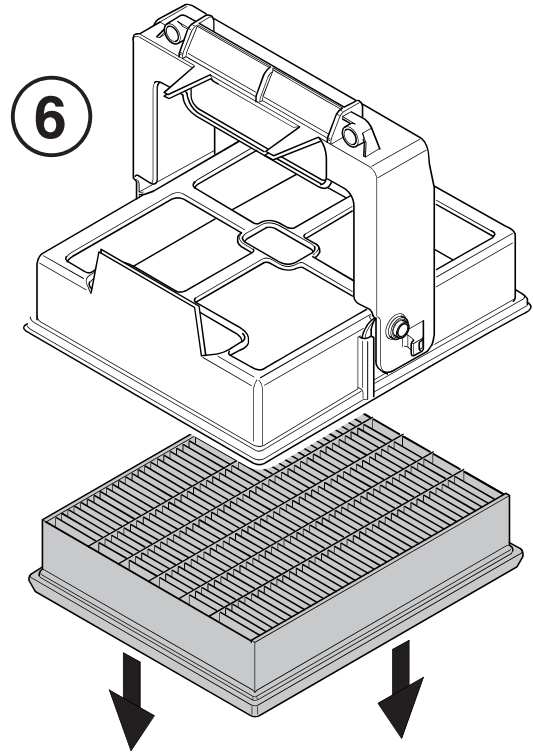
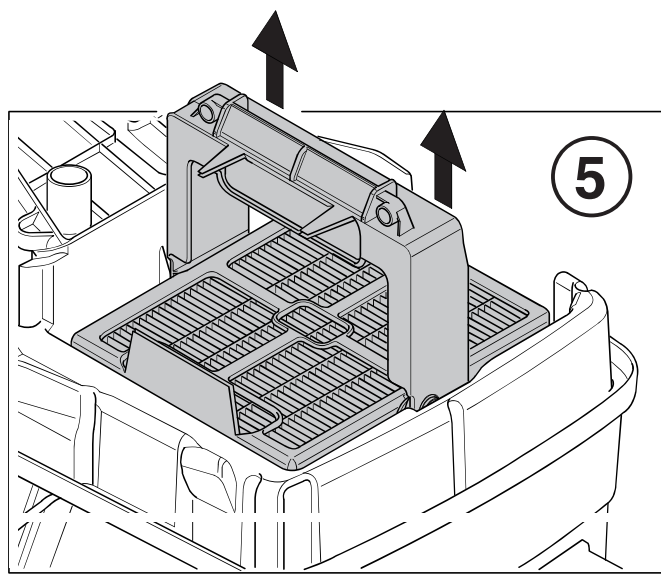
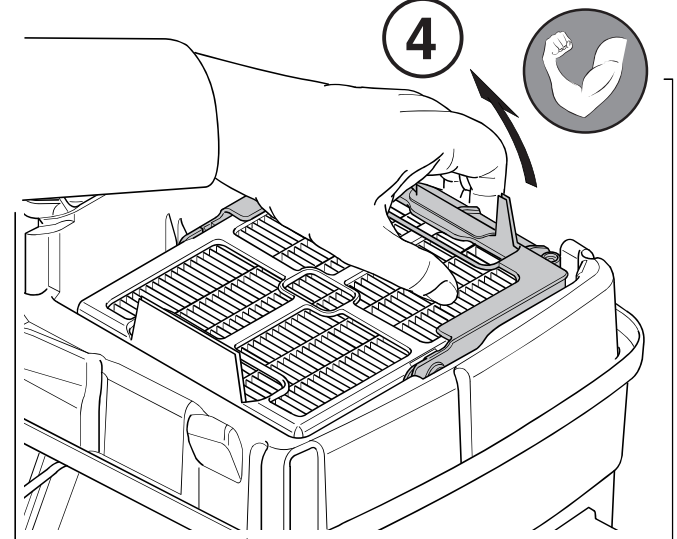
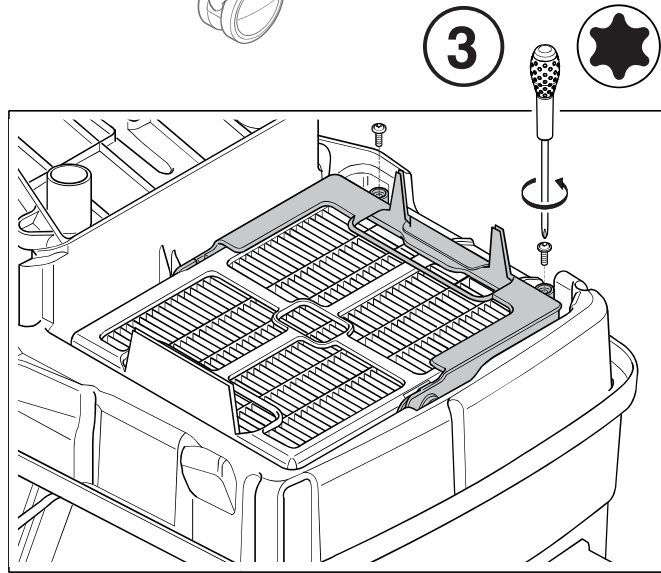
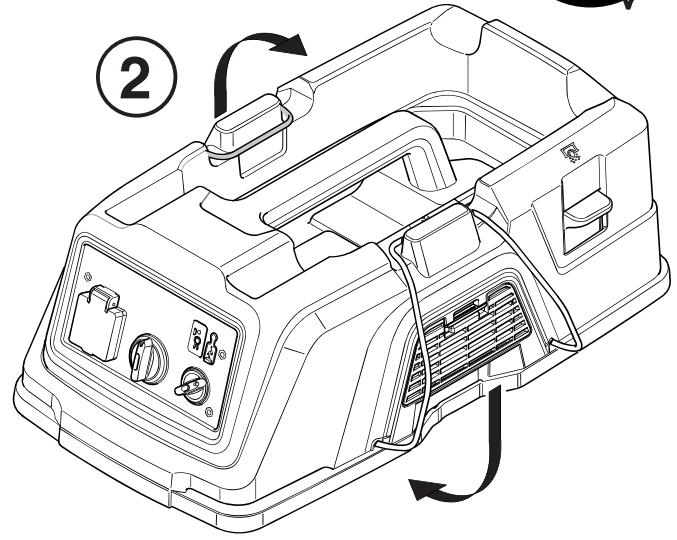
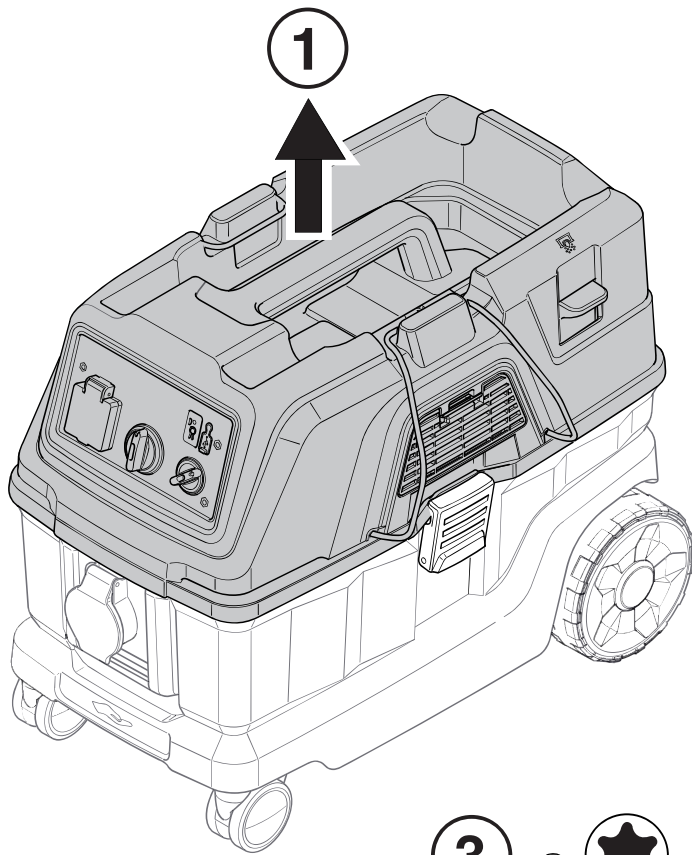



7

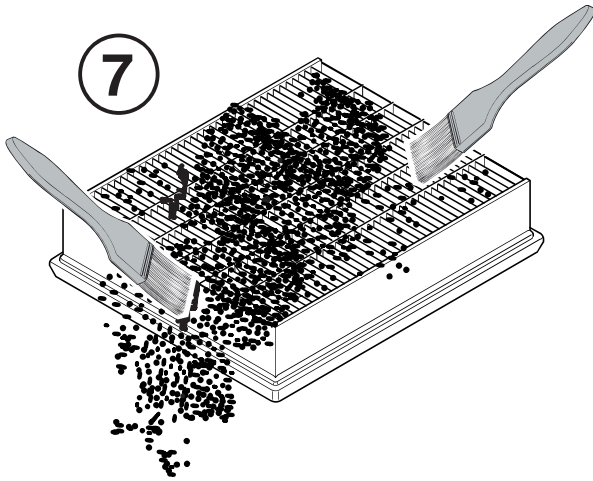

8

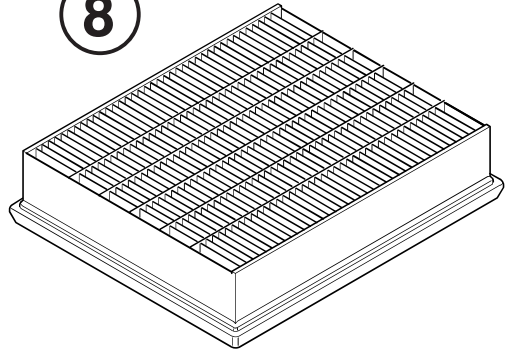

9

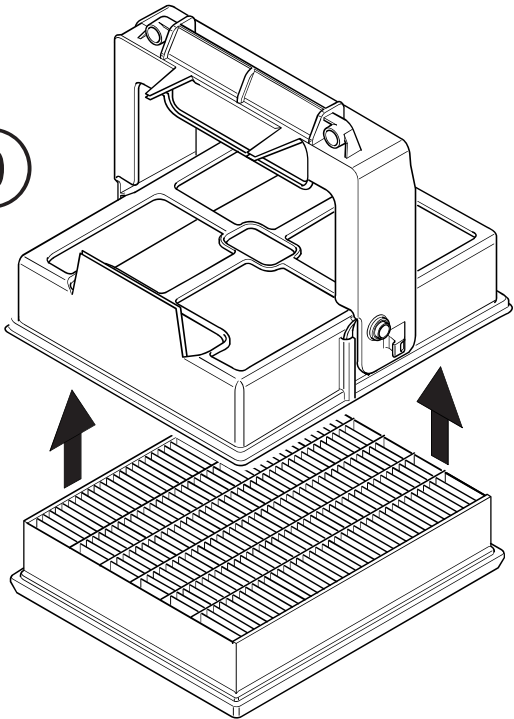

10

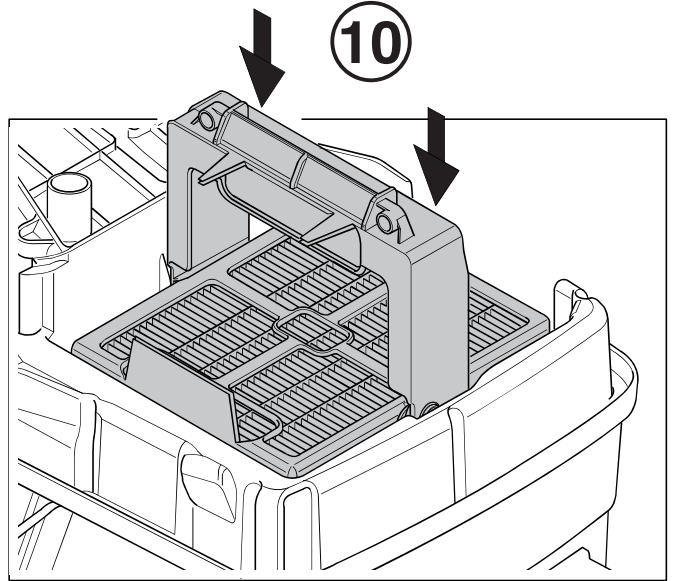

11



12

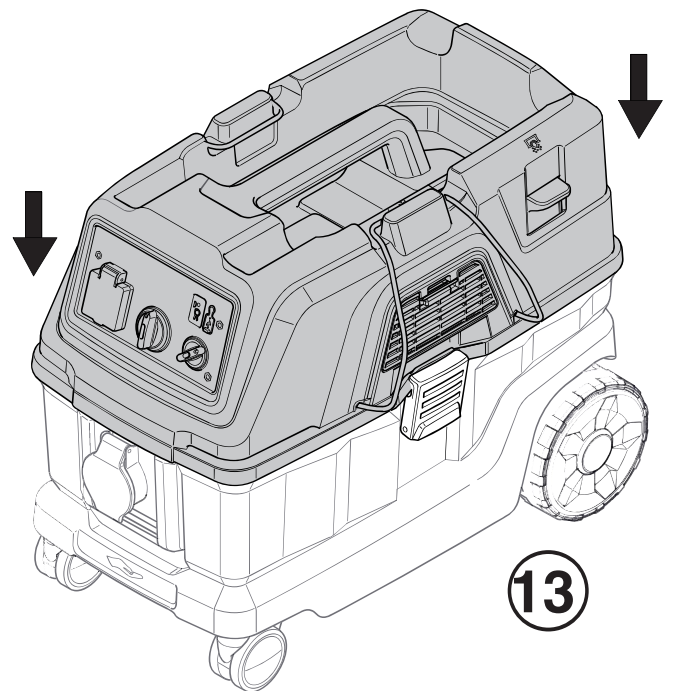
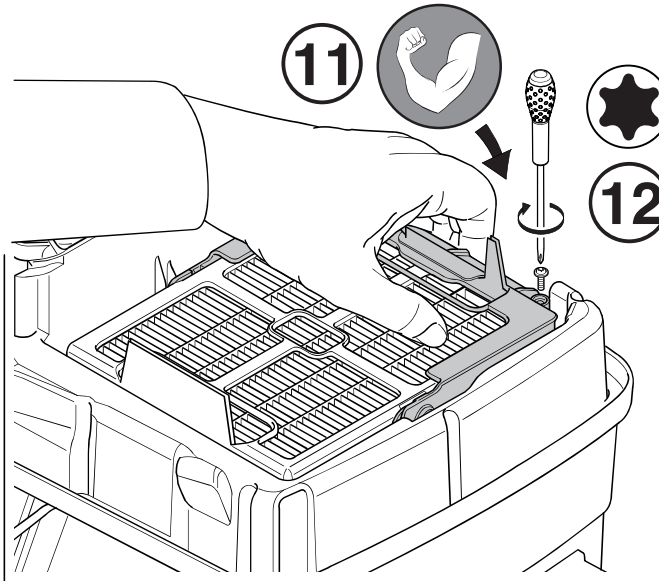

13

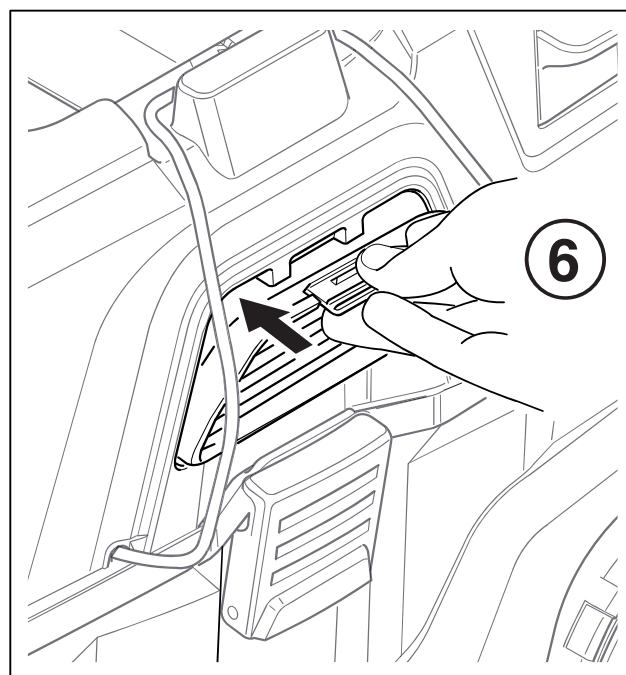
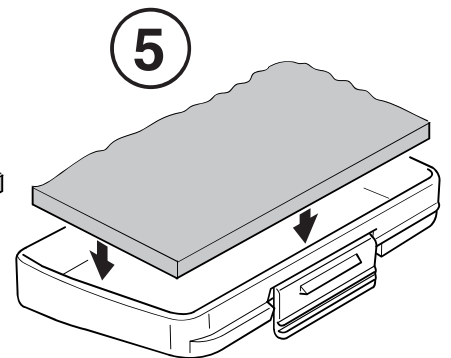
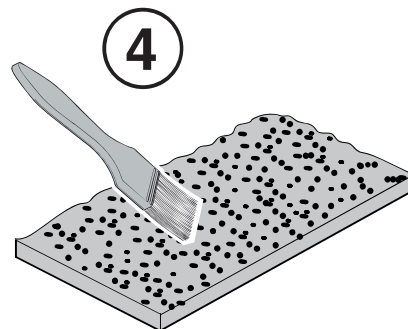
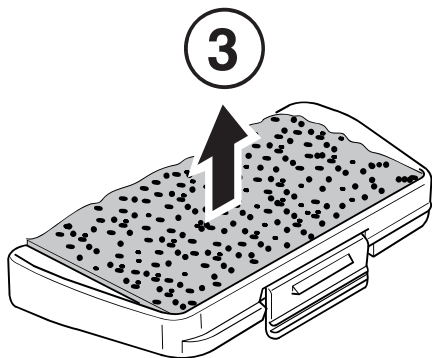
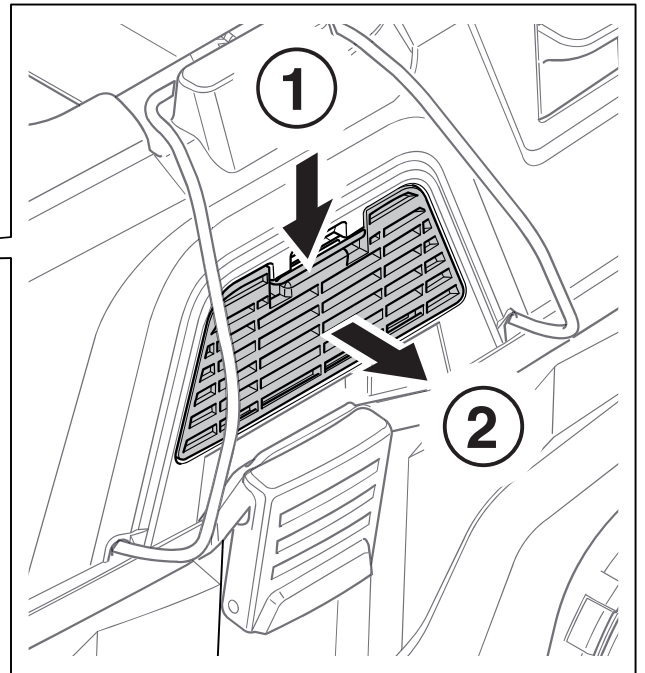
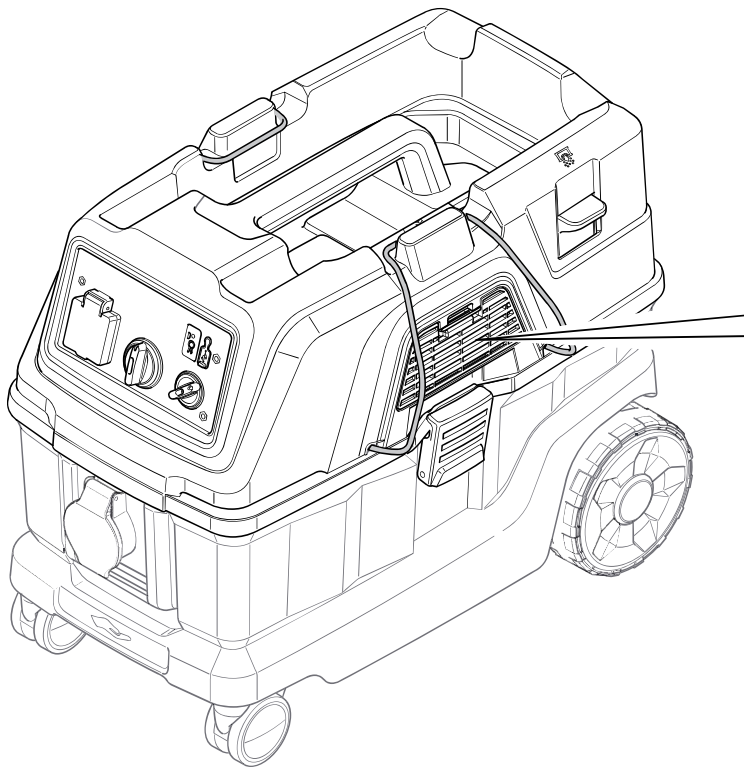

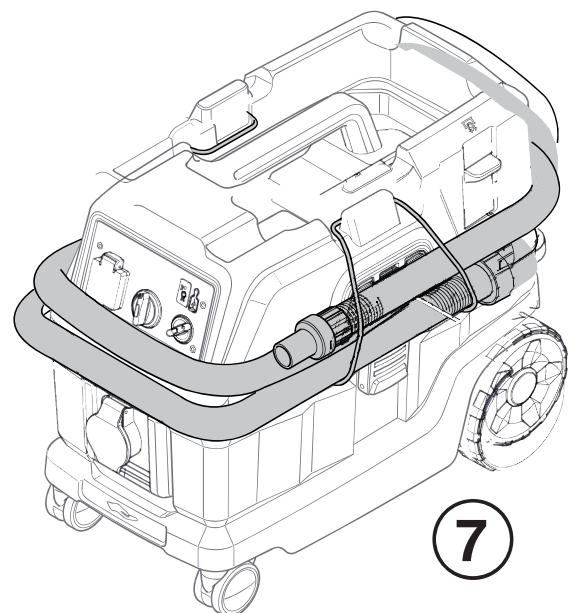
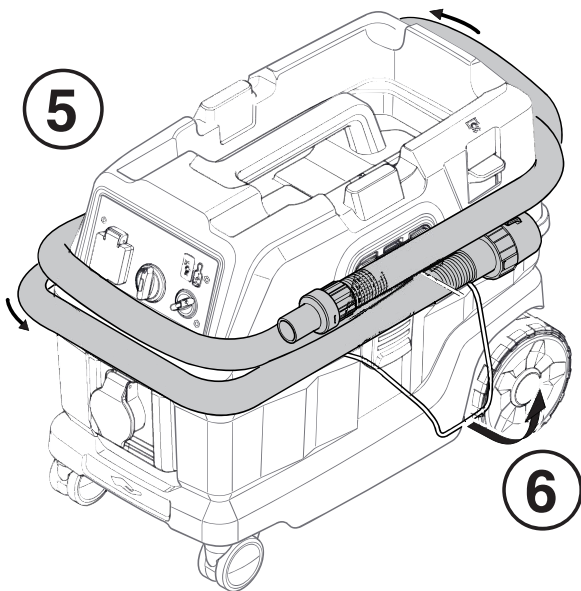
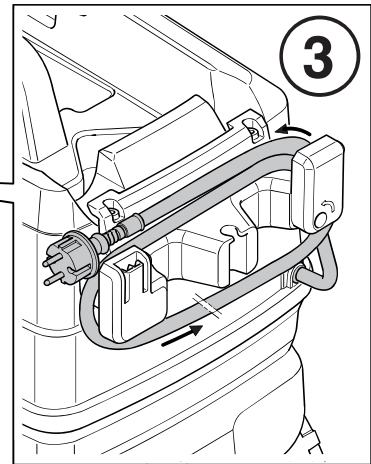
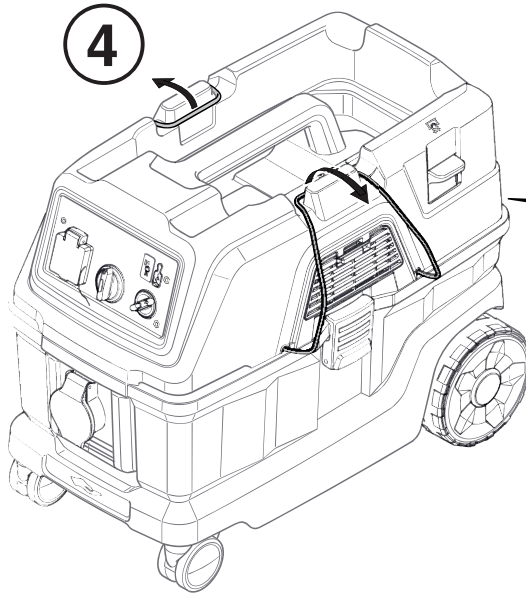
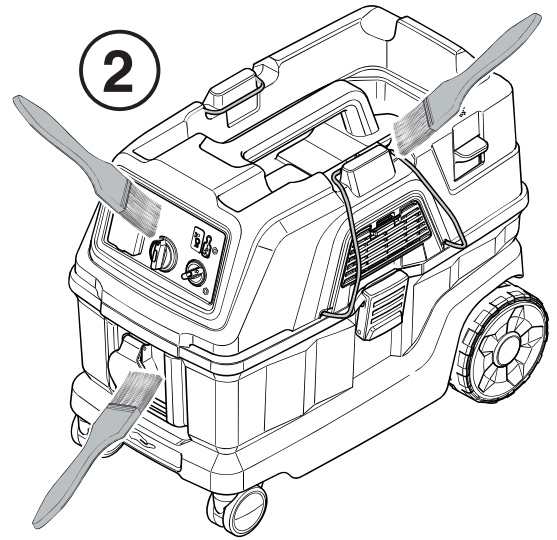
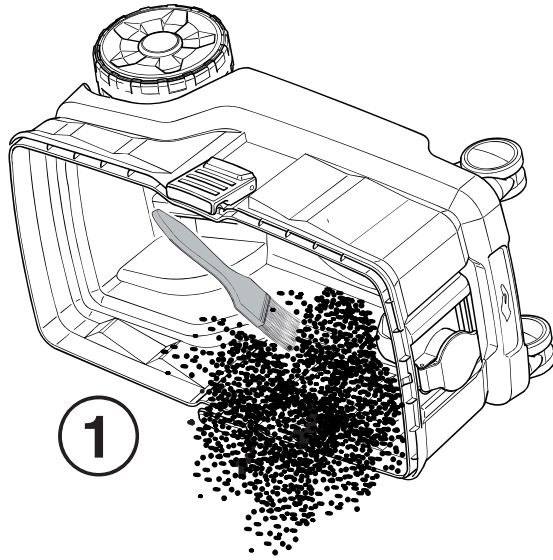

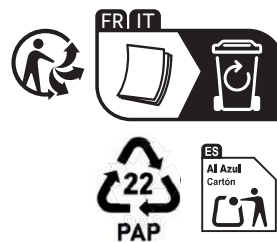

IT Raccolta Carta, verifica le disposizioni del tuo Comune.

FR. *Garantie 5 ans.
ES. *Garantía 5 años.
PT. *5 anos de garantia.

IT. *Garanzia di 5 anni.
EL. *Εγγύηση 5 έτη.
PL. *5 lat gwarancji.

UA. *Гарантія 5 років.
RO. *Garanție 5 ani.
EN. * 5-year warranty.



SERIAL NUMBER



Made in China / País de Origen: China / Країна походження: Китай

ADEO Services
135 Rue Sadi Carnot - CS00001
59790 RONCHIN - FRANCE
www.product-regulatory.adeoservices.com

Виробник: ТОВ «Адео Сервісез С.А.», вул. Саді Карно, CS 00001, 59790 Роншен, Франція. Імпортер, суб'єкт господарювання, що відповідає за виконання гарантійних зобов'язань: ТОВ «Леруа Мерлен Україна», 04201 Україна, м.Київ, вул. Полярна 17А, +380 44 498 46 00.

Imported by Adeo South Africa (PTY)
LTD T/A Leroy Merlin,
Hosted in Leroy Merlin Fourways Store,
35 Roos Street, Witkoppen Ext 97,
Sandton, 2191 Johannesburg, Gauteng,
South Africa
Tel: +27 10 493 8000 Email: contact@leroymerlin.co.za

Importado e distribuído por LEROY MERLIN COMPANHIA BRASILEIRA DE BRICOLAGEM CNPJ: 01.438.784/0001-05
Rua Pascoal Pais, nº. 525, 6º andar cj 61 a 64, Vila Cordeiro, São Paulo -SP. CEP: 04581-060
CALM (Central de Atendimento Leroy Merlin) Capitais 4020-5376
Demais Regiões 0800-0205376