

EAN : 3276007991574

Adeo key : 96673806

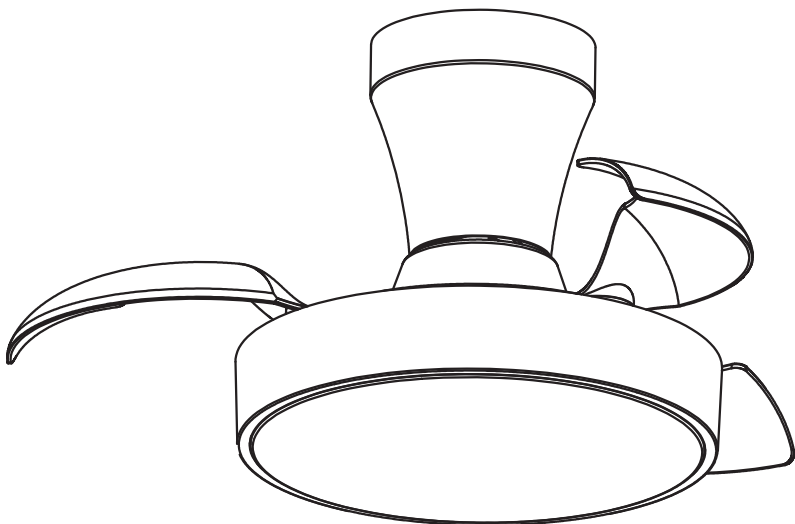

2/2

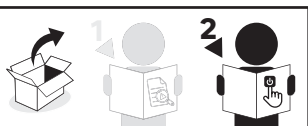

2025-11-V01

FR - Manuel d'Instructions

ES - Manual de Instrucciones

PT - Manual de Instruções

IT - Manuale di Istruzioni

EL - Εγχειρίδιο Οδηγιών

PL - Instrukcja Obsługi

UA - Інструкція з Експлуатації

RO - Manual de Instrucțiuni

BR - Manual de Instrução

NL - Handleiding

DE - Anleitung Handbuch

EN - Instructions Manual

*Année de garantie / años de garantía / Ano de garantia / Anno di garanzia / Έτος εγγύησης / Rok gwarancji / Гарантіяроків / Anul de garanție / Anos de garantia / Garantiejaar / Jahr der Garantie / Year of guarantee

** réparable / reparabile / reparável / riparabile / διορθώσιμος / naprawiany / ремонтний / reparabil / reparaturfähig / reparável / herstelbaar / reparierbar / repairable



FR : assemblage / **ES** : ensamblaje / **PT** : montagem / **IT** : assemblaggio /
EL : συναρμολόγηση / **PL** : montaż / **UA** : збірка / **RO** : asamblare /
BR : montagem / **NL** : samenstelling / **DE** : Montage / **EN** : assembly



FR : Utilisation / **ES** : Uso / **PT** : Utilização / **IT** : Utilizzo
EL : Χρήση / **PL** : Użycie / **UA** : Використання / **RO** : Utilizare /
BR : Utilização / **NL** : Gebruik / **DE** : Verwendung / **EN** : Use

FR : CARACTÉRISTIQUES TECHNIQUES / **ES** : CARACTERÍSTICAS TÉCNICAS /
PT : CARACTERÍSTICAS TÉCNICAS / **IT** : CARATTERISTICHE TECNICHE / **EL** : ΤΕΧΝΙΚΑ
ΧΑΡΑΚΤΗΡΙΣΤΙΚΑ / **PL** : CECHY TECHNICZNE / **UA** : ΤΕΧΝΙΚΗ ΧΑΡΑΚΤΗΡΙΣΤΙΚΗ /
RO : CARACTERISTICI TEHNICE / **BR** : CARACTERÍSTICAS TÉCNICAS / **NL** : TECHNISCHE KENMERKEN
DE : TECHNISCHE MERKMALE / **EN** : TECHNICAL SPECIFICATIONS

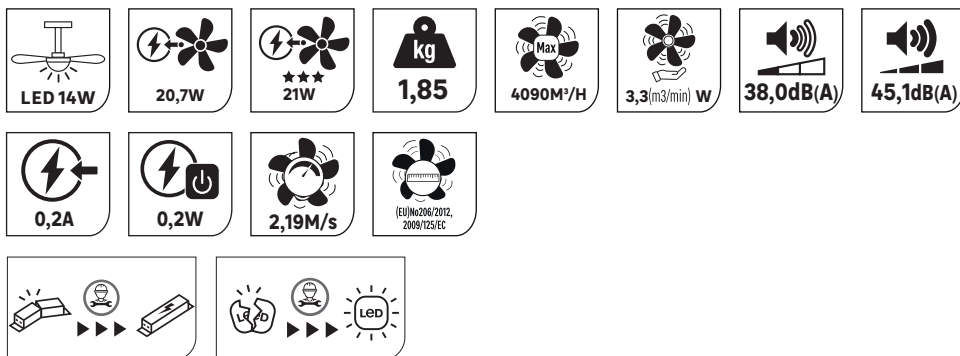
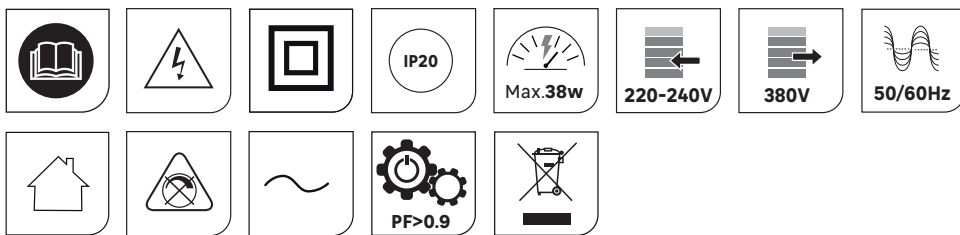

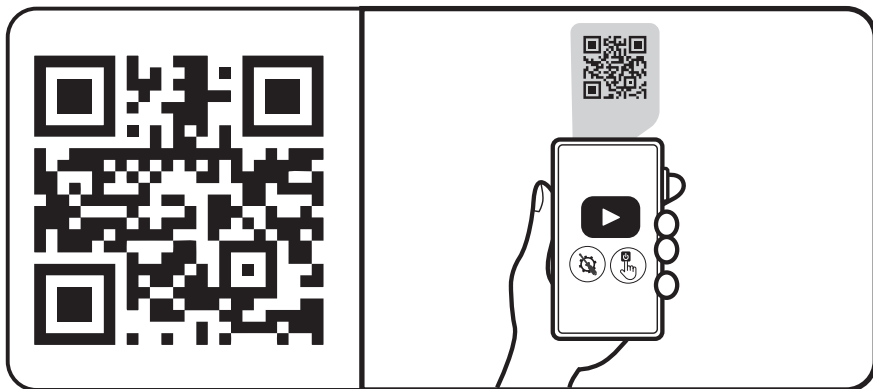

FR: Scannez ce code QR pour voir la vidéo de montage et d'utilisation.

ES: Escanee este código QR para ver el video de montaje y uso.

PT: Digitalize este código QR para ver o vídeo de montagem e utilização.

IT: Scansiona questo codice QR per vedere il video di montaggio e utilizzo.

EL: Σαρώστε αυτόν τον κωδικό QR για να δείτε το βίντεο συναρμολόγησης και χρήσης.

PL: Zeskanuj ten kod QR, aby zobaczyć film instruktażowy dotyczący montażu i użytkowania.

UA: Відскануйте цей QR-код, щоб переглянути відео про монтаж та використання.

RO: Scanți acest cod QR pentru a vedea videoclipul de montare și utilizare.







BR: Digitalize este código QR para ver o vídeo de montagem e utilização.

NL: Scan deze QR-code om de montage- en gebruiksvideo te bekijken.

DE: Scannen Sie diesen QR-Code, um das Montage- und Anwendungsvideo zu sehen.

EN: Scan this QR code to see the assembly and usage video.

FR - Ce produit contient une source lumineuse de classe d'efficacité énergétique **C** (EU) 2019/2015
ES - Este producto contiene una fuente de luz de clase de eficiencia energética **C** (EU) 2019/2015
PT - Este produto contém uma fonte luminosa de classe de eficiência energética **C** (EU) 2019/2015
IT - Questo prodotto contiene una sorgente luminosa di classe di efficienza energetica **C** (EU) 2019/2015
EL - Αυτό το προϊόν περιέχει μια πηγή φωτός τάξης ενεργειακής απόδοσης **C** (EU) 2019/2015
PL - Ten produkt zawiera źródło światła o klasie efektywności energetycznej **C** (EU) 2019/2015
UA - Цей продукт містить джерело світла класу енергоєфективності **C** (EU) 2019/2015
RO - Acest produs conține o sursă de lumină de clasă de eficiență energetică **C** (EU) 2019/2015
BR - Este produto contém uma fonte luminosa de classe de eficiência energética **C** (EU) 2019/2015
NL - Dit product bevat een lichtbron met energie-efficiëntieklasse **C** (EU) 2019/2015
DE - Dieses Produkt enthält eine Lichtquelle der Energieeffizienzklasse **C** (EU) 2019/2015
EN - This product contains a light source of energy efficiency class **C** (EU) 2019/2015

	1	2	3	4	5	6
 W	6,1	8,2	12,0	14,4	17,4	20,7
 RPM	329	352	382	409	434	457
 m ³ /H	1870	2490	3210	3550	3680	4090
 m ³ /min/W	5,2	5,2	4,5	4,2	3,6	3,4
 XXdB	38,0	39,2	40,5	42,0	43,4	45,1

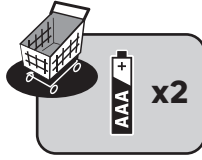

Ø6mm

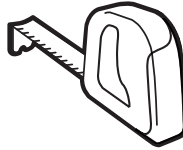

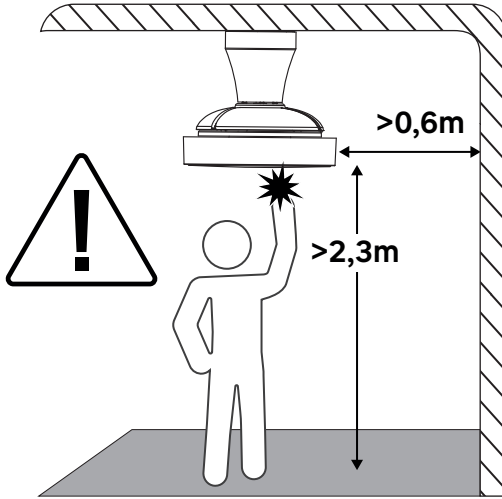
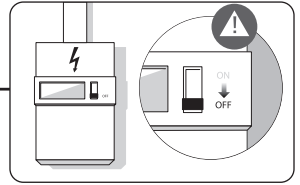

1

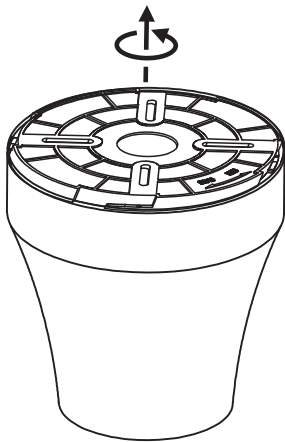

B

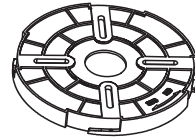

+

C

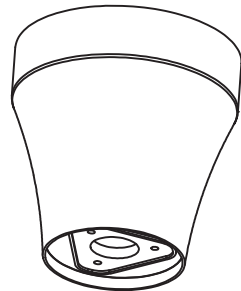

2

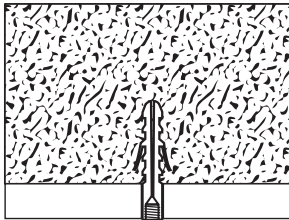
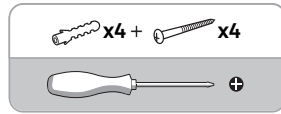
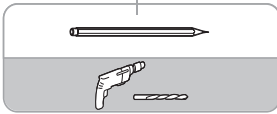
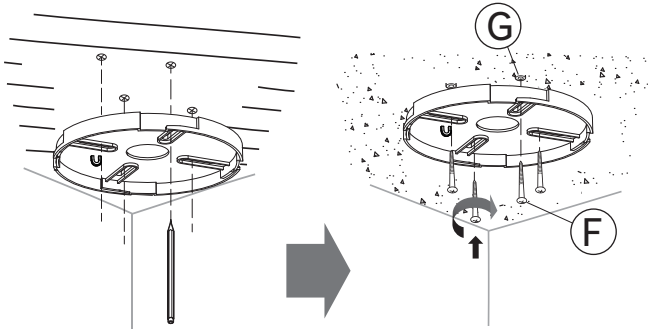

INCLUDED

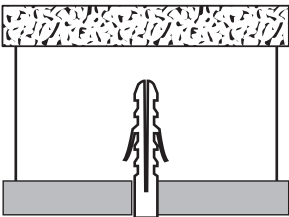
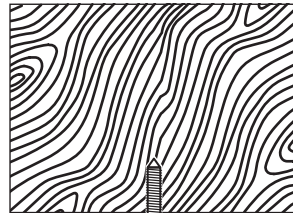

NOT INCLUDED

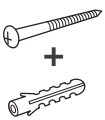
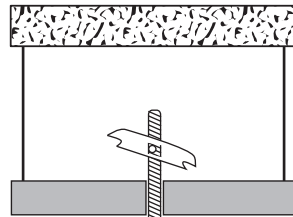

Utiliser des vis et des chevilles adaptées à votre support / Utilice tacos y tornillos adecuados al soporte / Utilize buchas e parafusos adequados ao seu suporte / Utilizzare viti e tasselli adatti per il retro / Χρησιμοποιήστε βίδες και βύσματα που ταιριάζουν στην επιφάνεια στήριξης. / Należy użyć śrub i kołków odpowiednich dla podłoża / Використовуйте гвинти та шканти, призначені для задньої поверхні. / Utilizați șuruburi și dibluri adecvate pentru suportul dvs. / Use parafusos e buchas adequados para seu suporte / Verwenden Sie für Ihre Unterlage geeignete Schrauben und Dübel / Use screws and dowels suited to your backing

3

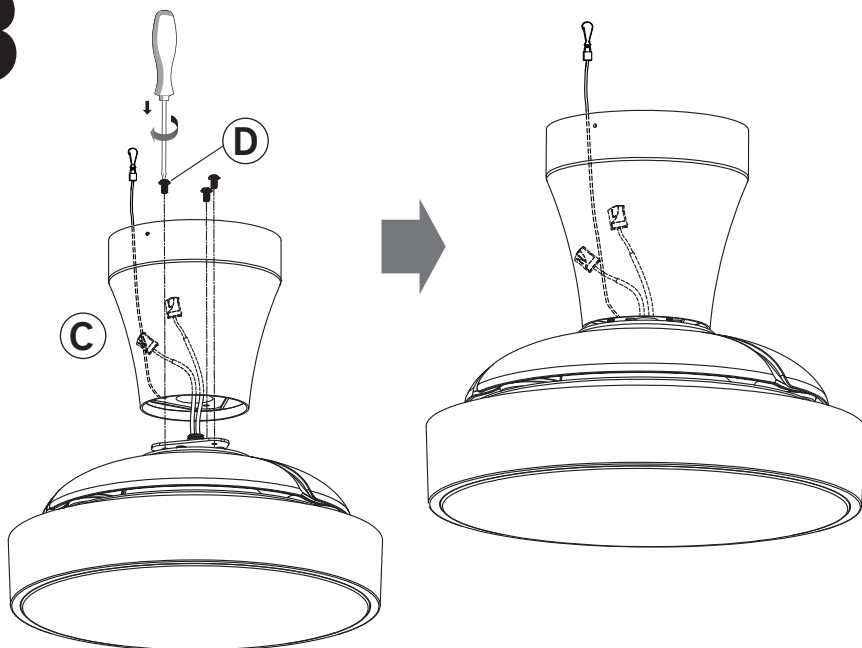

4

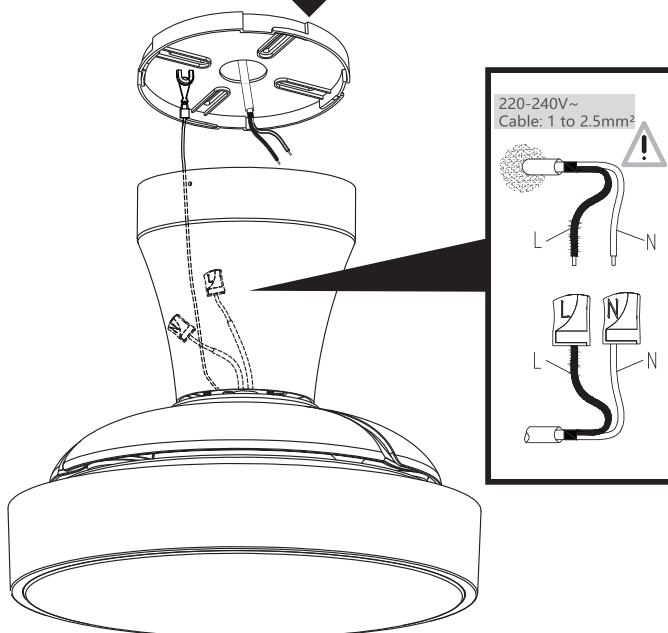

N =Bleu/Azul/Azul/Vlu/Μπλε/Niebieski/ Синій/Albastru/Azul/Blau/Blue

L =Marron/Ma rrón/Castanho/Ma rrone/Καφέ/Brązowy/
Кори чневий/Ma ro/Ma rrom/B raun/Brown

5

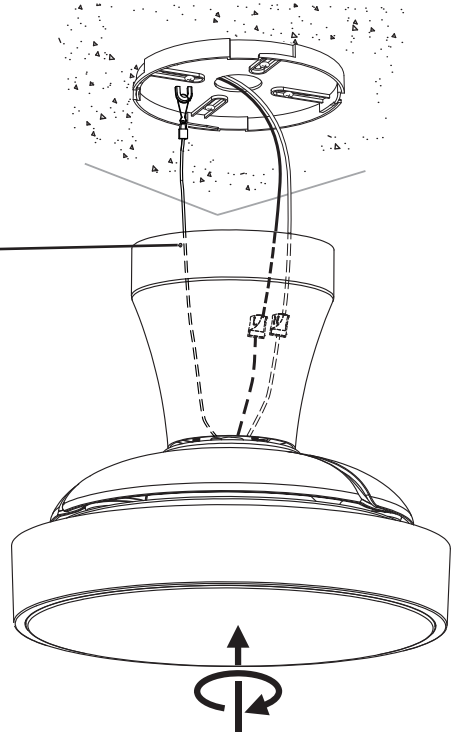
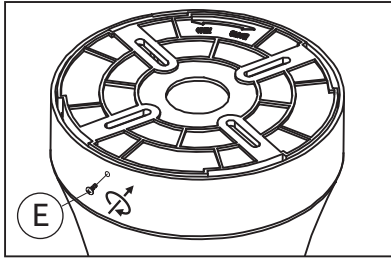

6

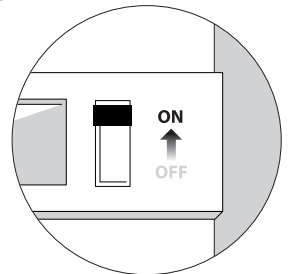
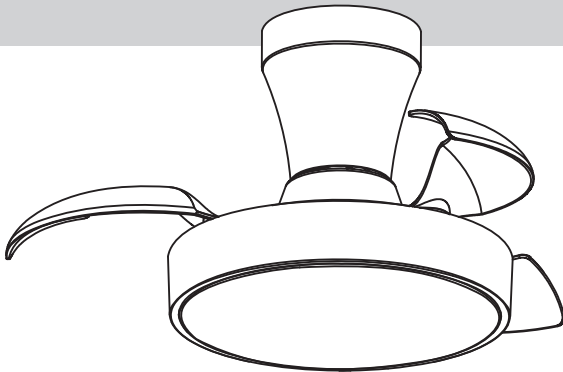



1

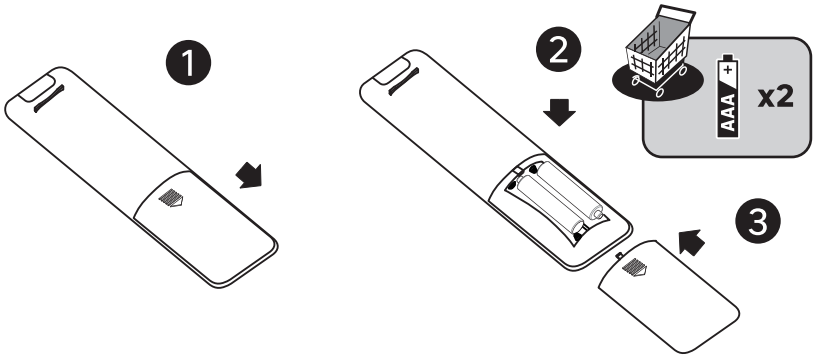

2

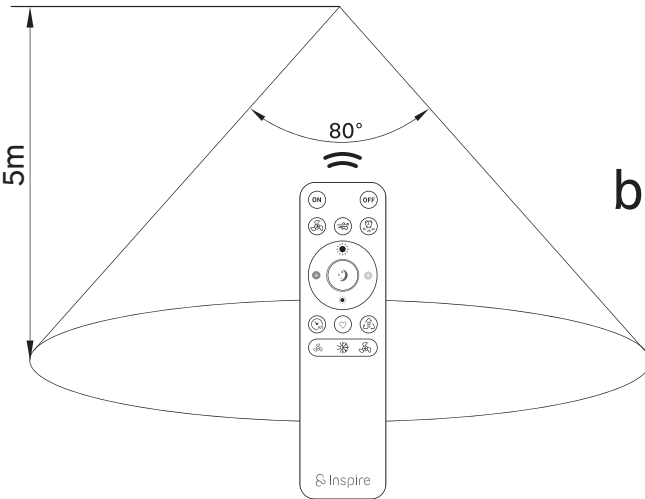

a.

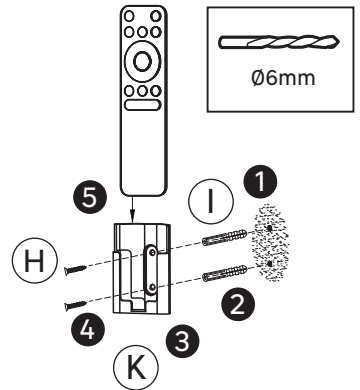

b.

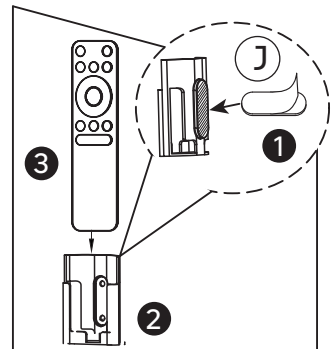

3

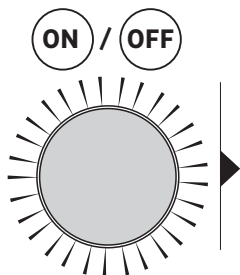

6500K



2700K

bleu/azul/βlu/μπλε/niebieski/блак | Jaune/Amarillo/Amarelo/Giallo/Κίτρινο/
итний/albastru/blauw/blau/blue | Żółty/Жовтий/Gelben/Geel/Gelb/Yellow



10%



100%

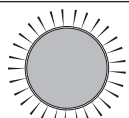

2700K

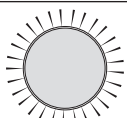

4000K

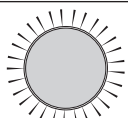

6500K

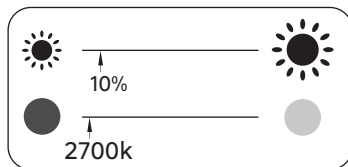
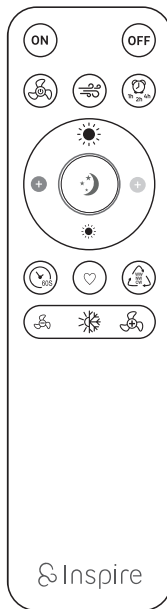

>3 sec

mémoriser le dernier réglage / recordar la última configuración /
memorizar a última configuração / memorizzare l'ultima impostazione /
αποθηκεύστε την τελευταία ρύθμιση / zapamiętać ostatnie ustawienie /
запам'ятати останнє налаштування / memorarți ultima setare /
memorizar a última configuração / de laatste instelling onthouden / die
letzte Einstellung speichern / remember the last setting



ON



Minuterie/Temporizador/
Χρονοδιακόπτης/Minutnik/
Таймер/Cronometru/Timer

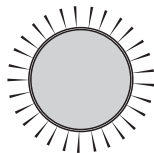

60S

OFF



ON

1

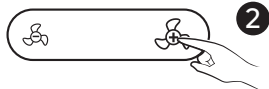

2

Vitesse/Velocidad/Velocidade/Velocità
/Ταχύτητα/Prędkość/Швидкість/Vitezà
/Snelheid/Geschwindigkeit/Speed

1-2-3-4-5-6



OFF

3



Mode brise / Modo brisa / Modo brisa / Modalità brezza /
 Λειτουργία αεράκι / Tryb bryza / Режим бризу / Modul brizá
 / Modo brisa / Briesmodus / Brisenmodus / Breeze mode

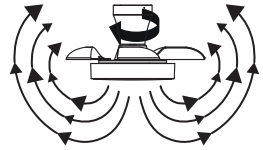

variation de la vitesse / variación de la velocidad / variação da velocidade / variazione della velocità / μεταβολή της ταχύτητας / zmiana prędkości /
 variația швидкості / variația vitezei / variação da velocidade / snelheidsvariatie / Geschwindigkeitsvariation / speed variation



Été/Hiver- Verano/Invierno -
 Verão/Inverno - Estate/Inverno -
 Καλοκαίρι/Χειμώνας - Lato/Zima -
 Літо/Зима - Arã/Iarnă - Zomer/Winter -
 Sommer/Winter - Summer/Winter

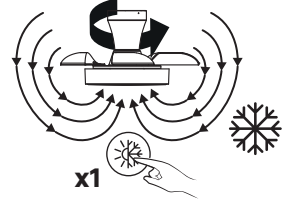
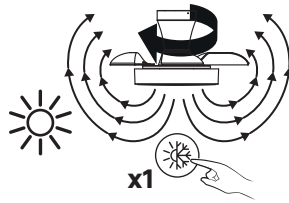

Minuterie/Temporizador/
 Χρονοδιακόπτης/Minutnik/
 Таймер/Chronometru/Timer



1h - 2h - 4h ▶ OFF

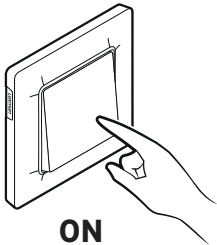
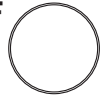

Avec le Ventilateur/Con el Ventilador/Com o Ventilador/Con il Ventilatore/Με τον Ανεμιστήρα/Z Wentylatorem/
 3 Вентилятором/Cu Ventilatorul/Met de Ventilator/Mit dem Ventilator/With the Ceiling Fan

2700K

4000K

6500K

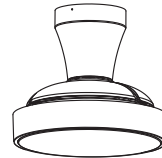
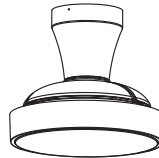

<3 sec



<3 sec



<3 sec



Made in China
Країна походження: Китай

EU - ADEO Services - 135 Rue Sadi Carnot - CS00001 - 59790 RONCHIN - FRANCE
www.product-regulatory.adeoservices.com

UA Виробник: ТОВ "Адео Сервісез С.А.", вул. Саді Карно, CS 00001, 59790 Роншен, Франція.
Імпортер, суб'єкт господарювання, що відповідає за виконання гарантійних зобов'язань: ТОВ "Леруа Мерлен Україна", 04201 Україна, м.Київ, вул. Полярна 17А, +380 44 498 46 00.

ZA Imported by Adeo South Africa (PTY) LTD T/A Leroy Merlin,
Hosted in Leroy Merlin Fourways Store 35 Roos Street, Witkoppen Ext 97, Sandton, 2191 Johannesburg, Gauteng, South Africa.
Tel: +27 10 493 8000 Email: contact@le-roymerlin.co.za.

BR LEROY MERLIN COMPANHIA BRASILEIRA DE BRICOLAGEM CNPJ:
01.438.784/0001-05
Rua Pascoal Pais, nº. 525, 6º andar cj 61 a 64, Vila Cordeiro, São Paulo -SP. CEP:
04581-060
CALM (Central de Atendimento Leroy Merlin) Capitais 4020-5376 Demais Regiões 0800-0205376



Points de collecte sur www.quefairedemesdechets.fr
Privilégiez la réparation ou le don de votre appareil !