

SERIAL NUMBER	NAME OF MATERIAL	NUMBER
1	Mounting bracket (metal)	1
2	Receiver	1
3	Remote controller	1
4	Motor	1
5	Plastic rear net	1
6	LED MODULE	1
7	Blade	1
8	Blade lock mechanism	1
9	Lamp shape	1
10	Blade gauze	1
11		1

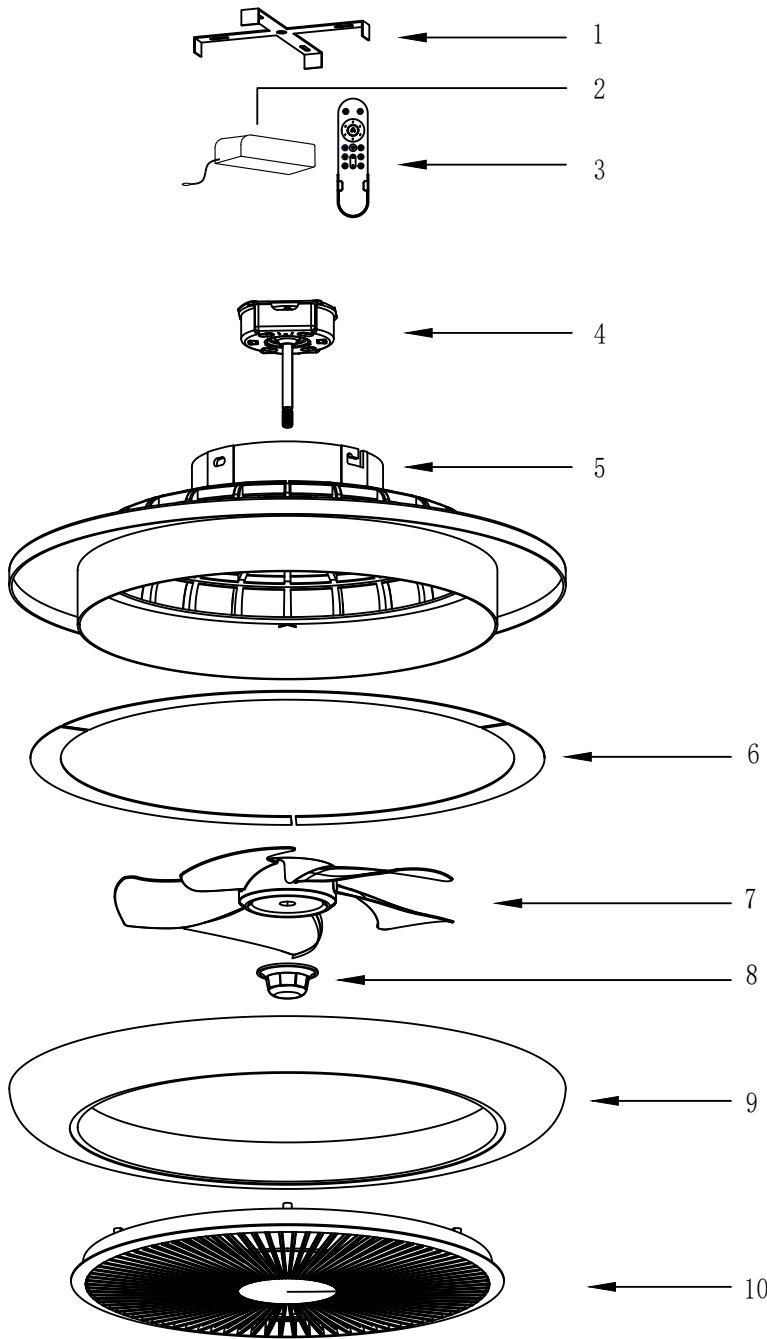

产品名称 ITEM	吊扇	产品型号 TYPE	TX-12DL02	图号 DWG. NO.	TX%%
零件名称 ITEM	爆炸图	材料 MATERIALS	%%	物料编码 MATE. NO.	
绘图 DRAW	卢俊安	绘制日期 DATE	2025/08/18	用量 QUANTITY	1
设计 DESIGNER		单位 UNIT	mm	比例 SCALE	1:1
审核 CHECK		视图 VIEW		江门市蓬江区德信电器有限公司	
批准 APPROVE		Techxin Electric Appliance Manufacture Co., Ltd			
标记 REV.	修改内容 MODIFICATION	修改人 BY	修改日期 DATE		