

DRAWER SLIDES

MODEL:4605S2

DRAWER SLIDES

MODEL:4605S2







Warning-To reduce the risk of injury, user must read instructions manual carefully.

WARNING:

1. Please assemble the product in strict accordance with the instructions. Incorrect assembly could be hazardous.
 2. Please wear safety goggles and work gloves properly during assembly.
 3. Do not try to assemble the product when feeling tired or when under the influence of alcohol, drugs, or medication.
 4. Load-bearing capacity and other product parameters are applied to the properly and completely assembled product only.
 5. Separate and count all parts and hardware.
 6. Prepare the following tool: Philips Head Screwdriver.
 7. If using power tools, please be careful to slow down and stop when needed.
 8. Two people are required for assembly.
 9. Follow the intended uses only.
- Save the instructions.

Product Introduction

Part List (pcs)		
Item		
Model	Slide	Screws
4605S2.350-10	10	120
4605S2.350-6	6	72
4605S2.400-10	10	120
4605S2.400-6	6	72
4605S2.450-10	10	120
4605S2.450-6	6	72

4605S2.500-10	10	120
4605S2.500-6	6	72
4605S2.550-10	10	120
4605S2.550-6	6	72
4605S2.600-10	10	120
4605S2.600-6	6	72

Model	Applicable Drawer Length (inch)	Sliding Length (mm)	Max. Load (kg / lbs)
4605S2.350-10	14	325	100 / 45.4
4605S2.350-6	14	325	
4605S2.400-10	16	400	
4605S2.400-6	16	400	
4605S2.450-10	18	450	
4605S2.450-6	18	450	
4605S2.500-10	20	500	
4605S2.500-6	20	500	
4605S2.550-10	22	550	
4605S2.550-6	22	550	
4605S2.600-10	24	600	
4605S2.600-6	24	600	

Installation Dimensions (mm)

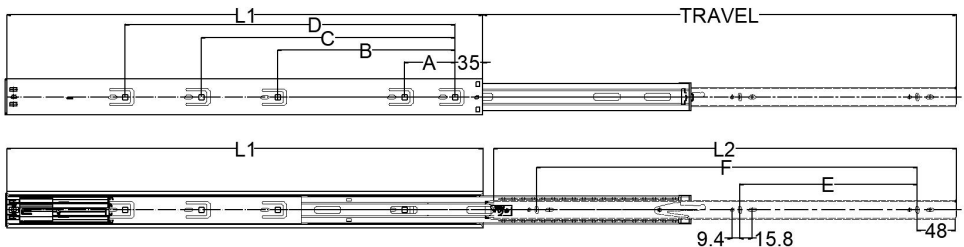

Model	Size (mm)		Travel (mm)	Hole Pattern (mm)					
	L1	L2		A	B	C	D	E	F

4605S2.350	350	332	325	64	192	/	/	128	241
4605S2.400	400	382	400	64	224	/	/	160	288
4605S2.450	450	432	450	64	224	288	/	160	320
4605S2.500	500	482	500	64	224	320	/	192	384
4605S2.550	550	532	550	64	224	384	/	192	416
4605S2.600	600	582	600	64	224	352	416	224	480

Installation Procedure

◆ Note the following two points during installation:

1. Pay attention to the installation space on both sides. (Units: mm)

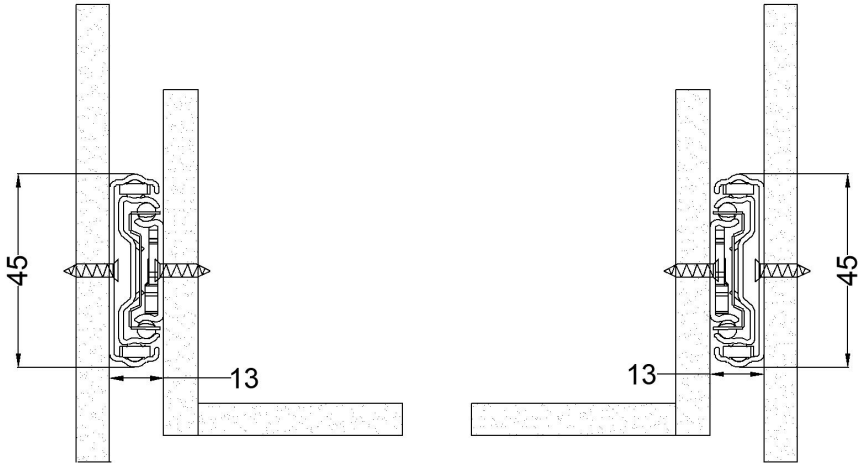

2. 2mm away from the front end of the cabinet. (Units: mm)

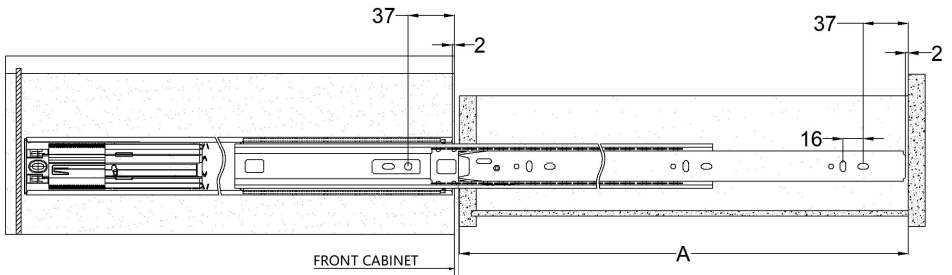

STEP1: Cabinet Installation For Ball Bearing

1. Install the steel ball rail to the inside of the cabinet according to the large

drawing of the screw.

2. The bead frame should be pushed flat with the file glue to facilitate the installation of the drawer.

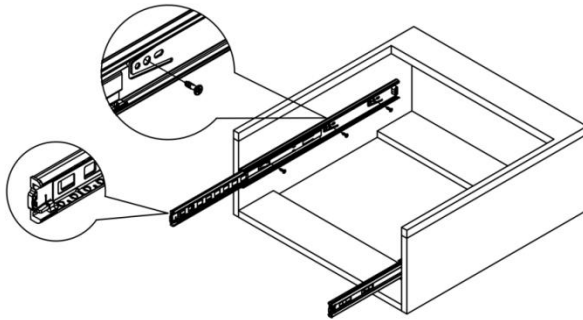

STEP2:Drawer Slide Installation

Screw the ball rail to the outside of the drawer as shown in the layout diagram.

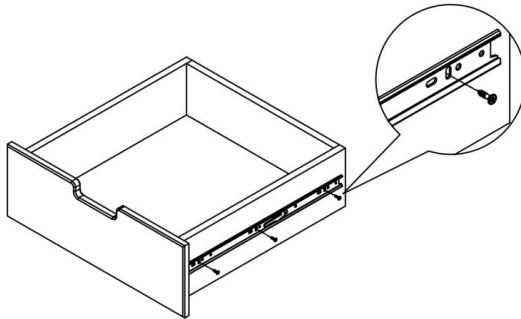

STEP3:Drawer Installation

On both sides of the inner rail to the upper middle rail file glue through the slot to install the drawer on.

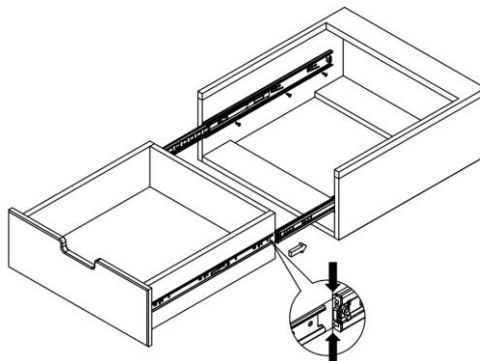

STEP4:Disassembl Drawer

When removing the drawer, pull the drawer out by using the fork in the enlarged image to pull it out completely.

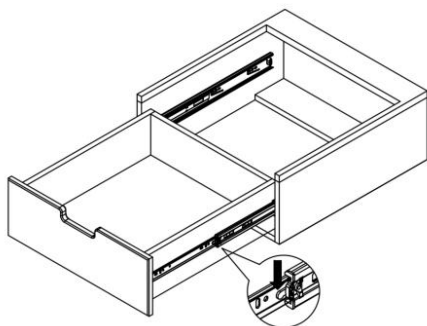

Address: Baoshanqu Shuangchenglu 803long 11hao 1602A-1609shi
Shanghai

Imported to AUS: SIHAO PTY LTD. 1 ROKEVA STREETEASTWOOD
NSW 2122 Australia

Imported to USA: Sanven Technology Ltd.Suite 250, 9166 Anaheim Place,
Rancho Cucamonga, CA 91730



Pooledas Group Ltd
Unit 5 Albert Edward House, The Pavilions
Preston, United Kingdom



SHUNSHUN GmbH
Römeräcker 9 Z2021, 76351
Linkenheim-Hochstetten, Germany

Made In China

GLISSIÈRES DE TIROIR

MODÈLE:4605S2

DRAWER SLIDES

MODÈLE:4605S2







Avertissement : Pour réduire le risque de blessure, l'utilisateur doit lire attentivement le manuel d'instructions.

AVERTISSEMENT:

1. Veuillez assembler le produit en stricte conformité avec les instructions. Un assemblage incorrect pourrait être dangereux.
 2. Veuillez porter correctement des lunettes de sécurité et des gants de travail pendant l'assemblage.
 3. N'essayez pas d'assembler le produit lorsque vous vous sentez fatigué ou sous l'influence de l'alcool, de drogues ou de médicaments.
 4. La capacité de charge et les autres paramètres du produit sont appliqués uniquement au produit correctement et complètement assemblé.
 5. Séparez et comptez toutes les pièces et le matériel.
 6. Préparez l'outil suivant : Tournevis cruciforme.
 7. Si vous utilisez des outils électriques, veillez à ralentir et à vous arrêter si nécessaire.
 8. Deux personnes sont nécessaires pour le montage.
 9. Suivez uniquement les utilisations prévues.
- Enregistrez les instructions.

Présentation du produit

Liste des pièces (pièces)		
Article		
Modèle	Glisser	Des vis
4605S2.350-10	dix	120
4605S2.350-6	6	72
4605S2.400-10	dix	120
4605S2.400-6	6	72
4605S2.450-10	dix	120

4605S2.450-6	6	72
4605S2.500-10	dix	120
4605S2.500-6	6	72
4605S2.550-10	dix	120
4605S2.550-6	6	72
4605S2.600-10	dix	120
4605S2.600-6	6	72

Modèle	Longueur de tiroir applicable (pouces)	Longueur coulissante (mm)	Max. Charger (kg/livres)
4605S2.350-10	14	325	100 / 45,4
4605S2.350-6	14	325	
4605S2.400-10	16	400	
4605S2.400-6	16	400	
4605S2.450-10	18	450	
4605S2.450-6	18	450	
4605S2.500-10	20	500	
4605S2.500-6	20	500	
4605S2.550-10	22	550	
4605S2.550-6	22	550	
4605S2.600-10	24	600	
4605S2.600-6	24	600	

Dimensions d'installation (mm)

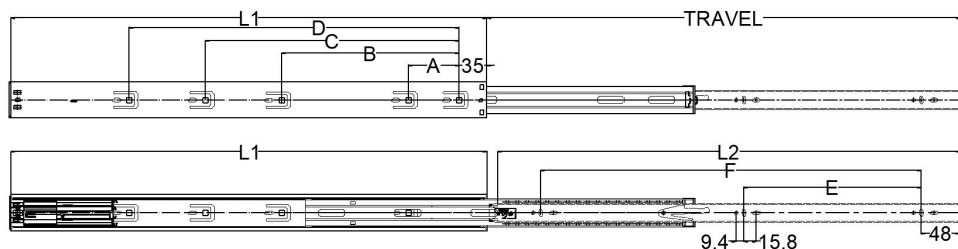

Modèle	Taille (mm)		Voyage (mm)	Modèle de trou (mm)					
	L1	L2		U N	B	C	D	E	F
4605S2.350	350	332	325	64	192	/	/	128	241
4605S2.400	400	382	400	64	224	/	/	160	288
4605S2.450	450	432	450	64	224	288	/	160	320
4605S2.500	500	482	500	64	224	320	/	192	384
4605S2.550	550	532	550	64	224	384	/	192	416
4605S2.600	600	582	600	64	224	352	416	224	480

P rocédure d'installation

◆ Notez les deux points suivants lors de l'installation :

1. Faites attention à l'espace d'installation des deux côtés. (Unités : mm)

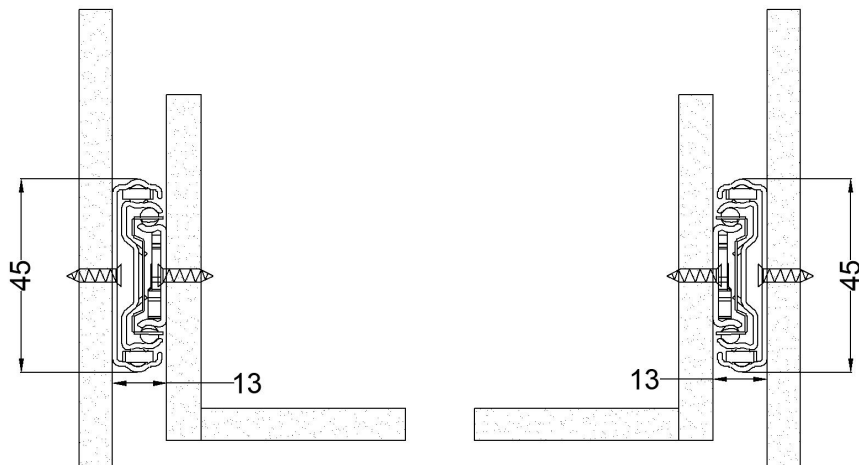

À 2,2 mm de l'extrémité avant de l'armoire. (Unités: mm)

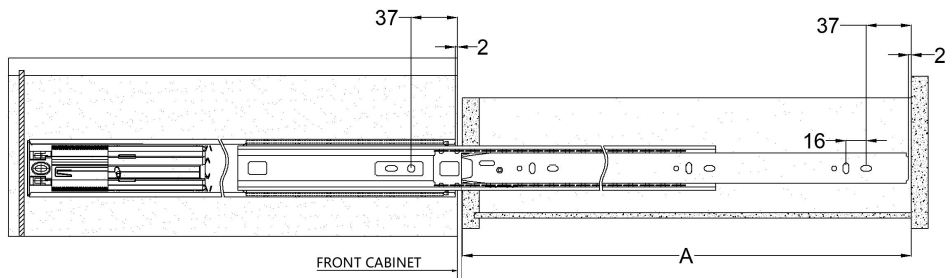

1 : Installation de l'armoire pour le roulement à billes

3. Installez le rail à billes en acier à l'intérieur de l'armoire selon le grand dessin de la vis .

4. Le cadre en perles doit être poussé à plat avec la colle à lime pour faciliter l'installation du tiroir.

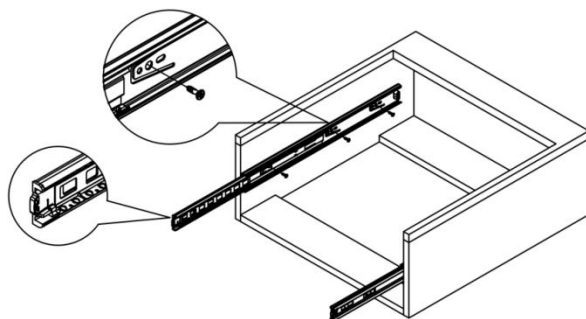

ÉTAPE 2 : Installation de la glissière du tiroir

Vissez le rail à billes à l'extérieur du tiroir comme indiqué sur le schéma d'implantation.

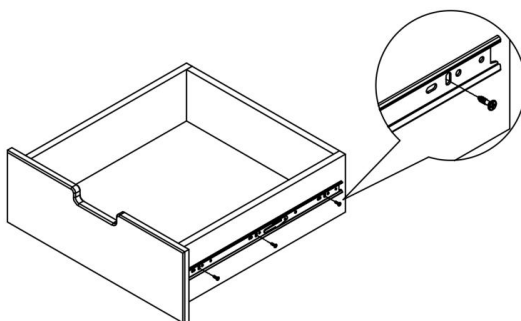

ÉTAPE 3 : Installation du tiroir

Des deux côtés du rail intérieur, collez le rail central supérieur à travers la

fente pour installer le tiroir.

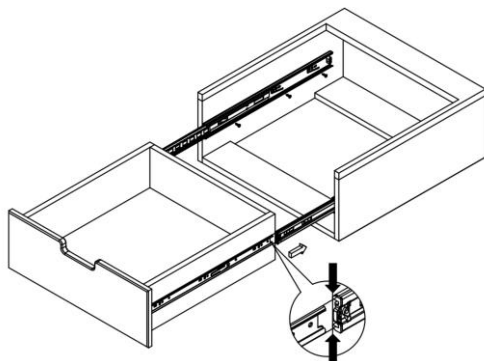

ÉTAPE 4 : Démonter le tiroir

Lorsque vous retirez le tiroir, retirez-le en utilisant la fourchette sur l'image agrandie pour le retirer complètement.

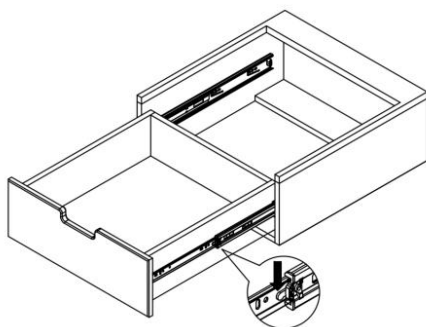

Adresse : Baoshanqu Shuangchenglu 803long 11hao 1602A-1609shi
Shanghai

Importé en Australie : SIHAO PTY LTD . 1 ROKEVA STREETASTWOOD
NSW 2122 Australie

Importé aux États-Unis : Sanven Technology Ltd. Bureau 250, 9166
Anaheim Place, Rancho Cucamonga, CA 91730

UK	REP
-----------	------------

Pooledas Group Ltd
Unit 5 Albert Edward House, The Pavilions
Preston, United Kingdom

EC	REP
-----------	------------

SHUNSHUN GmbH
Römeräcker 9 Z2021, 76351
Linkenheim-Hochstetten, Germany

Fabriqué en Chine

SCHUBLADENFÜHRUNGEN

MODELL: 4605S2

DRAWER SLIDES

MODELL: 4605S2







Warnung: Um das Verletzungsrisiko zu verringern, muss der Benutzer die Bedienungsanleitung sorgfältig lesen.

WARNUNG:

1. Bitte bauen Sie das Produkt unter strikter Einhaltung der Anweisungen zusammen. Eine falsche Montage kann gefährlich sein.
2. Bitte tragen Sie bei der Montage ordnungsgemäß eine Schutzbrille und Arbeitshandschuhe.
3. Versuchen Sie nicht, das Produkt zusammenzubauen, wenn Sie sich müde fühlen oder unter dem Einfluss von Alkohol, Drogen oder Medikamenten stehen.
4. Tragfähigkeit und sonstige Produktparameter beziehen sich ausschließlich auf das ordnungsgemäß und vollständig montierte Produkt.
5. Trennen und zählen Sie alle Teile und Hardware.
6. Bereiten Sie das folgende Werkzeug vor: Kreuzschlitzschraubendreher.
7. Wenn Sie Elektrowerkzeuge verwenden, achten Sie bitte darauf, langsamer zu fahren und bei Bedarf anzuhalten.
8. Für den Aufbau sind zwei Personen erforderlich.
9. Befolgen Sie nur die vorgesehenen Verwendungszwecke.
Bewahren Sie die Anweisungen auf.

Produkteinführung

Teilleiste (Stück)		
Artikel		
Modell	Gleiten	Schrauben
4605S2.350-10	10	120
4605S2.350-6	6	72
4605S2.400-10	10	120
4605S2.400-6	6	72

4605S2.450-10	10	120
4605S2.450-6	6	72
4605S2.500-10	10	120
4605S2.500-6	6	72
4605S2.550-10	10	120
4605S2.550-6	6	72
4605S2.600-10	10	120
4605S2.600-6	6	72

Modell	Anwendbare Schubladenlänge (Zoll)	Gleitlänge (mm)	Max. Belastung (kg / lbs)
4605S2.350-10	14	325	100 / 45,4
4605S2.350-6	14	325	
4605S2.400-10	16	400	
4605S2.400-6	16	400	
4605S2.450-10	18	450	
4605S2.450-6	18	450	
4605S2.500-10	20	500	
4605S2.500-6	20	500	
4605S2.550-10	22	550	
4605S2.550-6	22	550	
4605S2.600-10	24	600	
4605S2.600-6	24	600	

Einbaumaße (mm)

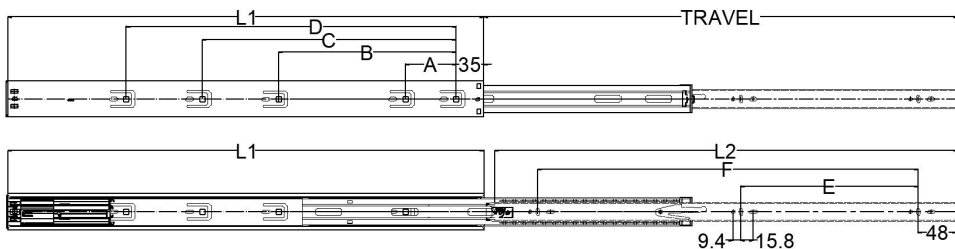

Modell	Größe (mm)		Federweg (mm)	Lochmuster (mm)					
	L1	L2		A	B	C	D	E	F
4605S2.350	350	332	325	64	192	/	/	128	241
4605S2.400	400	382	400	64	224	/	/	160	288
4605S2.450	450	432	450	64	224	288	/	160	320
4605S2.500	500	482	500	64	224	320	/	192	384
4605S2.550	550	532	550	64	224	384	/	192	416
4605S2.600	600	582	600	64	224	352	416	224	480

Installationsvorgang _ _

◆ **Beachten Sie bei der Installation die folgenden zwei**

Punkte :

1. Achten Sie auf den Installationsraum auf beiden Seiten. (Einheiten: mm)

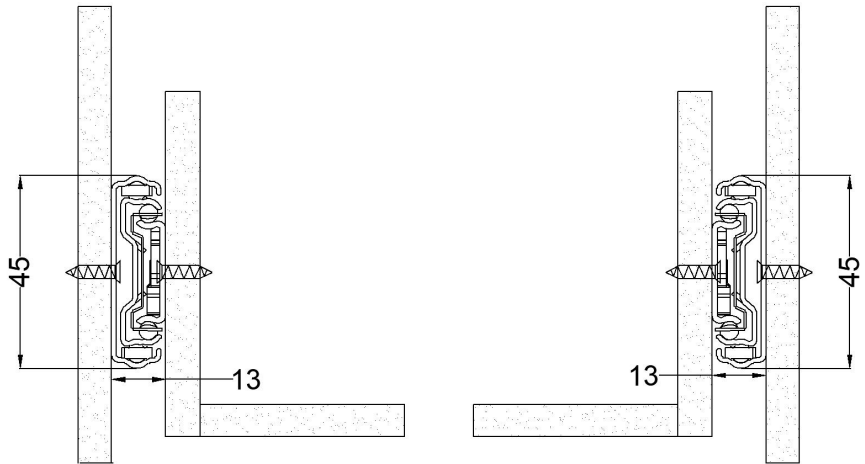

2,2 mm vom vorderen Ende des Gehäuses entfernt. (Einheiten: mm)

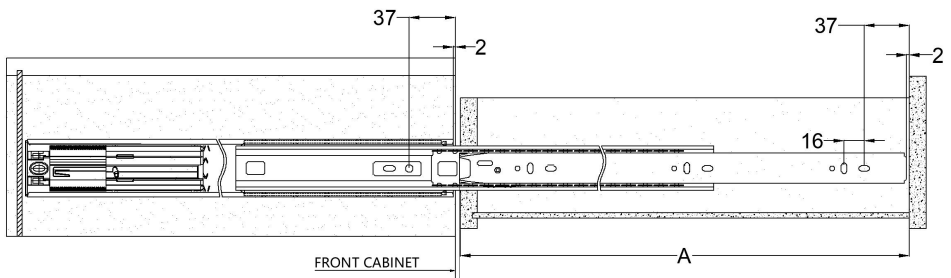

SCHRITT 1 : Schrankinstallation für alle B - Lager _

5. Montieren Sie die Stahlkugelschiene gemäß der großen Zeichnung der Schraube an der Innenseite des Schanks .

6. Der Sickenrahmen sollte mit dem Feilenkleber flach gedrückt werden, um den Einbau der Schublade zu erleichtern.

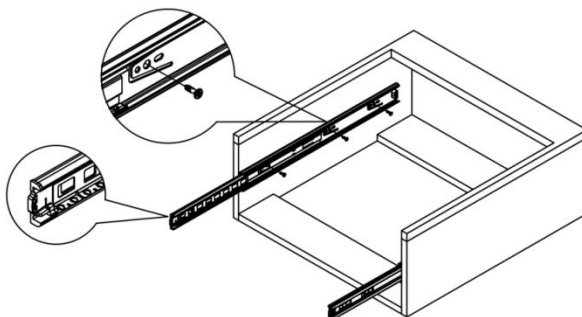

SCHRITT 2: Installation der Schubladenführung

Schrauben Sie die Kugelschiene wie im Aufbauplan dargestellt an der Außenseite der Schublade fest.

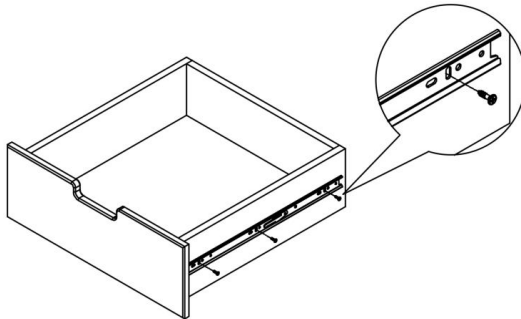

SCHRITT 3: Schubladeninstallation

Feilen Sie auf beiden Seiten der Innenschiene bis zur oberen Mittelschiene Kleber durch den Schlitz, um die Schublade darin zu installieren.

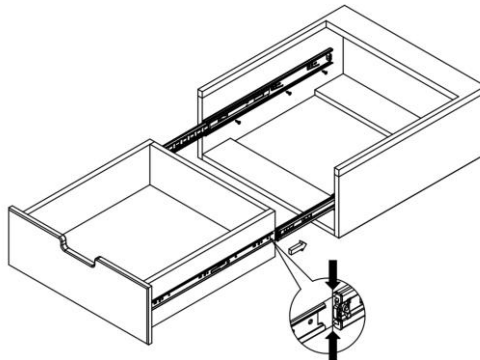

SCHRITT 4: Schublade demontieren

Wenn Sie die Schublade herausnehmen, ziehen Sie sie mit der Gabel im vergrößerten Bild heraus, um sie vollständig herauszuziehen.

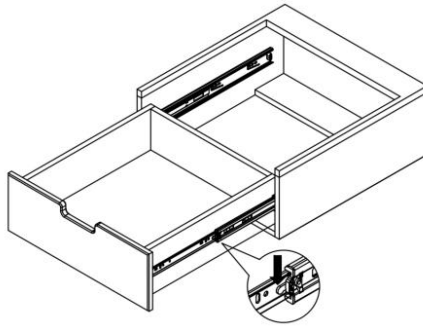

Adresse: Baoshanqu Shuangchenglu 803long 11hao 1602A-1609shi
Shanghai

Importiert nach AUS: SIHAO PTY LTD . 1 ROKEVA
STREETEASTWOOD NSW 2122 Australien

Importiert in die USA: Sanven Technology Ltd. Suite 250, 9166 Anaheim
Place, Rancho Cucamonga, CA 91730



Pooledas Group Ltd
Unit 5 Albert Edward House, The Pavilions
Preston, United Kingdom



SHUNSHUN GmbH
Römeräcker 9 Z2021, 76351
Linkenheim-Hochstetten, Germany

In China hergestellt

GUIDE PER CASSETTI

MODELLO:4605S2

DRAWER SLIDES

MODELLO:4605S2







Avvertenza: per ridurre il rischio di lesioni, l'utente deve leggere attentamente il manuale di istruzioni.

AVVERTIMENTO:

1. Si prega di assemblare il prodotto attenendosi rigorosamente alle istruzioni. Un montaggio errato potrebbe essere pericoloso.
 2. Indossare correttamente occhiali protettivi e guanti da lavoro durante il montaggio.
 3. Non tentare di montare il prodotto quando ci si sente stanchi o sotto l'influenza di alcol, droghe o farmaci.
 4. La capacità di carico e altri parametri del prodotto si applicano solo al prodotto correttamente e completamente assemblato.
 5. Separare e contare tutte le parti e l'hardware.
 6. Preparare il seguente strumento: cacciavite a croce.
 7. Se si utilizzano utensili elettrici, fare attenzione a rallentare e fermarsi quando necessario.
 8. Per il montaggio sono necessarie due persone.
 9. Seguire solo gli usi previsti.
- Salva le istruzioni.

introduzione al prodotto

Elenco delle parti (pezzi)		
Articolo		
Modello	Diapositiva	Viti
4605S2.350-10	10	120
4605S2.350-6	6	72
4605S2.400-10	10	120
4605S2.400-6	6	72
4605S2.450-10	10	120

4605S2.450-6	6	72
4605S2.500-10	10	120
4605S2.500-6	6	72
4605S2.550-10	10	120
4605S2.550-6	6	72
4605S2.600-10	10	120
4605S2.600-6	6	72

Modello	Lunghezza cassetto applicabile (pollici)	Lunghezza scorrevole (mm)	Massimo. Carico (kg/libbre)
4605S2.350-10	14	325	100/45.4
4605S2.350-6	14	325	
4605S2.400-10	16	400	
4605S2.400-6	16	400	
4605S2.450-10	18	450	
4605S2.450-6	18	450	
4605S2.500-10	20	500	
4605S2.500-6	20	500	
4605S2.550-10	22	550	
4605S2.550-6	22	550	
4605S2.600-10	24	600	
4605S2.600-6	24	600	

Dimensioni di installazione (mm)

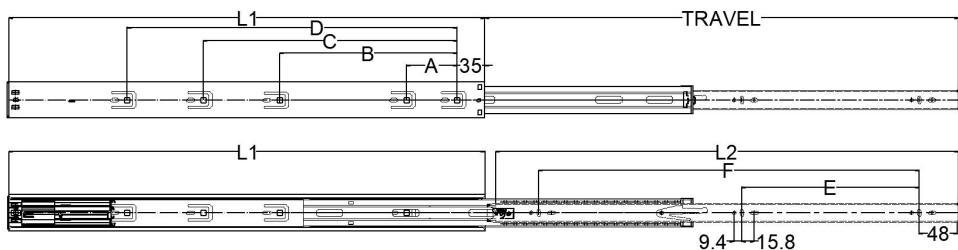

Modello	Dimensioni (mm)		Corsa (mm)	Schema fori (mm)					
	L1	L2		U N	B	C	D	E	F
4605S2.350	350	332	325	64	192	/	/	128	241
4605S2.400	400	382	400	64	224	/	/	160	288
4605S2.450	450	432	450	64	224	288	/	160	320
4605S2.500	500	482	500	64	224	320	/	192	384
4605S2.550	550	532	550	64	224	384	/	192	416
4605S2.600	600	582	600	64	224	352	416	224	480

Procedura di installazione

◆ Notare i seguenti due punti durante l'installazione :

1. Prestare attenzione allo spazio di installazione su entrambi i lati.
(Unità:mm)

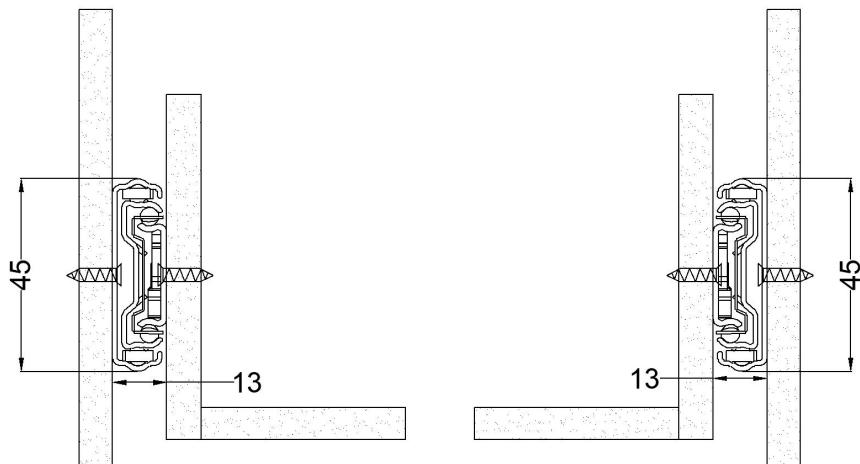

2,2 mm di distanza dall'estremità anteriore del mobile. (Unità: mm)

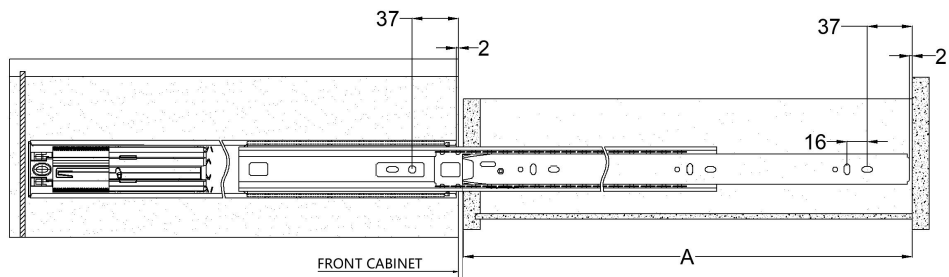

PASSO 1: Installazione del mobile F o B con tutti i cuscinetti

7. Installare la guida a sfera in acciaio all'interno dell'armadio secondo il grande disegno della vite .

8. Il telaio del tallone deve essere piatto con la colla per lima per facilitare l'installazione del cassetto.

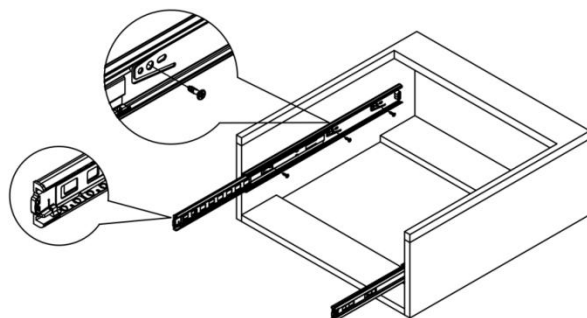

PASSO 2: Installazione della guida del cassetto

Avvitare la guida a sfera all'esterno del cassetto come mostrato nello schema di disposizione.

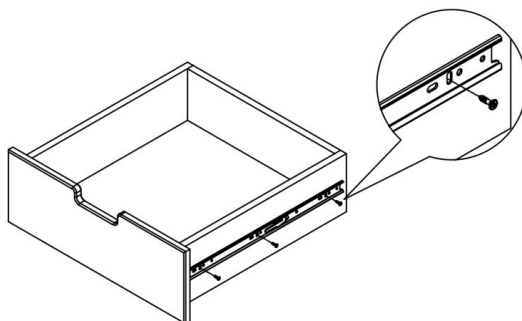

PASSO 3: Installazione del cassetto

Su entrambi i lati del binario interno fino al binario centrale superiore, incollare la colla attraverso la fessura per installare il cassetto.

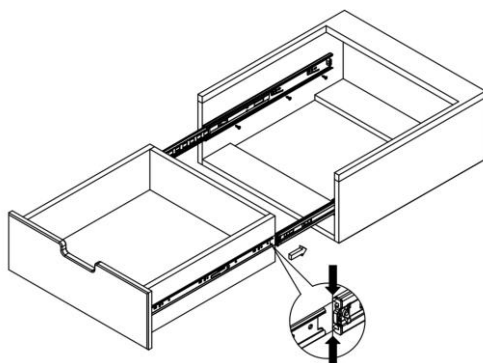

PASSO 4: smontare il cassetto

Quando si rimuove il cassetto, estrarre il cassetto utilizzando la forchetta nell'immagine ingrandita per estrarlo completamente.

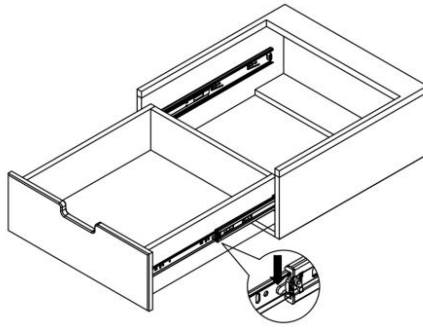

Indirizzo: Baoshanqu Shuangchenglu 803long 11hao 1602A-1609shi
Shanghai

Importato in AUS: SIHAO PTY LTD . 1 ROKEVA STREETEASTWOOD
NSW 2122 Australia

Importato negli Stati Uniti: Sanven Technology Ltd. Suite 250, 9166
Anaheim Place, Rancho Cucamonga, CA 91730

UK	REP
-----------	------------

Pooledas Group Ltd
Unit 5 Albert Edward House, The Pavilions
Preston, United Kingdom

EC	REP
-----------	------------

SHUNSHUN GmbH
Römeräcker 9 Z2021, 76351
Linkenheim-Hochstetten, Germany

Made in China

GUÍAS PARA CAJONES

MODELO: 4605S2

DRAWER SLIDES

MODELO: 4605S2







Advertencia: para reducir el riesgo de lesiones, el usuario debe leer atentamente el manual de instrucciones.

ADVERTENCIA:

1. Ensamble el producto estrictamente de acuerdo con las instrucciones. El montaje incorrecto podría ser peligroso.
 2. Utilice gafas de seguridad y guantes de trabajo correctamente durante el montaje.
 3. No intente montar el producto cuando se sienta cansado o bajo la influencia del alcohol, drogas o medicamentos.
 4. La capacidad de carga y otros parámetros del producto se aplican únicamente al producto ensamblado de manera adecuada y completa.
 5. Separe y cuente todas las piezas y herrajes.
 6. Prepare la siguiente herramienta: Destornillador Philips.
 7. Si utiliza herramientas eléctricas, tenga cuidado de reducir la velocidad y detenerse cuando sea necesario.
 8. Para el montaje se necesitan dos personas.
 9. Siga únicamente los usos previstos.
- Guarde las instrucciones.

Introducción del producto

Lista de piezas (piezas)		
Artículo	 Deslizar	 Tornillos
4605S2.350-10	10	120
4605S2.350-6	6	72
4605S2.400-10	10	120
4605S2.400-6	6	72
4605S2.450-10	10	120

4605S2.450-6	6	72
4605S2.500-10	10	120
4605S2.500-6	6	72
4605S2.550-10	10	120
4605S2.550-6	6	72
4605S2.600-10	10	120
4605S2.600-6	6	72

Modelo	Longitud de cajón aplicable (pulgadas)	Longitud de deslizamiento (mm)	Máx. Carga (kg/libras)
4605S2.350-10	14	325	100 / 45,4
4605S2.350-6	14	325	
4605S2.400-10	dieciséis	400	
4605S2.400-6	dieciséis	400	
4605S2.450-10	18	450	
4605S2.450-6	18	450	
4605S2.500-10	20	500	
4605S2.500-6	20	500	
4605S2.550-10	22	550	
4605S2.550-6	22	550	
4605S2.600-10	24	600	
4605S2.600-6	24	600	

Dimensiones de instalación (mm)

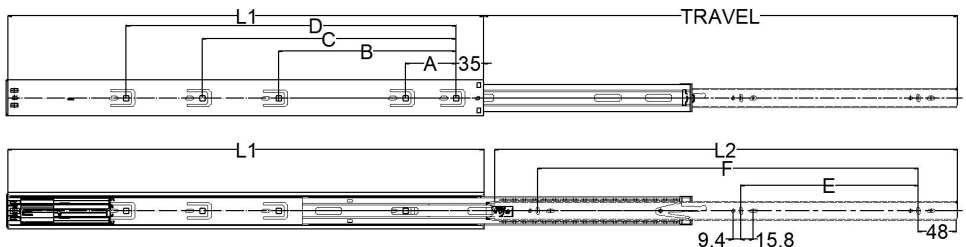

Modelo	Tamaño (mm)		Recorrido (mm)	Patrón de agujeros (mm)					
	L1	L2		A	B	C	D	mi	F
4605S2.350	350	332	325	64	192	/	/	128	241
4605S2.400	400	382	400	64	224	/	/	160	288
4605S2.450	450	432	450	64	224	288	/	160	320
4605S2.500	500	482	500	64	224	320	/	192	384
4605S2.550	550	532	550	64	224	384	/	192	416
4605S2.600	600	582	600	64	224	352	416	224	480

Procedimiento de instalación

◆ Tenga en cuenta los dos puntos siguientes durante la instalación :

1. Preste atención al espacio de instalación en ambos lados. (Unidades: mm)

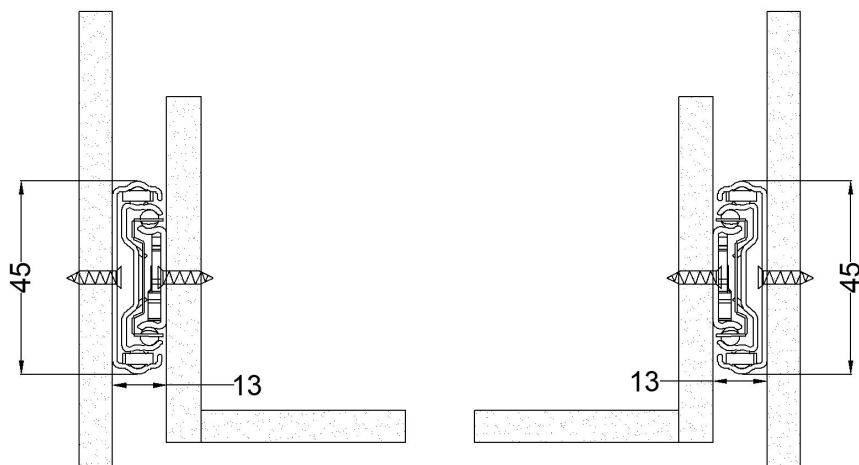

A 2,2 mm del extremo frontal del gabinete. (Unidades: mm)

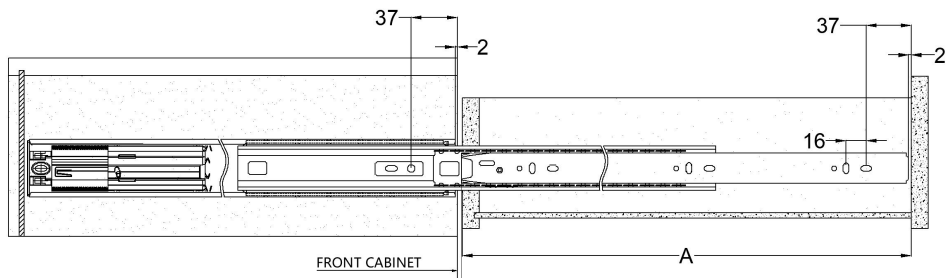

PASO 1 : Instalación del gabinete para todos los rodamientos

9. Instale el riel de bolas de acero en el interior del gabinete de acuerdo con el dibujo grande del tornillo .

10. El marco de cuentas debe quedar plano con pegamento para limas para facilitar la instalación del cajón.

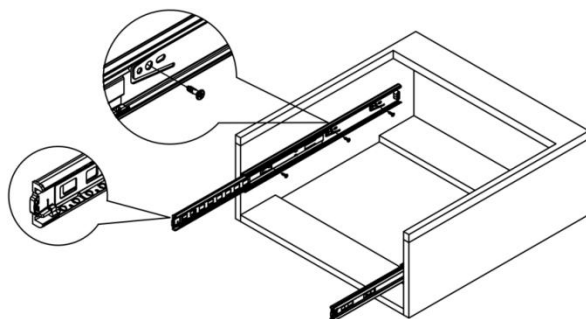

PASO 2: Instalación de correderas para cajones

Atornille el riel de bolas al exterior del cajón como se muestra en el diagrama de distribución.

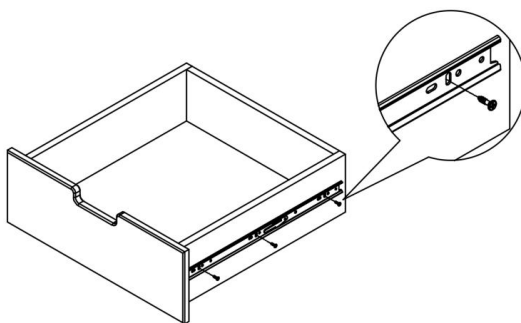

PASO 3: Instalación del cajón

En ambos lados del riel interior hasta el riel medio superior, pegue el

pegamento a través de la ranura para instalar el cajón.

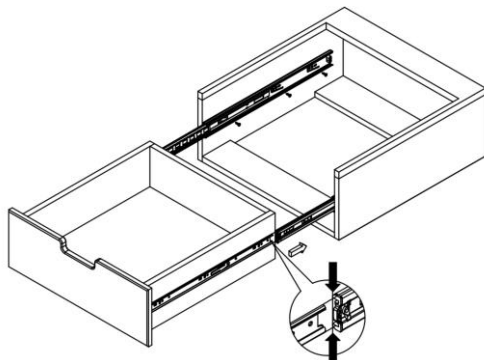

PASO 4: Desmontar el cajón

Al retirar el cajón, sáquelo utilizando el tenedor en la imagen ampliada para sacarlo por completo.

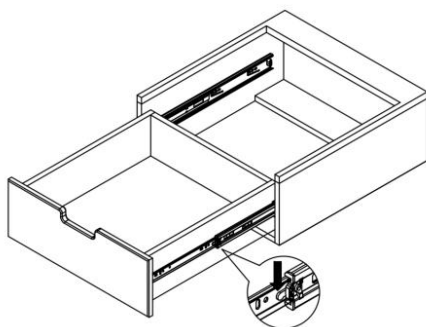

Dirección: Baoshanqu Shuangchenglu 803long 11hao 1602A-1609shi
Shanghai

Importado a AUS: SIHAO PTY LTD . 1 ROKEVA STREET ASTWOOD
NSW 2122 Australia

Importado a EE. UU.: Sanven Technology Ltd. Suite 250, 9166 Anaheim
Place, Rancho Cucamonga, CA 91730

UK	REP
-----------	------------

Pooledas Group Ltd
Unit 5 Albert Edward House, The Pavilions
Preston, United Kingdom

EC	REP
-----------	------------

SHUNSHUN GmbH
Römeräcker 9 Z2021, 76351
Linkenheim-Hochstetten, Germany

Hecho en china

PROWADNICE SZUFLAD

MODEL: 4605S2

DRAWER SLIDES

MODEL: 4605S2







Ostrzeżenie — aby zmniejszyć ryzyko obrażeń, użytkownik musi uważnie przeczytać instrukcję obsługi.

OSTRZEŻENIE:

1. Prosimy o złożenie produktu ściśle według instrukcji. Nieprawidłowy montaż może być niebezpieczny.
 2. Podczas montażu należy nosić okulary ochronne i rękawice robocze.
 3. Nie próbuj składać produktu będąc zmęczonym lub będąc pod wpływem alkoholu, narkotyków lub leków.
 4. Nośność i inne parametry produktu odnoszą się wyłącznie do produktu prawidłowo i całkowicie zmontowanego.
 5. Oddziel i policz wszystkie części i osprzęt.
 6. Przygotuj następujące narzędzie: Śrubokręt Philips.
 7. Jeśli korzystasz z elektronarzędzi, pamiętaj, aby zwolnić i zatrzymać się, jeśli zajdzie taka potrzeba.
 8. Do montażu potrzebne są dwie osoby.
 9. Postępuj zgodnie z przeznaczeniem.
- Zapisz instrukcje.

Wprowadzenie produktów

Lista części (szt.)		
Przedmiot		
Model	Slajd	Śruby
4605S2.350-10	10	120
4605S2.350-6	6	72
4605S2.400-10	10	120
4605S2.400-6	6	72
4605S2.450-10	10	120
4605S2.450-6	6	72

4605S2.500-10	10	120
4605S2.500-6	6	72
4605S2.550-10	10	120
4605S2.550-6	6	72
4605S2.600-10	10	120
4605S2.600-6	6	72

Model	Odpowiednia długość szuflady (cale)	Długość przesuwna (mm)	Maks. Obciążenie (kg / funty)
4605S2.350-10	14	325	100 / 45,4
4605S2.350-6	14	325	
4605S2.400-10	16	400	
4605S2.400-6	16	400	
4605S2.450-10	18	450	
4605S2.450-6	18	450	
4605S2.500-10	20	500	
4605S2.500-6	20	500	
4605S2.550-10	22	550	
4605S2.550-6	22	550	
4605S2.600-10	24	600	
4605S2.600-6	24	600	

Wymiary montażowe (mm)

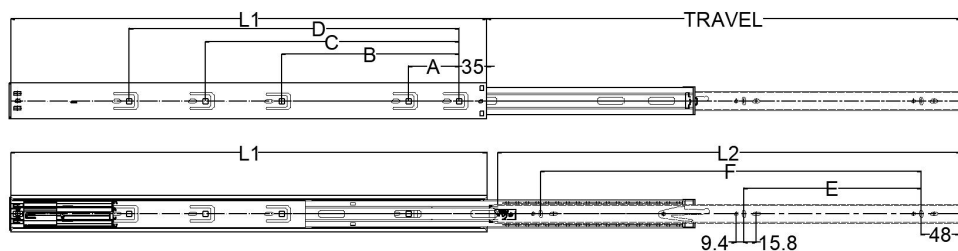

Model	Rozmiar (mm)		Skok (mm)	Wzór otworów (mm)					
	L1	L2		A	B	C	D	mi	F
4605S2.350	350	332	325	64	192	/	/	128	241
4605S2.400	400	382	400	64	224	/	/	160	288
4605S2.450	450	432	450	64	224	288	/	160	320
4605S2.500	500	482	500	64	224	320	/	192	384
4605S2.550	550	532	550	64	224	384	/	192	416
4605S2.600	600	582	600	64	224	352	416	224	480

Procedura instalacji _

◆ Podczas instalacji zwróć uwagę na następujące dwa punkty :

1. Zwróć uwagę na przestrzeń montażową po obu stronach. (Jednostki: mm)

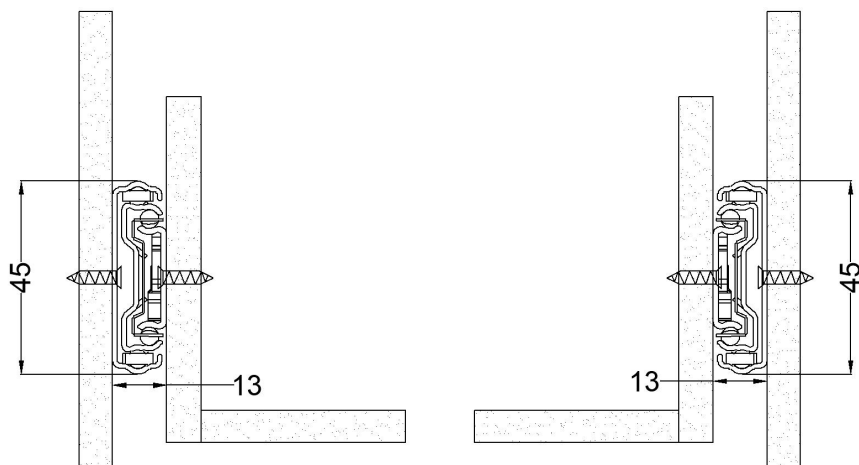

2,2 mm od przodu obudowy. (Jednostki: mm)

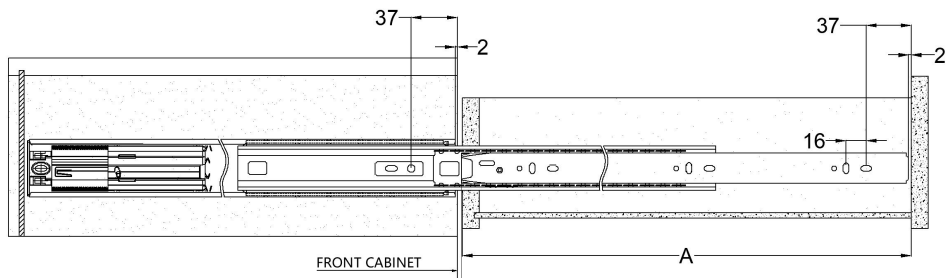

KROK 1: Montaż szafki F lub B , wszystkie łożyska

11. Zamontuj stalową szynę kulkową wewnątrz szafy zgodnie z dużym rysunkiem śruby .

12. Ramkę listwy należy docisnąć na płasko za pomocą kleju do pilników, aby ułatwić montaż szuflady.

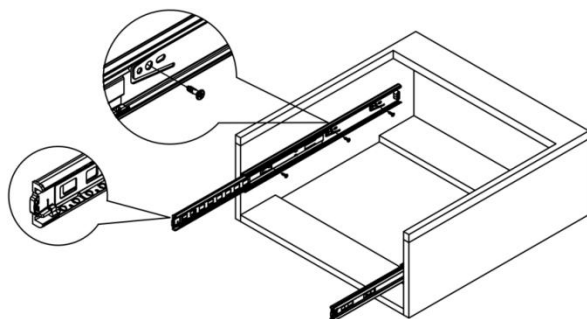

KROK 2: Instalacja prowadnicy szuflady

Przykręć szynę kulkową do zewnętrznej strony szuflady, jak pokazano na schemacie rozmieszczenia.

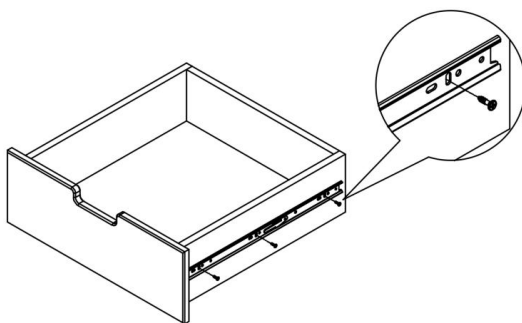

KROK 3: Instalacja szuflady

Po obu stronach wewnętrznej szyny do górnej środkowej szyny przyklej

plik przez szczelinę, aby zainstalować szufladę.

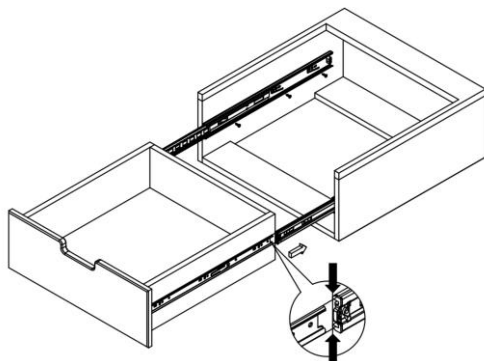

KROK 4: Zdemontuj szufladę

Wyjmując szufladę, wyciągnij ją całkowicie za pomocą widełek pokazanych na powiększonym obrazie.

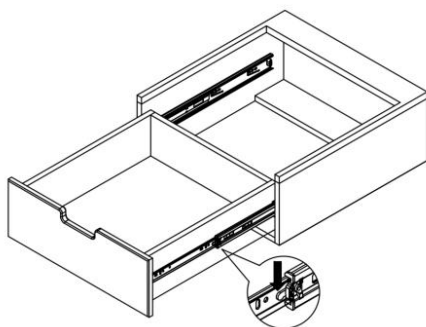

Adres: Baoshanqu Shuangchenglu 803long 11hao 1602A-1609shi
Szanghaj

Import do AUS: SIHAO PTY LTD . 1 ROKEVA STREETEASTWOOD
NSW 2122 Australia

Import do USA: Sanven Technology Ltd. Apartament 250, 9166 Anaheim
Place, Rancho Cucamonga, Kalifornia 91730

UK	REP
-----------	------------

Pooledas Group Ltd
Unit 5 Albert Edward House, The Pavilions
Preston, United Kingdom

EC	REP
-----------	------------

SHUNSHUN GmbH
Römeräcker 9 Z2021, 76351
Linkenheim-Hochstetten, Germany

Wyprodukowano w Chinach

LADEGELEIDERS

MODEL:4605S2

DRAWER SLIDES

MODEL:4605S2







Waarschuwing-Om het risico op letsel te verminderen, moet de gebruiker de handleiding zorgvuldig lezen.

WAARSCHUWING:

1. Monteer het product strikt volgens de instructies. Een onjuiste montage kan gevaarlijk zijn.
 2. Draag tijdens de montage een veiligheidsbril en werkhandschoenen.
 3. Probeer het product niet in elkaar te zetten als u zich moe voelt of onder invloed bent van alcohol, drugs of medicijnen.
 4. Draagvermogen en andere productparameters gelden alleen voor het correct en compleet gemonteerde product.
 5. Scheid en tel alle onderdelen en hardware.
 6. Houd het volgende gereedschap gereed: kruiskopschroevendraaier.
 7. Als u elektrisch gereedschap gebruikt, zorg er dan voor dat u langzamer gaat rijden en stopt wanneer dat nodig is.
 8. Voor de montage zijn twee personen nodig.
 9. Volg uitsluitend het beoogde gebruik.
- Bewaar de instructies.

product Introductie

Onderdelenlijst (stuks)		
Item		
Model	Dia	Schroeven
4605S2.350-10	10	120
4605S2.350-6	6	72
4605S2.400-10	10	120
4605S2.400-6	6	72
4605S2.450-10	10	120
4605S2.450-6	6	72

4605S2.500-10	10	120
4605S2.500-6	6	72
4605S2.550-10	10	120
4605S2.550-6	6	72
4605S2.600-10	10	120
4605S2.600-6	6	72

Model	Toepasselijke ladelengte (duim)	Glijdende lengte (mm)	Max. Laden (kg / lbs)
4605S2.350-10	14	325	100 / 45,4
4605S2.350-6	14	325	
4605S2.400-10	16	400	
4605S2.400-6	16	400	
4605S2.450-10	18	450	
4605S2.450-6	18	450	
4605S2.500-10	20	500	
4605S2.500-6	20	500	
4605S2.550-10	22	550	
4605S2.550-6	22	550	
4605S2.600-10	24	600	
4605S2.600-6	24	600	

Installatieafmetingen (mm)

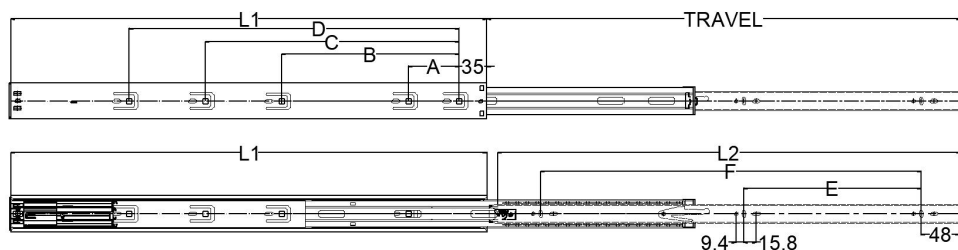

Model	Grootte	Reis	Gatenpatroon (mm)
-------	---------	------	-------------------

	(mm)		(mm)	(mm)					
	L1	L2		A	B	C	D	E	F
4605S2.350	350	332	325	64	192	/	/	128	241
4605S2.400	400	382	400	64	224	/	/	160	288
4605S2.450	450	432	450	64	224	288	/	160	320
4605S2.500	500	482	500	64	224	320	/	192	384
4605S2.550	550	532	550	64	224	384	/	192	416
4605S2.600	600	582	600	64	224	352	416	224	480

Installatieprocedure _ _

◆ **Let tijdens de installatie op de volgende twee punten :**

1. Let op de installatieruimte aan beide zijden. (Eenheden: mm)

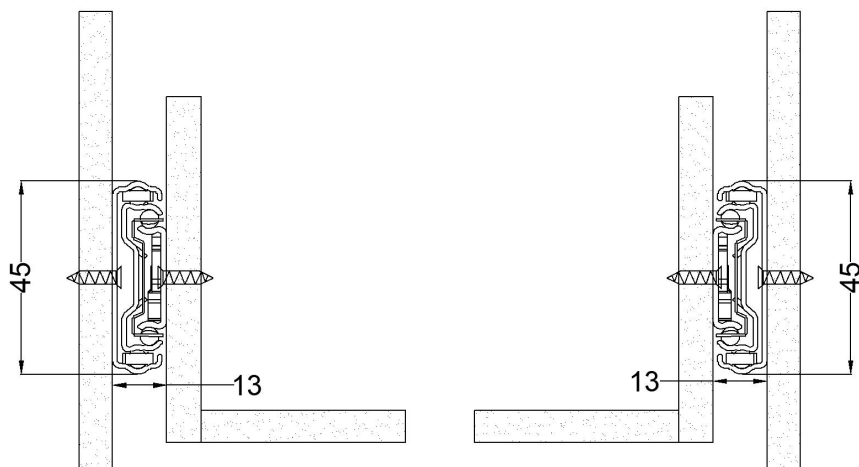

2,2 mm verwijderd van de voorkant van de kast. (Eenheden: mm)

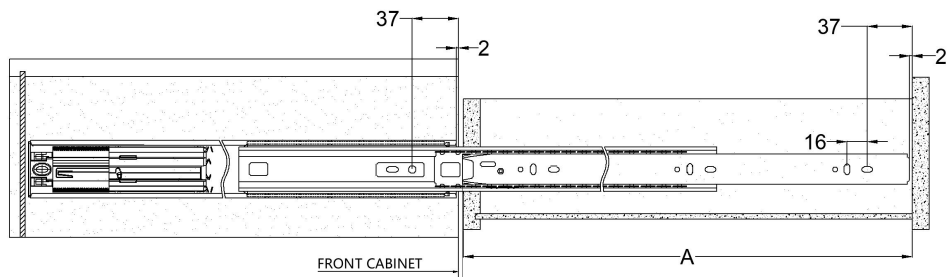

STAP1 : Installatie van de kast met volledige lagere _

13. Installeer de stalen kogelrail aan de binnenkant van de kast volgens de grote tekening van de schroef .

14. Het kralenframe moet plat worden gedrukt met de vijllijm om de installatie van de lade te vergemakkelijken.

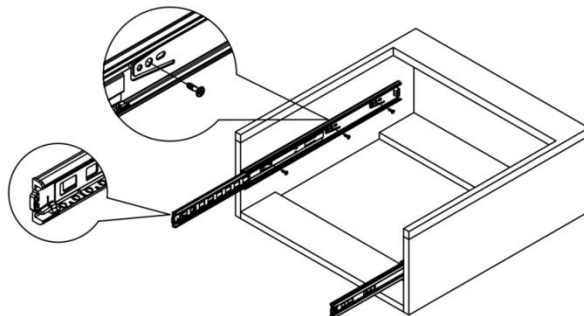

STAP2: Installatie van ladegeleiders

Schroef de kogelrail aan de buitenkant van de lade, zoals weergegeven in het lay-outschema.

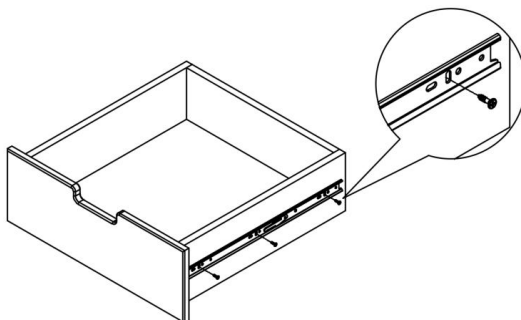

STAP3: Ladeinstallatie

Lijm aan beide zijden van de binnenrail tot aan de bovenste middenrail door de gleuf om de lade op te installeren.

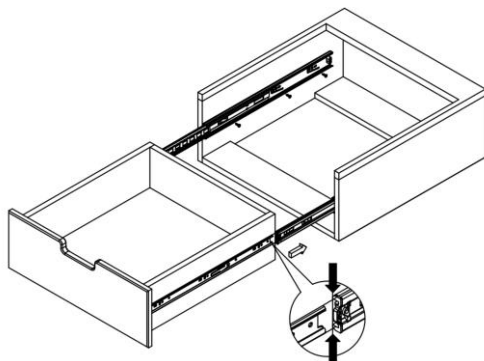

STAP4:Demonteer de lade

Wanneer u de lade verwijdert, trekt u de lade naar buiten door de vork in de vergrote afbeelding volledig naar buiten te trekken.

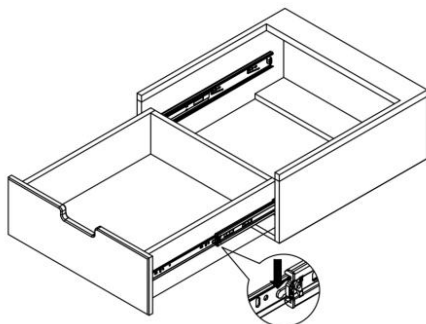

Adres: Baoshanqu Shuangchenglu 803long 11hao 1602A-1609shi
Shanghai

Geïmporteerd naar AUS: SIHAO PTY LTD . 1 ROKEVA
STREETEASTWOOD NSW 2122 Australië

Geïmporteerd naar de VS: Sanven Technology Ltd. Suite 250, 9166
Anaheim Place, Rancho Cucamonga, CA 91730

UK	REP
-----------	------------

Pooledas Group Ltd
Unit 5 Albert Edward House, The Pavilions
Preston, United Kingdom

EC	REP
-----------	------------

SHUNSHUN GmbH
Römeräcker 9 Z2021, 76351
Linkenheim-Hochstetten, Germany

Gemaakt in China

UTDRAGSLÅDOR

MODELL: 4605S2

DRAWER SLIDES

MODELL: 4605S2







Varning - För att minska risken för skada måste användaren läsa instruktionerna noggrant.

VARNING:

1. Vänligen montera produkten i strikt enlighet med instruktionerna. Felaktig montering kan vara farligt.
2. Använd skyddsglasögon och arbetshandskar ordentligt under monteringen.
3. Försök inte att sätta ihop produkten när du känner dig trött eller är påverkad av alkohol, droger eller medicin.
4. Bärförmåga och andra produktparametrar tillämpas endast på den korrekt och färdigmonterade produkten.
5. Separera och räkna alla delar och hårdvara.
6. Förbered följande verktyg: Philips huvudskruvmejsel.
7. Om du använder elverktyg, var noga med att sakta ner och stanna vid behov.
8. Två personer krävs för montering.
9. Följ endast avsedd användning.
Spara instruktionerna.

produkt introduktion

Dellista (st)		
Artikel		
Modell	Glida	Skruvar
4605S2.350-10	10	120
4605S2.350-6	6	72
4605S2.400-10	10	120
4605S2.400-6	6	72
4605S2.450-10	10	120

4605S2.450-6	6	72
4605S2.500-10	10	120
4605S2.500-6	6	72
4605S2.550-10	10	120
4605S2.550-6	6	72
4605S2.600-10	10	120
4605S2.600-6	6	72

Modell	Tillämplig lådlängd (tum)	Glidlängd (mm)	Max. Ladda (kg / lbs)
4605S2.350-10	14	325	100/45,4
4605S2.350-6	14	325	
4605S2.400-10	16	400	
4605S2.400-6	16	400	
4605S2.450-10	18	450	
4605S2.450-6	18	450	
4605S2.500-10	20	500	
4605S2.500-6	20	500	
4605S2.550-10	22	550	
4605S2.550-6	22	550	
4605S2.600-10	24	600	
4605S2.600-6	24	600	

Installationsmått (mm)

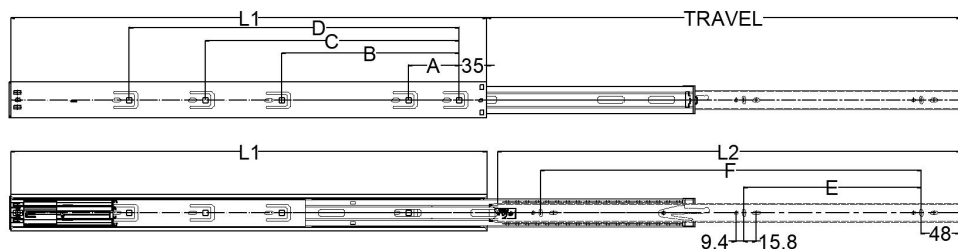

Modell	Storlek (mm)		Resa (mm)	Hålmönster (mm)					
	L1	L2		A	B	C	D	E	F
4605S2.350	350	332	325	64	192	/	/	128	241
4605S2.400	400	382	400	64	224	/	/	160	288
4605S2.450	450	432	450	64	224	288	/	160	320
4605S2.500	500	482	500	64	224	320	/	192	384
4605S2.550	550	532	550	64	224	384	/	192	416
4605S2.600	600	582	600	64	224	352	416	224	480

Installationsprocedur _ _

◆ Observera följande två punkter under installationen :

1. Var uppmärksam på installationsutrymmet på båda sidor. (Enheter: mm)

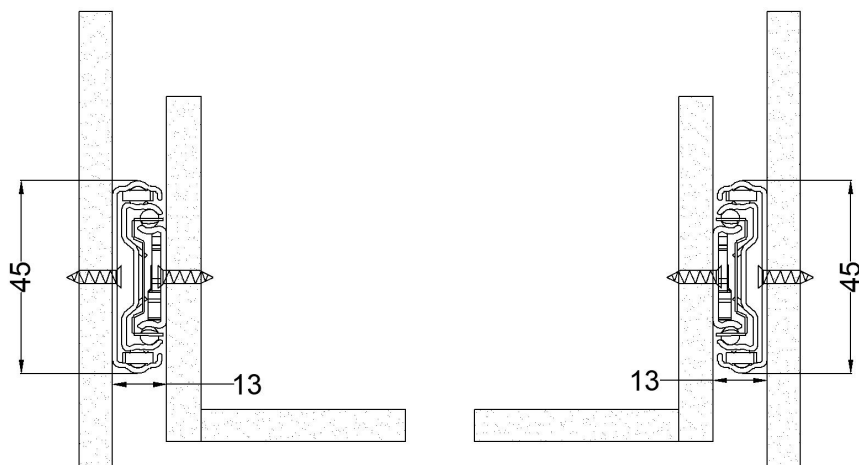

2,2 mm från den främre änden av skåpet. (Enheter: mm)

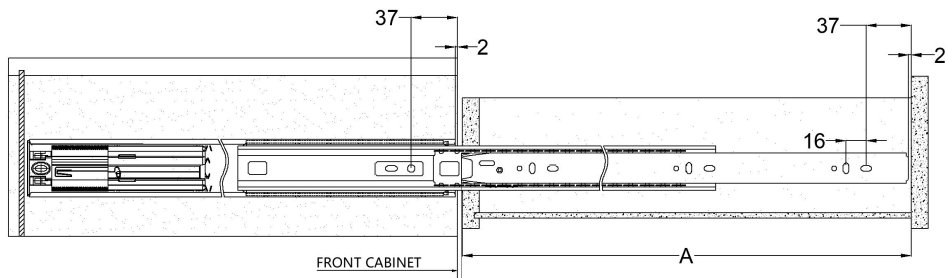

STEG 1: Skåp Installation F eller B eller B öring

15. Montera stålculskenan på insidan av skåpet enligt skruvens stora ritning .

16. Pärlramen ska skjutas platt med fillimmet för att underlätta monteringen av lådan.

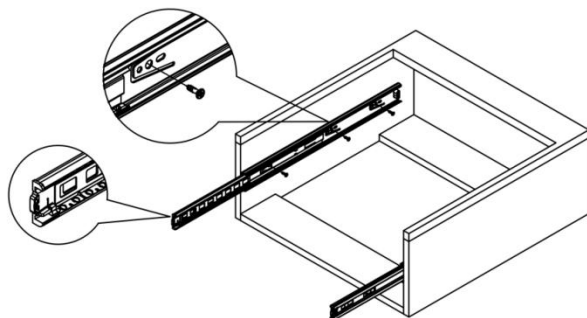

STEG 2: Installation av utdragslådor

Skruva fast kulskenan på utsidan av lådan som visas i layoutdiagrammet.

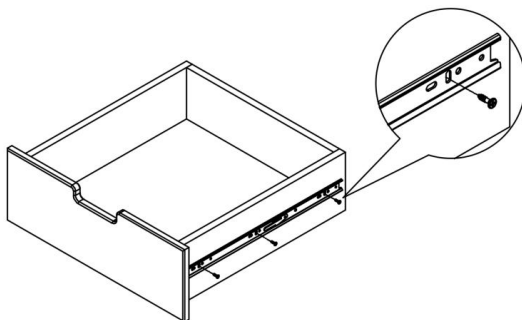

STEG 3: Installation av lådor

På båda sidor av den inre skenan till den övre mittskenan limma genom skåran för att installera lådan på.

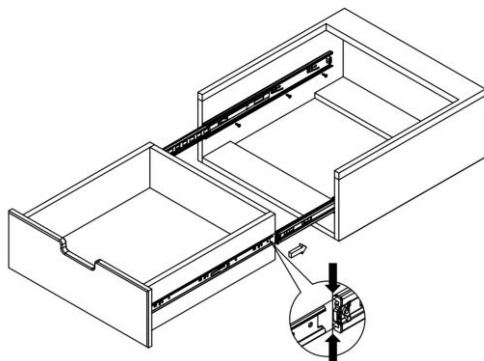

STEG 4: Demontera lådan

När du tar bort lådan, dra ut lådan genom att använda gaffeln i den förstörade bilden för att dra ut den helt.

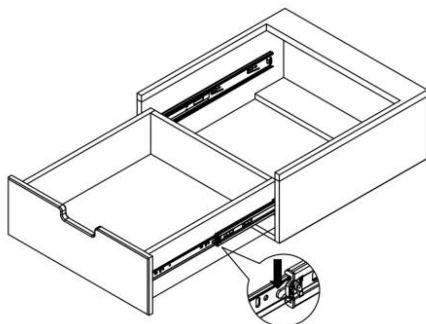

Adress: Baoshanqu Shuangchenglu 803long 11hao 1602A-1609shi
Shanghai

Importerad till AUS: SIHAO PTY LTD . 1 ROKEVA STREETEASTWOOD
NSW 2122 Australien

till **USA:** Sanven Technology Ltd. Suite 250, 9166 Anaheim Place, Rancho
Cucamonga, CA 91730

UK	REP
-----------	------------

Pooledas Group Ltd
Unit 5 Albert Edward House, The Pavilions
Preston, United Kingdom

EC	REP
-----------	------------

SHUNSHUN GmbH
Römeräcker 9 Z2021, 76351
Linkenheim-Hochstetten, Germany

Tillverkad i Kina

