

woltu®

woltu®

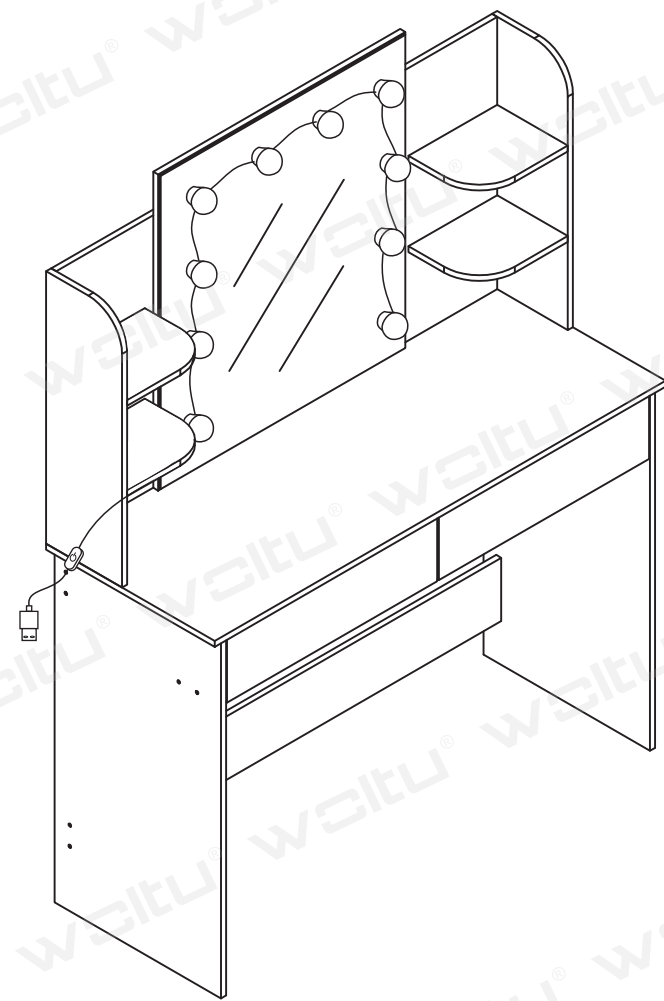

FR
Cet appareil
et ses ampoules
se recyclent

À DÉPOSER
EN MAGASIN

OU

À DÉPOSER
EN DÉCHÈTERIE

Points de collecte sur www.quefairedemesdechets.fr
Privilégiez la réparation ou le don de votre appareil !

Installation Manual

Aufbauanleitung / Manuel
d'installation / Manuale di istruzioni /
Instrucciones de instalación

Einleitung

- Bitte lesen Sie die folgenden Anweisungen sorgfältig durch und verwenden Sie das Produkt wie beschrieben.
- Wenn das Produkt an Dritte weitergegeben wird, geben Sie alle notwendigen Anleitungen mit.
- Um Ihnen eine klare und allgemeine Zusammenfassung zu zeigen, haben wir nicht alle potenziellen Szenarien und Details beschrieben, die beim Verwenden und Aufbauen erscheinen. Wenn Sie weitere Informationen und Unterstützung bei der Anwendung benötigen, wenden Sie sich gerne an uns.

Montagehinweise

- Vergewissern Sie sich vor dem Aufbau des Produkts anhand der Angaben, dass alle Zubehörteile vorhanden und unbeschädigt sind. Falls nicht, setzen Sie sich rechtzeitig mit uns in Verbindung.
- Das Produkt ist mit einer Vielzahl von Kleinteilen geliefert. Um ein Verschlucken der Kleinteile zu vermeiden, halten Sie Ihre Kinder bei der Montage fern.
- Verwenden Sie das Produkt erst, wenn es ordnungsgemäß und vollständig zusammengebaut ist.
- Um die durch herumfliegende Späne verursachte Gefahr möglichst zu minimieren, empfehlen wir manuelle Montage. Beim Einsatz von Akkuschauber stellen Sie bitte das richtige Drehmoment ein.
- Achten Sie darauf, dass die Schrauben beim Festziehen nicht überdreht werden. Sonst werden die entsprechenden Zubehörteile beschädigt und nicht richtig befestigt.
- Die mitgelieferten LED-Lampen werden mit doppelseitigen Klebebändern befestigt. Es fordert eine saubere, trockene, glatte Wand ohne Rost und Ölschmutz. Halten Sie beim Aufkleben die Glühbirne gegen die Stelle etwa 30 Sekunden lang fest. In 24 Stunden kann das Klebeband erst seine optimale Klebekraft erreichen.

Sicherheitshinweise

- Um ein Umkippen zu verhindern, empfehlen wir, das Produkt auf einer harten, flachen und ebenen Fläche gegen eine Wand zu stellen und mit der mitgelieferten Kippsicherung an der Wand zur Stabilisierung zu befestigen.

- Überprüfen Sie das Produkt vor jedem Gebrauch, um lockere Verbindungen zu vermeiden.
- Wenn sich etwas im Laufe der Nutzung gelockert haben sollte, ziehen Sie die Schrauben bitte erneut nach.

Pflegehinweise

- Tauchen Sie das Produkt niemals in Wasser und sprühen Sie niemals die Flüssigkeit direkt auf das Produkt.
- Verwenden Sie neutrales Reinigungsmittel und das Abwischen soll sofort nach dem Sprühen des Reinigungsmittels durchgeführt werden.
- Reinigen Sie das Produkt mit milden Reinigungsmitteln und wischen Sie es mit einem weichen feuchten Tuch ab. Verwenden Sie keine scharfen oder scheuernden Reinigungsmittel.

Warnung

- Dieses Gerät ist so ausgelegt, dass es den gezeigten maximalen Belastungen standhält. Das Überschreiten dieser Belastungsgrenze kann zu Durchbiegen, Instabilität, Zusammenbruch des Produkts und / oder schweren Verletzungen führen.
- Lassen Sie Kinder nicht unbeaufsichtigt an dem Produkt rumklettern oder baumeln.
- Legen Sie alle schweren Gegenstände auf die untere Ablage.
- Halten Sie Ihre Kinder und Babys vom Verpackungsmaterial unzugänglich fern. Die Tüten und Folien könnten Erstickungsgefahr und andere unvorhergesehene Gefahren verursachen.

Kundendienst

- Bitte wenden Sie sich bei Problemen an unser Kundenservice-Team. Sie können uns über das Verkaufsportal, bei dem Sie bestellt haben, kontaktieren.

General Guidelines

- Please read the following tips carefully and use the product correctly.
- If you buy the product for others, please keep these tips and send them to the receiver.
- In order for you to have a clear and summary preview, we have not described all possible scenarios and installation details that may be involved. If you need more information and help, please contact us.

Assembly Notes

- Please check all the parts according to the instructions before installation and contact us if any parts are missing or damaged.
- Please keep children away during installation to avoid accidental swallowing of tiny accessories.
- Please do not use the product before finishing the installation.
- To reduce the risk of hurting from wood shavings, please install by hand tools. If use electric tool, please choose the correct torque force.
- Please do not fix the screws extra tight, or the parts might be damaged.
- The attached LED bulbs are fixed with double-sided adhesive tapes. The adhesive surface for installation must be clean, dry, smooth and free from rust and grease. When sticking the bulbs, they must be pressed for about 30 seconds and it will take 24 hours to achieve the best bonding strength.

Safety Warnings

- To avoid the risk of overturning, it is recommended to place the product on a flat and solid ground and fix the safety device to the wall.
- Please check if any joints are loosing before each use.
- The screws may be loose after using the product for a while, just tighten them again.

Product Care Tips

- Do not immerse the product in water and spray water on the product.
- Use a mild solution for cleaning and dry the liquid cleaner immediately after spraying.
- Wipe with a damp cloth. Do not use harsh or abrasive cleaners.

Warnings

- The product is designed to withstand the maximum load shown. Overload may result in sag, instability, collapse and/or serious injury.
- Do not allow children to climb on this product.
- Please put the heavier items on the lower shelves.
- After installation, please keep the packaging materials out of reach of children, especially babies to prevent unforeseen hazards such as suffocation caused by the non-woven fabrics, plastic bags, bubble bags, etc. contained in the packaging.

Customer Service

- If any questions, please contact our customer service team through the corresponding purchase platform.

FR

Introduction

- Veuillez lire attentivement les manuels suivants et utiliser correctement le produit, s'il vous plaît!
- Si vous livrez le produit à un tiers, veuillez conserver ces manuels et transmettez-les-leur, s'il vous plaît!
- Afin que vous ayez un aperçu clair et général, nous n'avons pas décrit tous les scénarios possibles et les détails d'installation qui peuvent être impliqués. Si vous avez besoin de plus d'informations et d'aide, n'hésitez pas à nous contacter, s'il vous plaît!

Notes d'assemblage

- Il est nécessaire de vérifier la quantité de toutes les pièces installées avant l'installation, s'il en manque, veuillez nous contacter.
- Ne laissez pas les enfants participer au processus d'installation pour éviter que les enfants avalent de petits accessoires par accident.
- Veuillez ne pas utiliser ce produit avant de réussir l'installation.
- Afin de minimiser le risque de copeaux, veuillez essayer de l'installer à la main. Lorsque vous utilisez des outils électriques, veuillez sélectionner la bonne force de torsion.
- Veuillez ne pas serrer trop les vis, sinon les pièces pourraient être endommagées.
- Les ampoules LED doivent être fixées avec du ruban adhésif double face. La surface où vous allez installer les ampoules doit être propre, sèche, lisse et sans tache de rouille et d'huile. Vous devez appuyer les doigts sur les ampoules pour environ 30 secondes et il faut attendre 24 heures pour obtenir la meilleure adhésivité.

Avertissements de sécurité

- Mettez ce produit sur une surface solide et plate. S'il est déposé près d'un mur, nous vous recommandons de l'attacher sur le mur avec des sangles anti-basculantes.
- Avant l'utilisation, veuillez vérifier l'état des jonctions de ce produit pour

assurer sa stabilité.

- Si les vis se desserrent après un certain temps d'utilisation, veuillez les resserrer.

Entretien du produit

- N'immergez pas le produit dans l'eau ou n'y vaporisez pas de liquide directement.
- Pour le nettoyage, veuillez utiliser une solution douce et l'essuyez immédiatement après la pulvérisation.
- Veuillez essuyer le produit avec un chiffon humide. N'utilisez pas de nettoyeurs agressifs ou abrasifs.

Avvertissements

- Ne mettez pas des objets de surpoids sur ce produit. La surcharge peut conduire à l'affaissement, l'instabilité, l'effondrement du produit et / ou des blessures graves.
- Ne laissez pas les enfants grimper sur ce produit.
- Veuillez ranger les articles lourds sur les étagères inférieures.
- Une fois le montage terminé, mettez l'emballage du produit dans un endroit hors de portée des enfants, en particulier des nourrissons. L'emballage contient des pièces telles que des non-tissés, des sacs en plastique, du papier bulle qui peuvent entraîner des dangers inattendus tels que la suffocation.

Service après-vente

- Si vous avez des questions, veuillez contacter notre équipe du service de client sur la plateforme d'achat correspondant à votre commande, s'il vous plaît.

IT

Linee guida generali

- Si prega di leggere attentamente le istruzioni riportate di seguito e di utilizzare correttamente il prodotto.
- Se il prodotto deve essere consegnato a terzi, si prega di conservare e includere queste istruzioni.
- Al fine di fornire un'anteprima di riepilogo chiara e generale, non abbiamo descritto tutti i possibili scenari e dettagli di montaggio che possono essere coinvolti. Se hai bisogno di aiuto e maggiori informazioni, non esitare a

contattarci.

Avvertenze per il montaggio

- Prima del montaggio, controllare che tutte le componenti elencate nelle istruzioni siano presenti e in buone condizioni, in caso di parti mancanti o danneggiate, non procedere al montaggio e contattarci immediatamente.
- Questo prodotto contiene piccoli accessori come viti e chiodi, per evitare il rischio di ingestione accidentale, non lasciare che i bambini partecipino al montaggio. Per evitare i rischi di soffocamento, tenere le parti in plastica fuori dalla portata di bambini e animali.
- Accertarsi che il prodotto sia stato montato correttamente prima di utilizzarlo.
- Per ridurre al minimo i rischi causati dai trucioli, si prega di procedere al montaggio manualmente. In caso di utilizzo di strumenti elettrici, si prega di selezionare la potenza di rotazione adeguata.
- Non stringere eccessivamente le viti, in quanto certe parti potrebbero danneggiarsi e non fissarsi in modo corretto.
- Le lampadine a LED incluse devono essere fissate con i dischetti biadesivi e la superficie sulla quale devono essere installate deve essere pulita, asciutta, liscia e priva di ruggine e olio. Quando si incollano le lampadine, è necessario tenerle premute per circa 30 secondi, inoltre, servono 24 ore per raggiungere la massima adesione.

Avvertenze di sicurezza

- Per evitare i rischi di ribaltamento, si consiglia di posizionare il prodotto su una superficie piana e compatta. Se si posiziona il prodotto accanto le pareti, fissarlo con l'accessorio antiribaltamento in dotazione.
- Prima di ogni utilizzo, controllare che non ci siano parti del prodotto allentate.
- Se dopo un periodo di utilizzo certe componenti iniziano ad allentarsi, stringere le viti a dovere.

Consigli per la cura del prodotto

- Non immergere in acqua e non spruzzare direttamente liquidi sul prodotto.
- Utilizzare una soluzione detergente neutra e ripulirla immediatamente dopo l'uso.
- Pulire il prodotto con un panno morbido umido. Non utilizzare detergenti aggressivi o abrasivi.

Attenzione

- Questo prodotto è progettato per reggere il carico massimo mostrato. Il superamento del carico massimo può causare cedimenti, instabilità, collasso del prodotto e/o gravi lesioni.
- Non consentire ai bambini di arrampicarsi sul prodotto.
- Posizionare gli oggetti pesanti sui ripiani inferiori.
- Una volta terminato il montaggio posizionare l'imballaggio in un luogo fuori dalla portata dei bambini, in particolar modo dei neonati. L'imballaggio contiene parti come TNT, sacchetti di plastica, pluriball che possono causare pericoli imprevisti come il soffocamento.

Assistenza post-vendita

- Se avete qualsiasi problema, si prega di contattare il nostro servizio clienti attraverso il canale d'acquisto in cui è stato effettuato l'ordine.

ES

Acerca del manual

- Lea las siguientes instrucciones detenidamente y utilice el producto correctamente.
- Si entrega el producto a un tercero, conserve estas instrucciones y entrégueselas.
- Para que tenga una vista previa clara y resumida, no hemos descrito todos los escenarios posibles y los detalles de instalación relativos. Si necesita más información y ayuda, comuníquese con nosotros.

Instrucciones de montaje

- Antes del montaje, asegure que todos los componentes estén presentes; si falta alguna pieza, póngase en contacto con nosotros.
- Por favor no deje al niño participar en el proceso de montaje porque hay pequeños accesorios como tornillos y clavos que podrían ser tragados accidentalmente por los niños. Mantenga las piezas plásticas fuera del alcance de los niños y las mascotas para evitar el riesgo de asfixia.
- No usa este producto hasta que se termine la instalación correcta y entera.
- Para minimizar el daño por el serrín, realice el montaje manualmente. En caso de utilizar herramientas eléctricas, seleccione una con la potencia de rotación adecuada.
- No apriete demasiado los tornillos. De lo contrario, algunos componentes se dañarán y no se ajustarán correctamente.

- Las bombillas de LED deben fijarse con cinta adhesiva de doble cara. La superficie donde va a pegarlas debe estar limpia, seca, lisa sin óxido ni la suciedad de aceite. Al pegar las bombillas, debería mantenerlas durante unos 30 segundos. Se necesitan 24 horas para lograr la máxima adherencia.

Advertencias de seguridad

- Para evitar peligros de vuelco, coloque este producto sobre una superficie sólida y plana contra la pared. Le recomendamos que la asegure con el accesorio antivuelco.
- Cada vez antes de usarlo, por favor verifique si todas las partes estén bien sujetadas y no haya partes sueltas.
- Si algunos componentes están flojos después de usar un tiempo, se puede apretar los tornillos para fijar.

Consejos para el cuidado del producto

- No lo deja a remojo, ni pulverizar líquidos directamente sobre el producto.
- Para limpiarlo, use el detergente neutro y límpielo inmediatamente después de su uso.
- Limpiar el producto con un paño mojado. No use detergentes químicos o corrosivos.









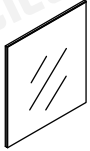

Atenciones

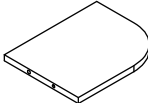
- Este producto está diseñado para soportar las cargas máximas que se muestran. Exceder la carga máxima puede provocar la inestabilidad y causará lesiones graves.
- No deja a los niños subir al producto.
- Los objetos pesados deben ponerse en la balda inferior.
- Por favor deja los embalajes fuera del alcance de los niños, sobre todo, a los bebés. El textil no tejido, bolso plástico incluidos en el embalaje podrán causar peligros imprevistos, por ejemplo: asfixia.

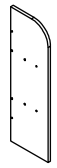

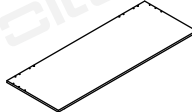
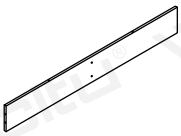
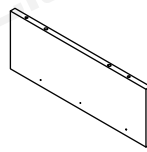

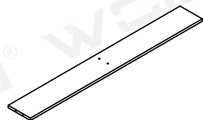

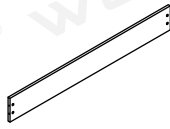
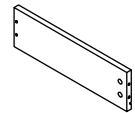
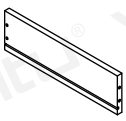
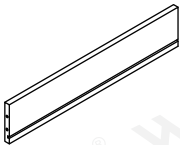
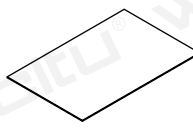
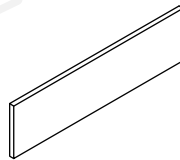
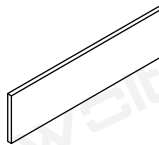









Servicio postventa

- Si tiene alguna pregunta, por favor comuníquese con nuestro equipo de servicio al cliente a través de la plataforma de compra de pedidos correspondientes.

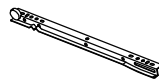
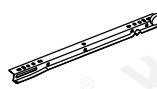
UNIT:MM

1 ×1pc 	2 ×1pc 	3 ×1pc 	4 ×2pcs 
5 ×1pc 	6 ×1pc 	7 ×2pcs 	8 ×1pc 
9 ×1pc 	10 ×1pc 	11 ×1pc 	12 ×1pc 
13 ×1pc 	14 ×1pc 	15 ×2pcs 	16 ×2pcs 
17 ×2pcs 	18 ×2pcs 	19 ×1pc 	20 ×1pc 

UNIT:MM

A ×24pcs 	B ×24pcs 	C ×30pcs 	D ×24pcs 	E ×28pcs 
F ×12pcs 	G ×1pc 	H ×4pcs 	I ×12pcs 	J ×2pcs 
K ×2pcs 	L ×2pcs 	M ×2pcs 	N ×1pc 	O ×4pcs 
P ×1pc 	Q ×2pcs 	R ×12pcs 	S ×1pc 	

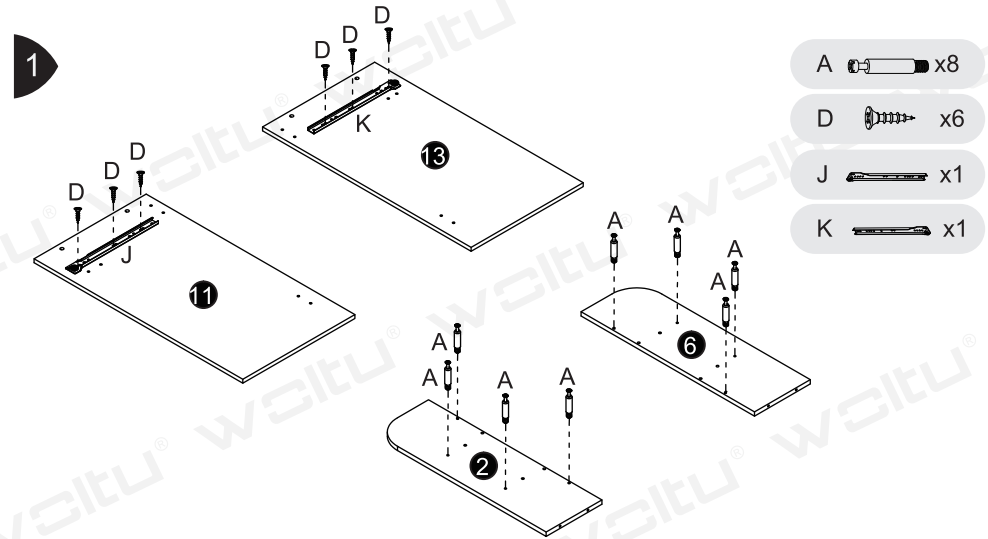
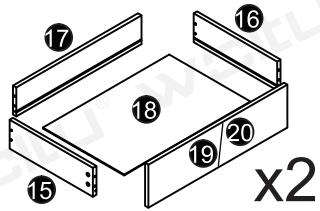
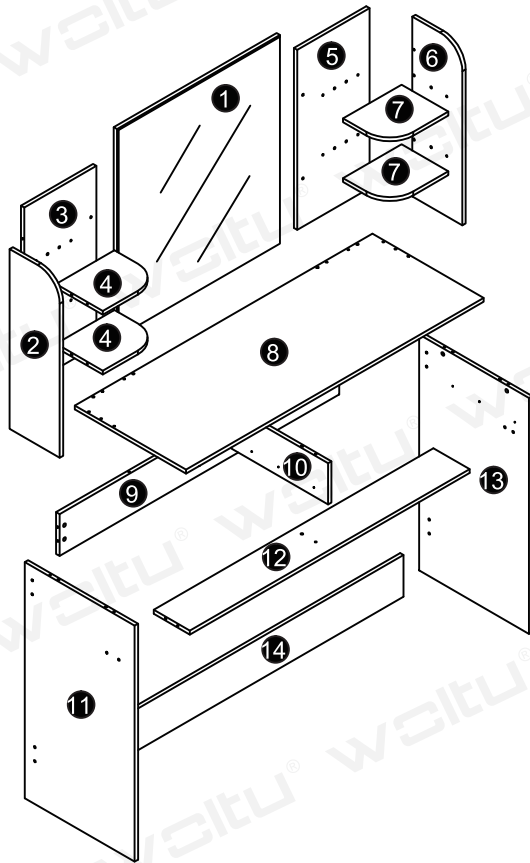

A  x8

D  x6

J  x1

K  x1

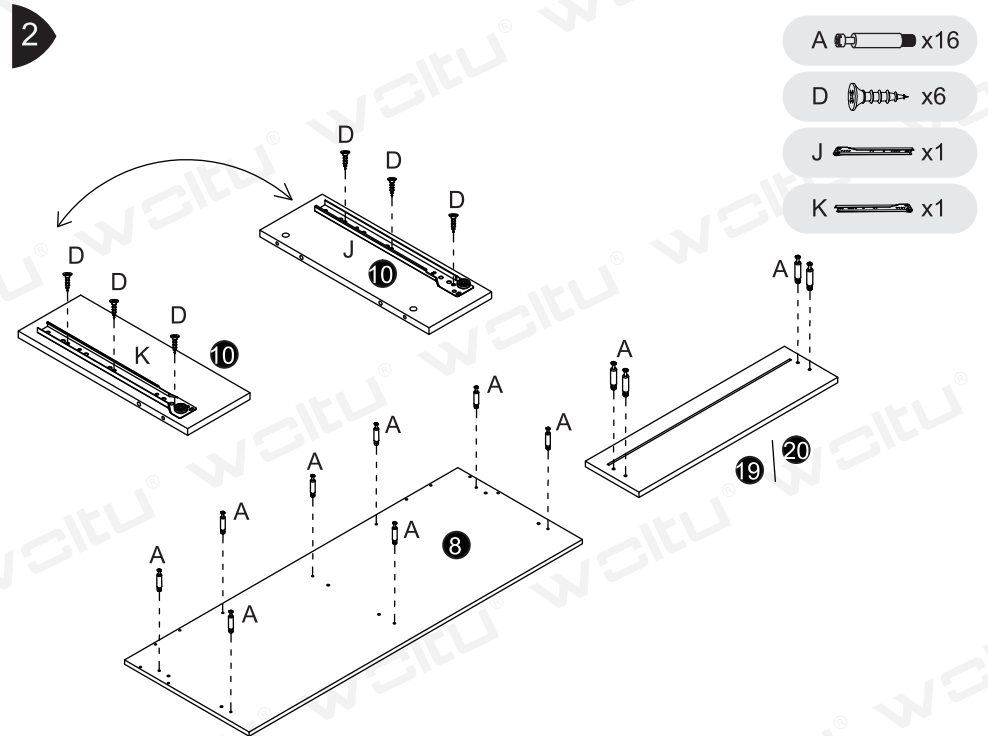

A  x16





D  x6

J  x1

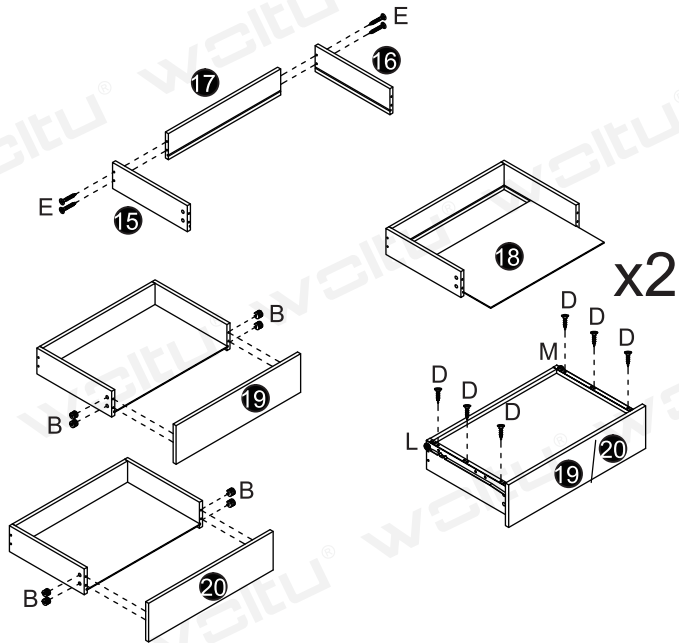
K  x1



3



- B  x8
- D  x12
- E  x8
- L  x2
- M  x2

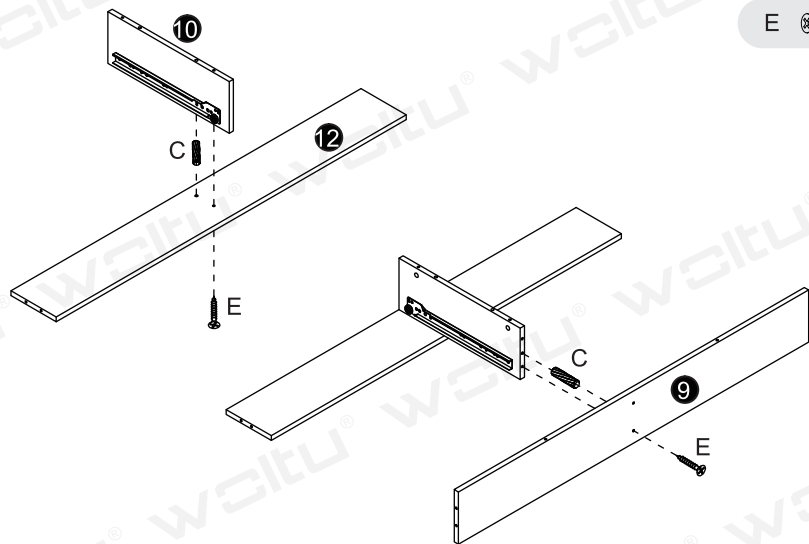

4



- C  x2
- E  x2

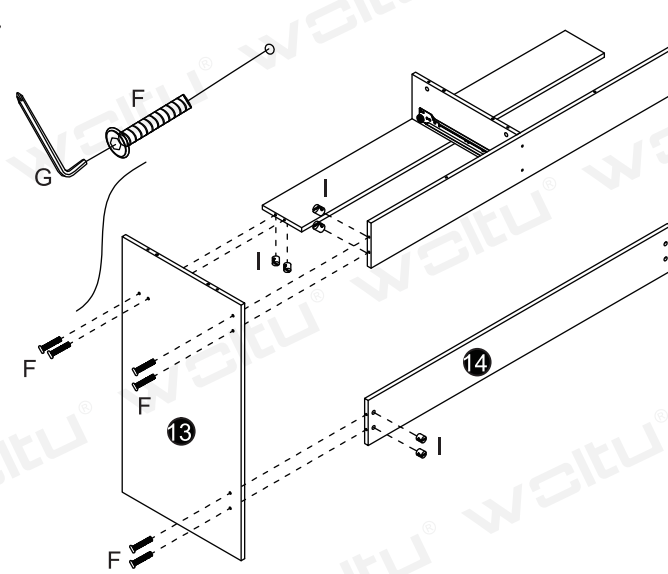

5

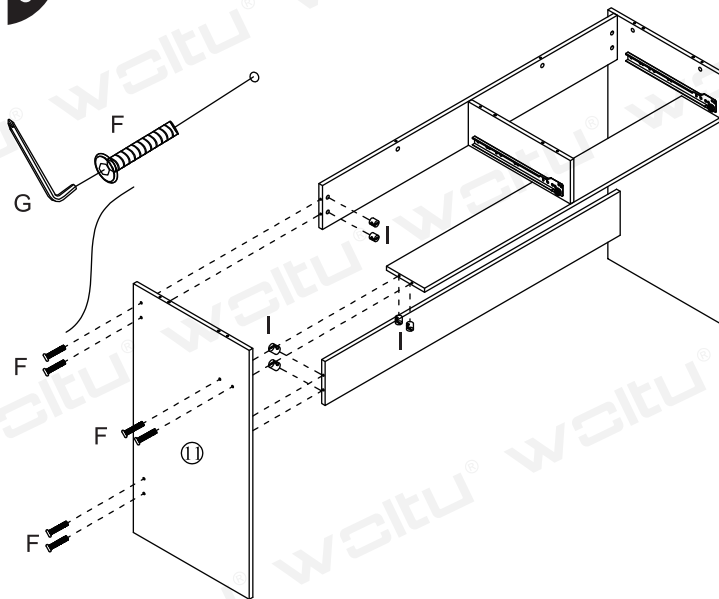

- F  x6
- I  x6
- G  x1

6



- F  x6
- I  x6
- G  x1

7

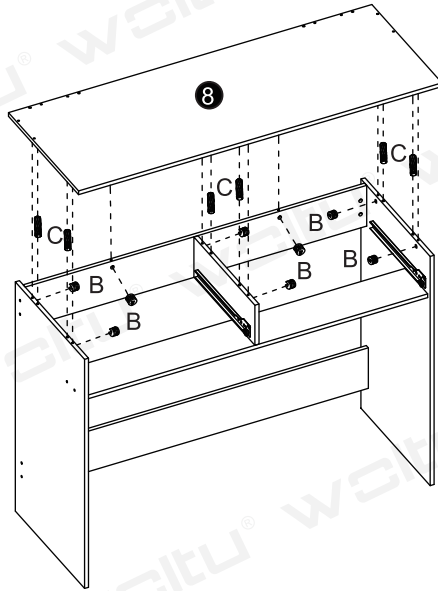

B  x8

C  x6

9

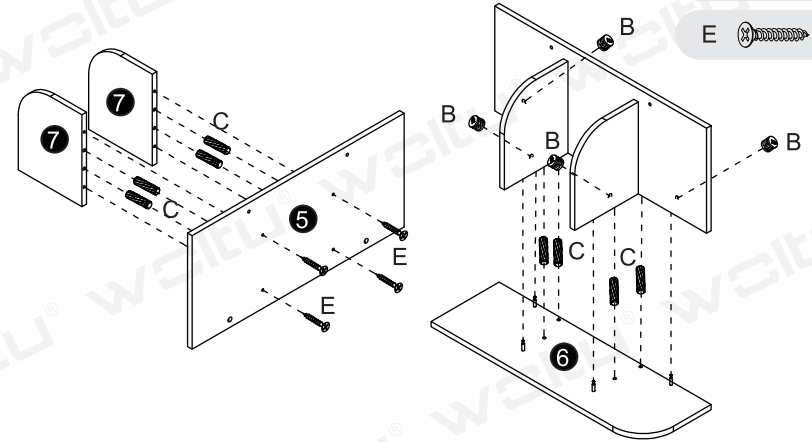

B  x4

C  x8

E  x4

8

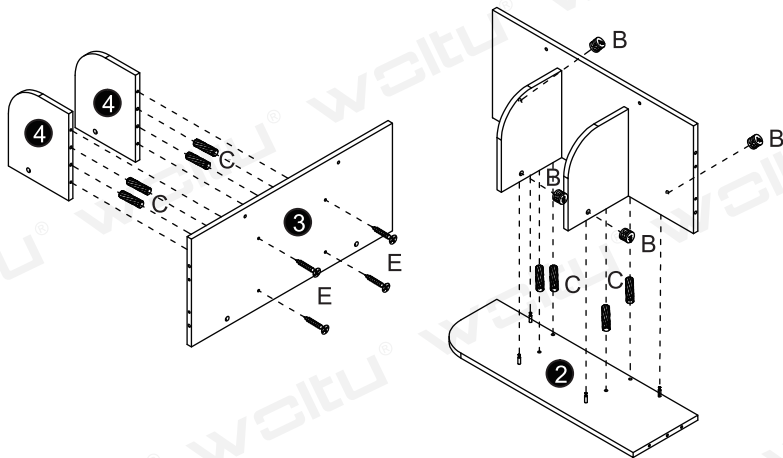

B  x4

C  x8

E  x4

10

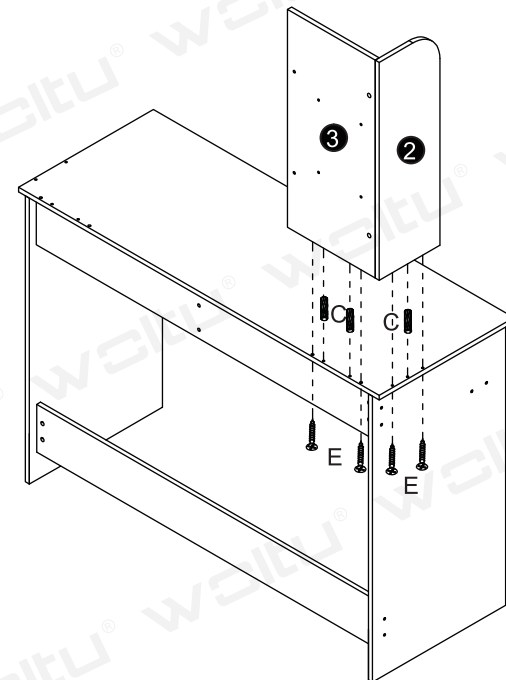

C  x3

E  x4

11

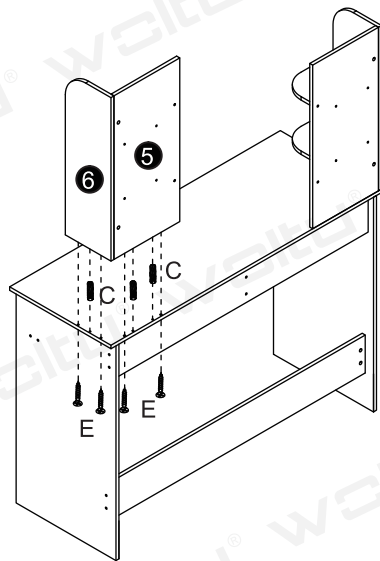

C  x3

E  x4

13

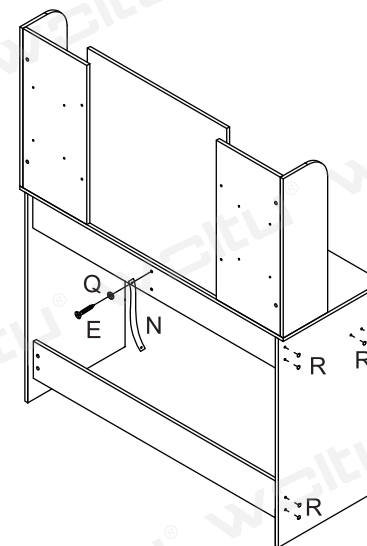

E  x1

N  x1

Q  x1

R  x6

12

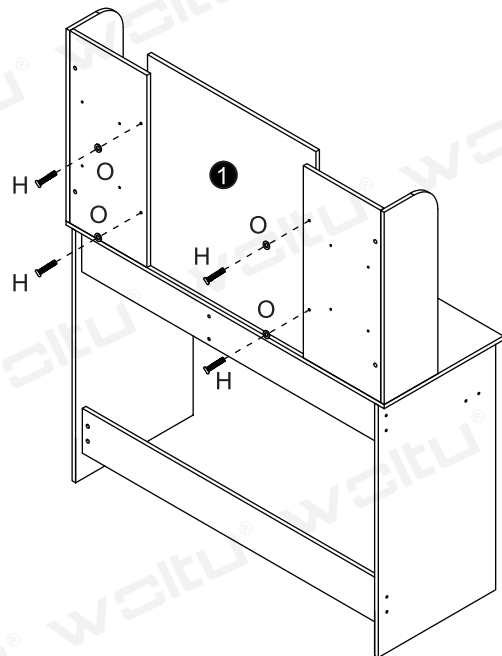

H  x4

O  x4

14

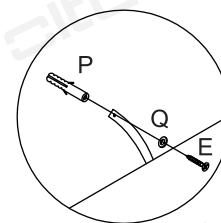

E  x1

P  x1

Q  x1

R  x6

S  x1

