



EnergyBrush-1500



PEUGEOT OUTILLAGE

150610-3-E-20230802



- FR - Manuel d'utilisation (Notice originale) :
- EN - Handboek (Vertaling van het oorspronkelijke):
- ES - Manual (Traducción del original):
- IT - Manual (tradução do manual original) :
- PT - Manual (Traduzione dell'avvertenza originale):
- NL - Using Manual (Original manual translation):

Rénovateur filaire
Corded renovator
Renovador con cable
Ristrutturatore cablato
Renovador com fio
Vernieuwende draad

peugeot-outillage.com



MERCI !



En choisissant ce produit **PEUGEOT**, vous permettez d'en diminuer l'impact environnemental !

En retravaillant l'emballage, nous avons supprimé **60 %** des produits dérivés des hydrocarbures et réduit son volume de **33 %**.

Ces opérations ont ainsi permis **d'abaisser ses émissions de gaz à effet de serre :**

- **il utilise moins de ressources naturelles,**
- **son volume transporté est nettement plus faible.**

>>> **Pour en savoir plus, flashez ce code et retrouvez toutes les informations sur notre site**



A

Description et repérage des organes de la machine

Description and location of machine parts

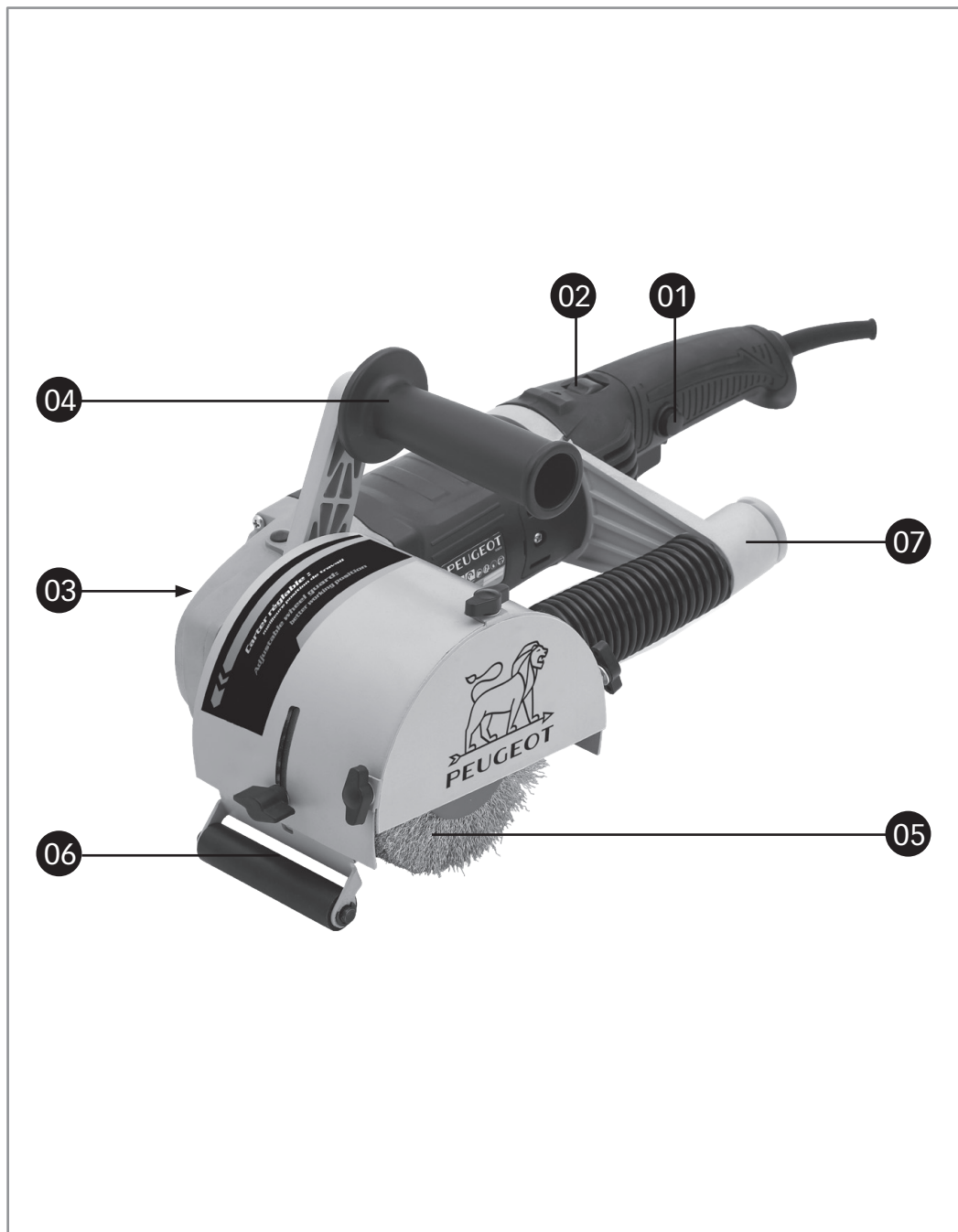

C**Contenu du carton**
Contents of box

10

11

12

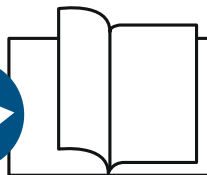

03

**FR**
Cet appareil
et ses accessoires
se recyclentA DÉPOSER
EN MAGASIN
ou
A DÉPOSER
EN DÉCHÈTERIEPoints de collecte sur www.quairendunorddechets.fr
Privilégiez la réparation ou le don de votre appareil !**FR**



03

01

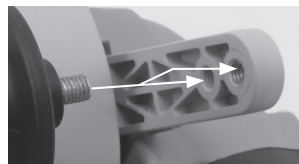
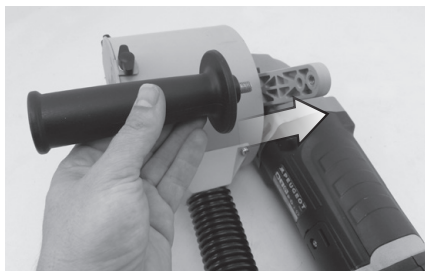

Poignée ajustable sur deux positions
 Verstelbare handgreep in twee posities
 Mango ajustable de dos posiciones
 Puxador ajustável de duas posições
 Maniglia regolabile a due posizioni
 Two-position adjustable handle

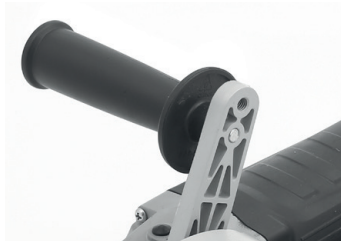

Montage de la poignée pour droitier / gaucher
 Rechts / linkshandige handgreepmontage
 Montaje de manija derecha / izquierda
 Conjunto de pega direita / esquerda
 Assemblaggio maniglia destra / sinistra
 Right / left handed handle assembly

D

Assemblage de la machine Machine assembly



05

02

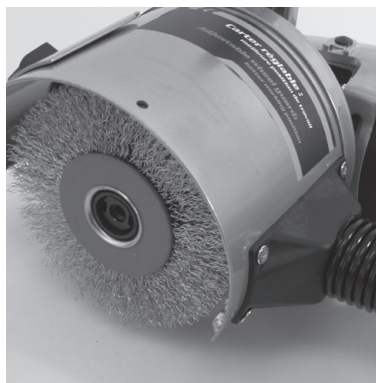
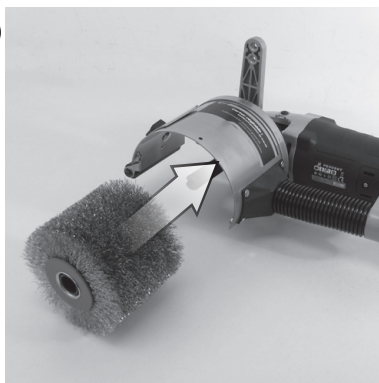

10



11



12

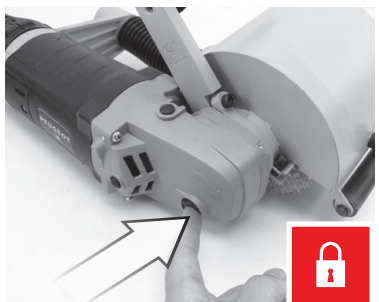
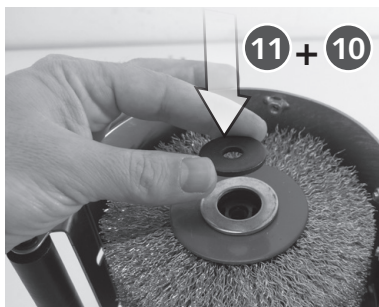

D

Assemblage de la machine Machine assembly



03

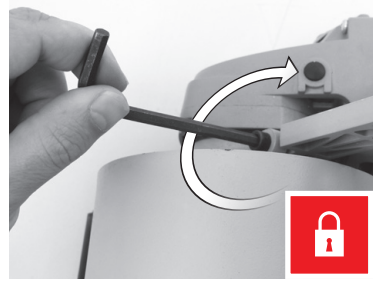
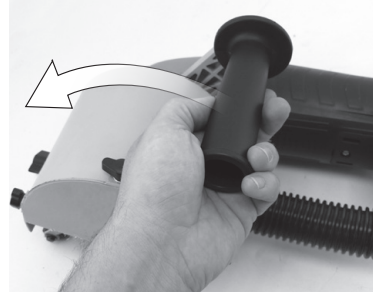
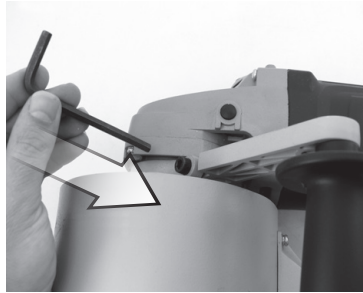

E

Utilisation de la machine Machine use

01



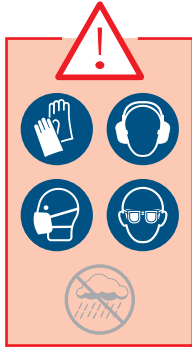
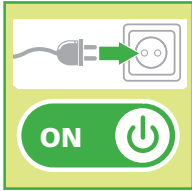

03

OPTION

100901 *EnergyClean-20L*

Aspirateur à décolmatage pour salissures sèches
Unclogging vacuum cleaner for drywalls
Ontstoppen stofzuiger voor droge muren
aspiradora desobstrucción de las paredes secas
aspirador desobstrução de paredes secas
aspirapolvere unclogging per muri a secco

01

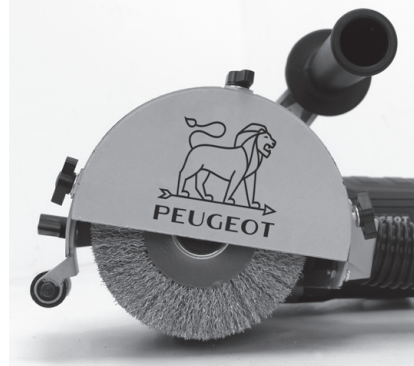
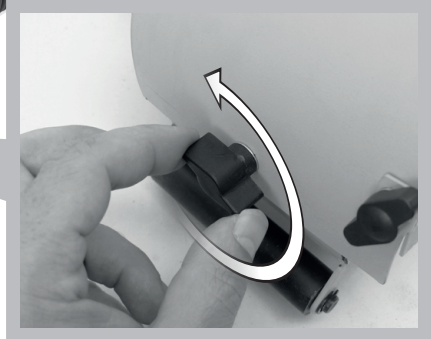

En position marche, le voyant blanc s'allume ;
il se met à clignoter quand il détecte une surintensité.

In de op positie, zal het witte licht verlichten;
Hij krijgt Knippert wanneer het detecteert een overstroom.
En la posición ON, la luz blanca se encenderá;
La luz se Parpadea cuando se detecta una sobrecorriente.
Na posição on, a luz branca iluminar-se-á;
Ele fica Piscando quando detecta uma sobrecorrente.
In posizione on, la luce bianca si illuminerà;
Ottiene Lampeggia quando rileva una sovracorrente.
In the ON position, the white light will switch on;
It gets flashing when it detects an overcurrent.

1800 W MAXI

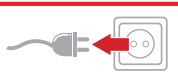

Avant toute opération sur la maintenance de la machine, la débrancher du secteur IMPERATIVEMENT !

Voor elke operatie; op onderhoud van de automaat, haal de stekker uit het stopcontact VERPLICHT!

Antes de cualquier operación en mantenimiento de la máquina, desconectarlo de la red ¡IMPERATIVAMENTE!

Antes de qualquer operação em manutenção da máquina, desligue-o da rede IMPERATIVAMENTE!

Prima di qualsiasi operazione in manutenzione della macchina, scollegarlo dalla rete IMPERATIVAMENTE!

Before any operation on maintenance of the machine, disconnect it from the mains IMPERATIVELY!

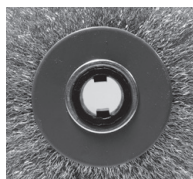

01



X3

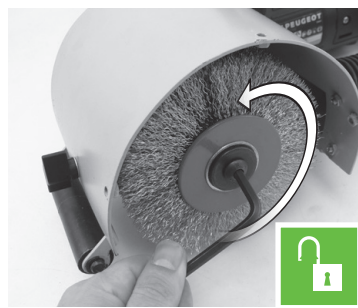
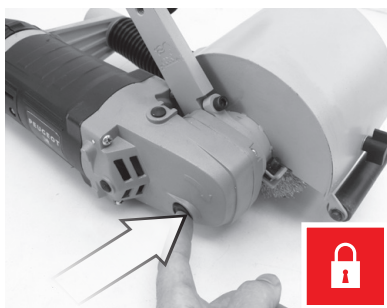
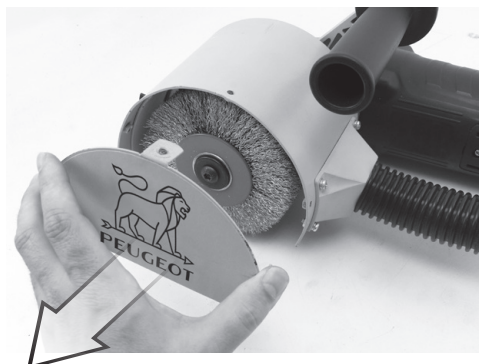
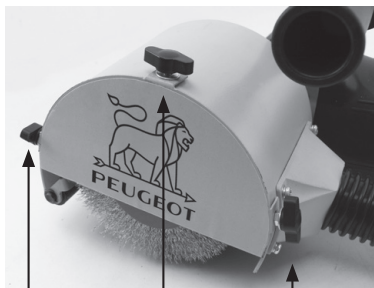



Option - Opcional - Opzione - Opção - Optie - Option

Brosse pour dégriser - décapage léger

Borstel voor ontruuchtering - lichtstrippen
Cepillo para sobriedad - desvanecimiento ligero
Pincel para sobering - descascamento claro
Spazzola per fare sobri - spogliatura leggera
Brush for sobering - light stripping



800301

Brosse pour nettoyer et dégrasser

Penseel om schoon te maken en schoon te maken
Cepillo para limpiar y limpiar
Escova para limpar e limpar
Spazzola per pulire e pulire
Brush to clean and clean



800302

Brosse pour poncer les surfaces planes

Borstel om vlakke oppervlakken te schuren
Cepillar para lijar superficies planas
Escovar para lixar superficies planas
Spazzola per levigare le superfici piate
Brush to sand flat surfaces

40

Grain / Grit

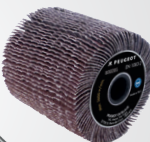

x 2
pcs

800303

Brosse pour poncer les surfaces planes

Borstel om vlakke oppervlakken te schuren
Cepillar para lijar superficies planas
Escovar para lixar superficies planas
Spazzola per levigare le superfici piate
Brush to sand flat surfaces

80

Grain / Grit



x 2
pcs

800304

Brosse à lamelles pour poncer les surfaces incurvées

Lamellenborstel voor het schuren van gebogen oppervlakkenOntstoppen
Cepillo lamella para lijar superficies curvas
Escova Lamella para lixar superficies curvas
Pennello lamellare per levigare superfici curve
Lamella brush for sanding curved surfaces

40

Grain / Grit

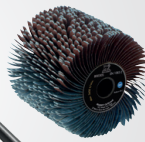

x 2
pcs

800305

Brosse à lamelles pour poncer les surfaces incurvées

Lamellenborstel voor het schuren van gebogen oppervlakkenOntstoppen
Cepillo lamella para lijar superficies curvas
Escova Lamella para lixar superficies curvas
Pennello lamellare per levigare superfici curve
Lamella brush for sanding curved surfaces

80

Grain / Grit

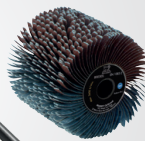

x 2
pcs

800306



02



Avant toute opération sur la maintenance de la machine, la débrancher du secteur **IMPERATIVEMENT !**

Voor elke operatie: op onderhoud van de automaat, haal de stekker uit het stopcontact **VERPLICHT!**

Antes de cualquier operación en mantenimiento de la máquina, desconectarlo de la red **¡IMPERATIVAMENTE!**

Antes de qualquer operação em manutenção da máquina, desligue-o da rede **IMPERATIVAMENTE!**

Prima di qualsiasi operazione in manutenzione della macchina, scollegarlo dalla rete **IMPERATIVAMENTE!**

Before any operation on maintenance of the machine, disconnect it from the mains **IMPERATIVELY!**

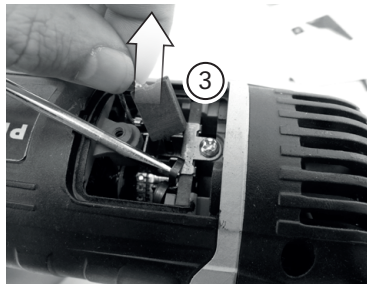
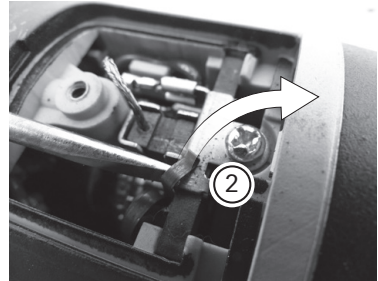
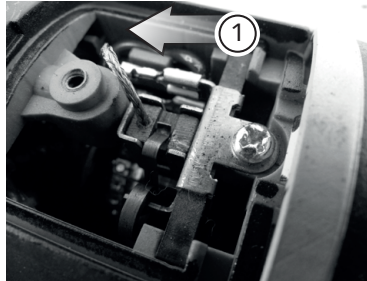
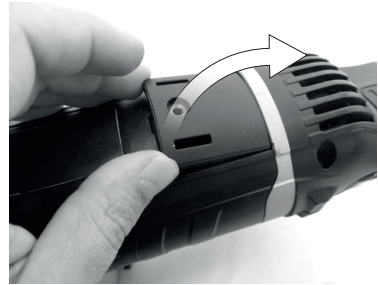
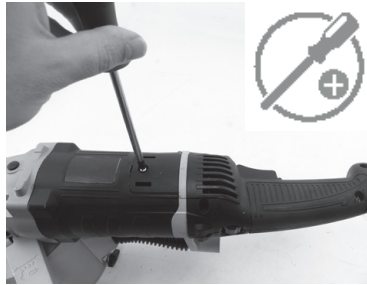



Toujours éloigner le câble d'alimentation de la brosse pour le stockage

Bewaar de stroomkabel altijd weg van de borstel voor opslag













Siempre aleje el cable de alimentación del cepillo para su almacenamiento

Sempre mova o cabo de alimentação para longe do pincel para armazenamento

Allontanare sempre il cavo di alimentazione dalla spazzola per la conservazione

Always move away the power cable from the brush during storage



<p>EnergyBrush-1500 150610 S1P-HJ2215HD-REAC</p>		<p>Rénovateur extérieur Exterior renovator Fuera renovador Fora renovador Restauratore di fuori Buiten renovator</p>	
	<p>Tension et fréquence assignée: Aangewezen spanning en frequentie: Tensión y frecuencia fijada: Tensão e frequência fixa: Tensione e frequenza assegnata: Nominal frequency and power:</p>	<p>230 V ~ 50 Hz</p>	
	<p>Puissance assignée: Onbelast toerental: Potencia fijada: Potência assinada: Potenza assegnata: Nominal power:</p>	<p>S1 SERVICE CONTINU Fonctionnement à charge constante pour atteindre l'équilibre thermique.</p>	<p>1500 W - S1</p>
	<p>Vitesse à vide: Leerlaufdrehzahl: Velocidad vacía: Velocità a vuoto: Velocidade no vácuo: No-load speed:</p>	<p>600-3200 min⁻¹</p>	
	<p>Diamètre et largeur de brosse : Diameter and width of wheel : Cepillar diámetro y anchura: Escovar diâmetro e largura: Spennellare diametro e larghezza: Borstel diameter en breedte:</p>	<p>120 x 100 I M8</p>	
	<p>Classe d'isolement : 2 Isolatie Klasse : 2 Aislamiento clase : 2 Isolamento classe : 2 Isolamento classe : 2 Insulation class : 2</p>	<p>X</p>	
	<p>Usage intérieur uniquement Indoor Use Only Alleen binnenshuis gebruik Sólo uso en interiores Apenas para uso interno Solo uso interno</p>	<p>X</p>	
<p>IP 20</p>		<p>X</p>	
	<p>Lire les instructions avant usage : Lees voor het gebruik de instructies : Léase las instrucciones antes de usar : Ler as instruções antes da utilização : Leggere le istruzioni prima dell'uso : Read the instructions before use :</p>	<p>X</p>	
	<p>Porter des lunettes de sécurité : Draag een veiligheidsbril : Llevar puestas gafas protectoras : Portare de gli occhiali di sicurezza : Utilizar óculos de segurança : Wear protective eyewear :</p>	<p>X</p>	
	<p>Porter un masque anti-poussière: Draag een stofmasker : Llevar puesta una careta de protección contra el polvo : Indossare una mascherina anti-polvere : Utilizar uma máscara anti-poeira : Wear a dust mask :</p>	<p>X</p>	
	<p>Porter une protection auditive: Draag gehoorbeschermers: Llevar puesta una protección auditiva: Portare una protezione uditiva: Utilizar uma protecção auditiva: Wear hearing protective equipment:</p>	<p>X</p>	
	<p>Porter des gants : Draag handschoenen: Usar guantes Indossare i guanti: Usar luvas: Wear gloves :</p>	<p>X</p>	
	<p>Conformité européenne : Voldoet aan de EG-normen : Cumple con las directivas CE : Conforme às normas CE : Conforme alle norme CE : Conforms to EC standards :</p>	<p>X</p>	
	<p>Danger : Gevaar : Peligro : Perigo : Pericolo : Danger :</p>	<p>X</p>	

	Poids :	5,75 kg
	Gewicht :	
	Peso :	
	Peso :	
	Peso :	
	Weight :	

	Recyclable, soumis au tri sélectif :	X
	Recyclable, subject to recycling:	
	Recyclebaar, onder voorbehoud van het sorteren:	
	Reciclabile, sin perjuicio de la clasificación:	
	Reciclável, sujeito a triagem:	
	Riciclabile, soggetto a cernita:	

	Soumis à recyclage :	X
	Niet wegwerpen :	
	Sottoposti a riciclaggio :	
	Sujeitos à reciclagem :	
	Sottoposti a riciclaggio :	
	Subjected to recycling :	

FR-Recyclage des déchets:

Les outils, accessoires et leur emballages doivent suivre une voie de recyclage adaptée. Conformément aux directives Européenne 2012/19/UE et 2006/66/CE, les composants d'un produit doivent être séparés, collectés, recyclés ou éliminés en conformité avec les réglementations environnementales en vigueur. Les appareils, batteries, piles, huiles, emballages devront être déposés dans les systèmes d'élimination des déchets spéciaux tels que déchetteries. Renseignez vous auprès de votre commune pour connaître l'organisme le plus proche à même de retraiter ou de collecter ces déchets.

 L_{pA}	Niveau de pression acoustique :	79 dB (A)
	Niveau akoestische druk :	
	Nível de presión acústica :	
	Nível de pressão acústica :	
	Livello di pressione acustica :	
	Acoustic pressure level :	

 L_{wA}	Niveau de puissance acoustique :	90 dB (A)
	Niveau akoestisch vermogen :	
	Nível de potencia acústica :	
	Nível de potência acústica:	
	Livello di potenza acustica:	
	Acoustic power level :	

NIVEAU SONORE D'ÉMISSION : A VIDE

Pression acoustique L_{pA} poste opérateur 79 dB
Incertitude 3

Puissance acoustique L_{wA} 90 dB
Incertitude 3

Valeurs déterminées suivant le code d'essai de l'annexe B de la norme EN 62841-1 avec emploi des normes de base ISO 11201 et ISO 3744.

Les niveaux de pression acoustique obtenus in situ dépendent :

- Des niveaux réels de la machine considérées, en prenant en compte les incertitudes déclarées.
- Du local et de l'installation de la machine. Préférez une pièce dont l'acoustique est plus feutrée. Evitez les pièces vide à grande résonance. Placez vous auprès d'une fenêtre le cas échéant.
- Des outils montés, des pièces travaillées, des réglages choisis,...

Niveau de vibration :	Trillingsniveau hand/arm :	3,88 m / s ²
	Nível de vibración mano/brazo :	
	Nível de vibração mão/braço :	
	Livello di vibrazione mano/braccio :	
	Hand/arm vibration level :	

VIBRATIONS :

Total des valeurs de vibration (somme vectorielle des trois directions) déterminée selon EN 60745 :

ah 3,88 m/s²
Incertitude K 1,5 m/s²

L'amplitude d'oscillation peut être utilisée comme valeur de comparaison d'outils électroportatifs.

Attention : si l'outil électroportatif est utilisé pour d'autres applications, avec d'autres outils de travail, l'amplitude d'oscillation peut être différente.

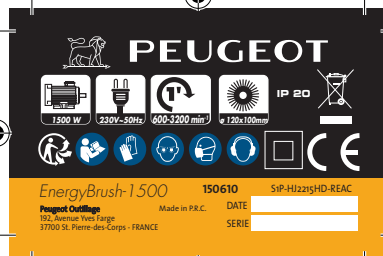

1 2 3 4 5 6

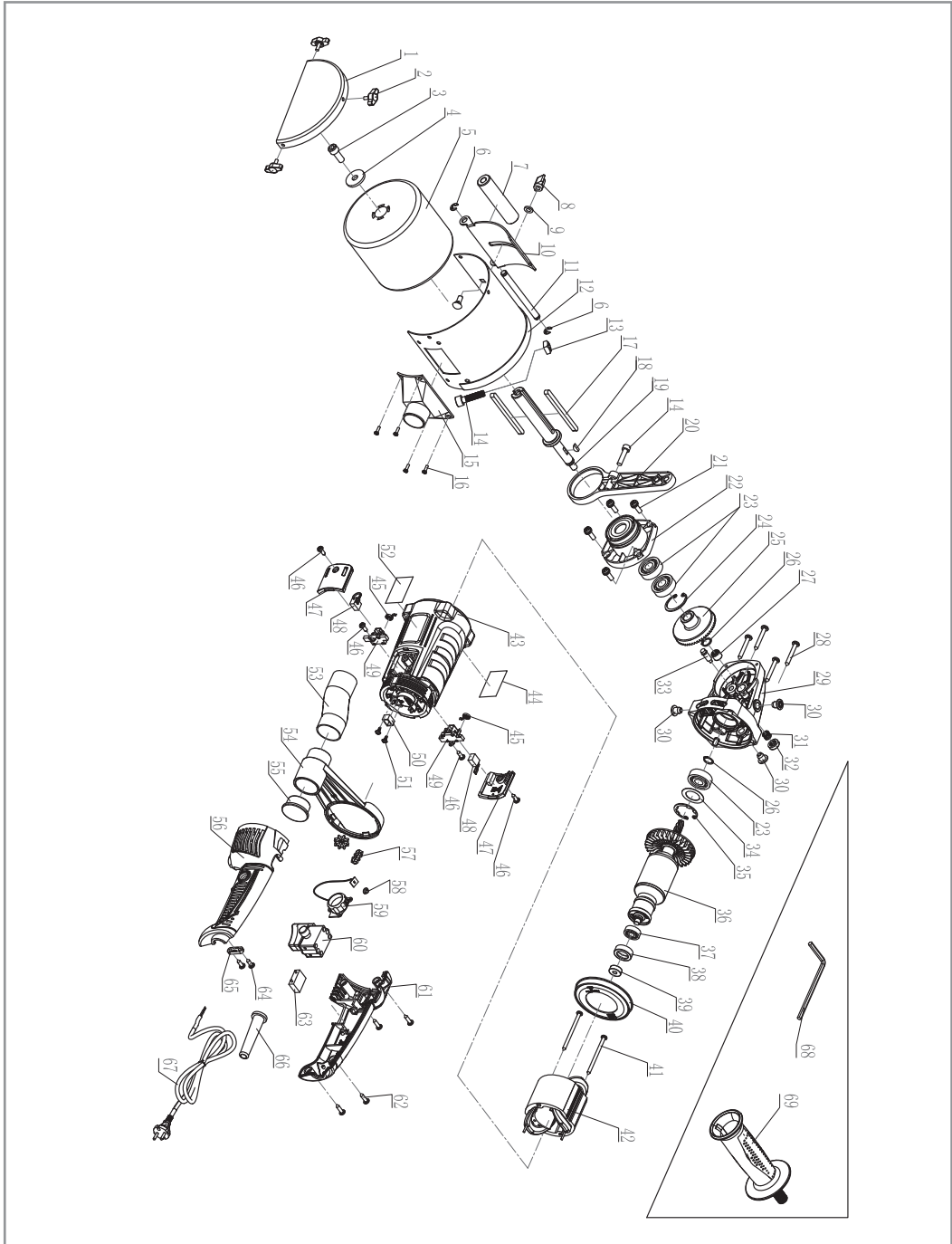



DECLARATION CE DE CONFORMITE
DECLARACION DE CONFORMIDAD
DICHIARAZIONE DI CONFORMITA

VERKLARING VAN OVEREENSTEMMING
DECLARAÇÃO DE CONFORMIDADE
DECLARATION OF CE CONFORMITY

Le soussigné,
Ondergetekende,
El suscrito,
O abaixo assinado,
Il sottoscritto,
The undersigned,

PEUGEOT OUTILLAGE

192, Avenue Yves Farge - 37700 St. Pierre-des-Corps - FRANCE
Tél. : 02 36 16 71 46 - Fax : 02 36 16 71 40

Déclare par la présente que,
Verklaart hiermede dat,
Declaro por la presente que,
Declara pela presente que,
Dichiare che,
Declares that,

CODE

PEUGEOT / EnergyBrush-1500 / 150610 / S1P-HJ2215HD-REAC

Rénovateur extérieur / Exterior renovator / Fuera renovador /
Fora renovador / Restauratore di fuori / Buiten renovator

Est conforme et satisfait aux normes CE:
In overeenstemming is met en Voldoet aan EG richtlijnen:
Cumple con la directivas de la CE:
Respeita e está em conformidade com as normas CE:
È conforme alle direttive CEE:
Complies with the EEC standards:



2006/42/EC 2014/30/EU 2011/65/EU

EN60745-1:2009+A11:2010
EN60745-2-3:2011+A2:2013+A11:2014+A12:2014 +A13:2015
EN55014-1:2021
EN55014-2:2021
EN61000-3-2:2019+A1:2021
EN61000-3-3:2013+A1:2019

SIGMA
Présidente de PEUGEOT OUTILLAGE
Représentée par son Président :
Christophe HUREL
08/06/2022
Fait à St. Pierre-des-Corps

Personne autorisée à
constituer le dossier technique :
Christophe HUREL



BON DE GARANTIE

1 - Objet de la garantie :
La garantie porte exclusivement sur les vices de fabrication ou les vices de matières.
Elle nous oblige à l'échange ou à la réparation des pièces reconnues hors d'usage.

2 - Durée de la garantie :
La garantie est de 36 mois à dater de la livraison du matériel à l'utilisateur (facture ou ticket de caisse à fournir).
Les échanges ou réparations faites au titre de la garantie ne peuvent avoir pour effet de prolonger celle-ci.
Les frais de port ALLER sont à la charge de l'utilisateur.

3 - Réserves :
La garantie ne s'applique en aucun cas aux réparations effectuées en dehors de nos réparateurs agréés.
En aucun cas, durant la période de garantie, le matériel ne devra être démonté.

GARANTIEKAART

1 - Doel van de garantie:
De garantie heeft uitsluitend betrekking op fabricagefouten of gebreken in materialen.
Het dwingt ons om uit te wisselen of reparatie van erkende onbruikbare onderdelen.

2 - Duur van de garantie:
De garantie bedraagt 36 maanden vanaf de levering van apparatuur voor de gebruiker (factuur of kassabon te verstrekken).
De uitwisseling of reparaties onder garantie niet te verlengen.
GO verzendkosten zijn voor rekening van de gebruiker.

3 - Reserves:
De garantie geldt niet in alle reparaties die buiten onze goedgekeurd reparateurs.
In ieder geval gedurende de garantie, moet het materiaal worden verwijderd.

TARJETA DE GARANTÍA

1 - Objeto de la garantía:
La garantía sólo se referirán a los defectos de fabricación o defectos en los materiales.
Nos obliga a cambiar o reparación de las piezas fuera de servicio reconocido.

2 - Duración de la garantía:
La garantía es de 36 meses a partir de la entrega de equipos para el usuario (factura o recibo que se den).
Los intercambios o reparaciones bajo garantía no tendrá que prolongarse.
GO gastos de envío correrán a cargo del usuario.

3 - Reservas:
La garantía no se aplica en todas las reparaciones realizadas fuera de nuestros talleres de reparación autorizadas.
En cualquier caso, durante el periodo de garantía, el material debe ser removido.

CARTÃO DE GARANTIA

1 - Finalidade da garantia:
A garantia só relacionar com defeitos de fabricação ou defeitos em materiais.
Ela nos obriga a troca ou reparo de peças inservíveis reconhecidos.

2 - Duração da Garantia:
A garantia é de 36 meses a partir da entrega de equipamentos para o usuário (factura ou recibo a ser fornecido). Trocas ou reparos sob a garantia não terá que prorrogá-la.
GO porte serão custeadas pelo usuário.

3 - Reservas:
A garantia não se aplica a quaisquer reparos feitos fora das nossas oficinas aprovadas.
Em qualquer caso, durante o período de garantia, o material deve ser removido.

GARANZIA

1 - Oggetto della garanzia:
La garanzia si riferisce esclusivamente alla difetti di fabbricazione o difetti nei materiali.
Ci costringe a scambio o la riparazione di parti inutilizzabili riconosciuti.

2 - Durata della garanzia:
La garanzia è di 36 mesi dalla consegna delle attrezzature per l'utente (fattura o ricevuta da fornire).
Scambi o riparazioni in garanzia non sarà necessario prolungarla.
GO spese di spedizione sono a carico dell'utente.

3 - Reserve:
La garanzia non si applica in tutte le riparazioni effettuate al di fuori dei nostri riparatori autorizzati.
In ogni caso, durante il periodo di garanzia, il materiale deve essere rimosso.

WARRANTY

1 - Scope of the warranty :
The warranty shall only apply to manufacturing defects or material defects.
We are obliged to exchange or repair parts that are identified as being unusable

2 - Lifetime warranty :
The warranty shall be valid for 36 months from the delivery date of the equipment to the user (invoice or till receipt must be provided).
Exchanges or repairs carried out under the warranty shall not extend the original warranty period.
The user shall be responsible for original shipping charges.

3 - Reservations :
Repairs shall not under any circumstances cover repairs carried out by a non-authorized repairer.
The equipment should not be dismantled under any circumstances during the warranty period.

Date d'achat	Référence machine	Cachet du distributeur
Datum van aankoop	Machine referentie	Dealer stempel
Fecha de compra	Referencia de la máquina	Comerciante de sellos
Data da compra	Referência de máquina	Selo Revendedor
Data di acquisto	Riferimento macchina	Timbro del rivenditore
Purchase date	Machine code	Distributor's stamp

SERVICE APRÈS VENTE - AFTER SALE SERVICE

PEUGEOT OUTILLAGE - 192, Avenue Yves Farge - 37700 St. Pierre-des-Corps - FRANCE - Tél. : 02 36 16 71 46 - Fax : 02 36 16 71 40



PEUGEOT OUTILLAGE

Une société du groupe **SIGMA**

192, Avenue Yves Farge
37700 St. Pierre-des-Corps
FRANCE

peugeot-outillage.com

