

Installation Instruction

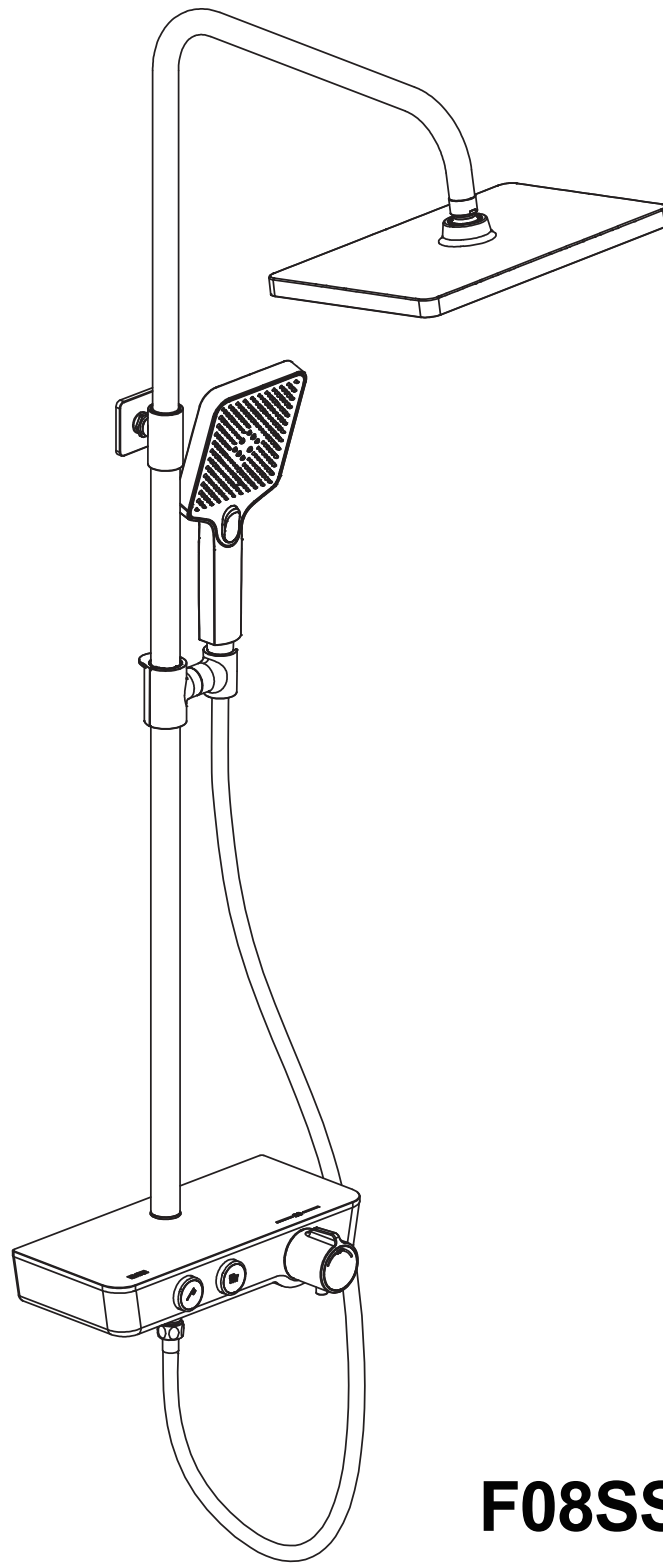

F08SSC00CP
F08SSC00GM

English / Deutsche / Français / Español / Italiano

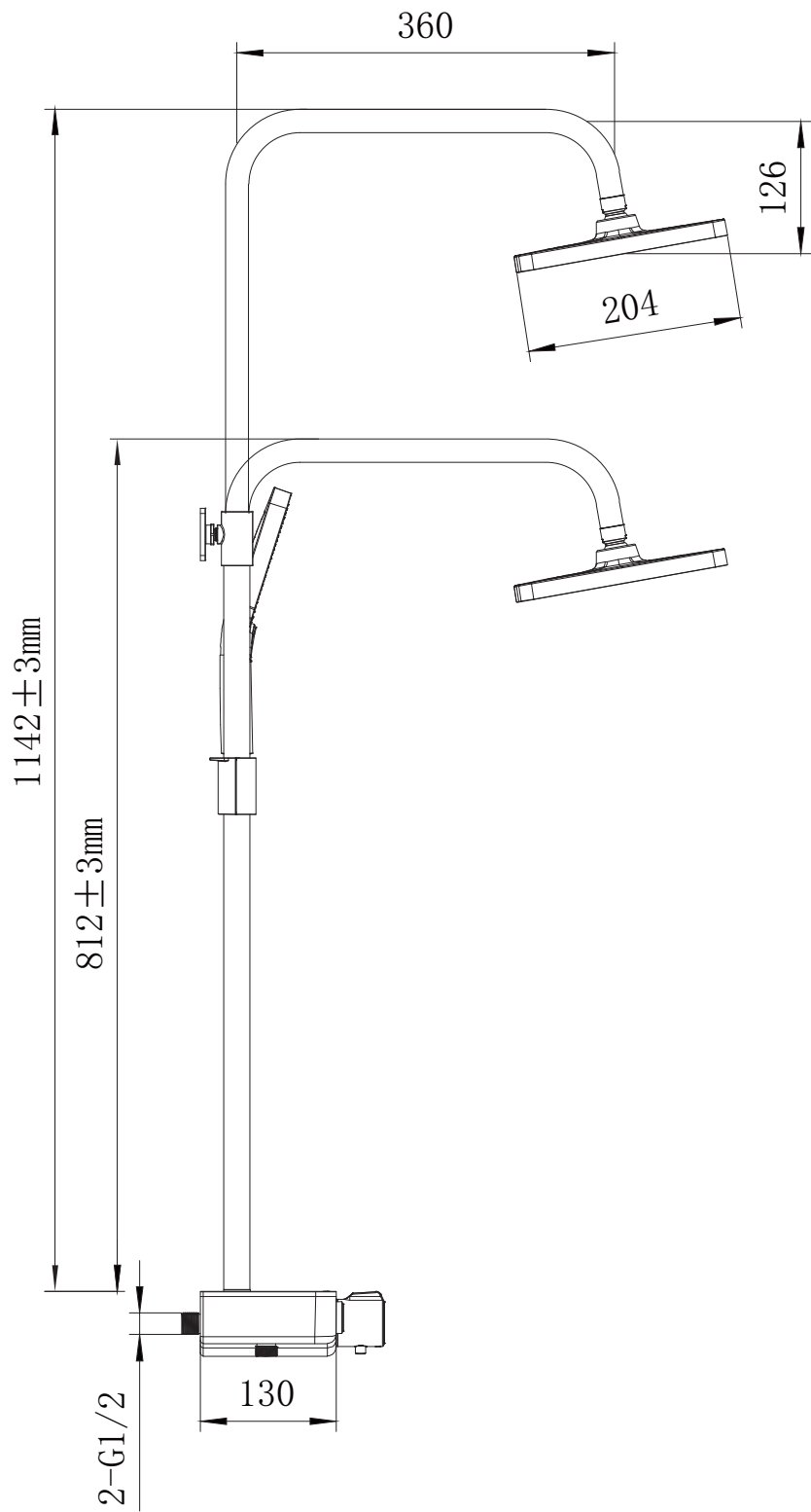
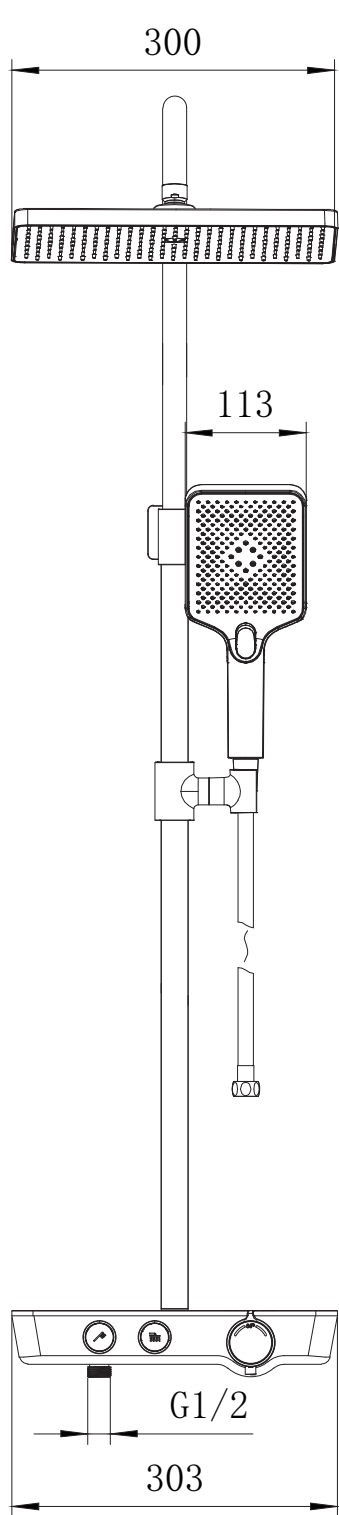

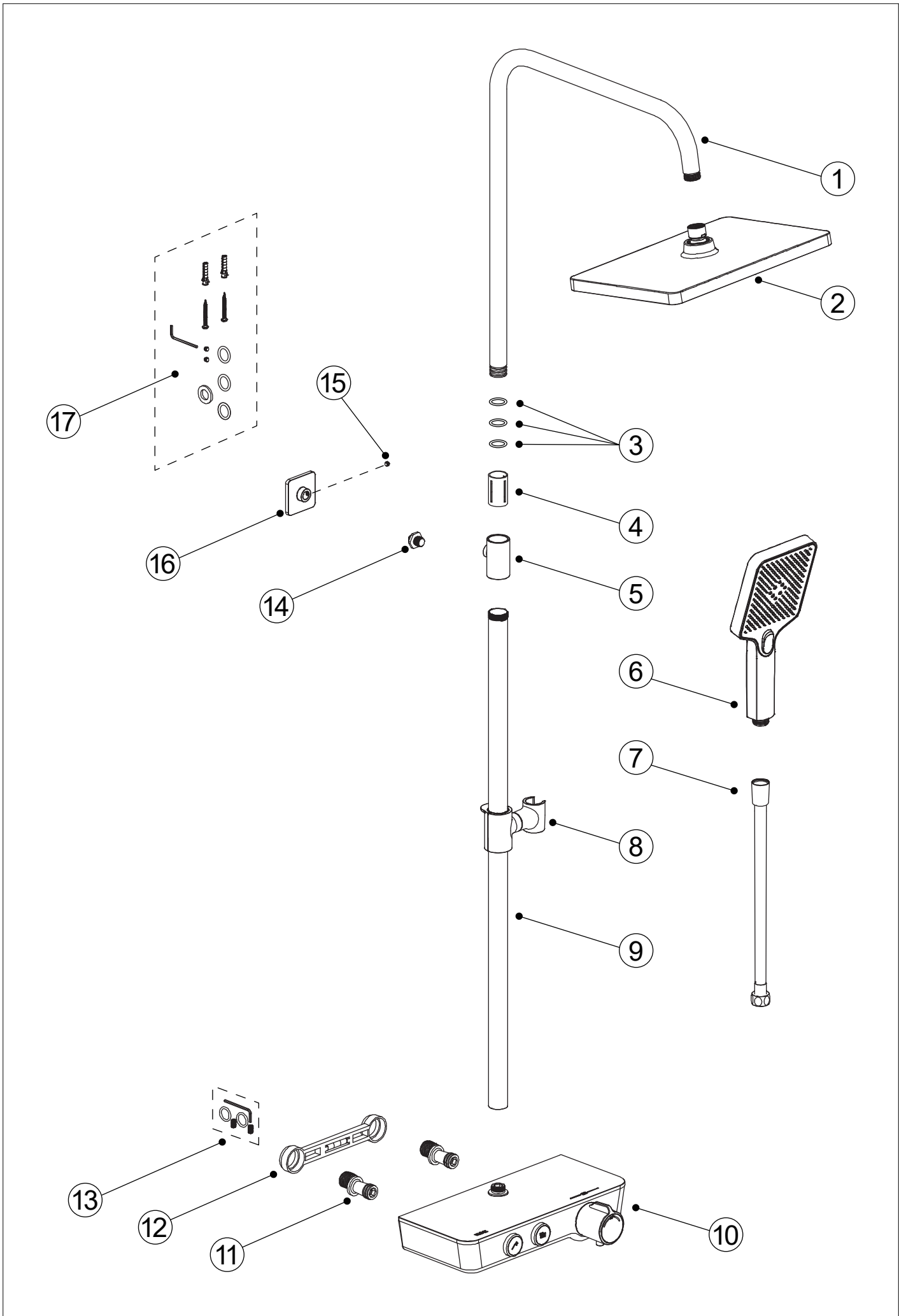

Step 1: Clean the water pipe and install the curved connector

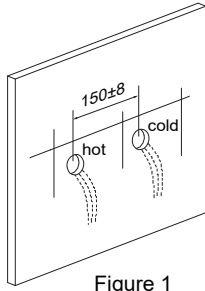

Figure 1

a) Run the water around 1-2 minutes to clean the water pipe (Figure 1).

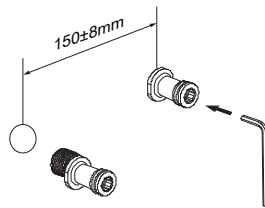

Figure 2

b) Wrap the teflon tape anticlockwise on the thread of the G1/2 end of the curved connector ⑪, connect them to the hot and cold water outlets by a wrench. Leave suitable depth out of the wall and adjust the distance between 2 connectors according to the width of the inlet on the thermostatic shower bar (Figure 2).

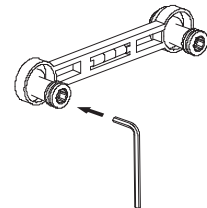

Figure 3

c) Make sure the 2 curved connectors are installed dead straight into the wall. The centre distance between 2 curved connectors is $150\pm 8\text{mm}$. Use the spirit level ⑫ to make sure the centre line remains horizontal (Figure 3).

Step 2: Install the thermostatic shower bar

a) Connect the thermostatic shower bar ⑩ onto the curved connectors (Figure 4). Left side is hot water and right side is cold water. Use the Allen key to secure.

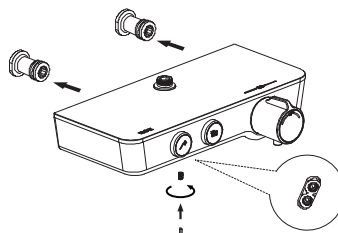

Figure 4

Step 3: Assemble the pipe for the shower head

a) Connect the raiser rail to the thermostatic shower bar (Figure 5/6) and mark the position of the pipe connector on the wall (Figure 7).

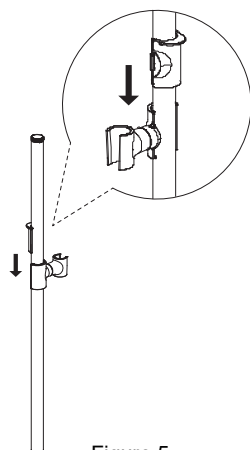

Figure 5

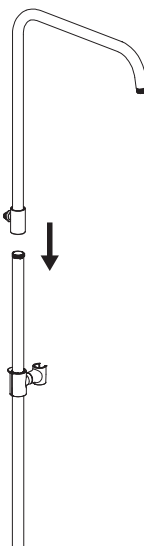

Figure 6

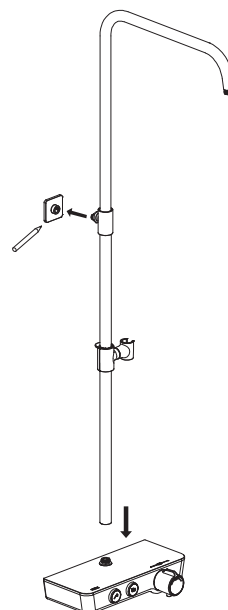

Figure 7

b) Install the wall holder ⑯ on the marked position (Figure 8). Cover the thermostatic shower bar to prevent the dust. Connect the pipe connector ⑤ to the wall holder and use the Allen key to secure (Figure 9).

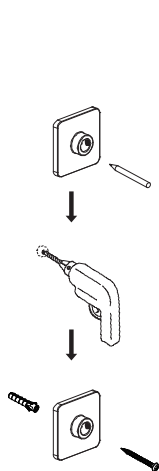

Figure 8

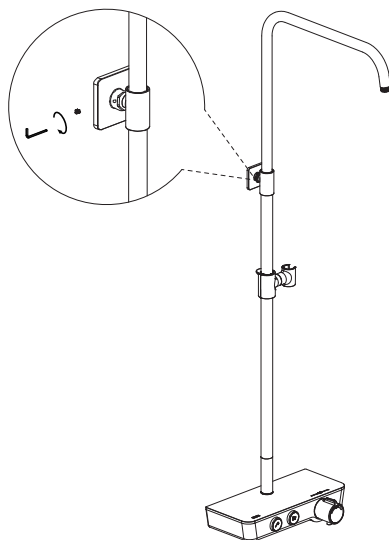
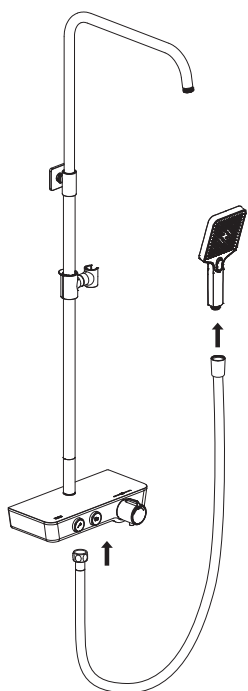
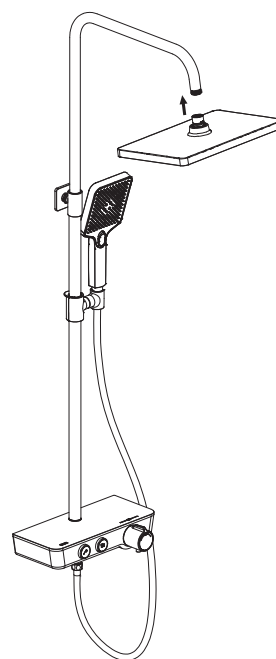

Figure 9

Step 4: Assemble the shower head (Make sure there is a washer inside of the shower head)



a) Connect the hose to the thermostatic shower bar and connect the shower head on the other end.



b) Connect the overhead shower to the arm pipe.

Function Guide:

A. Adjust the water temperature:

Press the button and turn the temperature knob left and right to increase and decrease the temperature.

B. Switch between the hand shower and overhead shower:

press the hand shower / overhead shower button.

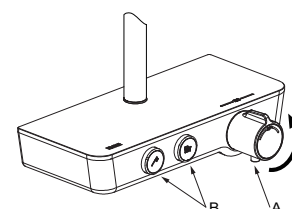

Schritt 1: Reinigen Sie die Wasserleitung und installieren Sie den gebogenen Anschluss



Abbildung 1

a) Lassen Sie das Wasser etwa 1-2 Minuten laufen, um die Wasserleitung zu reinigen (Abbildung 1).

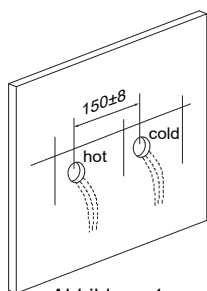

Abbildung 2

b) Wickeln Sie das Teflonband gegen den Uhrzeigersinn auf das Gewinde des G1/2"-Endes des gebogenen Anschlusses (11), verbinden Sie mit den Warm- und Kaltwasserauslässen mit einem Schraubenschlüssel. Lassen Sie eine angemessene Tiefe aus der Wand heraus und passen Sie den Abstand zwischen den 2 Anschlüssen entsprechend der Breite des Einlasses an der Thermostat-Duschstange an (Abbildung 2).

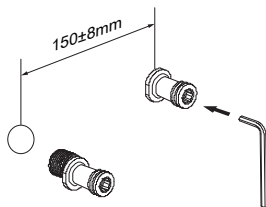

Abbildung 3

c) Vergewissern Sie sich, dass die 2 gebogenen Anschlüsse genau gerade in die Wand eingebaut sind. Der Achsabstand zwischen 2 gebogenen Anschlüssen beträgt 150 ± 8 mm. Verwenden Sie die Wasserwaage (12), um sicherzustellen, dass die Mittellinie horizontal bleibt (Abbildung 3).

Schritt 2: Installieren Sie die thermostatische Duschstange

a) Verbinden Sie die Thermostatbrausestange (10) mit den gebogenen Anschlüssen (Abbildung 4). Die linke Seite ist für Warmwasser und die rechte Seite für Kaltwasser. Verwenden Sie den Inbusschlüssel zum Befestigen.

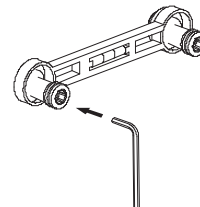

Abbildung 4

Schritt 3: Montieren Sie das Rohr für den Duschkopf

a) Verbinden Sie die Erhöhungsstange mit der Thermostat-Duschstange (Abbildung 5/6) und markieren Sie die Position des Rohranschlusses an der Wand (Abbildung 7).

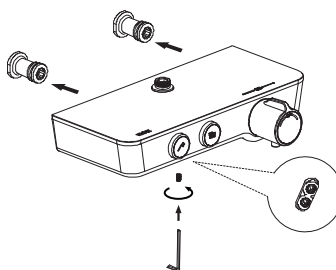

Abbildung 5



Abbildung 6

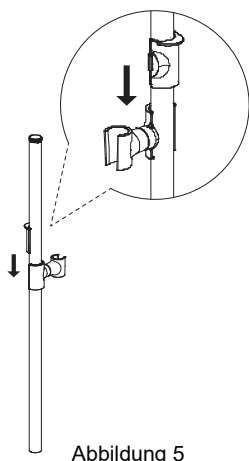

Abbildung 7

b) Montieren Sie die Wandhalterung 16 an der markierten Stelle (Abbildung 8). Decken Sie die thermostatische Duschstange ab, um Staub zu vermeiden. Verbinden Sie das Rohrverbindungsstück 5 mit dem Wandhalter und sichern Sie es mit dem Inbusschlüssel (Abbildung 9).

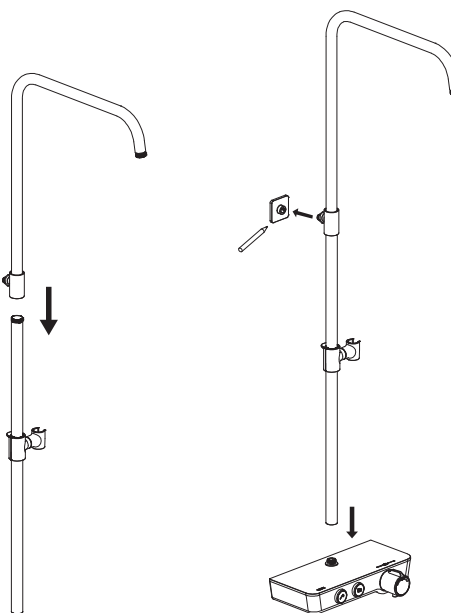

Abbildung 8

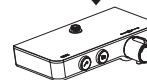

Abbildung 9

Schritt 4: Montieren Sie den Duschkopf (vergewissern Sie sich, dass sich eine Unterlegscheibe im Inneren des Duschkopfes befindet)

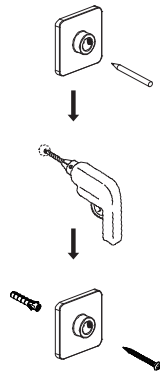

a) Verbinden Sie den Schlauch mit der Thermostatbrausestange und schließen Sie den Duschkopf am anderen Ende an.

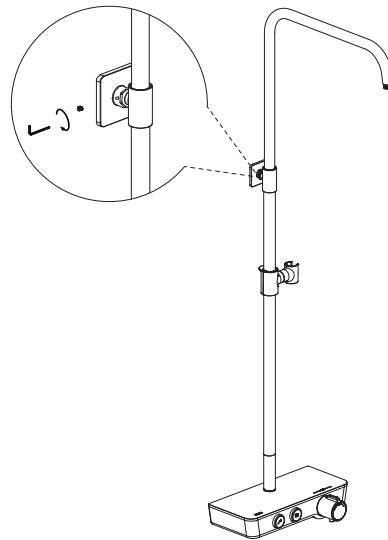
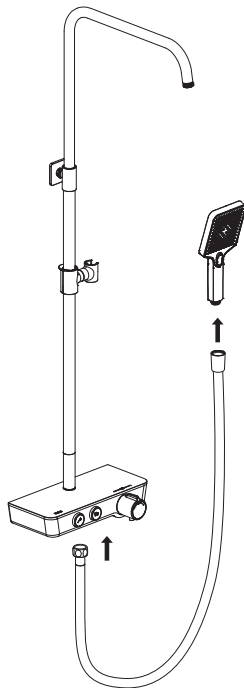
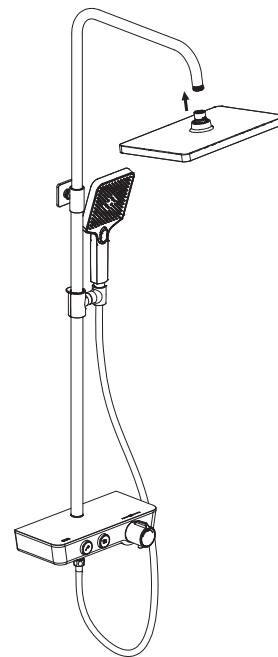

b) Schließen Sie die Kopfbrause an das Armrohr an.

Funktionsübersicht:

A. Stellen Sie die Wassertemperatur ein:

Drücken Sie die Taste und drehen Sie den Temperaturregler nach links und rechts, um die Temperatur zu erhöhen oder zu verringern.

B. zwischen Hand- und Kopfbrause umschalten:

Drücken Sie die Taste für die Handbrause / Kopfbrause.

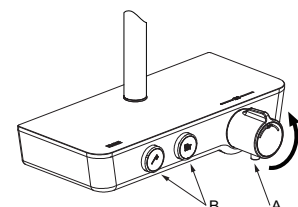

Étape 1 : Nettoyer le tuyau d'eau et installer le connecteur courbe

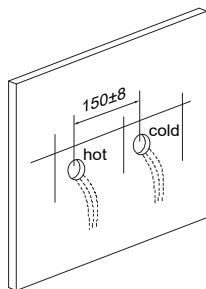

Figure 1

a) Faites couler l'eau pendant 1 à 2 minutes pour nettoyer le tuyau d'eau (Figure 1).

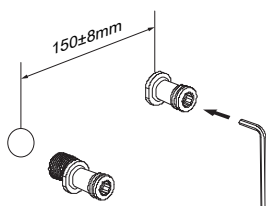

Figure 2

b) Enroulez le ruban téflon dans le sens inverse des aiguilles d'une montre sur le filetage de l'extrémité G1/2 du connecteur courbe (11), raccordez-les aux sorties d'eau chaude et froide à l'aide d'une clé. Laissez une profondeur appropriée hors du mur et ajustez la distance entre 2 connecteurs en fonction de la largeur de l'entrée de la barre de douche thermostatique (Figure 2).

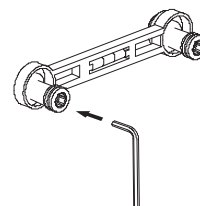

Figure 3

c) S'assurer que les 2 connecteurs courbes sont installés de manière parfaitement droite dans le mur. La distance centrale entre 2 connecteurs courbes est de 150±8mm. Utilisez le niveau à bulle (12) pour vous assurer que la ligne centrale reste horizontale (Figure 3).

Étape 2 : Installer la barre de douche thermostatique

a) Connectez la barre de douche thermostatique (10) sur les connecteurs courbes (Figure 4). Le côté gauche correspond à l'eau chaude et le côté droit à l'eau froide. Utilisez la clé Allen pour la fixer.

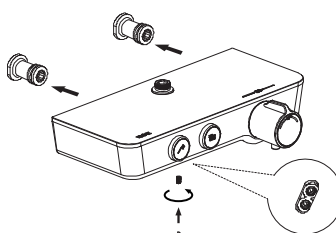

Figure 4

Étape 3 : Assemblage du tuyau pour la douchette

a) Raccordez la barre de relèvement à la barre de douche thermostatique (Figure 5/6) et marquez la position du raccord de tuyau sur le mur (Figure 7).

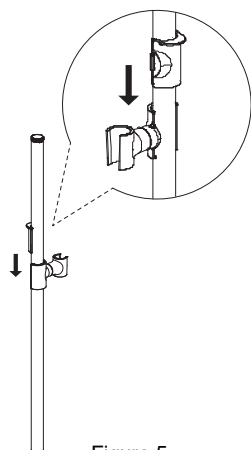

Figure 5

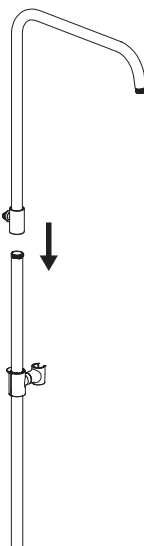

Figure 6

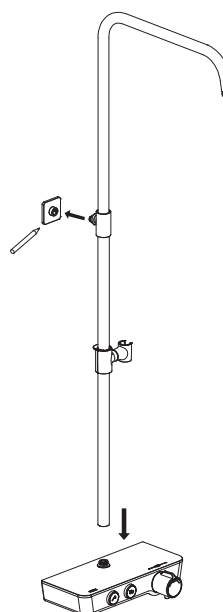

Figure 7

b) Installez le support mural (16) sur la position marquée (Figure 8). Couvrez la barre de douche thermostatique pour éviter la poussière. Connectez le raccord de tuyau (5) au support mural et utilisez la clé Allen pour le fixer (Figure 9).

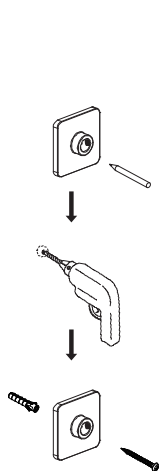

Figure 8

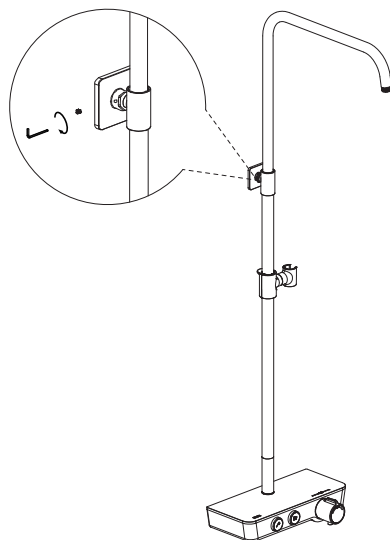
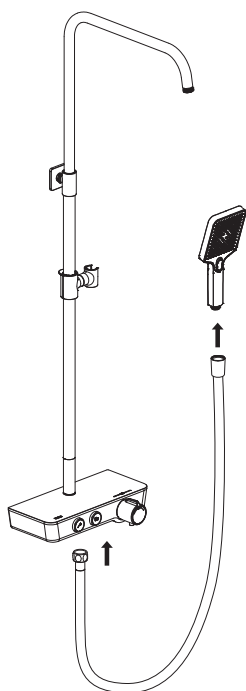
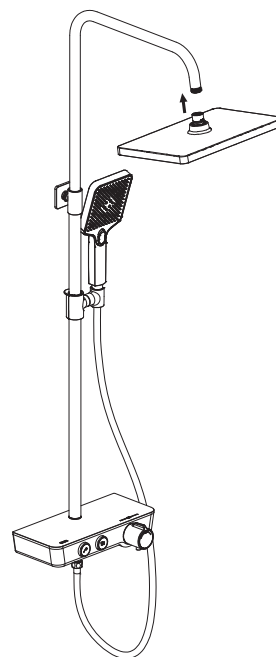

Figure 9

Étape 4 : Assembler la pomme de douche (Assurezvous qu'il y a une rondelle à l'intérieur de la pomme de douche)



a) Connectez le tuyau à la barre de douche thermostatique et connectez la pomme de douche à l'autre extrémité.



b) Raccordez la douche de tête au tuyau du bras.

Guide des fonctions:

A. Régler la température de l'eau:

Appuyez sur le bouton et tournez le bouton de température vers la gauche et la droite pour augmenter ou diminuer la température.

B. Passer de la douche à main à la douche de tête:

Appuyez sur le bouton de la douche à main / de la douche de tête.

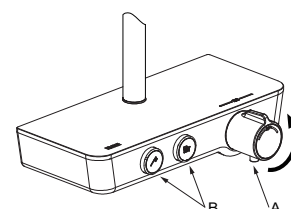

Paso 1: Limpiar la tubería de agua e instalar el conector curvo



Figura 1

a) Deje correr el agua alrededor de 1-2 minutos para limpiar la tubería de agua (Figura 1).

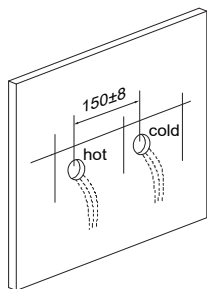

Figura 2

b) Envuelva la cinta de teflón en sentido contrario a las agujas del reloj en la rosca del extremo G1/2 del conector curvo (1), conéctelos a las salidas de agua caliente y fría con una llave. Deje una profundidad adecuada fuera de la pared y ajuste la distancia entre los 2 conectores según la anchura de la entrada en la barra de ducha termostática (Figura 2).

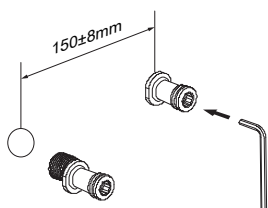

Figura 3

c) Asegúrese de que los 2 conectores curvos se instalan de forma totalmente recta en la pared. La distancia central entre los 2 conectores curvos es de 150±8mm. Utilice el nivel de burbuja (2) para asegurarse de que la línea central permanece horizontal (Figura 3).

Paso 2: Instalar la barra de ducha termostática

a) Conecte la barra de ducha termostática (10) en los conectores curvos (Figura 4). El lado izquierdo es de agua caliente y el derecho de agua fría. Utilice la llave Allen para asegurar.

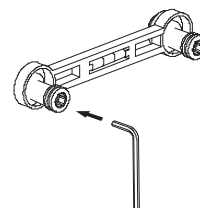

Figura 4

Paso 3: Montar la tubería para la alcachofa de la ducha

a) Conecte el rail elevador a la barra de ducha termostática (Figura 5/6) y marque la posición del conector del tubo en la pared (Figura 7).

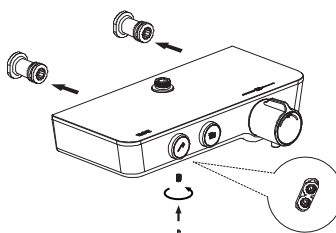

Figura 5



Figura 6

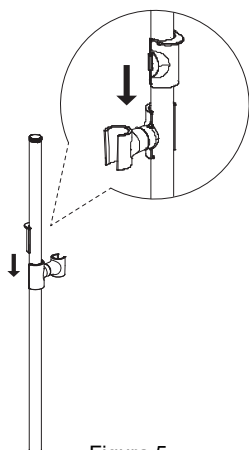

Figura 7

b) Instale el soporte de pared ⑯ en la posición marcada (Figura 8). Cubra la barra de ducha termostática para evitar el polvo. Conecte el conector de tubería ⑤ al soporte de pared y utilice la llave Allen para asegurarlo (Figura 9).

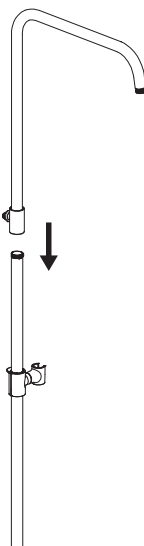

Figura 8

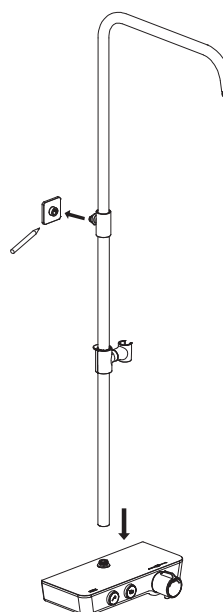

Figura 9

Paso 4: Montar la alcachofa de la ducha (Asegúrese de que hay una arandela dentro de la alcachofa de la ducha)

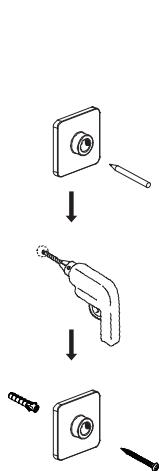

a) Conecte la manguera a la barra de ducha termostática y conecte la alcachofa de la ducha en el otro extremo.

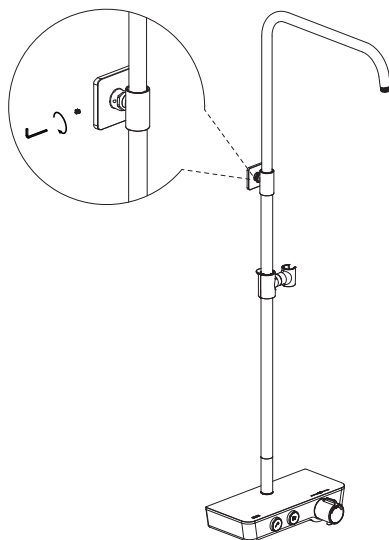
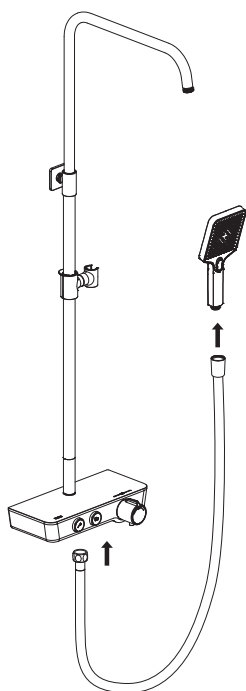
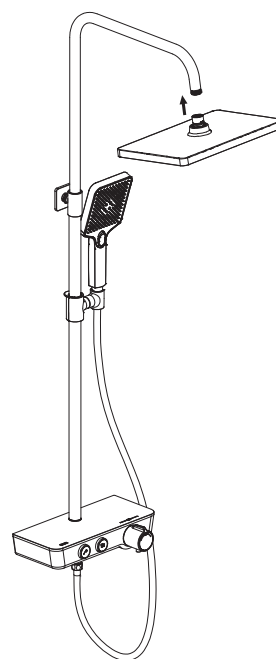

b) Conecte la ducha de techo al tubo del brazo.

Guía de funciones:

A. Ajuste la temperatura del agua:

Pulse el botón y gire el mando de la temperatura a la izquierda y a la derecha para aumentar y disminuir la temperatura.

B. Cambie entre la ducha de mano y la ducha superior:

pulse el botón de ducha de mano / ducha superior.

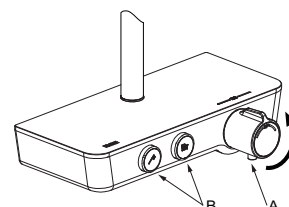

Fase 1: pulire il tubo dell'acqua e installare il connettore curvo



Figura 1

a) Far scorrere l'acqua per 1-2 minuti per pulire il tubo dell'acqua (Figura 1).

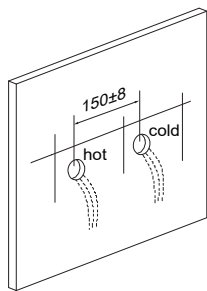

Figura 2

b) Avvolgere il nastro di teflon in senso antiorario sulla filettatura dell'estremità G1/2 del connettore curvo (11), collegarli alle uscite dell'acqua calda e fredda con una chiave. Lasciare una profondità adeguata dalla parete e regolare la distanza tra i 2 connettori in base alla larghezza dell'ingresso della barra termostatica della doccia (Figura 2).

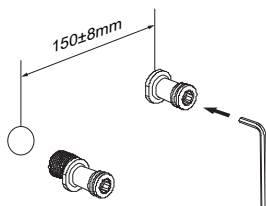

Figura 3

c) Assicurarsi che i 2 connettori curvi siano installati in modo mortalmente dritto nella parete. L'interasse tra i 2 connettori curvi è di 150±8 mm. Utilizzare la livella a bolla d'aria (12) per assicurarsi che la linea centrale rimanga orizzontale (Figura 3).

Fase 2: Installazione della barra termostatica della doccia

a) Collegare la barra termostatica della doccia (10) ai connettori curvi (Figura 4). Il lato sinistro è quello dell'acqua calda e il lato destro è quello dell'acqua fredda. Utilizzare la chiave a brugola per fissarla.

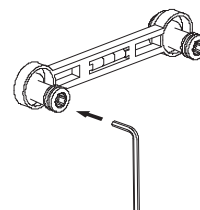

Figura 4

Fase 3: montaggio del tubo per il soffione doccia

a) Collegare la guida di rialzo alla barra termostatica della doccia (Figura 5/6) e segnare la posizione del connettore del tubo sulla parete (Figura 7).

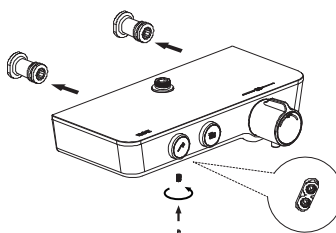

Figura 5



Figura 6

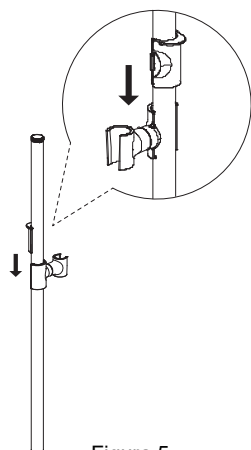

Figura 7

b) Installare il supporto a parete ⑬ nella posizione contrassegnata (Figura 8). Coprire la barra termostatica della doccia per evitare la polvere. Collegare il connettore del tubo ⑤ al supporto a parete e utilizzare la chiave a brugola per fissarlo (Figura 9).

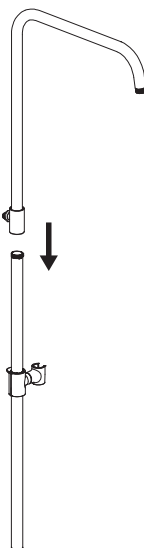

Figura 8

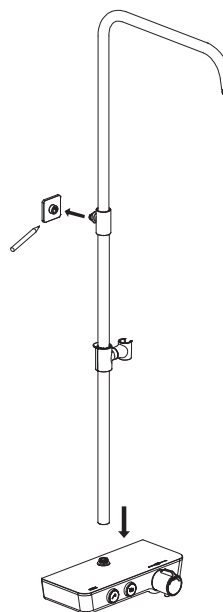

Figura 9

Fase 4: Assemblaggio del soffione (accertarsi della presenza di una rondella all'interno del soffione)

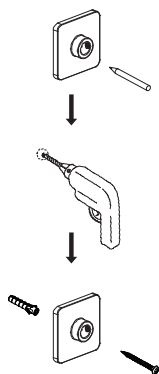

a) Collegare il tubo flessibile alla barra termostatica della doccia e collegare il soffione all'altra estremità .

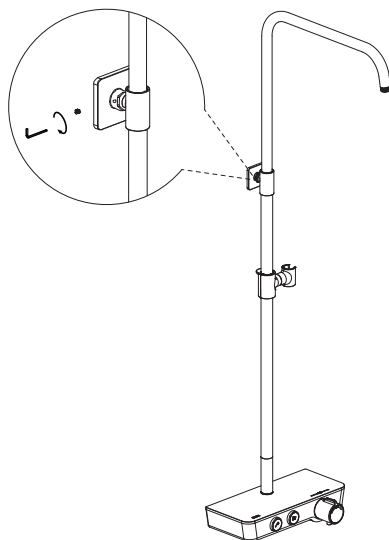
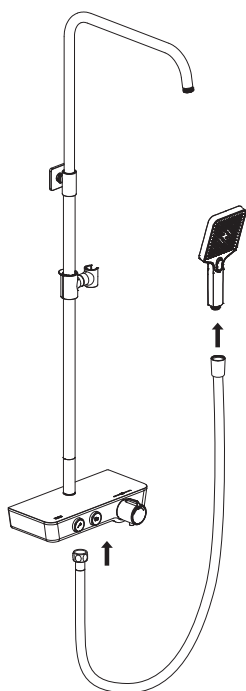
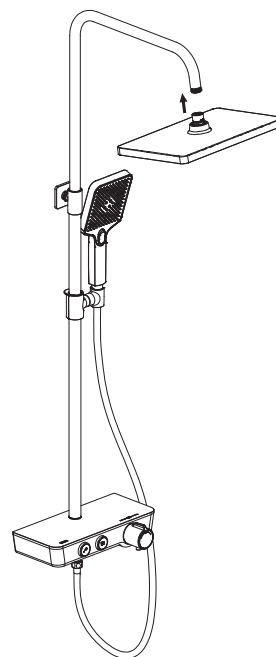

b) Collegare il soffione al tubo del braccio .

Guida alle funzioni:

A. Regolare la temperatura dell'acqua:

Premere il pulsante e ruotare la manopola della temperatura a sinistra e a destra per aumentare e diminuire la temperatura.

B. Passare dalla doccetta al soffione:

Premere il pulsante della doccetta/soffione.

