

Conçu selon DTU 36.3 et NF EN 15644 (classe de service 1 – trafic F1 – charge par marche maxi 200kg) .

AVANT MONTAGE

Vérifier le bon état et la présence de l'ensemble des pièces avant le montage. Ne pas modifier le produit.
À réception du produit, il convient de l'installer dans un environnement couvert et chauffé avec une humidité relative ne dépassant pas les 65%.

MONTAGE

Utiliser les cartons d'emballage pour protéger votre zone de travail. Respecter les règles de sécurité et le port des équipements de protection individuels (EPI), le principal risque encouru étant la chute. Eloigner les enfants lors du montage. Le montage d'un escalier n'est pas un acte anodin. Il doit être réalisé en respectant la notice de pose dans un environnement et avec des outils adéquats. Un minimum de 2 personnes est recommandé pour le montage.

FIXATION AU SOL

Pour éviter tout risque de basculement, ce produit doit être solidement fixé sur un sol plein, sec et fini. Eviter le contact avec des matériaux humides. Utiliser des vis et chevilles adaptées à votre support (non fournies, voir notice). Un montage mal effectué peut provoquer la chute du produit et des blessures graves.

ENTRETIEN

Vérifier la bonne tenue dans le temps des fixations au sol. Vérifier le bon état des composants, le serrage des assemblages et remplacer les composants dégradés. Nettoyer (1x/an) à l'eau claire avec un chiffon doux pour conserver l'aspect et la tenue à la corrosion. Ne pas utiliser des produits agressifs.

CLAUSE DE GARANTIE

Escalier à usage domestique intérieur dans un environnement couvert et chauffé avec une humidité relative ne dépassant pas les 65%.



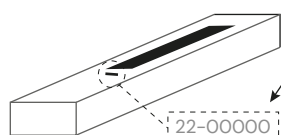



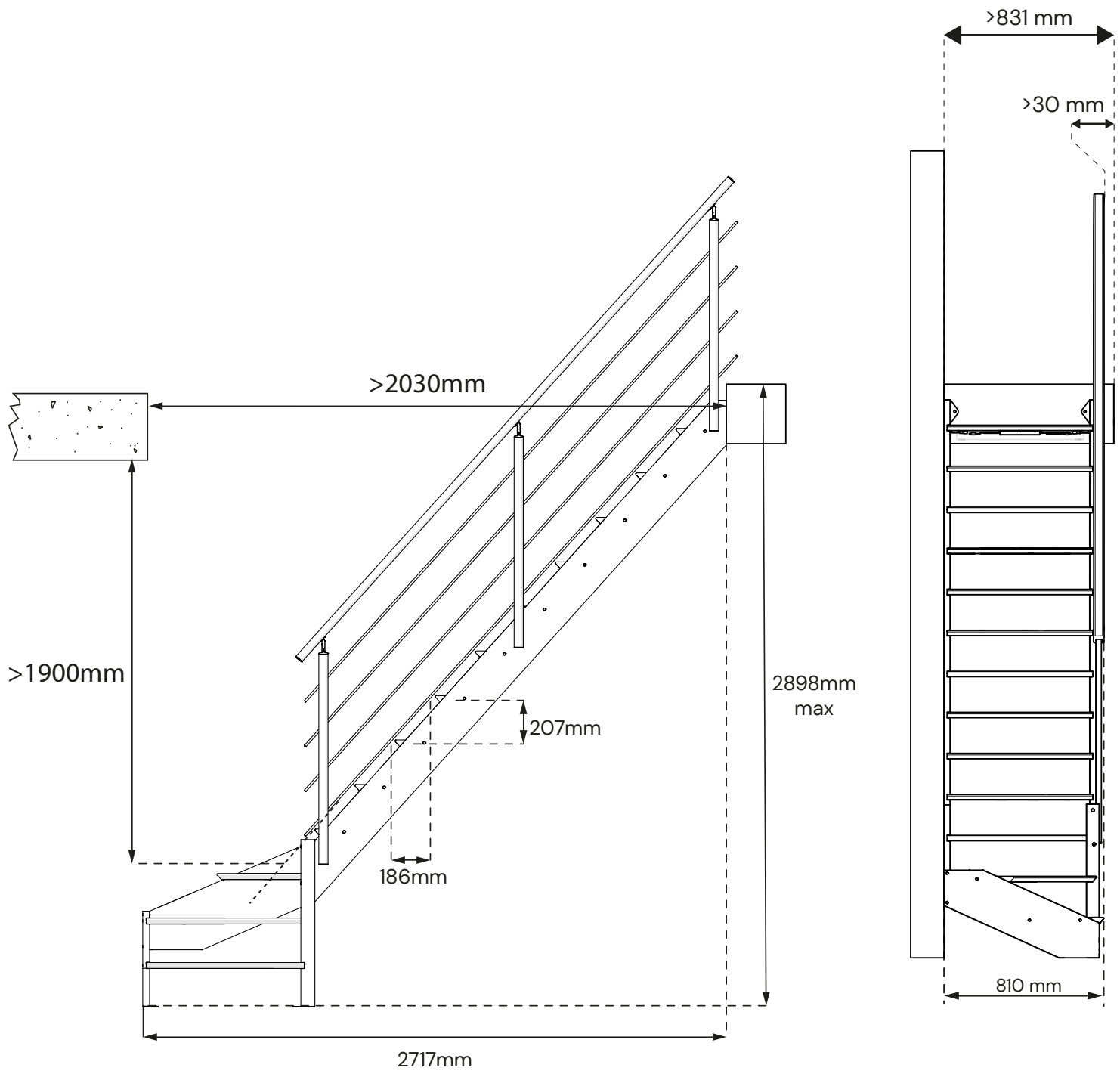
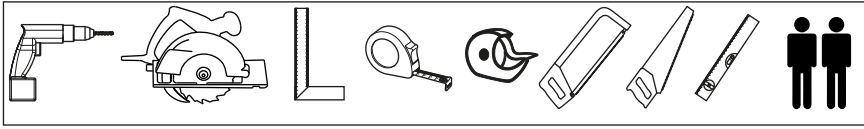

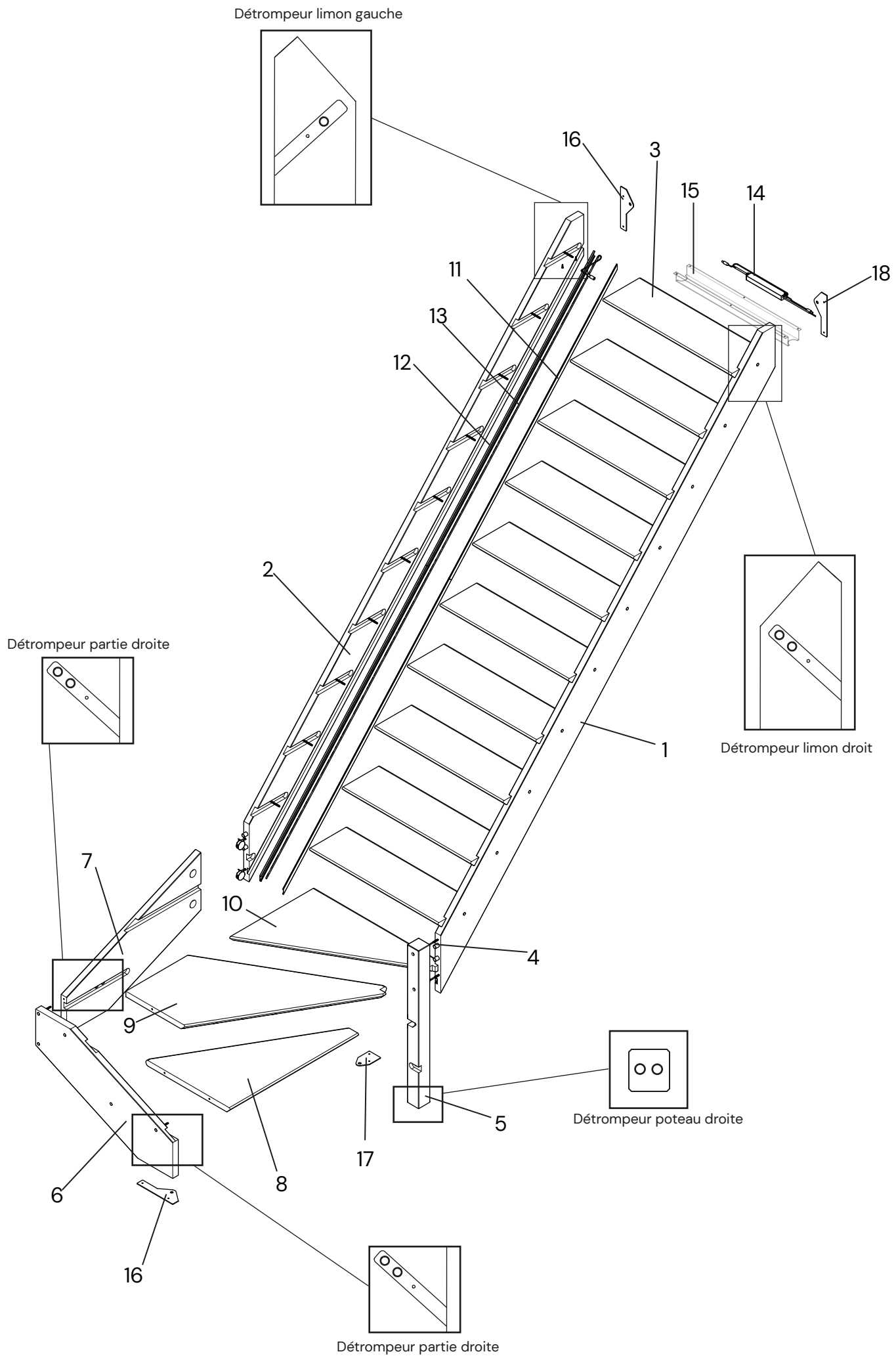

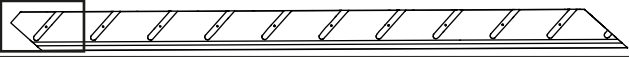
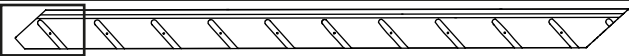
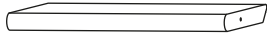
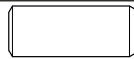
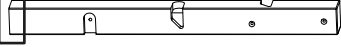
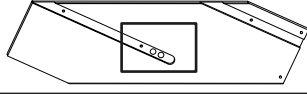
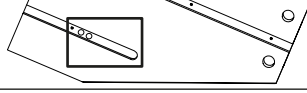
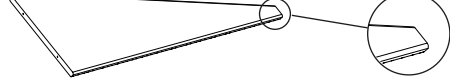

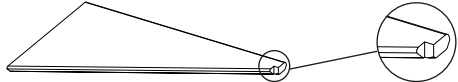
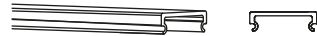

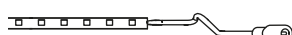
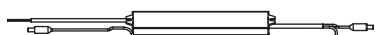

Notice et référence de traçabilité à conserver, nécessaire en cas de SAV.

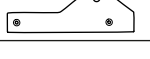

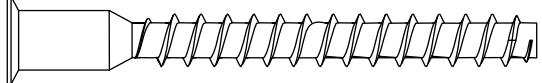
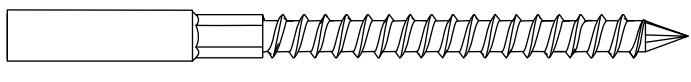
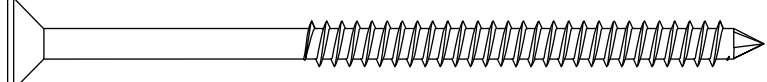
Référence à communiquer
pour toute demande.





1	22191	Détrompeur limon Droit		32x190x2916 mm	x1
2	22192	Détrompeur limon Gauche		32x190x2916 mm	x1
3	22125			27x220x735 mm	x10
4	72219			Ø16x40mm	x4
5	22195	Détrompeur poteau partie Droite		65x65x775 mm	x1
6	22196	Détrompeur limon partie Droite		32x245x897 mm	x1
7	22199	Détrompeur limon partie Droite		32x261x907 mm	x1
8	22136			27x482x735 mm	x1
9	22138			27x486x1019 mm	x1
10	22137			27x489x735 mm	x1
11	70243			5x17x1850 mm	x4
12	70242			8x17x1850 mm	x4
13	70244			5x8x4000 mm	x2
14	70244			21x29x221 mm	x1
15	70244			45x90x640mm	x1
16	70352			3x73x204 mm	x2
17	70848			3x65x103 mm	x1
18	70353			3x73x204 mm	x1
A	72031			Ø4x35 mm	x8
B	72532			Ø7x70 mm	x29
C	72533			Ø6x80 mm	x2
D	72066			Ø6x100 mm	x2
E	70244			Ø3x15 mm	x8
F	70849			Ø12 mm	x27
G	70850			Ø15 mm	x2
H	70841			Ø35 mm	x2
I	72760			Ø35 mm	x2
J	70841			M8	x2



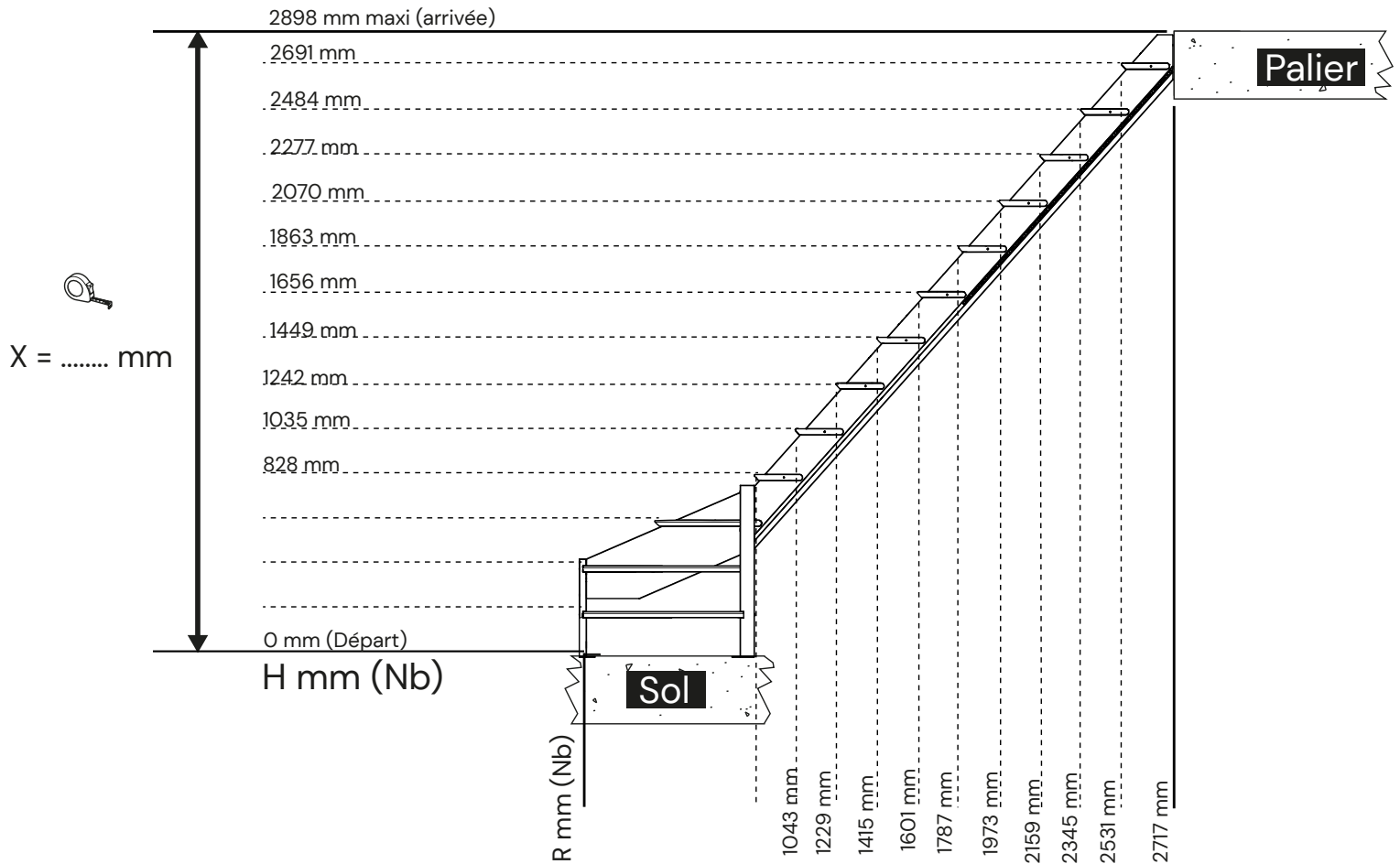

X (mm)	H (mm)
$2691 \leq X \leq 2898$	2691
$2484 \leq X \leq 2691$	2484
$2277 \leq X \leq 2484$	2277
$2070 \leq X \leq 2277$	2070
$1863 \leq X \leq 2070$	1863
$1656 \leq X \leq 1863$	1656
$1449 \leq X \leq 1656$	1449
$1242 \leq X \leq 1449$	1242
$1035 \leq X \leq 1242$	1035
$828 \leq X \leq 1035$	828

Nb: Nombre de marche

R(mm): Reculement de l'escalier en fonction du nombre de marche

H(mm): Hauteur du **Sol** jusqu'à la dernière marche

X(mm): Hauteur mesurée du **Sol** jusqu'au **Palier**

H (mm)	
2691	-
2484	9
2277	8
2070	7
1863	6
1656	5
1449	4
1242	3
1035	2
828	1

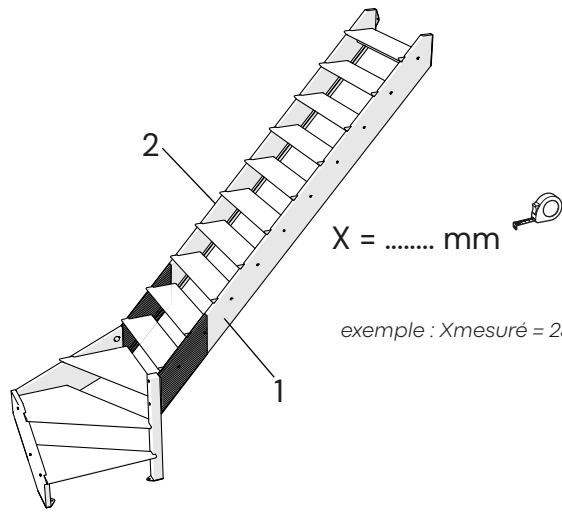

X (mm)	H (mm)	
$2691 \leq X \leq 2898$	2691	-
$2484 \leq X \leq 2691$	2484	9
$2277 \leq X \leq 2484$	2277	8
$2070 \leq X \leq 2277$	2070	7
$1863 \leq X \leq 2070$	1863	6
$1656 \leq X \leq 1863$	1656	5
$1449 \leq X \leq 1656$	1449	4
$1242 \leq X \leq 1449$	1242	3
$1035 \leq X \leq 1242$	1035	2
$828 \leq X \leq 1035$	828	1

H (mm) : hauteur du sol jusqu'à la dernière marche

Recouper à la position 8

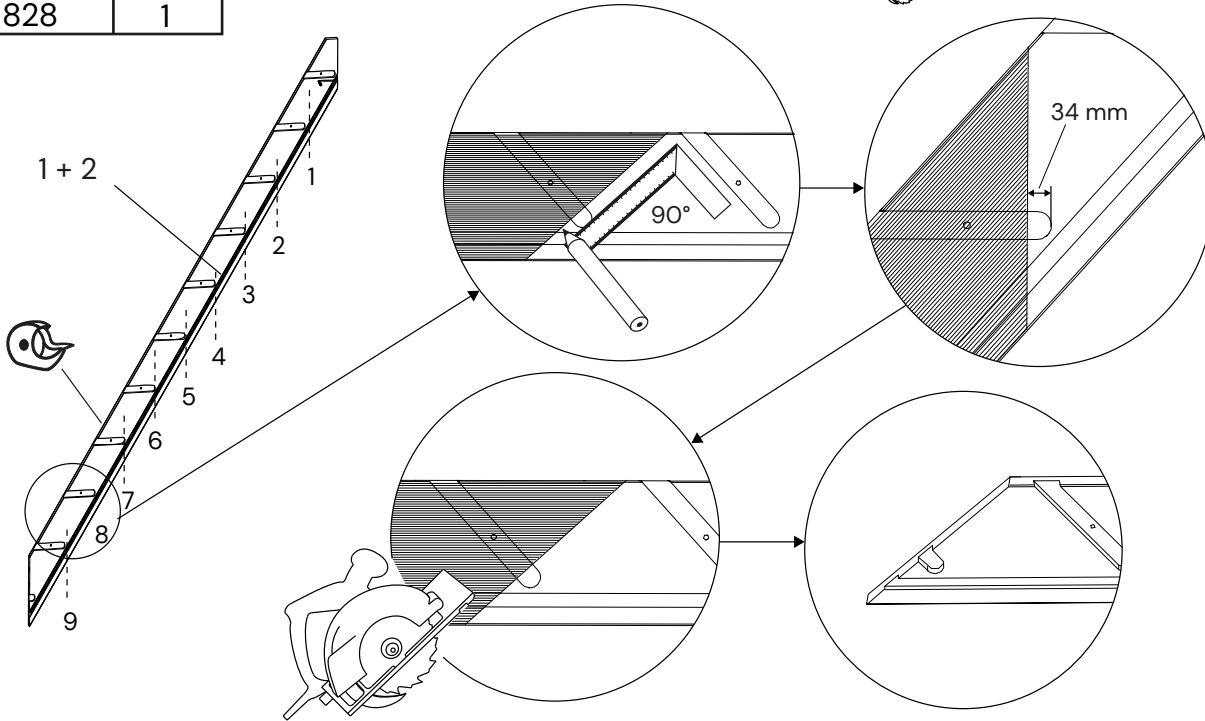

a

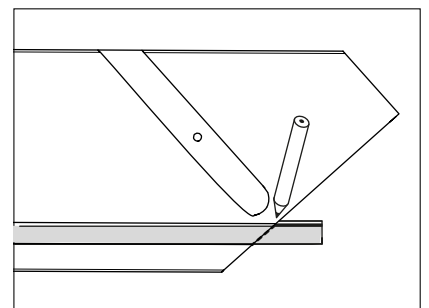
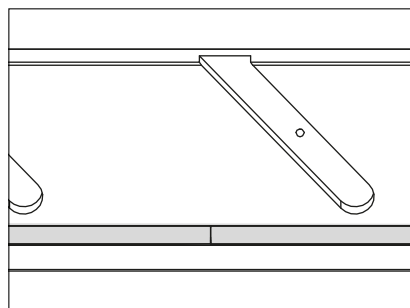
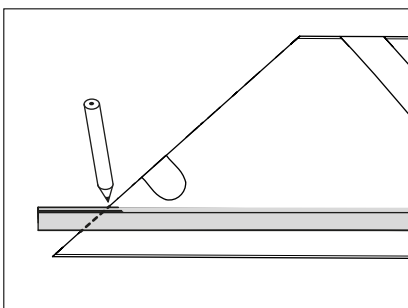
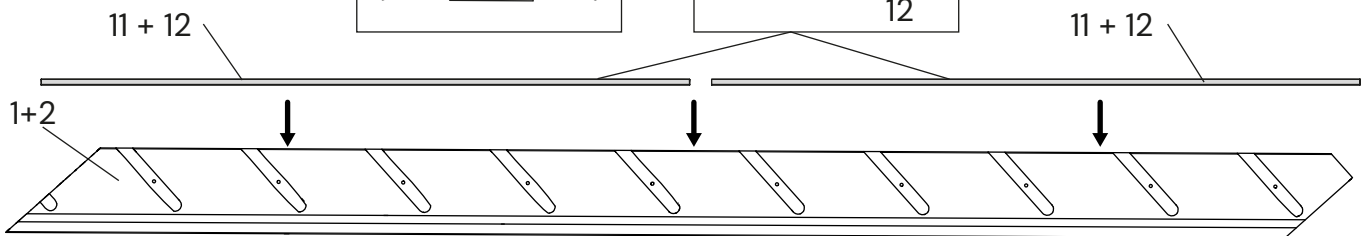
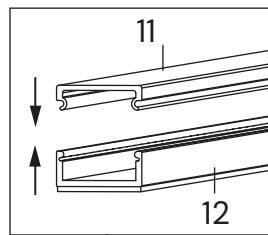
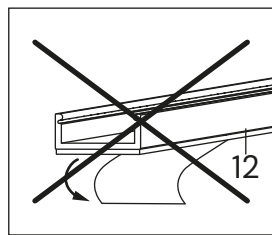
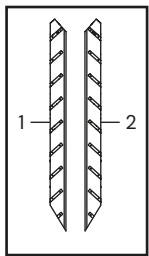

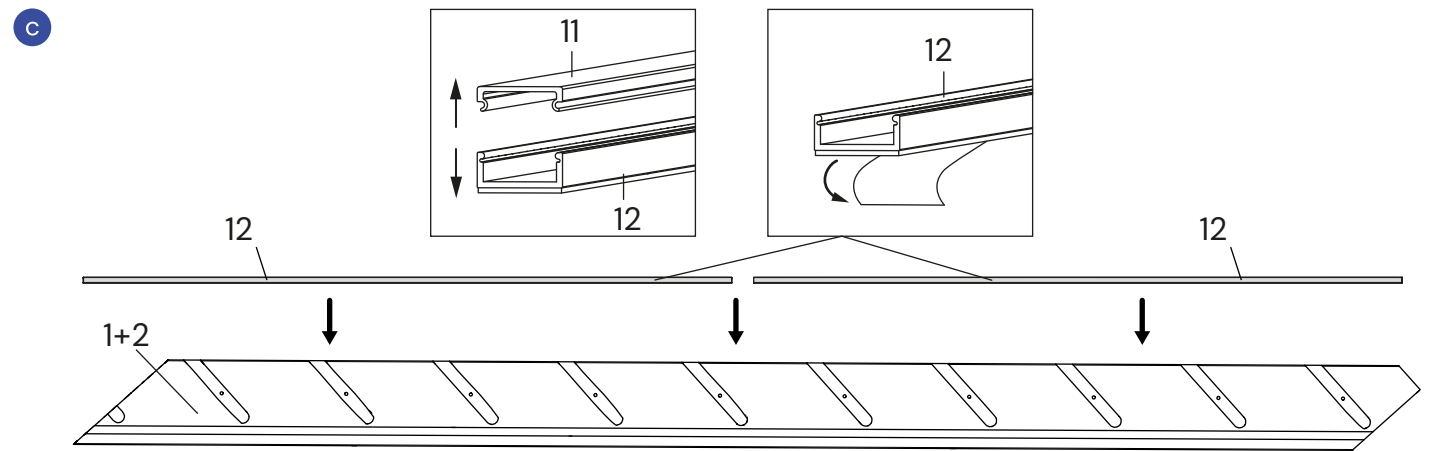
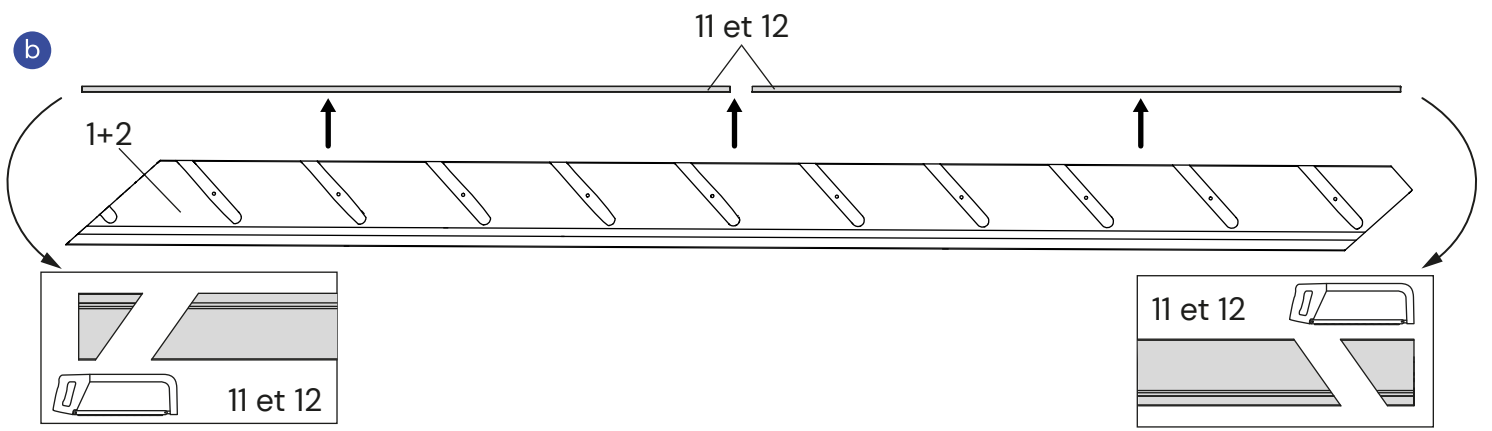

4

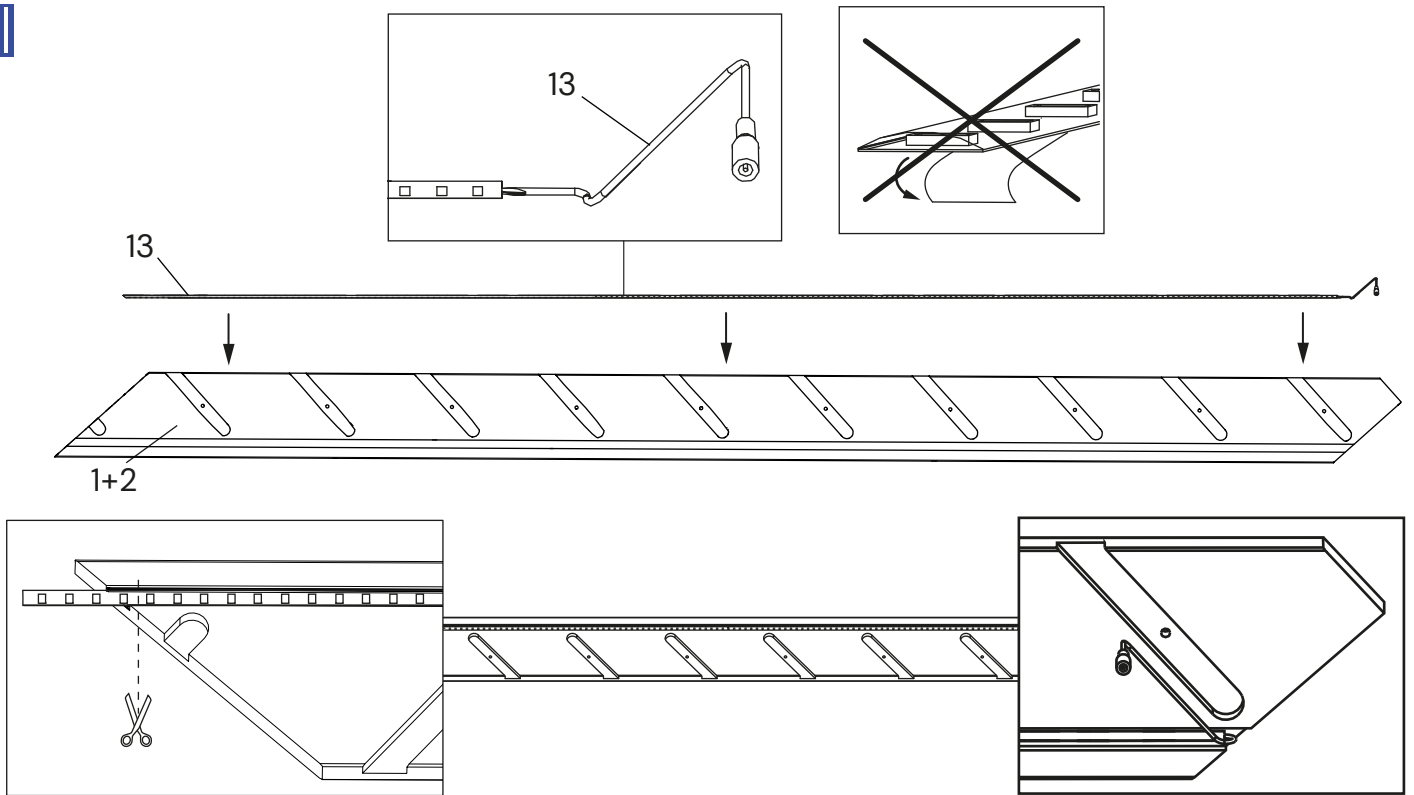

Découpe du ruban led

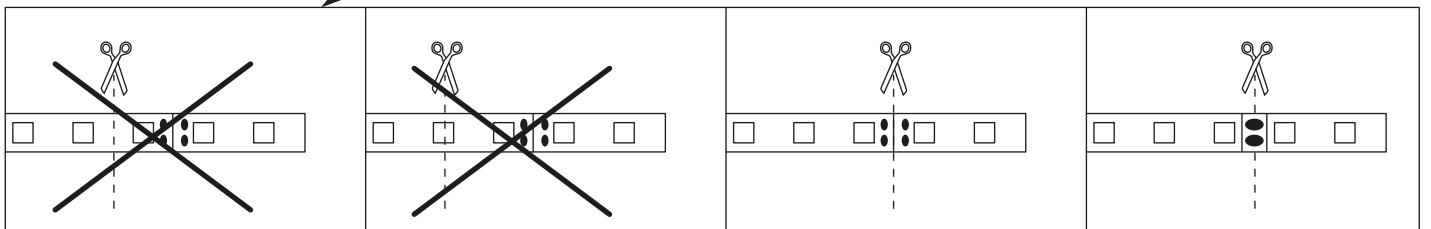

5

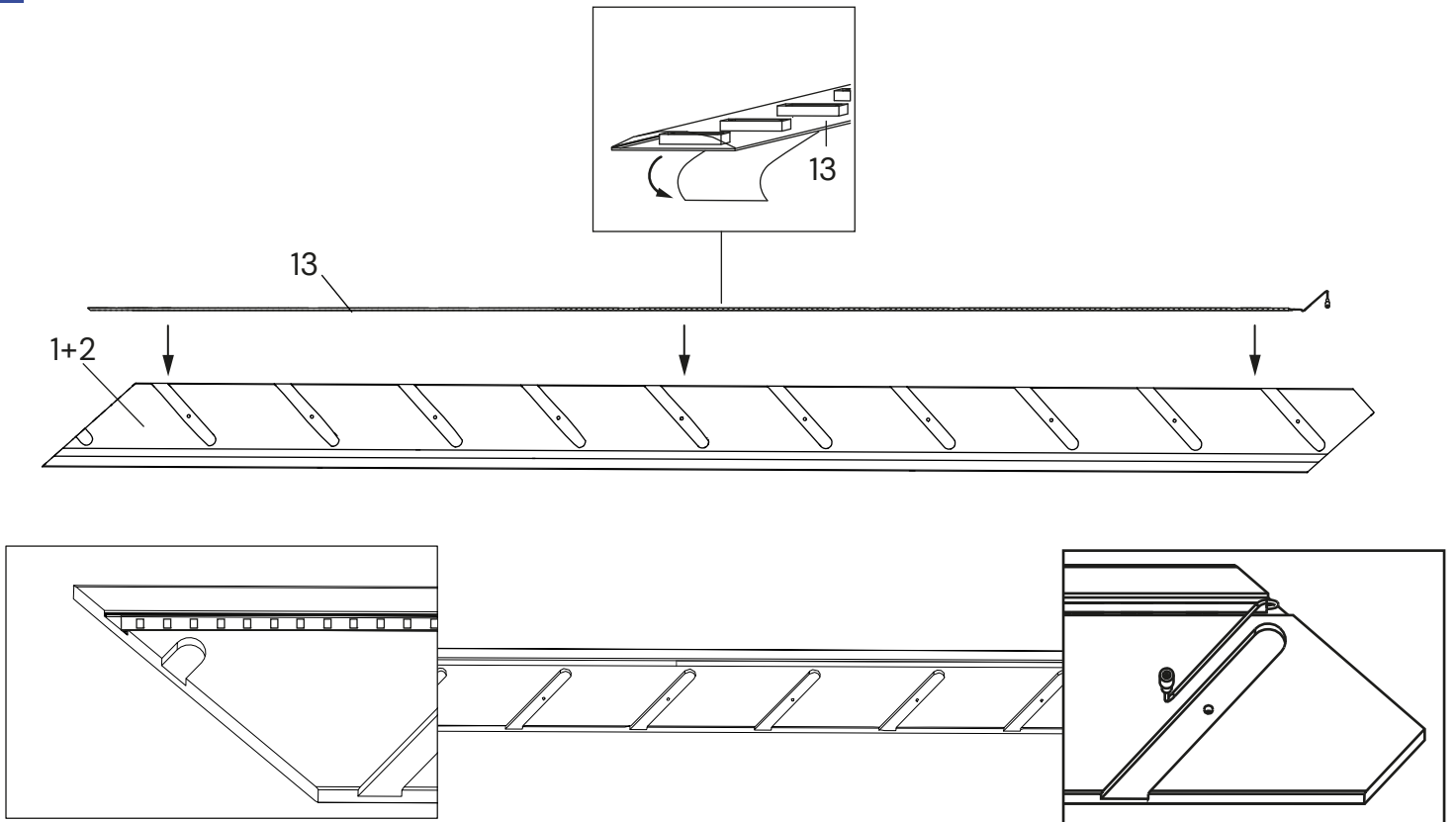

6

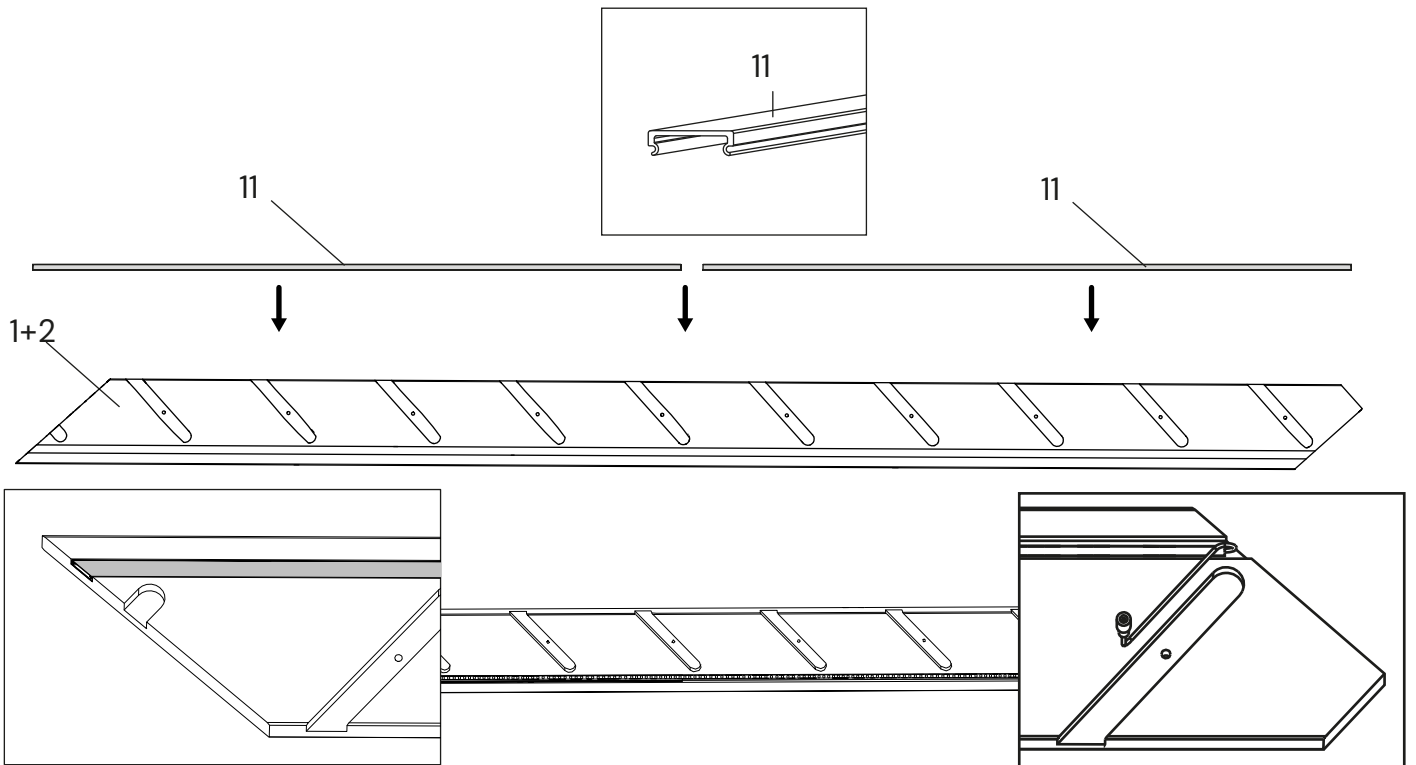

7

a

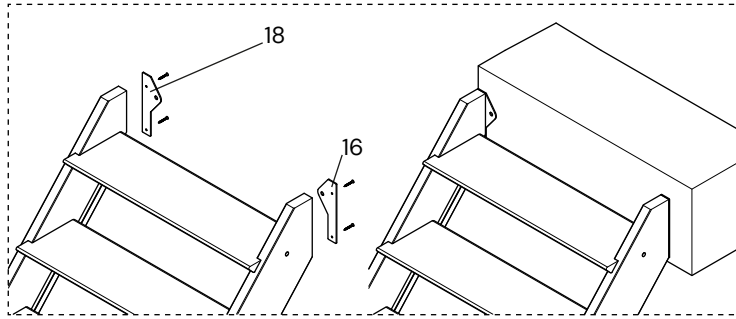

b

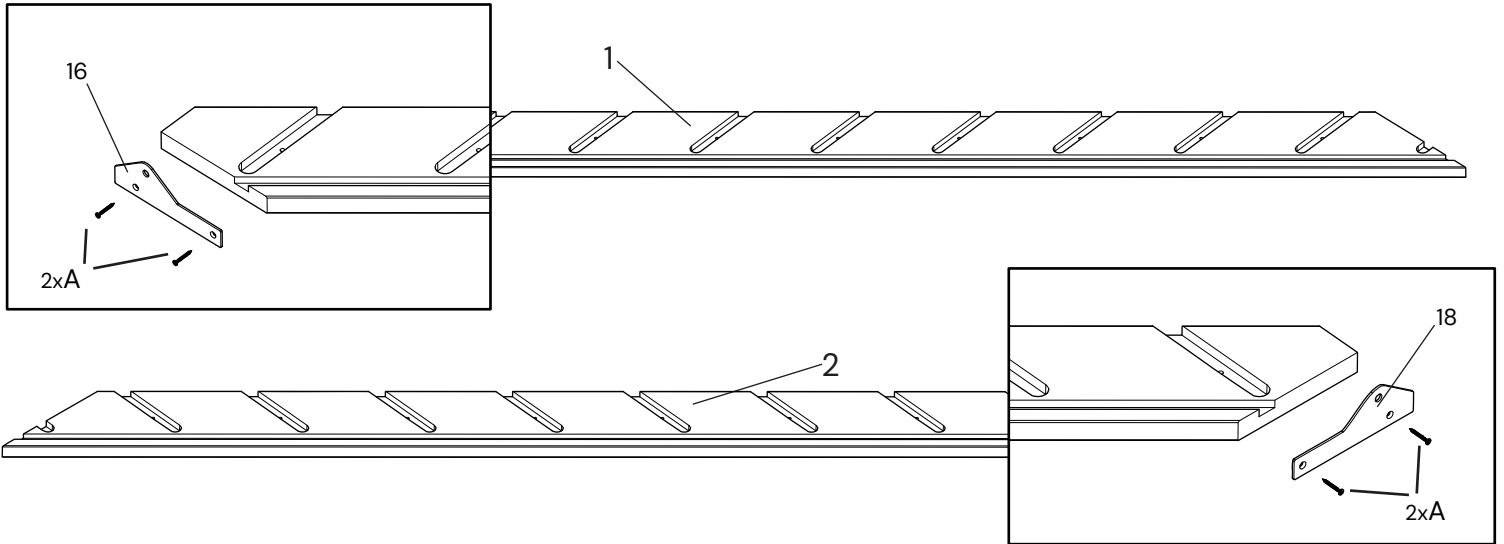
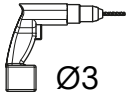

8

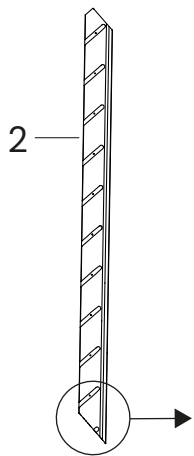

a

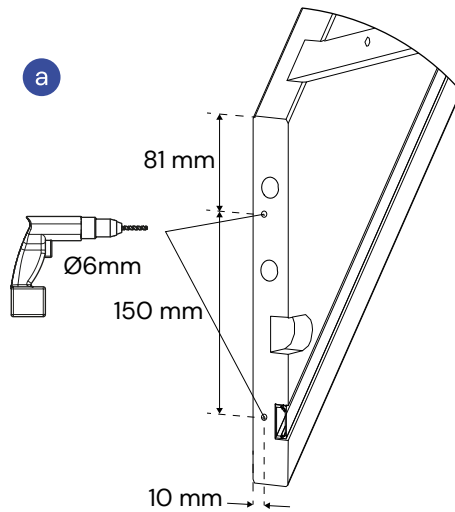

b

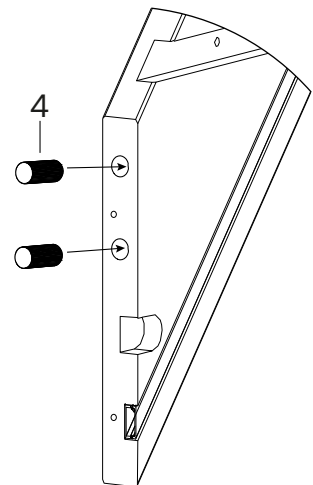

c

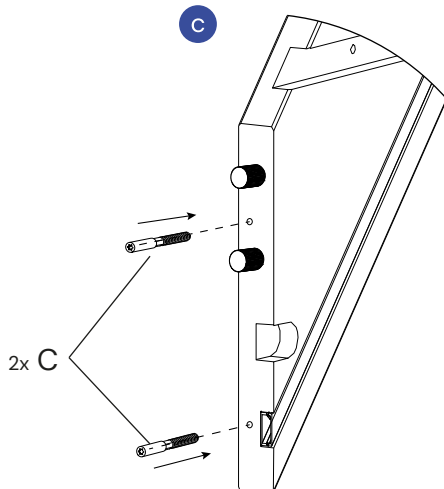

d

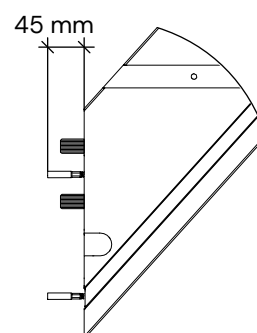

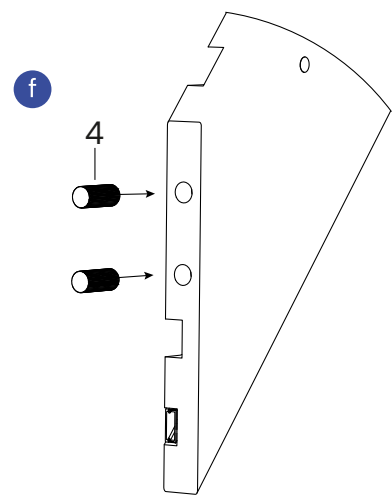
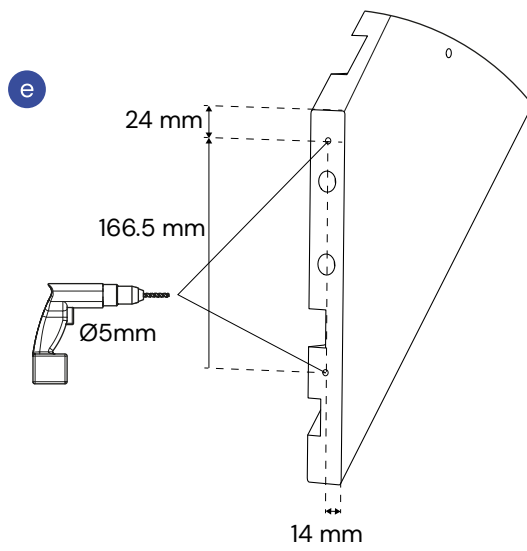
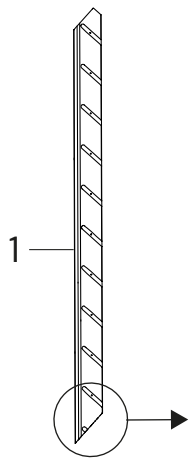

9 |

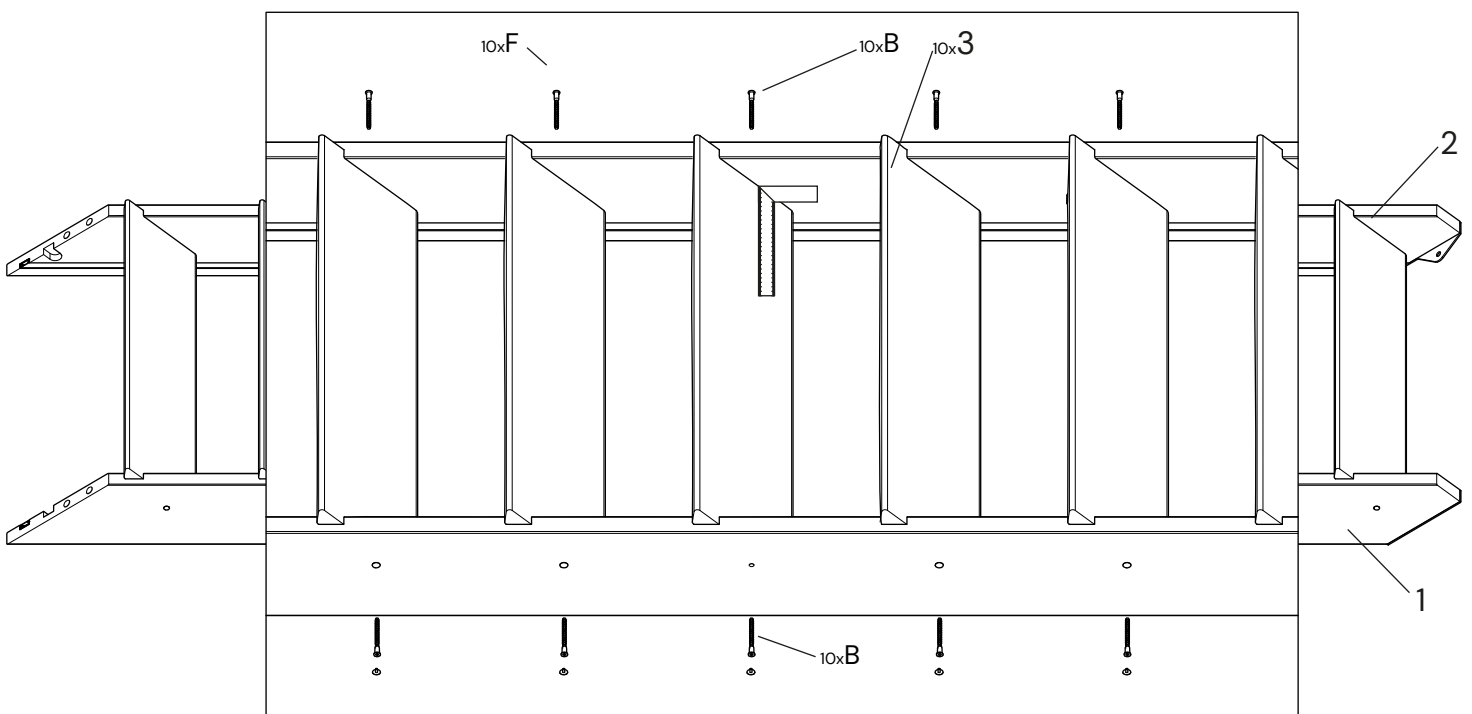

10

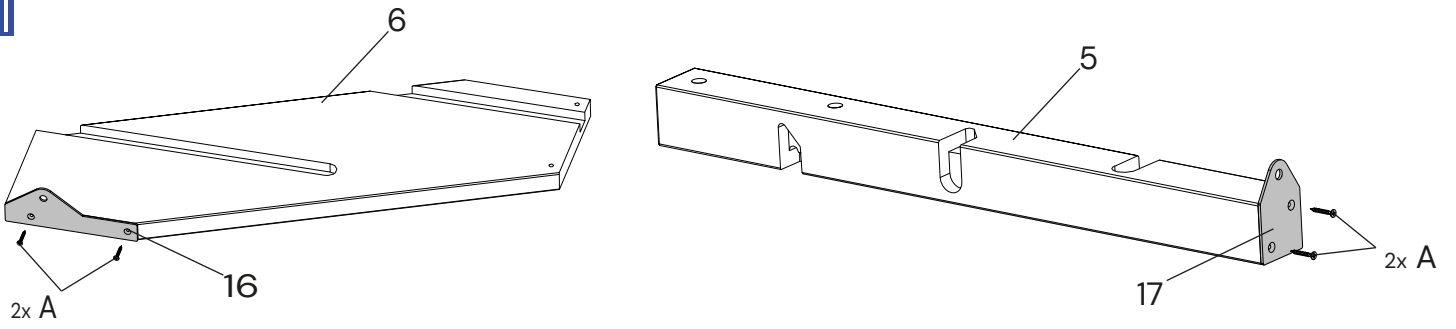

11

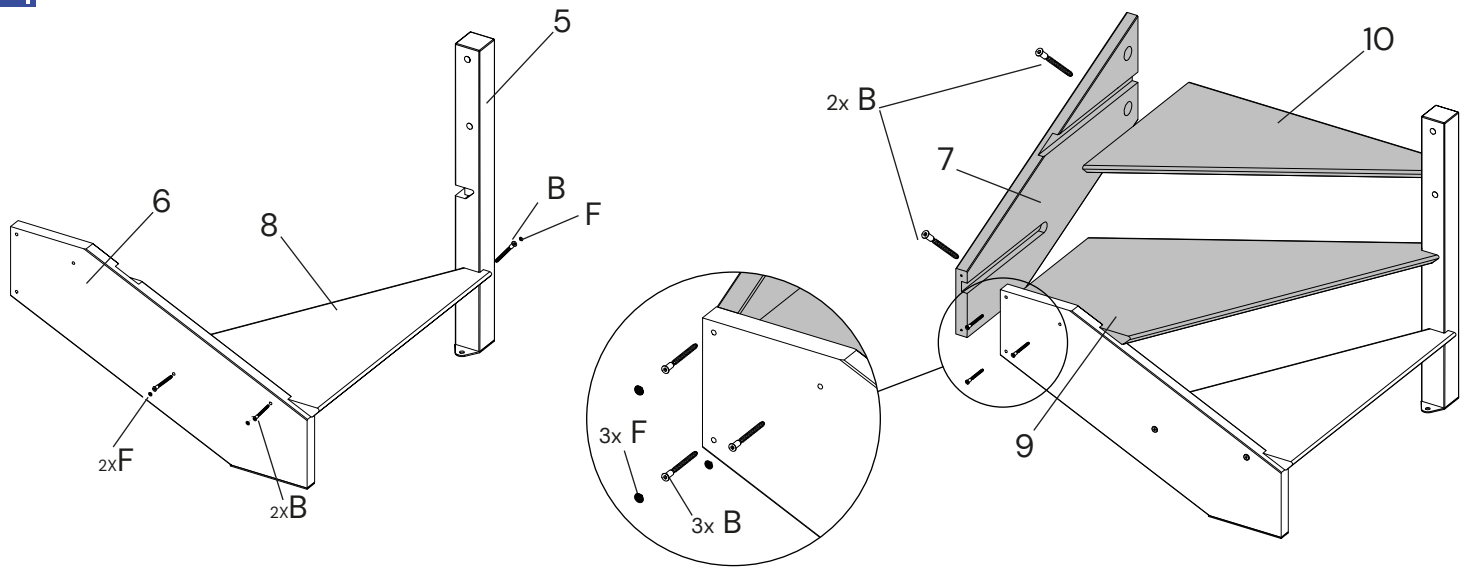

12

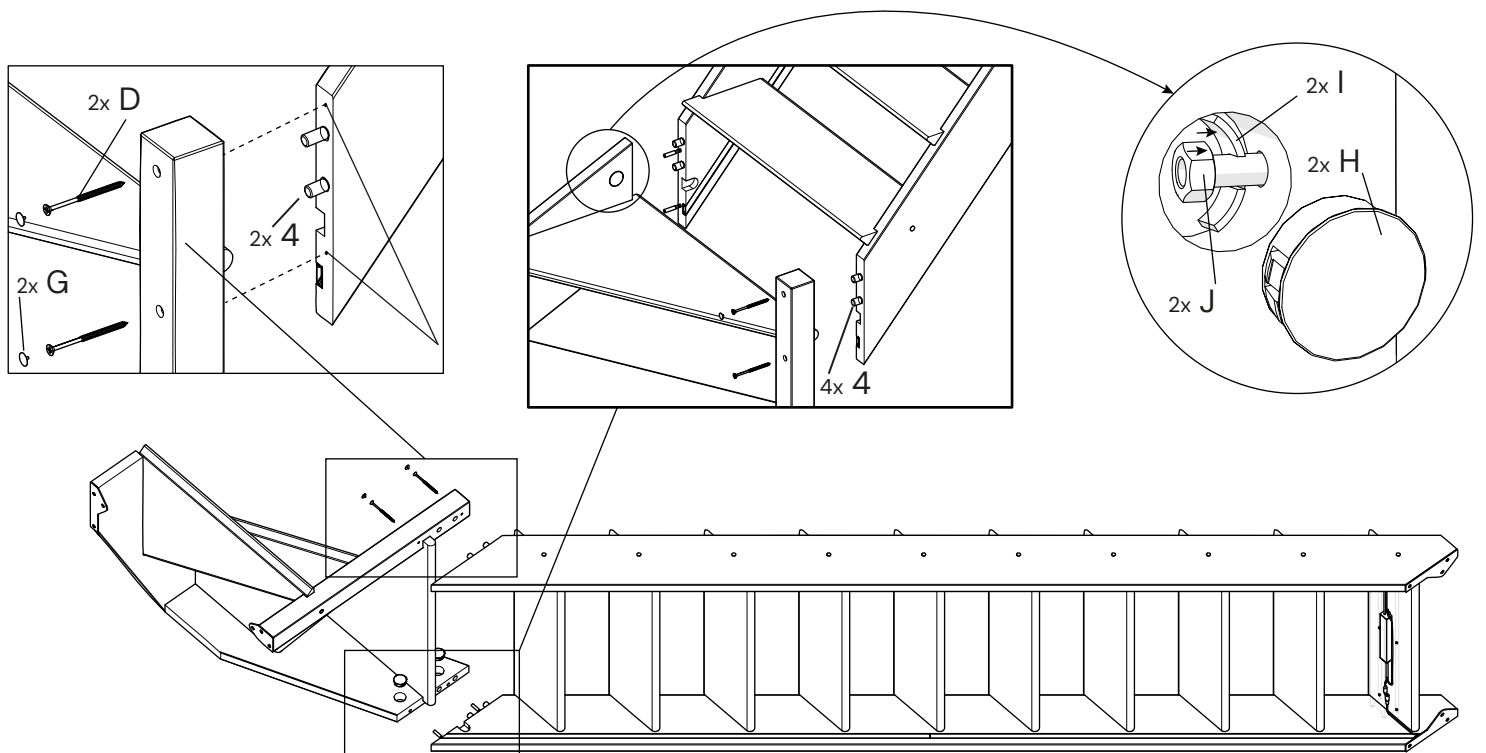

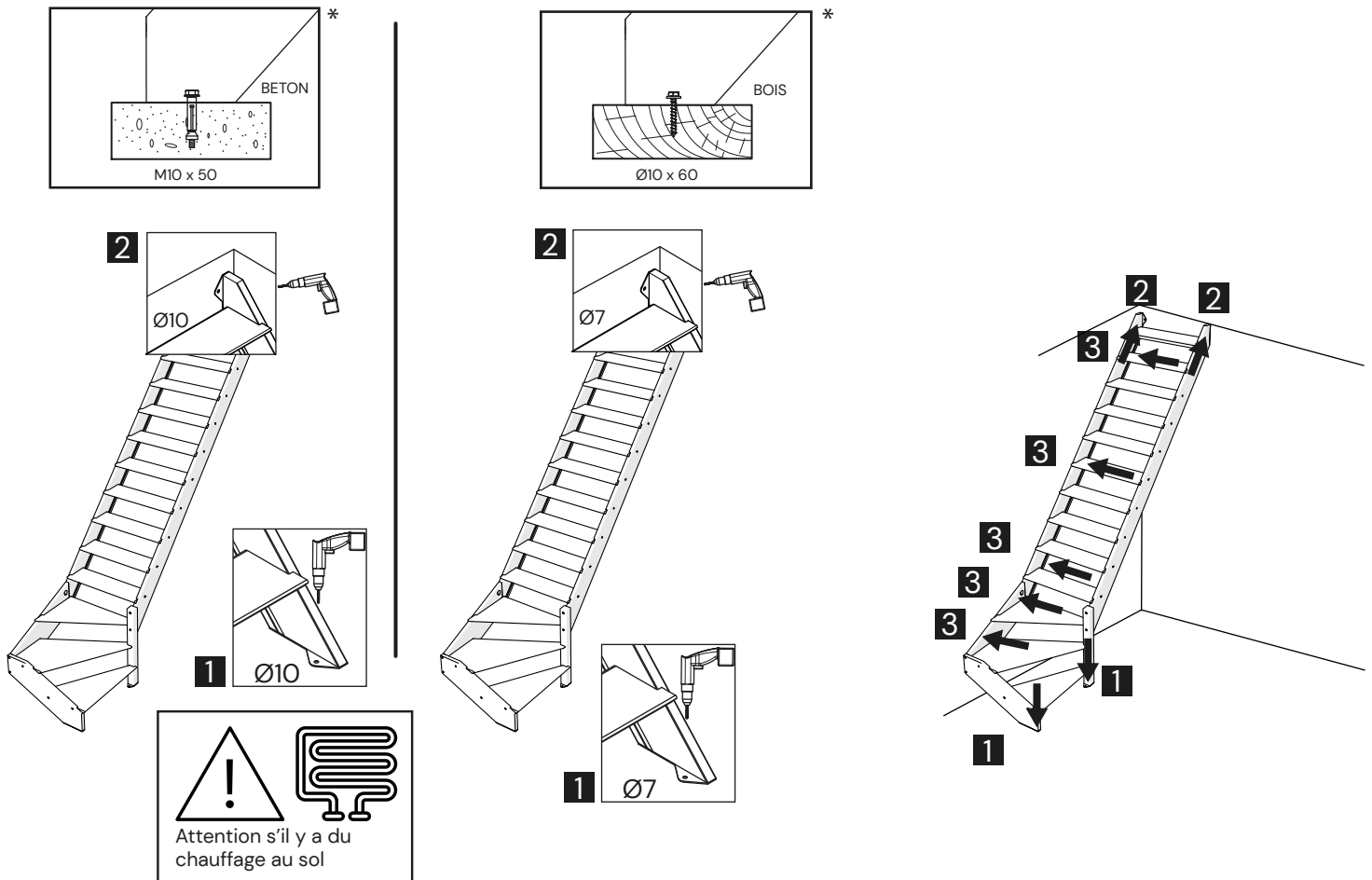

- * Ancrages non inclus.
 Anchors not included.
 Verankerungen nicht enthalten.
 Anclajes no incluidos.
 Ancoragens não incluídas.
 Ancoraggi non inclusi.
 Verankeringen niet inbegrepen.

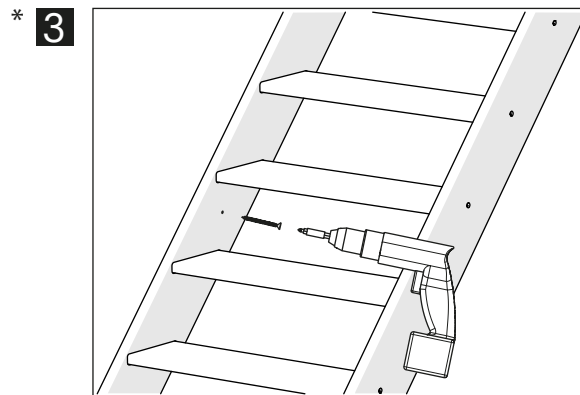

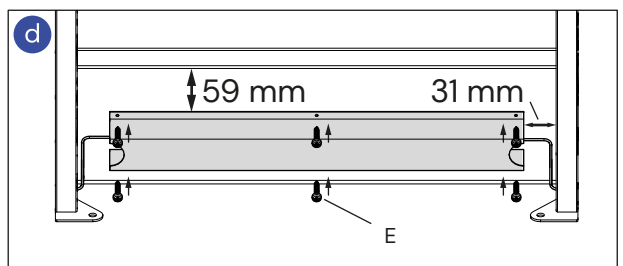
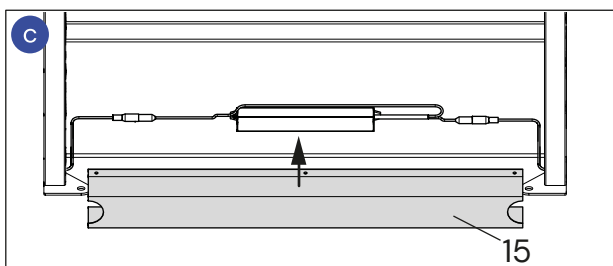
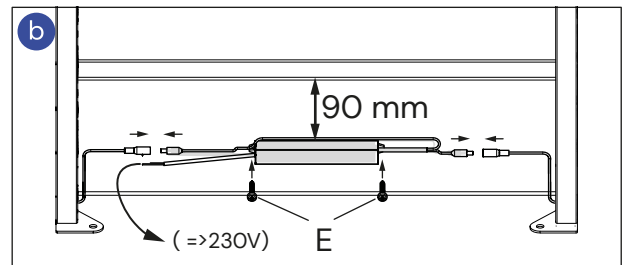
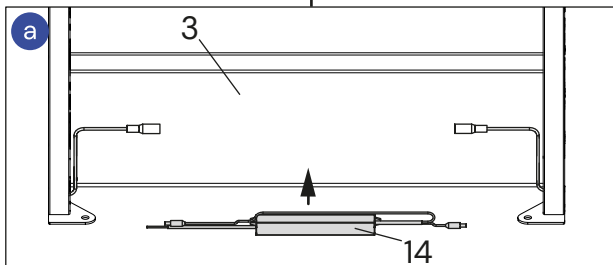
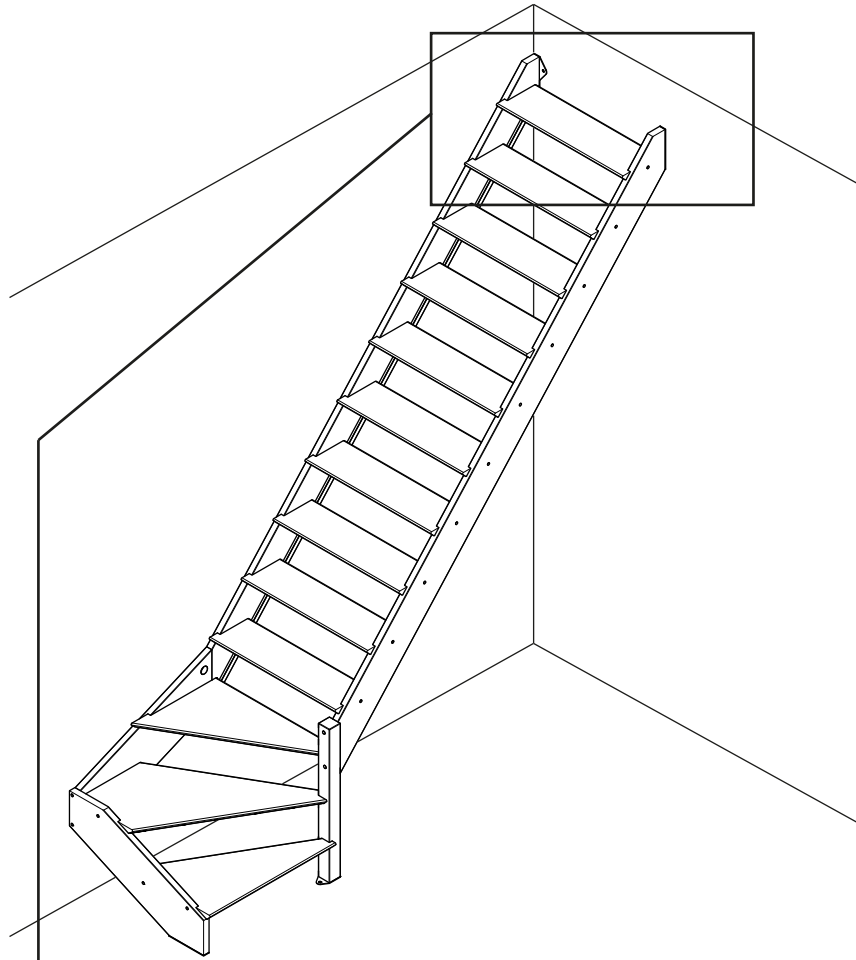

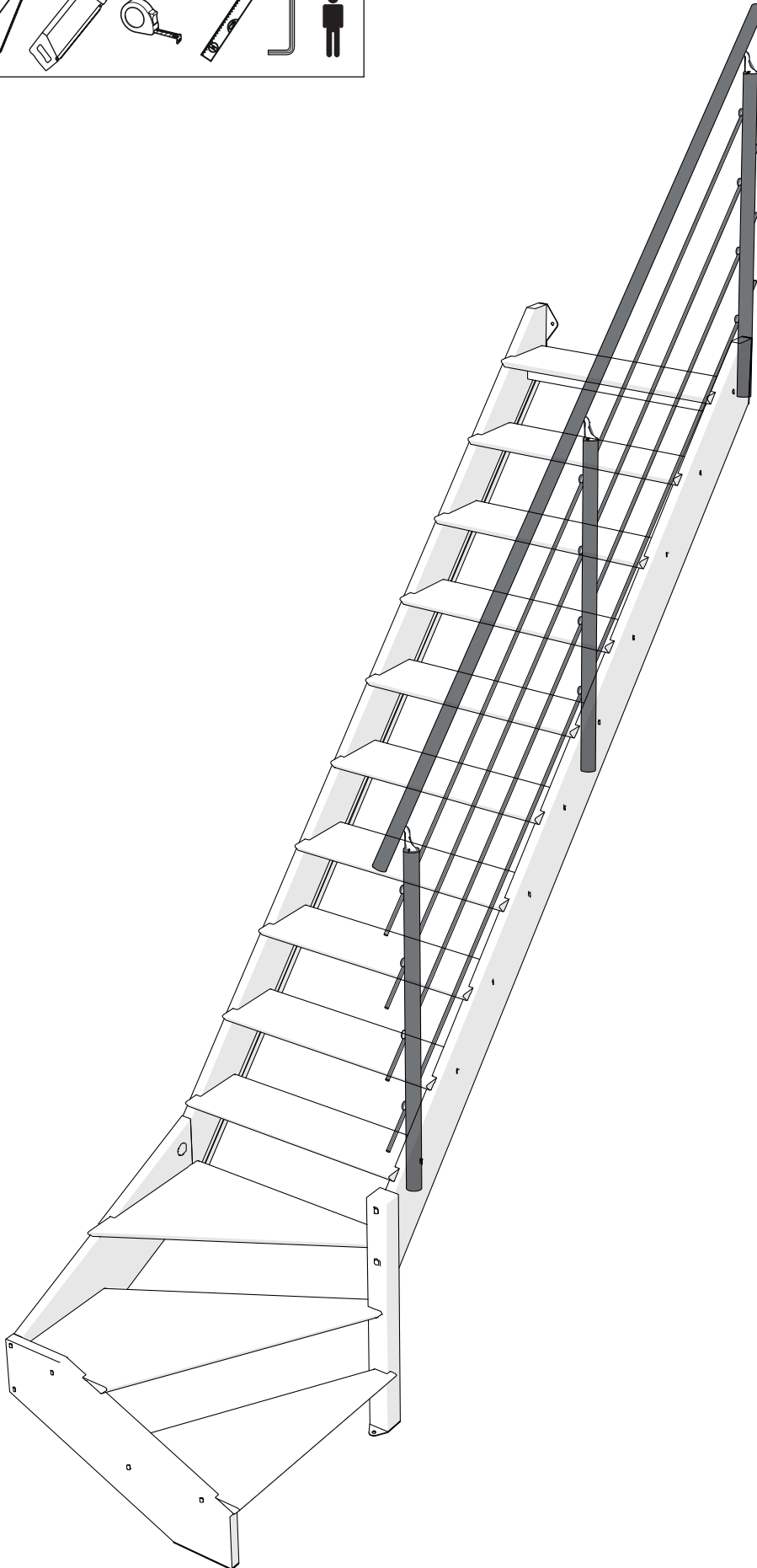
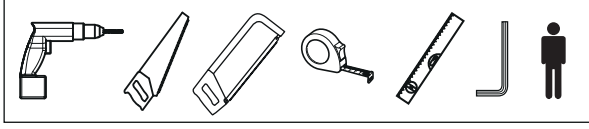

Les garde-corps fabriqués et vendus par la société BURGER&CIE sont conçus selon les normes NF P01-012.

AVANT MONTAGE

Vérifier le bon état et la présence de l'ensemble des pièces avant le montage. Ne pas modifier le produit.

Utiliser les cartons d'emballage pour protéger votre zone de travail. Respecter les règles de sécurité et le port des équipements de protection individuels (EPI), le principal risque encouru étant la chute. Eloigner les enfants lors du montage. Le montage d'un garde-corps n'est pas un acte anodin. Il doit être réalisé en respectant la notice de pose dans un environnement et avec des outils adéquats.

ENTRETIEN

Nettoyage du produit avec un chiffon doux et à l'eau claire additionnée d'un détergent doux (pH compris entre 5 et 8) suivi d'un rinçage soigné à l'eau claire puis un essuyage avec un chiffon doux, non abrasif et absorbant. Un nettoyage annuel minimum est nécessaire. Le support de nettoyage ne doit pas être agressif, ne doit pas abraser, rayer, décolorer ou colorer la couche de peinture. Les supports conseillés sont une éponge douce, un chiffon doux en matière non-abrasive (ouate, coton, non-tissé, non-pelucheux), de couleur blanche exclusivement. Les supports tels que éponges abrasives, paille de fer et chiffons de couleur sont exclus. À réception du produit, il convient de l'installer dans un environnement tempéré, à l'abri de l'humidité.

CONDITIONS DE GARANTIES

Notice et référence de traçabilité à conserver, nécessaire en cas de SAV.

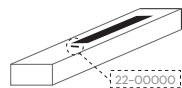

Référence à communiquer
pour toute demande.

La durée et les conditions de garanties peuvent être consultées sur : <https://b2b.kordodesign.com/garanties>.

The banisters manufactured and sold by burger & cia are designed according to standards NF P01-012.

BEFORE ASSEMBLY

Check the condition and presence of all parts before assembly. Do not modify the product.

Use the packaging cartons to protect your work area. Follow safety rules and wear personal protective equipment (ppe),

the main risk is falling. Keep children away during assembly. Assembling a banister is not a trivial task.

It must be carried out following the instruction in a suitable environment and with appropriate tools.

MAINTENANCE

Clean the product with a soft cloth and clear water mixed with mild detergent (ph. between 5 and 8) , followed by careful rinsing

With clear water and wiping with a soft, non-abrasive , absorbent cloth. At least one annual cleaning is necessary.

The cleaning material must not be aggressive; it should not abrade, scratch, discolor, or color the paint layer. Recommended materials are a soft sponge, a soft cloth made of non-abrasive material (wadding, cotton, non-woven, lint-free), exclusively in white color.

Abrasive sponges, steel wool, and colored cloths are excluded. Upon receipt of the product, it should be installed in a temperate environment, away from humidity.

WARRANTY CONDITIONS

Keep the instructions and traceability reference, necessary for after-sales service.

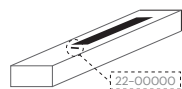

Reference must be provided for any
request.

The duration and warranty conditions can be consulted at : <https://b2b.kordodesign.com/garanties>.

Die von der Firma BURGER&CIE hergestellten und verkauften Geländer sind nach den französischen Normen NF P01-012.

VOR DER MONTAGE

Prüfen Sie den guten Zustand und das Vorhandensein aller der Teile vor der Montage. Das Produkt nicht verändern.

Verwenden Sie Verpackungskartons, um Ihren Arbeitsbereich zu schützen. Beachten Sie die Sicherheitsvorschriften und tragen Sie persönliche Schutzausrüstung (PSA), da das größte Risiko ein Sturz ist. Halten Sie Kinder während des Einbaus fern. Die Montage eines Geländers ist kein harmloser Akt. Es muss unter Beachtung der Montageanleitung in einer geeigneten

Umgebung und mit geeigneten Werkzeugen durchgeführt werden

VOR DER MONTAGE

Produktsreinigung mit einem weichen Lappen und mit klarem Wasser mit einem schonenden Waschmittel (pH zwischen 5 und 8) , dann eine Spülung mit klarem Wasser und ein Abtrocknen mit einem weichen, nicht schleifenden und absorbierenden Lappen. Eine jährliche Mindestreinigung ist erforderlich. Das Reinigungsmaterial darf nicht aggressiv sein und die Farbschicht nicht abschleifen, zerkratzen, verfärben oder ausbleichen. Ein weicher Schwamm, ein weicher Lappen aus nicht schleifenden Material (Watte, Baumwolle, Vlies, nicht fusselfig) und exklusiv in weißer Farbe sind empfohlene Materialien. Reinigungsmaterial wie Schleifschwämme, Stahlschwämme und farbige Tücher sind ausgeschlossen. Beim Empfang des Produkts, es ist empfohlen, es in einer temperierter Stelle hinzulegen, wenn möglich vom Feuchtigkeit geschützt.

GARANTIEBEDINGUNGEN

Anleitung und Rückverfolgbarkeitsnummer zu behalten, und im Falle einer Kundenreklamation benötigt werden.

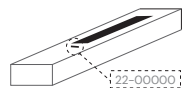

Die Artikelnummer ist bei
jeder Anfrage anzugeben.

Die Dauer- und die Garantiebedingungen können unter : <https://b2b.kordodesign.com/garanties> eingesehen werden.

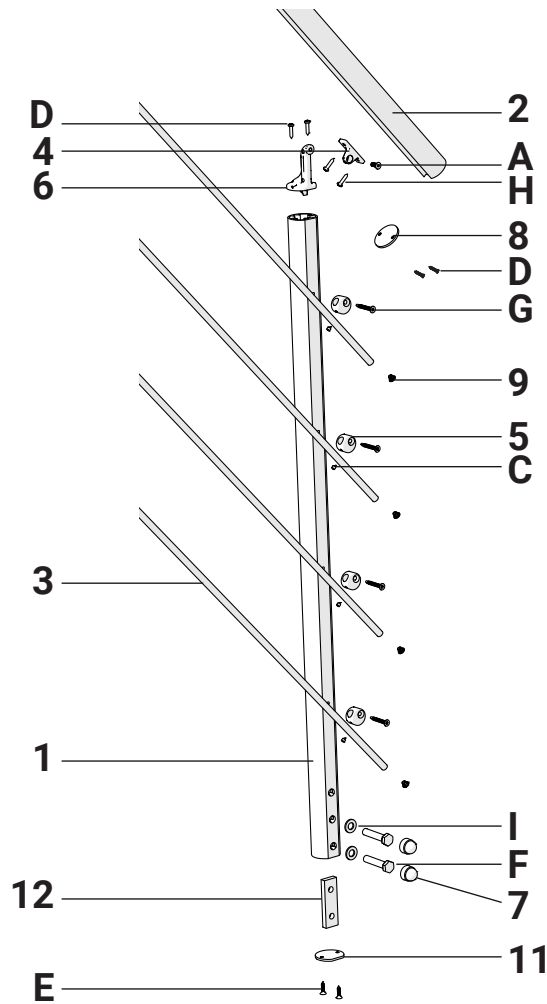
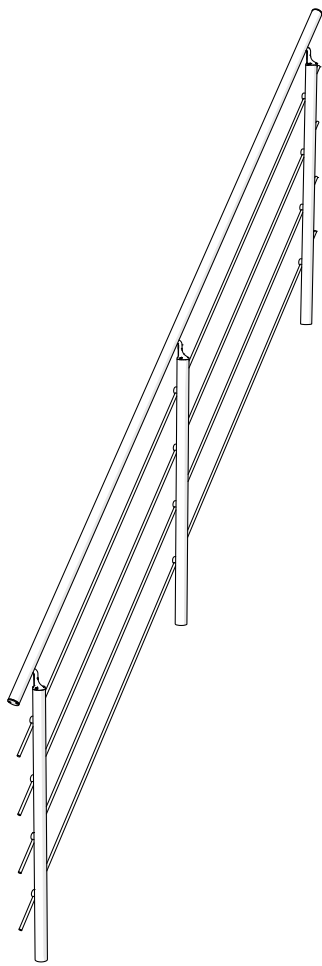

1	30023		Ø43x976mm	x3
2	23456		Ø40x3000mm	x1
3	72758		Ø10x3000mm	x4

4	70135		x3
5	70133		x12
6	70134		x3
7	72318		x6
8	70161		x2
9	70071		x10
10	70030		x5
11	70396		x3
12	70467		x3



A	72285		M5x14mm	x3
B	72064		Ø3.5x20mm	x3
C	72067		M5x6mm	x15
D	72341		Ø4.2x19mm	x12
E	72549		Ø4.2x19mm	x6
F	72438		M10x50mm	x6
G	1665		Ø4.8x38mm	x15

H	72063		Ø3x30mm	x2
I	72055		Ø M10mm	x6
J	72759		4x100x187 mm	x1



1

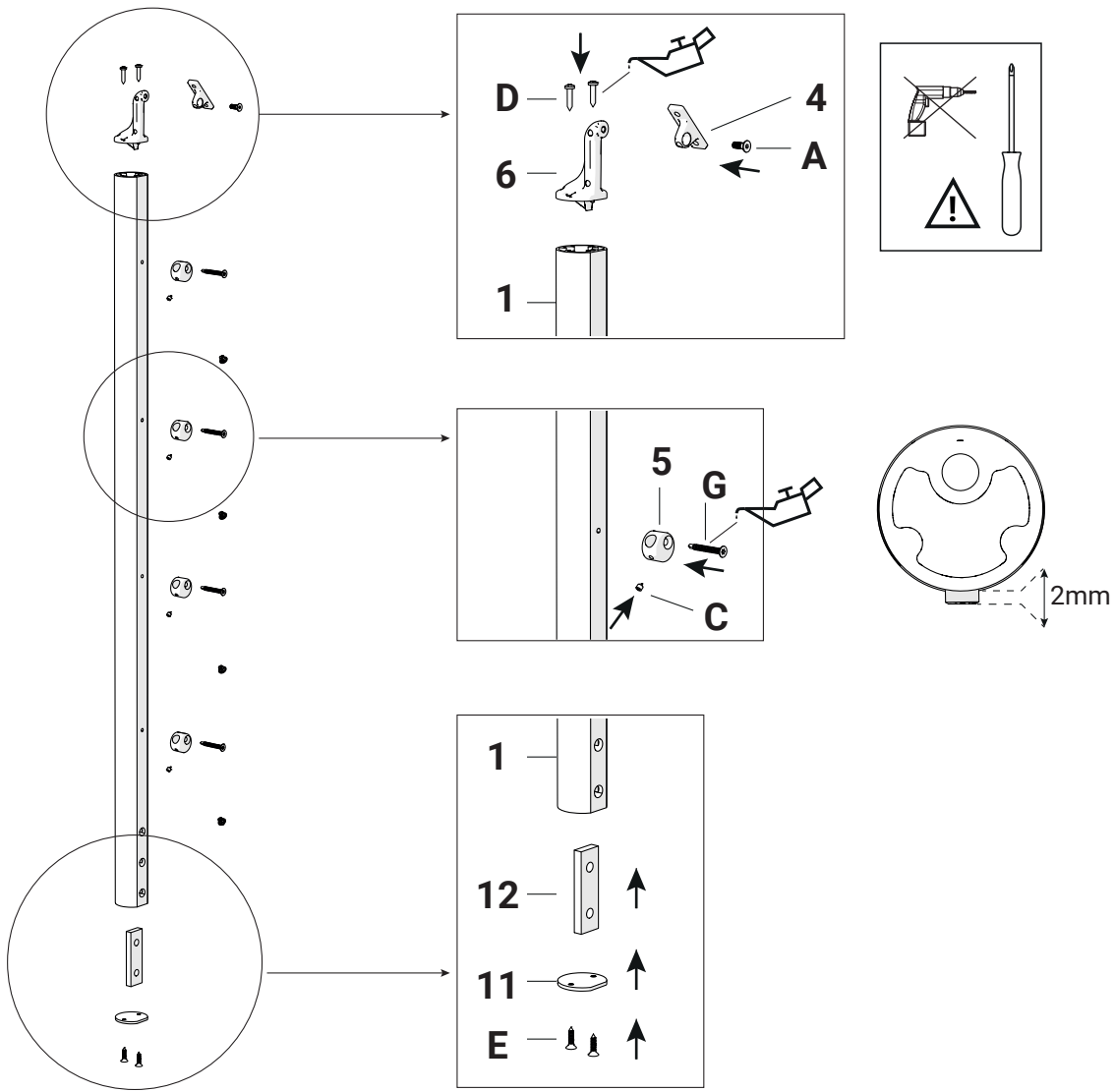

2

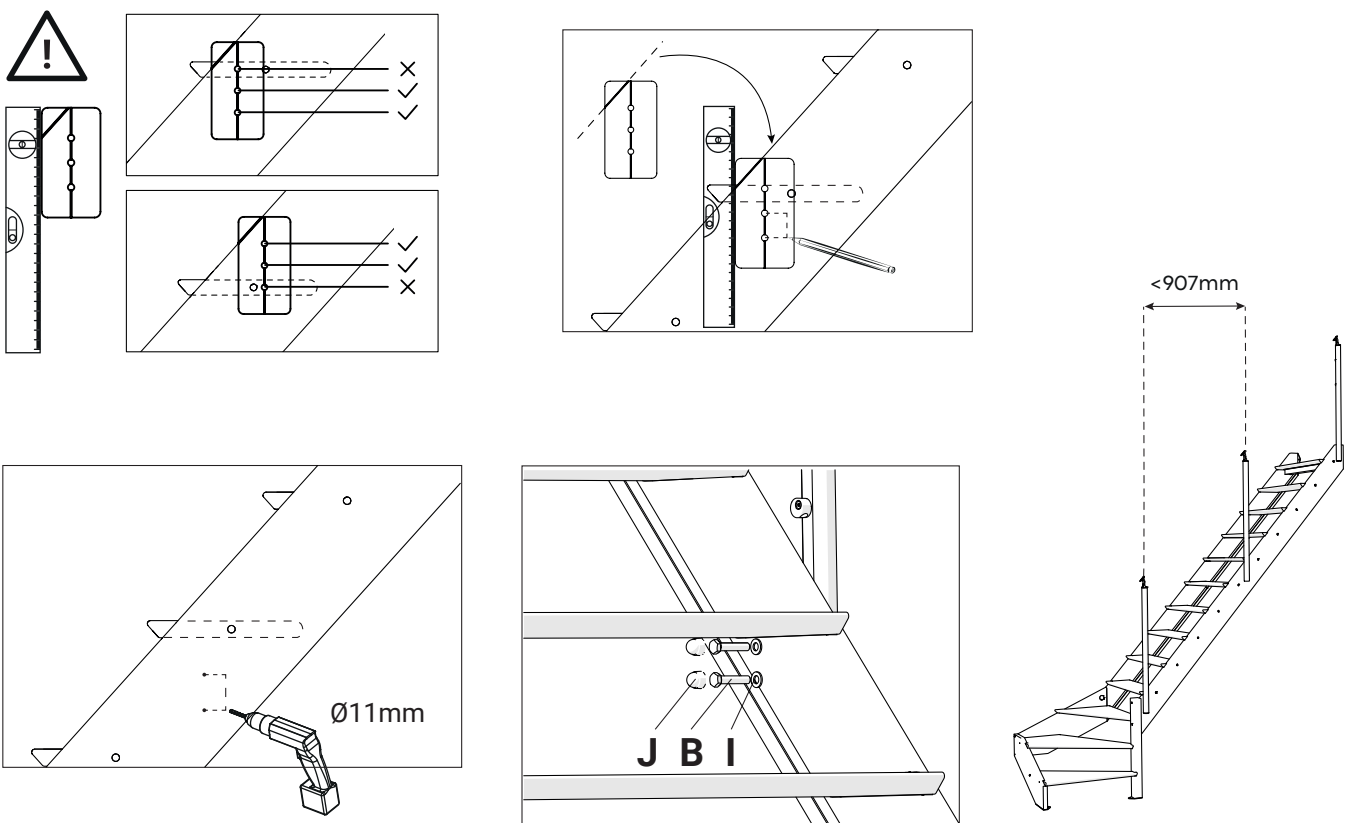

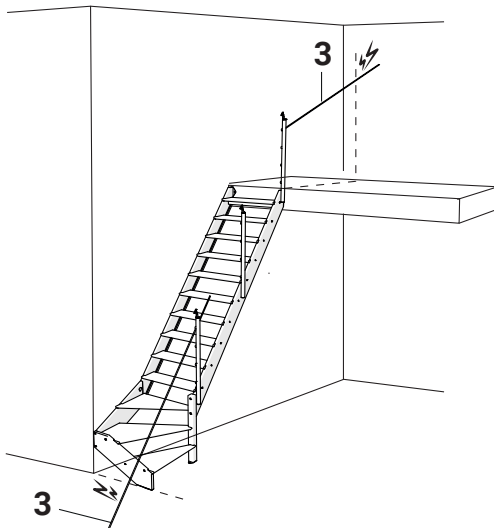
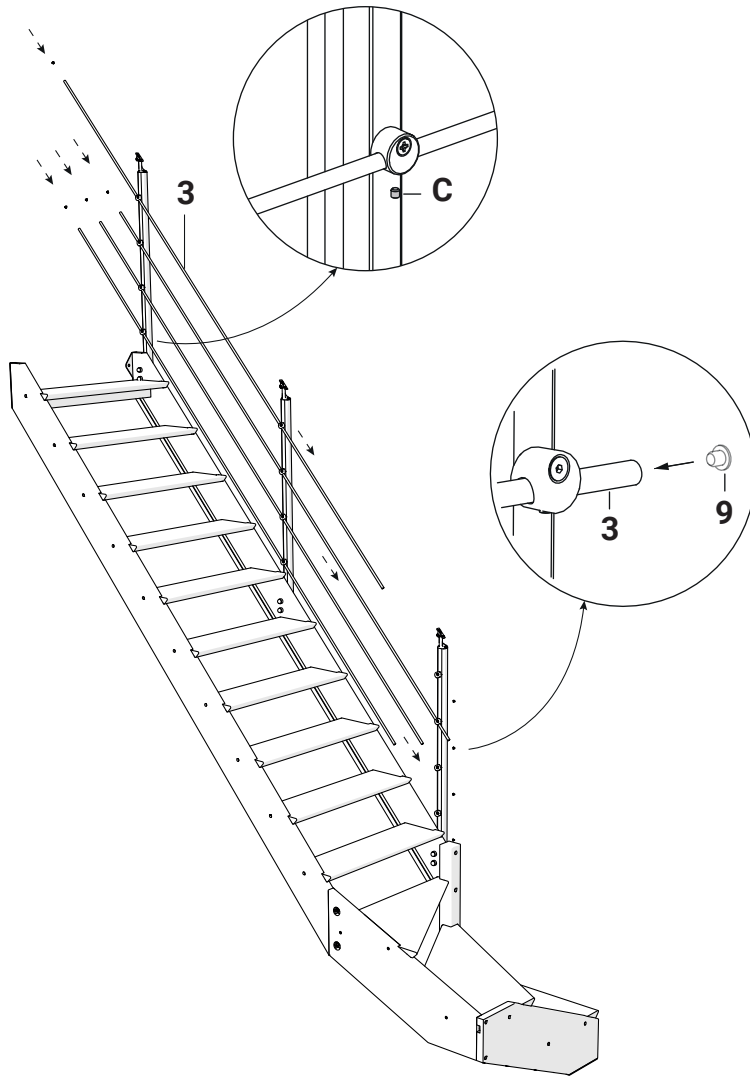

a

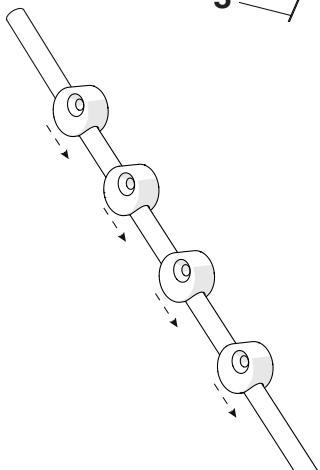

b

