

# FAR TOOLS®

- FR** *Visseuse à plaque de plâtre (Notice originale)*
- EN** *Plasterboard screw inserter (Original manual translation)*
- DE** *Gipsplattenschrauber (Übersetzung aus dem Original-Anleitung)*
- ES** *Atornillador para placas de yeso (Traducción del manual de instrucciones originale)*
- IT** *Avvitatrice per cartongesso (Traduzione dell'avvertenza originale)*
- PT** *Aparafusadora para gesso (Tradução do livro de instruções original)*
- NL** *Schroevendraaier voor gipsplaat (Vertaling van de originele instructies)*
- EL** *Μηχανή βιδώματος για πλάκες γύψου (Μετάφραση από τις πρωτότυπες οδηγίες)*
- PL** *Wkretarka do płyt kartonowo-gipsowych (Tłumaczenie z oryginalnej instrukcji)*
- FI** *Laastiin ruuvaava porakone (Käännös alkuperäisestä ohjeet)*
- SV** *Skruvdragare för gipsskivor (Översättning från originalinstruktioner)*
- BU** *Skruemaskine til gipsplader (Перевод на оригиналната инструкция)*
- DA** *Gipsplade skruetrækker (Oversættelse fra oprindelige brugsanvisning)*
- RO** *Mașină de înșurubat pentru gips-carton (Traducere din instrucțiunile originale)*
- RU** *Шуруповерт для гипскартона (Перевод с оригинальной инструкции)*
- TU** *Elektri 'kli` vi`dalama maki`nasi (Orişinal talimatlar çeviri)*
- CS** *Uzavíračka pro sádru (Překlad z originálního návodu)*
- SK** *Uzatvárač na sadru (Preklad z originálneho návodu)*
- HE** *תוירוקמ תוארומה סוגרת) סימלה הגרבמ*
- AR** *(قيلصلأا تاميلعل علأا نم قمجرتلأا) يئأابرهك لغم*
- HU** *Gipszkarton csavarozó (Fordítás az eredeti utasítások)*
- SL** *Vijačnik za mavčne plošče (Prevod iz izvirnih navodil)*
- ET** *Kruvikeeraja kipsmaterjalidele (Tõlge originaal juhiseid)*
- LV** *Apmetuma plākšņu skrūvgriezis (Tulkojumā no instrukcijas oriģinālvalodā)*
- LT** *Gipsinis tvirtinimo aparatas (Vertimas iš originalių instrukcijas)*
- HR** *Odvijač za gips ploče (Prijevod prema originalne upute)*



**PM 6C**  
Professional Machine



© FAR GROUP EUROPE

115009-3-F-2021103

**fartools.com**



Points de collecte sur [www.quefairede mesdechets.fr](http://www.quefairede mesdechets.fr)  
Privilégiez la réparation ou le don de votre appareil !

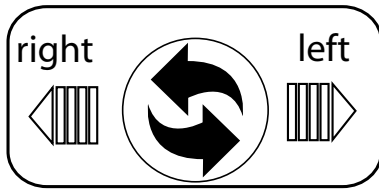

on  
off

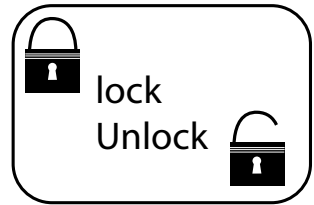

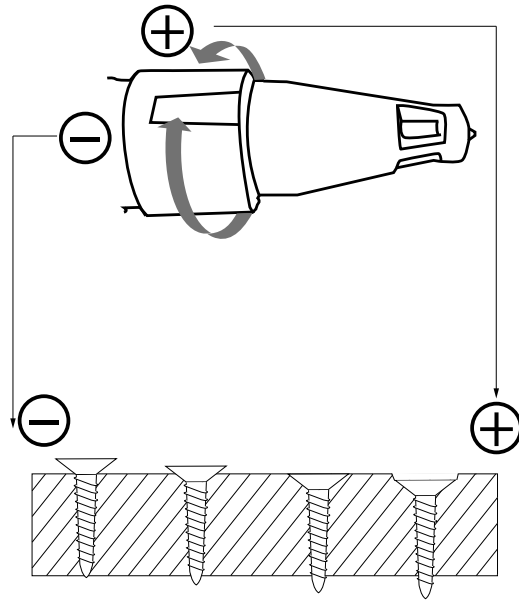



	<p>Tension et fréquence assignée: Nominal frequency and power: Nennspannung und Nennfrequenz : Tensión y frecuencia fijada: Tensione e frequenza assegnata: Tensão e frequência fixa: Aangewezen spanning en frequentie: ΟΝΟΜΑΣΤΙΚΗ ΤΑΣΗ ΚΑΙ ΣΥΧΝΟΤΗΤΑ: Napięcie i częstotliwość przydzielona: Jännite ja määrittäy taajuus: Angiven spänning och frekvens: Anført spænding og frekvens: Tensiune și frecvență de lucru:</p>	<p>Заданное напряжение и частота: Tahsis gerilimi ve frekans: Stanovené napětí a frekvence: Stanovené napätie a frekvencia: Merkespenning og merkefrekvens: الفالطية والذبذبة المبرمجة. Névleges feszültség és frekvencia: Napetost in določena frekvenca: Консумирано напрежение и честота : Määratud pinge ja sagedus Nustatyta įtampa ir dažnis Noteiktais spriegums un frekvence. Napon i nazivna frekvencija:</p>	230 V ~ 50 Hz
--	--	--	---------------

	<p>Puissance assignée: Nominal power: Nennleistung: Potencia fijada: Potenza assegnata: Potência assinada: Onbelast toerental: ΟΝΟΜΑΣΤΙΚΗ ΙΣΧΥΣ: Prędkość na biegu jałowym: Teho: Angiven effekt: Anført styrke: Putere de lucru:</p>	<p>Заданная мощность: Tahsis edilen güç: Stanovený výkon: Predpísaný výkon: Merkeeffekt: القدرة المبرمجة. Névleges teljesítmény : Določena jakost: Консумирана мощность: Määratud võimsus. Nustatyta galia Noteiktā jauda Nazivna snaga:</p>	520 W
--	---	--	-------

	<p>Vitesse à vide: No-load speed: Leerlaufdrehzahl: Velocidad vacía: Velocità a vuoto: Velocidade no vácuo: Leerlaufdrehzahl: ΤΑΧΥΤΗΤΑ ΑΔΡΑΝΕΙΑΣ: Prędkość bez obciążenia: Tyhjäkäyntinopeus Tomgångshastighet: Hastighed i ubelastet tilstand: Viteza în gol:</p>	<p>Скорость вращения на холостом ходу: Boşalma hızı: Rychlost naprázdno: Rýchlosť pri chode naprázdno: Tomgangshastighet: السرعة على الفارغ. Üres sebesség: Prosti tek: Скорост на празни обороти: Kiirus tühikäigul Tuščio prietaiso greitis Tukšgaitas ātrums Brzina praznog hoda:</p>	0-4200 min <sup>-1</sup>
--	--	--	--------------------------

	<p>Poids : Weight : Gewicht : Peso : Peso : Gewicht : ΒΑΡΟΣ : Masa : Paino : Vikt : Vægt : Greutate :</p>	<p>Вес : Ağırlık : Hmotnosť : Hmotnosť : Vekt: الوزن. Súly : Teža : Тегло : Raskus Svoris Svars Težina</p>	1.60 kg
--	---	--	---------





 <b>L<sub>pA</sub></b>	Niveau de pression acoustique :	Уровень акустического давления. :	85,7 dB (A)
	Acoustic pressure level :	Akustik basınç seviyesi :	
	Schalldruckpegel :	Hladina akustického tlaku :	
	Nivel de presión acústica :	Hladina akustického tlaku :	
	Livello di pressione acustica :	Lydryknivá:	
	Nível de pressão acústica :	مستوى الضغط المرصومي.	
	Niveau akoestische druk :	A hangnyomás szintje :	
	ΣΤΑΘΜΗ ΗΧΗΤΙΚΗΣ ΠΙΕΣΗΣ:	Nivo akustičnega pritiska:	
	Poziom mocy akustycznej :	Равнище на акустично налягане :	
	Käytä kuulosuojaimia:	Helirõhu nivoo	
Ljudtrycksnivå :	Akustinio spaudimo lygis		
Lydtryk :	Akustiskā spiediena līmenis		
Nivel presiune acustică :	Razina zvučnog tlaka:		

 <b>L<sub>wA</sub></b>	Niveau de puissance acoustique :	уровень мощности звука :	96,7 dB (A)
	Acoustic power level :	Akustik basınç seviyesi :	
	Schalleistungspegel :	Hladina zvukového výkonu:	
	Nivel de potencia acústica :	Hladina zvukového výkonu:	
	Livello di potenza acustica:	Lydeffektivitvå:	
	Nível de potência acústica:	مستوى الضغط ج.ج.	
	Niveau akoestisch vermogen :	a hangnyomás szintje :	
	ΕΠΙΠΤΕΔΟ ΙΣΧΥΟΣ ΗΧΟΥ:	Nivo akustične jakosti :	
	Poziom mocy akustycznej :	Равнище на вибрации :	
	Käytä suojalaseja :	Helivõimsuse nivoo	
Ljudstyrkenivå :	Triukšmo lygis		
Lydstyrke :	Akustiskās jaudas līmenis		
Nivel putere acustică :	Razina zvučne snage:		

NIVEAU SONORE D'ÉMISSION :

A VIDE

Pression acoustique LpA poste opérateur  
Incertitude

85,7 dB  
3

Puissance acoustique LWA  
Incertitude

96,7 dB  
3

Valeurs déterminées suivant le code d'essai de l'annexe B de la norme EN 61029-1 avec emploi des normes de base ISO 11201 et ISO 3744.

Les niveaux de pression acoustique obtenus in situ dépendent:

- Des niveaux réels de la machine considérées, en prenant en compte les incertitudes déclarées;
- Du local et de l'installation de la machine. Préférez une pièce dont l'acoustique est plus feutrée. Evitez les pièces vides à grande résonance. Placez vous auprès d'une fenêtre le cas échéant.
- Des outils montés, des pièces travaillées, des réglages choisis,...

 <b>a</b>	Niveau de vibration :	Уровень вибрации :	5,993 m / s <sup>2</sup>
	Hand/arm vibration level :	Titreşim seviyesi :	
	Vibrationspegel Hand/Arm :	Úroveň vibrací :	
	Nivel de vibración mano/brazo :	Hladina vibrácií :	
	Livello di vibrazione mano/braccio :	Vibrasjonsnivå:	
	Nível de vibração mão/braço :	مستوى الارتجاج.	
	Trillingsniveau hand/arm :	Vibrációsintzint :	
	ΕΠΙΠΤΕΔΟ ΚΡΑΔΑΣΜΩΝ:	Nivo vibracij :	
	Poziom wibracji rżka/ramię :	Равнище :	
	Tärinätaso:	Vibrācijas līmenis.	
Vibrationsnivå hand/arm :	Vibrācijas lygis		
Vibrationsniveau :	Vibratsiooni nivo		
Nivel vibratii :	Razina vibracije:		

VIBRATIONS:

Total des valeurs de vibration (somme vectorielle des trois directions) déterminée selon EN 60745 :

a 5,993 m/s<sup>2</sup>  
Incertitude K 1,5 m/s<sup>2</sup>

L'amplitude d'oscillation peut être utilisée comme valeur de comparaison d'outils électroportatifs.  
Attention : si l'outil électroportatif est utilisé pour d'autres applications, avec d'autres outils de travail, l'amplitude d'oscillation peut être différente.





	<p>Porter des lunettes de sécurité : Wear protective eyewear : Schutzbrille tragen : Llevar puestas gafas protectoras : Portare de gli occhiali di sicurezza : Utilizar óculos de segurança : Draag een veiligheidsbril : ΦΟΡΑΤΕ ΠΡΟΣΤΑΤΕΥΤΙΚΑ ΓΥΑΛΙΑ: Zakładać okulary ochronne : Käytä suojalaseja : Använd skyddsglasögon : Der skal benyttes sikkerhedsbriller : Purtati ochelari de protectie :</p>	<p>Наденьте защитные очки : Güvenlik gözlükleri takın : Používejte bezpečnostní brýle : Noste ochranné okuliare : Bruk vernebriller: حامل نظارات وقائية. Viseljen védőszemüveget : Nositi zaščitna očala : Да се използват защитни очила : Kandke kaitseprille Nešioti apsauginius akinius Valkät aizsargbrilles Nositi zaštitne naočale:</p>	×
---	--	---	---

	<p>Porter un masque anti-poussière : Wear a dust mask : Staubschutzmaske tragen : Llevar puesta una careta de protección contra el polvo : Indossare una mascherina anti-polvere : Utilizar uma máscara anti-poeira : Draag een stofmasker : ΦΟΡΕΣΤΕ ΜΑΣΚΑ ΓΙΑ ΤΗ ΣΚΟΝΗ: Zakładać maskę przeciwpylową Käytä pölysuojust : Bär mask mot damm : Der skal benyttes beskyttelsesmaske mod støv: Purtati mască anti-praf :</p>	<p>Наденьте респиратор : Toza karşı maske takın : Používejte masku proti prachu : Noste ochrannú masku proti prachu : Bruk en støvmaske: لبس قناع حفاض للغباب. Viseljen porvédő maszkot Nositi zaščitno masko proti prahu: Да се използва защитна маска : Kandke tolmumaski. Dëvëti respiratorių Valkät aizsarg masku pret putekljem Nositi masku za zaštitu od prašine:</p>	×
---	---	--	---

	<p>Porter une protection auditive : Wear hearing protective equipment: Gehörschutz tragen: Llevar puesta una protección auditiva: Portare una protezione uditiva: Utilizar uma protecção auditiva: Draag gehoorbeschermers: ΦΟΡΑΤΕ ΠΡΟΣΤΑΣΙΑ ΑΚΟΗΣ: Zakładać słuchawki ochronne Käytä kuulosuojaimia: Bär hörselskydd: Der skal benyttes høreværn: Purtati căști de protecție auz:</p>	<p>наденьте средства звуковой защиты: İşitsel koruma aleti takın: Používejte ochranu sluchu: Noste ochranné slúchadlá: Bruk hørselsvern: لبس خوذة خوض الخصىج Viseljen fülvédőt Nositi zašito ušes: Да се използва слухови защитни средства: Kandke kõrvakaitset Nešioti apsaugą nuo triukšmo Valkät dzirdes aizsarglīdzekli Nositi štītņike protiv buke:</p>	×
---	--	--	---

	<p>Porter des gants : Use rubber gloves : Schutzhandschuhe tragen : Llevar guantes de protección : Indossare i guanti di protezione : Utilizar luvas de protecção : Draag veiligheidshandschoenen : ΦΟΡΩΝΤΑΣ ΓΑΝΤΙΑ: Używać rękawic ochronnych : Käytä suojakäsineitä : Använd skyddshandskar : Der skal benyttes handsker : Purtati mănuși :</p>	<p>Наденьте перчатки : Eldiven takın : Noste rukavice : Noste rukavice : Bruk hansker: لبس قفازات. Viseljen kesztyű t Nositi rokavice: а се използват предпазни ръкавици : Kandke kindaid Müvëti pirštines Valkät cimduš Nositi zaštitne rukavice:</p>	×
---	---	--	---





	<p>Conformité européenne          Conforms to EC standards :          CE-Konformität :          Cumples con las directivas CE :          Conforme alle norme CE :          Conforme às normas CE :          Voldoet aan de EG-normen :          ΕΥΡΩΠΑΪΚΗ ΣΥΜΜΟΡΦΩΣΗ          Zgodność z normami CE :          EU-standardien mukainen :          EU-standardien mukainen :          Overholder EU standarderne :          Conform cu normele europene:</p>	<p>соответствие европейским стандартам:          Avrupa uygunluk :          evropská shoda :          európska dohoda :          Europeisk konformitet          مطابق للجواصفات الأوروبية.          evropska ustreznost :          európai megfeleléség :          Съответствие с европейските норми :          Euroopa Liidu vastavusmärk          Europinių normų atitikima          Atbilstība Eiropas standartiem          Euroopska sukladnost</p>	<p>×</p>
---	---	---	----------

	<p>Lire les instructions avant usage :          Read the instructions before use :          Vor Einsatz des Geräts Anweisung lesen :          Léase las instrucciones antes de usar :          Leggere le istruzioni prima dell'uso :          Ler as instruções antes da utilização :          Lees voor het gebruik de instructies :          ΔΙΑΒΑΣΤΕ ΤΙΣ ΟΔΗΓΙΕΣ ΠΡΙΝ ΑΠΟ ΤΗ ΧΡΗΣΗ:          Zapoznać się instrukcją przed użyciem :          Lue ohjeet ennen käyttöä :          Läs anvisningarna före användning :          læs instruktionerne før brug          Înainte de utilizare, citiți instrucțiunile :</p>	<p>Внимательно прочитайте следующие инструкции :          Kullanmadan talimatları okuyunuz :          Pozorně si přečtěte následující pokyny :          Pred použitím si prečítajte pokyny :          Les bruksanvisningen før bruk:          اقرأ التعليمات قبل الاستخدام.          használat előtt olvassuk el az utasítást :          Pred uporabo preberite ustrezna navodila          Прочетете указанията за употреба :          Enne kasutamist lugege instruksiooni          Prieš naudojimą perskaityti instrukciją          izlasīt instrukcijas pirms lietošanas          Pročitati upute prije uporabe:</p>	<p>×</p>
---	--	---	----------

	<p>Danger :          Danger :          Gefahr :          Peligro :          Pericolo :          Perigo :          Gevaar :          ΚΙΝΔΥΝΟΣ:          Niebezpieczeństwo :          Vaara :          Fara :          Fare :          Pericol :</p>	<p>Опасно :          Tehlike :          Nebezpečí :          Nebezpečnost :          Fare:          خطر.          Veszély :          Nevarnost:          Опасност :          Oht          Pavojus          Bistamība          Opasnost:</p>	<p>×</p>
---	--	---	----------

	<p>Classe d'isolement : 2          Insulation class : 2          Isolierklasse: 2          Aislamiento clase :2          Isolamento classe :2          Isolamento classe :2          Isolatie Klasse : 2          ΚΑΤΗΓΟΡΙΑ ΜΟΝΩΣΗΣ: 2          Izolacija Klasy :2          Eristysluokka :2          Isolering Klass :2          Isoleringsklasse 2          Clasă izolație :2</p>	<p>Класс изоляции 2 :          Yalıtım derecesi :2          Třída izolace :2          Izolačný systém 2          Isolasjonsklasse: 2          فئة العزل 2.          Szigetelési osztály :2          Razred izolacije :2          Инструмент Клас :2          Isolatsiooniklass 2          Izolācijas rūšis 2          Izolācijas klase 2          Izolacija klasa: 2</p>	<p>×</p>
---	---	--	----------

<p>IP 20</p>		<p>×</p>
--------------	--	----------





	<p>Soumis à recyclage Subjected to recycling Sujeto a reciclaje Sottoposti a riciclaggio Sujeitos à reciclagem Não deite no lixo : Niet wegwerpen : ΥΠΟΚΕΙΤΑΙ ΣΕ ΑΝΑΚΥΚΛΩΣΗ Nie wyrzucac : Älä heittää pois luontoon : Batteriet får inte kastas : Bortkast det ikke: Nu le auncati :</p>	<p>Подлежит переработке Atmayınız : Nevyhadzujte je do bežného odpadu : Neodhadzovat : Gjenvinningspliktig فلا ترحمه هالذا في القمامة. ne mečíte! Ne odvržite ga/jih vstran : Taaskasutusse kuuluv Ärge visake seda minema : Nemétykíte : Nemest : Podvrgnuto recikliranju</p>	×
---	---	--	---

**Recyclage des déchets :**

Les outils, accessoires et leur emballages doivent suivre une voie de recyclage adaptée. Conformément aux directives Européenne 2012/19/UE et 2006/66/CE, les composants d'un produit doivent être séparés, collectés, recyclés ou éliminés en conformité avec les réglementations environnementales en vigueur. Les appareils, batteries, piles, huiles, emballages devront être déposés dans les systèmes d'élimination des déchets spéciaux tels que déchetteries. Renseignez-vous auprès de votre commune pour connaître l'organisme le plus proche à même de retraiter ou de collecter ces déchets.

	<p>Recyclable, soumis au tri sélectif Recyclable, subject to recycling Recyclingfähige, unterliegen Recycling Reciclables, sujetos a reciclaje Riciclabili, soggetti a riciclaggio Recicláveis, sujeito à reciclagem Recycleerbare, onderworpen aan recycling ΑΝΑΚΥΚΛΩΣΙΜΟ, ΥΠΟΚΕΙΤΑΙ ΣΕ ΕΠΙΛΕΚΤΙΚΗ ΔΙΑΛΟΓΗ Opakowanie nadaje się do recyklingu podlegają recyklingu Kierrätettävien pakkausten kohteena kierrätys Återvinningsbara förpackningar omfattas återvinning Рециклираци се опаковки подлежат на рециклиране Genanvendelig underlagt genbrug</p>	<p>Reciclabile sub rezerva reciclare Повторно упаковка подлежит вторичной переработке Geri dönüştürme Geri dönüştürülebilir ambalaj konusu Recyklovateľné podléhajúci recyklácii Recyklovateľné podliehajúce recyklácii Resirkulerbar, med forbehold om selektiv sortering ريودنلا خا مال عيش ريويدنلا خا مال لباؤلا فحول يئلا و توب يئلا Újrahasznosítható csomagolás alá újrahasznosítás Reciklirati predmet recikliranja Pakendite suhtes ringlussevõtu Pärsträdājams iepakojumus otrreizējai pārstrādei Perdirbamų taikomos perdirbimo Može se reciklirati, podložno selektivnom sortiranju</p>	×
---	--	---	---





PM 6C

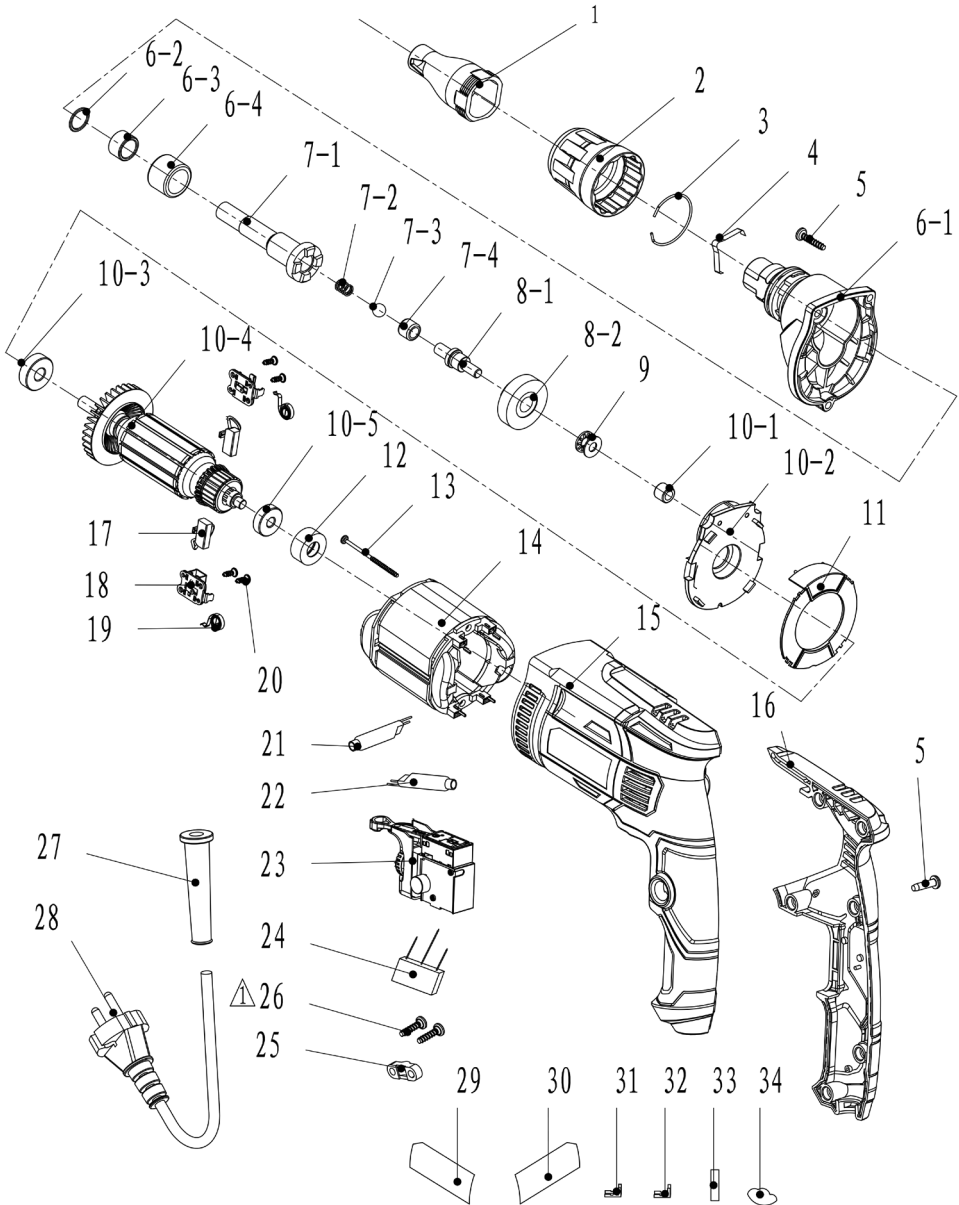









**FAR GROUP EUROPE**  
 192, Avenue Yves Farge  
 37700 St. Pierre-des-Corps  
 FRANCE  
*Serial number / numéro série :*

PM 6C      115009      R8502A

115009-3-Sticker-F-01-Logo.indd 1      03/11/2022 15:47

Made in P.R.C.

 230V-50Hz   
  520 W   
  0-4200 min<sup>-1</sup>   
  1,60 kg



115009-3-Sticker-F-02-Normes.indd 1      10/10/2022 15:47





DECLARATION DE CONFORMITE  
 VERKLARING VAN OVEREENSTEMMING  
 DECLARACION DE CONFORMIDAD  
 DICHIARAZIONE DI CONFORMITA  
 KONFORMITÄSERKLÄRUNG  
 DECLARATION CONFORMITY  
 DECLARAÇÃO DE CONFORMIDADE  
 DEKLARACJA ZGODNOSCI Z NORMAMI  
 OM ÖVERENSSTÄMMELSE  
 VAATIMUSTENMUKAISUUSVAKUUTUS  
 ÖVERENSSTEMMELSESERKLÄRING  
 ΔΗΛΩΣΗ ΣΥΜΜΟΡΦΩΣΗΣ

DECLARAȚIE DE CONFORMITATE  
 VYHLÁSENIE ZHODY  
 Декларация соответствия  
**SAMSVARERKLÆRING**  
 Uygunluk beyanı  
 التصريح بالامتثال  
 PROHLÁSENÍ SHODY  
 EGYZÖSÉGI NYILATKOZAT  
 Декларация за съответствие с нормите  
**IZJAVA O SKLADNOSTI**  
 DEKLARACIJA  
 ATITIKTES DEKLARACIJA  
 KINNITUS  
**IZJAVA O SUKLADNOSTI**

Le soussigné,  
 Ondergetekende,  
 Der Unterzeichner,  
 O abaixo assinado,  
 Undertecknad,  
 Долуподписаният  
 Undertegnede  
 Subseminatul,  
 Я, нижеподписавшийся,  
 Imzalamay,  
 Niže podepsany,  
 Toliau pasirašęs

Personne autorisée à constituer  
 le dossier technique :  
 Christophe HUREL



FAR GROUP EUROPE  
 192, Avenue Yves Farge  
 37700 St. Pierre-des-Corps  
 FRANCE

El suscrito,  
 Il sottoscritto,  
 The undersigned,  
 Ninej podpišany  
 Allekirjoittanut,  
 Ο ΚΑΤΩΘΙ ΥΠΟΤΕΓΡΑΜΜΕΝΟΣ,  
 Nižšie podpísany  
 Undertegnede,  
 الحقوق اءزاء  
 Alulírott,  
 Podpisani,  
 Apakša parakstijies  
 atakirjutanu  
 Dolje potpisani,

Declaro por la presente, que,  
 Dichiare che,  
 Declares that,  
 Oświadczam niniejszym, że  
 Ilmoittaan täten että,  
 ΔΙΑ ΤΟΥ ΠΑΡΟΝΤΟΣ ΔΗΛΩΝΕΙ ΟΤΙ,  
 týmto vyhlásuje, že  
 Erklærer herved at,  
 Kijeleñtem, hoğy a kësüzék Izjavlja da,  
 Pareiškia, kad,  
 Ar šo apliecinā, ka,  
 Kinnitab, et  
 Izjavljuje u ovom dokumentu da je

Déclare par la présente que,  
 Verklaart hiermede dat,  
 Erklårt hiermit daß,  
 Declara pela presente que,  
 Förklarar härmed att  
 Заявява с настоящото  
 erklærer hermed, at  
 Declar prin prezenta că,  
 настоящим подтверждаю, что  
 Mecut belgeye beyan edilyor ki,  
 timto prohlasuje, ze,  
 Pareiškia, kad,

Visseuse à placoplâtre / Plasterboard screw inserter / Gipsplattenschrauber / Atornillador para placas de yeso / Avvitatrice per cartongesso / Aparafusadora para gesso / Schroevendraaier voor gipsplaat / Μηχανή βιδώματος για πλάκες γύψου / Wkretarka do płyt kartonowo-gipsowych / Laastin ruuvaava porakone / Skruvdragare för gipsskivor / Skruemaskine til gipsplader / Машина за завинтане с гипсова фурнирна облицовка / Maşină de însurubat pentru gips-carton / Шурупверт для гипсокартона / Elektriکی vidalama makinası / Uzaviračka pro sadru / Uzatvárač na sadru / סימלה הרבנו / یی آبرمک لغم / Gipskarton csavarozó / Vijačnik za mavčne plošče / Kruvikeeraja kipsmaterjalidele / Apmetuma plākšņu skrūvgriezis / Gipsinis tvirtinimo aparatas

**code**

FARTOOLS / 115009 / PM 6C / R8502A

**Est conforme et satisfait aux directives et normes CE,**  
 In overeenstemming is met en Voldoet aan EG richtlijnen,  
 Den folgenden EU-Bestimmungen entspricht,  
 Respeita e está em conformidade com as normas CE,  
 Överensstämmer med och uppfyller EG-standarder,  
 Съответства и отговаря европейските норми  
 Er i overensstemmelse med og overholder EU standarderne  
 Este conform și satisface normele CE  
 полностью соответствует и удовлетворяет  
 требованиям стандартов ЕС  
 CE şartlara uygundur,  
 odpovídá normám ES,  
 Atitinka ir atitinka EB direktyvas ir standartus,

Cumple con la directivas de la CE,  
 E conforme alle direttive CEE,  
 Complies with the EEC directives and standards,  
 Odpowiada normom UE,  
 Täyttää EU-vaatimukset,  
 ΣΥΜΜΟΡΦΩΝΕΤΑΙ ΚΑΙ ΙΚΑΝΟΠΟΙΕΙ ΤΙΣ ΟΔΗΓΙΕΣ ΚΑΙ ΤΑ ΠΡΟΤΥΠΑ CE,  
 zodpovedá normám ES,  
 Samsvarer med og tilfredsstiller CE-direktiver og standarder,  
 ہے ان کے مطابق و یابی مع ای یی مع جو عہ الدول الأوروبیة  
 kieleğiti a CE szabványok előírásait.  
 Je v skladu z in izpolnjuje norme Evropske skupnosti.  
 Atbilst un atbilst EK direktīvas un standartus.  
 Vastab ja vastab EU direktīviudele ja standarditele,  
 Sukladan i ispunjava direktive i standarde CE,

2006/42/EC 2014/30/EU 2011/65/EU&2015/863/EU

EN IEC 55014-1:2021  
 EN IEC 55014-2:2021

EN IEC 61000-3-2:2019/A2:2011  
 EN 61000-3-3:2013/A2:2021  
 EN 62841-1:2015/A11:2022  
 EN 62841-2-2:2014

Christophe HUREL,  
 Président Directeur Général  
 01/04/2025  
 Fait à St. Pierre-des-Corps



## GARANTIE - WARRANTY



### FR. GARANTIE

Cet outil est garanti contractuellement contre tout vice de construction et de matière, à compter de la date de vente à l'utilisateur et sur simple présentation du ticket de caisse. La garantie consiste à remplacer les parties défectueuses. Cette garantie n'est pas applicable en cas d'exploitation non conforme aux normes de l'appareil, ni en cas de dommages causés par des interventions non autorisées ou par négligence de la part de l'acheteur. La garantie ne s'applique pas sur les dommages causés par une défaillance de l'outil.

### DE. GARANTIE

Die Garantiezeit für dieses Gerät in bezug auf Konstruktions- und Materialfehler beträgt lt. Vertrag bei Vorlage des Kassensbons. Die Garantieleistung besteht im Ersatz schadhafter Teile. Die Garantie erlischt bei einem Einsatz des Geräts, der nicht normentsprechend ist, bei Schäden, die auf unsachgemäße Eingriffe zurückzuführen sind bzw. bei Nachlässigkeit seitens des Käufers. Die Garantie erstreckt sich nicht auf Schäden, die auf Fehlfunktionen des Geräts zurückzuführen sind.

### IT. GARANZIA

Quest' attrezzo è garantito per contratto contro qualsiasi difetto di costruzione e di materia, a partire dalla data di vendita all'utente e su semplice presentazione dello scontrino. La garanzia consiste nel sostituire le parti difettose. Questa garanzia non è applicabile in caso di sfruttamento non conforme alle norme dell'apparecchio, né in caso di danni causati da interventi non autorizzati o da negligenza da parte dell'acquirente. La garanzia non si applica ai danni causati da un'avarìa dell'attrezzo.

### EN. GARANTIE

This tool is guaranteed, in writing, against any defect in manufacture or parts from the date of sale, upon simple presentation of the sales slip. The guarantee is limited to the replacement of faulty parts. This guarantee is not applicable in the event of usage which is not conform with the intended usage of the apparatus, nor in the event of damage caused by unauthorised servicing or negligence on behalf of the purchaser. This guarantee does not apply to any damage caused by the failure of this tool.

### ES. GARANTIA

Esta herramienta se garantiza contractualmente contra todo defecto de construcción y materia, a partir de la fecha de venta a l' usuario y sobre simple presentación del recibo de caja. La garantía consiste en sustituir a las partes defectuosas. Esta garantía no es aplicable en caso de explotación no conforme a las normas del aparato, ni en caso de danos causados por intervenciones no autorizadas o por negligencia por parte del comprador. La garantía no se aplica sobre los danos causados por un fallo del herramienta.

### NL. GARANTIE

Dit gereedschap heeft een garantie tegen constructiefouten en materiaaldefecten, die geldig is vanaf de aankoopdatum door de gebruiker, op vertoning van de kassabon. De garantie betreft de vervanging van de defecte onderdelen. Deze garantie is niet van toepassing indien het apparaat niet volgens de normen gebruikt is, noch in geval van schade veroorzaakt door ongewenst gebruik of nalatigheid van de koper. De garantie is niet van toepassing op schade voortvloeiend uit een defect van het gereedschap.

### PT. GARANTIA

Esta ferramenta tem uma garantia contratual contra qualquer defeito de construção e de material, a partir da data de venda ao utilizador e sobre simples apresentação do talão da caixa. A garantia consiste em substituir as partes defeituosas. Esta garantia não é aplicável no caso de exploração não conforme as normas do aparelho, nem em caso de danos causados pelas intervenções não autorizadas ou por negligência da parte do comprador. A garantia não se aplica para os danos causados por uma falha da ferramenta.

### EL. ΕΓΓΥΗΣΗ

ΑΥΤΟ ΤΟ ΕΡΓΑΛΕΙΟ ΕΙΝΑΙ ΣΥΜΒΑΤΙΚΑ ΕΓΓΥΗΜΕΝΟ ΓΙΑ ΟΠΟΙΟΔΗΠΟΤΕ ΚΑΤΑΣΚΕΥΑΣΤΙΚΟ ΚΑΙ ΥΛΙΚΟ ΕΛΑΤΤΩΜΑ, ΑΠΟ ΤΗΝ ΗΜΕΡΟΜΗΝΙΑ ΠΩΛΗΣΗΣ ΣΤΟΝ ΧΡΗΣΤΗ ΚΑΙ ΜΕ ΤΗΝ ΕΠΙΔΕΙΞΗ ΤΗΣ ΑΠΟΔΕΙΞΗΣ ΠΩΛΗΣΗΣ. Η ΕΓΓΥΗΣΗ ΣΥΝΙΣΤΑΤΑΙ ΣΤΗΝ ΑΝΤΙΚΑΤΑΣΤΑΣΗ ΤΩΝ ΕΛΑΤΤΩΜΑΤΙΚΩΝ ΕΞΑΡΤΗΜΑΤΩΝ. ΑΥΤΗ Η ΕΓΓΥΗΣΗ ΔΕΝ ΙΣΧΥΕΙ ΣΕ ΠΕΡΙΠΤΩΣΗ ΛΕΙΤΟΥΡΓΙΑΣ ΠΟΥ ΔΕΝ ΣΥΜΜΟΡΦΩΝΕΤΑΙ ΜΕ ΤΑ ΠΡΟΤΥΠΑ ΤΗΣ ΣΥΣΚΕΥΗΣ, ΟΥΤΕ ΣΕ ΠΕΡΙΠΤΩΣΗ ΖΗΜΙΑΣ ΠΟΥ ΠΡΟΚΑΛΕΙΤΑΙ ΑΠΟ ΜΗ ΕΥΣΥΙΟΔΟΤΗΜΕΝΕΣ ΕΠΕΜΒΑΣΕΙΣ Ή ΑΜΕΛΕΙΑ ΕΚ ΜΕΡΟΥΣ ΤΟΥ ΑΓΟΡΑΣΤΗ. Η ΕΓΓΥΗΣΗ ΔΕΝ ΙΣΧΥΕΙ ΓΙΑ ΖΗΜΙΕΣ ΠΟΥ ΠΡΟΚΑΛΟΥΝΤΑΙ ΑΠΟ ΑΣΤΟΧΙΑ ΕΡΓΑΛΕΙΟΥ.

### PL. GWARANCJA

Narz dzie jest obje te gwarancja w wszelkie wady konstrukcyjne i materialowe, liczac od daty

sprzedaży u użytkownikowi i po okazaniu paragonu kasowego. Gwarancja obejmuje wymianę cz. ACI wybrakowanych. Gwarancja nie znajduje zastosowania w przypadku użycowania niezgodnego z normami urzadzzenia, ani w przypadku szkód spowodowanych działaniami niedozwolonymi lub zaniedbaniami ze strony nabywcy. Gwarancja nie obejmuje szkód powstałych z powodu upadku urzadzzenia.

### SV. GARANTI

Detta verktyg har en avtalsenlig garanti mot konstruktions och materialfel, från och med tidpunkten för användarens inköp och genom uppvisning av kassakvittot. Garantin består i att ersätta de bristfälliga delarna. Denna garanti gäller inte om användningen inte motsvarar apparatens ståndarder, inte heller vid skador som orsakas av ej tillatna ingrepp eller på grund av koparens vårdslöshet. Garantin gäller inte förskador som orsakats av att verktyget fungerat bristfälligt.

### FI. TAKUU

Tämän laitteen takuu on voimassa sopimuksenmukaisesti kattaa kaikki rakenne- ja materiaaliiviat lukien ostopaivasta, kassakuitilla vastaan. Takuu sisältää viallisten osien korvaamisen. Takuu ei korvaa ohjeiden vastaista käyttöä eikä vialtuuttamattomien henkilöiden kasittelystä tai ostajan huolimattomuudesta aiheutuneita vahinkoja. Takuu ei vastaa myöskään toimintahairiosta aiheutuneita vahinkoja.

### BU. Гаранция

Този инструмент е под договорна гаранция срещу всякакъв дефект в изработката и използваните материали, считано от датата на продажба на потребителя и само срещу представяне на касовата бележка. Гаранционното обслужване се състои в замяна на дефектните части. Настоящата гаранция не е валидна когато апаратът се използва по начин, несъответстващ на стандарта за работа с него, както и в случай на щети, нанесени от неотуризирани лица, или вследствие на проявена небрежност от страна потребителя.

Гаранцията не покрива щети, произтекли вследствие на техническа неизправност на апарата.

### DA. GARANTI

Dette værktøj er dækket af en garantikontrakt for konstruktions- og materialefej, som gælder fra købsdatoen ved visning af kassabon. Garantien består i at udskifte de defekte dele. Garantien dækker ikke fejl opstået som følge af anvendelse, som ikke overholder standarderne for apparatet, eller

## SERVICE APRÈS VENTE - AFTER SALE SERVICE

FARGROUP EUROPE - 192, Avenue Yves Farge - 37700 St. Pierre-des-Corps - FRANCE

fargroup@fargroup.net





## FAR GROUP EUROPE

Une société du groupe **SIGMA**

192, Avenue Yves Farge  
37700 St. Pierre-des-Corps  
FRANCE

[fartools.com](http://fartools.com)

