

FAR TOOLS®

FR	Rénovateur de précision (Notice originale)
EN	Accuracy renovator (Original manual translation)
DE	Renovator Genauigkeit (Übersetzung aus dem Original-Anleitung)
ES	Exactitud renovador (Traducción del manual de instrucciones original)
IT	Precisione Renovator (Traduzione dell'avvertenza originale)
PT	Exatidão Renovador (Tradução do livro de instruções original)
NL	Nauwkeurigheid Renovator (Vertaling van de originele instructies)
EL	Ακρίβεια ανακαινιστής (Μετάφραση από τις πρωτότυπες οδηγίες)
PL	Dokładność Odnowiciel (Tłumaczenie z oryginalnej instrukcji)
FI	Renovator tarkkuus (Käännös alkuperäisestä ohjeet)
SV	Renovator noggrannhet (Översättning från originalinstruktioner)
BU	Точност обновител (Превод на оригиналната инструкция)
DA	Renovator nøjagtighed (Oversættelse fra oprindelige brugsanvisning)
RO	Precizie renovator (Traducere din instrucțiunile originale)
RU	Точность Реноватор (Перевод с оригинальной инструкции)
TU	Renovator doğruluğu (Orijinal talimatlar çeviri)
CS	Přesnost renovátor (Překlad z originálního návodu)
SK	Presnosť renovátor (Preklad z originálneho návodu)
HE	תורוקמ תוארהמ סוגרת) קינצופיש קויד
AR	تدق لصأأأ تامقعلتلا نم قمجرتلا) حلصم ققد
HU	Renovator pontosság (Fordítás az eredeti utasítások)
SL	Natančnost Obnovilac (Prevod iz izvirnih navodil)
ET	Renoveerija täpsus (Tõlge originaal juhiseid)
LV	Atnaujintojas tikslumas (Tulkojumā no instrukcijas oriģinālvalodā)
LT	Atjaunotājs precizitāte (Vertimas iš originalių instrukcijos)
HR	Preciznost osvježavač (Prijevod prema originalne upute)



REX 60
Professional Machine



© FAR GROUP EUROPE

115021-D-20220711



fartools.com



FIG. A



FIG. B





FIG. C

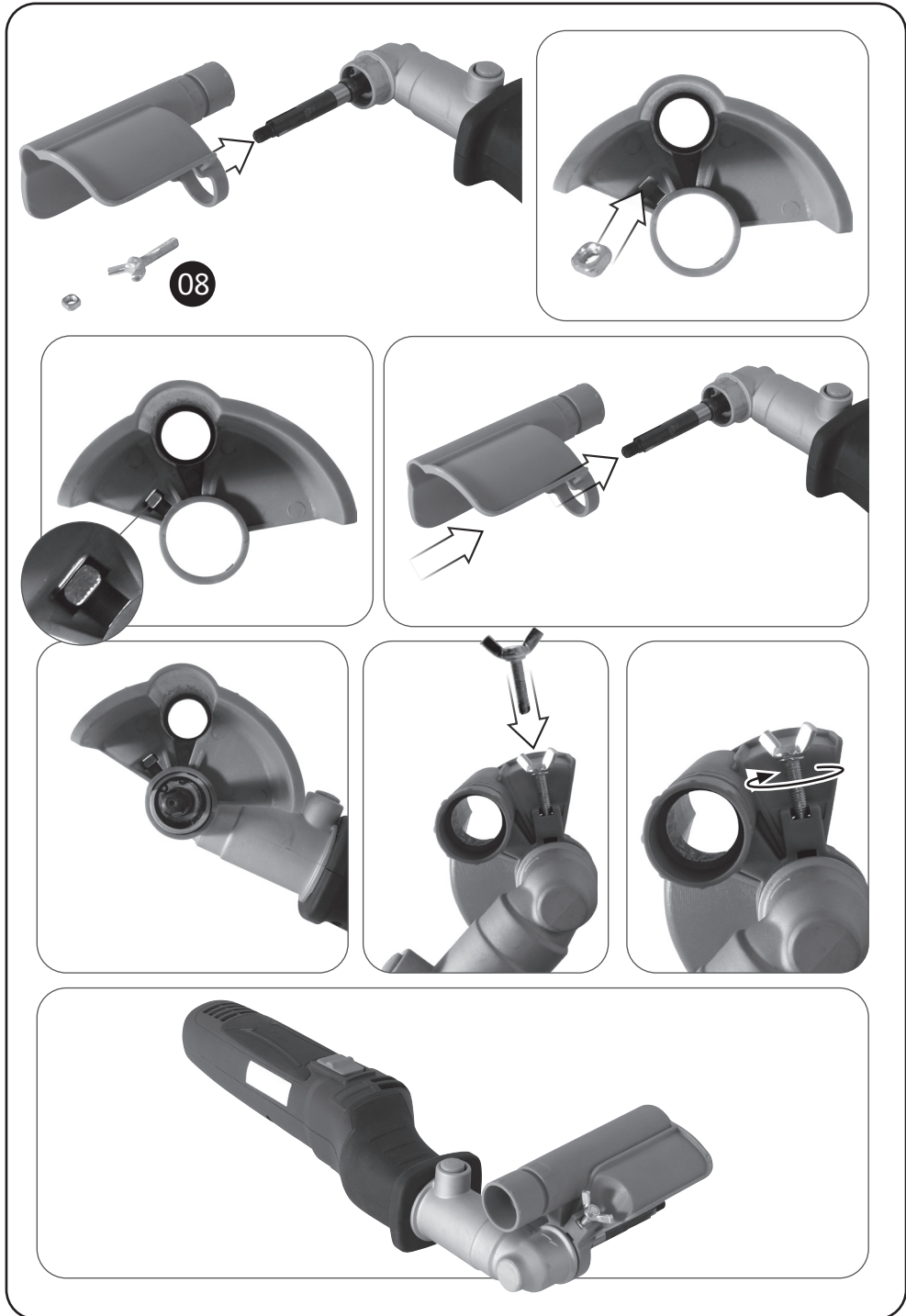



FIG. D

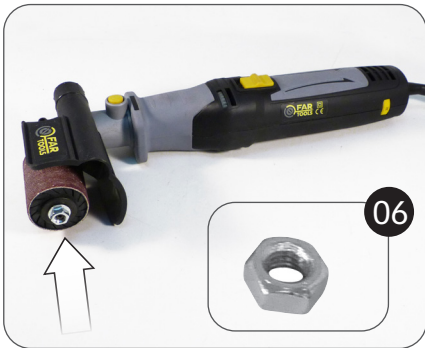
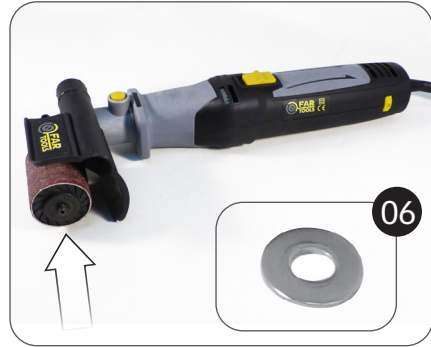



FIG. E

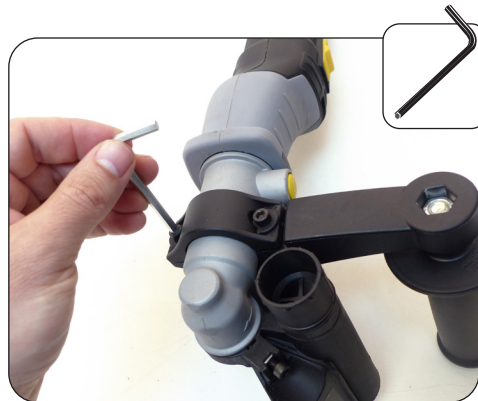
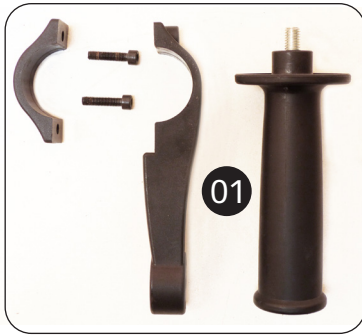
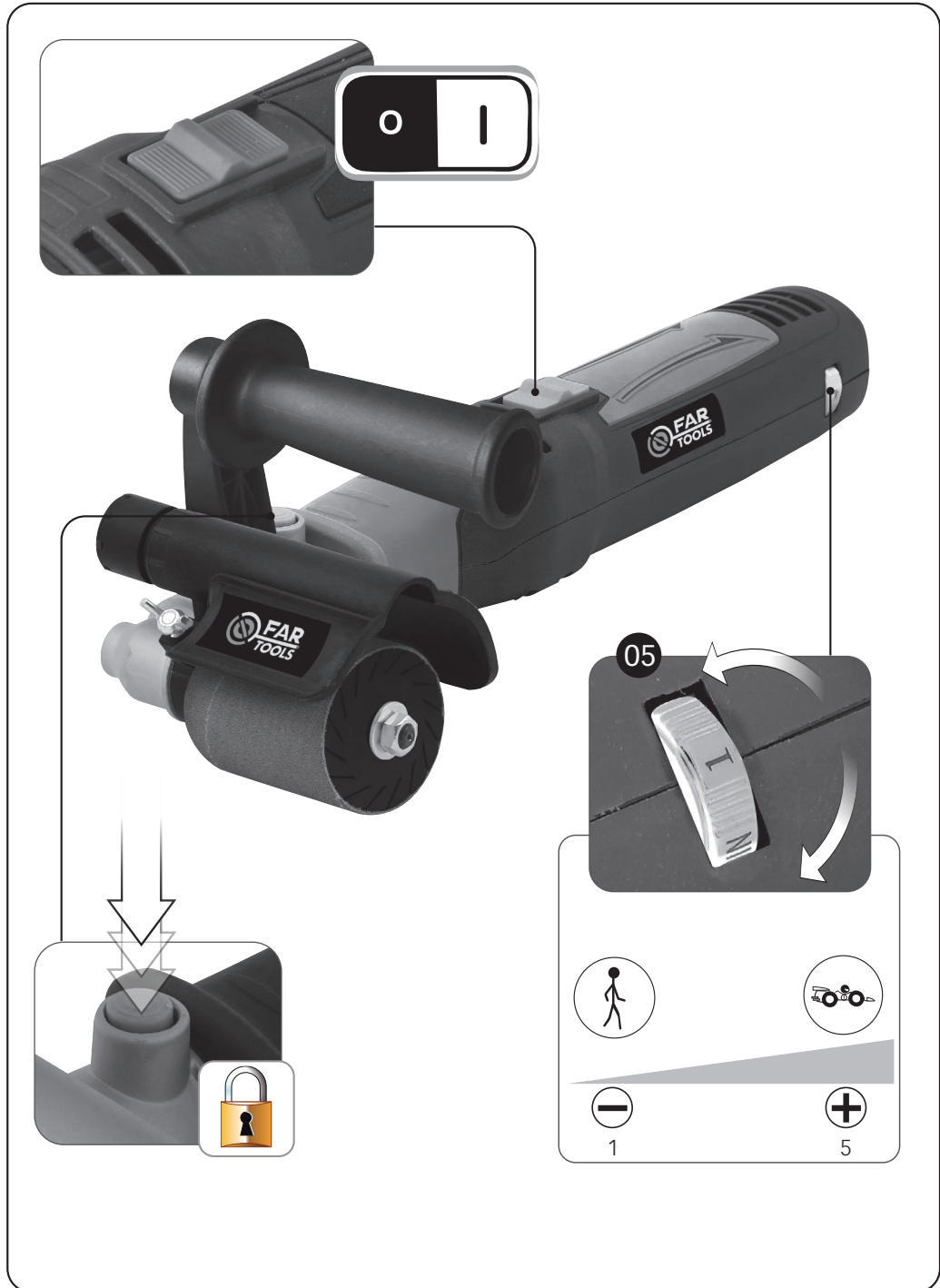



FIG. F





Option / Opción / Opzione / Opção / Opție / Επιλογή / Opcja / Valitoehto / Alternativet /
 Опция / Mulighed / Opțiune / Параметр / Seçeneği / Možnost / ראיגל /
 Lehetőség / Možnost vóimalus / Opciju / Parinktį / Mogućnost



Précaution ! Stockage au sec et à l'abris de la lumière !
 Pozor! Shranjevanje v suhem in zaščiteno pred svetlobo!
 ¡Precaución! Almacenamiento en seco y protegido de la luz!
 Cuidado! Armazenamento em seco e protegido da luz!
 Attenzione! Stoccaggio in luogo asciutto e al riparo dalla luce!
 Caution! Storage in dry and protected from light!





	<p>Tension et fréquence assignée: Nominal frequency and power: Nennspannung und Nennfrequenz : Tensión y frecuencia fijada: Tensione e frequenza assegnata: Tensão e frequência fixa: Aangewezen spanning en frequentie: ΟΝΟΜΑΣΤΙΚΗ ΤΑΣΗ ΚΑΙ ΣΥΧΝΟΤΗΤΑ: Napięcie i częstotliwość przydzielona: Jännite ja määrätty taajuus: Angiven spänning och frekvens: Anført spænding og frekvens: Tensiune și frecvență de lucru:</p>	<p>Заданное напряжение и частота: Tahsis gerilimi ve frekansı: Stanovené napětí a frekvence: Stanovené napätie a frekvencia: Merkespenning og merkefrekvens: الغلطية والذبذب المبرمجة. Névleges feszültség és frekvencia: Napetost in določena frekvenca: Консумирано напрежение и честота : Määratud pinge ja sagedus Nustatyta įtampa ir dažnis Noteiktais spriegums un frekvence. Napon i nazivna frekvencija:</p>	230 V ~ 50 Hz
--	---	---	---------------

	<p>Puissance assignée: Nominal power: Nennleistung: Potencia fijada: Potenza assegnata: Potência assinada: Onbelast toerental: ΟΝΟΜΑΣΤΙΚΗ ΙΣΧΥΣ: Prędkość na biegu jałowym: Teho: Angiven effekt: Anført styrke: Putere de lucru:</p>	<p>Заданная мощность: Tahsis edilen güç: Stanovený výkon: Predpísaný výkon: Merkeeffekt: القدرة المبرمجة. Névleges teljesítmény : Določena jakost: Консумирана мощност: Määratud võimsus. Nustatyta galia Noteiktā jauda Nazivna snaga:</p>	300 W
--	---	---	-------

	<p>Vitesse à vide: No-load speed: Leerlaufdrehzahl: Velocidad vacía: Velocità a vuoto: Velocidade no vácuo: Leerlaufdrehzahl: ΤΑΧΥΤΗΤΑ ΑΔΡΑΝΕΙΑΣ: Prędkość bez obciążenia: Tyhjäkäyntinopeus Tomgångshastighet: Hastighed i ubelastet tilstand: Viteza în gol:</p>	<p>Скорость вращения на холостом ходу: Boşalma hızı: Rychlost naprázdno: Rýchlosť pri chode naprázdno: Tomgångshastighet: السرعة على الفارغ. Üres sebesség: Prosti tek: Скорост на празни обороти: Kiirus tühikäigul Tuščio prietaiso greitis Tukšgaitas ātrums Brzina praznog hoda:</p>	1600 - 3000 min ⁻¹
--	--	--	-------------------------------

	<p>Classe d'isolement : 2 Insulation class : 2 Isolierklasse : 2 Aislamiento clase :2 Isolamento classe :2 Isolamento classe :2 Isolatie Klasse : 2 ΚΑΤΗΓΟΡΙΑ ΜΩΝΩΣΗΣ : 2 Izolacja Klasy :2 Eristysluokka :2 Isolering Klass :2 Isoleringsklasse 2 Clasă izolație :2</p>	<p>Класс изоляции 2 : Yalitim derecesi :2 Třída izolace :2 Izolačný systém 2 Isolasjonsklasse: 2 فئة العزل 2. Szigetelési osztály :2 Razred izolacije :2 Инструмент Клас :2 Isolatsiooniklass 2 Izolācijas rūšis 2 Izolācijas klase 2 Izolacija klasa: 2</p>	X
--	--	--	---





	Poids :	Bec :	1,91 kg
	Weight :	Ağırlık :	
	Gewicht :	Hmotnost :	
	Peso :	Hmotnosť :	
	Peso :	Vekt:	
	Peso :	الوزن:	
	Gewicht :	Súly :	
	ΒΑΡΟΣ :	Teža :	
	Masa :	Терло :	
	Paino :	Raskus	
	Vikt :	Svoris	
	Vægt :	Svars	
	Greutate :	Težina	

	Lire les instructions avant usage :	Внимательно прочитайте следующие инструкции :	X
	Read the instructions before use :	Kullanmadan talimatları okuyunuz :	
	Vor Einsatz des Geräts Anweisung lesen :	Pozorně si přečtete následující pokyny :	
	Léase las instrucciones antes de usar :	Pred použitím si prečítajte pokyny :	
	Leggere le istruzioni prima dell'uso :	Les bruksanvisningen før bruk:	
	Ler as instruções antes da utilização :	اقرأ التعليمات قبل الاستخدام:	
	Lees voor het gebruik de instructies :	használat előtt olvassuk el az utasítást :	
	ΔΙΑΒΑΣΤΕ ΤΙΣ ΟΔΗΓΙΕΣ ΠΡΙΝ ΑΠΟ ΤΗ ΧΡΗΣΗ:	Pred uporabo preberite ustrezna navodila	
	Zapoznać się instrukcją przed użyciem :	Прочетете указанията за употреба :	
	Lue ohjeet ennen käyttöä :	Enne kasutamist lugege instruksiooni	
	Läs anvisningarna före användning :	Priēš naudojimą perskaityti instrukciją	
	læs instruktionerne før brug	izlasīt instrukcijas pirms lietošanas	
	Înainte de utilizare, cititi instructiunile :	Pročitati upute prije uporabe:	

	Conformité européenne	соответствие европейским стандартам:	X
	Conforms to EC standards :	Avrupa uygunluk :	
	CE-Konformität :	evropská shoda :	
	Cumple con las directivas CE :	európska dohoda :	
	Conforme alle norme CE :	Europeisk konformitet	
	Conforme às normas CE :	قطابق للجواصفات الأوروبية:	
	Voldoet aan de EG-normen :	evropska ustreznost :	
	ΕΥΡΩΠΑΪΚΗ ΣΥΜΜΟΡΦΩΣΗ	európai megfelelőség :	
	Zgodność z normami CE :	Съответствие с европейските норми :	
	EU-standardien mukainen :	Euroopa Liidu vastavusmärk	
	EU-standardien mukainen :	Europinių normų atitikima	
	Overholder EU standarderne :	Atbilstība Eiropas standartiem	
	Conform cu normele europene:	Evropska sukladnost	

	Danger :	Опасно :	X
	Danger :	Tehlike :	
	Gefahr :	Nebezpečí :	
	Peligro :	Nebezpečnost :	
	Pericolo :	Fare:	
	Perigo :	خطر:	
	Gevaar :	Veszély :	
	ΚΙΝΔΥΝΟΣ:	Nevarnost:	
	Niebezpieczeństwo :	Опасност :	
	Vaara :	Oht	
	Fara :	Pavojus	
	Fare :	Bīstamība	
	Pericol :	Opasnost:	





	Diamètre de brosse et alésage : Diameter of wheel and bore : Durchmesser der Trennscheibe und Bohrung : Diámetro del disco y calibre : Diametro del disco e alesaggio : Diâmetro do disco e calibre : Diameter van de schijf en boorgat : ΔΙΑΜΕΤΡΟ ΔΙΣΚΟΥ : Srednica tarczy i otwór : Leikkuuterän läpimitta ja kalviminen : Skivans diameter och innerdiameter : Skivens ydre og indre diameter : Diametru disc și alezaj :	Диаметр диска и пропила : Disk ve delik çapı : Průměr kotouče a vrtání : Priemer kotúča a vnútorný priemer : קוטר הדיסקה וקידוד قطر الأسطوانة والتمهيد A tárcsa és a furat mérete : Premer diska in izvirtine : Диаметр на резеца : Ketta ja puurimise diameeter : Skersmuo : Diska un caurplūdes atvērums diametrs : Promjer četke i dosaditi :	ø 60 mm
--	--	--	---------

IP 20	X
-------	---

- Cet appareil n'est pas prévu pour être utilisé par des personnes (y compris les enfants) dont les capacités physiques, sensorielles ou mentales sont réduites, ou des personnes dénuées d'expérience ou de connaissance, sauf si elles ont pu bénéficier, par l'intermédiaire d'une personne responsable de leur sécurité, d'une surveillance ou d'instructions préalables concernant l'utilisation de l'appareil.
- Il convient de surveiller les enfants pour s'assurer qu'ils ne jouent pas avec l'appareil.
- Dit product is niet bedoeld voor gebruik door personen (inclusief kinderen) met een lichamelijke, zintuiglijke of geestelijke vermogens, of gebrek aan ervaring of kennis, tenzij ze zijn gegeven door door een persoon die verantwoordelijk is voor hun veiligheid, toezicht of instructies over het gebruik van het apparaat.
- Het moet toezicht houden op kinderen om ervoor te zorgen dat zij niet met het apparaat spelen.
- This product is not intended for use by persons (including children) with physical, sensory or mental capabilities, or lack of experience or knowledge, unless they have been given by through a person responsible for their safety, supervision or instruction concerning use of the device.
- It should supervise children to ensure they do not play with the device.
- Este producto no está diseñado para ser utilizado por personas (incluidos niños) con capacidades físicas, sensoriales o mentales, o la falta de experiencia o conocimiento, a menos que hayan sido dadas por través de una persona responsable de su seguridad, supervisión o instrucciones relativas al uso del dispositivo.
- Se debe supervisar a los niños para asegurarse de que no jueguen con el dispositivo.
- Este produto não é destinado ao uso por pessoas (incluindo crianças) com capacidades físicas, sensoriais ou mentais, o falta de experiência ou conhecimento, a menos que tenham sido dadas por através de uma pessoa responsável pela sua segurança, supervisão ou instruções relativas à utilização do dispositivo.
- Deve vigiar as crianças para garantir que eles não brincam com o dispositivo.





 L_{pA}	Niveau de pression acoustique : Acoustic pressure level : Schalldruckpegel : Nivel de presión acústica : Livello di pressione acustica : Nivel de pressão acústica : Niveau akoestische druk : ΣΤΑΘΜΗ ΗΧΗΤΙΚΗΣ ΠΙΕΣΗΣ: Poziom mocy akustycznej : Käytä kuulosuojaimia: Ljudtrycksnivå : Lydtryk : Nivel presiune acustică :	Уровень акустического давления : Akustik basınç seviyesi : Hladina akustického tlaku : Hladina akustického tlaku : Lydtrykknivå: مستوى الضغط السمعي. A hangnyomás szintje : Nivo akustičnega pritiska: Равнище на акустично налягане : Helirõhu nivoo Akustinio spaudimo lygis Akustiskā spiediena līmenis Razina zvučnog tlaka:	93 dB (A)

 L_{WA}	Niveau de puissance acoustique : Acoustic power level : Schalleistungspegel : Nivel de potencia acústica : Livello di potenza acustica: Nivel de potência acústica: Niveau akoestische vermogen : ΕΠΙΠΕΔΟ ΙΣΧΥΟΣ ΉΧΟΥ: Poziom mocy akustycznej : Käytä suojalaseja : Ljudstyrkenivå : Lydstyrke : Nivel putere acustică :	уровень мощности звука : Akustik basınç seviyesi : Hladina zvukového výkonu: Hladina zvukového výkonu: Lydeffektivnivå: مستوى الخرجي. a hangnyomás szintje : Nivo akustične jakosti : Равнище на вибрации : Helivõimsuse nivoo Triukšmo lygis Akustiskās jaudas līmenis Razina zvučne snage:	106 dB (A)

NIVEAU SONORE D'ÉMISSION :

A VIDE

Pression acoustique LpA poste opérateur
Incertitude

93 dB
3

Puissance acoustique LWA
Incertitude

106 dB
3

Valeurs déterminées suivant le code d'essai de l'annexe B de la norme EN 61029-1 avec emploi des normes de base ISO 11201 et ISO 3744.

Les niveaux de pression acoustique obtenus in situ dépendent:

- Des niveaux réels de la machine considérées, en prenant en compte les incertitudes déclarées;
- Du local et de l'installation de la machine. Préférez une pièce dont l'acoustique est plus feutrée. Evitez les pièces vides à grande résonance. Placez vous auprès d'une fenêtre le cas échéant.
- Des outils montés, des pièces travaillées, des réglages choisis,...

 L_{WA}	Niveau de vibration : Hand/arm vibration level : Vibrationspegel Hand/Arm : Nivel de vibración mano/brazo : Livello di vibrazione mano/braccio : Nivel de vibração mão/braço : Trillingsniveau hand/arm : ΕΠΙΠΕΔΟ ΚΡΑΔΑΣΜΩΝ: Poziom wibracji rózka/ramię : Tärinätaso: Vibrationsnivå hand/arm : Vibrationsniveau : Nivel vibrații :	Уровень вибрации : Titreşim seviyesi : Úroveň vibrací : Hladina vibrácií : Vibrasjonsnivå: مستوى الارتجاج. Vibrációsztint : Nivo vibracij : Равнище : Vibrācijas līmenis. Vibrācijas lygis Vibratsiooni nivo Razina vibracije:	2,2 m / s ²

VIBRATIONS:

Total des valeurs de vibration (somme vectorielle des trois directions) déterminée selon EN 60745 :

a 2,2 m/s²
Incertitude K 1,5 m/s²

L'amplitude d'oscillation peut être utilisée comme valeur de comparaison d'outils électroportatifs.
Attention : si l'outil électroportatif est utilisé pour d'autres applications, avec d'autres outils de travail, l'amplitude d'oscillation peut être différente.





	<p>Porter des lunettes de sécurité : Wear protective eyewear : Schutzbrille tragen : Llevar puestas gafas protectoras : Portare de gli occhiali di sicurezza : Utilizar óculos de segurança : Draag een veiligheidsbril : ΦΟΡΑΤΕ ΠΡΟΣΤΑΤΕΥΤΙΚΑ ΓΥΑΛΙΑ: Zakładać okulary ochronne : Käytä suojalaseja : Använd skyddsglasögon : Der skal benyttes sikkerhedsbriller : Purtati ochelari de protectie :</p>	<p>Наденьте защитные очки : Güvenlik gözlükleri takın : Používejte bezpečnostní brýle : Noste ochranné okuliare : Bruk vernebriller: حَمَلْ نظارات وقاية. Viseljen védőszemüveget : Nositi zaščitna očala : Да се използват защитни очила : Kandke kaitseprille Nešioti apsauginius akinius Valkät aizsargbrilles Nositi zaštitne naočale:</p>	×
---	--	--	---

	<p>Porter un masque anti-poussière : Wear a dust mask : Staubschutzmaske tragen : Llevar puesta una careta de protección contra el polvo : Indossare una mascherina anti-polvere : Utilizar uma máscara anti-poeira : Draag een stofmasker : ΦΟΡΕΣΤΕ ΜΑΣΚΑ ΓΙΑ ΤΗ ΣΚΟΝΗ: Zakładać maskę przeciwpylową Käytä pölysuojust : Bär mask mot damm : Der skal benyttes beskyttelsesmaske mod støv: Purtati mască anti-praf :</p>	<p>Наденьте респиратор : Toza karşı maske takın : Používejte masku proti prachu : Noste ochrannú masku proti prachu : Bruk en støvmaske: لبس قناع جوارح للغبار. Viseljen porvédő maszkot Nositi zaščitno masko proti prahu: Да се използва защитна маска : Kandke tolmumaski. Dėvėti respiratorių Valkät aizsarg masku pret puteklēm Nositi masku za zaštitu od prašine:</p>	×
---	---	--	---

	<p>Porter une protection auditive : Wear hearing protective equipment: Gehörschutz tragen: Llevar puesta una protección auditiva: Portare una protezione uditiva: Utilizar uma protecção auditiva: Draag gehoorbeschermers: ΦΟΡΑΤΕ ΠΡΟΣΤΑΣΙΑ ΑΚΟΗΣ: Zakładać słuchawki ochronne Käytä kuulosuojaimia: Bär hörselskydd: Der skal benyttes høreværn: Purtati căști de protecție auz:</p>	<p>наденьте средства звуковой защиты: İşitsel koruma aleti takın: Používejte ochranu sluchu: Noste ochranné slúchadlá: Bruk hørselsvern: لبس خوذة خضض الخس حجي Viseljen fülvédőt Nositi zašito ušes: Да се използва слухови защитни средства: Kandke kõrvakaitset Nešioti apsaugā nuo triukšmo Valkät dzirdes aizsarglīdzekļi Nositi štitnike protiv buke:</p>	×
---	--	--	---

	<p>Porter des gants : Use rubber gloves : Schutzhandschuhe tragen : Llevar guantes de protección : Indossare i guanti di protezione : Utilizar luvas de protecção : Draag veiligheidshandschoenen : ΦΟΡΩΝΤΑΣ ΓΑΝΤΙΑ: Używać rękawic ochronnych : Käytä suojakäsineitä : Använd skyddshandskar : Der skal benyttes handsker : Purtati mănuși :</p>	<p>Наденьте перчатки : Eldiven takın : Noste rukavice : Noste rukavice : Bruk hansker: لبس قفازات. Viseljen kesztyű t Nositi rokavice: а се използват предпазни ръкавици : Kandke kindaid Mūvēti pirštines Valkät cimdus Nositi zaštitne rukavice:</p>	×
---	---	--	---





	<p>Soumis à recyclage Subjected to recycling Sujeto a reciclaje Sottoposti a riciclaggio Sujeitos à reciclagem Não deite no lixo : Niet wegwerpen : ΥΠΟΚΕΙΤΑΙ ΣΕ ΑΝΑΚΥΚΛΩΣΗ Nie wyrzucac : Älä heitä pois luontoon : Batteriet får inte kastas : Bortkast det ikke: Nu le auncati :</p>	<p>Подлежит переработке Atmayıniz : Nevyhazujte je do běžného odpadu : Neodhadzovat : Gjenvinningspliktig فلا ترمدها هنا في القمامة. ne mečite1 Ne odvržite ga/jih vstran : Taaskasutusse kuuluv Ärge visake seda minema : Nemétykite : Nemest : Podvrgnuto recikliranju</p>	×
---	---	--	---

Recyclage des déchets :

Les outils, accessoires et leur emballages doivent suivre une voie de recyclage adaptée. Conformément aux directives Européenne 2012/19/UE et 2006/66/CE, les composants d'un produit doivent être séparés, collectés, recyclés ou éliminés en conformité avec les réglementations environnementales en vigueur. Les appareils, batteries, piles, huiles, emballages devront être déposés dans les systèmes d'élimination des déchets spéciaux tels que déchetteries. Renseignez-vous auprès de votre commune pour connaître l'organisme le plus proche à même de retraiter ou de collecter ces déchets.

	<p>Recyclable, soumis au tri sélectif Recyclable, subject to recycling Recyclingfähige, unterliegen Recycling Reciclables, sujetos a reciclaje Riciclabili, soggetti a riciclaggio Recicláveis, sujeito à reciclagem Recycleerbare, onderworpen aan recycling ΑΝΑΚΥΚΛΩΣΙΜΟ, ΥΠΟΚΕΙΤΑΙ ΣΕ ΕΠΙΛΕΚΤΙΚΗ ΔΙΑΛΟΓΗ Opakowanie nadaje się do recyklingu podlegają recyklingu Kierrätettävien pakkausten kohteena kierrätys Återvinningsbara förpackningar omfattas återvinning Рециклираци се опаковки подлежат на рециклиране Genanvendelig underlagt genbrug</p>	<p>Reciclabile sub rezerva reciclare Повторно упаковка подлежит вторичной переработке Geri dönüŝüm Geri dönüŝtürülebilir ambalaj konusu Recyklovateľné podléhající recyklaci Recyklovateľné podliehajúce recyklácii Resirkulerbar, med forbehold om selektiv sortering ريودتلا ها عال يخرىت ريودتلا ها عال قباؤلا فحل غل او قىب غل Újrahasznosítható csomagolás alá újrahasznosítás Reciklirati predmet recikliranja Pakendite suhtes ringlussevõtu Pārstrādājams iepakojumš otrreizējai pārstrādei Perdirbamų taikomos perdirbimo Može se reciklirati, podložno selektivnom sortiranju</p>	×
---	--	---	---





REX 60

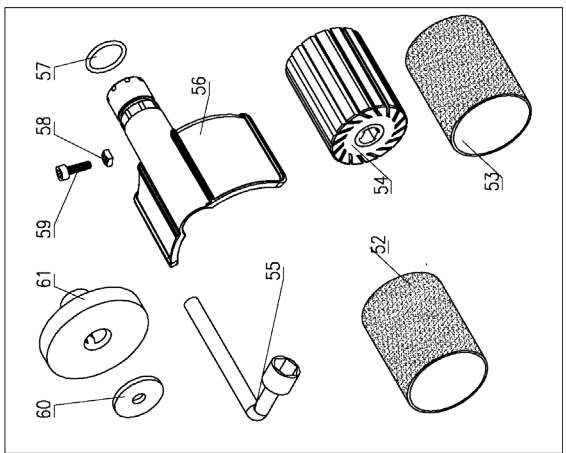
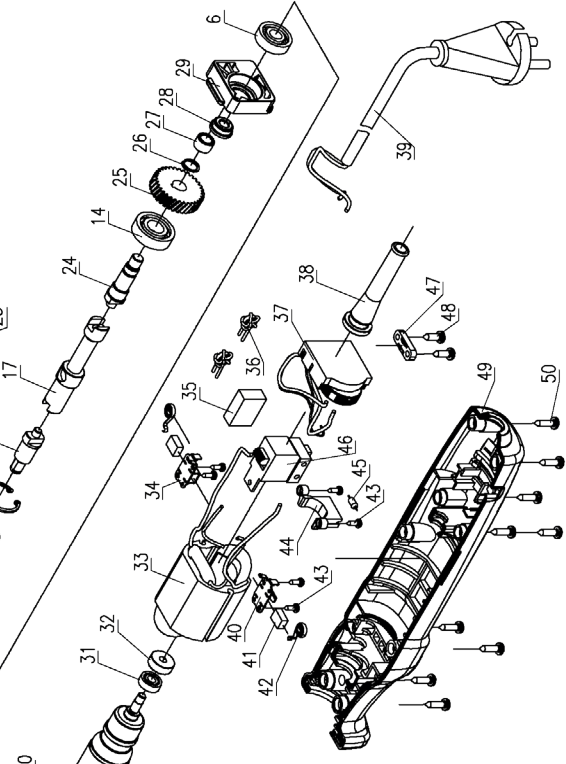
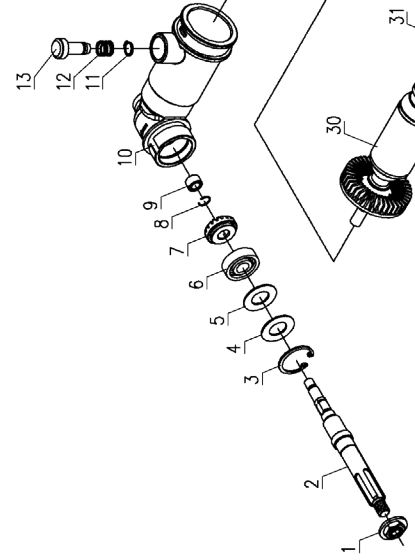
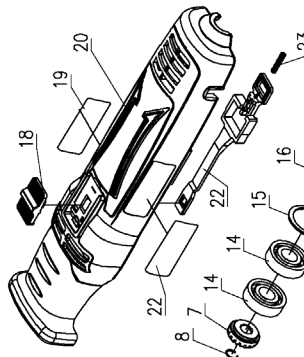
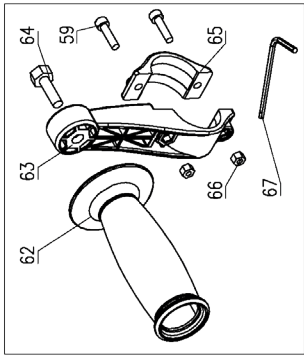

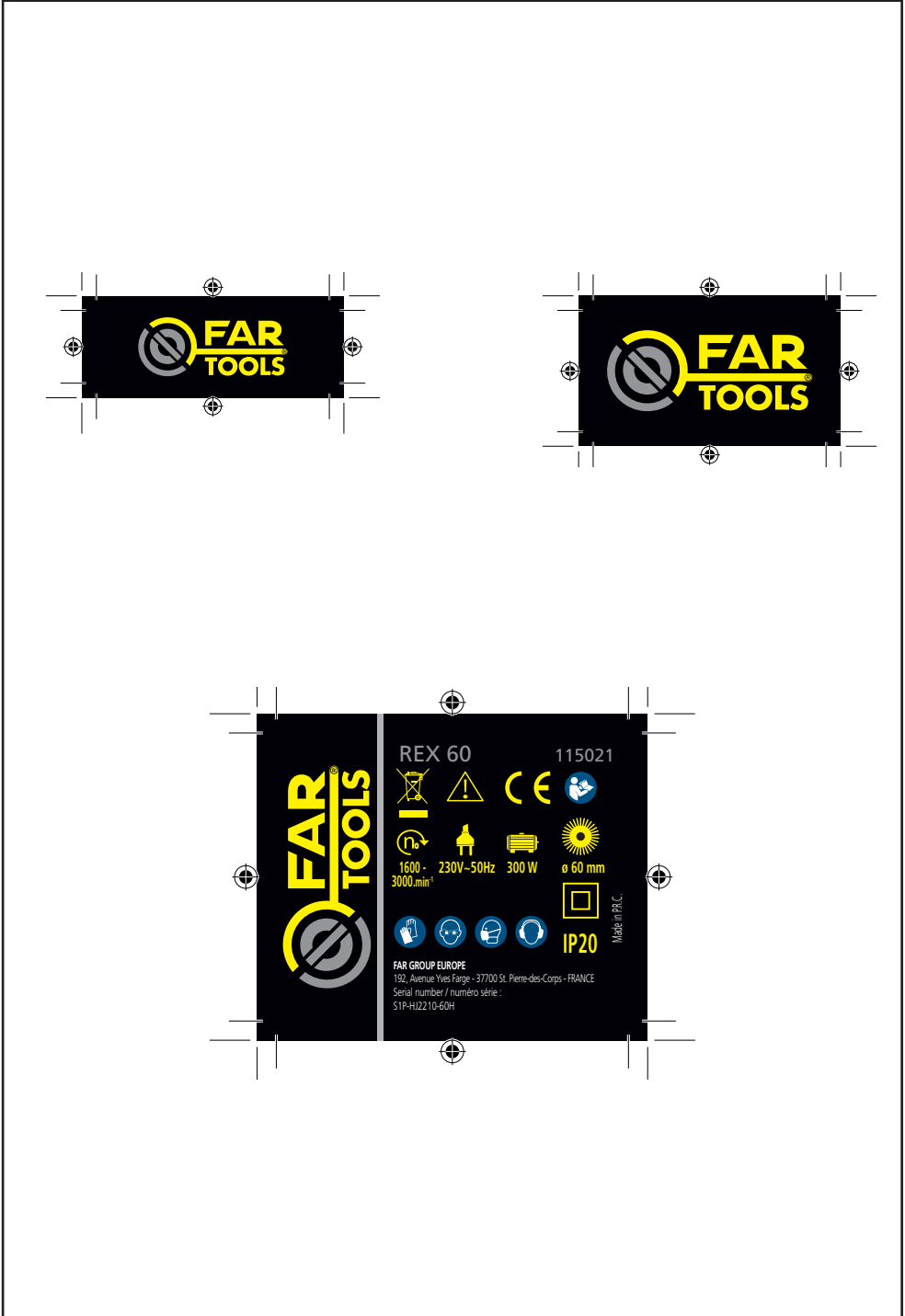



DECLARATION DE CONFORMITE
 VERKLARING VAN OVEREENSTEMMING
 DECLARACION DE CONFORMIDAD
 DICHIARAZIONE DI CONFORMITA
 KONFORMITÄSERKLÄRUNG
 DECLARATION CONFORMITY
 DECLARAÇÃO DE CONFORMIDADE
 DEKLARACJA ZGODNOSCI Z NORMAMI
 OM ÖVERENSSTÄMMELSE
 VAATIMUSTENMUKAISUUSVAKUUTUS
 OVERENSSTEMMELSESERKLÆRING
 ΔΗΛΩΣΗ ΣΥΜΜΟΡΦΩΣΗΣ

DECLARAȚIE DE CONFORMITATE
 VYHLÁSENIE ZHODY
 Декларация соответствия
SAMSVARSERKLÆRING
 Uygunluk beyanı
 التصريح بالخطابفة
 PROHLÁŠENÍ SHODY
 EGYZSÉGI NYILATKOZAT
 Декларация за съответствие с нормите
 IZJAVA O SKLADNOSTI
 DEKLARACIJA
 ATITIKTIES DEKLARACIJA
 KINNITUS
 IZJAVA O SUKLADNOSTI

Le soussigné,
 Ondergetekende,
 Der Unterzeichner,
 O abaixo assinado,
 Undertecknad,
 Долуподписаният
 Undertegnede
 Subsemnatul,
 Я, нижеподписавшийся,
 Imzalayan,
 Níže podepsany,
 Toliau pasirašęs

Personne autorisée à constituer
 le dossier technique :
 Christophe HUREL



FAR GROUP EUROPE
 192, Avenue Yves Farge
 37700 St. Pierre-des-Corps
 FRANCE

El suscrito,
 Il sottoscritto,
 The undersigned,
 Níže podpísany
 Allkirjoittanut,
 Ο ΚΑΤΩΘΙ ΥΠΟΓΡΑΦΜΕΝΟΣ,
 Níže podpísany
 Undertegnede,
 الجوق ع ادناه
 Alulirott,
 Podpisani,
 Apakšā parakstījis
 allakirjutanu
 Dolje potpisani,

Declara por la presente, que,
 Dichiare che,
 Declares that,
 OÖwiadcza niniejszym, że
 Ilmoittetaan täten että,
 ΔΙΑ ΤΟΥ ΠΑΡΟΝΤΟΣ ΔΗΛΩΝΕΙ ΟΤΙ,
 týmto vyhlásuje, že
 Erklærer herved at,
 کیصیح استنادا علی ذلک
 kijelentem, hogy a készülék Izjavlja da,
 Pareiskia, kad,
 Ar šo apliecinā, ka,
 Kinnitab, et
 Izjavljuje u ovom dokumentu da je

Déclare par la présente que,
 Verklaart hiermede dat,
 Erklärt hiermit daß,
 Declara pela presente que,
 Förklarar härmed att
 Заявляя с настоящото
 erklærer hermed, at
 Declar prin prezenta că,
 настоящим подтверждаю, что
 Mevcut belgeye beyan ediliyor ki,
 tímto prohlašuje, že,
 Pareiskia, kad,

Renovateur de précision / Accuracy renovator / Renovator Genauigkeit / Exactitud renovador / Precisione Renovator / Exatidão Renovador /
 Nauwkeurigheid Renovator / ΑΚΡΙΒΕΙΑ ΑΝΑΚΑΙΝΙΣΤΗΣ / Dokładność Odnowiciel / Renovator tarkkuus / Renovator noggrannhet / Точност обновитель /
 Renovator nøjagtighed / Precizie renovator / Точность Реноватор / Renovator doğruluğu / Presnost renovator / Presnost renovator / Renovator pontosság /
 Natančnost Obnovilac / קריבנות קיד / كرمقو قود / ح لرمقو قود / Renoveerija täpsus / Atjaunotājs precizitāte / Preciznost osvjježavač

code

FARTOOLS / 115021 / REX 60 / S1P-HJ2210-60H

Est conforme et satisfait aux directives et normes CE,
 In overeenstemming is met en Voldoet aan EG richtlijnen,
 Den folgenden EU-Bestimmungen entspricht,
 Respeita e está em conformidade com as normas CE,
 Överensstämmer med och uppfyller EG-standarder,
 Съответства и отговаря европейските норми
 Er i overensstemmelse med og overholder EU standarderne
 Este conform și satisfacă normele CE
 полностью соответствует и удовлетворяет
 требованиям стандартов ЕС
 CE şartlara uygundur,
 odpovídá normám ES.
 Atitinka ir atitinka EB direktyvas ir standartus,

Cumple con la directivas de la CE,
 E conforme alle direttive CEE,
 Complies with the EEC directives and standards,
 Odpowiada normom UE,
 Täyttää EU-vaatimukset,
 ΣΥΜΜΟΡΦΩΝΕΤΑΙ ΚΑΙ ΙΚΑΝΟΠΟΙΕΙ ΤΙΣ ΟΔΗΓΙΕΣ ΚΑΙ ΤΑ ΠΡΟΤΥΠΑ CE,
 zodpovedá normám ES.
 Samsvarer med og tilfredsstiller CE-direktiver og standarder,
 بان الجهاز يطابق و يلبى معايير مجموعة الدول الأوروبية
 Kielegiti a CE szabványok előírásait.
 Je v skladu z in izpolnjuje norme Evropske skupnosti.
 Atbilst un atbilst EK direktivas un standartus,
 Vastab ja vastab EU direktīvidele ja standartidele,
 Sukladan i ispunjava direktive i standarde CE,

2006/42/EC, 2014/30/EU, 2011/65/EU 2015/863/EU

EN 62841-2-4=2014+AC=2015
 EN 62841-1=2015+AC=2015+A11=2022
 EN IEC 55014-1:2021
 EN IEC 55014-2:2021
 EN IEC 61000-3-2:2019+A1:2021
 EN 61000-3-3:2013+A1:2019+A2:2021

Christophe HUREL,
 Président Directeur Général
 11/02/2025
 Fait à St. Pierre-des-Corps



GARANTIE - WARRANTY



FR. GARANTIE

Cet outil est garanti contractuellement contre tout vice de construction et de matière, à compter de la date de vente à l'utilisateur et sur simple présentation du ticket de caisse. La garantie consiste à remplacer les parties défectueuses. Cette garantie n'est pas applicable en cas d'exploitation non conforme aux normes de l'appareil, ni en cas de dommages causés par des interventions non autorisées ou par négligence de la part de l'acheteur. La garantie ne s'applique pas sur les dommages causés par une défectuosité de l'outil.

DE. GARANTIE

Die Garantiezeit für dieses Gerät in Bezug auf Konstruktions- und Materialfehler beträgt lt. Vertrag bei Vorlage des Kassensbons. Die Garantieleistung besteht im Ersatz schadhafter Teile. Die Garantie erlischt bei einem Einsatz des Geräts, der nicht normentsprechend ist, bei Schäden, die auf unsachgemäße Eingriffe zurückzuführen sind bzw. bei Nachlässigkeit seitens des Käufers. Die Garantie erstreckt sich nicht auf Schäden, die auf Fehlfunktionen des Geräts zurückzuführen sind.

IT. GARANZIA

Questo attrezzo è garantito per contratto contro qualsiasi difetto di costruzione e di materia, a partire dalla data di vendita all'utente e su semplice presentazione dello scontrino. La garanzia consiste nel sostituire le parti difettose. Questa garanzia non è applicabile in caso di sfruttamento non conforme alle norme dell'apparecchio, né in caso di danni causati da interventi non autorizzati o da negligenza da parte dell'acquirente. La garanzia non si applica ai danni causati da un avaria dell'attrezzo.

EN. GARANTIE

This tool is guaranteed, in writing, against any defect in manufacture of parts from the date of sale, upon simple presentation of the sales slip. The guarantee is limited to the replacement of faulty parts. This guarantee is not applicable in the event of usage which is not conform with the intended usage of the apparatus, nor in the event of damage caused by unauthorised servicing or negligence on behalf of the purchaser. This guarantee does not apply to any damage caused by the failure of this tool.

ES. GARANTIA

Esta herramienta se garantiza contractualmente contra todo defecto de construcción y materia, a partir

de la fecha de venta a l'usuariu y sobre simple presentación del recibo de caja. La garantía consiste en sustituir a las partes defectuosas. Esta garantía no es aplicable en caso de explotación no conforme a las normas del aparato, ni en caso de daños causados por intervenciones no autorizadas o por negligencia por parte del comprador. La garantía no se aplica sobre los daños causados por un fallo del herramienta.

NL. GARANTIE

Dit gereedschap heeft een garantie tegen constructiefouten en materiaaldefecten, die geldig is vanaf de aankoopdatum door de gebruiker, op vertoning van de kassabon. De garantie betreft de vervanging van de defecte onderdelen. Deze garantie is niet van toepassing indien het apparaat niet volgens de normen gebruikt is, noch in geval van schade veroorzaakt door onbegrijpelijk gebruik of nalatigheid van de koper. De garantie is niet van toepassing op schade voortvloeiend uit een defect van het gereedschap.

PT. GARANTIA

Esta ferramenta tem uma garantia contratual contra qualquer defeito de construção e de material, a partir da data de venda ao utilizador e sobre simples apresentação do talão da caixa. A garantia consiste em substituir as partes defeituosas. Esta garantia não é aplicável no caso de exploração não conforme as normas do aparelho, nem em caso de danos causados pelas intervenções não autorizadas ou por negligência da parte do comprador. A garantia não se aplica para os danos causados por uma falha da ferramenta.

EL. ΕΓΓΥΗΣΗ

ΑΥΤΟ ΤΟ ΕΡΓΑΛΕΙΟ ΕΙΝΑΙ ΣΥΜΒΑΤΙΚΑ ΕΓΓΥΗΜΕΝΟ ΓΙΑ ΟΠΟΙΟΔΗΠΟΤΕ ΚΑΤΑΣΚΕΥΑΣΤΙΚΟ ΚΑΙ ΥΛΙΚΟ ΕΛΑΤΤΩΜΑ, ΑΠΟ ΤΗΝ ΗΜΕΡΟΜΗΝΙΑ ΠΩΛΗΣΗΣ ΣΤΟΝ ΧΡΗΣΤΗ ΚΑΙ ΜΕ ΤΗΝ ΕΠΙΔΕΙΞΗ ΤΗΣ ΑΠΟΔΕΙΞΗΣ ΠΩΛΗΣΗΣ. Η ΕΓΓΥΗΣΗ ΣΥΝΙΣΤΑΤΑΙ ΣΤΗΝ ΑΝΤΙΚΑΤΑΣΤΑΣΗ ΤΩΝ ΕΛΑΤΤΩΜΑΤΙΚΩΝ ΕΞΑΡΤΗΜΑΤΩΝ. ΑΥΤΗ Η ΕΓΓΥΗΣΗ ΔΕΝ ΙΣΧΥΕΙ ΣΕ ΠΕΡΙΠΤΩΣΗ ΛΕΙΤΟΥΡΓΙΑΣ ΠΟΥ ΔΕΝ ΣΥΜΜΟΡΦΩΝΕΤΑΙ ΜΕ ΤΑ ΠΡΟΤΥΠΑ ΤΗΣ ΣΥΣΚΕΥΗΣ, ΟΥΤΕ ΣΕ ΠΕΡΙΠΤΩΣΗ ΖΗΜΙΑΣ ΠΟΥ ΠΡΟΚΑΛΕΙΤΑΙ ΑΠΟ ΜΗ ΕΞΟΥΣΙΟΔΟΤΗΜΕΝΕΣ ΕΠΕΜΒΑΣΕΙΣ Ή ΑΜΕΛΕΙΑ ΕΚ ΜΕΡΟΥΣ ΤΟΥ ΑΓΟΡΑΣΤΗ. Η ΕΓΓΥΗΣΗ ΔΕΝ ΙΣΧΥΕΙ ΓΙΑ ΖΗΜΙΑΣ ΠΟΥ ΠΡΟΚΑΛΟΥΝΤΑΙ ΑΠΟ ΑΣΤΟΧΙΑ ΕΡΓΑΛΕΙΟΥ.

PL. GWARANCJA

Narz dzie jest objte gwarancja na wszelkie wady konstrukcyjne i materiałowe, licząc od daty sprzedaży u użytkownika i po okazaniu paragonu kasowego. Gwarancja obejmuje wymianę cz.ści wybrakowanych. Gwarancja nie znajduje zastosowania w przypadku użytkowania niezgodnego z normami urzadzenia, ani w przypadku szkód spowodowanych

działaniami niedozwolonymi lub zaniedbaniami ze strony nabywcy. Gwarancja nie obejmuje szkód powstałych z powodu upadku urzadzenia.

SV. GARANTI

Detta verktyg har en avtalsenlig garanti mot konstruktions- och materialfel, från och med tidpunkten för användarens inköp och genom uppvisning av kassavittor. Garantin består i att ersätta de bristfälliga delarna. Denna garanti gäller inte om användningen inte motsvarar apparatens standarder, inte heller vid skador som orsakas av ej tillåtna ingrepp eller på grund av koparens vårdslöshet. Garantin gäller inte forskador som orsakats av att verktyget fungerat bristfälligt.

FI. TAKUU

Tämän laiteen takuu on voimassa sopimuksenmukaisesti kattaen kaikki rakennne- ja materiaaliiviat lukien ostopaivasta kassakuittia vastaan. Takuu sisältää viallisten osien korvaamisen. Takuu ei korvaa onneiden- ystäistä käyttöä eikä vialtuuttamattomien henkilöiden kasittelystä tai ostanajan huolimattomuudesta aiheutuista vahinkoista. Takuu ei vastaa myöskään toimintahäiriöistä aiheutuista vahinkoista.

BU. Гаранция

Този инструмент е под договорна гаранция срещу всякакъв дефект в изработката и използваните материали, считано от датата на продажба на потребителя и само срещу представяне на касовата бележка. Гаранционното обслужване се състои в замяна на дефектните части. Настоящата гаранция не е валидна когато апаратът се използва по начин, несъответстващ на стандарта за работа с него, както и в случай на щети, нанесени от неоторизирани лица, или вследствие на проявена небрежност от страна потребителя.

Гаранцията не покрива щети, произтекли вследствие на техническа неизправност на апарата.

DA. GARANTI

Dette værktøj er dækket af en garantikontrakt for konstruktions- og materialefejl, som gælder fra købsdatoen ved visning af kassebonen. Garantien består i at udskifte de defekte dele. Garantien dækker ikke fejl opstået som følge af anvendelse, som ikke overholder standarderne for apparatet, eller

SERVICE APRÈS VENTE - AFTER SALE SERVICE

FARGROUP EUROPE - 192, Avenue Yves Farge - 37700 St. Pierre-des-Corps - FRANCE

fargroup@fargroup.net

GARANTIE - WARRANTY



skader opstæet ved ikke autoriserede indgreb eller søstehed fra brugerens side. Garantien dækker ikke skader opstæet, fordi værktøjet har svigtet.

RO. GARANTIE

Acest aparat este garantat din punct de vedere contractual împotriva tuturor vicilor de construcție și de material, începând de la data vânzării lui către utilizator și la simpla prezentare a bonului de casă. Garanția constă în înlocuirea componentelor defecte. Această garanție nu se aplică în cazul exploatarii în alt mod decât cel recomandat de normele aparatului și nici în caz de stricăciuni provocate de intervenții neautorizate sau prin neglijența cumpărătorului. Garanția nu se aplică asupra pagbelor cauzate de o defectare a aparatului.

RU. ГАРАНТИЯ

Данное изделие обладает прочностью, силой и надежностью, гарантией, покрывающей все возможные дефекты изготовления и материала. Гарантия вступает в силу с даты продажи изделия пользователю, для этого достаточно сохранить и предъявить полученный в кассе чек. Гарантия обязывает изготовителя заменить дефектные части изделия. В случае не соответствующего нормам использования изделия, несанкционированного демонтажа или ремонта или небрежного обращения действие гарантии прекращается. Гарантия не покрывает ущерб, возникший в результате сбоя в работе изделия.

TU. GARANTIJA

Bu, arac, satis tarihinden itibaren, kullanicinin sadece vezne alindisini sunmasiya tum uretim ve malzeme hatasina karsi garantilidir. Garanti eksik olan kisimlari degistirmek icindir. Bu garanti aracin sartlarina uygun olmayan isleme durumunda, izin verilmeyen kullanimlardan kaynaklanan hasarlarda veya kicirinin istegi durumunda uygulanmaz. Garanti malzemenin bir eksikliginden meydana gelen bir zararda uygulanmaz.

CS. ZÁRUKA

Pro tento nástroj platí smluvní záruka na všechny výrobny a materiálové vady od data prodeje uživateli a na základe predložení pokladniho bloku. Záruka spočívá ve výmene vadných castí. Táto záruka neplatí v prípade pouziti prístroje, ktoré

neodpovídá normám, ani v prípade škod spôsobených nepovolenými zásahy alebo nedbalosťou ze strany kupujúceho. Záruka se nevztahuje na škody způsobené zavádou nástroje.

SK. ZÁRUKA

Pre tento nástroj platí zmluvná záruka na všetky výrobné a materiálové chyby od dátumu predaja uživateli a na základe predloženia pokladničného bloku. Záruka spočíva vo výmene chybných castí. Táto záruka neplatí v prípade použitia prístroja, ktoré nezodpovedá normám, ani v prípade škod spôsobených nepovolenými zásahmi alebo nedbalosťou zo strany kupujúceho. Záruka sa nevztahuje na škody spôsobené poruchou nástroja

AR. الضمان

في لغتي ءارشلاقاطب ميدقت درجم بلع ءانبو لعتمسلا بلا عنبلا خيرات نم ارباعا بادوملايفوع ينصتلا يف بيع با نم ايدفاعت قئومضم مد علا هذه نا تافاللتال هضرعت ءلأحيف الو بزاهجلا زيباعمل قنابملا ربع مارختسبالا ءلأح يف قنبتلل الباق نامضلا اءة نوكي ال قنابملا ءازجالا لايبس يف نامضلا للتع عم حنانلا ررضلا بلع نامضلا قنطنى ال يرشملا لبق نم لامهالا ءلأح يف وا قنصخرم ربع لحدث تابلعم نع مكنبار

HU. GARANCIA

Erre a szerszámra szerződéses garanciát vállalunk bármilyen gyártási es anyaghibára felmerülő esetére, a fogyasztó részére történt eladás napjától számítva, a penztári blokk egyszerű felmutatása elleneben. A garancia a hibás alkatrészek cseréjére terjed ki. Ez a garancia nem érvényes, ha a készüleket nem rendeltetésszerűen használták, sem illetéktelen beavatkozások vagy a vásárló hanyagsága okozta károk esetén. A garancia nem fedezi azokat a károkat melyeket a szerszám hibás működése okozott.

SI. GARANCIJA

To orodje je z garancijsko pogodbo zasciteno proti vsem napakam v izdelavi in v sestavnem materialu od datuma prodaje naprej in ta velja ob predložitvi blagajniškega računa. Garancija velja za zamenjavo delov z napako. Ta garancija ne velja za uporabo orodja, ki ni v skladu z normami, predpisanimi za omenjeno orodje in za primere okvar, ki nastanejo zaradi nedovoljenih posegov na orodju ali zaradi malomarnega rokovanja kupca. Garancija ne velja za škodo, ki jo lahko povzroci okvara orodja.

ET. GARANTII

See toorist kuulub lepingu järgi garantiiremonti arvestades alates muumise päevast ja kassatseki alusel kasutajale koigi konstruktsiooni- ja materjalivigade puhul. Garantii seisneb defektsete osade välja-

vahetamises. See garantii ei kehti aparaadi normide ebatavalise eiramise puhul ega ostja poolt keelatud viisil, kasutamises või hooletussejätmisest tulenevate kahjude korral. Garantii ei kehti seadme defektidest põhjustatud kahjude puhul

LV. GARANTĪJA

Šis prietaiss yra iztikrinamas kaip itin geros kokybes, nuo jo pardavimo datos iki jo panaudojimo, ir jam yra suteikiama garantinis talonas. Garantijos metu galima pakeisti atsiradusius trumplataikius gedimus. Ši garantija netaikoma esant netinkamam naudojimui ar nesilaikant reikiam šio aparato vartojimo instrukcijai, tai pat paciam pirkejiui, jį sugadinus. Garantija taip pat netaikoma, prietaisa naudojant ne pagal paskirtį ir jį apgadinus

LT. GARANTIJA

Šim darbarnkam, ir liguma noteikta garantija visiem defektiem, kas saistās ar konstrukciju un materialu, sākot ar pardosanas datumu, kad masinu pardod lietotajam un vienkarsi uzradot kases ceku. Garantija iekļauj bojato dalu nomainu. Ši garantija nav derīga, ja aparāts nav lietots saskaņā ar drošības noteikumiem, ne gadījumos ja bojājumi radusies nesankcionētās ielauktās gadijumā vai arī pierceja nolaidības dēļ. Garantija nav derīga, ja bojājumi radusies darbarnika defekta dēļ

HR. JAMSTVO

Ovaj alat ima ugovorno jamstvo u slučaju bilo kakvih nedostataka u konstrukciji i materijalu, od datuma prodaje korisniku uz jednostavno predocenje racuna. Jamstvo se sastoji u zamjeni neispravnih dijelova. Ovo se jamstvo ne primjenjuje u slučaju uporabe i eksploatacije koja nije sukladna standardima ufedaja, niti u slučaju stete uzrokovane neovlaštenim intervencijama ili nemarom kupca. Jamstvo se ne primjenjuje na štetu uzrokovanu nekim nedostatkom alata.

SERVICE APRÈS VENTE - AFTER SALE SERVICE

FARGROUP EUROPE - 192, Avenue Yves Farge - 37700 St. Pierre-des-Corps - FRANCE
fargroup@fargroup.net



FAR GROUP EUROPE

Une société du groupe **SIGMA**

192, Avenue Yves Farge
37700 St. Pierre-des-Corps
FRANCE

fartools.com

