

VEVOR

Affordable. Reliable. Home Improvement.

PLANT STANDS

(WITH LED GROW LIGHT: ZWLDT-02)



USER MANUAL

MODEL: SSPS-03-US \ SSPS-03-EU

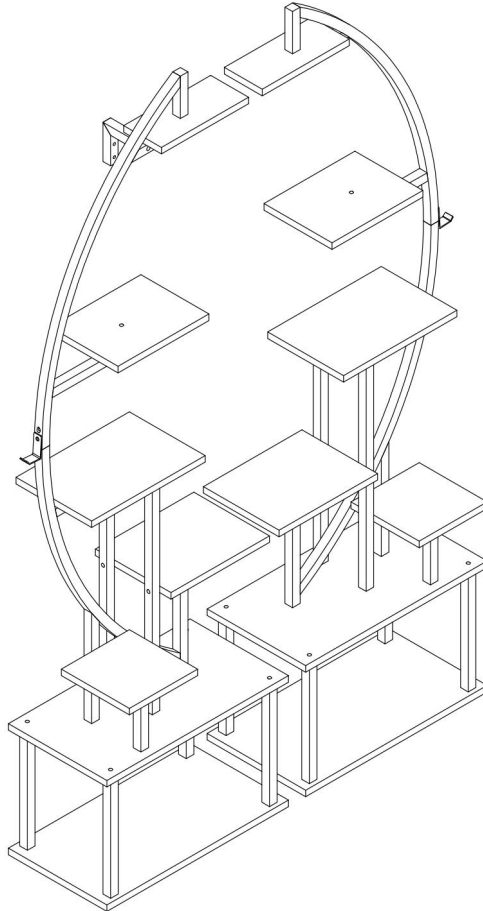
MODEL: SSPS-03-US \ SSPS-03-EU



This is the original instruction, please read all manual instructions carefully before operating. VEVOR reserves a clear interpretation of our user manual. The appearance of the product shall be subject to the product you received. Please forgive us that we won't inform you again if there are any technology or software updates on our product.

	<p>Warning-To reduce the risk of injury, user must read instructions manual carefully.</p> <p>READ ALL INSTRUCTIONS BEFORE USE</p> <p>All the safety and operating instructions should be read, adhered to and followed before the unit is operated.</p>
	<p>This device complies with Part 15 of the FCC Rules. Operation is subject to the following two conditions:(1) This device may not cause harmful interference, and (2) this device must accept any interference received, including interference that may cause undesired operation.</p>

SAFETY INSTRUCTIONS

Thank you for purchasing our Plant Stands.

- Before using the product, we kindly ask you to carefully read and follow the instructions provided below. By installing or using the product, you acknowledge that you have carefully read and accepted the following safety instructions.
- Please make sure to keep this manual for future reference.

Important Notes:

- (1) The grow light is for indoor use only.
- (2) The grow light is not waterproof, do not let the grow light soak in water.
- (3) Please disconnect the power when it thunders.
- (4) Please ensure that the product is used in normal environment. The working environment of the lamp should be lower than +104°F and 80%RH.

Safety Guidelines:

- Violation of the following instructions may lead to abnormal use of the product or unexpected losses. We strongly advise you to strictly adhere to the following guidelines.
- Install and use the product strictly in accordance with the provided instructions.

PRODUCT DESCRIPTION

- Led grow light is an excellent option for growing plants. Compared with the traditional grow light.
- Grow light has higher PPFD, lower power consumption and longer lifespan.





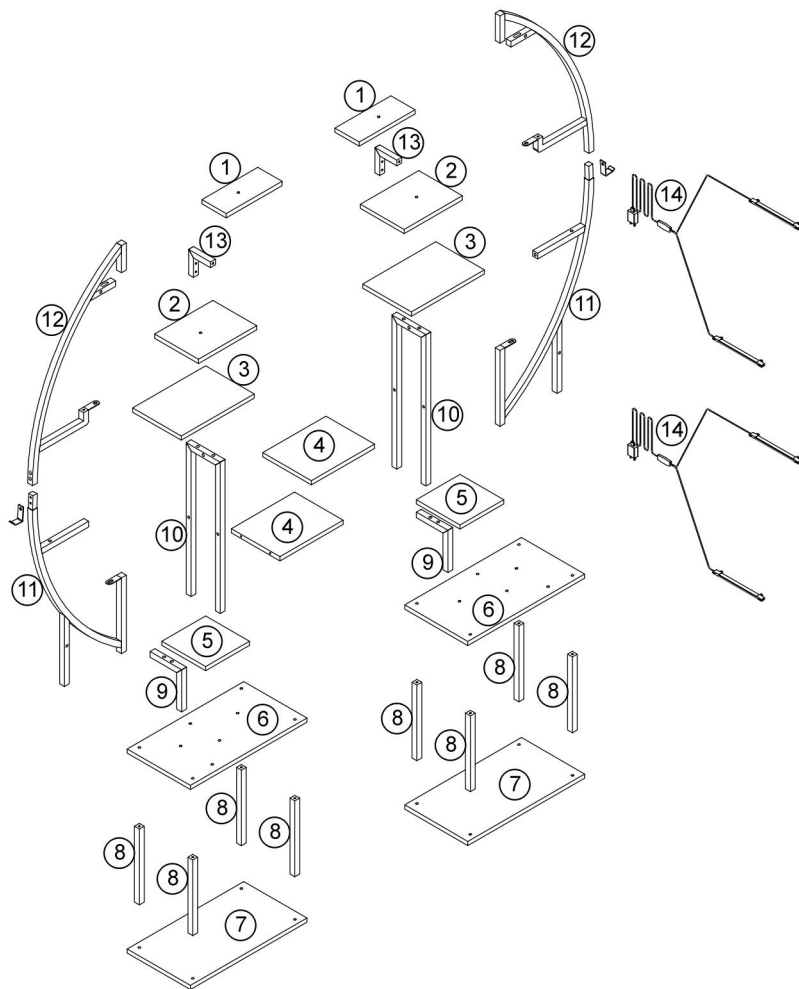

Model	SSPS-03-US	SSPS-03-EU
LED GROW LIGHT	ZWLDT-02	
District	North America	Europe
Adapter Voltage	AC 110V~120V 60Hz	AC 220V~240V 50Hz
Light Power	5~6W (Full Spectrum) / 2 Lights	
Shelf Levels	7 Levels	
Color	Brown & Black	
Material	Metals & Particle board	

PARTS LIST

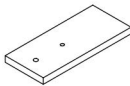
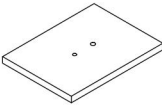
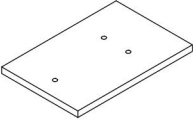
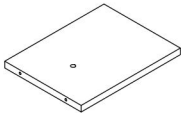
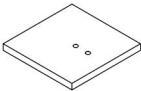
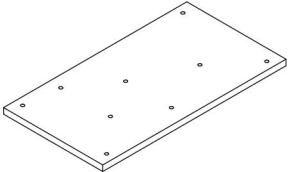
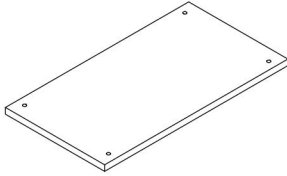

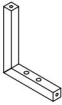
No.	PICTURE	SIZE	QTY	No.	PICTURE	SIZE	QTY
A		M6*10	8	G		S	2
B		M6*30	12	H			2
C		M6*35	18	I		ST5*40	4
D		M6*30	18				
E		ST7*40	4				
F		40*40*5	8				1

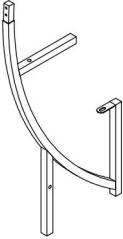
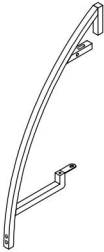
PARTS LIST

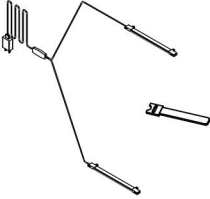
<p>1</p>  <p>X2</p>	<p>2</p>  <p>X2</p>	<p>3</p>  <p>X2</p>
<p>4</p>  <p>X2</p>	<p>5</p>  <p>X2</p>	<p>6</p>  <p>X2</p>
<p>7</p>  <p>X2</p>	<p>8</p>  <p>X8</p>	<p>9</p>  <p>X2</p>
<p>10</p>  <p>X2</p>	<p>11</p>  <p>X2</p>	<p>12</p>  <p>X2</p>
<p>13</p>  <p>X2</p>	<p>14</p>  <p>X2</p>	

ASSEMBLY INSTRUCTION

Matters needing attention

(1) When installing the screws in the installation step, the screws do not need to be tightened.

then tighten all the screws.

After this installation step is confirmed and the holes are aligned,

(2) If the screws are tightened during the installation process, it will cause problems such as misalignment of the screw holes and misalignment of the board in subsequent installations.

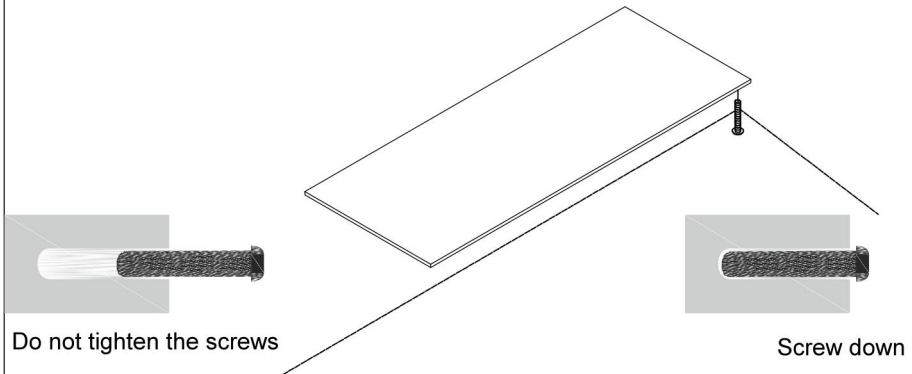

If you encounter any problems during the installation or use you can contact us at any time, we will resolve your issue within 24 hours

ASSEMBLY INSTRUCTION

STEP 1

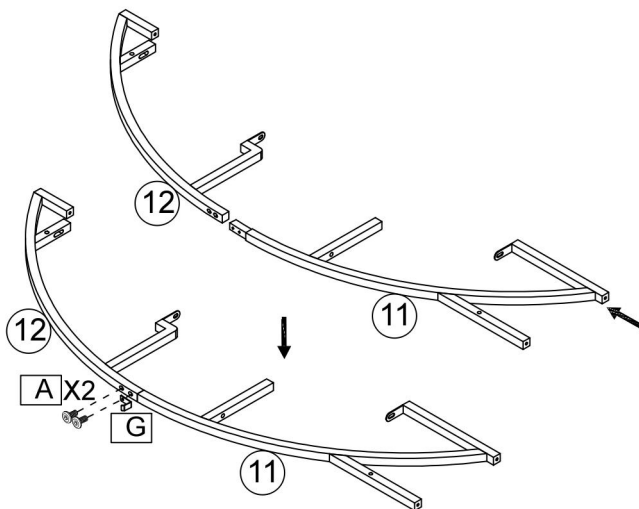

X2

A M6*10mm  X4	G  X2
--	--

STEP 2

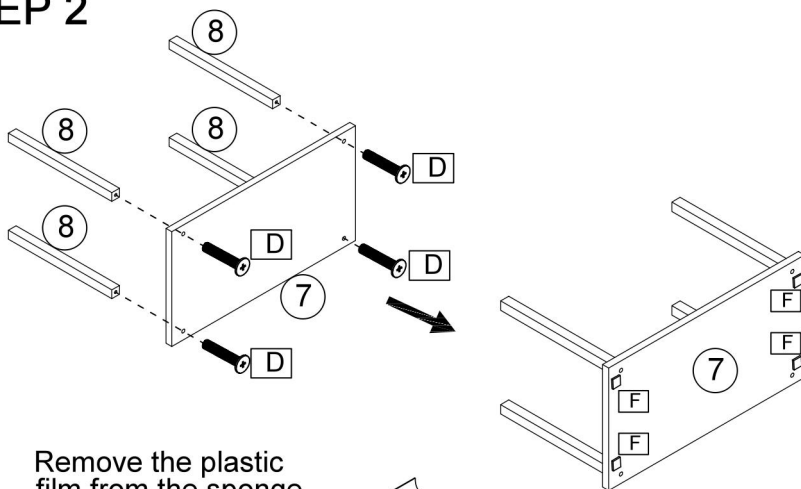

Remove the plastic film from the sponge pad before installation

X2

D M6*30mm  X8	F 40*40*5mm  X8
--	--

ASSEMBLY INSTRUCTION

STEP 3

Please note that the left and right wooden boards can be interchanged, just flip the 6th board over.

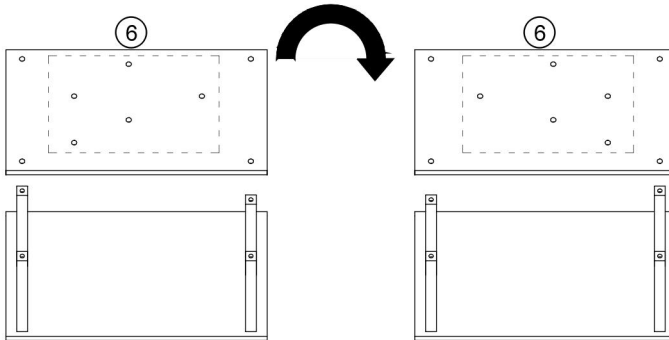

Note the direction of the hole in Board No. 6. The Hole in the left picture represents the left side, and the hole in the right picture represents the right side when the board No. 6 is reversed.

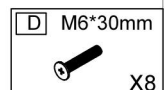
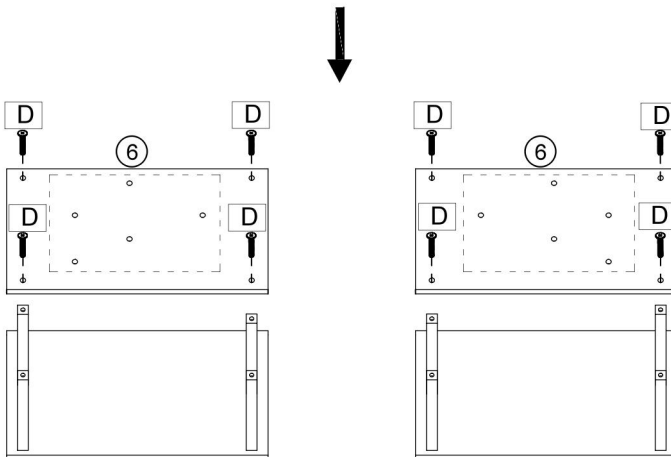

ASSEMBLY INSTRUCTION

STEP 4

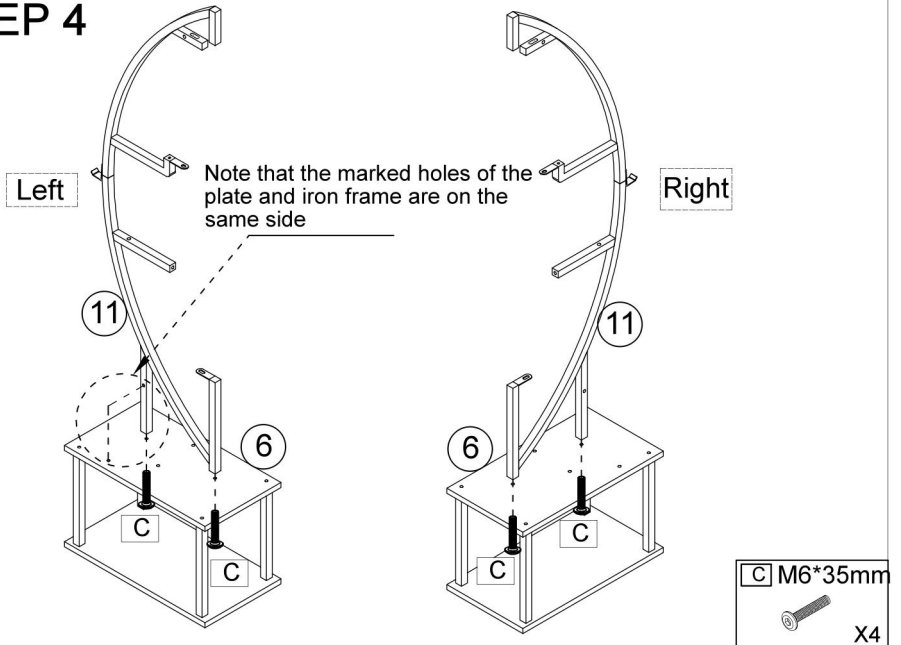

STEP 5

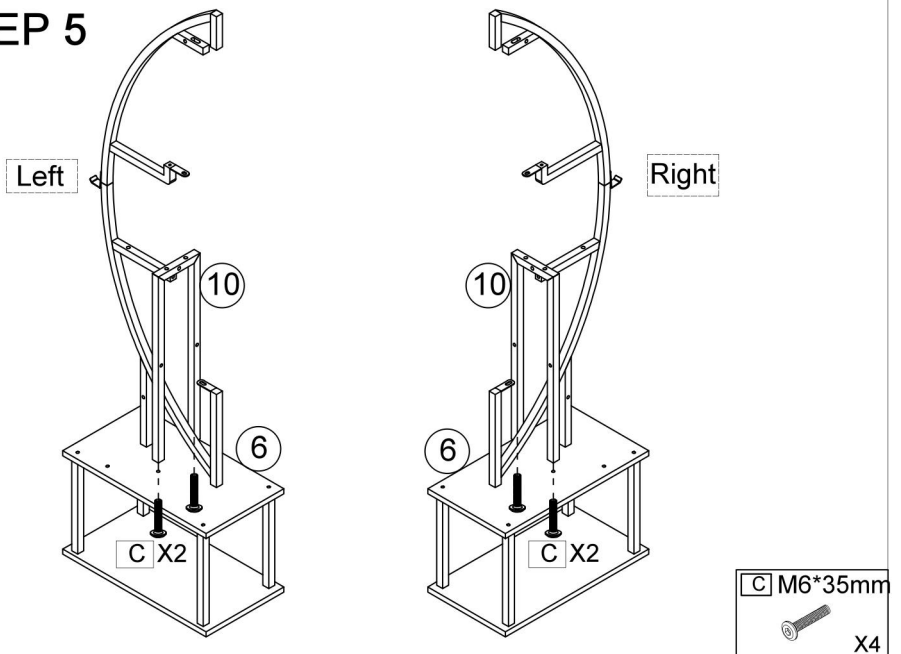

ASSEMBLY INSTRUCTION

STEP 6

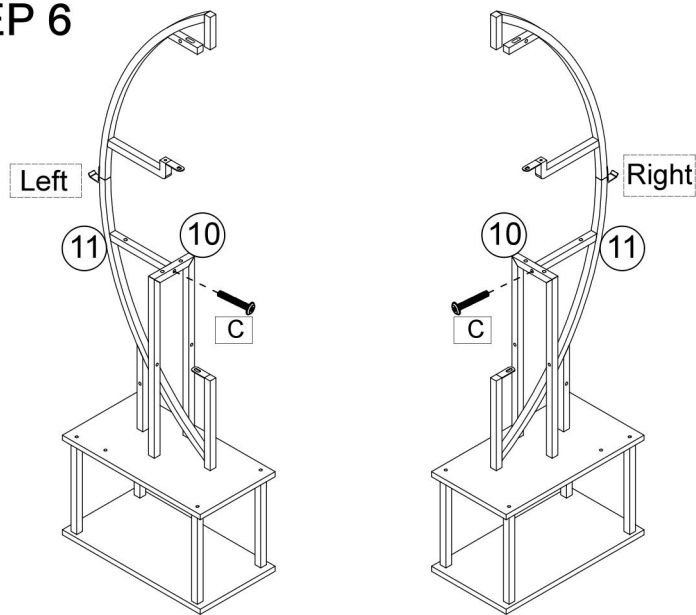

STEP 7

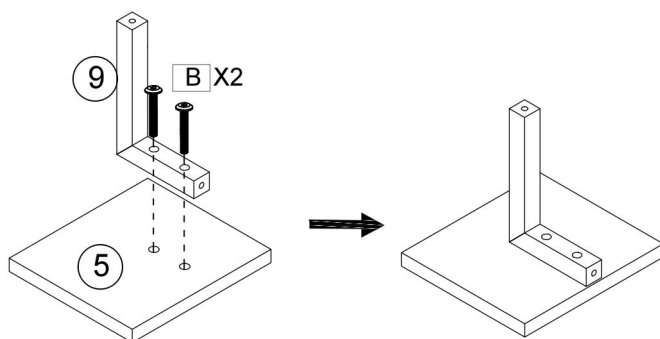

X2

ASSEMBLY INSTRUCTION

STEP 8

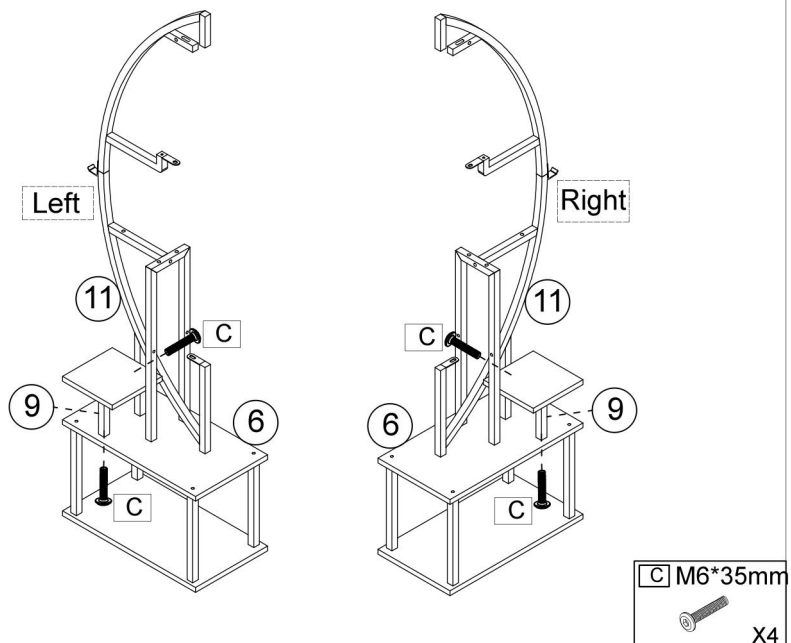

STEP 9

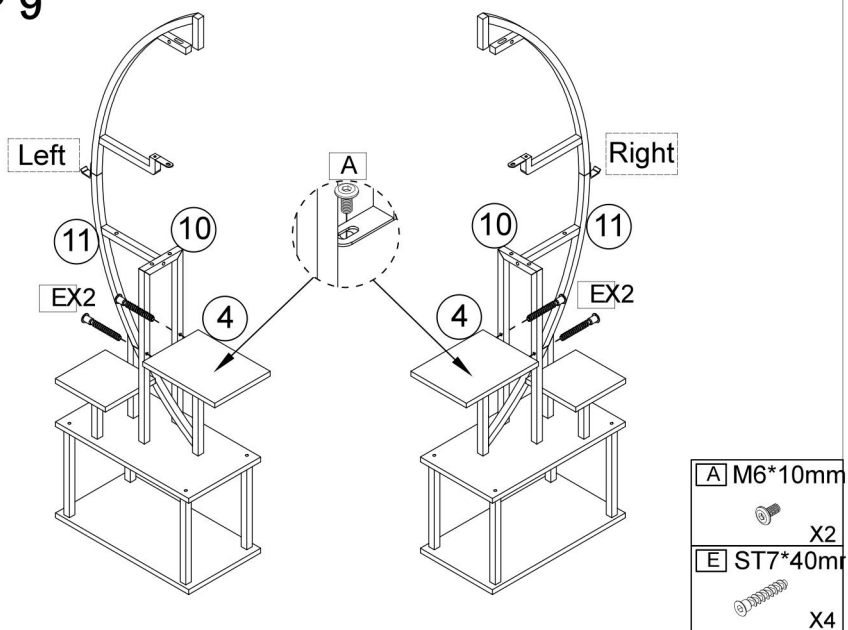

ASSEMBLY INSTRUCTION

STEP 10

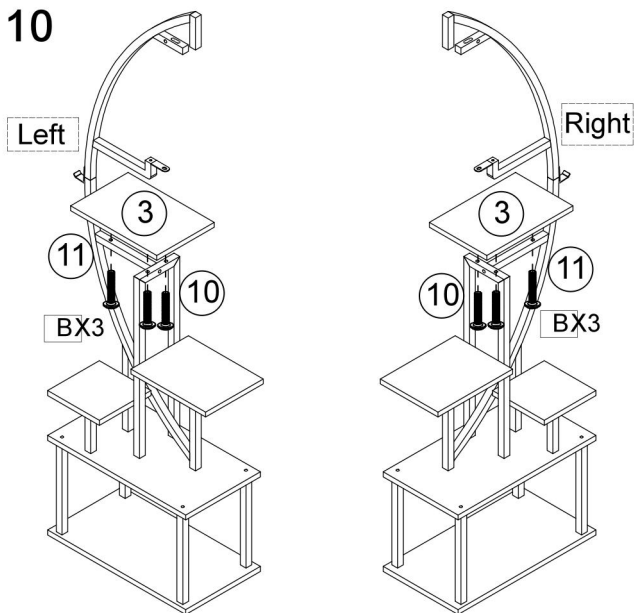

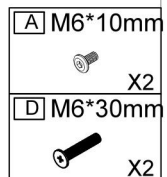
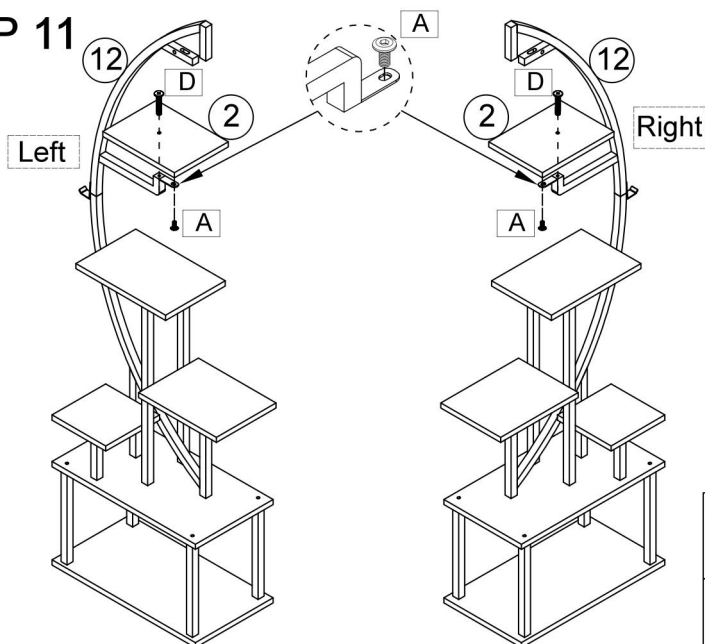

STEP 11

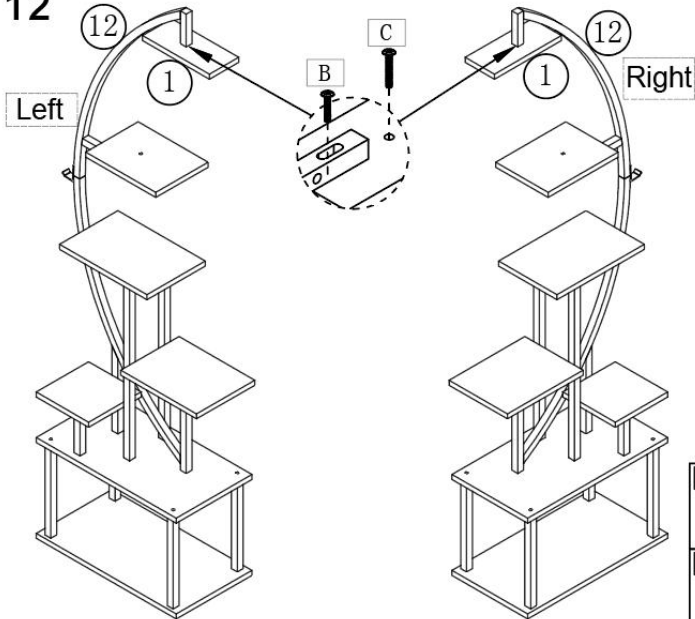

ASSEMBLY INSTRUCTION

STEP 12



B	M6*30mm
	X2
C	M6*35mm
	X2

STEP 13

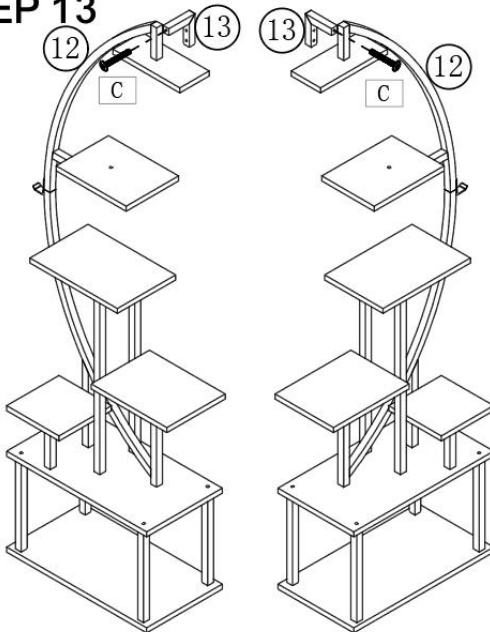



13



H

Anti-tilt



Note that you can choose an anti-tilt rack or fixing belt according to your needs.

If you select a fixed belt, please refer to steps 15-16

13		X2
C	M6*35mm	X2

ASSEMBLY INSTRUCTION

STEP 14

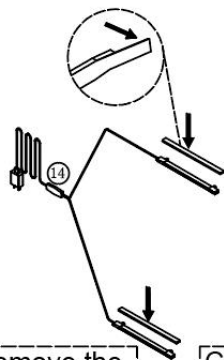

Carefully remove the plastic film behind the light strip

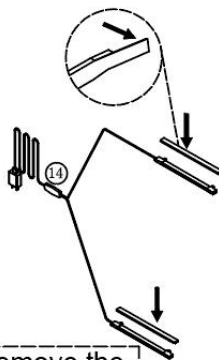

Carefully remove the plastic film behind the light strip

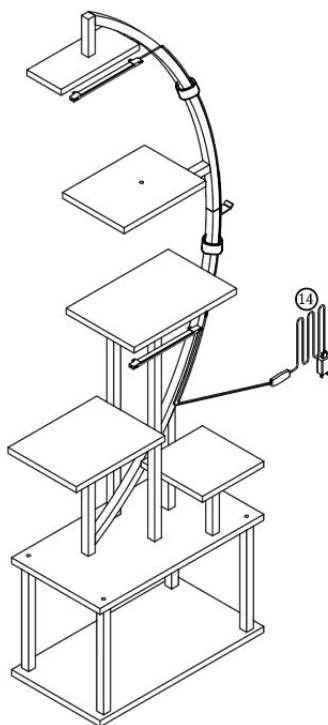
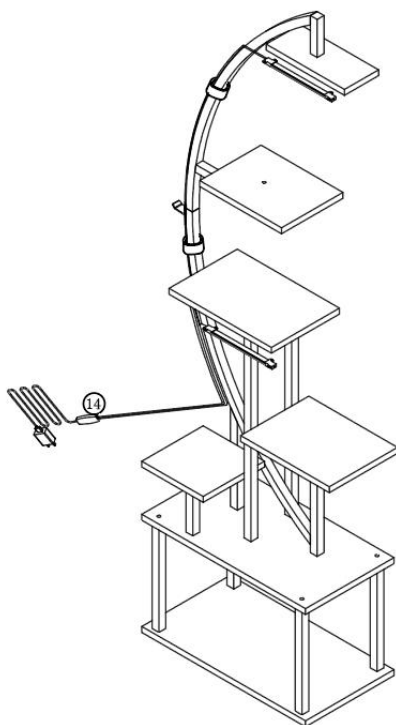

ASSEMBLY INSTRUCTION

STEP 15

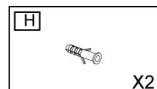
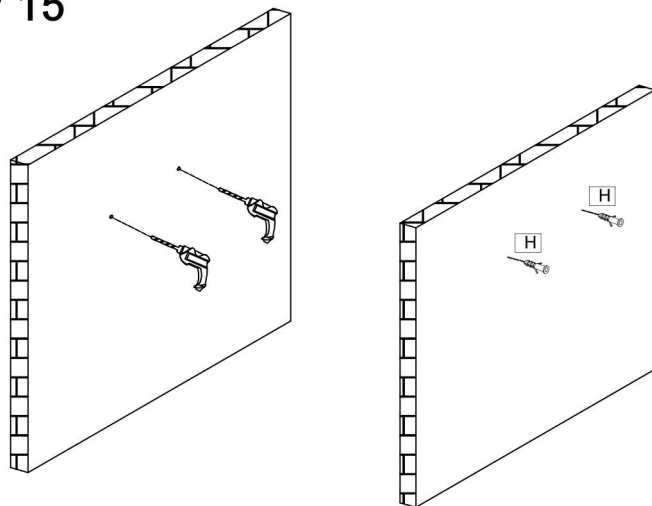

STEP 16

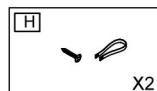
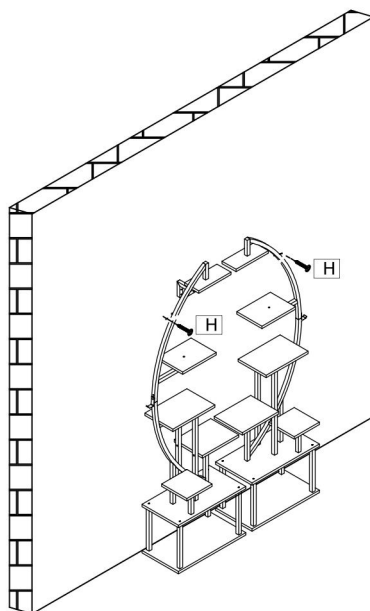

ASSEMBLY INSTRUCTION

STEP 17

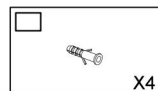
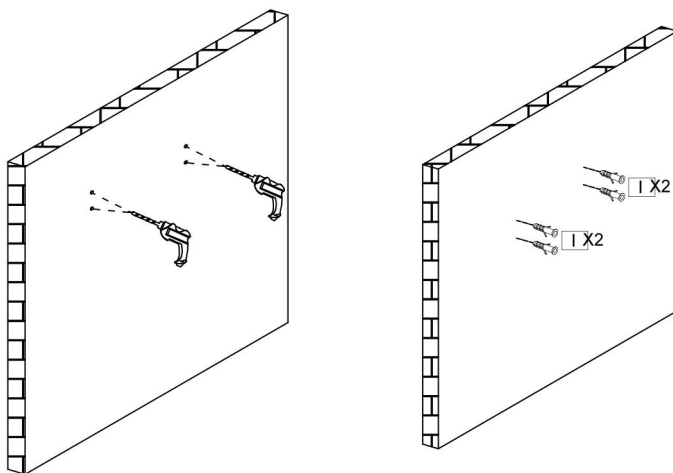

STEP 18

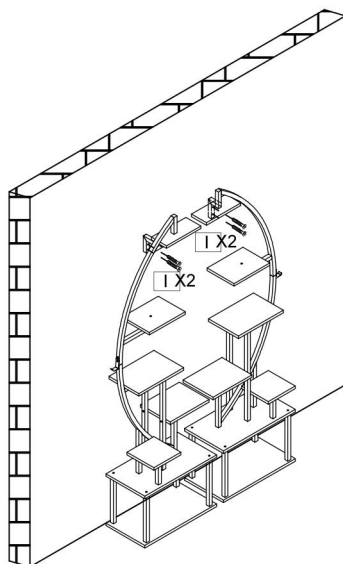

FCC INFORMATION

CAUTIONS: Changes or modifications not expressly approved by the party responsible for compliance could void the user's authority to operate the equipment!

This device complies with Part 15 of the FCC Rules. Operation is subject to the following two conditions:

- 1) This product may cause harmful interference.
- 2) This product must accept any interference received, including interference that may cause undesired operation.

WARNING: Changes or modifications not expressly approved by the party responsible for compliance could void the user's authority to operate the equipment.

NOTE: This equipment has been tested and found to comply with the limits for a Class B digital device, pursuant to Part 15 of the FCC Rules. These limits are designed to provide reasonable protection against harmful interference in a residential installation. This unit generates, uses, and can radiate radio frequency energy and if not installed and used in accordance with the instructions, may cause harmful interference to radio communications. However, there is no guarantee that interference will not occur in a particular installation. If this equipment does cause harmful interference to radio or television reception, which can be one or more of the following measures:

- Reorient or relocate the receiving antenna.
- Increase the separation between the equipment and receiver.
- Connect the equipment to an outlet on a circuit different from that to which the receiver is connected.
- Consult the dealer or an experienced radio/TV technician for help.

Manufacturer: Shanghaimuxinmuyeyouxiangongsi

Address: Shuangchenglu 803nong11hao1602A-1609shi, baoshanqu, shanghai 200000 CN.

Imported to USA: Sanven Technology Ltd. Suite 250, 9166 Anaheim Place, Rancho Cucamonga, CA 91730

UK	REP
-----------	------------

YH CONSULTING LIMITED. C/O YH Consulting
Limited Office 147, Centurion House, London
Road, Staines-upon-Thames, Surrey, TW18 4AX

EC	REP
-----------	------------

E-CrossStu GmbH
Mainzer Landstr.69,
60329 Frankfurt am Main.



VEVOR

Affordable. Reliable. Home Improvement.

SUPPORTS À PLANTES

(AVEC LAMPE DE CROISSANCE LED : ZWLDT-02)



MANUEL D'UTILISATION

MODÈLE: SSPS-0 3 - ÉTATS-UNIS \ SSPS-0 3 - UE

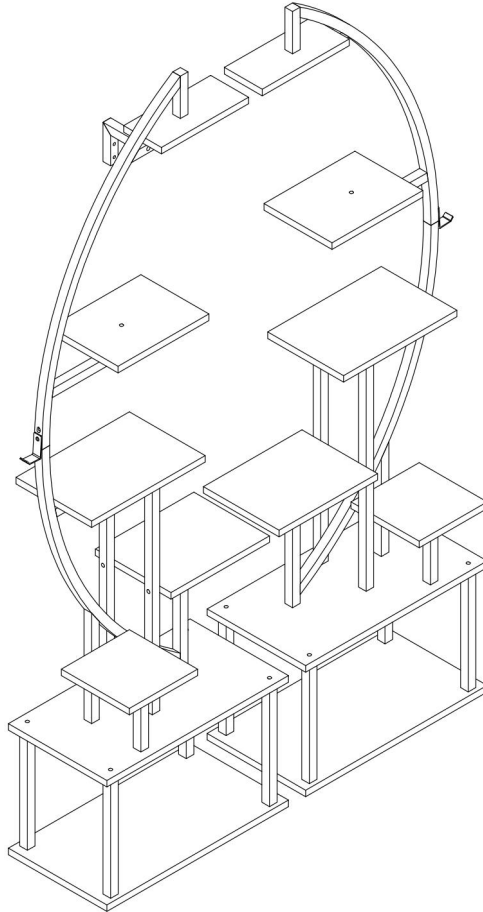
MODÈLE: SSPS-0 3 - ÉTATS-UNIS \ SSPS-0 3 - UE



Ceci est le mode d'emploi d'origine. Veuillez lire attentivement l'intégralité du manuel avant utilisation. VEVOR se réserve le droit d'interpréter clairement ce manuel d'utilisation. L'apparence du produit dépend du produit que vous avez reçu. Veuillez nous excuser pour les éventuelles mises à jour technologiques ou logicielles.

	<p>Avertissement - Pour réduire le risque de blessure, l'utilisateur doit lire attentivement le manuel d'instructions.</p> <p>LISEZ TOUTES LES INSTRUCTIONS AVANT UTILISATION</p> <p>Toutes les instructions de sécurité et d'utilisation doivent être lues, respectées et suivies avant la mise en service de l'appareil.</p>
	<p>Cet appareil est conforme à la partie 15 de la réglementation FCC. Son utilisation est soumise aux deux conditions suivantes : (1) Cet appareil ne doit pas provoquer d'interférences nuisibles ; (2) Il doit accepter toute interférence reçue, y compris celles susceptibles de provoquer un fonctionnement indésirable.</p>

SAFETY INSTRUCTIONS

Merci d'avoir acheté nos supports pour plantes .

- Avant d'utiliser ce produit, nous vous demandons de lire attentivement et de suivre les instructions ci-dessous. En installant ou en utilisant ce produit, vous reconnaissez avoir lu attentivement et accepté les consignes de sécurité suivantes.
- Veuillez vous assurer de conserver ce manuel pour référence ultérieure.

Remarques importantes :

- (1) La lampe de culture est destinée à un usage intérieur uniquement.
 - (2) La lampe de culture n'est pas étanche, ne laissez pas la lampe de culture tremper dans l'eau.
 - (3) Veuillez débrancher l'alimentation en cas d'orage.
 - (4) Veuillez vous assurer que le produit est utilisé dans un environnement normal.
- L'environnement de travail de la lampe doit être inférieure à +104 ° F et 80 % HR.

Consignes de sécurité :

- Le non-respect des instructions suivantes peut entraîner une utilisation anormale du produit ou des pertes inattendues. Nous vous recommandons vivement de respecter scrupuleusement ces consignes.
- Installez et utilisez le produit en stricte conformité avec les instructions fournies. instructions.

PRODUCT DESCRIPTION

- L'éclairage de culture à LED est une excellente option pour la culture des plantes, comparé aux éclairages traditionnels.
- La lampe de culture a un PPFd plus élevé, une consommation d'énergie plus faible et une durée de vie plus longue.





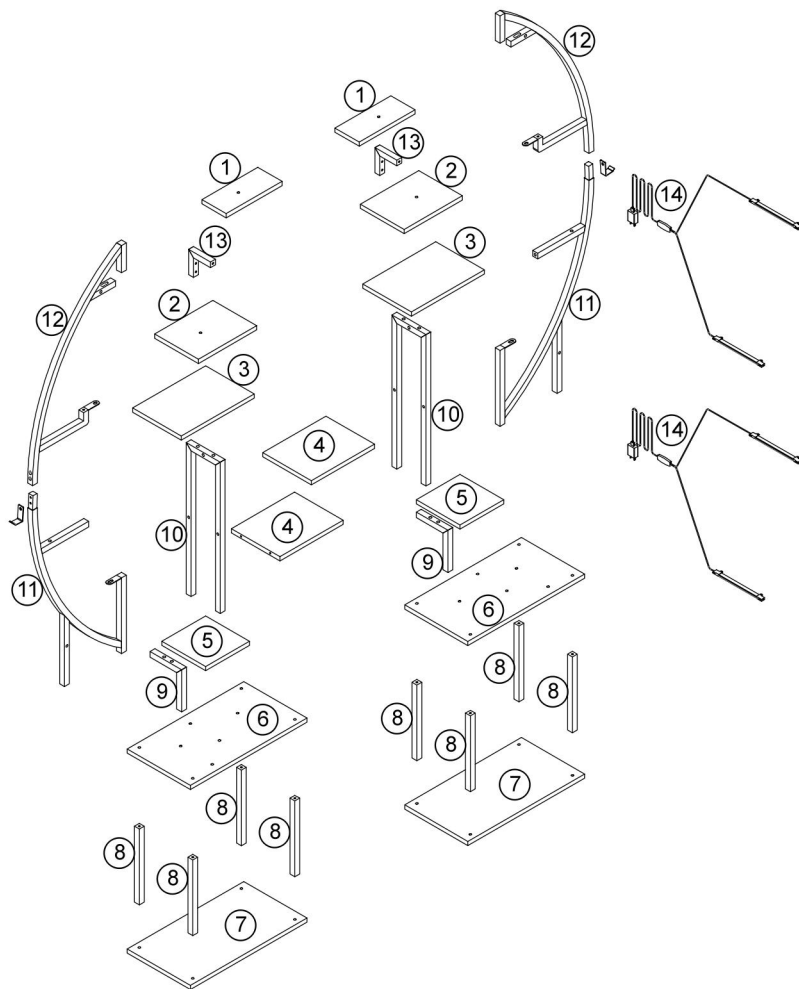

Modèle	SSPS-0 3 -États-Unis	SSPS-0 3 -UE
LAMPE DE CROISSANCE À LED	Z WLDT-02	
District	Amérique du Nord	Europe
Tension de l'adaptateur	CA 110 V ~ 120 V 60 Hz	CA 220 V ~ 240 V 50 Hz
Puissance lumineuse	5 à 6 W (Spectre complet) / 2 lumières	
Niveaux des étagères	7 niveaux	
Couleur	Marron et noir	
Matériel	Métaux et panneaux de particules	

PARTS LIST

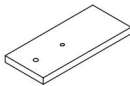
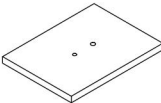
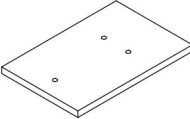
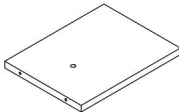
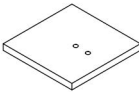
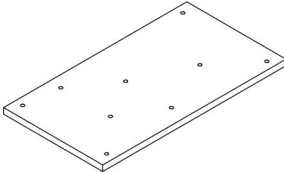
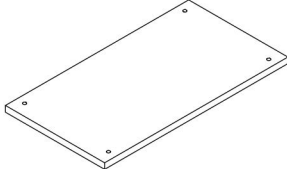

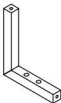
No.	PICTURE	SIZE	QTY	No.	PICTURE	SIZE	QTY
A		M6*10	8	G		S	2
B		M6*30	12	H			2
C		M6*35	18	I		ST5*40	4
D		M6*30	18				
E		ST7*40	4				
F		40*40*5	8				1

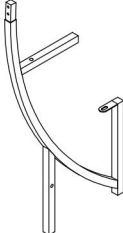
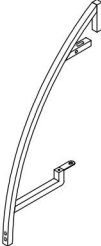
PARTS LIST

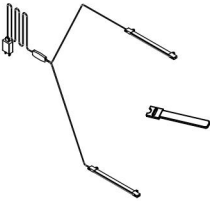
<p>1</p>  <p>X2</p>	<p>2</p>  <p>X2</p>	<p>3</p>  <p>X2</p>
<p>4</p>  <p>X2</p>	<p>5</p>  <p>X2</p>	<p>6</p>  <p>X2</p>
<p>7</p>  <p>X2</p>	<p>8</p>  <p>X8</p>	<p>9</p>  <p>X2</p>
<p>10</p>  <p>X2</p>	<p>11</p>  <p>X2</p>	<p>12</p>  <p>X2</p>
<p>13</p>  <p>X2</p>	<p>14</p>  <p>X2</p>	

ASSEMBLY INSTRUCTION

Matters needing attention

(1) When installing the screws in the installation step, the screws do not need to be tightened.

then tighten all the screws.

After this installation step is confirmed and the holes are aligned,

(2) If the screws are tightened during the installation process, it will cause problems such as misalignment of the screw holes and misalignment of the board in subsequent installations.

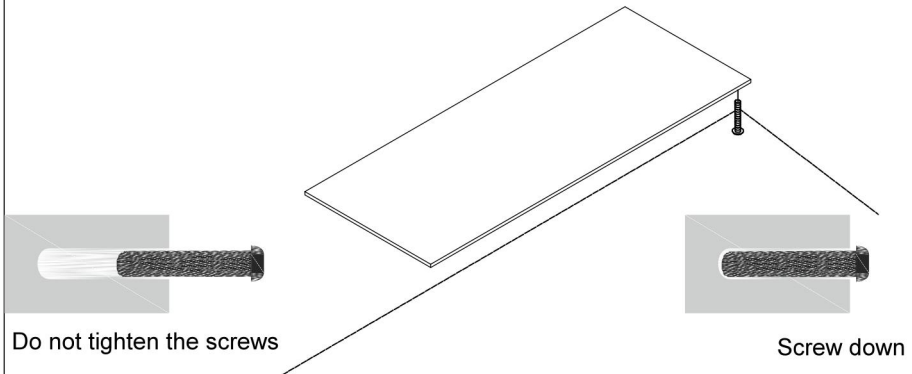

If you encounter any problems during the installation or use you can contact us at any time, we will resolve your issue within 24 hours

ASSEMBLY INSTRUCTION

STEP 1

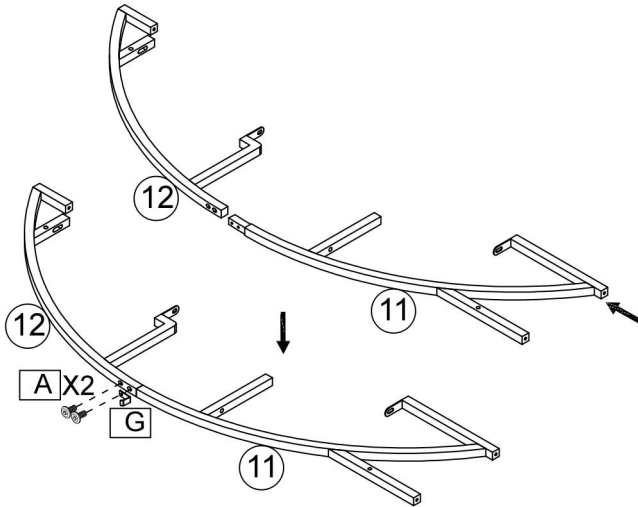

X2

A M6*10mm  X4	G  X2
--	--

STEP 2

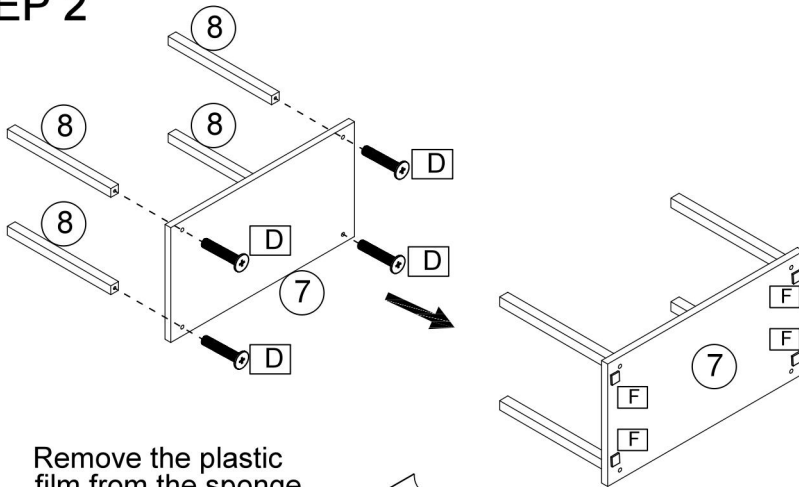

Remove the plastic film from the sponge pad before installation

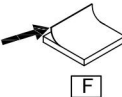

X2

D M6*30mm  X8	F 40*40*5mm  X8
--	--

ASSEMBLY INSTRUCTION

STEP 3

Please note that the left and right wooden boards can be interchanged, just flip the 6th board over.

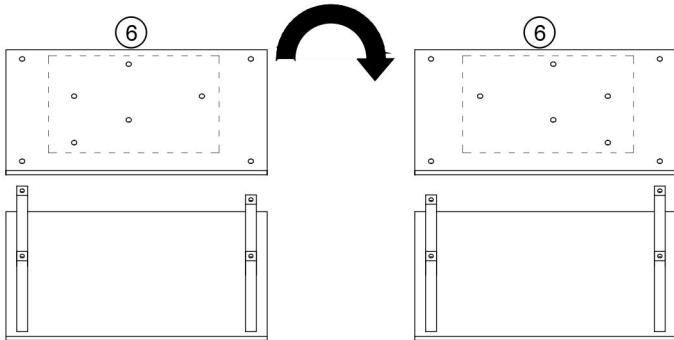

Note the direction of the hole in Board No. 6. The Hole in the left picture represents the left side, and the hole in the right picture represents the right side when the board No. 6 is reversed.

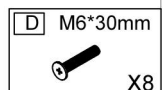
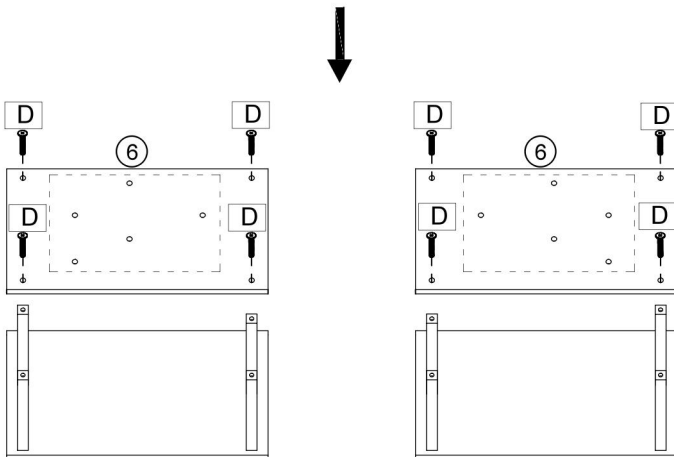

ASSEMBLY INSTRUCTION

STEP 4

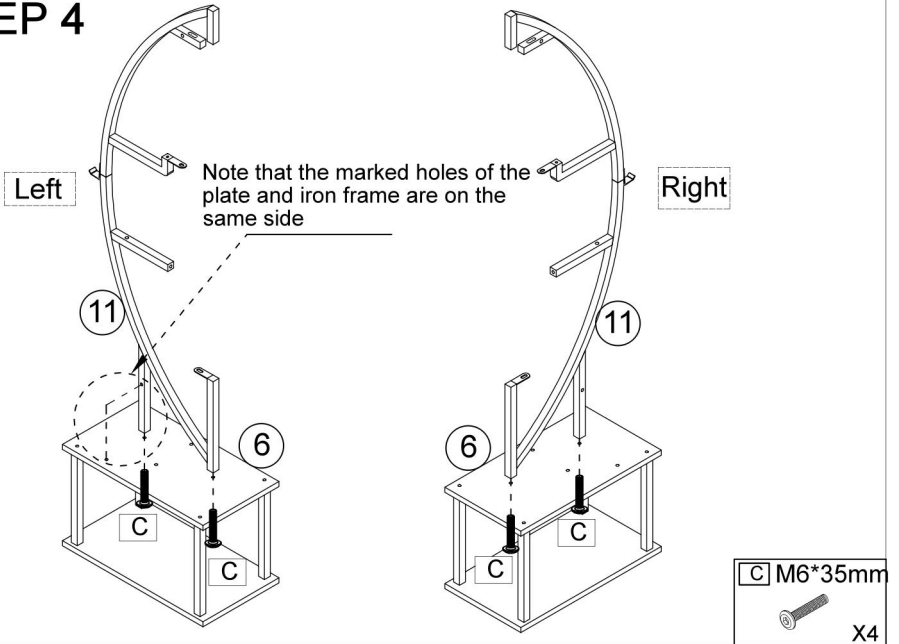

STEP 5

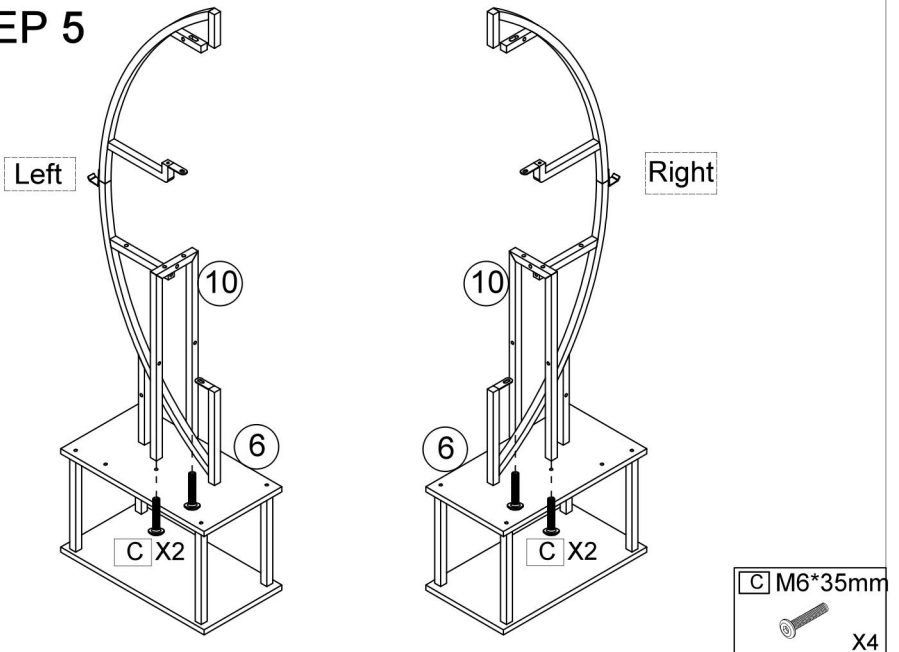

ASSEMBLY INSTRUCTION

STEP 6

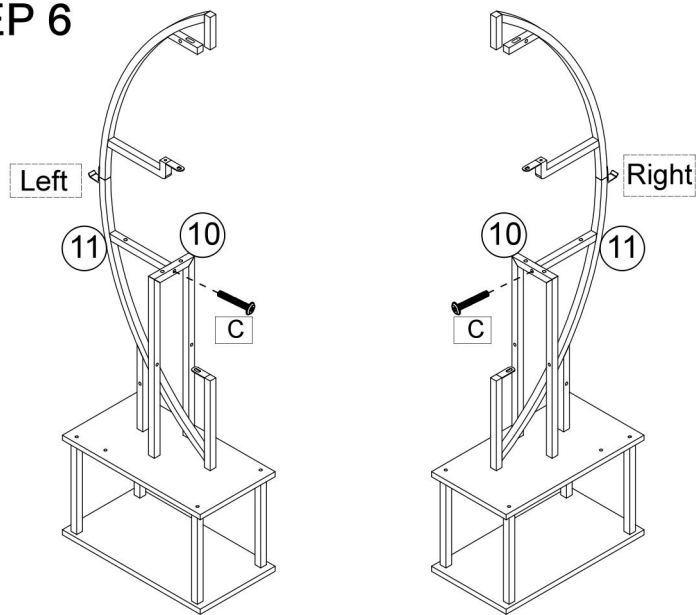

STEP 7

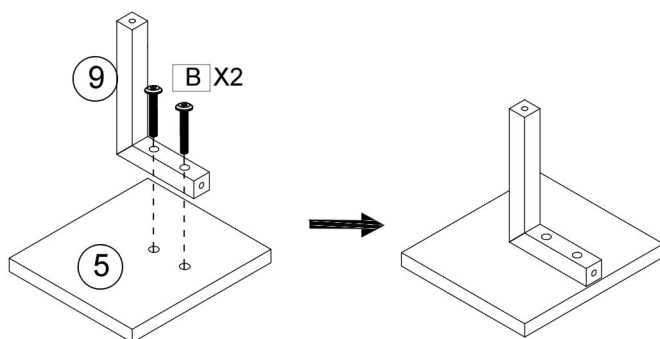

X2

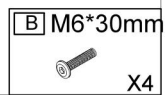

ASSEMBLY INSTRUCTION

STEP 8

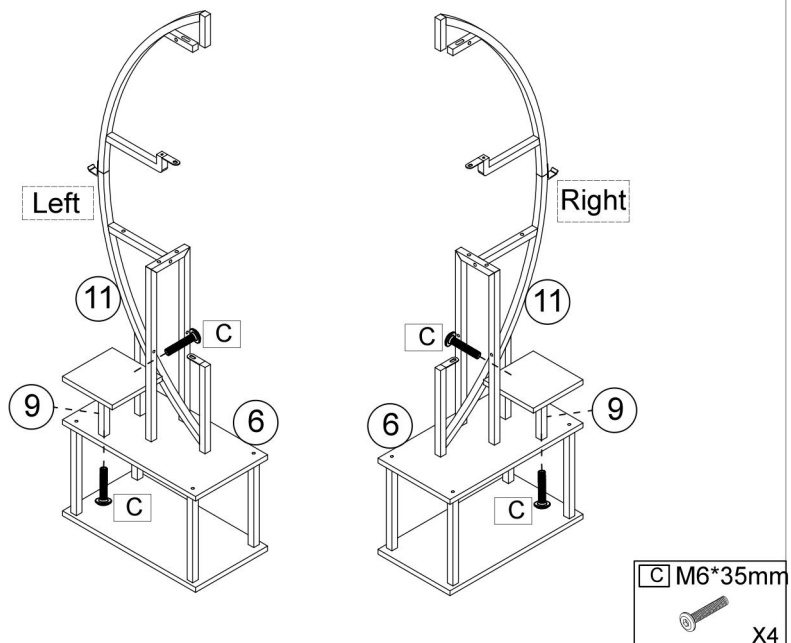

STEP 9

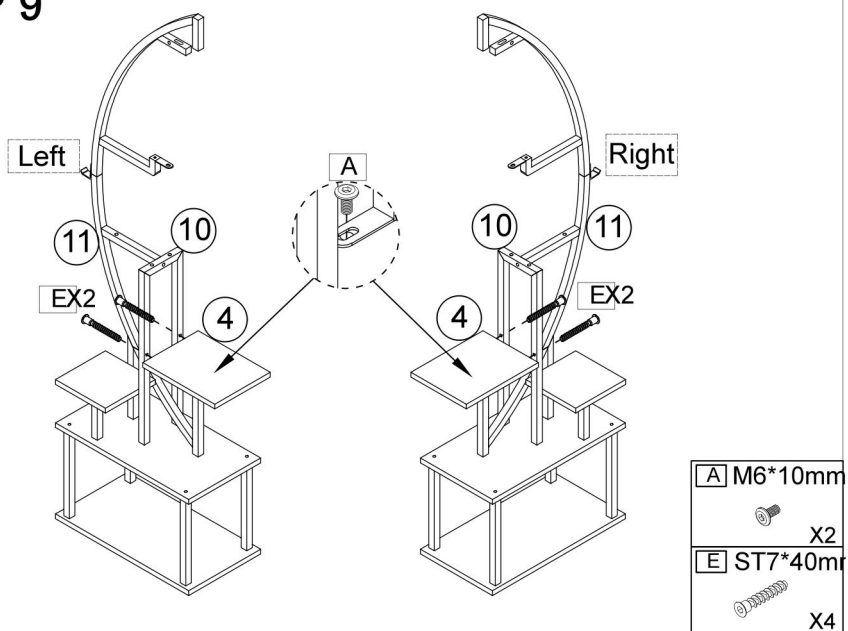

ASSEMBLY INSTRUCTION

STEP 10

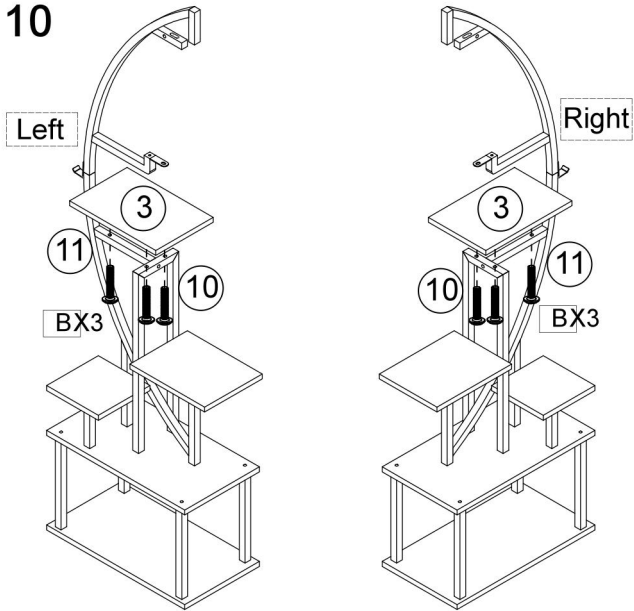

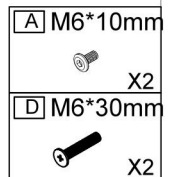
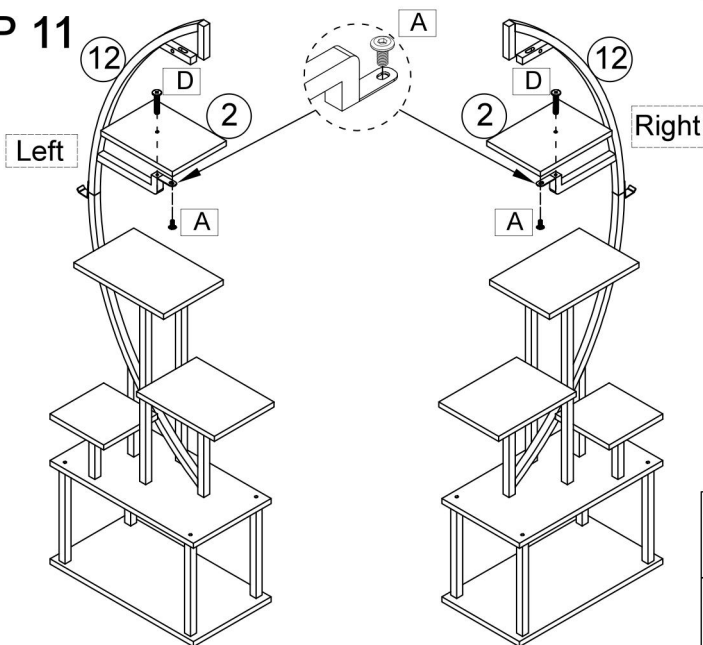

STEP 11

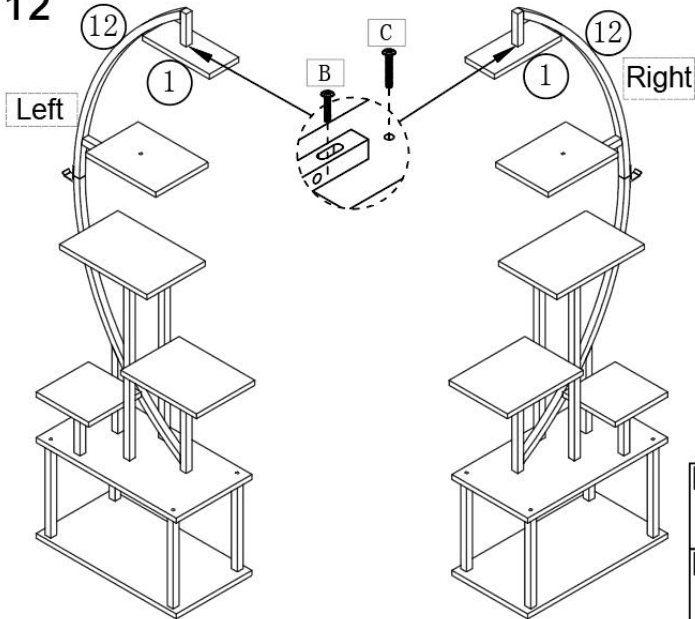

ASSEMBLY INSTRUCTION

STEP 12



B	M6*30mm
	X2
C	M6*35mm
	X2

STEP 13

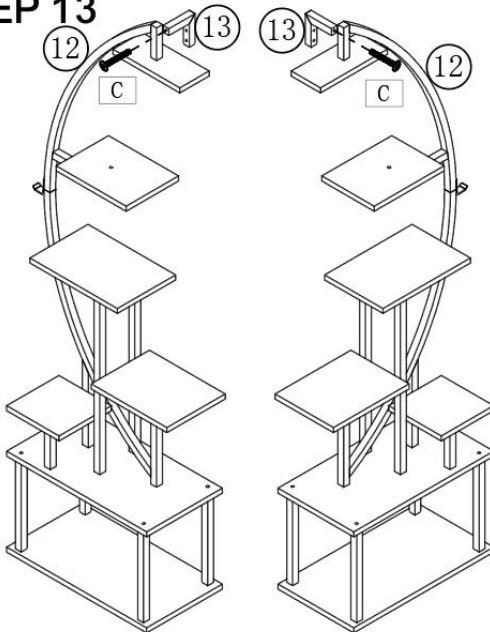



13





H

Anti-tilt



Note that you can choose an anti-tilt rack or fixing belt according to your needs.

If you select a fixed belt, please refer to steps 15-16

13		X2
C	M6*35mm	X2
		X2

ASSEMBLY INSTRUCTION

STEP 14

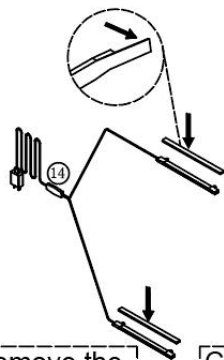

Carefully remove the plastic film behind the light strip

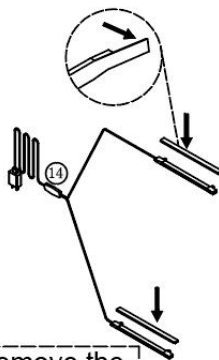

Carefully remove the plastic film behind the light strip

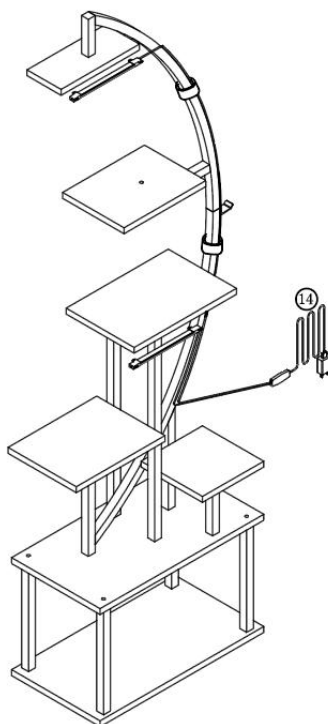
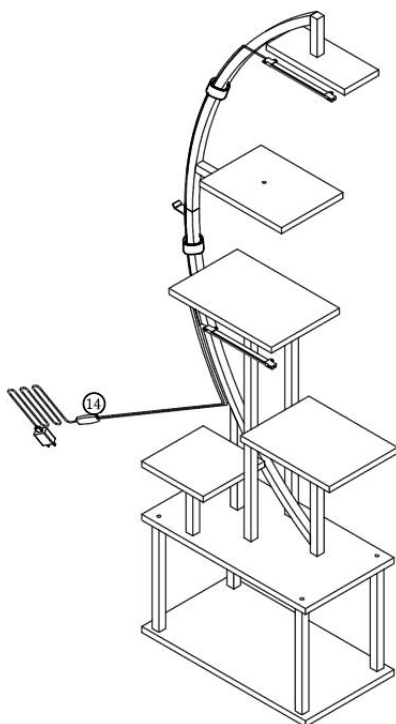

ASSEMBLY INSTRUCTION

STEP 15

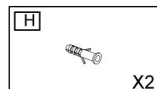
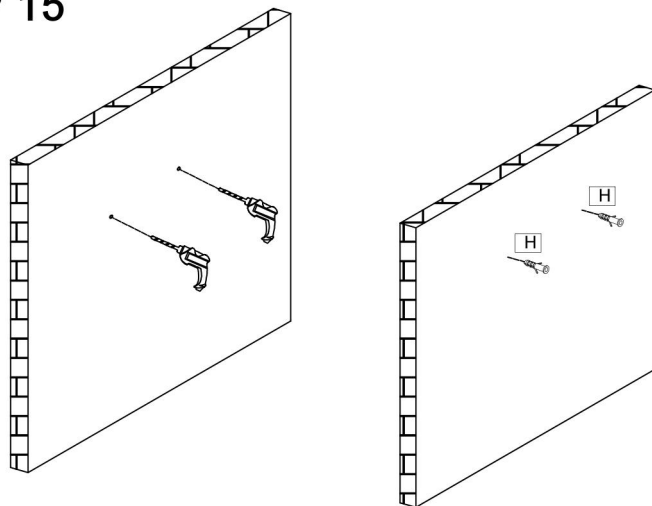

STEP 16

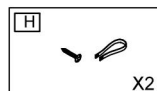
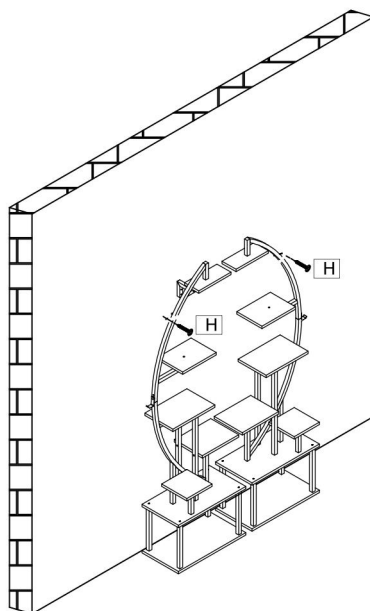

ASSEMBLY INSTRUCTION

STEP 17

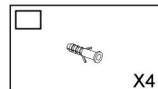
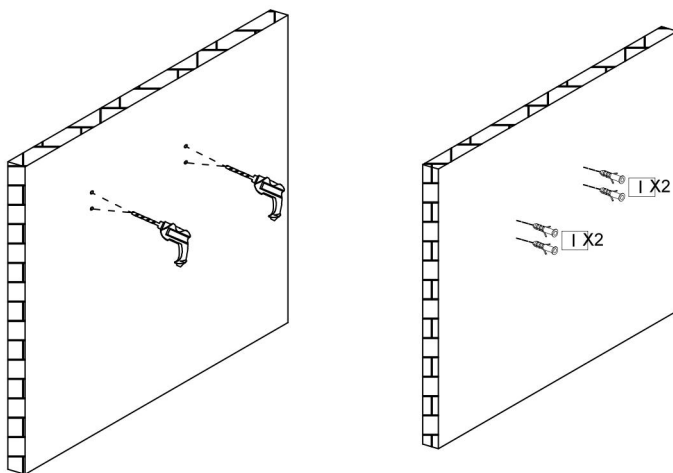

STEP 18

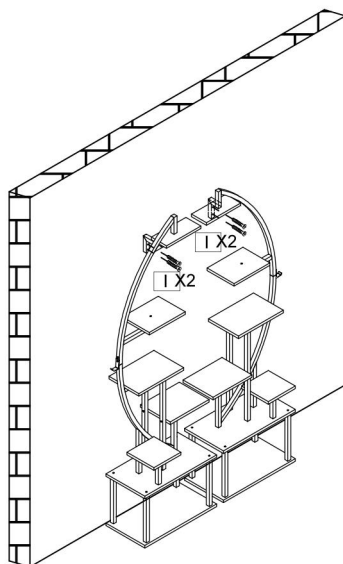

FCC INFORMATION

MISES EN GARDE : Les changements ou modifications non expressément approuvés par la partie responsable le non-respect de ces instructions pourrait annuler l'autorisation de l'utilisateur à utiliser l'équipement !

Cet appareil est conforme à la partie 15 de la réglementation FCC. Son utilisation est soumise aux conditions suivantes : deux conditions :

- 1) Ce produit peut provoquer des interférences nuisibles.
- 2) Ce produit doit accepter toute interférence reçue, y compris les interférences qui peuvent provoquer un fonctionnement indésirable.

AVERTISSEMENT : Les changements ou modifications non expressément approuvés par la partie responsable de la conformité pourraient annuler le droit de l'utilisateur à utiliser l'équipement.

REMARQUE : Cet équipement a été testé et déclaré conforme aux limites applicables aux appareils numériques de classe B, conformément à la partie 15 de la réglementation FCC. Ces limites visent à assurer une protection raisonnable contre les interférences nuisibles dans une installation résidentielle. Cet appareil génère, utilise et peut émettre des radiofréquences. S'il n'est pas installé et utilisé conformément aux instructions, il peut provoquer des interférences nuisibles aux communications radio. Cependant, rien ne garantit l'absence d'interférences dans une installation donnée. Si cet équipement provoque des interférences nuisibles à la réception radio ou télévisuelle, vous pouvez prendre une ou plusieurs des mesures suivantes :

- Réorienter ou déplacer l'antenne de réception.
- Augmenter la séparation entre l'équipement et le récepteur.
- Connectez l' équipement à une prise sur un circuit différent de celui auquel le récepteur est connecté.
- Consultez le revendeur ou un technicien radio/TV expérimenté pour obtenir de l'aide.

Fabricant: Shanghaimuxinmuyeyouxiangongsi

Adresse: Shuangchenglu 803nong11hao1602A-1609shi, baoshanqu ,
Shanghai 200 000 CN.

Importé aux États-Unis : Sanven Technology Ltd. Suite 250, 9166
Anaheim

Lieu, Rancho Cucamonga, CA 91730

UK	REP
-----------	------------

YH CONSULTING LIMITED. C/O YH Consulting
Limited Office 147, Centurion House, London
Road, Staines-upon-Thames, Surrey, TW18 4AX

EC	REP
-----------	------------

E-CrossStu GmbH
Mainzer Landstr.69,
60329 Frankfurt am Main.



VEVOR

Affordable. Reliable. Home Improvement.

PFLANZENSTÄNDER

(MIT LED-WACHSTUMSLICHT : ZWLDT-02)



BENUTZERHANDBUCH

MODELL: SSPS-0 3 -US \ SSPS-0 3 - EU

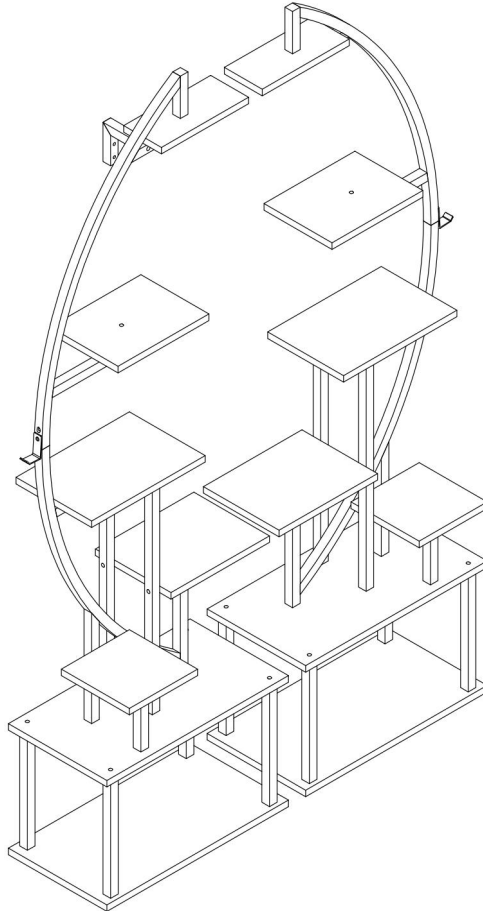
MODELL: SSPS-0 3 -US \ SSPS-0 3 - EU



Dies ist die Originalanleitung. Bitte lesen Sie alle Anweisungen sorgfältig durch, bevor Sie das Gerät in Betrieb nehmen. VEVOR behält sich das Recht vor, die Bedienungsanleitung klar und deutlich zu interpretieren. Das Aussehen des Produkts hängt vom gelieferten Produkt ab. Bitte haben Sie Verständnis dafür, dass wir Sie nicht erneut über Technologie- oder Software-Updates informieren.

	<p>Warnung: Um das Verletzungsrisiko zu verringern, muss der Benutzer die Bedienungsanleitung sorgfältig lesen.</p> <p>LESEN SIE ALLE ANWEISUNGEN VOR DER VERWENDUNG</p> <p>Alle Sicherheits- und Bedienungshinweise sollten gelesen werden, vor der Inbetriebnahme des Geräts beachtet und befolgt werden.</p>
	<p>Dieses Gerät entspricht Teil 15 der FCC-Bestimmungen. Der Betrieb unterliegt den folgenden zwei Bedingungen: (1) Dieses Gerät darf keine schädlichen Störungen verursachen und (2) es muss alle empfangenen Störungen tolerieren, auch solche, die zu unerwünschtem Betrieb führen können.</p>

SAFETY INSTRUCTIONS

Vielen Dank für den Kauf unserer Pflanzenständer .

- Bevor Sie das Produkt verwenden, lesen Sie bitte die folgenden Anweisungen sorgfältig durch und befolgen Sie sie. Mit der Installation oder Verwendung des Produkts bestätigen Sie, dass Sie die folgenden Sicherheitshinweise sorgfältig gelesen und akzeptiert haben.
- Bitte bewahren Sie dieses Handbuch zum späteren Nachschlagen auf.

Wichtige Hinweise:

- (1) Die Wachstumslampe ist nur für den Gebrauch in Innenräumen bestimmt.
- (2) Das Wachstumslicht ist nicht wasserdicht. Lassen Sie das Wachstumslicht nicht in Wasser einweichen.
- (3) Bitte trennen Sie die Stromversorgung, wenn es gedonnert hat.
- (4) Bitte stellen Sie sicher, dass das Produkt in einer normalen Umgebung verwendet wird. Die Arbeitsumgebung der Lampe sollte unter +40 ° C und 80 % relativer Luftfeuchtigkeit liegen.

Sicherheitshinweise:

- Die Nichtbeachtung der folgenden Anweisungen kann zu unsachgemäßer Verwendung des Produkts oder unerwarteten Schäden führen. Wir empfehlen Ihnen dringend , die folgenden Richtlinien strikt einzuhalten.
- Installieren und verwenden Sie das Produkt ausschließlich gemäß den bereitgestellten Anweisungen.

PRODUCT DESCRIPTION

- LED-Wachstumslicht ist im Vergleich zu herkömmlichem Wachstumslicht eine hervorragende Option für den Pflanzenanbau.
- Wachstumslicht hat eine höhere PPF, einen geringeren Stromverbrauch und eine längere Lebensdauer.



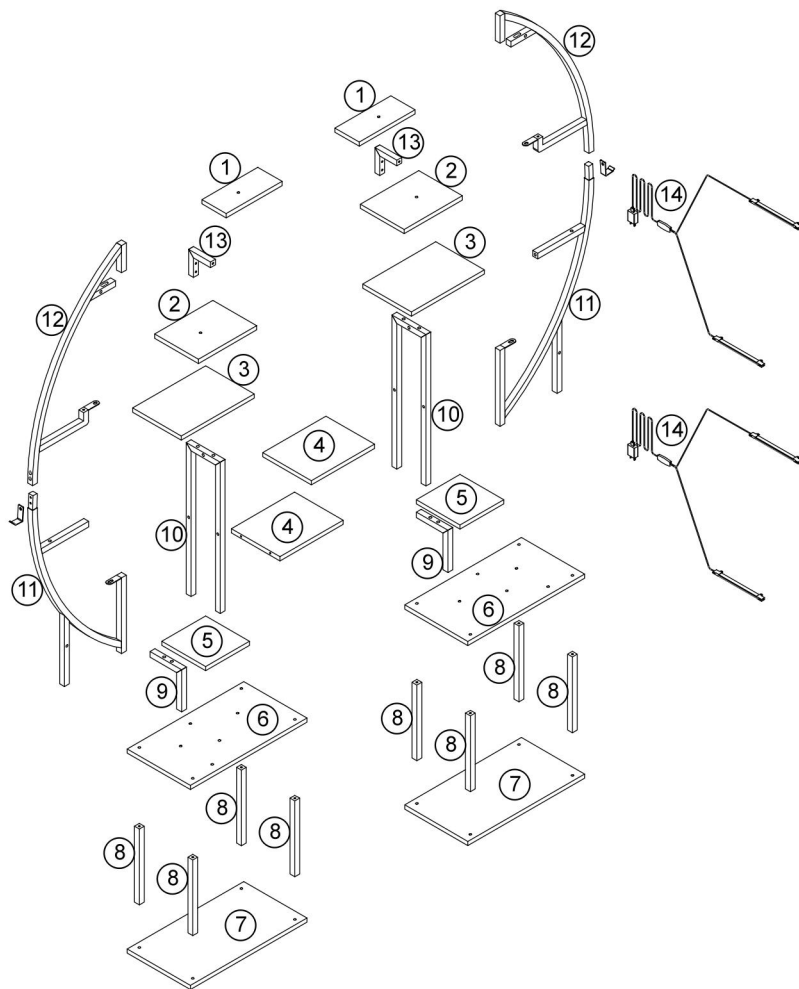

Modell	SSPS-0 3 -US	SSPS-0 3 -EU
LED-WACHSTUMSLICHT	Z WLDT-02	
Bezirk	Nordamerika	Europa
Adapterspannung	Wechselstrom 110 V ~ 120 V 60 Hz	Wechselstrom 220 V – 240 V, 50 Hz
Lichtleistung	5–6 W (Vollspektrum) / 2 Lichter	
Regalebenen	7 Stufen	
Farbe	Braun & Schwarz	
Material	Metalle & Spanplatten	

PARTS LIST

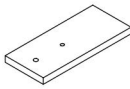
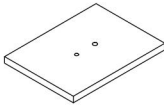
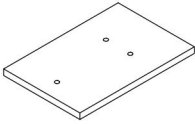
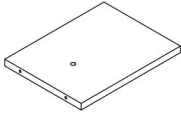
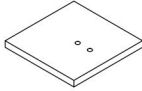
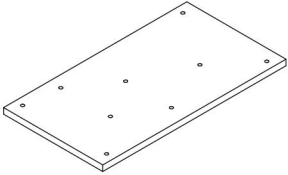
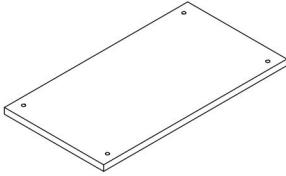

No.	PICTURE	SIZE	QTY	No.	PICTURE	SIZE	QTY
A		M6*10	8	G		S	2
B		M6*30	12	H			2
C		M6*35	18	I		ST5*40	4
D		M6*30	18				
E		ST7*40	4				
F		40*40*5	8				1

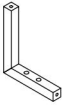
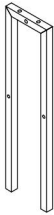
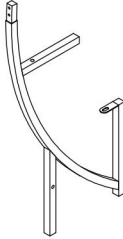
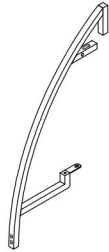
PARTS LIST

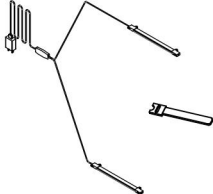
<p>1</p>  <p>X2</p>	<p>2</p>  <p>X2</p>	<p>3</p>  <p>X2</p>
<p>4</p>  <p>X2</p>	<p>5</p>  <p>X2</p>	<p>6</p>  <p>X2</p>
<p>7</p>  <p>X2</p>	<p>8</p>  <p>X8</p>	<p>9</p>  <p>X2</p>
<p>10</p>  <p>X2</p>	<p>11</p>  <p>X2</p>	<p>12</p>  <p>X2</p>
<p>13</p>  <p>X2</p>	<p>14</p>  <p>X2</p>	

ASSEMBLY INSTRUCTION

Matters needing attention

(1) When installing the screws in the installation step, the screws do not need to be tightened.

then tighten all the screws.

After this installation step is confirmed and the holes are aligned,

(2) If the screws are tightened during the installation process, it will cause problems such as misalignment of the screw holes and misalignment of the board in subsequent installations.

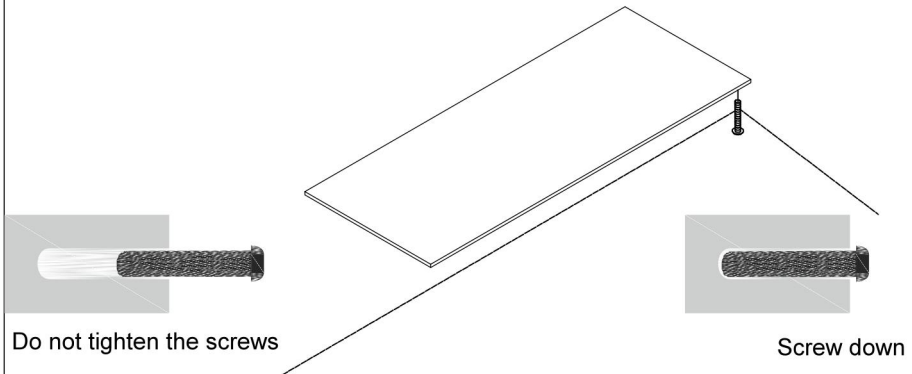

If you encounter any problems during the installation or use you can contact us at any time, we will resolve your issue within 24 hours

ASSEMBLY INSTRUCTION

STEP 1

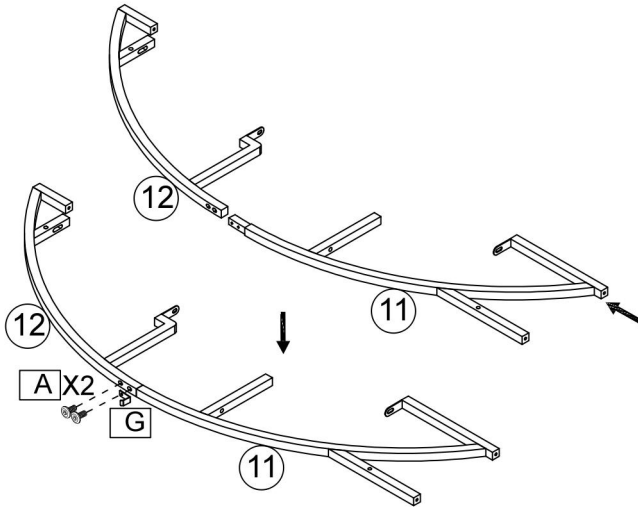

X2

A M6*10mm  X4	G  X2
--	--

STEP 2

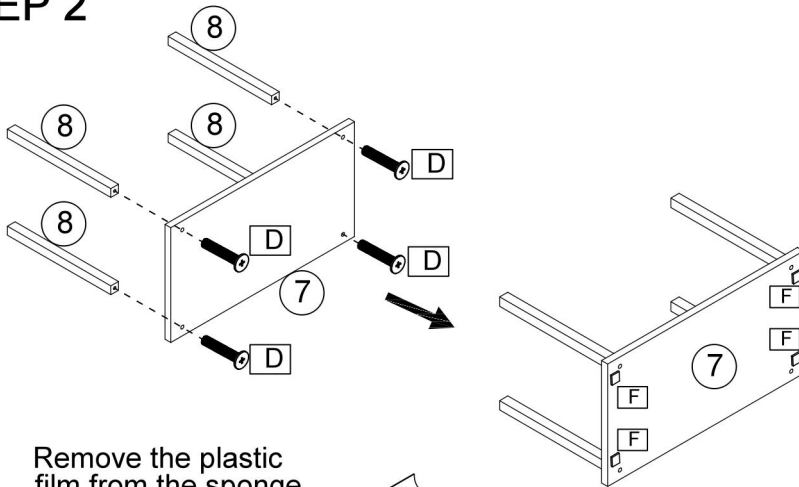

Remove the plastic film from the sponge pad before installation

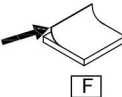

X2

D M6*30mm  X8	F 40*40*5mm  X8
--	--

ASSEMBLY INSTRUCTION

STEP 3

Please note that the left and right wooden boards can be interchanged, just flip the 6th board over.

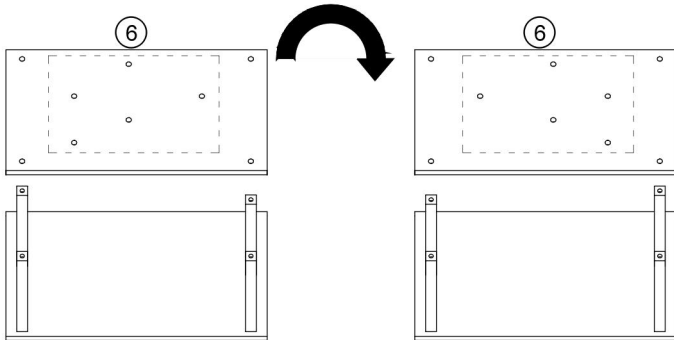

Note the direction of the hole in Board No. 6. The Hole in the left picture represents the left side, and the hole in the right picture represents the right side when the board No. 6 is reversed.

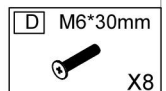
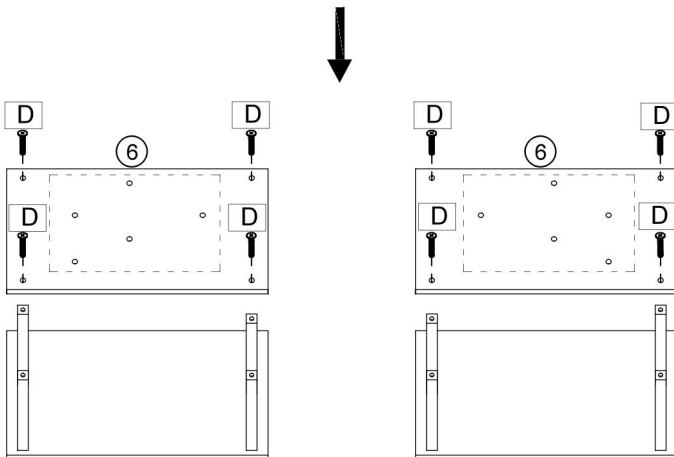

ASSEMBLY INSTRUCTION

STEP 4

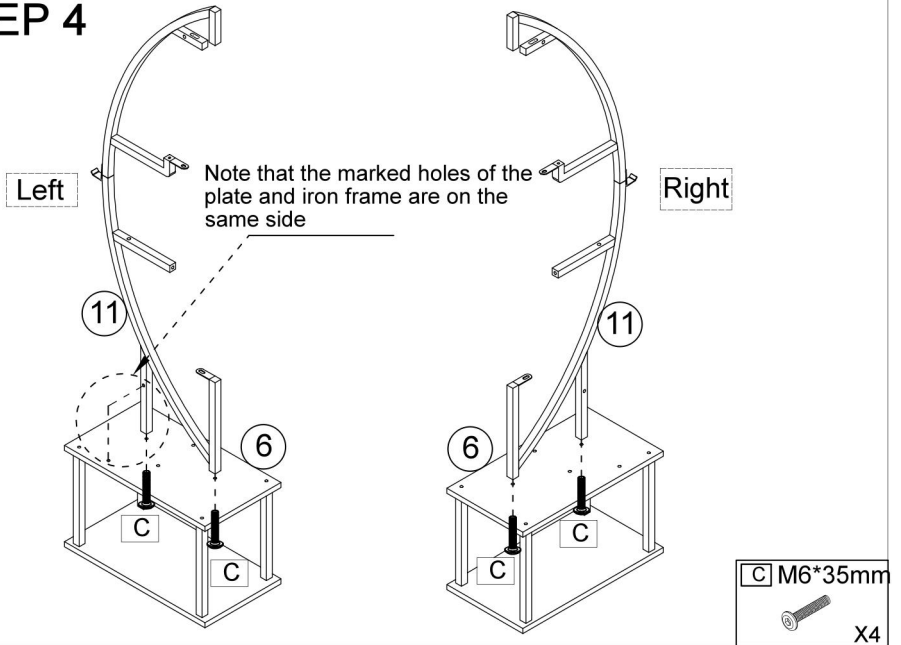

STEP 5

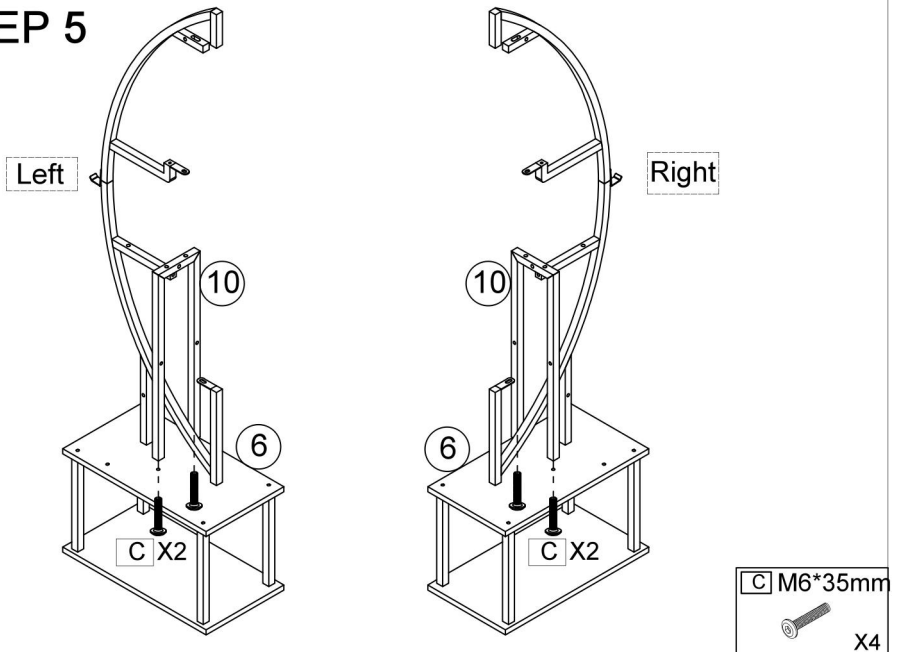

ASSEMBLY INSTRUCTION

STEP 6

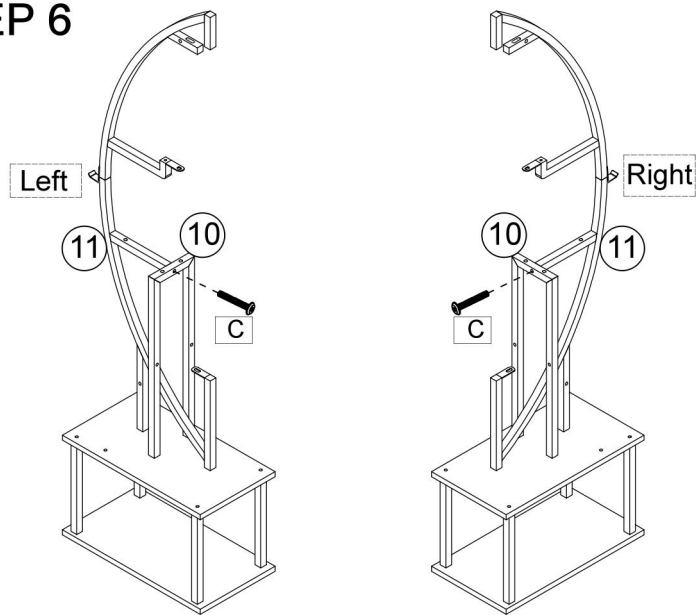

STEP 7

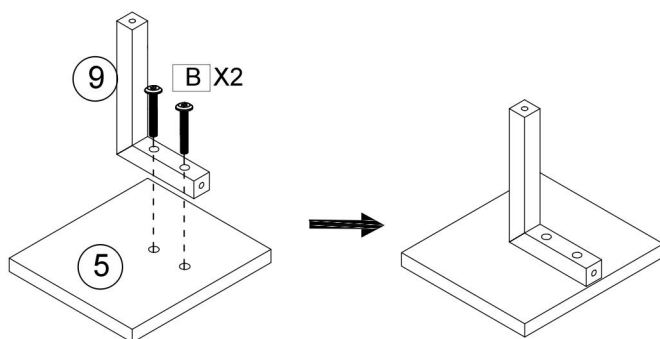

X2

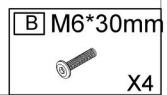

ASSEMBLY INSTRUCTION

STEP 8

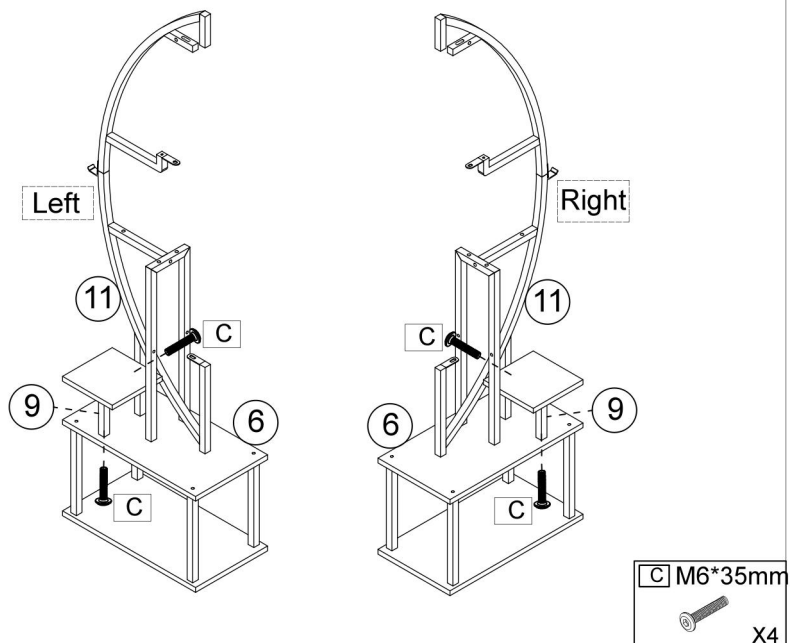

STEP 9

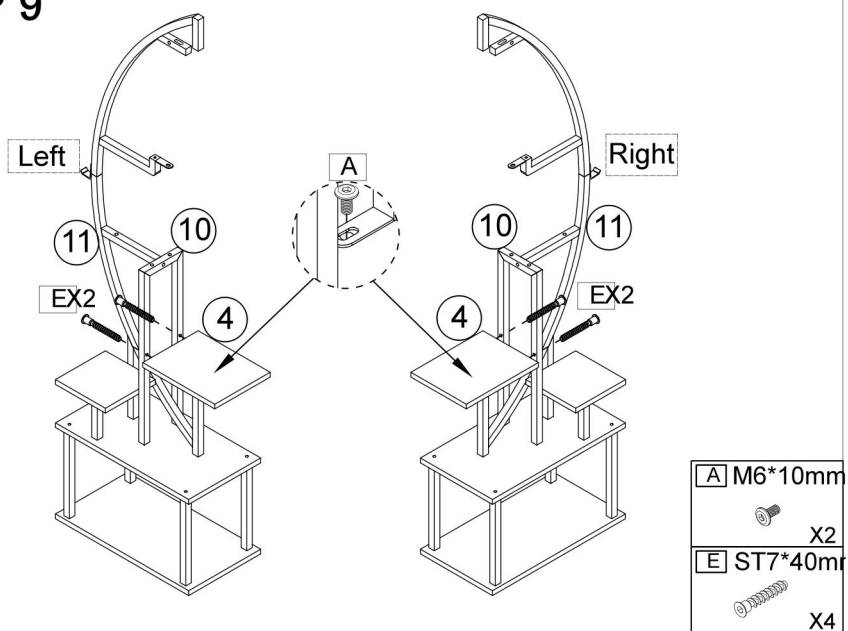

ASSEMBLY INSTRUCTION

STEP 10

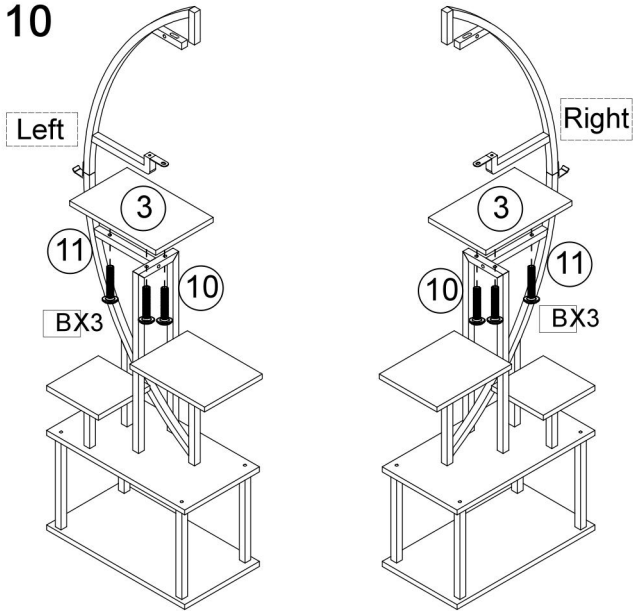

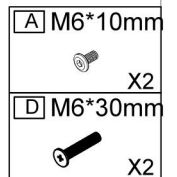
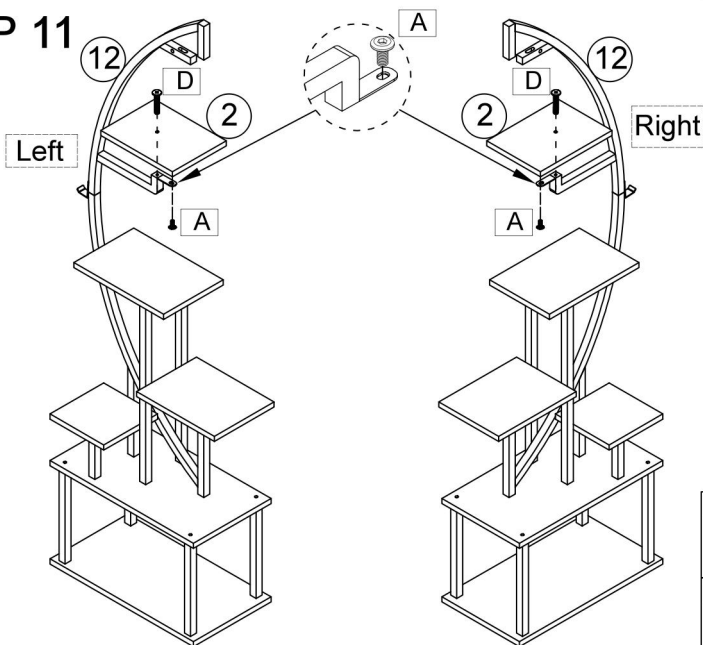

STEP 11

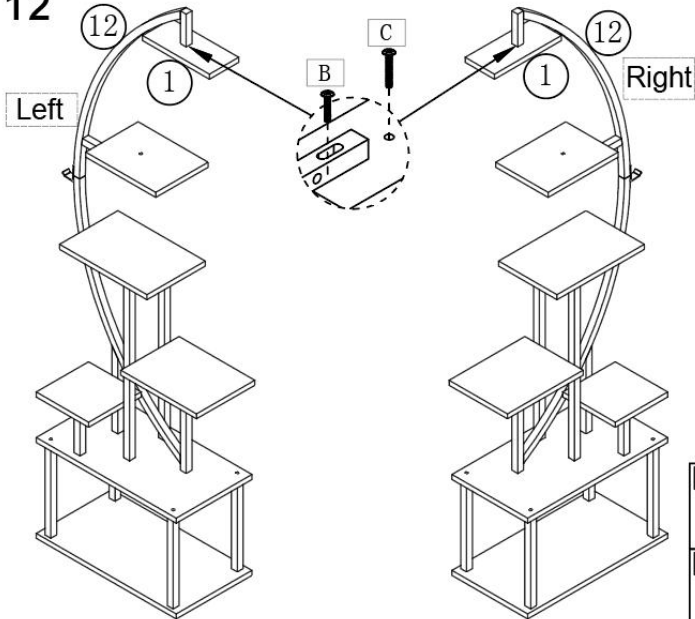

ASSEMBLY INSTRUCTION

STEP 12



B	M6*30mm
	X2
C	M6*35mm
	X2

STEP 13

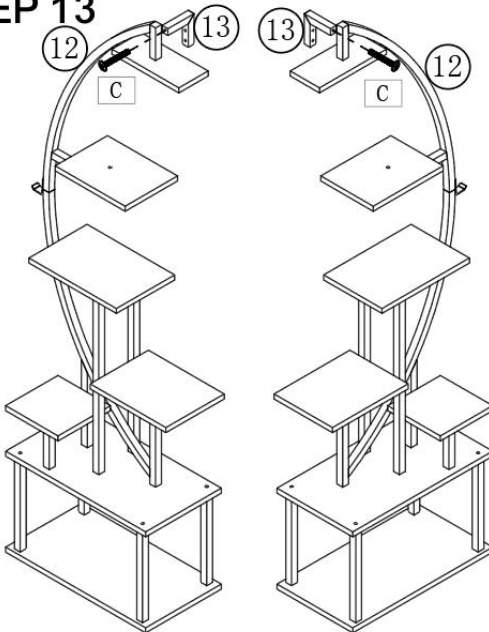



13



H

Anti-tilt



Note that you can choose an anti-tilt rack or fixing belt according to your needs.

If you select a fixed belt, please refer to steps 15-16

13		X2
C	M6*35mm	X2

ASSEMBLY INSTRUCTION

STEP 14

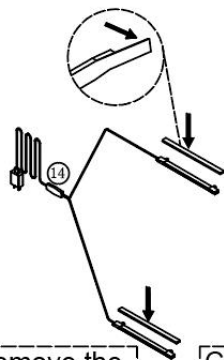

Carefully remove the plastic film behind the light strip

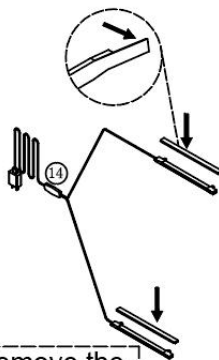

Carefully remove the plastic film behind the light strip

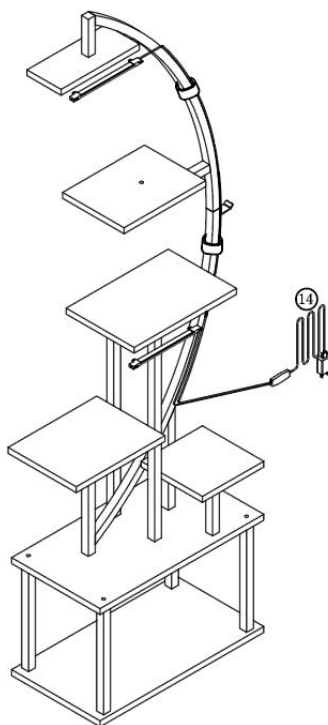
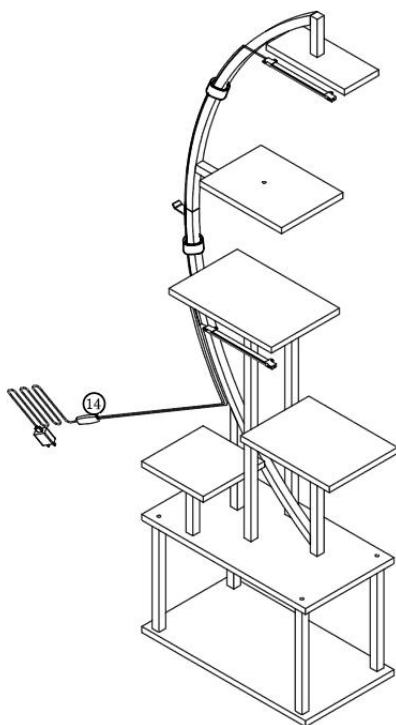

ASSEMBLY INSTRUCTION

STEP 15

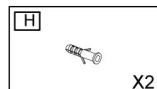
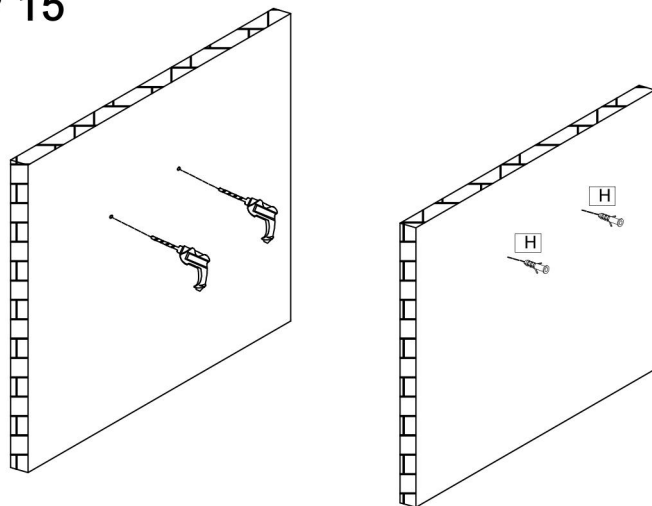

STEP 16

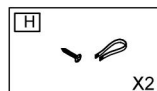
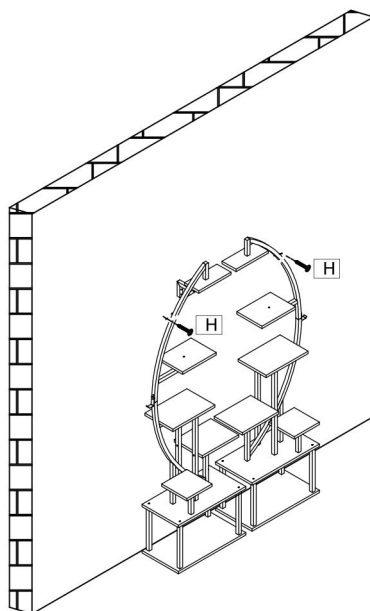

ASSEMBLY INSTRUCTION

STEP 17

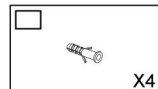
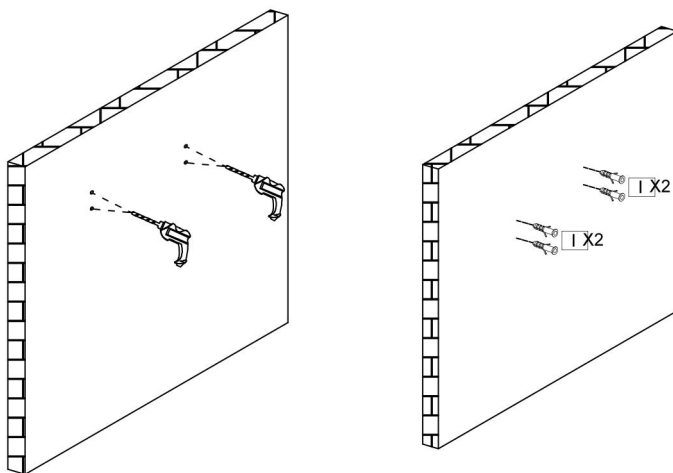

STEP 18

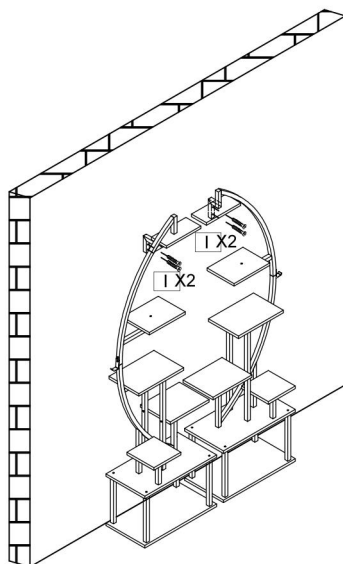

FCC INFORMATION

VORSICHTSMASSNAHMEN: Änderungen oder Modifikationen, die nicht ausdrücklich von der verantwortlichen Partei genehmigt wurden. Bei Nichtbeachtung kann die Berechtigung des Benutzers zum Betrieb des Geräts erlöschen!

Dieses Gerät entspricht Teil 15 der FCC-Bestimmungen. Der Betrieb unterliegt den folgenden zwei Bedingungen:

- 1) Dieses Produkt kann schädliche Störungen verursachen.
- 2) Dieses Produkt muss alle empfangenen Störungen akzeptieren, einschließlich Störungen, die zu unerwünschtem Betrieb führen.

WARNUNG: Änderungen oder Modifikationen, die nicht ausdrücklich von der für die Konformität verantwortlichen Partei genehmigt wurden, können zum Erlöschen der Berechtigung des Benutzers zum Betrieb des Geräts führen.

HINWEIS: Dieses Gerät wurde geprüft und entspricht den Grenzwerten für digitale Geräte der Klasse B gemäß Teil 15 der FCC-Bestimmungen. Diese Grenzwerte sollen einen angemessenen Schutz vor Störungen in Wohngebäuden gewährleisten. Dieses Gerät erzeugt, nutzt und strahlt Hochfrequenzenergie ab. Bei unsachgemäßer Installation und Verwendung kann es zu Störungen des Funkverkehrs kommen. Es besteht jedoch keine Garantie dafür, dass bei einer bestimmten Installation keine Störungen auftreten. Sollte dieses Gerät Störungen des Radio- oder Fernsehempfangs verursachen, können Sie eine oder mehrere der folgenden Maßnahmen ergreifen:

- Richten Sie die Empfangsantenne neu aus oder verlegen Sie ihren Standort.
- Vergrößern Sie den Abstand zwischen Gerät und Empfänger.
- Schließen Sie das Gerät an eine Steckdose an, die zu einem anderen Stromkreis gehört als der Empfänger.
- Wenden Sie sich an den Händler oder einen erfahrenen Radio-/Fernsehtechniker.

Hersteller: Shanghai muxinmuyeyouxiangongsi

Adresse: Shuangchenglu 803nong11hao1602A-1609shi, baoshanqu ,
Shanghai 200.000 CN.

In die USA importiert: Sanven Technology Ltd. Suite 250, 9166 Anaheim
Place, Rancho Cucamonga, CA 91730

UK	REP
-----------	------------

YH CONSULTING LIMITED. C/O YH Consulting
Limited Office 147, Centurion House, London
Road, Staines-upon-Thames, Surrey, TW18 4AX

EC	REP
-----------	------------

E-CrossStu GmbH
Mainzer Landstr.69,
60329 Frankfurt am Main.



VEVOR

Affordable. Reliable. Home Improvement.

STOJAKI NA ROŚLINY

(Z LAMPĄ LED DO UPRAWY ROŚLIN : ZWLDT-02)



INSTRUKCJA OBSŁUGI

MODEL: SSPS-0 3 -USA \ SSPS-0 3 - UE

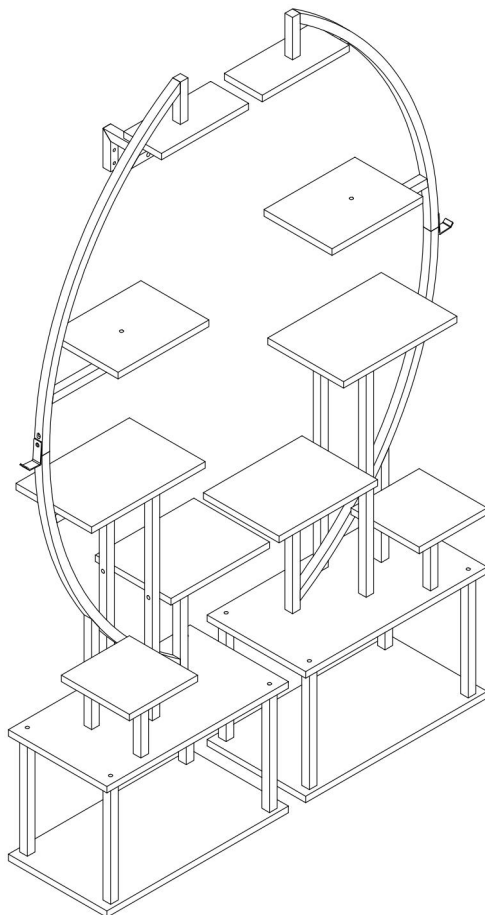
MODEL: SSPS-0 3 -USA \ SSPS-0 3 - UE



To jest oryginalna instrukcja obsługi. Przed użyciem prosimy o dokładne zapoznanie się z treścią instrukcji. Firma VEVOR zastrzega sobie prawo do jednoznacznej interpretacji niniejszej instrukcji obsługi. Wygląd produktu zależy od stanu, w jakim go otrzymali Państwo. Prosimy o wyrozumiałość, ale nie będziemy Państwa ponownie informować o aktualizacjach technologicznych lub oprogramowania naszego produktu.

	<p>Ostrzeżenie: Aby zminimalizować ryzyko obrażeń, użytkownik powinien uważnie przeczytać instrukcję obsługi.</p> <p>PRZED UŻYCIEM PRZECZYTAJ WSZYSTKIE INSTRUKCJE</p> <p>Należy przeczytać wszystkie instrukcje dotyczące bezpieczeństwa i obsługi, należy przestrzegać i stosować się do nich przed rozpoczęciem użytkowania urządzenia.</p>
	<p>To urządzenie jest zgodne z częścią 15 przepisów FCC. Jego działanie podlega następującym dwóm warunkom: (1) urządzenie nie może powodować szkodliwych zakłóceń oraz (2) urządzenie musi akceptować wszelkie odbierane zakłócenia, w tym zakłócenia, które mogą powodować niepożądane działanie.</p>

SAFETY INSTRUCTIONS

Dziękujemy za zakup naszych stojaków na rośliny .

- Przed użyciem produktu prosimy o uważne przeczytanie i przestrzeganie poniższych instrukcji. Instalując lub używając produktu, potwierdzasz, że uważnie przeczytałeś i zaakceptowałeś poniższe instrukcje bezpieczeństwa.
- Prosimy zachować instrukcję do wykorzystania w przyszłości.

Ważne uwagi:

- (1) Lampa do uprawy roślin jest przeznaczona wyłącznie do użytku wewnątrz pomieszczeń.
- (2) Lampa do uprawy roślin nie jest wodoodporna, nie należy jej zanurzać w wodzie.
- (3) Proszę odłączyć dopływ prądu podczas burzy.
- (4) Należy upewnić się, że produkt jest używany w normalnym środowisku pracy lampy. powinna być niższa niż +104 ° F i 80%RH.

Wytyczne bezpieczeństwa:

- Nieprzestrzeganie poniższych instrukcji może prowadzić do nieprawidłowego użytkowania produktu lub nieoczekiwanych strat. Zdecydowanie zalecamy ściśle przestrzeganie poniższych wytycznych.

- Produkt należy instalować i używać ściśle zgodnie z załączoną instrukcją. instrukcje.

PRODUCT DESCRIPTION

- Oświetlenie LED do uprawy roślin to doskonałe rozwiązanie w porównaniu z tradycyjnym oświetleniem do uprawy.
- Lampa do uprawy roślin ma wyższy PPFD, mniejsze zużycie energii i dłuższą żywotność.





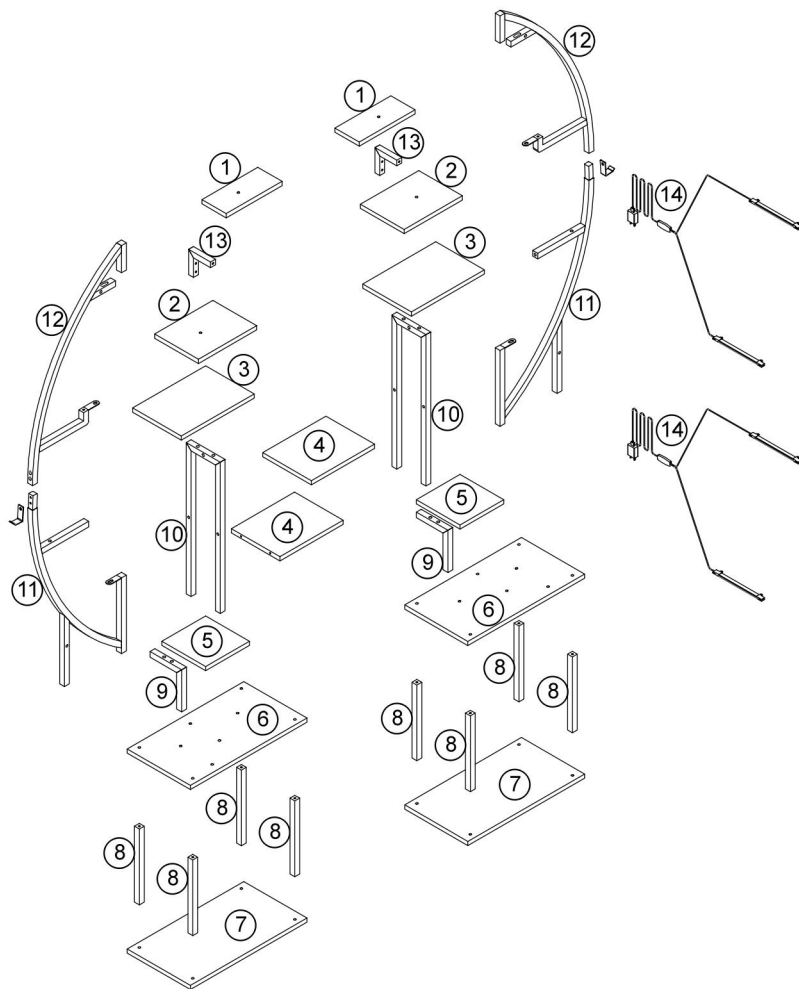

Model	SSPS-0 3 -US	SSPS-0 3 -UE
LAMPA LED DO UPRAWY	Z WLDT-02	
Dzielnica	Ameryka Północna	Europa
Napięcie adaptera	Prąd zmienny 110 V~120 V 60 Hz	Prąd zmienny 220 V~240 V 50 Hz
Moc światła	5~6 W (Pełne spektrum) / 2 światła	
Poziomy półek	7 poziomów	
Kolor	Brązowo-czarny	
Tworzywo	Metale i płyty wiórowe	

PARTS LIST

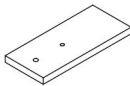
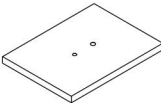
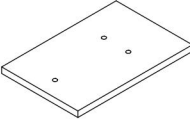
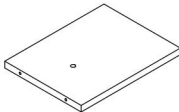
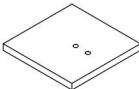
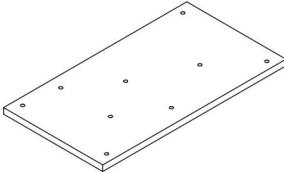
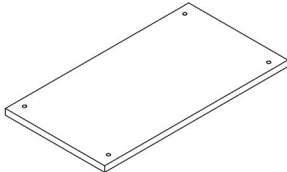

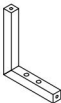
No.	PICTURE	SIZE	QTY	No.	PICTURE	SIZE	QTY
A		M6*10	8	G		S	2
B		M6*30	12	H			2
C		M6*35	18	I		ST5*40	4
D		M6*30	18				
E		ST7*40	4				
F		40*40*5	8				1

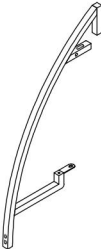
PARTS LIST

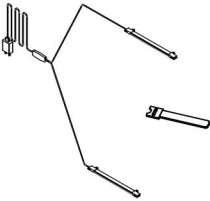
<p>1</p>  <p>X2</p>	<p>2</p>  <p>X2</p>	<p>3</p>  <p>X2</p>
<p>4</p>  <p>X2</p>	<p>5</p>  <p>X2</p>	<p>6</p>  <p>X2</p>
<p>7</p>  <p>X2</p>	<p>8</p>  <p>X8</p>	<p>9</p>  <p>X2</p>
<p>10</p>  <p>X2</p>	<p>11</p>  <p>X2</p>	<p>12</p>  <p>X2</p>
<p>13</p>  <p>X2</p>	<p>14</p>  <p>X2</p>	

ASSEMBLY INSTRUCTION

Matters needing attention

(1) When installing the screws in the installation step, the screws do not need to be tightened.

then tighten all the screws.

After this installation step is confirmed and the holes are aligned,

(2) If the screws are tightened during the installation process, it will cause problems such as misalignment of the screw holes and misalignment of the board in subsequent installations.

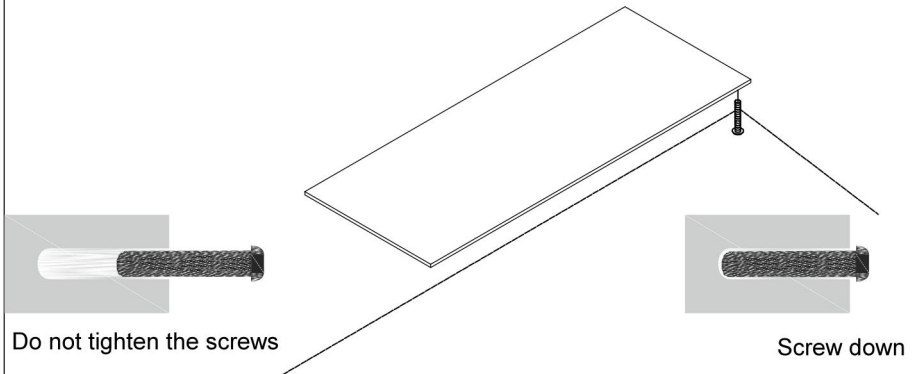

If you encounter any problems during the installation or use you can contact us at any time, we will resolve your issue within 24 hours

ASSEMBLY INSTRUCTION

STEP 1

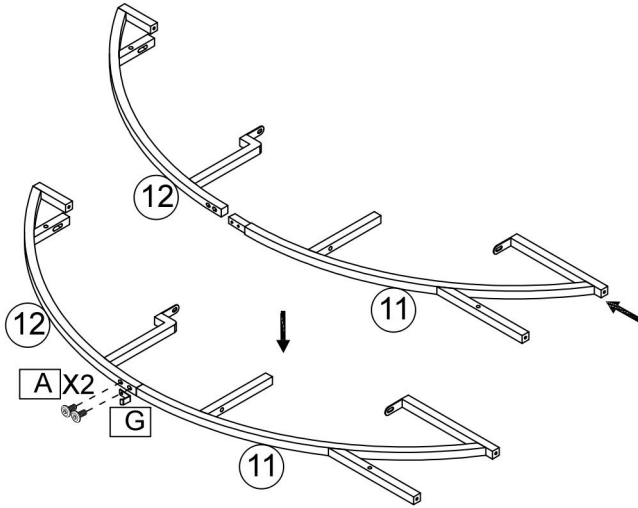

X2

A M6*10mm  X4	G  X2
--	--

STEP 2

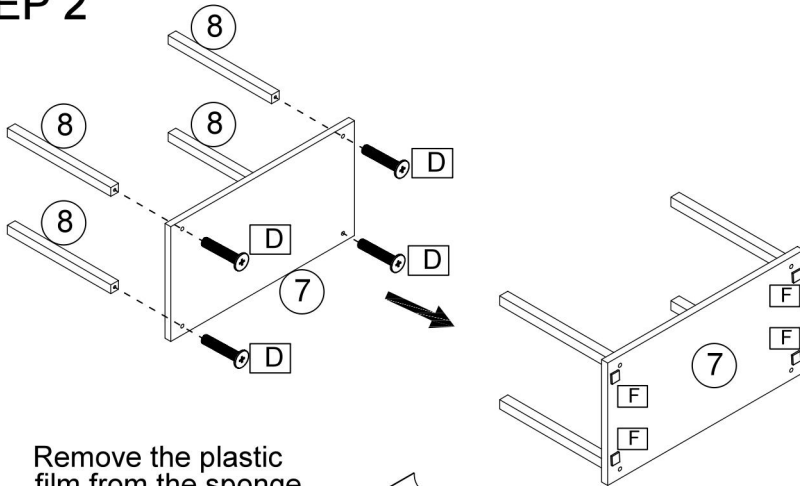

Remove the plastic film from the sponge pad before installation 

X2

D M6*30mm  X8	F 40*40*5mm  X8
--	--

ASSEMBLY INSTRUCTION

STEP 3

Please note that the left and right wooden boards can be interchanged, just flip the 6th board over.

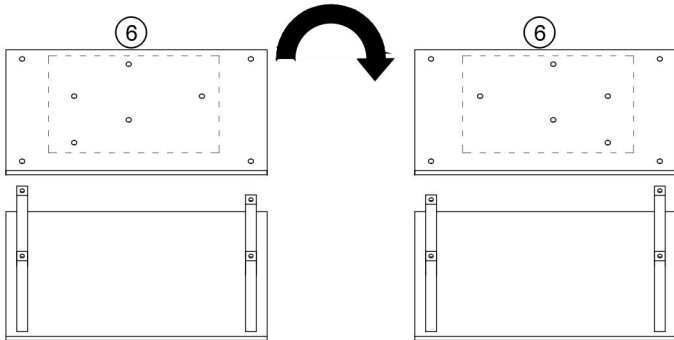

Note the direction of the hole in Board No. 6. The Hole in the left picture represents the left side, and the hole in the right picture represents the right side when the board No. 6 is reversed.

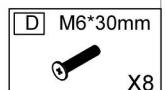
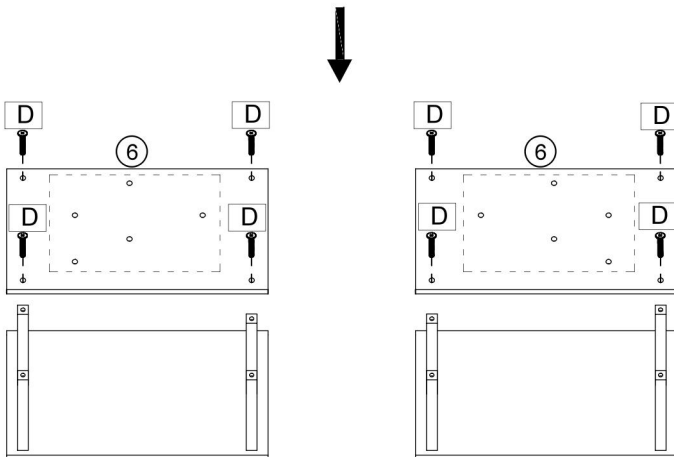

ASSEMBLY INSTRUCTION

STEP 4

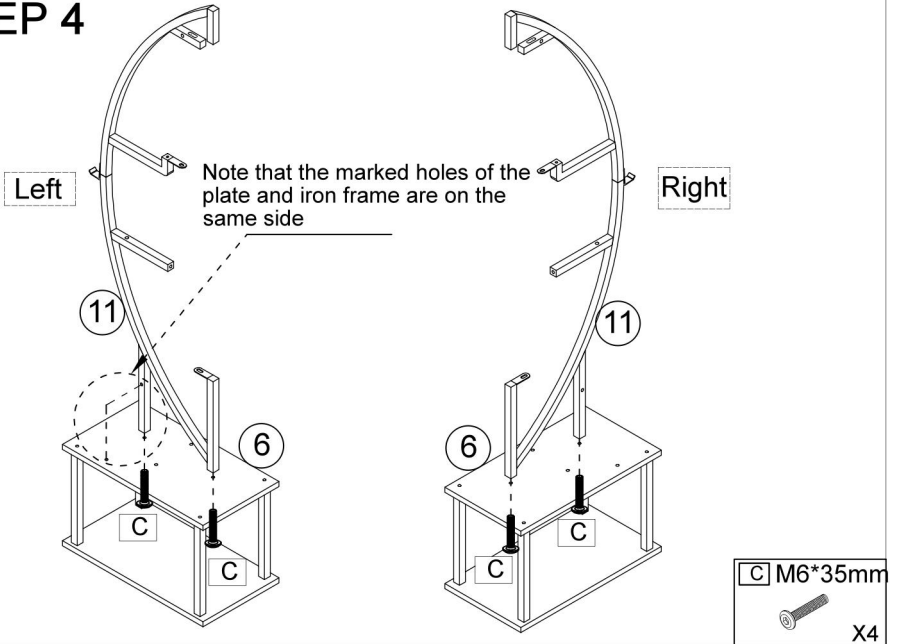

STEP 5

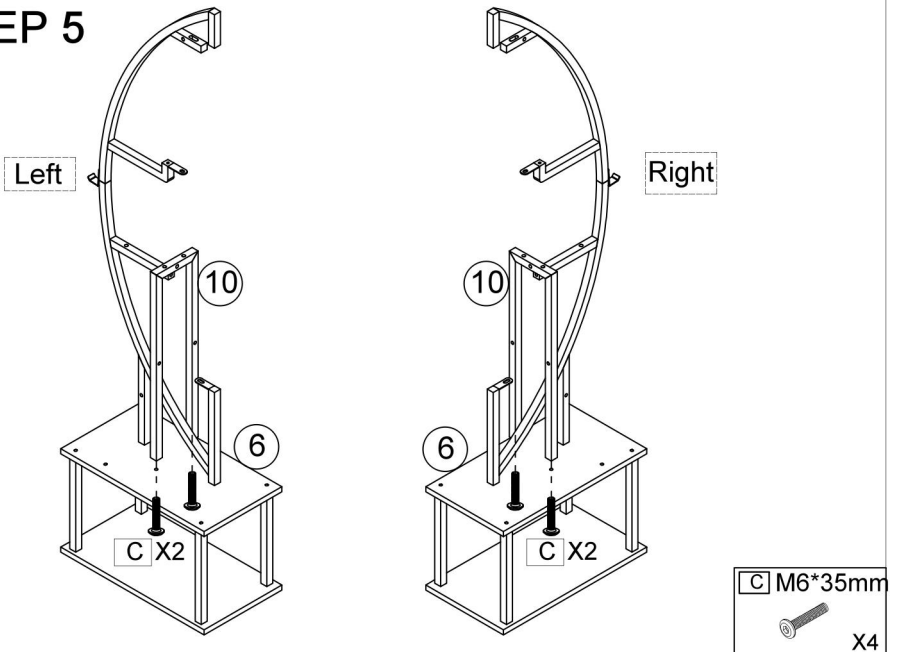

ASSEMBLY INSTRUCTION

STEP 6

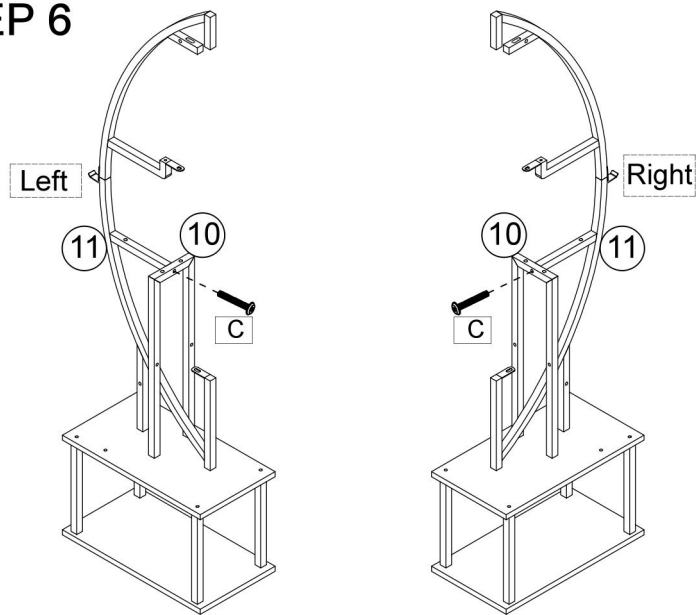

STEP 7

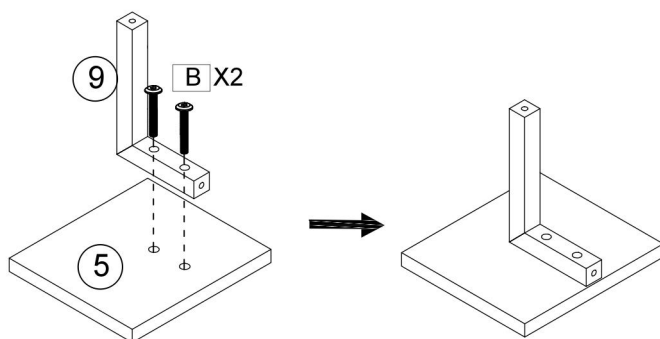

X2

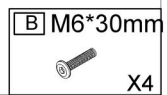

ASSEMBLY INSTRUCTION

STEP 8

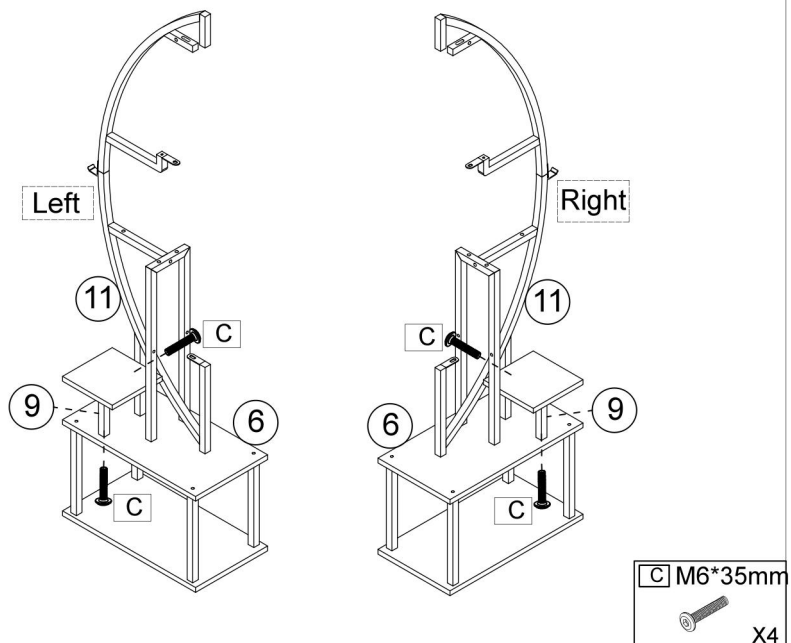

STEP 9

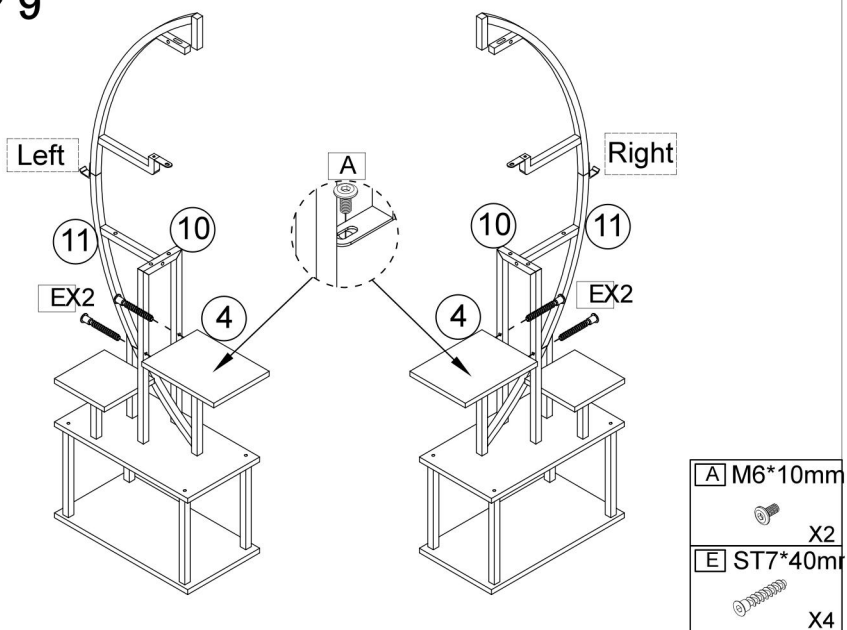

ASSEMBLY INSTRUCTION

STEP 10

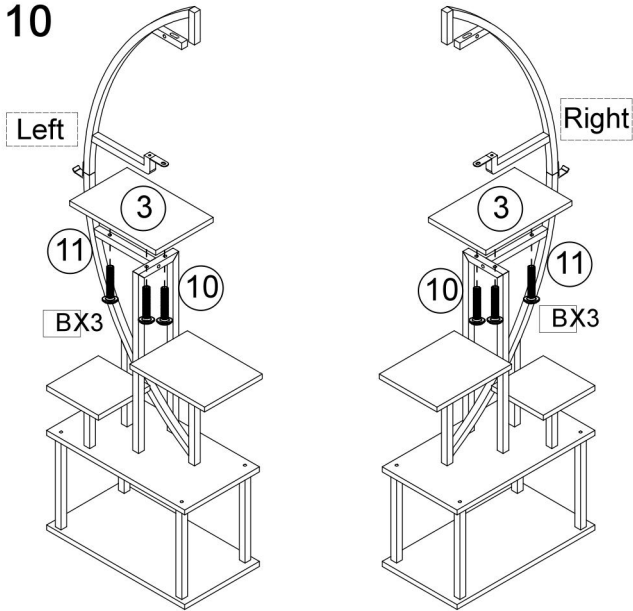

B | M6*30mm
X6

STEP 11

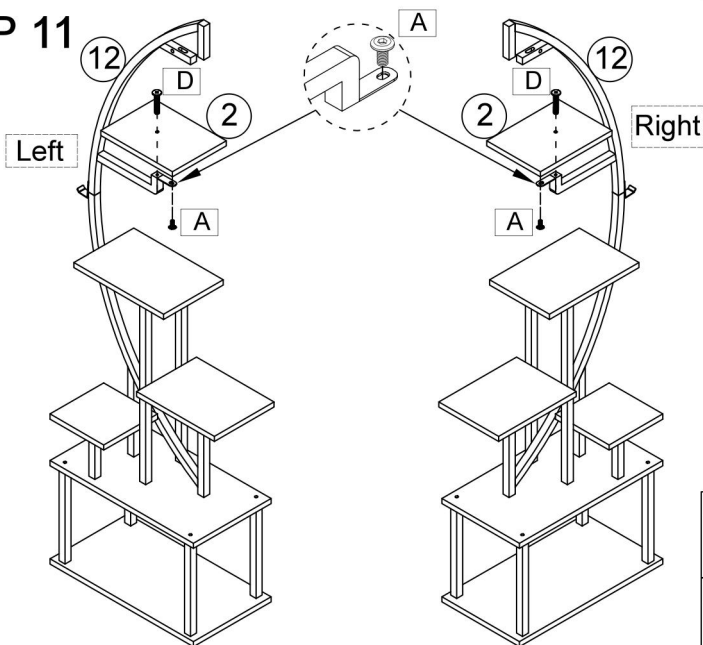



A | M6*10mm
X2
D | M6*30mm
X2

ASSEMBLY INSTRUCTION

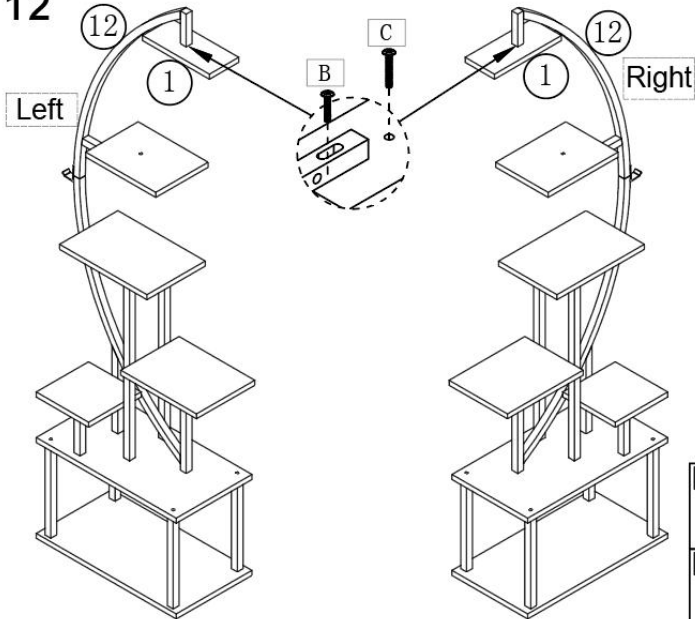
STEP 12



B	M6*30mm
	X2
C	M6*35mm
	X2

STEP 13

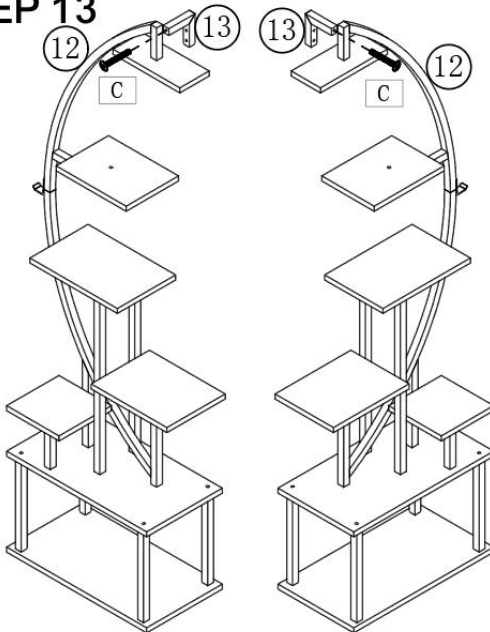



13



H

Anti-tilt



Note that you can choose an anti-tilt rack or fixing belt according to your needs.

If you select a fixed belt, please refer to steps 15-16

13		X2
C	M6*35mm	X2

ASSEMBLY INSTRUCTION

STEP 14

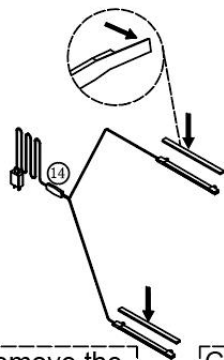

Carefully remove the plastic film behind the light strip

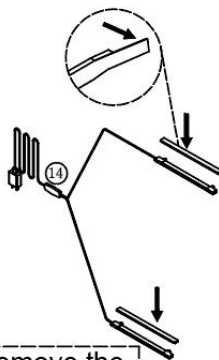

Carefully remove the plastic film behind the light strip

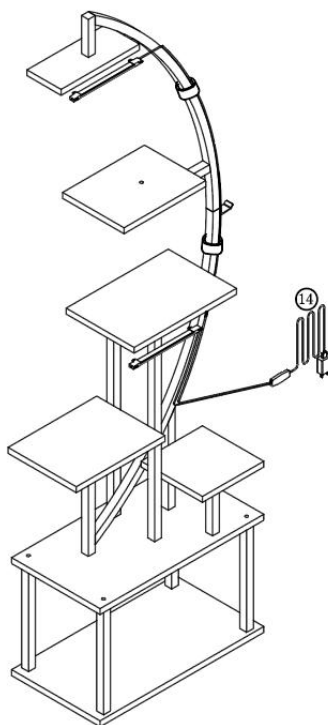
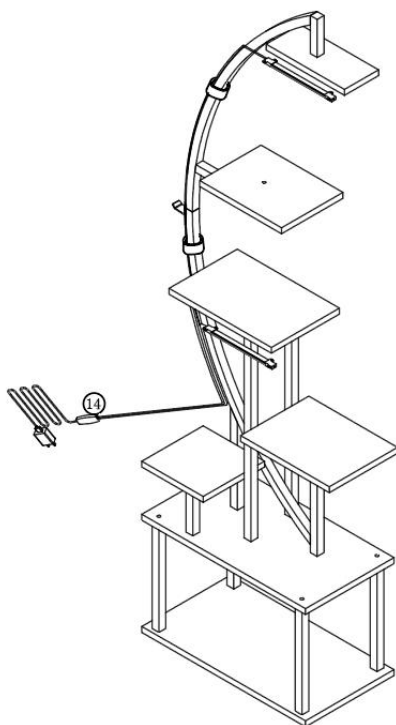

ASSEMBLY INSTRUCTION

STEP 15

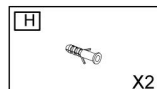
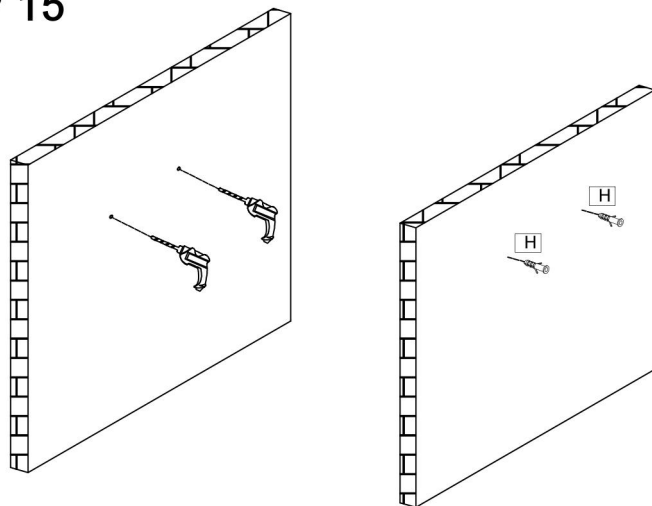

STEP 16

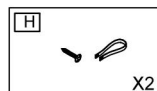
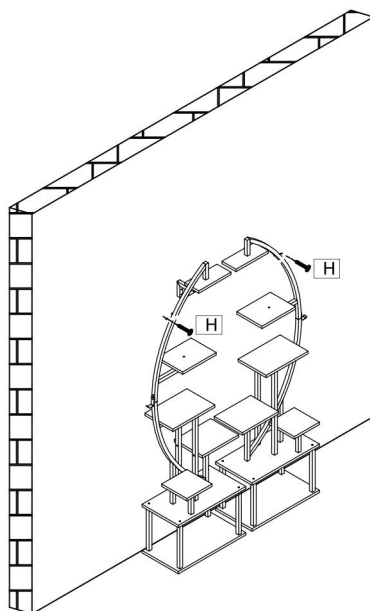

ASSEMBLY INSTRUCTION

STEP 17

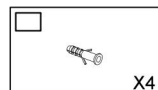
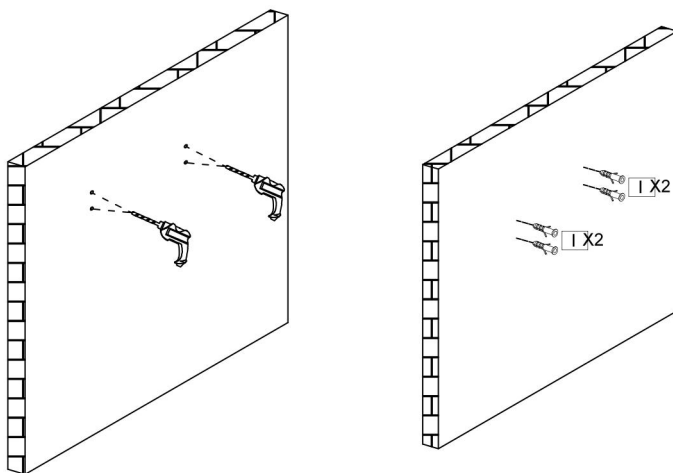

STEP 18

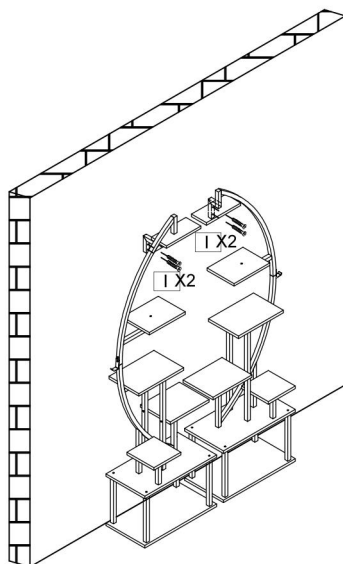

FCC INFORMATION

OSTRZEŻENIA: Zmiany lub modyfikacje, które nie zostały wyraźnie zatwierdzone przez stronę odpowiedzialną za nieprzestrzeganie tych zasad może spowodować unieważnienie prawa użytkownika do korzystania ze sprzętu!

To urządzenie jest zgodne z częścią 15 przepisów FCC. Jego eksploatacja podlega następującym zasadom dwa warunki:

- 1) Ten produkt może powodować szkodliwe zakłócenia.
- 2) Ten produkt musi akceptować wszelkie odbierane zakłócenia, w tym zakłócenia, które mogą spowodować niepożądane działanie.

OSTRZEŻENIE: Zmiany lub modyfikacje, które nie zostały wyraźnie zatwierdzone przez stronę odpowiedzialną za zgodność, mogą spowodować unieważnienie prawa użytkownika do korzystania ze sprzętu.

UWAGA: To urządzenie zostało przetestowane i uznane za zgodne z ograniczeniami dla urządzeń cyfrowych klasy B, zgodnie z częścią 15 przepisów FCC. Ograniczenia te mają na celu zapewnienie odpowiedniej ochrony przed szkodliwymi zakłóceniami w instalacjach domowych. To urządzenie generuje, wykorzystuje i może emitować energię o częstotliwości radiowej, a jeśli nie zostanie zainstalowane i użytkowane zgodnie z instrukcją, może powodować szkodliwe zakłócenia w komunikacji radiowej. Nie ma jednak gwarancji, że zakłócenia nie wystąpią w danej instalacji. Jeśli to urządzenie powoduje szkodliwe zakłócenia w odbiorze sygnału radiowego lub telewizyjnego, można podjąć jeden lub więcej z następujących kroków:

- Zmiana orientacji lub położenia anteny odbiorczej.
- Zwiększ odległość między urządzeniem i odbiornikiem.
- Podłącz urządzenie do gniazdka w innym obwodzie niż ten, do którego podłączony jest odbiornik.
- Aby uzyskać pomoc, skontaktuj się ze sprzedawcą lub doświadczonym technikiem radiowo-telewizyjnym.

Producent: Shanghaimuxinmuyeyouxiangongsi

Adres: Shuangchenglu 803nong11hao1602A-1609shi, baoshanqu ,
szanghaj 200000 CN.

Importowane do USA: Sanven Technology Ltd. Suite 250, 9166 Anaheim
Miejsce, Rancho Cucamonga, CA 91730

UK	REP
-----------	------------

YH CONSULTING LIMITED. C/O YH Consulting
Limited Office 147, Centurion House, London
Road, Staines-upon-Thames, Surrey, TW18 4AX

EC	REP
-----------	------------

E-CrossStu GmbH
Mainzer Landstr.69,
60329 Frankfurt am Main.



VEVOR

Affordable. Reliable. Home Improvement.



PLANTENSTANDAARDS
(MET LED-KWEEKLAMP : ZWLDT-02)
GEBRUIKERSHANDLEIDING

MODEL: SSPS-0 3 -VS \ SSPS- 0 3 -EU

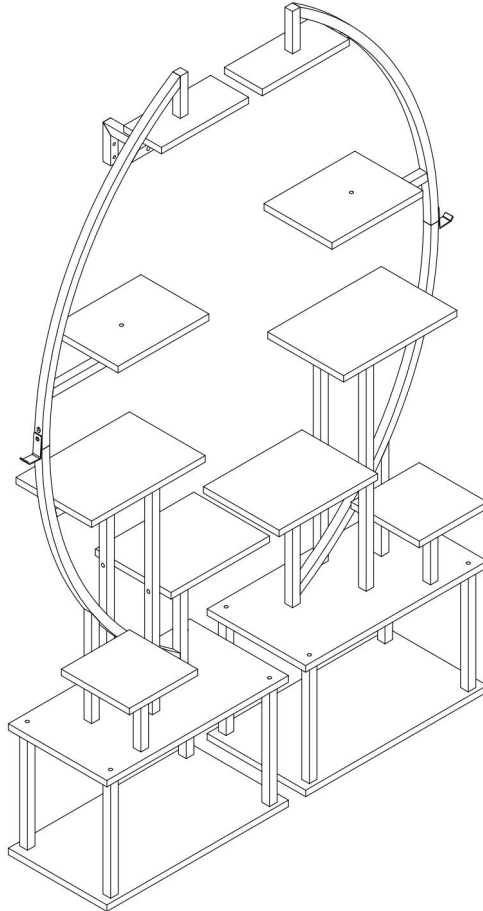
MODEL: SSPS-0 3 -VS \ SSPS- 0 3 -EU



Dit is de originele handleiding. Lees alle instructies zorgvuldig door voordat u het product gebruikt. VEVOR behoudt zich het recht voor om de gebruiksaanwijzing duidelijk te interpreteren. Het uiterlijk van het product is afhankelijk van het product dat u hebt ontvangen. Neemt u het ons niet kwalijk dat we u niet meer op de hoogte stellen van eventuele technologische of software-updates voor ons product.

	<p>Waarschuwing: om het risico op letsel te verminderen, dient de gebruiker de gebruiksaanwijzing zorgvuldig te lezen.</p> <p>LEES ALLE INSTRUCTIES VÓÓR GEBRUIK</p> <p>Alle veiligheids- en bedieningsinstructies dienen gelezen te worden, worden nageleefd en opgevolgd voordat de eenheid in werking wordt gesteld.</p>
	<p>Dit apparaat voldoet aan Deel 15 van de FCC-regels. Het gebruik is onderworpen aan de volgende twee voorwaarden: (1) Dit apparaat mag geen schadelijke interferentie veroorzaken, en (2) dit apparaat moet alle ontvangen interferentie accepteren, inclusief interferentie die ongewenste werking kan veroorzaken.</p>

SAFETY INSTRUCTIONS

Hartelijk dank voor uw aankoop van onze plantenstandaards .

- Voordat u het product gebruikt, verzoeken wij u de onderstaande instructies zorgvuldig te lezen en op te volgen. Door het product te installeren of te gebruiken, bevestigt u dat u de volgende veiligheidsinstructies zorgvuldig hebt gelezen en geaccepteerd.
- Zorg ervoor dat u deze handleiding bewaart voor toekomstig gebruik.

Belangrijke opmerkingen:

- (1) De kweeklamp is uitsluitend bedoeld voor gebruik binnenshuis.
- (2) De kweeklamp is niet waterdicht. Laat de kweeklamp daarom niet in water weken.
- (3) Schakel de stroom uit als het onweert.
- (4) Zorg ervoor dat het product in een normale omgeving wordt gebruikt. De werkomgeving van de lamp moet lager zijn dan +104 ° F en 80%RV.

Veiligheidsrichtlijnen:

- Overtreding van de volgende instructies kan leiden tot abnormaal gebruik van het product of onverwachte verliezen. Wij raden u ten zeerste aan de volgende richtlijnen strikt te volgen.
- Installeer en gebruik het product strikt in overeenstemming met de

meegeleverde instructies.

PRODUCT DESCRIPTION

- Led-kweeklampen zijn een uitstekende optie voor het kweken van planten, vergeleken met traditionele kweeklampen.
- Kweeklampen hebben een hogere PPF, een lager stroomverbruik en een langere levensduur.





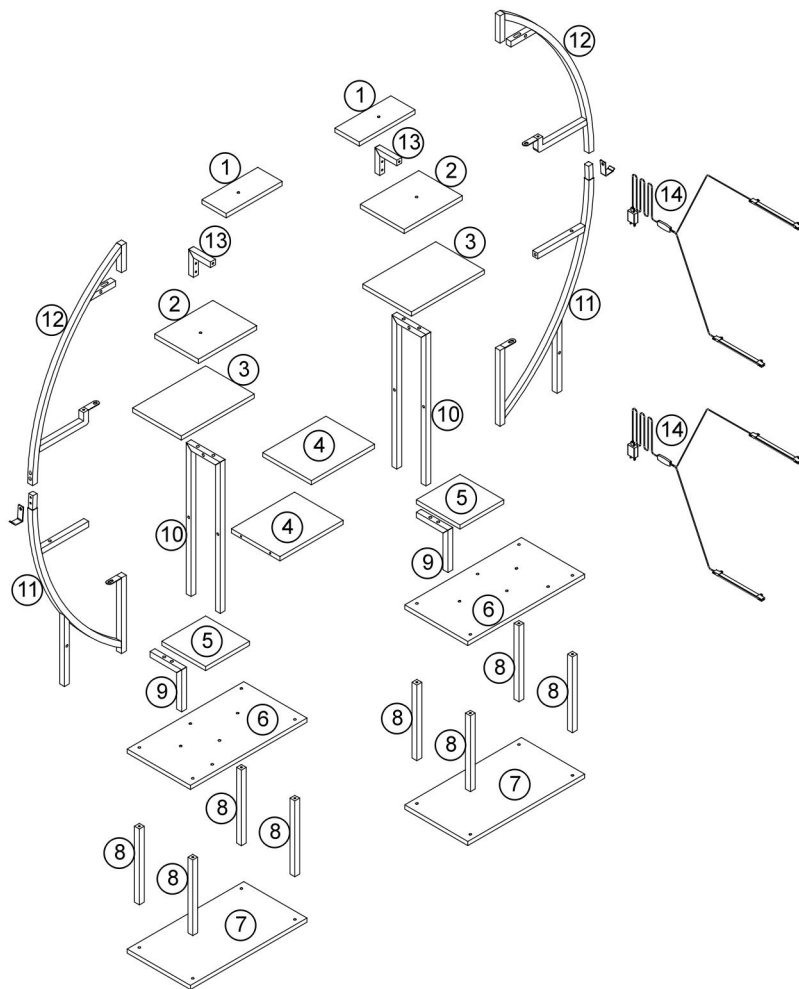

Model	SSPS-0 3 -VS	SSPS-0 3 -EU
LED-GROEILAMP	Z WLDT-02	
Wijk	Noord-Amerika	Europa
Adapterspanning	Wisselstroom 110V~120V 60Hz	Wisselstroom 220V~240V 50Hz
Lichtkracht	5~6 Watt (Volledig spectrum) / 2 lampen	
Plankniveaus	7 niveaus	
Kleur	Bruin & Zwart	
Materiaal	Metalen & Spaanplaat	

PARTS LIST

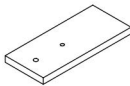
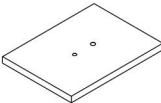
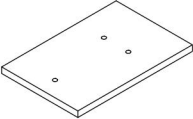
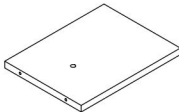
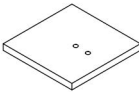
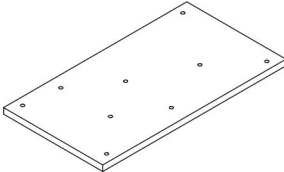
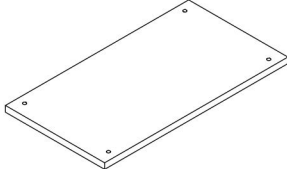

No.	PICTURE	SIZE	QTY	No.	PICTURE	SIZE	QTY
A		M6*10	8	G		S	2
B		M6*30	12	H			2
C		M6*35	18	I		ST5*40	4
D		M6*30	18				
E		ST7*40	4				
F		40*40*5	8				1

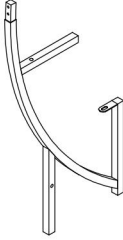
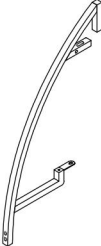
PARTS LIST

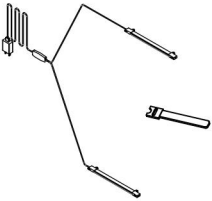
<p>1</p>  <p>X2</p>	<p>2</p>  <p>X2</p>	<p>3</p>  <p>X2</p>
<p>4</p>  <p>X2</p>	<p>5</p>  <p>X2</p>	<p>6</p>  <p>X2</p>
<p>7</p>  <p>X2</p>	<p>8</p>  <p>X8</p>	<p>9</p>  <p>X2</p>
<p>10</p>  <p>X2</p>	<p>11</p>  <p>X2</p>	<p>12</p>  <p>X2</p>
<p>13</p>  <p>X2</p>	<p>14</p>  <p>X2</p>	

ASSEMBLY INSTRUCTION

Matters needing attention

(1) When installing the screws in the installation step, the screws do not need to be tightened.

then tighten all the screws.

After this installation step is confirmed and the holes are aligned,

(2) If the screws are tightened during the installation process, it will cause problems such as misalignment of the screw holes and misalignment of the board in subsequent installations.

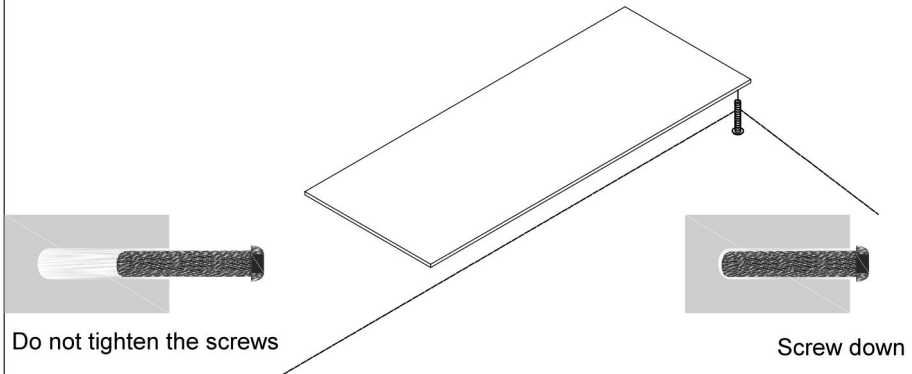

If you encounter any problems during the installation or use you can contact us at any time, we will resolve your issue within 24 hours

ASSEMBLY INSTRUCTION

STEP 1

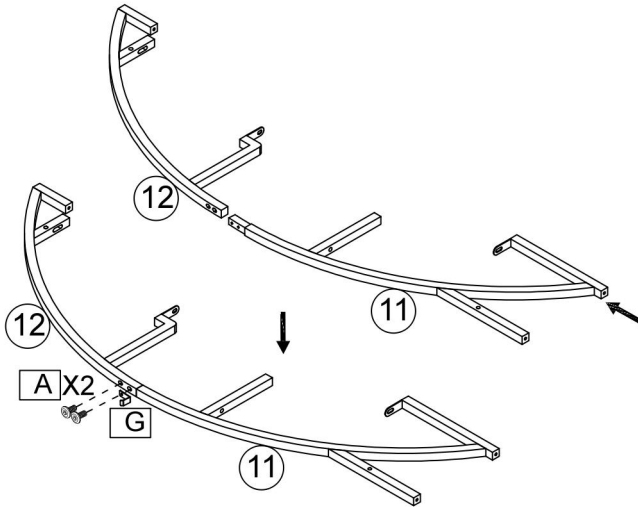

X2

A M6*10mm	G
	
X4	X2

STEP 2

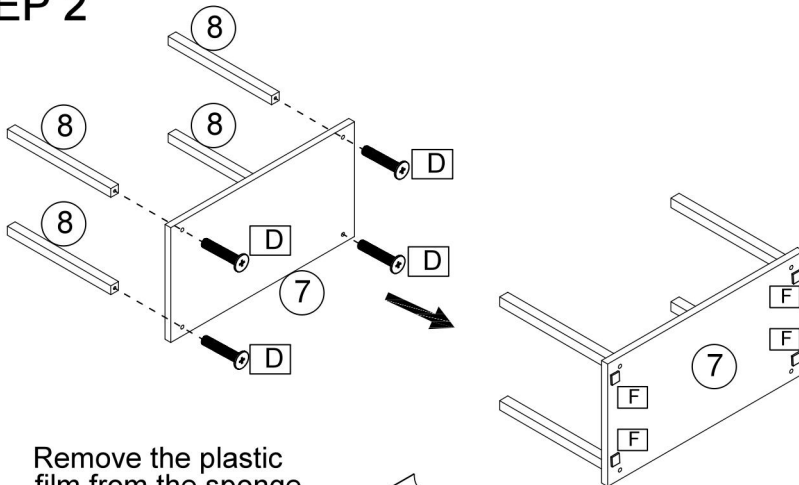

Remove the plastic film from the sponge pad before installation

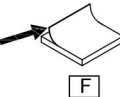

X2

D M6*30mm	F 40*40*5mm
	
X8	X8

ASSEMBLY INSTRUCTION

STEP 3

Please note that the left and right wooden boards can be interchanged, just flip the 6th board over.

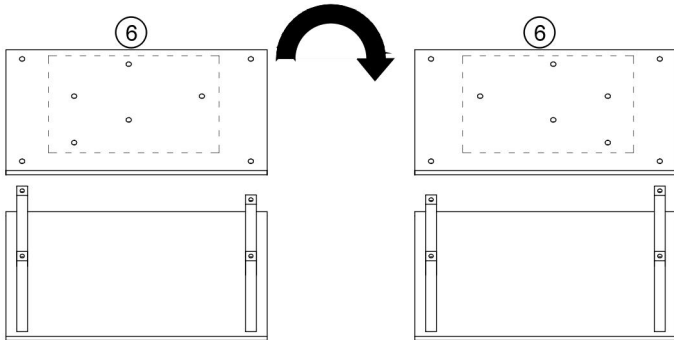

Note the direction of the hole in Board No. 6. The Hole in the left picture represents the left side, and the hole in the right picture represents the right side when the board No. 6 is reversed.

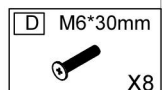
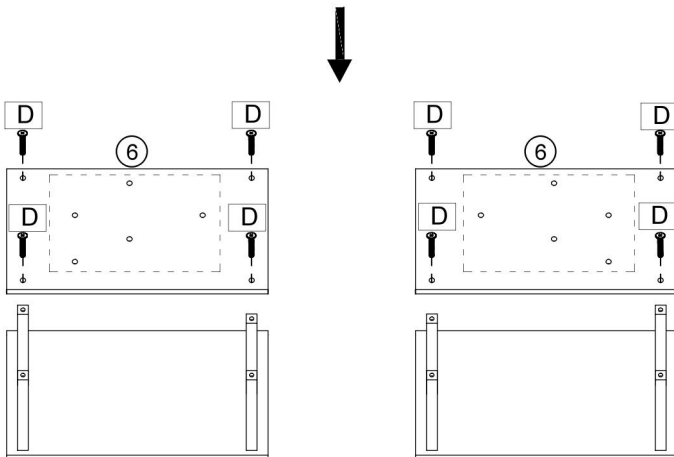

ASSEMBLY INSTRUCTION

STEP 4

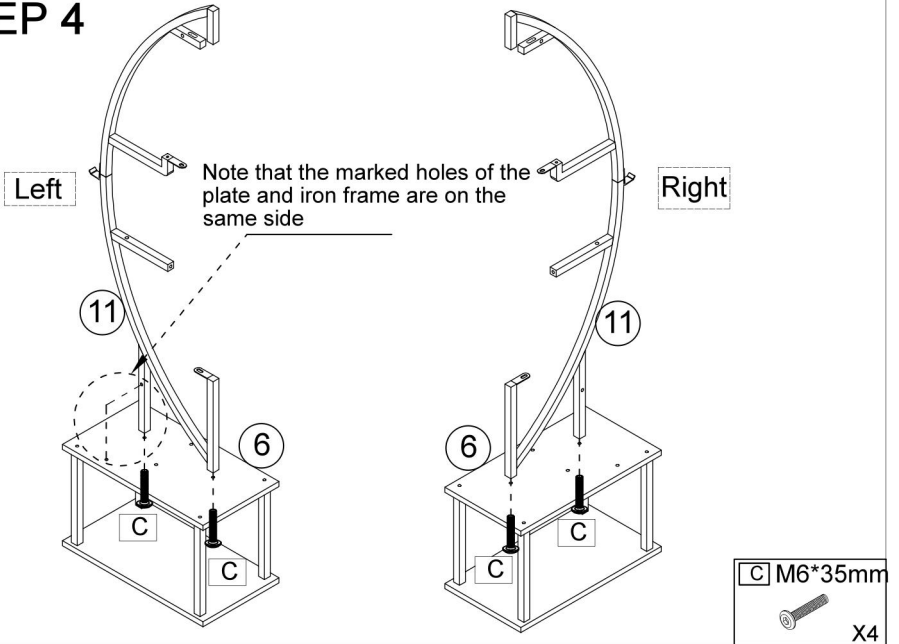

STEP 5

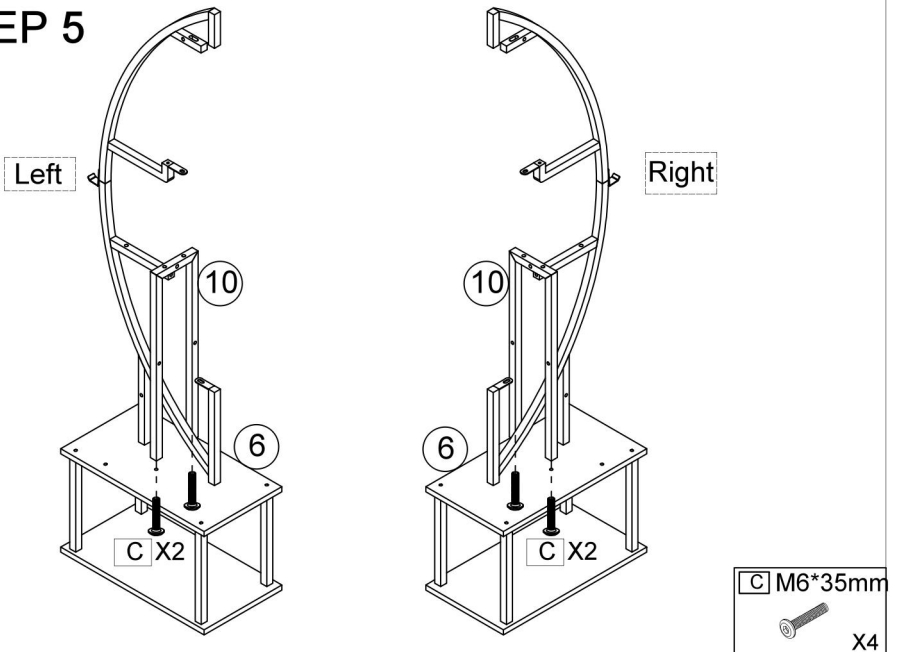

ASSEMBLY INSTRUCTION

STEP 6

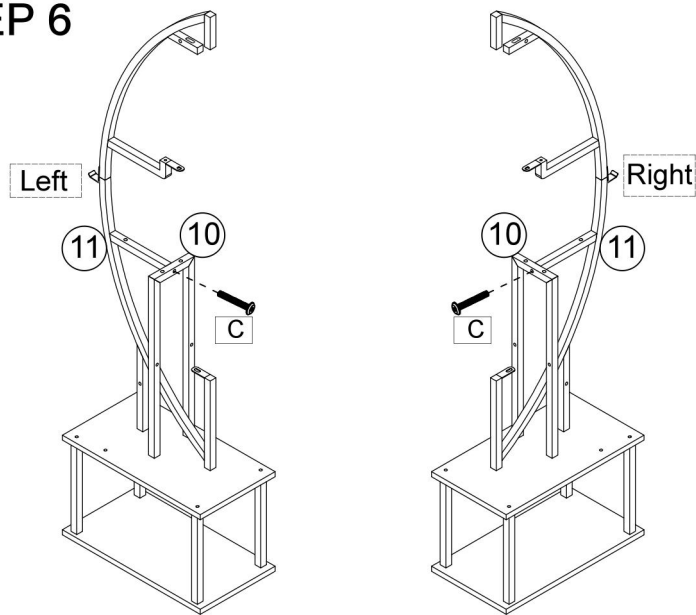

STEP 7

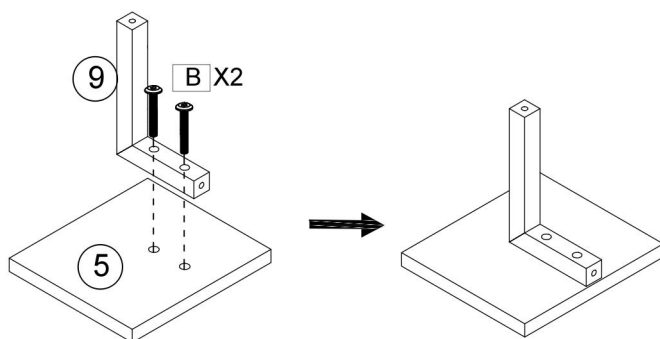

X2

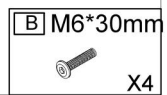

ASSEMBLY INSTRUCTION

STEP 8

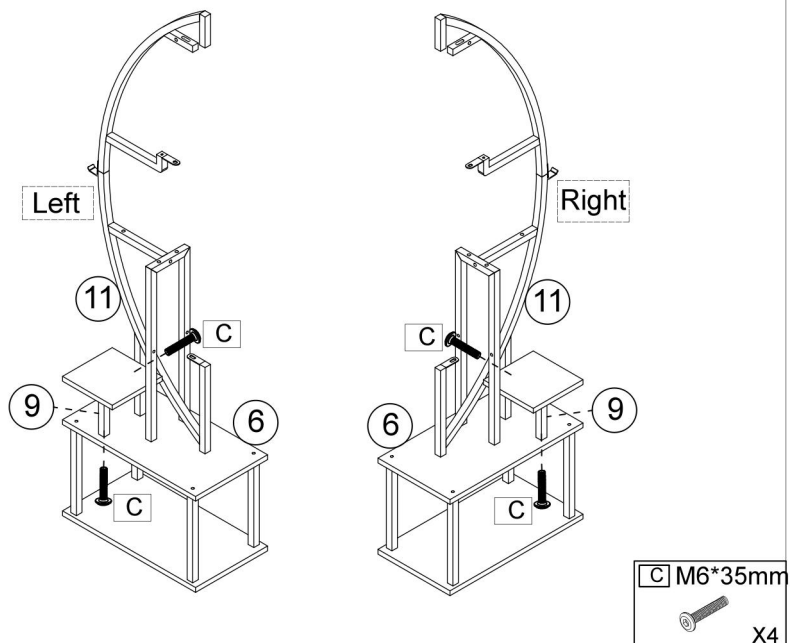

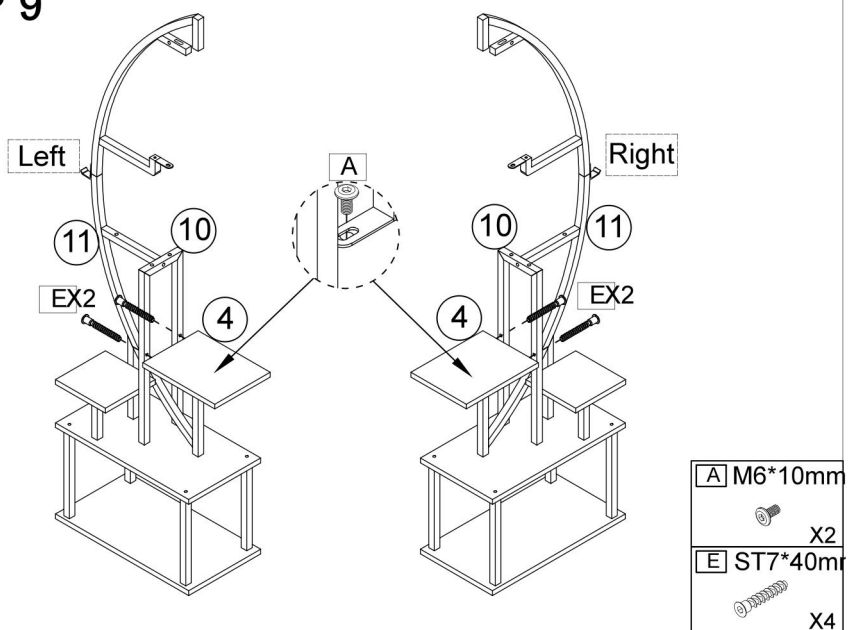

STEP 9

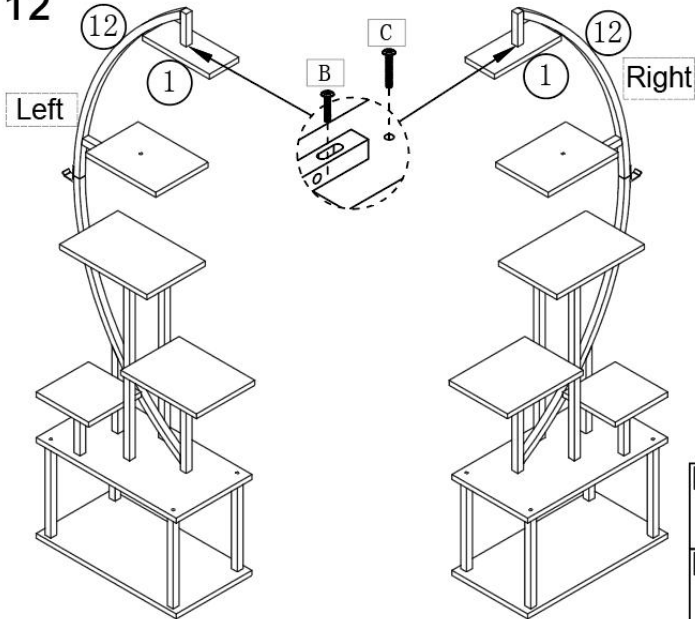

ASSEMBLY INSTRUCTION

STEP 12



B	M6*30mm
	X2
C	M6*35mm
	X2

STEP 13

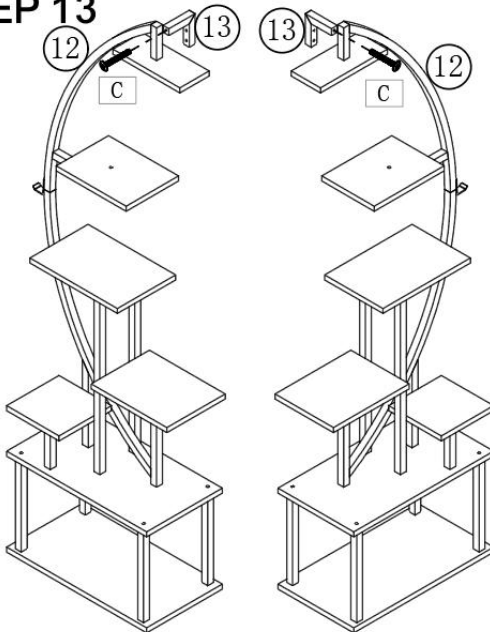



13



H

Anti-tilt



Note that you can choose an anti-tilt rack or fixing belt according to your needs.

If you select a fixed belt, please refer to steps 15-16

13		X2
C	M6*35mm	X2

ASSEMBLY INSTRUCTION

STEP 14

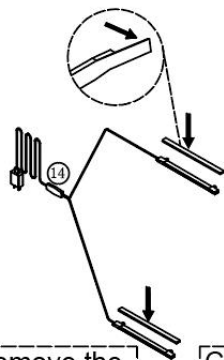

Carefully remove the plastic film behind the light strip

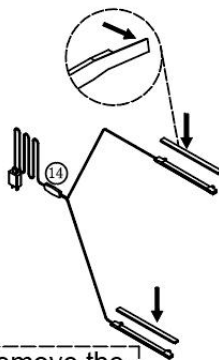

Carefully remove the plastic film behind the light strip

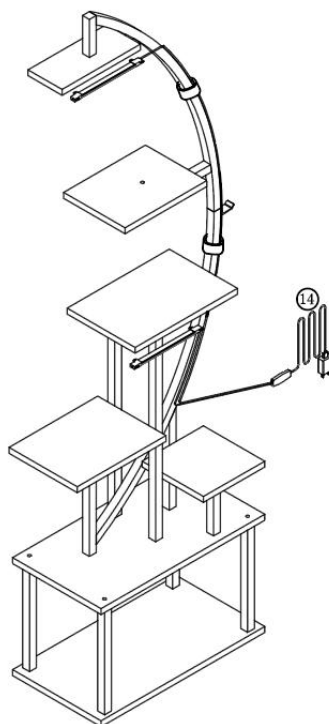
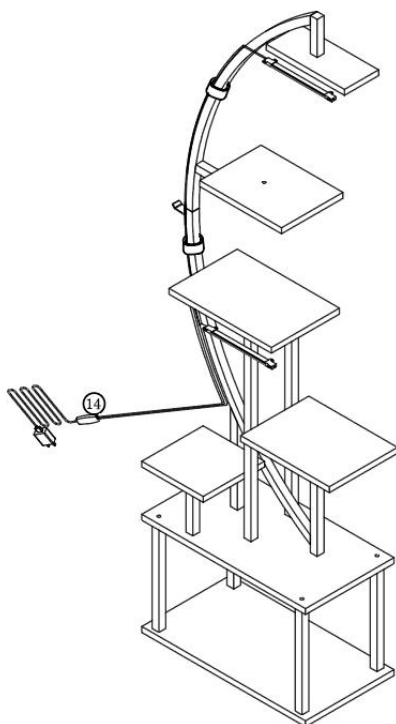

ASSEMBLY INSTRUCTION

STEP 15

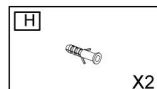
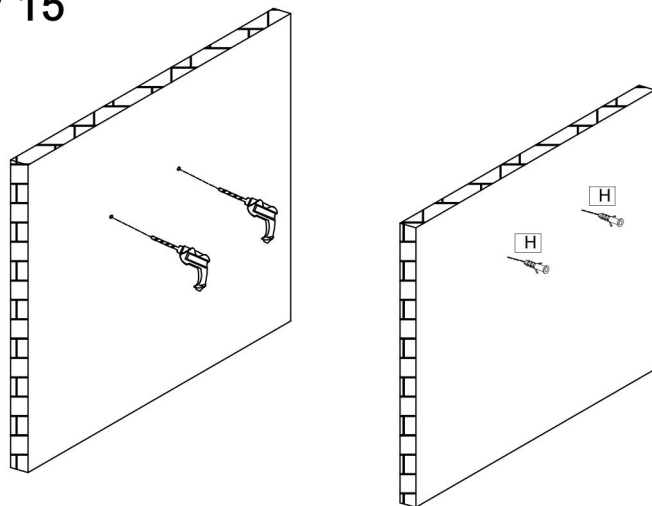

STEP 16

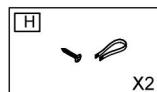
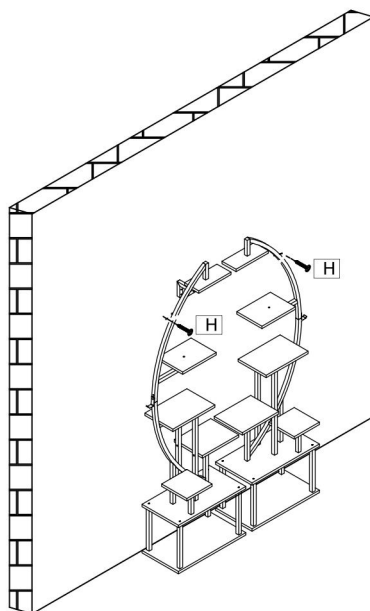

ASSEMBLY INSTRUCTION

STEP 17

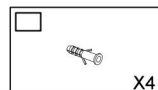
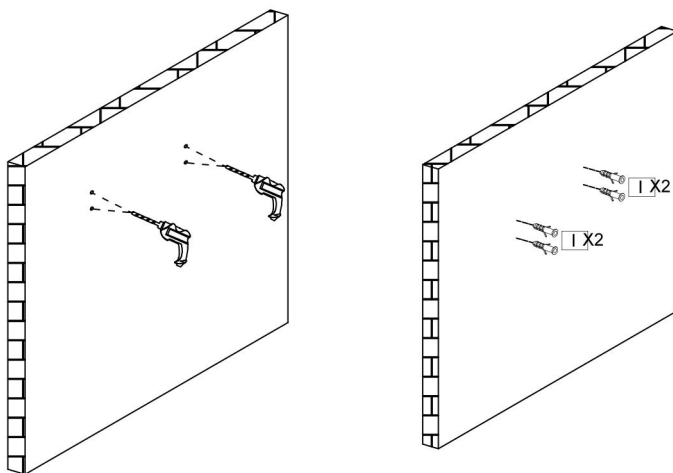

STEP 18

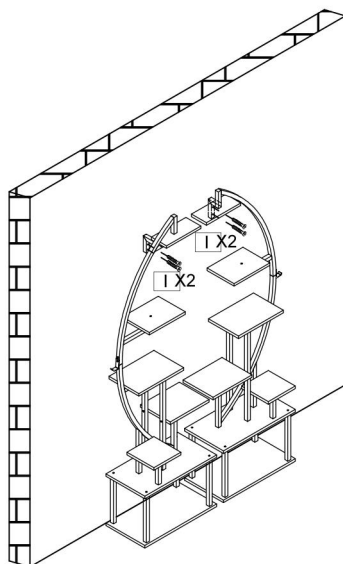

FCC INFORMATION

WAARSCHUWINGEN: Wijzigingen of aanpassingen die niet uitdrukkelijk zijn goedgekeurd door de partij die verantwoordelijk is voor Het niet naleven van deze instructies kan de bevoegdheid van de gebruiker om het apparaat te bedienen ongeldig maken!

Dit apparaat voldoet aan Deel 15 van de FCC-regels. De werking is onderworpen aan de volgende voorwaarden: twee voorwaarden:

- 1) Dit product kan schadelijke interferentie veroorzaken.
- 2) Dit product moet alle ontvangen interferentie accepteren, inclusief interferentie die kan optreden ongewenste werking veroorzaken.

WAARSCHUWING: Wijzigingen of aanpassingen die niet uitdrukkelijk zijn goedgekeurd door de partij die verantwoordelijk is voor de naleving, kunnen de bevoegdheid van de gebruiker om het apparaat te bedienen ongeldig maken.

OPMERKING: Deze apparatuur is getest en voldoet aan de limieten voor een digitaal apparaat van klasse B, conform Deel 15 van de FCC-regels. Deze limieten zijn bedoeld om een redelijke bescherming te bieden tegen schadelijke interferentie in een woonomgeving. Dit apparaat genereert, gebruikt en kan radiofrequentie-energie uitstralen en kan, indien niet geïnstalleerd en gebruikt volgens de instructies, schadelijke interferentie in radiocommunicatie veroorzaken. Er is echter geen garantie dat er in een bepaalde installatie geen interferentie zal optreden. Als dit apparaat schadelijke interferentie in radio- of televisieontvangst veroorzaakt, kunt u een of meer van de volgende maatregelen nemen:

- Heroriënteer of verplaats de ontvangstantenne.
- Vergroot de afstand tussen de apparatuur en de ontvanger.
- Sluit het apparaat aan op een stopcontact in een ander circuit dan waarop de ontvanger is aangesloten.
- Raadpleeg de dealer of een ervaren radio-/tv-technicus voor hulp.

Fabrikant: Shanghaimuxinmuyeyouxiangongsi

Adres: Shuangchenglu 803nong11hao1602A-1609shi, baoshanqu ,
shanghai 200000 CN.

Geïmporteerd naar de VS: Sanven Technology Ltd. Suite 250, 9166
Anaheim

Plaats, Rancho Cucamonga, CA 91730

UK	REP
-----------	------------

YH CONSULTING LIMITED. C/O YH Consulting
Limited Office 147, Centurion House, London
Road, Staines-upon-Thames, Surrey, TW18 4AX

EC	REP
-----------	------------

E-CrossStu GmbH
Mainzer Landstr.69,
60329 Frankfurt am Main.



VEVOR

Affordable. Reliable. Home Improvement.

SOPORTES PARA PLANTAS

(CON LUZ LED DE CULTIVO : ZWLDT-02)



MANUAL DEL USUARIO

MODELO: SSPS-0 3 - EE . UU. \ SSPS-0 3 - UE

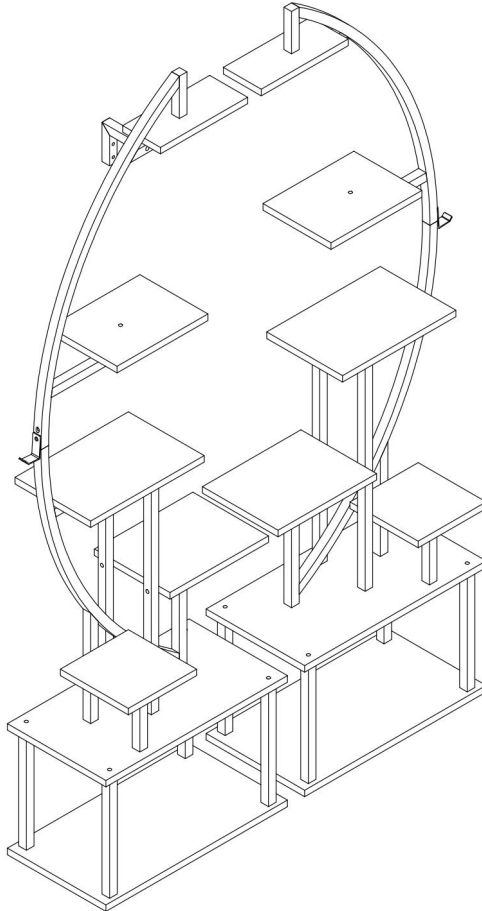
MODELO: SSPS-0 3 - EE . UU. \ SSPS-0 3 - UE



Estas son las instrucciones originales; lea atentamente todas las instrucciones del manual antes de utilizarlo. VEVOR se reserva el derecho de interpretar su manual de usuario. La apariencia del producto dependerá del producto que haya recibido. Le rogamos que nos disculpe si no le informamos de nuevo si hay actualizaciones tecnológicas o de software en nuestro producto.

	<p>Advertencia: Para reducir el riesgo de lesiones, el usuario debe leer atentamente el manual de instrucciones.</p> <p>LEA TODAS LAS INSTRUCCIONES ANTES DE USAR</p> <p>Se deben leer todas las instrucciones de seguridad y funcionamiento adheridos y seguidos antes de operar la unidad.</p>
	<p>Este dispositivo cumple con la Parte 15 de las Normas de la FCC. Su funcionamiento está sujeto a las dos condiciones siguientes: (1) Este dispositivo no puede causar interferencias perjudiciales y (2) este dispositivo debe aceptar cualquier interferencia recibida, incluidas las que puedan causar un funcionamiento no deseado.</p>

SAFETY INSTRUCTIONS

Gracias por adquirir nuestros soportes para plantas .

- Antes de usar el producto, le rogamos que lea atentamente y siga las instrucciones que se proporcionan a continuación. Al instalar o usar el producto, usted reconoce haber leído atentamente y aceptado las siguientes instrucciones de seguridad.
- Asegúrese de conservar este manual para futuras consultas.

Notas importantes:

- (1) La luz de cultivo es solo para uso en interiores.
- (2) La luz de cultivo no es resistente al agua, no dejes que la luz de cultivo se sumerja en agua.
- (3) Por favor, desconecte la energía cuando haya truenos.
- (4) Asegúrese de que el producto se utilice en un entorno normal. El entorno de funcionamiento de la lámpara... Debe ser inferior a +104 ° F y 80 % de humedad relativa.

Pautas de seguridad:

- El incumplimiento de las siguientes instrucciones puede provocar un uso inadecuado del producto o pérdidas inesperadas. Le recomendamos encarecidamente que siga estrictamente las siguientes directrices.
- Instale y utilice el producto estrictamente de acuerdo con las instrucciones proporcionadas. instrucciones.

PRODUCT DESCRIPTION

- La luz LED de cultivo es una excelente opción para el cultivo de plantas, en comparación con las luces de cultivo tradicionales.
- La luz de cultivo tiene un PPFD más alto, un menor consumo de energía y una vida útil más larga.





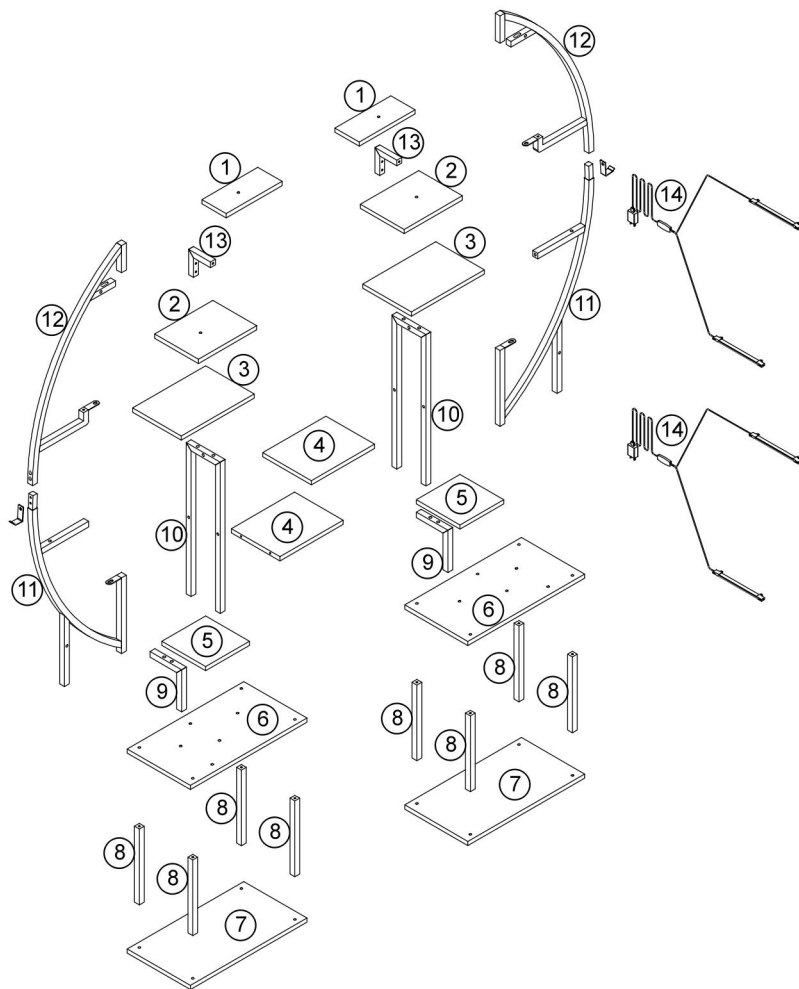

Modelo	SSPS-0 3 -EE. UU.	SSPS-0 3 -UE
LUZ LED DE CRECIMIENTO	Z WLDT-02	
Distrito	América del norte	Europa
Voltaje del adaptador	CA 110 V ~ 120 V 60 Hz	CA 220 V ~ 240 V 50 Hz
Poder de la luz	5~6 W (Espectro completo) / 2 luces	
Niveles de estantería	7 niveles	
Color	Marrón y negro	
Material	Metales y tableros de partículas	

PARTS LIST

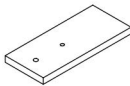
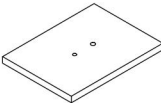
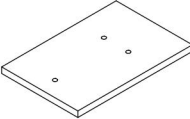
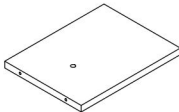
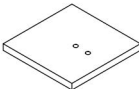
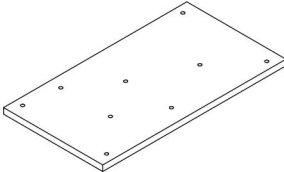
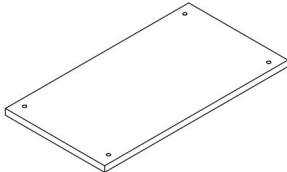

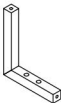
No.	PICTURE	SIZE	QTY	No.	PICTURE	SIZE	QTY
A		M6*10	8	G		S	2
B		M6*30	12	H			2
C		M6*35	18	I		ST5*40	4
D		M6*30	18				
E		ST7*40	4				
F		40*40*5	8				1

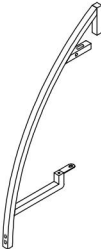
PARTS LIST

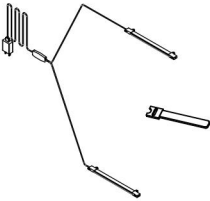
<p>1</p>  <p>X2</p>	<p>2</p>  <p>X2</p>	<p>3</p>  <p>X2</p>
<p>4</p>  <p>X2</p>	<p>5</p>  <p>X2</p>	<p>6</p>  <p>X2</p>
<p>7</p>  <p>X2</p>	<p>8</p>  <p>X8</p>	<p>9</p>  <p>X2</p>
<p>10</p>  <p>X2</p>	<p>11</p>  <p>X2</p>	<p>12</p>  <p>X2</p>
<p>13</p>  <p>X2</p>	<p>14</p>  <p>X2</p>	

ASSEMBLY INSTRUCTION

Matters needing attention

(1) When installing the screws in the installation step, the screws do not need to be tightened.

then tighten all the screws.

After this installation step is confirmed and the holes are aligned,

(2) If the screws are tightened during the installation process, it will cause problems such as misalignment of the screw holes and misalignment of the board in subsequent installations.

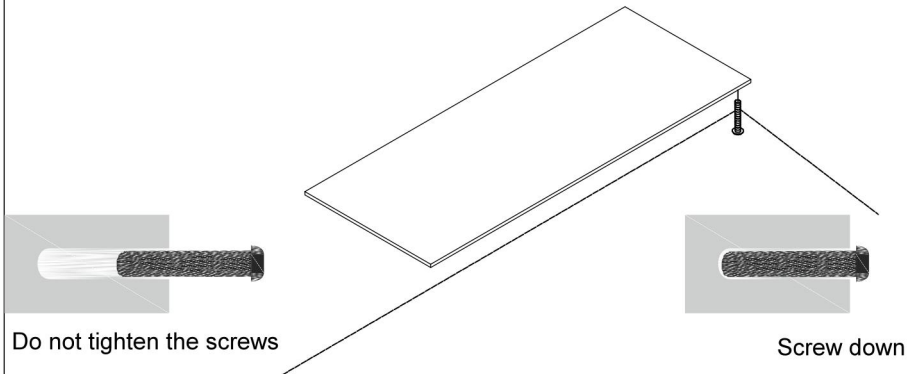

If you encounter any problems during the installation or use you can contact us at any time, we will resolve your issue within 24 hours

ASSEMBLY INSTRUCTION

STEP 1

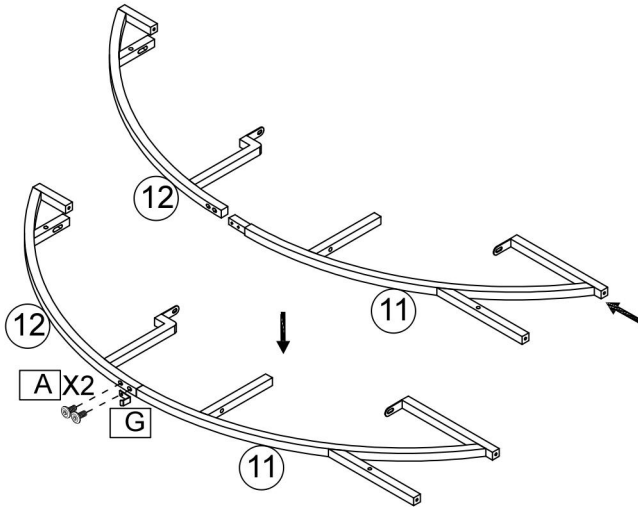

X2

A M6*10mm  X4	G  X2
--	--

STEP 2

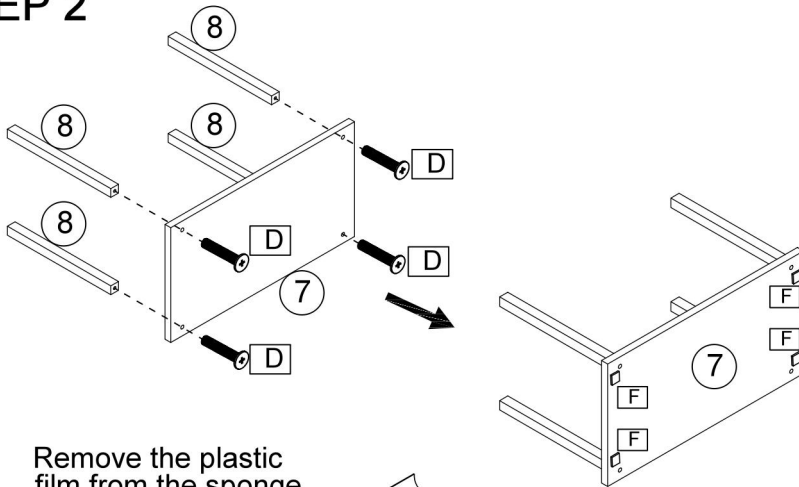

Remove the plastic film from the sponge pad before installation

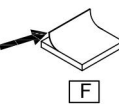

X2

D M6*30mm  X8	F 40*40*5mm  X8
--	--

ASSEMBLY INSTRUCTION

STEP 3

Please note that the left and right wooden boards can be interchanged, just flip the 6th board over.

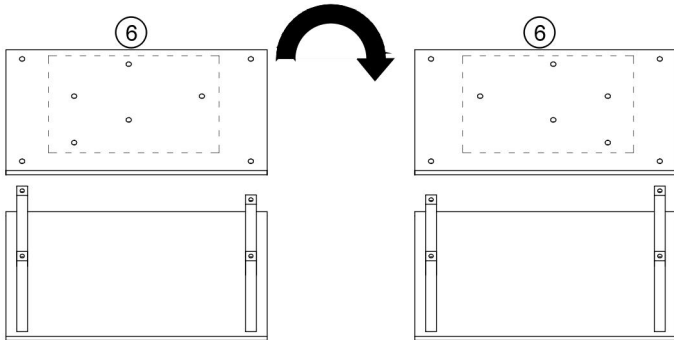

Note the direction of the hole in Board No. 6. The Hole in the left picture represents the left side, and the hole in the right picture represents the right side when the board No. 6 is reversed.

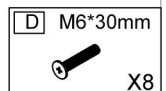
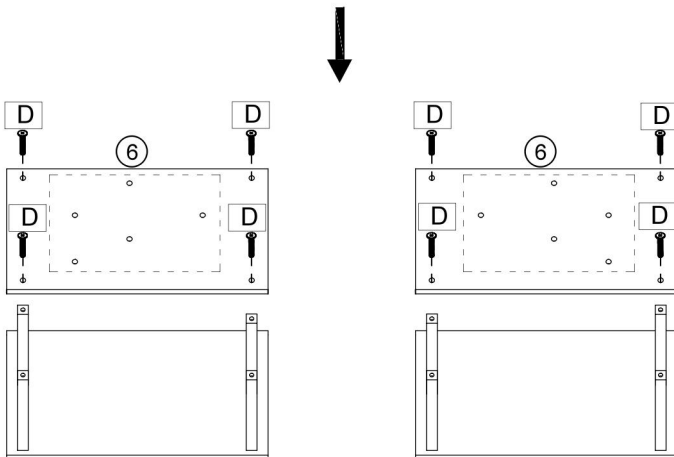

ASSEMBLY INSTRUCTION

STEP 4

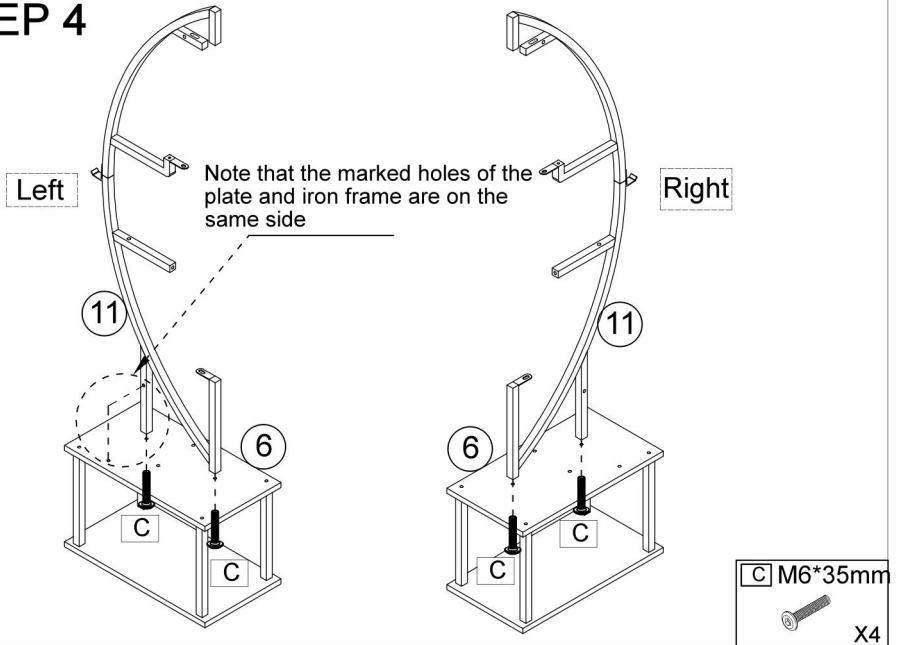

STEP 5

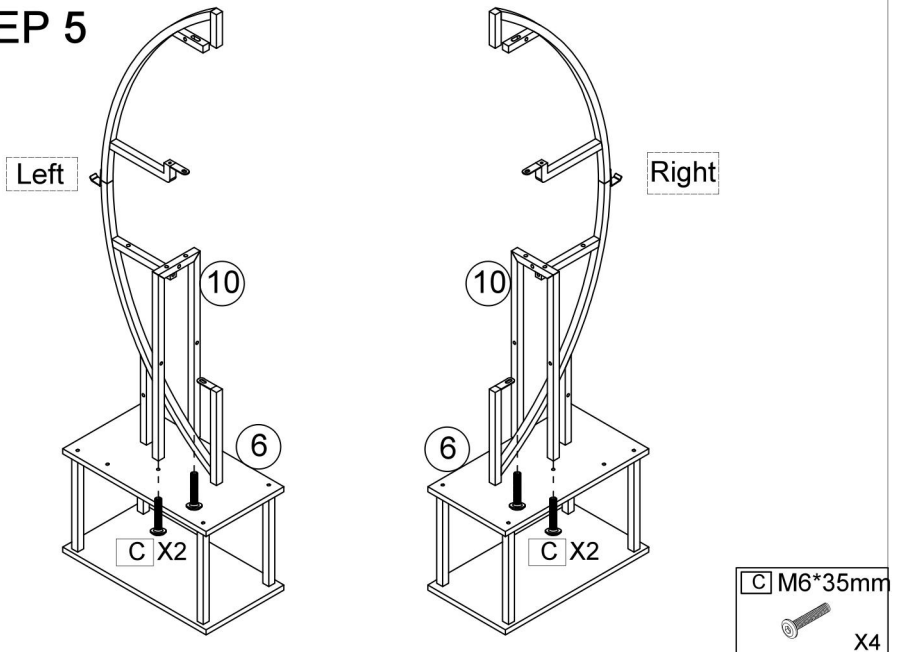

ASSEMBLY INSTRUCTION

STEP 6

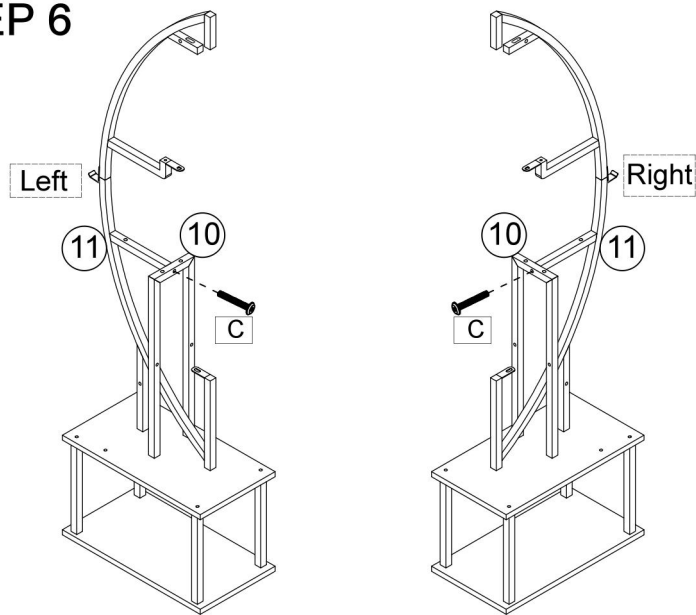

STEP 7

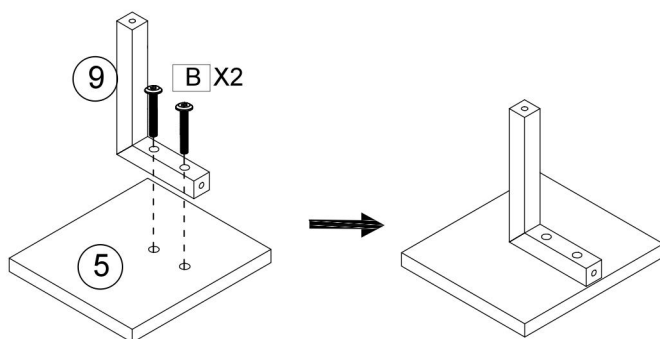

X2

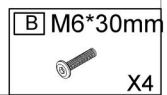

ASSEMBLY INSTRUCTION

STEP 8

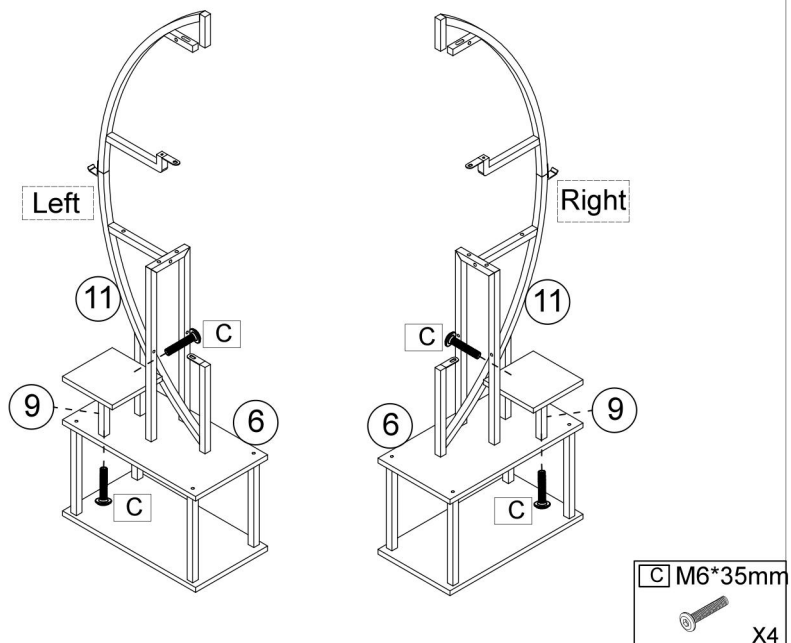

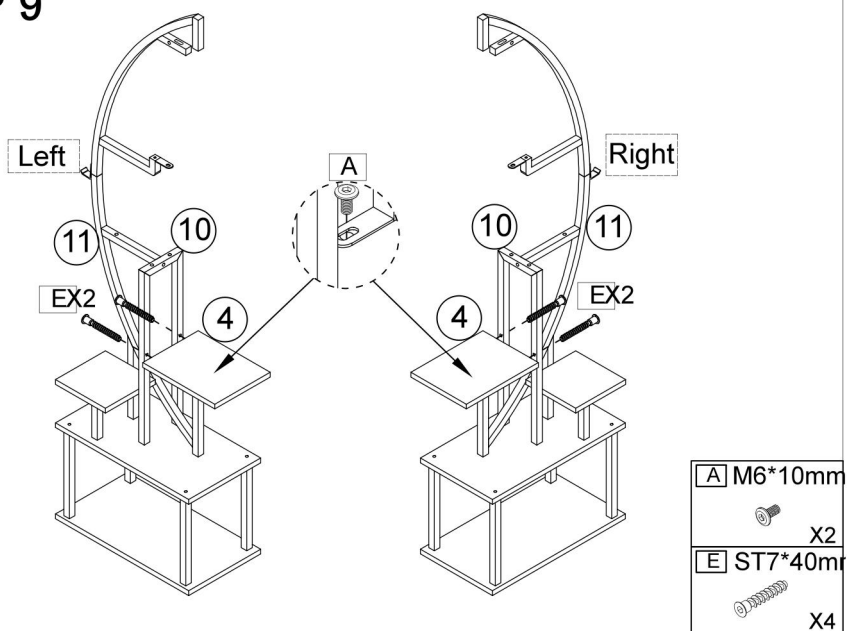

STEP 9

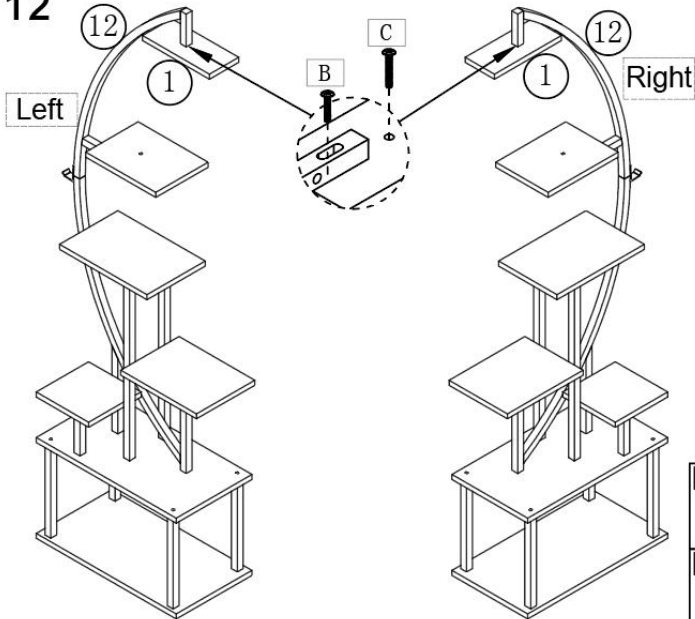

ASSEMBLY INSTRUCTION

STEP 12



B	M6*30mm
	X2
C	M6*35mm
	X2

STEP 13

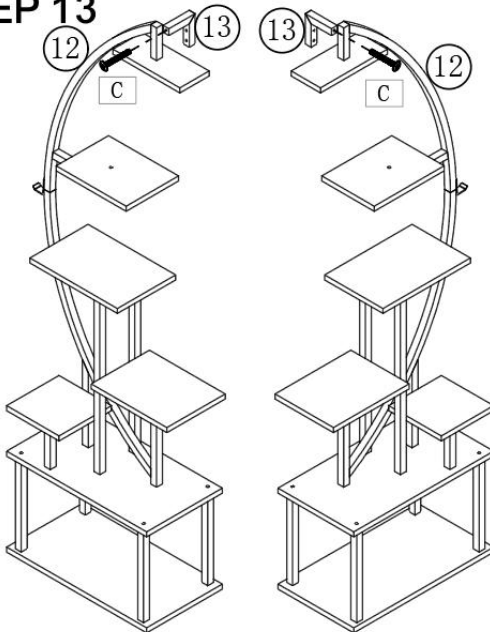



13



H

Anti-tilt



Note that you can choose an anti-tilt rack or fixing belt according to your needs.

If you select a fixed belt, please refer to steps 15-16

13		X2
C	M6*35mm	X2

ASSEMBLY INSTRUCTION

STEP 14

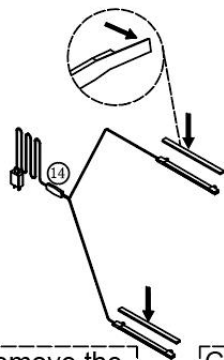

Carefully remove the plastic film behind the light strip

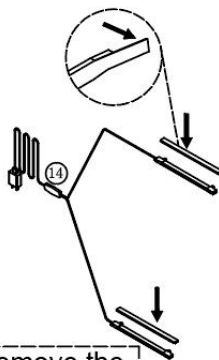

Carefully remove the plastic film behind the light strip

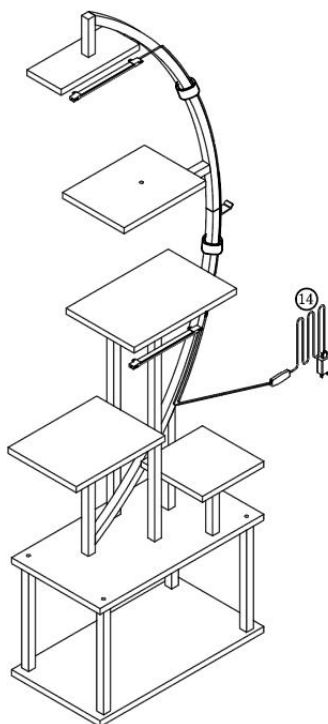
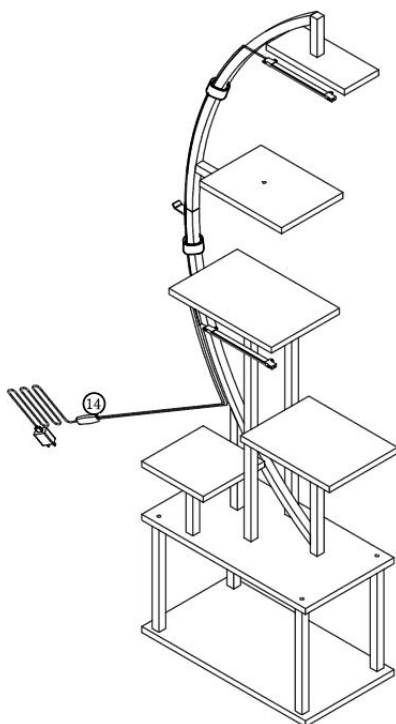

ASSEMBLY INSTRUCTION

STEP 15

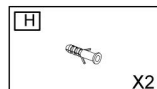
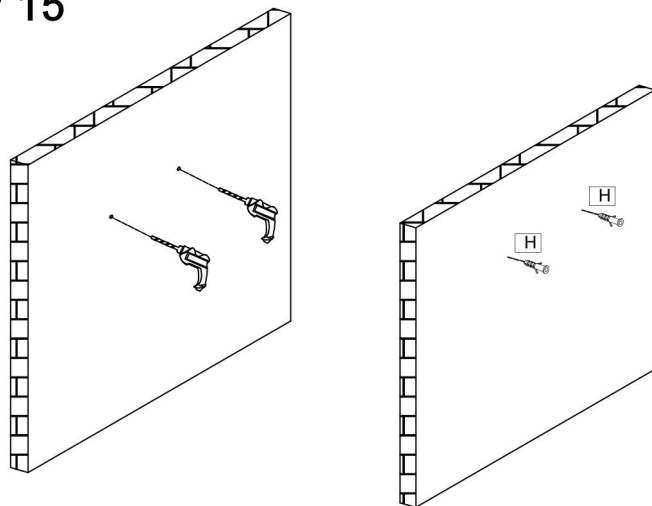

STEP 16

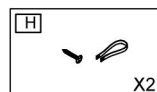
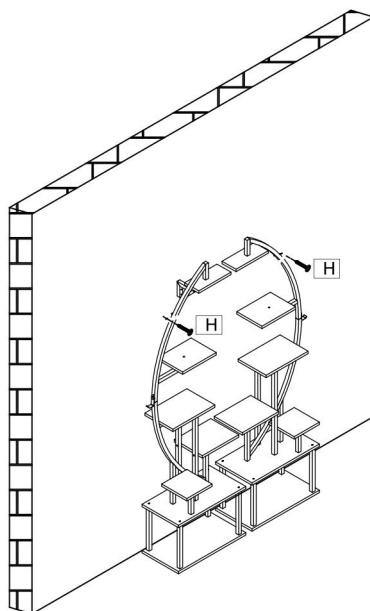

ASSEMBLY INSTRUCTION

STEP 17

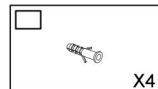
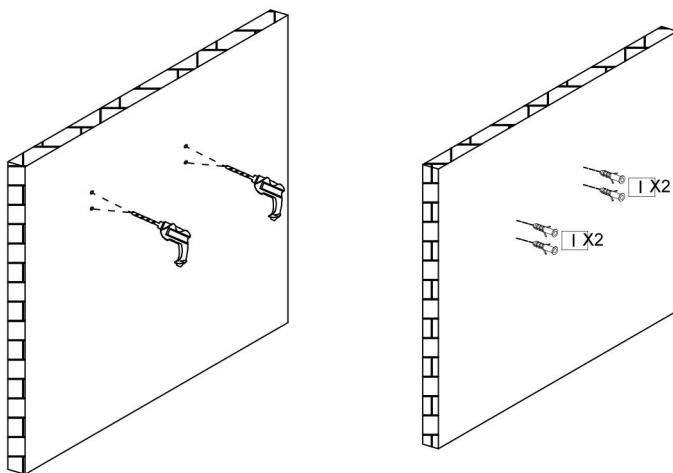

STEP 18

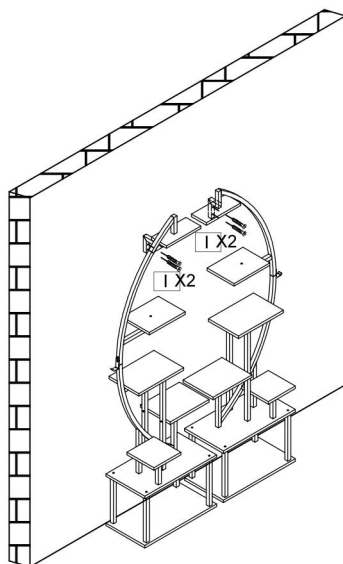

FCC INFORMATION

PRECAUCIONES: Cambios o modificaciones no aprobados expresamente por la parte responsable ¡El cumplimiento podría anular la autoridad del usuario para operar el equipo!

Este dispositivo cumple con la Parte 15 de las Normas de la FCC. Su funcionamiento está sujeto a las siguientes normas: dos condiciones:

- 1) Este producto puede causar interferencias dañinas.
- 2) Este producto debe aceptar cualquier interferencia recibida, incluida la interferencia que pueda provocar un funcionamiento no deseado.

ADVERTENCIA: Los cambios o modificaciones no aprobados expresamente por la parte responsable del cumplimiento podrían anular la autoridad del usuario para operar el equipo.

NOTA: Este equipo ha sido probado y cumple con los límites establecidos para dispositivos digitales de Clase B, según la Parte 15 de las Normas de la FCC. Estos límites están diseñados para brindar una protección razonable contra interferencias perjudiciales en instalaciones residenciales. Esta unidad genera, utiliza y puede radiar energía de radiofrecuencia y, si no se instala y utiliza de acuerdo con las instrucciones, puede causar interferencias perjudiciales en las comunicaciones por radio. Sin embargo, no se garantiza que no se produzcan interferencias en una instalación específica. Si este equipo causa interferencias perjudiciales en la recepción de radio o televisión, se pueden tomar una o más de las siguientes medidas:

- Reorientar o reubicar la antena receptora.
- Aumentar la separación entre el equipo y el receptor.
- Conecte el equipo a una toma de corriente de un circuito diferente a aquel al que está conectado el receptor.
- Consulte al distribuidor o a un técnico de radio/TV experimentado para obtener ayuda.

Fabricante: Shanghaimuxinmuyeyouxiangongsi

DIRECCIÓN: Shuangchenglu 803nong11hao1602A-1609shi, baoshanqu ,
Shanghái 200000 CN.

Importado a EE.UU.: Sanven Technology Ltd. Suite 250, 9166 Anaheim
Lugar, Rancho Cucamonga, CA 91730

UK	REP
-----------	------------

YH CONSULTING LIMITED. C/O YH Consulting
Limited Office 147, Centurion House, London
Road, Staines-upon-Thames, Surrey, TW18 4AX

EC	REP
-----------	------------

E-CrossStu GmbH
Mainzer Landstr.69,
60329 Frankfurt am Main.



VEVOR

Affordable. Reliable. Home Improvement.

SUPPORTI PER PIANTE

(CON LUCE LED PER LA CRESCITA : ZWLDT-02)



MANUALE D'USO

MODELLO: SSPS-0 3 -US \ SSPS -0 3 -UE

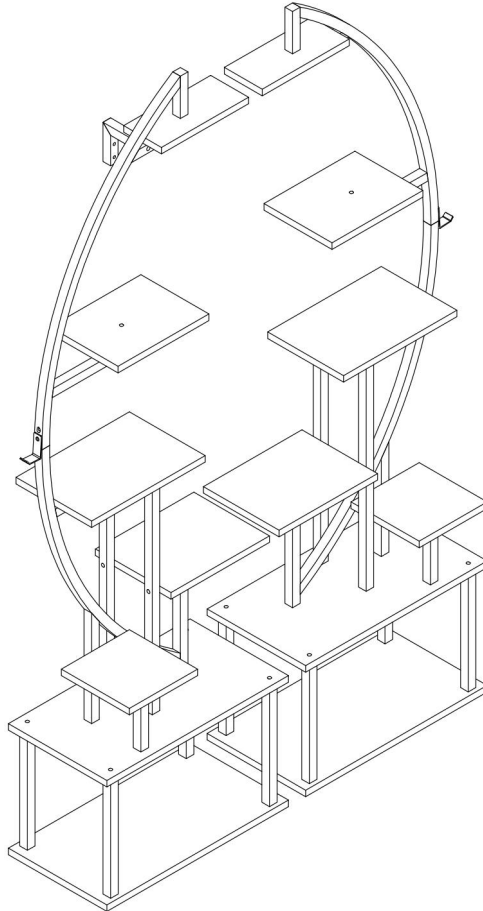
MODELLO: SSPS-0 3 -US \ SSPS -0 3 -UE



Queste sono le istruzioni originali, si prega di leggere attentamente tutte le istruzioni del manuale prima di utilizzare il prodotto. VEVOR si riserva la piena interpretazione del manuale utente. L'aspetto del prodotto dipenderà dal prodotto ricevuto. Vi preghiamo di non informarvi ulteriormente in caso di aggiornamenti tecnologici o software relativi al nostro prodotto.

	<p>Avvertenza: per ridurre il rischio di lesioni, l'utente deve leggere attentamente il manuale di istruzioni.</p> <p>LEGGERE TUTTE LE ISTRUZIONI PRIMA DELL'USO</p> <p>È necessario leggere tutte le istruzioni di sicurezza e di funzionamento, rispettate e seguite prima di mettere in funzione l'unità.</p>
	<p>Questo dispositivo è conforme alla Parte 15 delle Norme FCC. Il funzionamento è soggetto alle seguenti due condizioni: (1) questo dispositivo non deve causare interferenze dannose e (2) questo dispositivo deve accettare qualsiasi interferenza ricevuta, comprese quelle che potrebbero causare un funzionamento indesiderato.</p>

SAFETY INSTRUCTIONS

Grazie per aver acquistato i nostri supporti per piante .

- Prima di utilizzare il prodotto, vi preghiamo di leggere attentamente e seguire le istruzioni fornite di seguito. Installando o utilizzando il prodotto, dichiarate di aver letto attentamente e accettato le seguenti istruzioni di sicurezza.
- Si prega di conservare questo manuale per riferimento futuro.

Note importanti:

- (1) La lampada da coltivazione è destinata esclusivamente all'uso in ambienti interni.
- (2) La lampada da coltivazione non è impermeabile, non lasciarla immersa nell'acqua.
- (3) Si prega di scollegare l'alimentazione quando c'è tuono.
- (4) Assicurarsi che il prodotto venga utilizzato in un ambiente normale. L'ambiente di funzionamento della lampada dovrebbe essere inferiore a +104 ° F e 80%RH.

Linee guida di sicurezza:

- La violazione delle seguenti istruzioni può comportare un utilizzo anomalo del prodotto o perdite impreviste. Si consiglia vivamente di attenersi scrupolosamente alle seguenti linee guida.
- Installare e utilizzare il prodotto rigorosamente in conformità con le istruzioni fornite istruzioni.

PRODUCT DESCRIPTION

- Le lampade a LED per la coltivazione sono un'ottima opzione per la coltivazione di piante, rispetto alle lampade tradizionali.
- La lampada da coltivazione ha un PPFD più elevato, un consumo energetico inferiore e una durata maggiore.





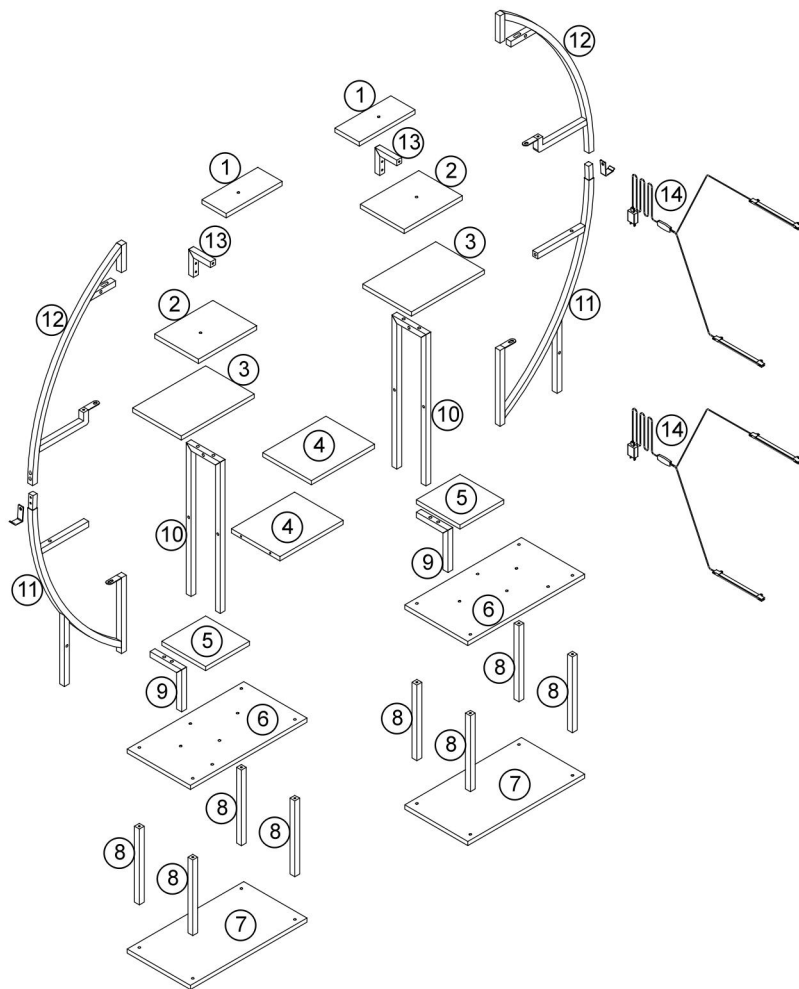

Modello	SSPS-0 3 -US	SSPS-0 3 -UE
LUCE A LED PER LA COLTIVAZIONE	Z WLDT-02	
Quartiere	America del Nord	Europa
Tensione dell'adattatore	CA 110 V ~ 120 V 60 Hz	CA 220 V ~ 240 V 50 Hz
Potenza luminosa	5~6 W (Spettro completo) / 2 luci	
Livelli degli scaffali	7 livelli	
Colore	Marrone e nero	
Materiale	Metalli e pannelli truciolari	

PARTS LIST

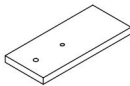
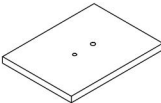
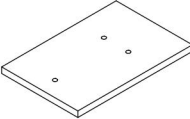
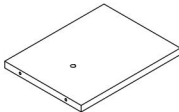
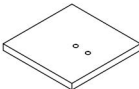
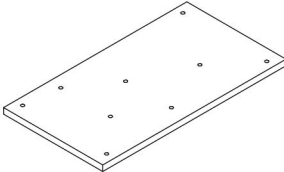
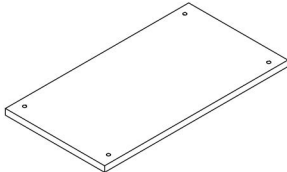

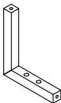
No.	PICTURE	SIZE	QTY	No.	PICTURE	SIZE	QTY
A		M6*10	8	G		S	2
B		M6*30	12	H			2
C		M6*35	18	I		ST5*40	4
D		M6*30	18				
E		ST7*40	4				
F		40*40*5	8				1

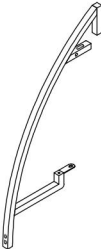
PARTS LIST

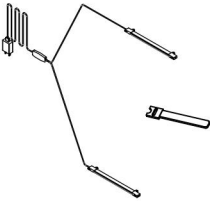
<p>1</p>  <p>X2</p>	<p>2</p>  <p>X2</p>	<p>3</p>  <p>X2</p>
<p>4</p>  <p>X2</p>	<p>5</p>  <p>X2</p>	<p>6</p>  <p>X2</p>
<p>7</p>  <p>X2</p>	<p>8</p>  <p>X8</p>	<p>9</p>  <p>X2</p>
<p>10</p>  <p>X2</p>	<p>11</p>  <p>X2</p>	<p>12</p>  <p>X2</p>
<p>13</p>  <p>X2</p>	<p>14</p>  <p>X2</p>	

ASSEMBLY INSTRUCTION

Matters needing attention

(1) When installing the screws in the installation step, the screws do not need to be tightened.

then tighten all the screws.

After this installation step is confirmed and the holes are aligned,

(2) If the screws are tightened during the installation process, it will cause problems such as misalignment of the screw holes and misalignment of the board in subsequent installations.

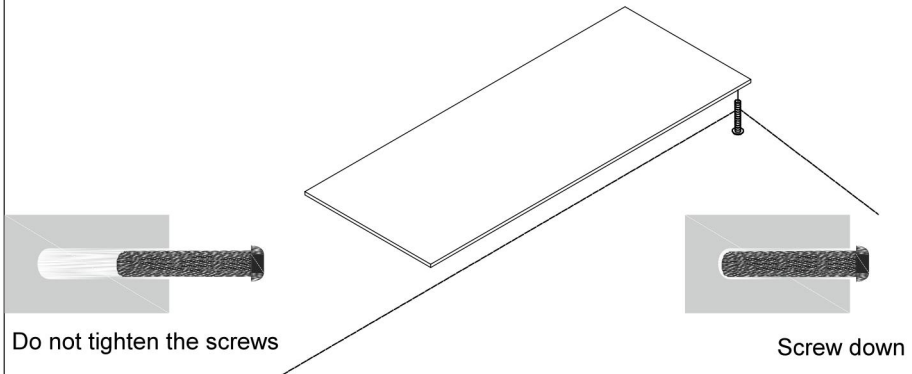

If you encounter any problems during the installation or use you can contact us at any time, we will resolve your issue within 24 hours

ASSEMBLY INSTRUCTION

STEP 1

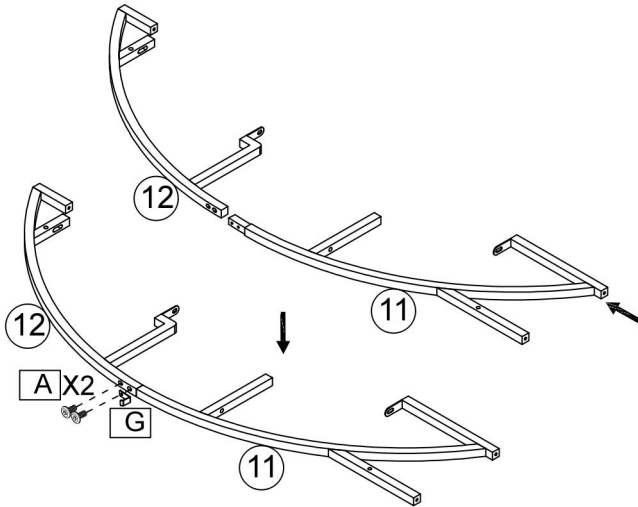

X2

A M6*10mm  X4	G  X2
--	--

STEP 2

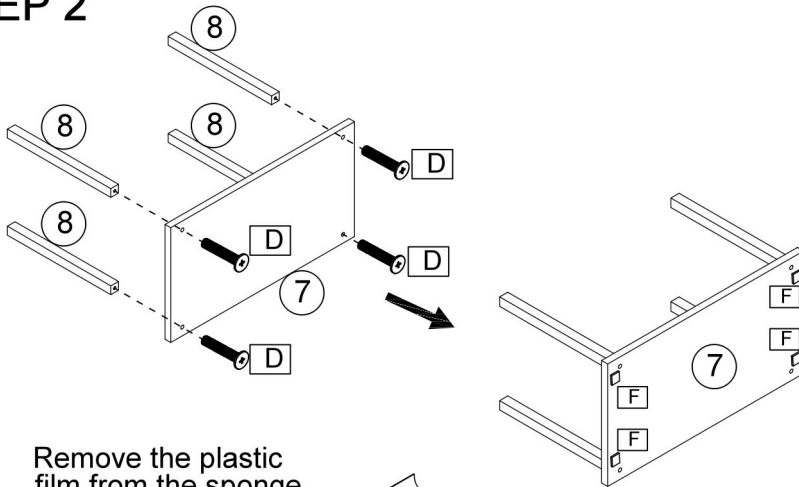

Remove the plastic film from the sponge pad before installation

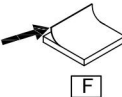

X2

D M6*30mm  X8	F 40*40*5mm  X8
--	--

ASSEMBLY INSTRUCTION

STEP 3

Please note that the left and right wooden boards can be interchanged, just flip the 6th board over.

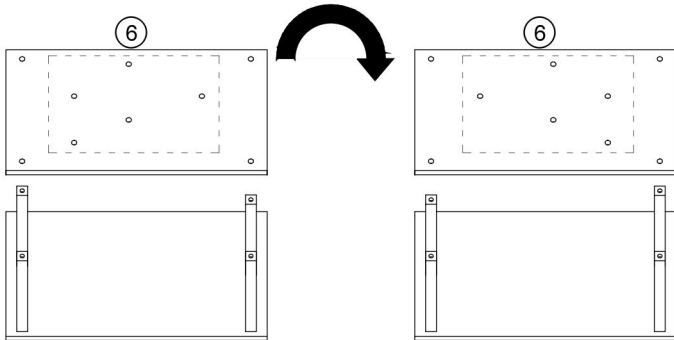

Note the direction of the hole in Board No. 6. The Hole in the left picture represents the left side, and the hole in the right picture represents the right side when the board No. 6 is reversed.

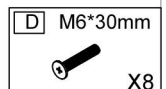
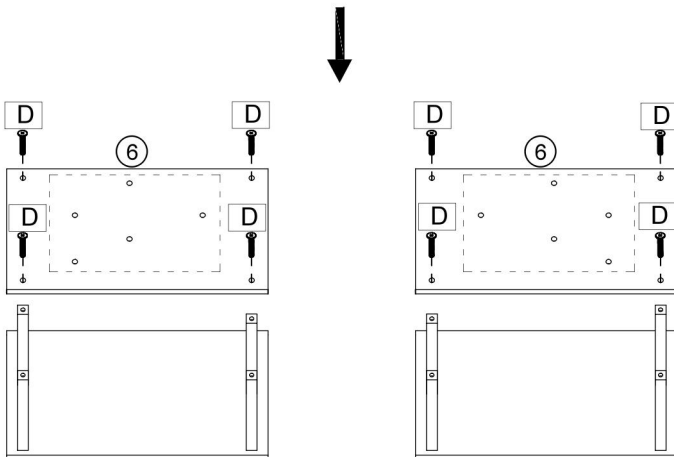

ASSEMBLY INSTRUCTION

STEP 4

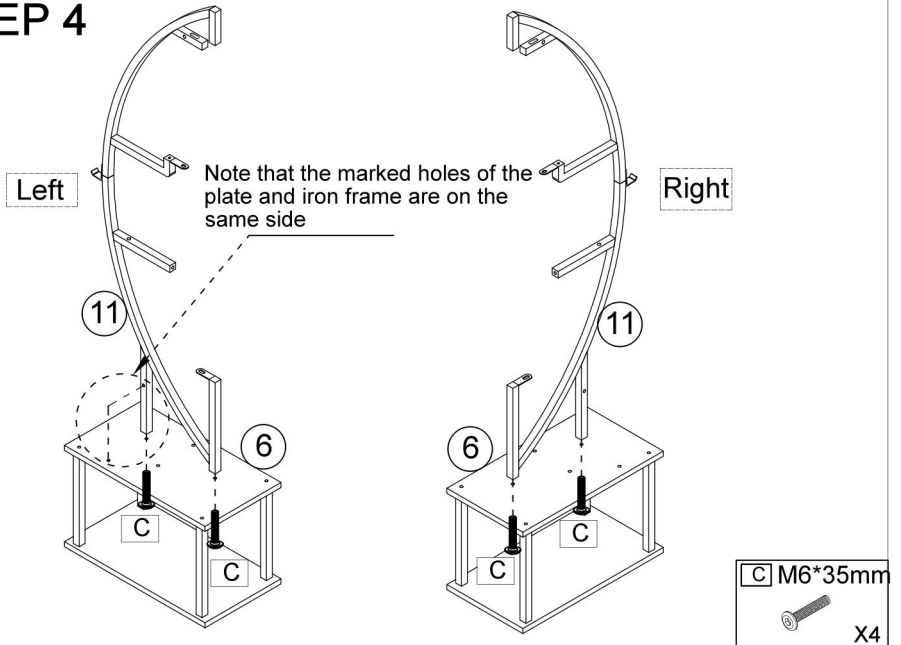

STEP 5

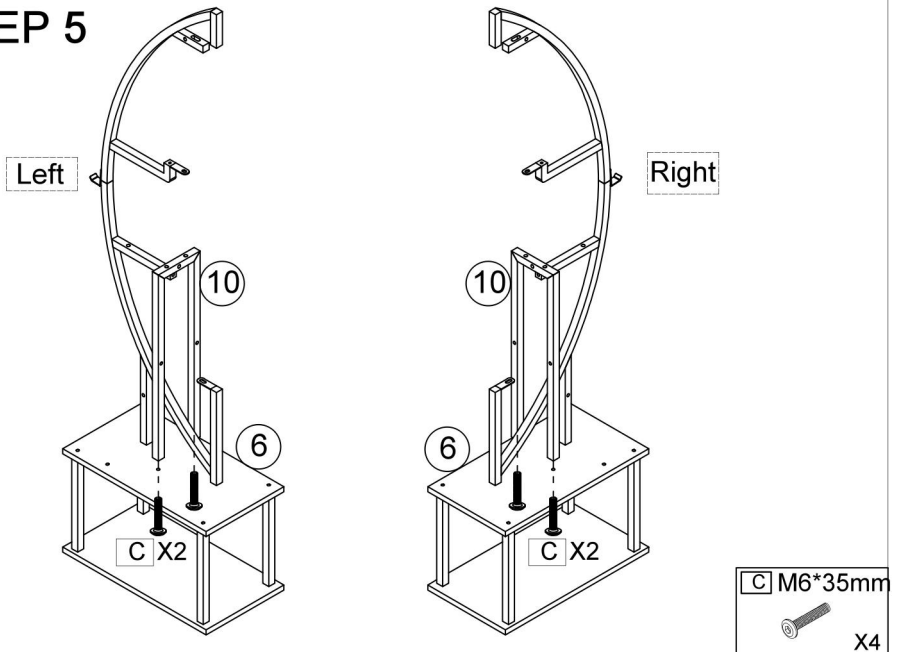

ASSEMBLY INSTRUCTION

STEP 6

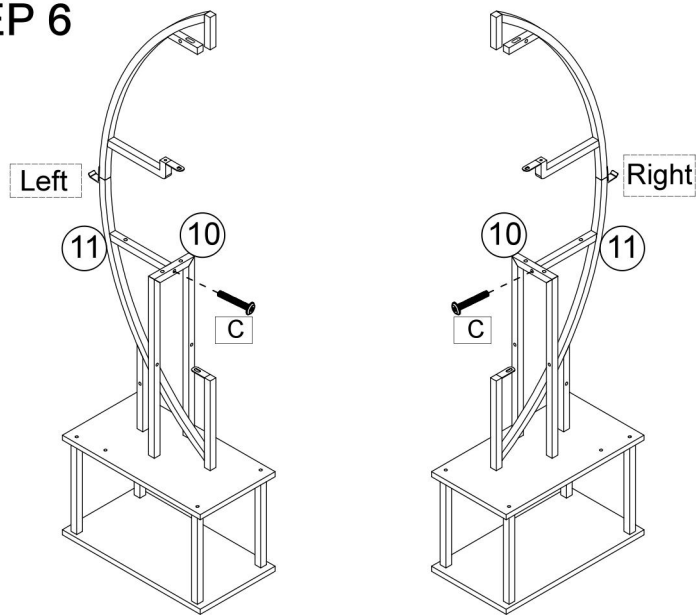

STEP 7

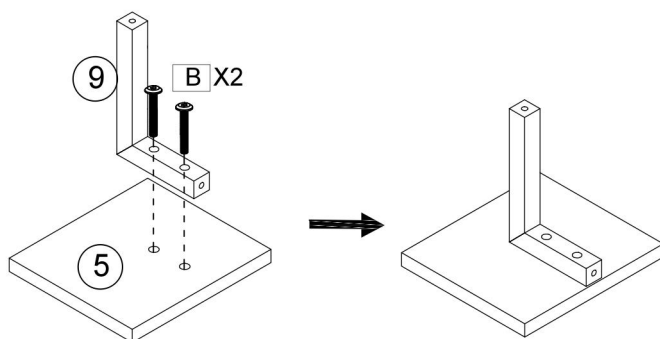

X2

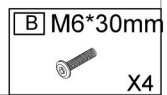

ASSEMBLY INSTRUCTION

STEP 8

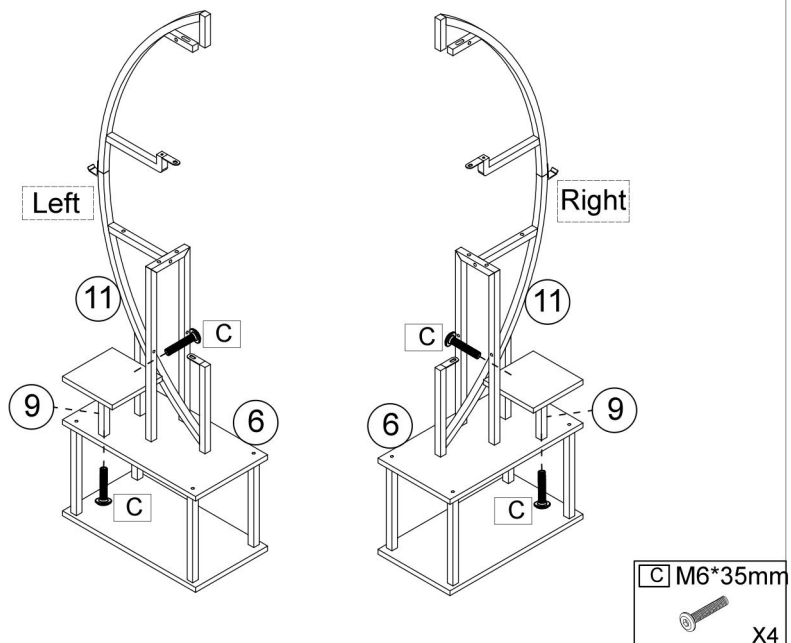

STEP 9

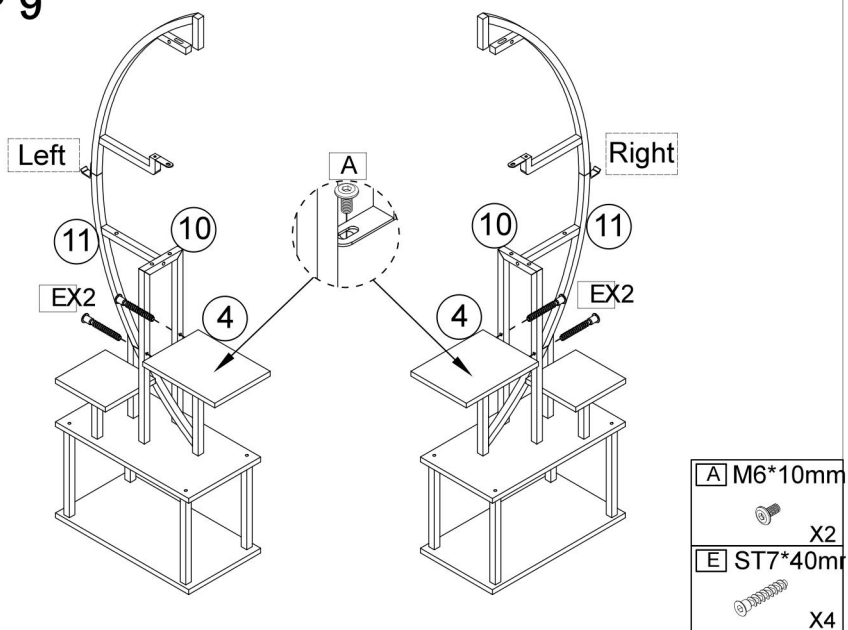

ASSEMBLY INSTRUCTION

STEP 10

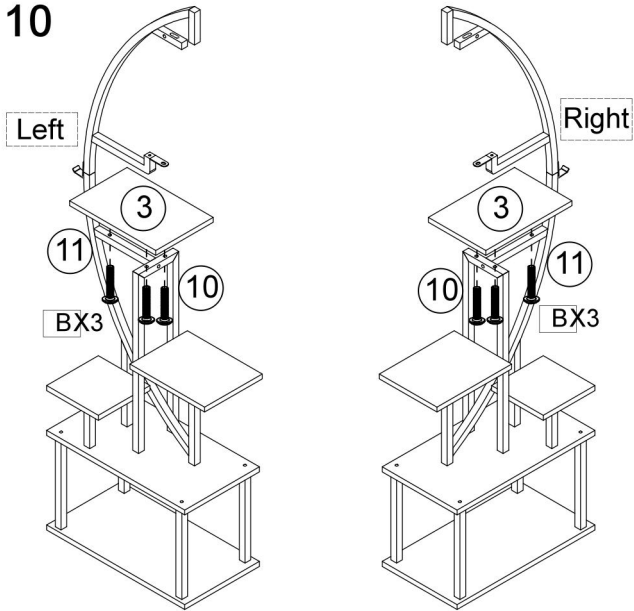

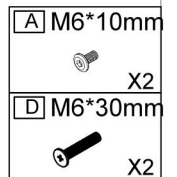
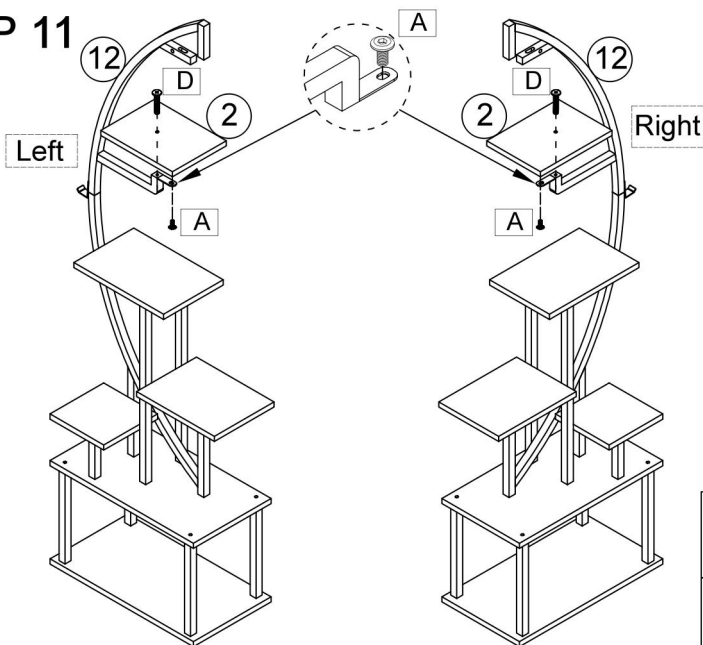

STEP 11

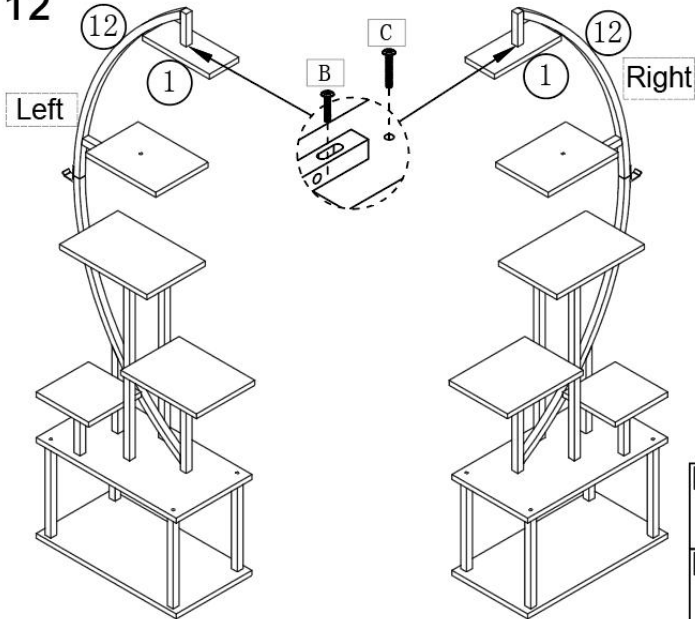

ASSEMBLY INSTRUCTION

STEP 12



B	M6*30mm
	X2
C	M6*35mm
	X2

STEP 13

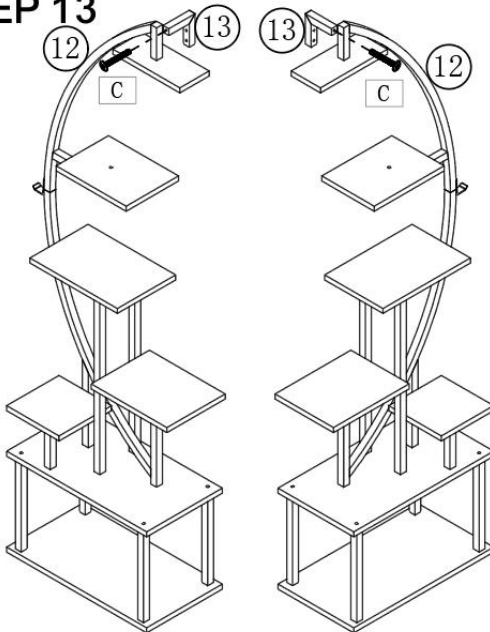



13



H

Anti-tilt



Note that you can choose an anti-tilt rack or fixing belt according to your needs.

If you select a fixed belt, please refer to steps 15-16

13		X2
C	M6*35mm	X2

ASSEMBLY INSTRUCTION

STEP 14

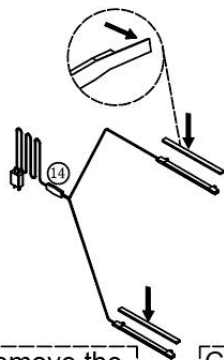

Carefully remove the plastic film behind the light strip

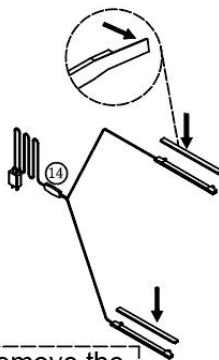

Carefully remove the plastic film behind the light strip

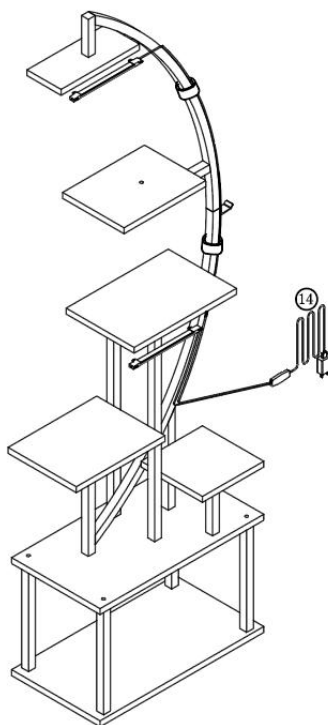
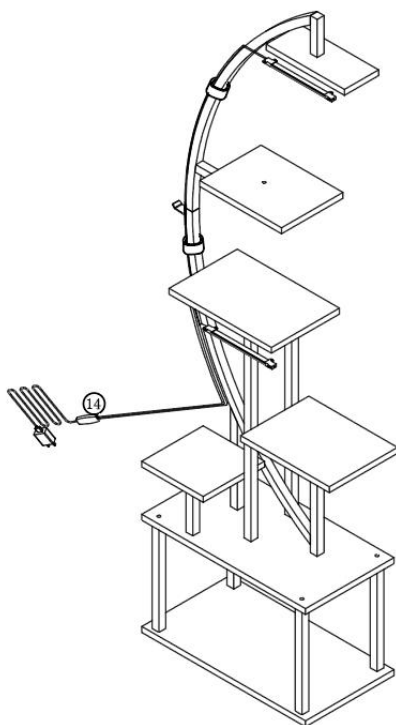

ASSEMBLY INSTRUCTION

STEP 15

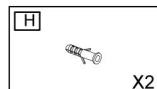
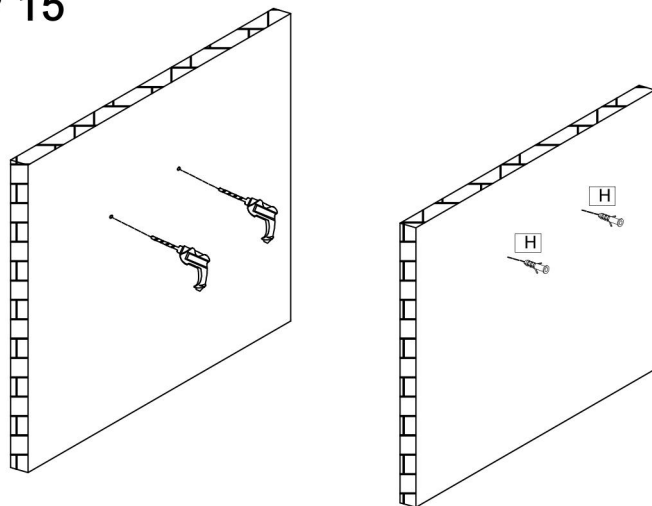

STEP 16

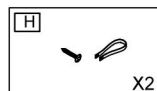
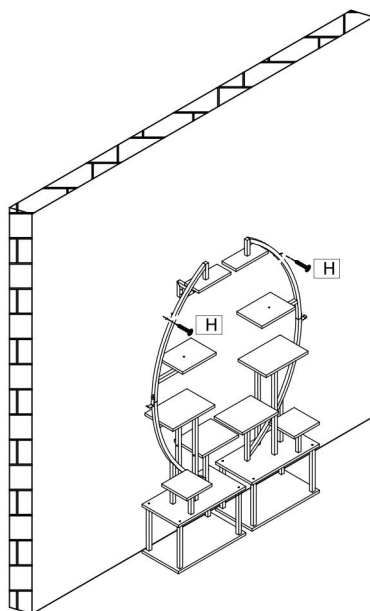

ASSEMBLY INSTRUCTION

STEP 17

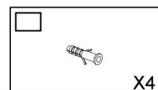
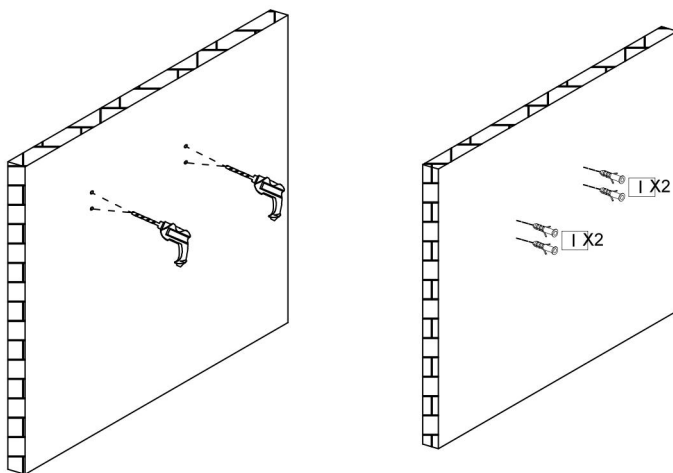

STEP 18

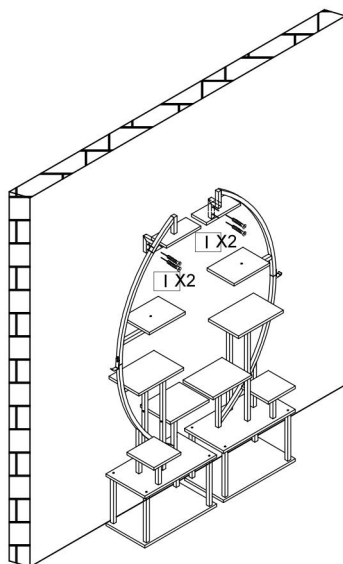

FCC INFORMATION

ATTENZIONE: Cambiamenti o modifiche non espressamente approvati dal soggetto responsabile La conformità potrebbe invalidare il diritto dell'utente a utilizzare l'apparecchiatura!

Questo dispositivo è conforme alla Parte 15 delle Norme FCC. Il funzionamento è soggetto alle seguenti due condizioni:

- 1) Questo prodotto potrebbe causare interferenze dannose.
- 2) Questo prodotto deve accettare qualsiasi interferenza ricevuta, comprese le interferenze che potrebbero causare un funzionamento indesiderato.

ATTENZIONE: Cambiamenti o modifiche non espressamente approvati dalla parte responsabile della conformità potrebbero invalidare il diritto dell'utente a utilizzare l'apparecchiatura.

NOTA: Questa apparecchiatura è stata testata e ritenuta conforme ai limiti previsti per i dispositivi digitali di Classe B, ai sensi della Parte 15 delle Norme FCC. Tali limiti sono concepiti per fornire una protezione ragionevole contro le interferenze dannose in un'installazione residenziale. Questa unità genera, utilizza e può irradiare energia a radiofrequenza e, se non installata e utilizzata in conformità alle istruzioni, può causare interferenze dannose alle comunicazioni radio. Tuttavia, non vi è alcuna garanzia che non si verifichino interferenze in una particolare installazione. Se questa apparecchiatura dovesse causare interferenze dannose alla ricezione radiofonica o televisiva, è possibile adottare una o più delle seguenti misure:

- Riorientare o riposizionare l'antenna ricevente.
- Aumentare la distanza tra l'apparecchiatura e il ricevitore.
- Collegare l'apparecchiatura a una presa di corrente appartenente a un circuito diverso da quello a cui è collegato il ricevitore.
- Per assistenza, rivolgersi al rivenditore o a un tecnico radio/TV esperto.

Produttore: Shanghaimuxinmuyeyouxiangongsi

Indirizzo: Shuangchenglu 803nong11hao1602A-1609shi, baoshanqu , shanghai 200000 CN.

Importato negli USA: Sanven Technology Ltd. Suite 250, 9166 Anaheim Luogo, Rancho Cucamonga, CA 91730

UK	REP
-----------	------------

YH CONSULTING LIMITED. C/O YH Consulting Limited Office 147, Centurion House, London Road, Staines-upon-Thames, Surrey, TW18 4AX

EC	REP
-----------	------------

E-CrossStu GmbH
Mainzer Landstr.69,
60329 Frankfurt am Main.



VEVOR

Affordable. Reliable. Home Improvement.

VÄXTSTÄLL

(MED LED-VÄXTLAMPOR : ZWLDT-02)



ANVÄNDARMANUAL

MODELL: SSPS-0 3 -US \ SSPS-0 3 - EU

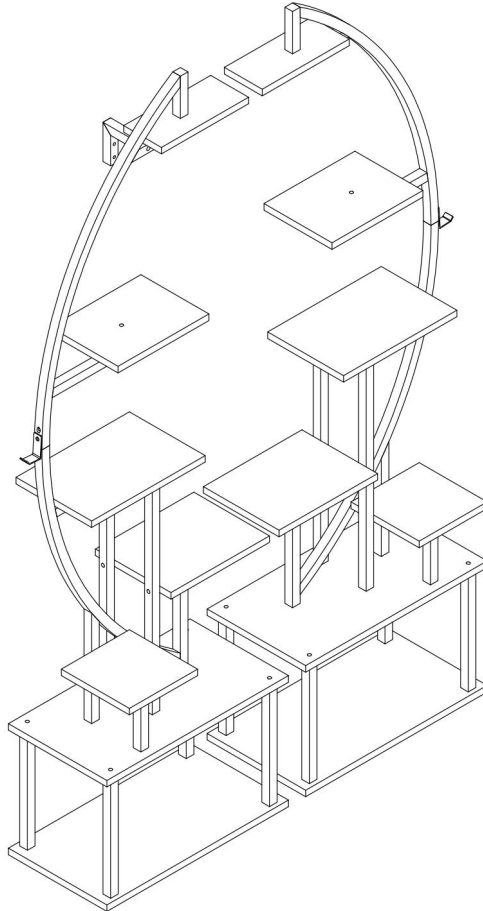
MODELL: SSPS-0 3 -US \ SSPS-0 3 - EU



Detta är originalinstruktionerna, vänligen läs alla instruktioner noggrant innan du använder produkten. VEVOR förbehåller sig en tydlig tolkning av vår användarmanual. Produktens utseende ska vara beroende av den produkt du mottagit. Vi ber om ursäkt för att vi inte kommer att informera dig igen om det finns några teknik- eller programuppdateringar för vår produkt.

	<p>Varning – För att minska risken för skador måste användaren läsa instruktionsmanualen noggrant.</p> <p>LÄS ALLA INSTRUKTIONER FÖRE ANVÄNDNING</p> <p>Alla säkerhets- och bruksanvisningar bör läsas, följs innan enheten används.</p>
	<p>Denna enhet uppfyller del 15 i FCC-reglerna. Användning är underkastad följande två villkor: (1) Denna enhet får inte orsaka skadliga störningar, och (2) denna enhet måste acceptera alla mottagna störningar, inklusive störningar som kan orsaka oönskad drift.</p>

SAFETY INSTRUCTIONS

Tack för att du köpte våra växtställ .

- Innan du använder produkten ber vi dig vänligen att noggrant läsa och följa instruktionerna nedan. Genom att installera eller använda produkten bekräftar du att du noggrant har läst och godkänt följande säkerhetsinstruktioner.
- Se till att spara denna manual för framtida bruk.

Viktiga anmärkningar:

- (1) Växtlampan är endast avsedd för inomhusbruk.
- (2) Växtlampan är inte vattentät, låt den inte blötläggas i vatten.
- (3) Var vänlig och stäng av strömmen när det åskar.
- (4) Se till att produkten används i normal miljö. Lampans arbetsmiljö bör vara lägre än +104 ° F och 80 % RF.

Säkerhetsriktlinjer:

- Överträdelse av följande instruktioner kan leda till onormal användning av produkten eller oväntade förluster. Vi rekommenderar starkt att du strikt följer följande riktlinjer.
- Installera och använd produkten strikt i enlighet med anvisningarna instruktioner.

PRODUCT DESCRIPTION

- LED-växtlampa är ett utmärkt alternativ för att odla växter. Jämfört med traditionell växtlampa.
- Växtljus har högre PPFD, lägre strömförbrukning och längre livslängd.





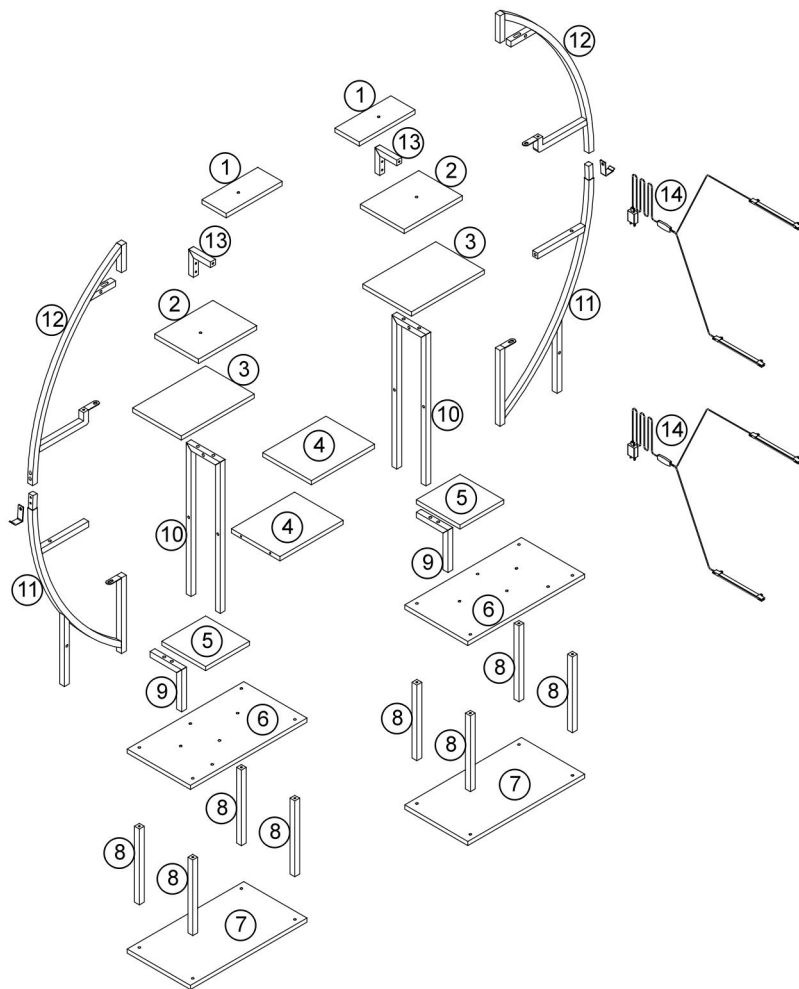

Modell	SSPS-0 3 -USA	SSPS-0 3 -EU
LED-växellampa	Z WLDT-02	
Distrikt	Nordamerika	Europa
Adapterspänning	AC 110V~120V 60Hz	AC 220V~240V 50Hz
Ljuskraft	5~6 W (Fullspektrum) / 2 lampor	
Hyllnivåer	7 nivåer	
Färg	Brun och svart	
Material	Metaller och spånskivor	

PARTS LIST

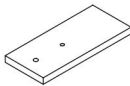
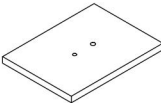
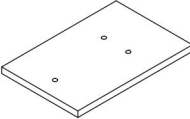
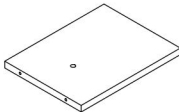
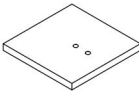
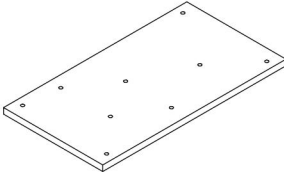
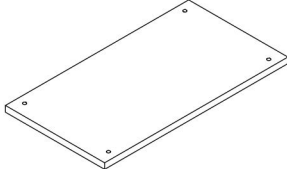

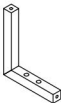
No.	PICTURE	SIZE	QTY	No.	PICTURE	SIZE	QTY
A		M6*10	8	G		S	2
B		M6*30	12	H			2
C		M6*35	18	I		ST5*40	4
D		M6*30	18				
E		ST7*40	4				
F		40*40*5	8				1

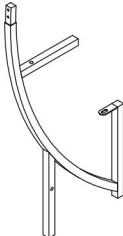
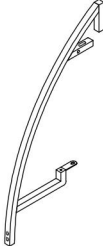
PARTS LIST

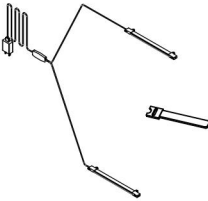
<p>1</p>  <p>X2</p>	<p>2</p>  <p>X2</p>	<p>3</p>  <p>X2</p>
<p>4</p>  <p>X2</p>	<p>5</p>  <p>X2</p>	<p>6</p>  <p>X2</p>
<p>7</p>  <p>X2</p>	<p>8</p>  <p>X8</p>	<p>9</p>  <p>X2</p>
<p>10</p>  <p>X2</p>	<p>11</p>  <p>X2</p>	<p>12</p>  <p>X2</p>
<p>13</p>  <p>X2</p>	<p>14</p>  <p>X2</p>	

ASSEMBLY INSTRUCTION

Matters needing attention

(1) When installing the screws in the installation step, the screws do not need to be tightened.

then tighten all the screws.

After this installation step is confirmed and the holes are aligned,

(2) If the screws are tightened during the installation process, it will cause problems such as misalignment of the screw holes and misalignment of the board in subsequent installations.

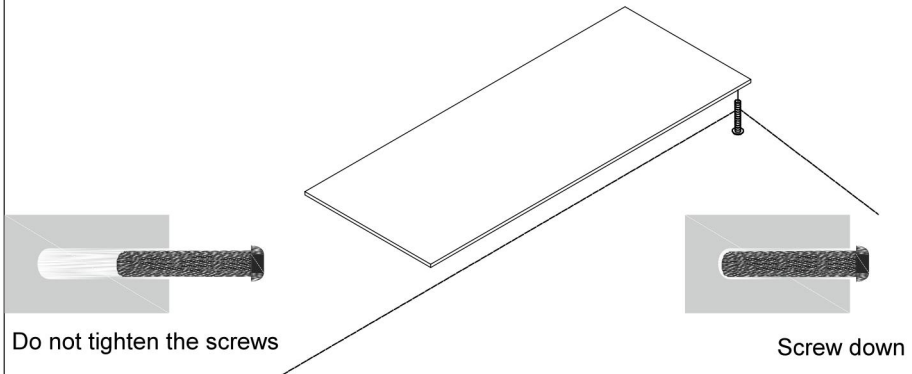

If you encounter any problems during the installation or use you can contact us at any time, we will resolve your issue within 24 hours

ASSEMBLY INSTRUCTION

STEP 1

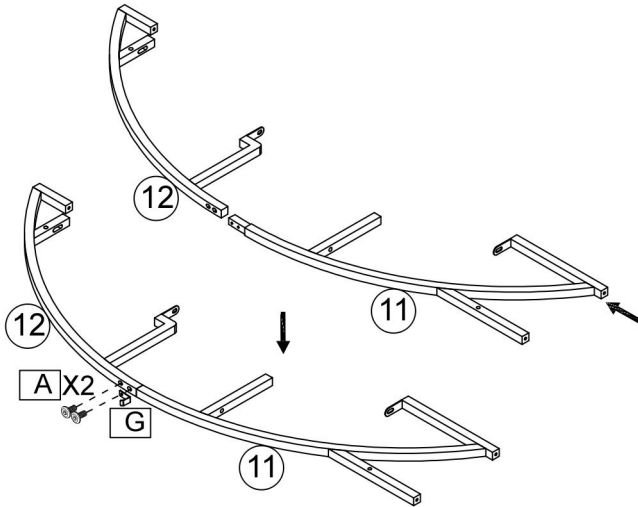

X2

A M6*10mm  X4	G  X2
--	--

STEP 2

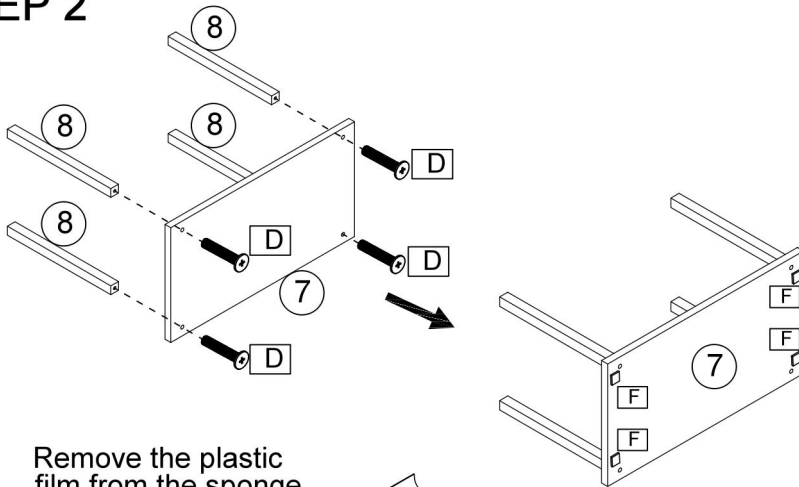

Remove the plastic film from the sponge pad before installation

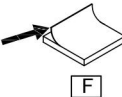

X2

D M6*30mm  X8	F 40*40*5mm  X8
--	--

ASSEMBLY INSTRUCTION

STEP 3

Please note that the left and right wooden boards can be interchanged, just flip the 6th board over.

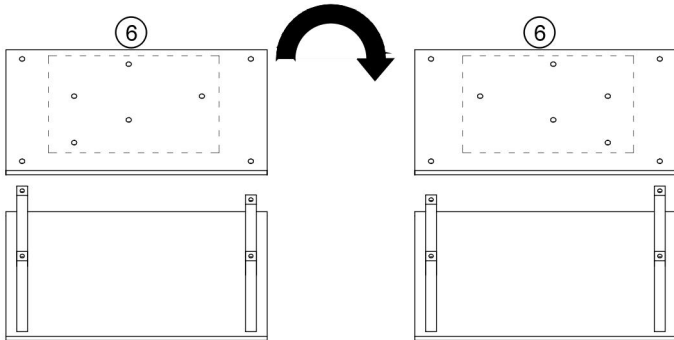

Note the direction of the hole in Board No. 6. The Hole in the left picture represents the left side, and the hole in the right picture represents the right side when the board No. 6 is reversed.

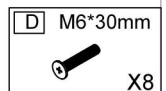
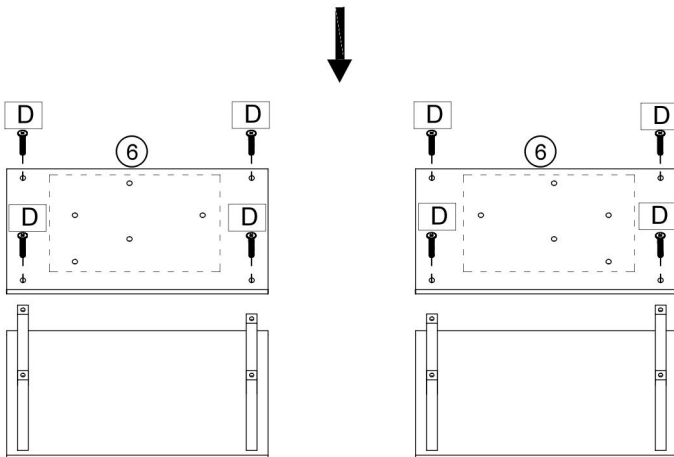

ASSEMBLY INSTRUCTION

STEP 4

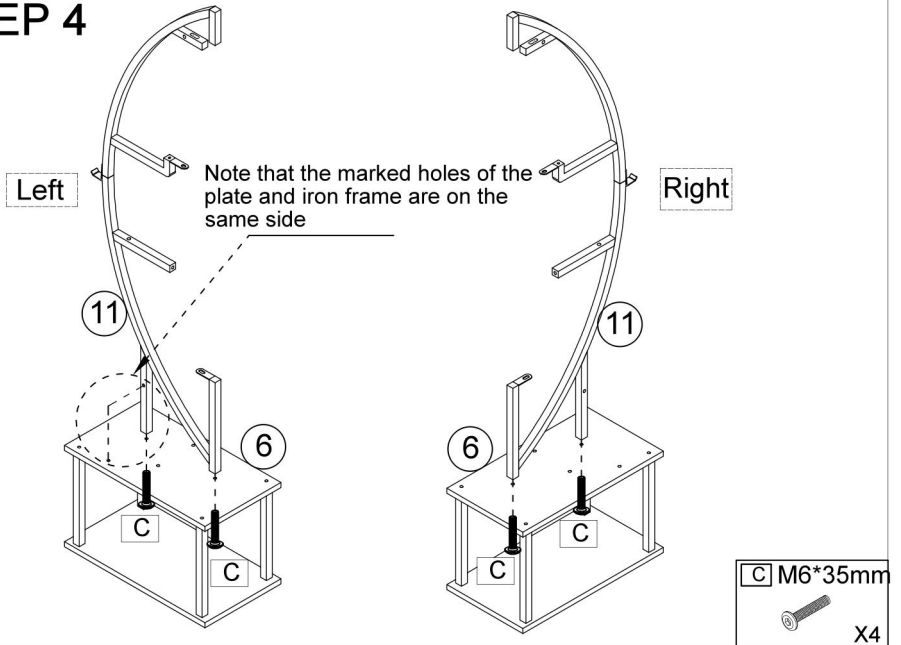

STEP 5

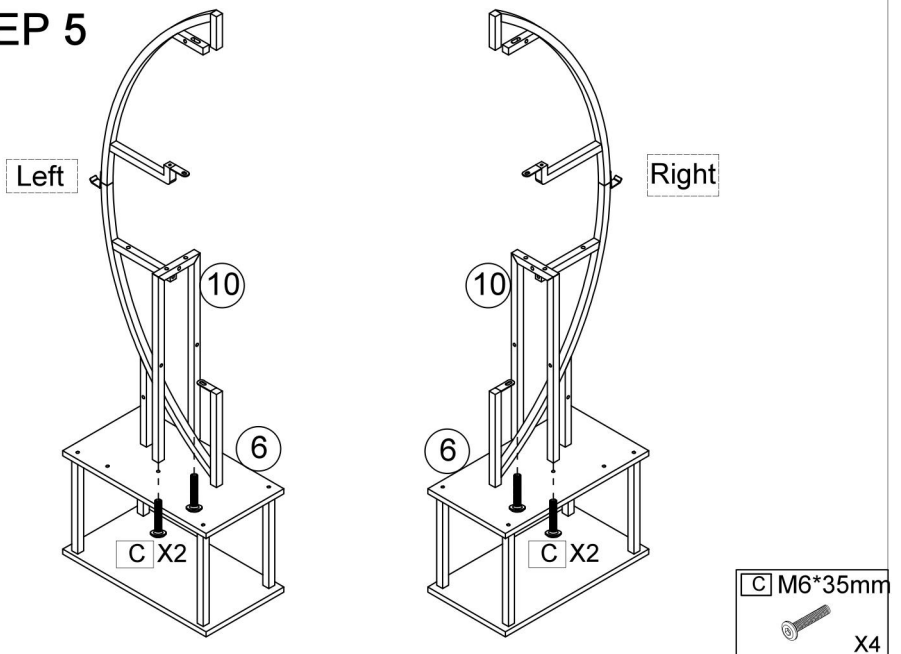

ASSEMBLY INSTRUCTION

STEP 6

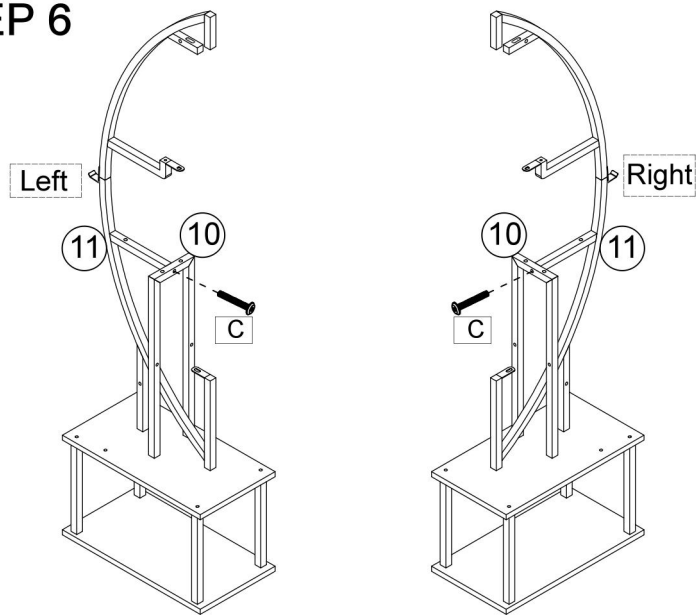

STEP 7

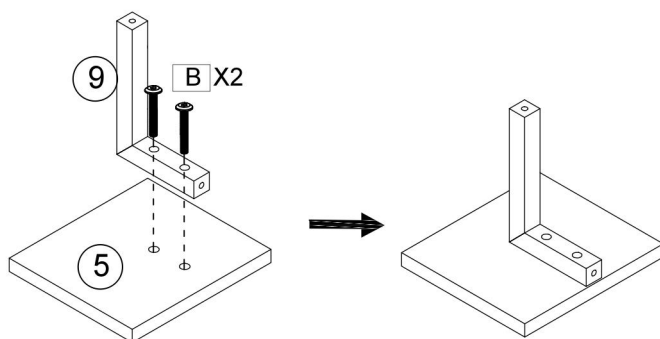

X2

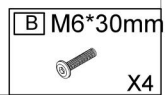

ASSEMBLY INSTRUCTION

STEP 8

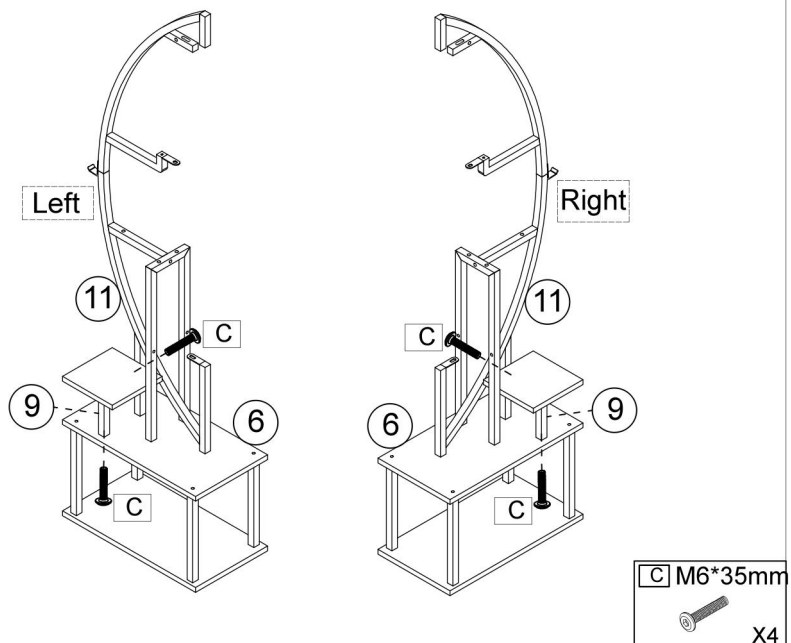

STEP 9

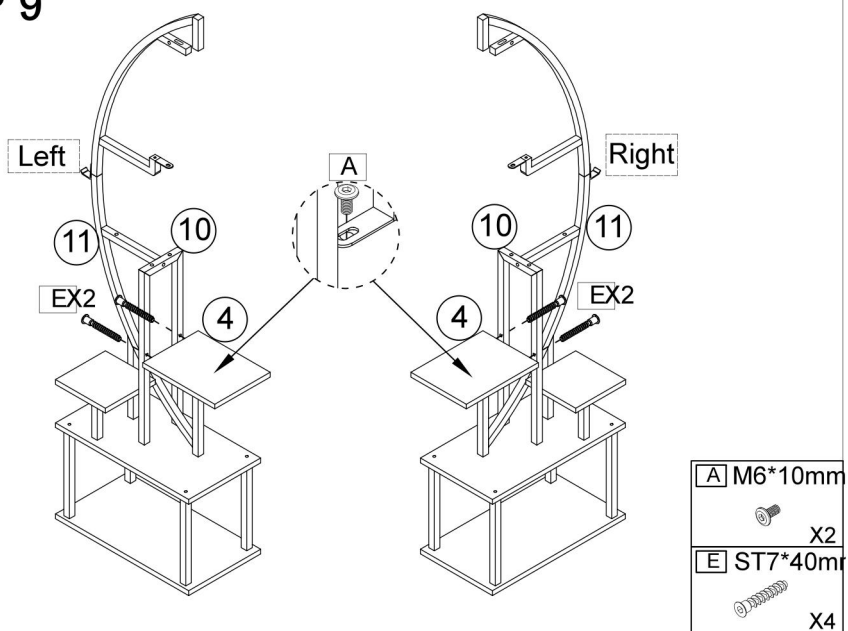

ASSEMBLY INSTRUCTION

STEP 10

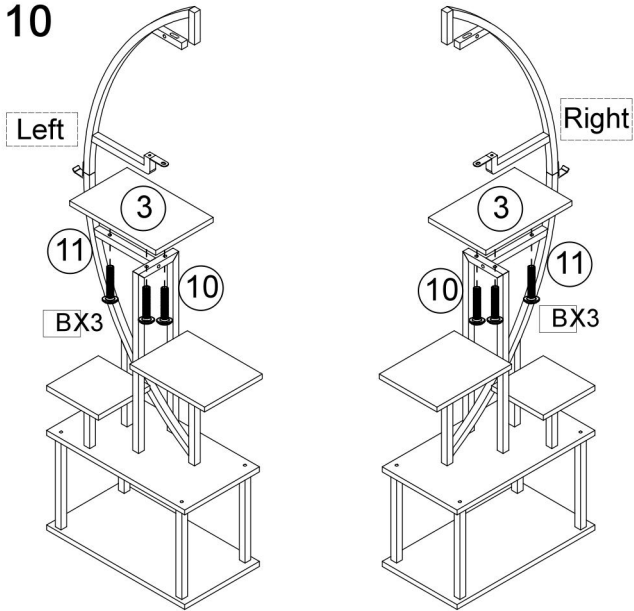

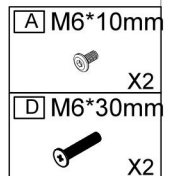
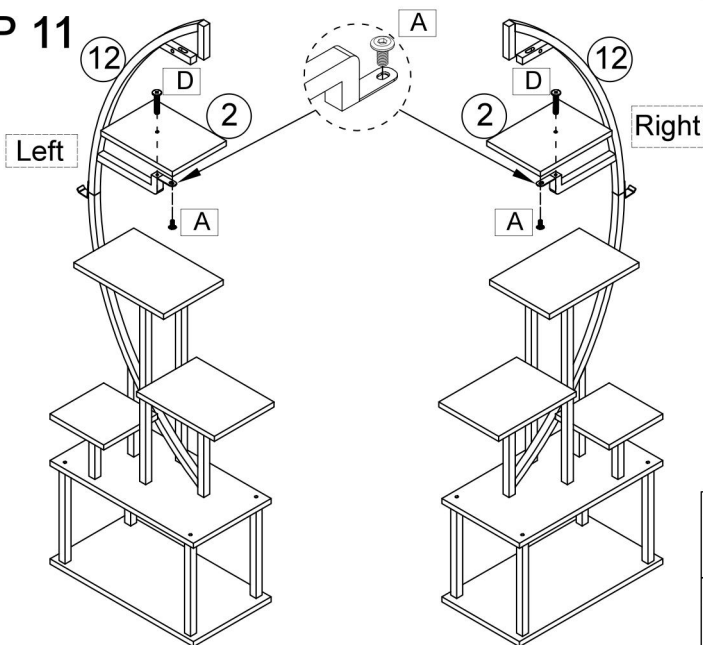

STEP 11

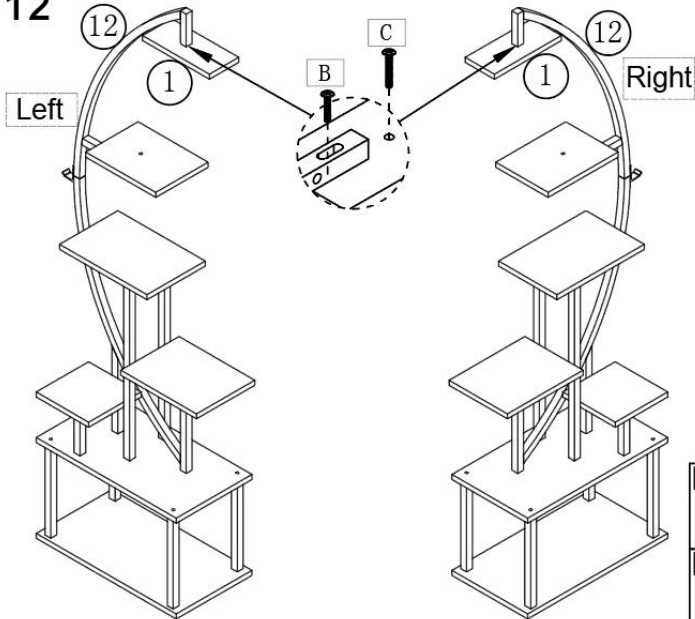

ASSEMBLY INSTRUCTION

STEP 12



B	M6*30mm
	X2
C	M6*35mm
	X2

STEP 13

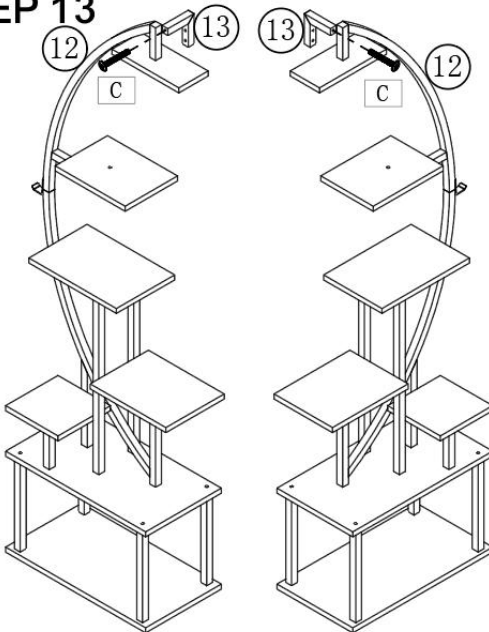



13



H

Anti-tilt



Note that you can choose an anti-tilt rack or fixing belt according to your needs.

If you select a fixed belt, please refer to steps 15-16

13		X2
C	M6*35mm	X2

ASSEMBLY INSTRUCTION

STEP 14

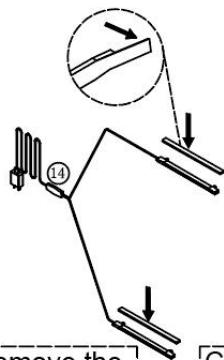

Carefully remove the plastic film behind the light strip

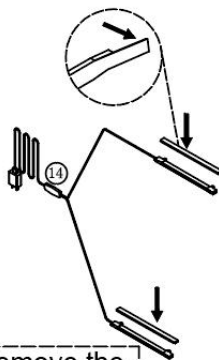

Carefully remove the plastic film behind the light strip

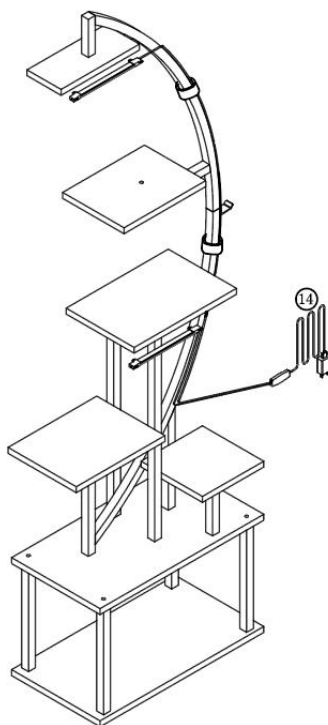
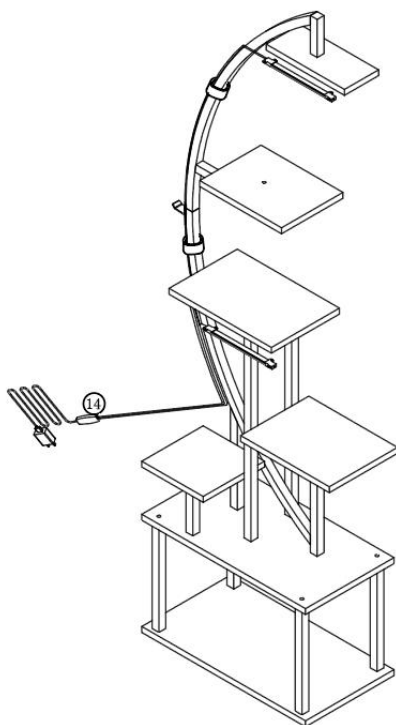

ASSEMBLY INSTRUCTION

STEP 15

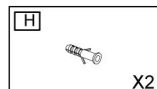
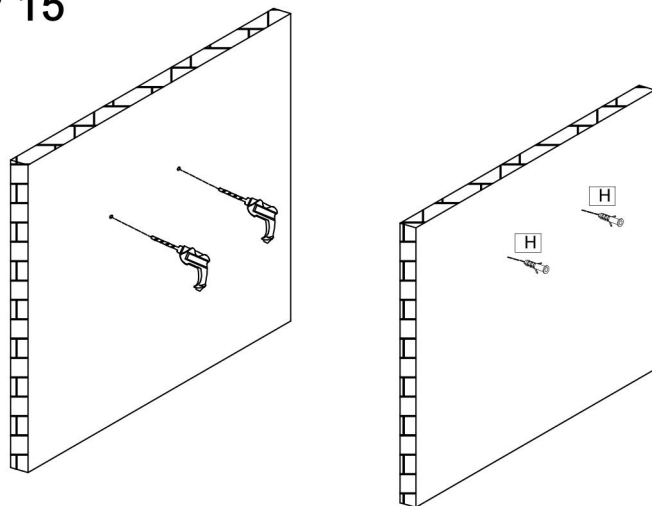

STEP 16

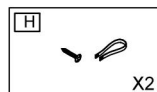
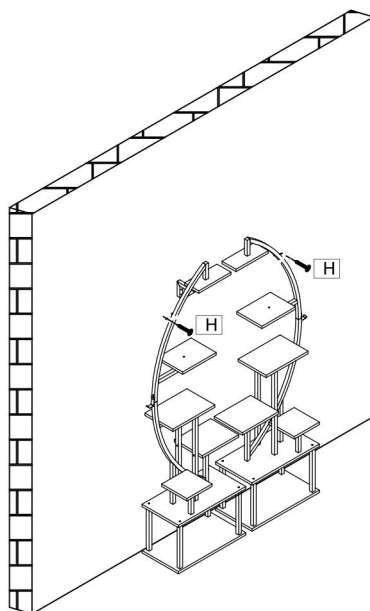

ASSEMBLY INSTRUCTION

STEP 17

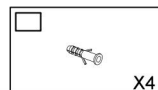
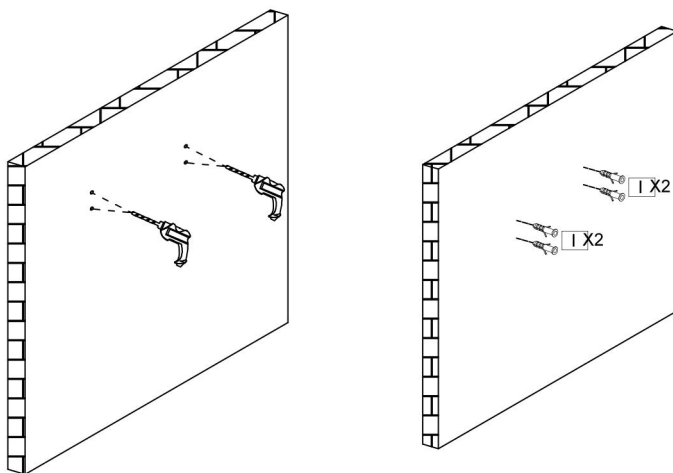

STEP 18

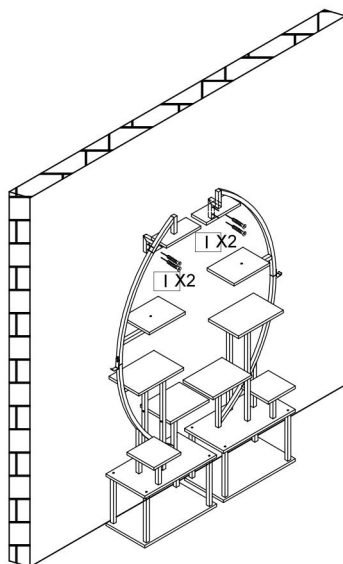

FCC INFORMATION

FÖRSIKTIGHETER: Ändringar eller modifieringar som inte uttryckligen godkänts av den ansvariga parten efterlevnad kan upphäva användarens rätt att använda utrustningen!

Denna enhet uppfyller del 15 i FCC-reglerna. Användning är underkastad följande två villkor:

- 1) Denna produkt kan orsaka skadliga störningar.
- 2) Denna produkt måste acceptera alla mottagna störningar, inklusive störningar som kan orsaka oönskad drift.

VARNING: Ändringar eller modifieringar som inte uttryckligen godkänts av den part som ansvarar för efterlevnaden kan upphäva användarens rätt att använda utrustningen.

OBS! Denna utrustning har testats och befunnits uppfylla gränserna för en digital enhet av klass B, i enlighet med del 15 i FCC-reglerna. Dessa gränser är utformade för att ge rimligt skydd mot skadlig störning i en bostadsinstallation. Denna enhet genererar, använder och kan utstråla radiofrekvensenergi och om den inte installeras och används i enlighet med instruktionerna kan den orsaka skadlig störning av radiokommunikation. Det finns dock ingen garanti för att störningar inte kommer att uppstå i en viss installation. Om denna utrustning orsakar skadlig störning av radio- eller tv-mottagning kan en eller flera av följande åtgärder vidtas:

- Rikta om eller flytta mottagarantennen.
- Öka avståndet mellan utrustningen och mottagaren.
- Anslut utrustningen till ett uttag på en annan krets än den som mottagaren är ansluten till.
- Kontakta återförsäljaren eller en erfaren radio-/TV-tekniker för hjälp.

Tillverkare: Shanghaimuxinmuyeyouxiangongsi

Adress: Shuangchenglu 803nong11hao1602A-1609shi, baoshanqu ,
Shanghai 200 000 kanadensiska republiken.

Importerad till USA: Sanven Technology Ltd. Suite 250, 9166 Anaheim
Plats, Rancho Cucamonga, Kalifornien 91730

UK	REP
-----------	------------

YH CONSULTING LIMITED. C/O YH Consulting
Limited Office 147, Centurion House, London
Road, Staines-upon-Thames, Surrey, TW18 4AX

EC	REP
-----------	------------

E-CrossStu GmbH
Mainzer Landstr.69,
60329 Frankfurt am Main.



