

Park Benches

Park Benches



YQ-062



YQ-128

INSTRUCTIONS

Thank you very much for choosing this Park Benches.

- Please read all of the instructions before using it. The information will help you achieve the best possible results.

The products carried in this catalog may be different in color than the actual item.

WARNING:

1. Operate in a safe work environment. Keep your work area clean, well-lit, and free of distractions.
2. Wear heavy-duty work gloves during assembly.
3. Over-loading is strictly forbidden.



MODEL AND PARAMETERS

Model	YQ-062	YQ-128
Size	50inch	48inch
Rating loading	800lbs /363kg	700lbs / 318kg

ASSEMBLY AND USE

Park bench which used wood: Consisting of a seat frame, seat panel, backrest, and armrests etc.,

HARDWARE LIST

<p>A</p>  <p>18PCS</p>	<p>B</p>  <p>2PCS</p>	<p>C</p>  <p>1PCS</p>
---	--	--

PARTS LIST









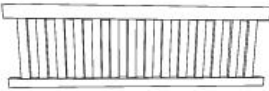

<p>①</p>  <p>1PCS</p>		<p>②</p>  <p>1PCS</p>	
<p>③</p>  <p>1PCS</p>	<p>④</p>  <p>1PCS</p>	<p>⑤</p>  <p>1PCS</p>	<p>⑥</p>  <p>1PCS</p>
<p>⑦</p>  <p>1PCS</p>	<p>⑧</p>  <p>1PCS</p>	<p>⑨</p>  <p>2PCS</p>	<p>⑩</p>  <p>2PCS</p>

Figure 1-1

- ① Backrest *1 ②. Seat board * 1 ③. Left handrail* 1
 ④. Right handrail* 1 ⑤. Left hind leg*1 ⑥. right hind leg*1
 ⑦. left front leg*1 ⑧. right front leg*1 ⑨. Upper connection wood*2
 ⑩. Lower connection wood *2

ASSEMBLY STEPS NOTE:

Leave bolts half-tightened on the bench during assembly until the unit is assembled, then finish tightening bolts ·

STEP 1: Locked screw A and B into legs as below figure1-2.

Step 1

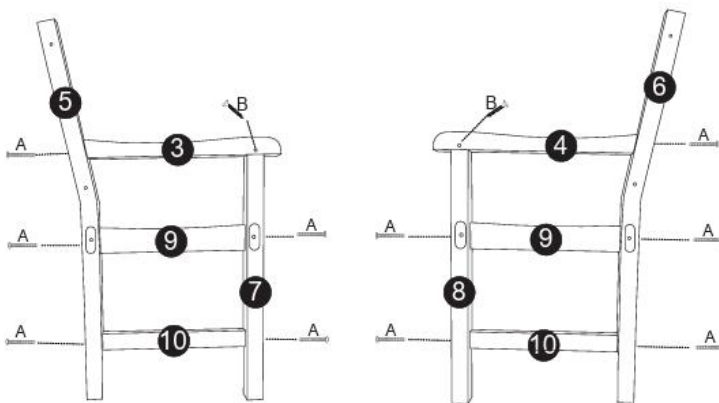

Figure 1-2

STEP 2: Attach seat plate to above left and right handrail assembly with 4 screw A.

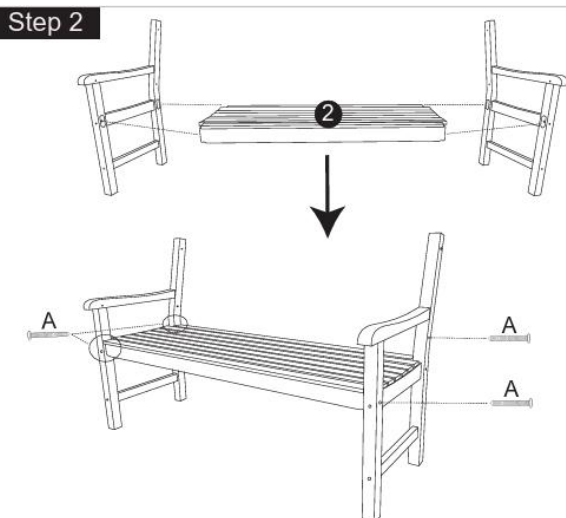

Figure 1-3

STEP 3: Attach backrest (C) to Left leg and right leg with 4 screw A.

Step 3

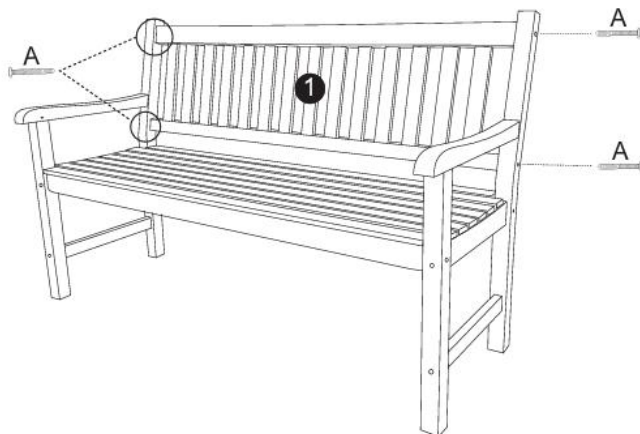

Figure 1-4

Maintenance

1. Check screw fastening regularly.

Manufacturer:Shanghaimuxinmuyeyouxiangongsi

Address: Shuangchenglu 803nong11hao1602A-1609shi, baoshanqu, shanghai 200000 CN.

Imported to AUS: SIHAO PTY LTD. 1 ROKEVA STREETEASTWOOD NSW 2122 Australia

Imported to USA: Sanven Technology Ltd. Suite 250, 9166 Anaheim Place, Rancho Cucamonga, CA 91730

UK	REP
-----------	------------

E-CrossStu GmbH

Mainzer Landstr.69, 60329 Frankfurt am Main.

EC	REP
-----------	------------

YH CONSULTING LIMITED.

C/O YH Consulting Limited Office 147, Centurion House,
London Road, Staines-upon-Thames, Surrey, TW18 4AX

Parkbanken

Park Benches



YQ-062



YQ-128

INSTRUCTIONS

Hartelijk dank dat u voor deze parkbanken heeft gekozen .

- Lees alle instructies voordat u het gebruikt. De informatie zal u helpen de best mogelijke resultaten te bereiken.

De producten in deze catalogus kunnen qua kleur afwijken van het daadwerkelijke artikel .

WAARSCHUWING:

2. Werken in een veilige werkomgeving. Houd uw werkplek schoon, goed verlicht en vrij van afleiding.
2. Draag tijdens de montage stevige werkhandschoenen.
4. Overbelasting is ten strengste verboden.



MODEL AND PARAMETERS

Model	YQ-062	YQ-128
Maat	50 inch	48 inch
Beoordeling laden	800 pond/363 kg	700 pond / 318 kg









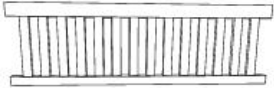

ASSEMBLY AND USE

Parkbank waarin hout is gebruikt: Bestaande uit een zitframe, zitpaneel, rugleuning en armleuningen etc.,

HARDWARE LIST

<p>A</p>  <p>18PCS</p>	<p>B</p>  <p>2PCS</p>	<p>C</p>  <p>1PCS</p>
---	--	--

PARTS LIST

<p>①</p>  <p>1PCS</p>	<p>②</p>  <p>1PCS</p>		
<p>③</p>  <p>1PCS</p>	<p>④</p>  <p>1PCS</p>	<p>⑤</p>  <p>1PCS</p>	<p>⑥</p>  <p>1PCS</p>
<p>⑦</p>  <p>1PCS</p>	<p>⑧</p>  <p>1PCS</p>	<p>⑨</p>  <p>2PCS</p>	<p>⑩</p>  <p>2PCS</p>

Figuur 1-1

- ① Rugleuning *1 ② . Zitplank * 1 ③. Linker leuning * 1
 ④ . Rechter leuning * 1 ⑤. Linkerachterpoot*1 ⑥. rechter achterbeen*1
 ⑦. linker voorpoot*1 ⑧. rechter voorpoot*1 ⑨. Bovenste verbinding hout*2
 ⑩. Onderste aansluiting hout *2

MONTAGESTAPPEN OPMERKING:

Laat de bouten tijdens de montage half aangedraaid op de bank zitten totdat de unit staat gemonteerd en voltooi vervolgens het aandraaien van de bouten ·

STAP 1: Vergrendel schroef A en B in de poten, zoals hieronder in afbeelding 1-2.

Step 1

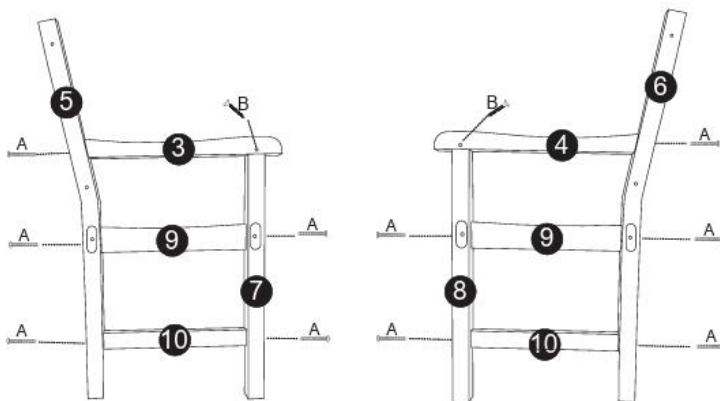

Figuur 1-2

STAP 2: Bevestig de zitplaat aan de linker en rechter leuningconstructie boven met 4 schroeven A.

Step 2

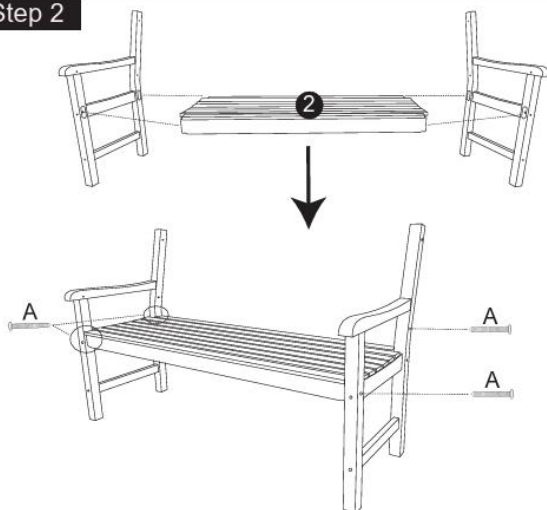

Figuur 1-3

STAP 3: Bevestig de rugleuning (C) aan o Linkerbeen en rechterbeen met 4 schroeven A.

Step 3

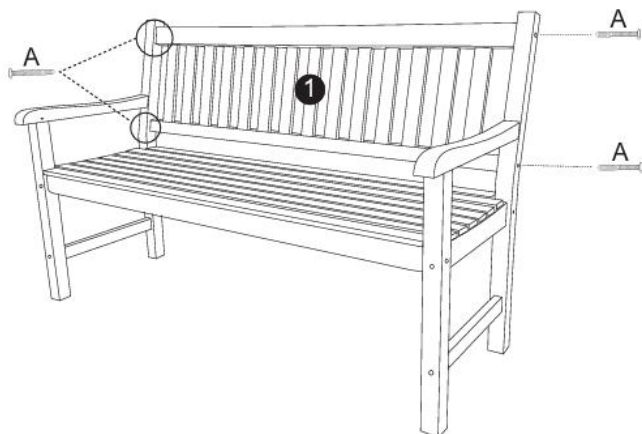

Figuur 1-4

Onderhoud

1. Controleer de schroefbevestiging regelmatig.

Fabrikant : Shanghai muxinmuyeyouxiangongsi

Adres: Shuangchenglu 803nong11hao1602A-1609shi, baoshanqu, shanghai 200000 CN.

Geïmporteerd naar AUS: SIHAO PTY LTD. 1 ROKEVA
STREETEASTWOOD NSW 2122 Australië

Geïmporteerd in de VS: Sanven Technology Ltd. Suite 250, 9166
Anaheim

Plaats, Rancho Cucamonga, CA 91730



E-CrossStu GmbH

Mainzer Landstr.69, 60329 Frankfurt am Main.



YH CONSULTING LIMITED.

C/O YH Consulting Limited Office 147, Centurion House,
London Road, Staines-upon-Thames, Surrey, TW18 4AX

Park bänkar

Park Benches



YQ-062



YQ-128

INSTRUCTIONS

Tack så mycket för att du valde denna parkbänk .

- Läs alla instruktioner innan du använder den. Informationen hjälper dig att uppnå bästa möjliga resultat.

Produkterna i denna katalog kan ha en annan färg än den faktiska varan .

VARNING:

3. Arbeta i en säker arbetsmiljö. Håll ditt arbetsområde rent, väl upplyst och fritt från distraktioner.
2. Använd kraftiga arbetshandskar vid montering.
5. Överbelastning är strängt förbjudet.



MODEL AND PARAMETERS

Modell	YQ-062	YQ-128
Storlek	50 tum	48 tum
Betyg laddas	800 lbs / 363 kg	700 lbs / 318 kg

ASSEMBLY AND USE

Parkbänk som använde trä: Bestående av en sitsram, sittpanel, ryggstöd och armstöd etc.,

HARDWARE LIST

<p>A</p>  <p>18PCS</p>	<p>B</p>  <p>2PCS</p>	<p>C</p>  <p>1PCS</p>
---	--	--

PARTS LIST









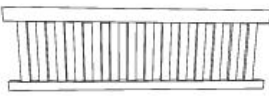

<p>①</p>  <p>1PCS</p>		<p>②</p>  <p>1PCS</p>	
<p>③</p>  <p>1PCS</p>	<p>④</p>  <p>1PCS</p>	<p>⑤</p>  <p>1PCS</p>	<p>⑥</p>  <p>1PCS</p>
<p>⑦</p>  <p>1PCS</p>	<p>⑧</p>  <p>1PCS</p>	<p>⑨</p>  <p>2PCS</p>	<p>⑩</p>  <p>2PCS</p>

Bild 1-1

- ① Ryggstöd *1 ② . Sittbräda * 1 ③. Vänster ledstång * 1
 ④ . Höger ledstång * 1 ⑤. Vänster bakben*1 ⑥. höger bakben*1
 ⑦. vänster framben*1 ⑧. höger framben*1 ⑨. Övre anslutningsträ*2
 ⑩. Nedre anslutningsträ *2

MONTERINGSSEG OBS:

Låt bultarna vara halvåtdragna på bänken under monteringen tills enheten är monterad och dra sedan åt bultarna ·

STEG 1: Låsta skruven A och B i benen enligt figur 1-2.

Step 1



Bild 1-2

STEG 2: Fäst sittplattan ovanför vänster och höger ledstångsenhet med 4 skruvar A.

Step 2

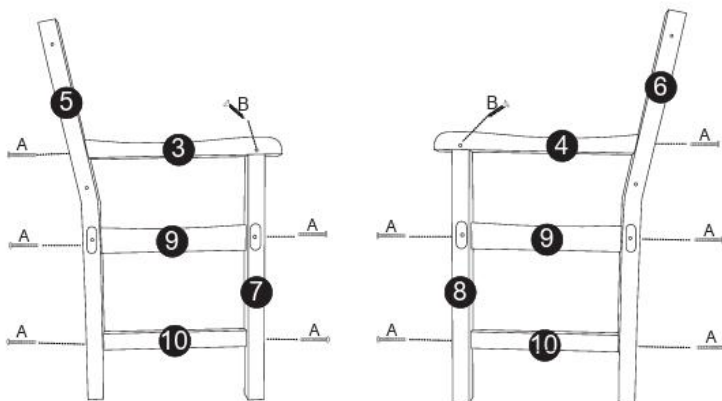

Bild 1-3

STEG 3: Fäst ryggstödet (C) t o Vänster ben och höger ben med 4 skruvar A.

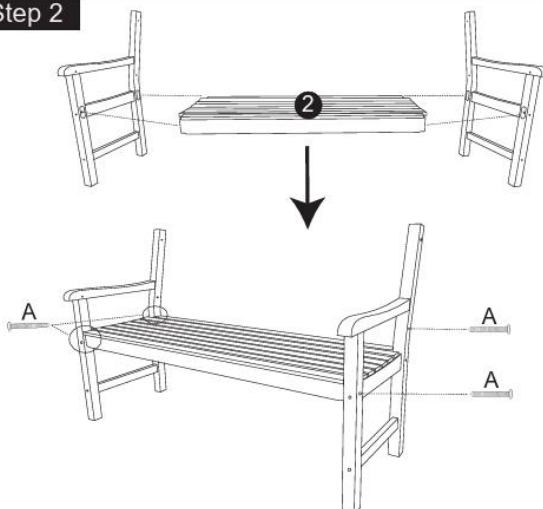

Bild 1-4

Underhåll

1. Kontrollera regelbundet skruvarna.

Tillverkare : Shanghaimuxinmuyeyouxiangongsi

Adress: Shuangchenglu 803nong11hao1602A-1609shi, baoshanqu, shanghai 200000 CN.

Importerad till AUS: SIHAO PTY LTD. 1 ROKEVA STREETEASTWOOD NSW 2122 Australien

Importerad till USA: Sanven Technology Ltd. Suite 250, 9166 Anaheim Place, Rancho Cucamonga, CA 91730

UK	REP
-----------	------------

E-CrossStu GmbH

Mainzer Landstr.69, 60329 Frankfurt am Main.

EC	REP
-----------	------------

YH CONSULTING LIMITED.

C/O YH Consulting Limited Office 147, Centurion House, London Road, Staines-upon-Thames, Surrey, TW18 4AX

Bancos del parque

Park Benches



YQ-062



YQ-128

INSTRUCTIONS

Muchas gracias por elegir estos bancos del parque .

- Lea todas las instrucciones antes de usarlo. La información le ayudará a conseguir los mejores resultados posibles.

Los productos incluidos en este catálogo pueden tener un color diferente al del artículo real .

ADVERTENCIA:

4. Operar en un ambiente de trabajo seguro. Mantenga su área de trabajo limpia, bien iluminada y libre de distracciones.
2. Utilice guantes de trabajo resistentes durante el montaje.
6. Está estrictamente prohibida la sobrecarga.



MODEL AND PARAMETERS

Modelo	YQ-062	YQ-128
Tamaño	50 pulgadas	48 pulgadas
Carga de calificación	800 libras/363 kg	700 libras / 318 kg

ASSEMBLY AND USE

Banco de parque de madera: compuesto por estructura de asiento, panel de asiento, respaldo y reposabrazos, etc.

HARDWARE LIST

<p>A</p>  <p>18PCS</p>	<p>B</p>  <p>2PCS</p>	<p>C</p>  <p>1PCS</p>
---	--	--

PARTS LIST









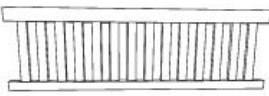

<p>①</p>  <p>1PCS</p>	<p>②</p>  <p>1PCS</p>		
<p>③</p>  <p>1PCS</p>	<p>④</p>  <p>1PCS</p>	<p>⑤</p>  <p>1PCS</p>	<p>⑥</p>  <p>1PCS</p>
<p>⑦</p>  <p>1PCS</p>	<p>⑧</p>  <p>1PCS</p>	<p>⑨</p>  <p>2PCS</p>	<p>⑩</p>  <p>2PCS</p>

Figura 1-1

- ① Respaldo *1 ② . Tablero de asiento * 1 ③. Pasamanos izquierdo * 1
 ④ . Pasamanos derecho * 1 ⑤. Pata trasera izquierda*1 ⑥. pata trasera derecha*1
 ⑦. pata delantera izquierda*1 ⑧. pata delantera derecha*1 ⑨. Madera de

conexión superior*2

⑩. Madera de conexión inferior *2

PASOS DE MONTAJE NOTA:

Deje los pernos medio apretados en el banco durante el montaje hasta que la unidad esté ensamblado , luego termine de apretar los pernos .

PASO 1: Bloquee los tornillos A y B en las patas como se muestra a continuación en la figura 1-2.

Step 1



Figura 1-2

PASO 2: Fije la placa del asiento al conjunto de pasamanos superior izquierdo y derecho con 4 tornillos A.

Step 2

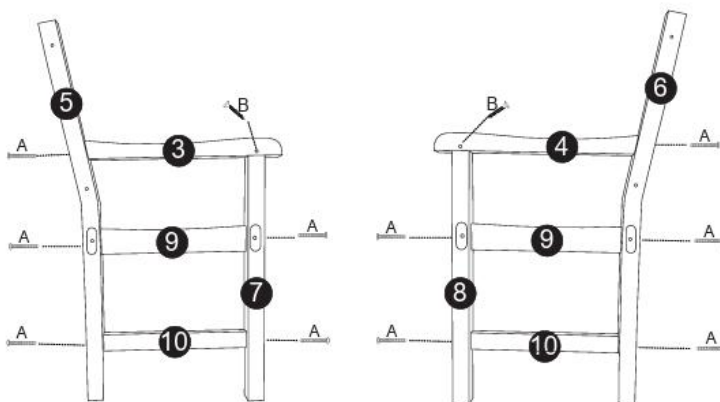

Figura 1-3

PASO 3: Fije el respaldo (C) a Pata izquierda y pata derecha con 4 tornillos A.

Step 3

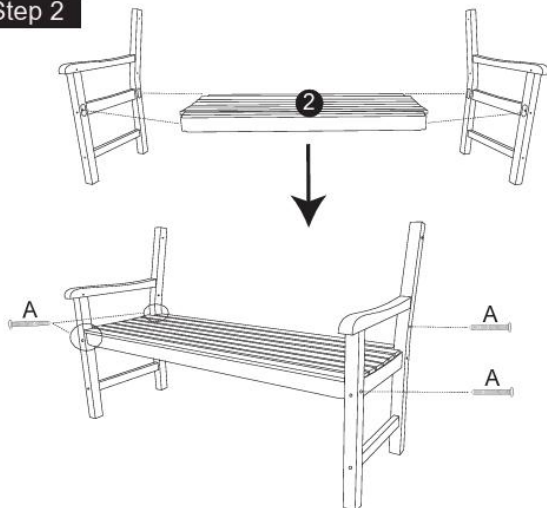

Figura 1-4

Mantenimiento

1. Compruebe periódicamente el ajuste de los tornillos.

Fabricante : Shanghaimuxinmuyeyouxiangongsi

Dirección: Shuangchenglu 803nong11hao1602A-1609shi, baoshanqu, shanghai 200000 CN.

Importado a AUS: SIHAO PTY LTD. 1 ROKEVA STREETASTWOOD
NSW 2122 Australia

Importado a EE. UU.: Sanven Technology Ltd. Suite 250, 9166 Anaheim
Lugar, Rancho Cucamonga, CA 91730



E-CrossStu GmbH
Mainzer Landstr.69, 60329 Frankfurt am Main.



YH CONSULTING LIMITED.
C/O YH Consulting Limited Office 147, Centurion House,
London Road, Staines-upon-Thames, Surrey, TW18 4AX

Panchine del parco

Park Benches



YQ-062



YQ-128

INSTRUCTIONS

Grazie mille per aver scelto queste panchine .

- Si prega di leggere tutte le istruzioni prima di utilizzarlo. Le informazioni ti aiuteranno a ottenere i migliori risultati possibili.

I prodotti presenti in questo catalogo potrebbero differire nel colore rispetto all'articolo reale .

AVVERTIMENTO:

5. Operare in un ambiente di lavoro sicuro. Mantieni la tua area di lavoro pulita, ben illuminata e priva di distrazioni.
2. Indossare guanti da lavoro resistenti durante il montaggio.
7. È severamente vietato sovraccaricare.



MODEL AND PARAMETERS

Modello	YQ-062	YQ-128
Misurare	50 pollici	48 pollici
Caricamento della valutazione	800 libbre/363 kg	700 libbre/318 kg

ASSEMBLY AND USE

Panchina da parco in legno: composta da telaio del sedile, pannello del sedile, schienale, braccioli, ecc.,

HARDWARE LIST

<p>A</p>  <p>18PCS</p>	<p>B</p>  <p>2PCS</p>	<p>C</p>  <p>1PCS</p>
---	--	--

PARTS LIST









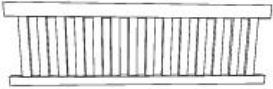

<p>①</p>  <p>1PCS</p>	<p>②</p>  <p>1PCS</p>		
<p>③</p>  <p>1PCS</p>	<p>④</p>  <p>1PCS</p>	<p>⑤</p>  <p>1PCS</p>	<p>⑥</p>  <p>1PCS</p>
<p>⑦</p>  <p>1PCS</p>	<p>⑧</p>  <p>1PCS</p>	<p>⑨</p>  <p>2PCS</p>	<p>⑩</p>  <p>2PCS</p>

Figura 1-1

- ① Schienale *1 ② . Pannello del sedile * 1 ③. Corrimano sinistro * 1
 ④ . Corrimano destro * 1 ⑤. Zampa posteriore sinistra*1 ⑥. zampa posteriore
 destra*1
 ⑦. gamba anteriore sinistra*1 ⑧. gamba anteriore destra*1 ⑨. Legno di

collegamento superiore*2

⑩. Legno di connessione inferiore *2

FASI DI MONTAGGIO NOTA:

Lasciare i bulloni serrati a metà sul banco durante il montaggio finché l'unità non è fissata assemblato , quindi finire di stringere i bulloni .

FASE 1: Bloccare le viti A e B nelle gambe come di seguito nella figura 1-2.

Step 1



Figura 1-2

PASSO 2: Fissare la piastra del sedile al gruppo corrimano sopra sinistro e destro con 4 viti A.

Step 2

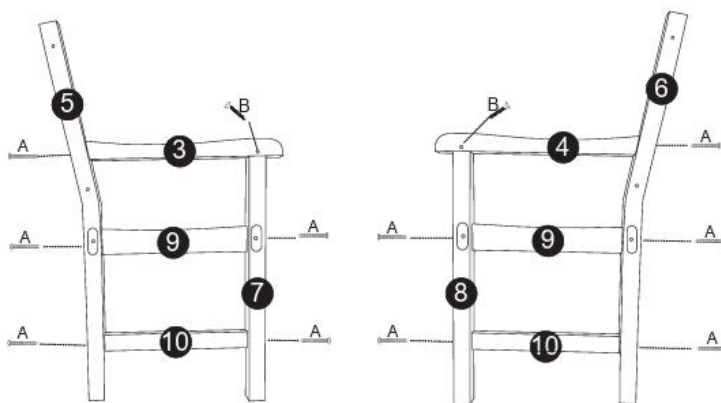

Figura 1-3

PASSO 3: Fissare lo schienale (C) a Gamba sinistra e gamba destra con 4 viti A.

Step 3

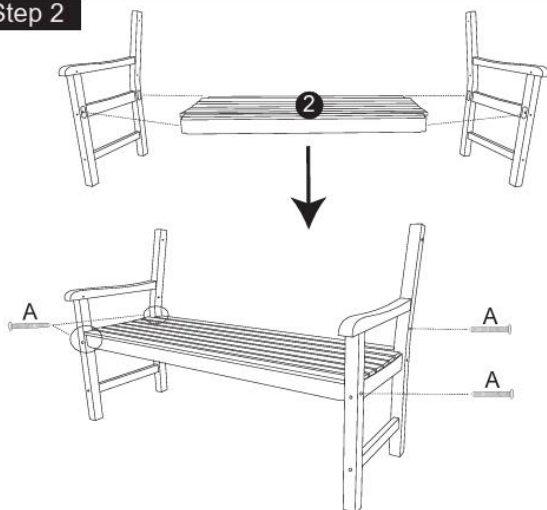

Figura 1-4

Manutenzione

1. Controllare regolarmente il fissaggio delle viti.

Produttore : Shanghaimuxinmuyeyouxiangongsi

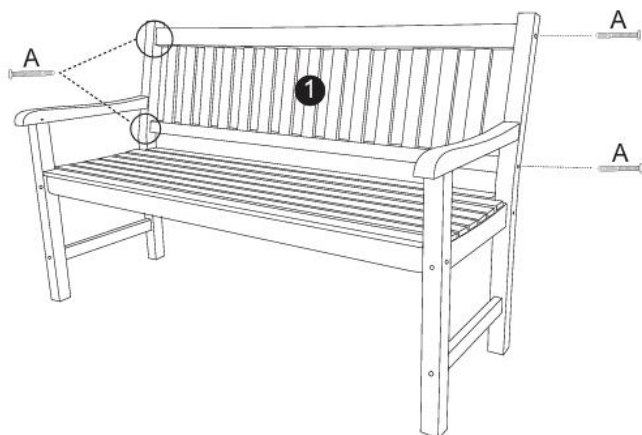
Indirizzo: Shuangchenglu 803nong11hao1602A-1609shi, baoshanqu, shanghai 200000 CN.

Importato in AUS: SIHAO PTY LTD. 1 ROKEVA STREETEASTWOOD NSW 2122 Australia

Importato negli Stati Uniti: Sanven Technology Ltd. Suite 250, 9166 Anaheim

Luogo, Rancho Cucamonga, CA 91730



E-CrossStu GmbH

Mainzer Landstr.69, 60329 Frankfurt am Main.



YH CONSULTING LIMITED.

C/O YH Consulting Limited Office 147, Centurion House,
London Road, Staines-upon-Thames, Surrey, TW18 4AX

Ławki parkowe

Park Benches



YQ-062



YQ-128

INSTRUCTIONS

Dziękujemy bardzo za wybór ławek parkowych .

- Przed użyciem przeczytaj całą instrukcję. Informacje te pomogą Ci osiągnąć najlepsze możliwe rezultaty.

Produkty prezentowane w tym katalogu mogą różnić się kolorem od rzeczywistego .

OSTRZEŻENIE:

6. Pracuj w bezpiecznym środowisku pracy. Utrzymuj miejsce pracy w czystości, dobrze oświetlone i wolne od czynników rozpraszających.
2. Podczas montażu należy nosić grube rękawice robocze.
8. Przeciążanie jest surowo zabronione.



MODEL AND PARAMETERS

Model	YQ-062	YQ-128
ROZMIAR	50 cali	48 cali
Ładowanie ocen	800 funtów / 363 kg	700 funtów / 318 kg









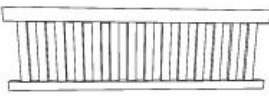

ASSEMBLY AND USE

Ławka parkowa wykonana z drewna: składająca się z ramy siedziska, panelu siedziska, oparcia i podłokietników itp.,

HARDWARE LIST

<p>A</p>  <p>18PCS</p>	<p>B</p>  <p>2PCS</p>	<p>C</p>  <p>1PCS</p>
---	--	--

PARTS LIST

<p>①</p>  <p>1PCS</p>		<p>②</p>  <p>1PCS</p>	
<p>③</p>  <p>1PCS</p>	<p>④</p>  <p>1PCS</p>	<p>⑤</p>  <p>1PCS</p>	<p>⑥</p>  <p>1PCS</p>
<p>⑦</p>  <p>1PCS</p>	<p>⑧</p>  <p>1PCS</p>	<p>⑨</p>  <p>2PCS</p>	<p>⑩</p>  <p>2PCS</p>

Rysunek 1-1

- ① Oparcie *1 ② . Deska siedziskowa * 1 ③. Lewa poręcz * 1
 ④ . Prawa poręcz * 1 ⑤. Lewa tylna noga*1 ⑥. prawa tylna noga*1
 ⑦. lewa przednia noga*1 ⑧. prawa przednia noga*1 ⑨. Górne połączenie drewniane*2

⑩. Dolne połączenie drewniane *2

ETAPY MONTAŻU UWAGA:

pozostawić śruby do połowy dokręcone na stole warsztatowym, aż urządzenie zostanie zamontowane zmontowane, następnie zakończ dokręcanie śrub.

KROK 1: Zablokuj śruby A i B w nogach jak na rysunku 1-2 poniżej.

Step 1

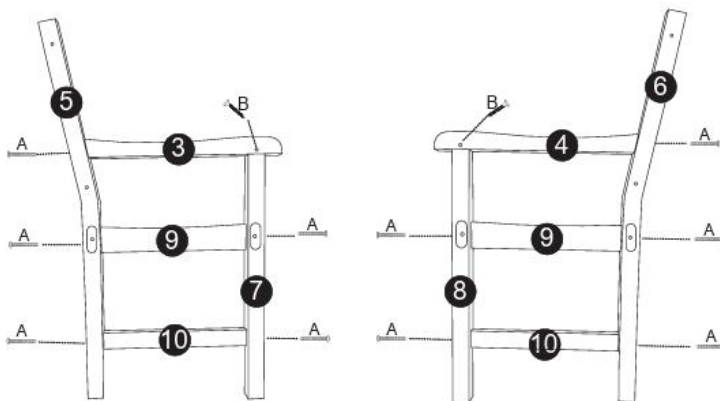

Rysunek 1-2

KROK 2: Przymocuj płytę siedziska do górnej lewej i prawej poręczy za pomocą 4 śrub A.

Step 2

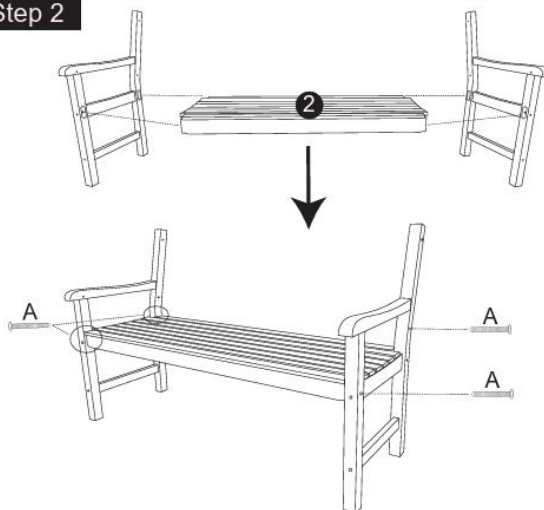

Rysunek 1-3

KROK 3: Przymocuj oparcie (C) do o Lewa i prawa noga z 4 śrubami A.

Step 3

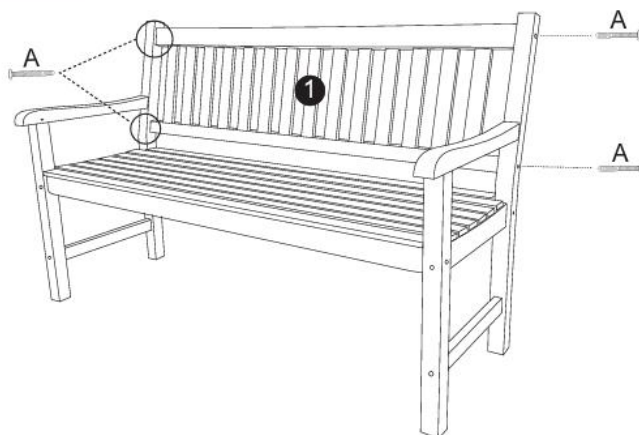

Rysunek 1-4

Konserwacja

1. Regularnie sprawdzaj dokręcenie śrub.

Producent : Shanghaimuxinmuyeyouxiangongsi

Adres: Shuangchenglu 803nong11hao1602A-1609shi, baoshanqu, szanghaj 200000 CN.

Import do AUS: SIHAO PTY LTD. 1 ROKEVA STREETEASTWOOD NSW 2122 Australia

Import do USA: Sanven Technology Ltd. Suite 250, 9166 Anaheim Place, Rancho Cucamonga, Kalifornia 91730

UK	REP
-----------	------------

E-CrossStu GmbH

Mainzer Landstr.69, 60329 Frankfurt am Main.

EC	REP
-----------	------------

YH CONSULTING LIMITED.

C/O YH Consulting Limited Office 147, Centurion House,
London Road, Staines-upon-Thames, Surrey, TW18 4AX

Parkbänke

Park Benches



YQ-062



YQ-128

INSTRUCTIONS

Vielen Dank, dass Sie sich für diese Parkbänke entschieden haben .
- Bitte lesen Sie alle Anweisungen, bevor Sie es verwenden. Die Informationen helfen Ihnen, die bestmöglichen Ergebnisse zu erzielen. Die in diesem Katalog aufgeführten Produkte können farblich vom tatsächlichen Artikel abweichen .

WARNUNG:

7. Arbeiten Sie in einer sicheren Arbeitsumgebung. Halten Sie Ihren Arbeitsbereich sauber, gut beleuchtet und frei von Ablenkungen.
2. Tragen Sie bei der Montage robuste Arbeitshandschuhe.
9. Überladung ist strengstens verboten.



MODEL AND PARAMETERS

Modell		YQ-062	YQ-128
Größe		50 Zoll	48 Zoll
Bewertung geladen	wird	363 kg	318 kg

ASSEMBLY AND USE

Parkbank aus Holz: Bestehend aus Sitzgestell, Sitzplatte, Rückenlehne und Armlehnen etc.,

HARDWARE LIST

<p>A</p>  <p>18PCS</p>	<p>B</p>  <p>2PCS</p>	<p>C</p>  <p>1PCS</p>
---	--	--

PARTS LIST









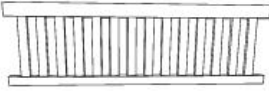

<p>①</p>  <p>1PCS</p>		<p>②</p>  <p>1PCS</p>	
<p>③</p>  <p>1PCS</p>	<p>④</p>  <p>1PCS</p>	<p>⑤</p>  <p>1PCS</p>	<p>⑥</p>  <p>1PCS</p>
<p>⑦</p>  <p>1PCS</p>	<p>⑧</p>  <p>1PCS</p>	<p>⑨</p>  <p>2PCS</p>	<p>⑩</p>  <p>2PCS</p>

Abbildung 1-1

- ① Rückenlehne *1 ② . Sitzbrett * 1 ③. Linker Handlauf * 1
 ④ . Rechter Handlauf * 1 ⑤. Linkes Hinterbein*1 ⑥. rechtes Hinterbein*1
 ⑦. linkes Vorderbein*1 ⑧. rechtes Vorderbein*1 ⑨. Oberes Verbindungsholz*2
 ⑩. Unteres Verbindungsholz *2

MONTAGESCHRITTE HINWEIS:

während des Zusammenbaus auf der Bank halb angezogen, bis das Gerät montiert ist zusammengebaut, dann Schrauben festziehen.

SCHRITT 1: Schrauben Sie A und B wie in Abbildung 1-2 unten in die Beine ein.

Step 1



Abbildung 1-2

SCHRITT 2: Befestigen Sie die Sitzplatte mit 4 Schrauben A an der oberen linken und rechten Handlaufbaugruppe.

Step 2

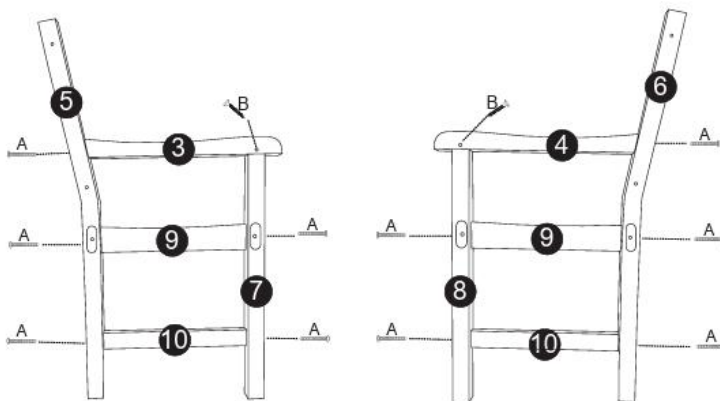

Abbildung 1-3

SCHRITT 3: Befestigen Sie die Rückenlehne (C) daran Linkes Bein und rechtes Bein mit 4 Schrauben A.

Step 3

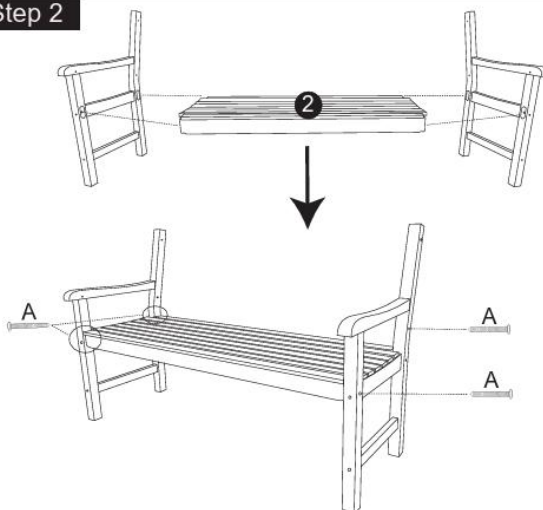

Abbildung 1-4

Wartung

1. Schraubenbefestigung regelmäßig prüfen.

Hersteller : Shanghaimuxinmuyeyouxiangongsi

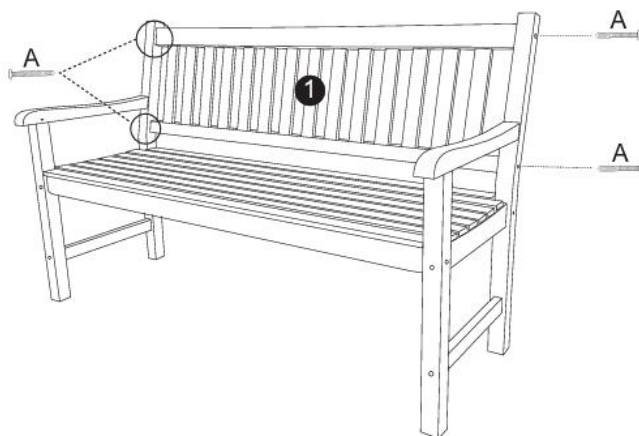
Adresse: Shuangchenglu 803nong11hao1602A-1609shi, baoshanqu, Shanghai 200000 CN.

Importiert nach AUS: SIHAO PTY LTD. 1 ROKEVA STREETEASTWOOD NSW 2122 Australien

In die USA importiert: Sanven Technology Ltd. Suite 250, 9166 Anaheim Place, Rancho Cucamonga, CA 91730



E-CrossStu GmbH

Mainzer Landstr.69, 60329 Frankfurt am Main.



YH CONSULTING LIMITED.

C/O YH Consulting Limited Office 147, Centurion House,
London Road, Staines-upon-Thames, Surrey, TW18 4AX

Bancs de parc

Park Benches



YQ-062



YQ-128

INSTRUCTIONS

Merci beaucoup d'avoir choisi ces bancs de parc .

- Veuillez lire toutes les instructions avant de l'utiliser. Les informations vous aideront à obtenir les meilleurs résultats possibles.

Les produits présentés dans ce catalogue peuvent avoir une couleur différente de celle de l'article réel .

AVERTISSEMENT:

8. Opérez dans un environnement de travail sécuritaire. Gardez votre espace de travail propre, bien éclairé et exempt de distractions.

2. Portez des gants de travail résistants pendant l'assemblage.

10.La surcharge est strictement interdite.



MODEL AND PARAMETERS

Modèle	YQ-062	YQ-128
Taille	50 pouces	48 pouces
Chargement de la note	800 lb /363 kg	700 livres / 318 kg

ASSEMBLY AND USE

Banc de parc en bois : composé d'un cadre de siège, d'un panneau de siège, d'un dossier et d'accoudoirs, etc.,

HARDWARE LIST

<p>A</p>  <p>18PCS</p>	<p>B</p>  <p>2PCS</p>	<p>C</p>  <p>1PCS</p>
---	--	--

PARTS LIST









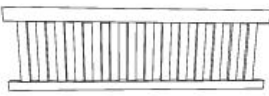

<p>①</p>  <p>1PCS</p>	<p>②</p>  <p>1PCS</p>		
<p>③</p>  <p>1PCS</p>	<p>④</p>  <p>1PCS</p>	<p>⑤</p>  <p>1PCS</p>	<p>⑥</p>  <p>1PCS</p>
<p>⑦</p>  <p>1PCS</p>	<p>⑧</p>  <p>1PCS</p>	<p>⑨</p>  <p>2PCS</p>	<p>⑩</p>  <p>2PCS</p>

Figure 1-1

- ① Dossier *1 ② . Planche de siège * 1 ③. Main courante gauche * 1
 ④ . Main courante droite * 1 ⑤. Patte arrière gauche*1 ⑥. patte arrière droite * 1
 ⑦. jambe avant gauche*1 ⑧. jambe avant droite*1 ⑨. Bois de connexion supérieur*2

⑩. Bois de connexion inférieur *2

ÉTAPES D'ASSEMBLAGE REMARQUE :

Laissez les boulons à moitié serrés sur le banc pendant l'assemblage jusqu'à ce que l'unité soit assemblée, puis terminer le serrage des boulons.

ÉTAPE 1 : Verrouillez les vis A et B dans les pieds comme ci-dessous figure 1-2.

Step 1

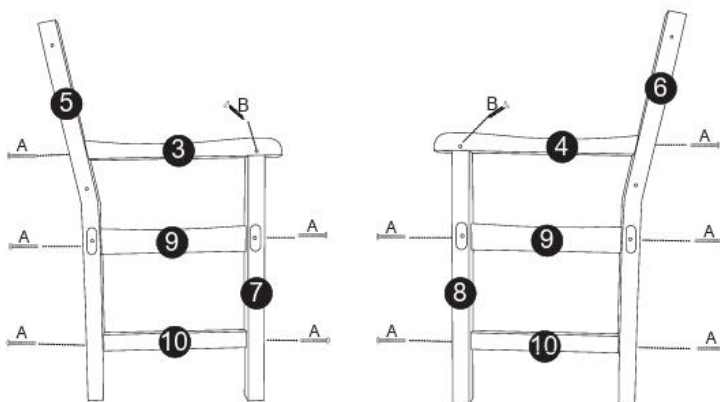

Figure 1-2

ÉTAPE 2: Fixez la plaque de siège à l'ensemble des rampes gauche et droite au-dessus avec 4 vis A.

Step 2

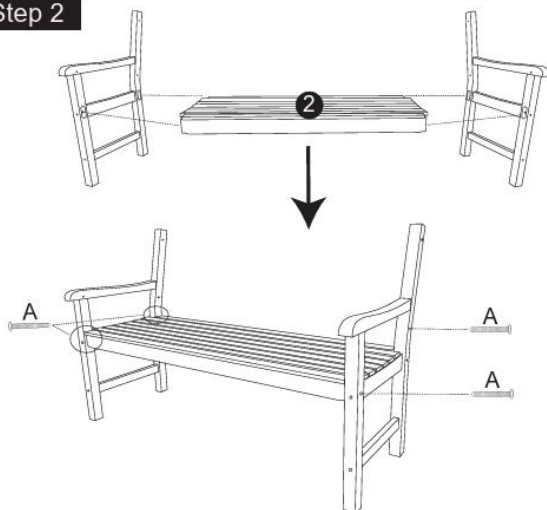

Figure 1-3

ÉTAPE 3: Fixez le dossier (C) à Jambe gauche et jambe droite avec 4 vis A.

Step 3

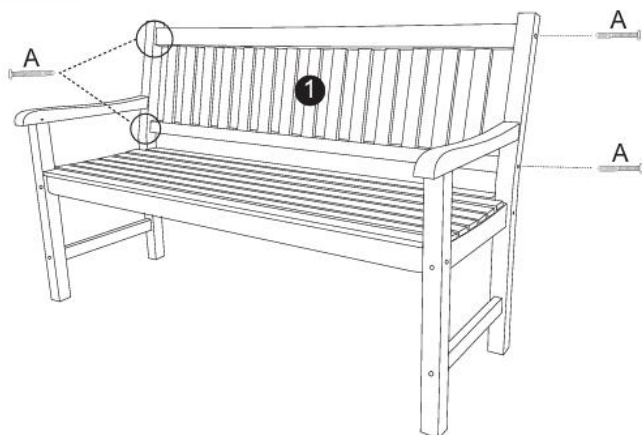

Figure 1-4

Entretien

1. Vérifiez régulièrement le serrage des vis.

Fabricant : Shanghaimuxinmuyeyouxiangongsi

Adresse : Shuangchenglu 803nong11hao1602A-1609shi, baoshanqu,
Shanghai 200000 CN.

Importé en Australie : SIHAO PTY LTD. 1 ROKEVA STREETASTWOOD
NSW 2122 Australie

Importé aux États-Unis : Sanven Technology Ltd. Suite 250, 9166
Anaheim

Lieu, Rancho Cucamonga, CA 91730



E-CrossStu GmbH

Mainzer Landstr.69, 60329 Frankfurt am Main.



YH CONSULTING LIMITED.

C/O YH Consulting Limited Office 147, Centurion House,
London Road, Staines-upon-Thames, Surrey, TW18 4AX

