

**CABINET STYLE WOODEN  
CAT SHELTER  
USER MANUAL**

# CABINET STYLE WOODEN CAT SHELTER

DUSCH2401

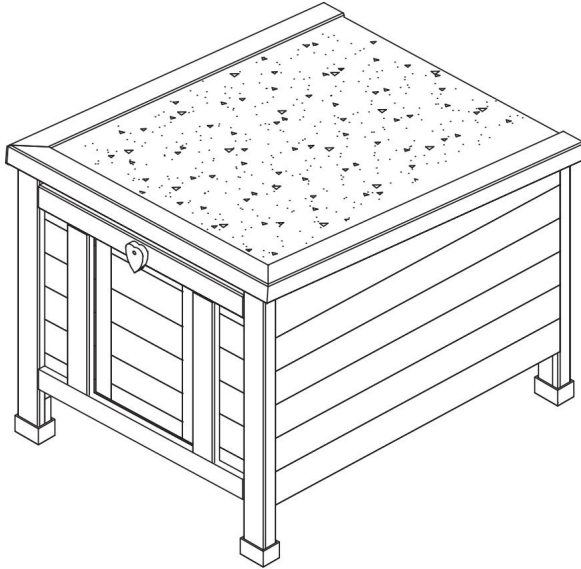

## Safety precautions

### WARNING:

**Read this instructions** before using this product. Failure to do so can result in serious injury. the basic precautions should always be followed,including the following:

1. The Cabinet Style Wooden Cat Shelter may not be used or stored in hazardous areas. It is not allowed to use the appliance in hazardous locations.
2. The Cabinet Style Wooden Cat Shelter must be checked to ensure that it is in proper working order and is operating safely prior to use. Otherwise,the appliance must not be used.
3. Please keep the Kabinestell Wooden Carter Shelter roof closed, otherwise it will cause water ingress.
4. Please clean up the manure and garbage in the house regularly.
5. The operator must use the Cabinet Style Wooden Cat Shelter properly. He must consider the local conditions and must pay attention to third parties,in particular children,when working with the Cabinet Style Wooden Cat Shelter.
6. This Cabinet Style Wooden Cat Shelter is not intended for use by persons (including children) with reduced physical,sensory or mental abilities or lacking experience and/or knowledge,unless they are super- vised by a person responsible for their safety or are instructed by these persons on the use of the

device. Children should be supervised, to ensure that they do not play with the Cabinet Style Wooden Cat Shelter.

## **SAVE THESE INSTRUCTIONS**

### **Product List**

---

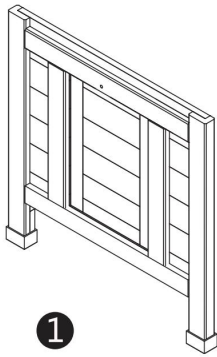

1

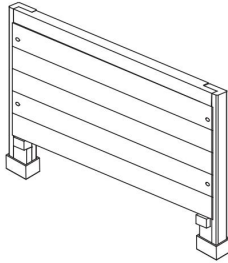

2

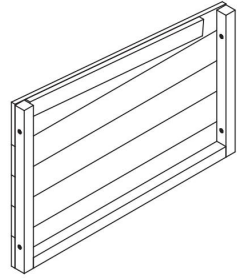

3

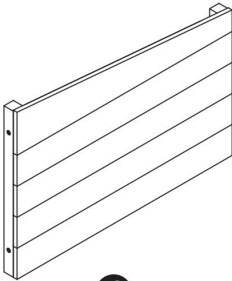

4

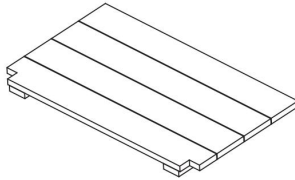

5 X2

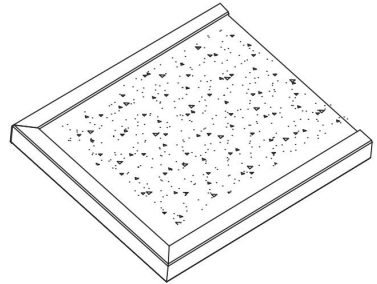

6

(A)  X8  
M6x50

(B)  X8+(1Spare part)  
3.0x16

(C)  X1

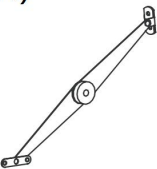
(D)  X1

## Product Assembling

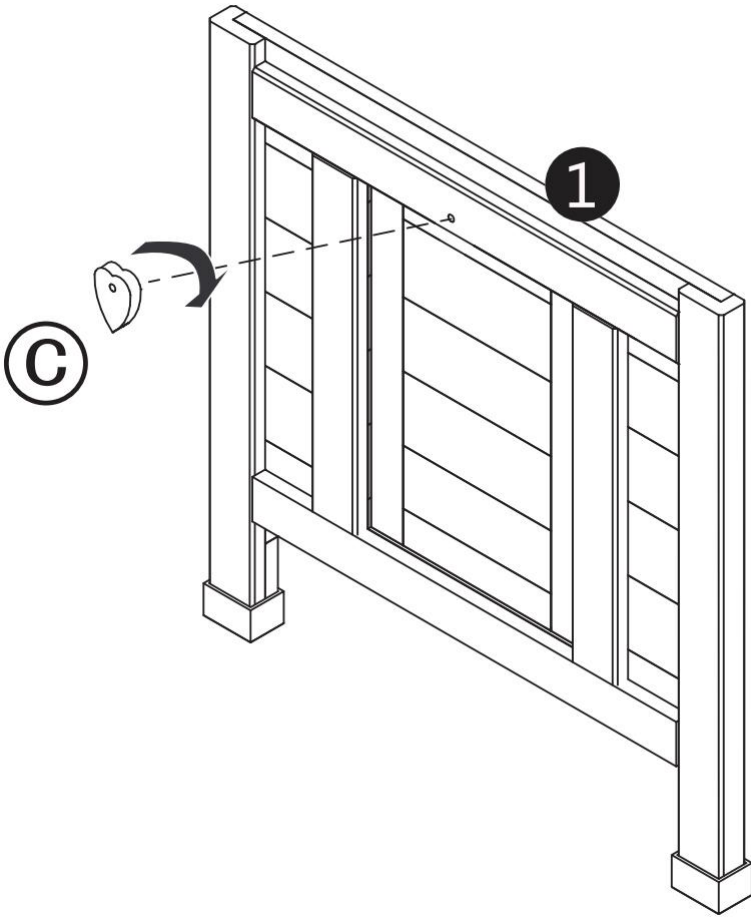

Assemble part C on top of 1.  
Part C controls the opening and closing of the door.

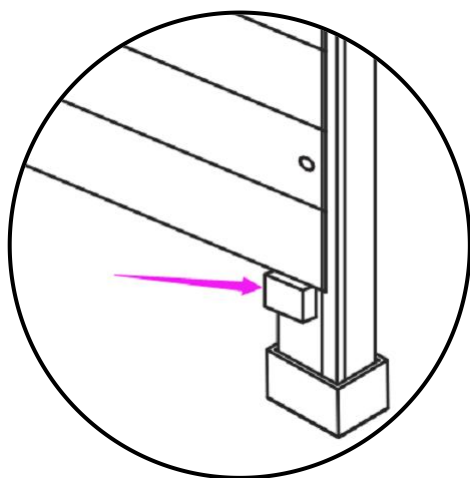
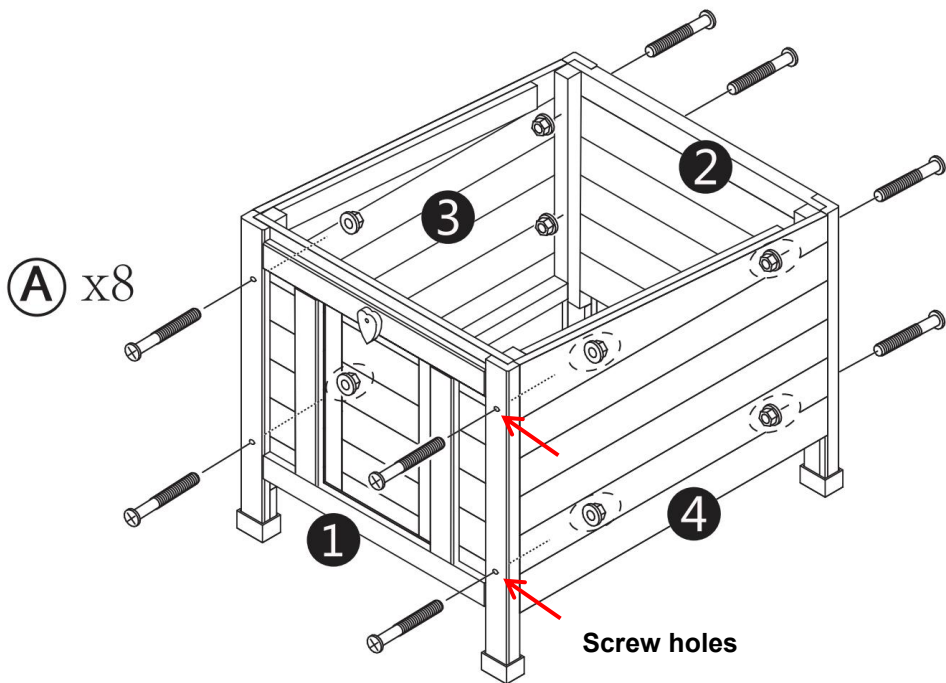

1 2 all have positioning pieces  
can be used and 3 4 for  
positioning assembly.

Assemble and fix (1, 2, 3, and 4) with screws A.

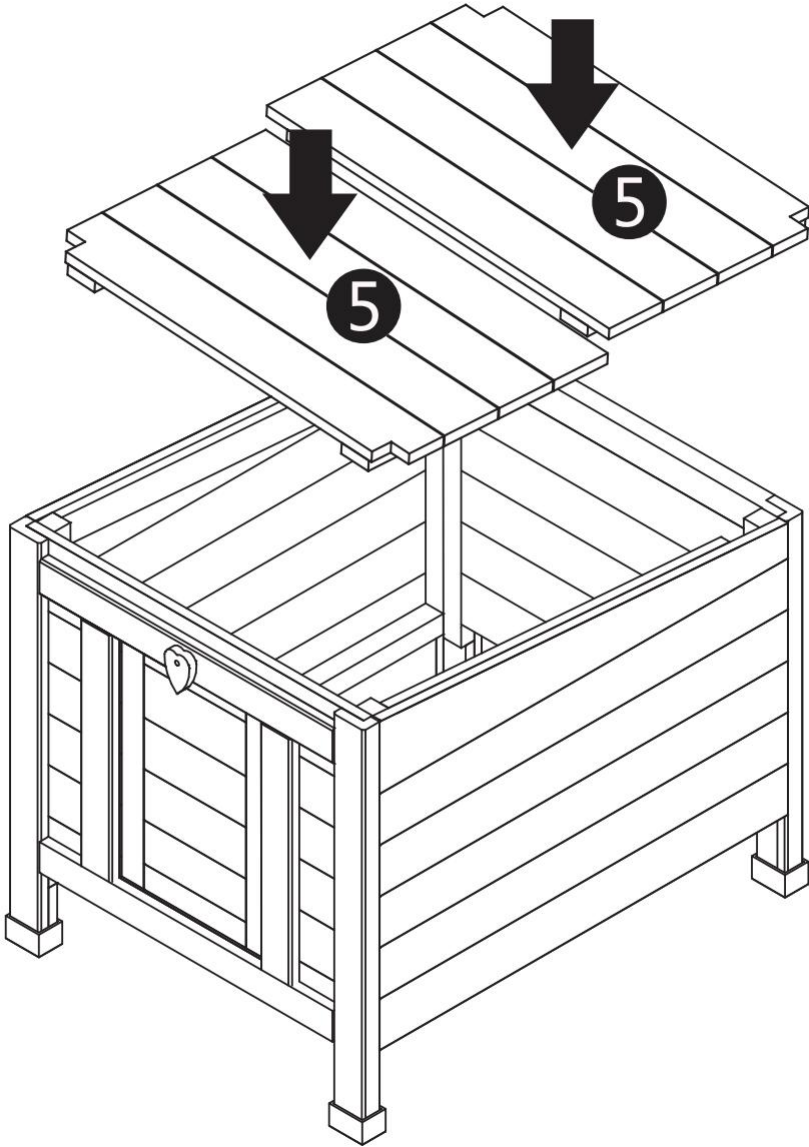

Put 5 in the direction of the arrows.

**Screw position marking**

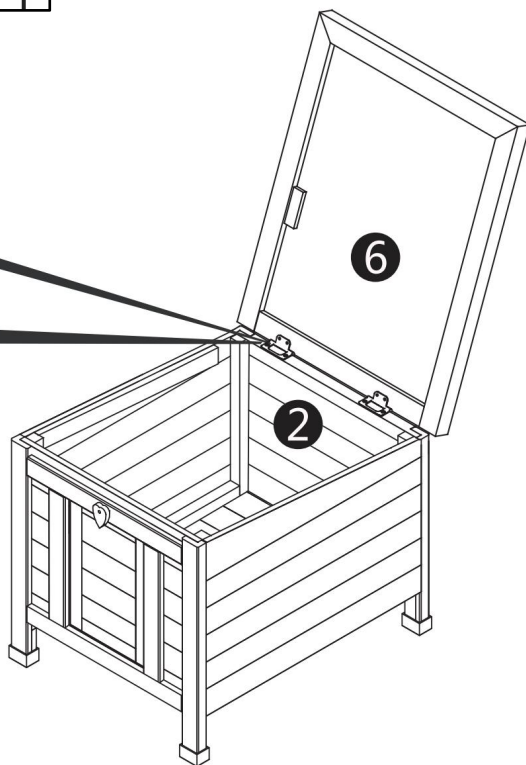
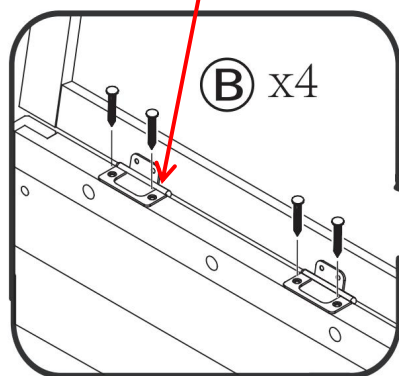
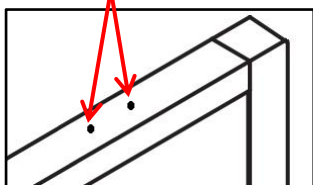

Assemble (8) on the front piece with bolt C.

**Note: For screw installation, align the screw positioning identification points on the side panels.**

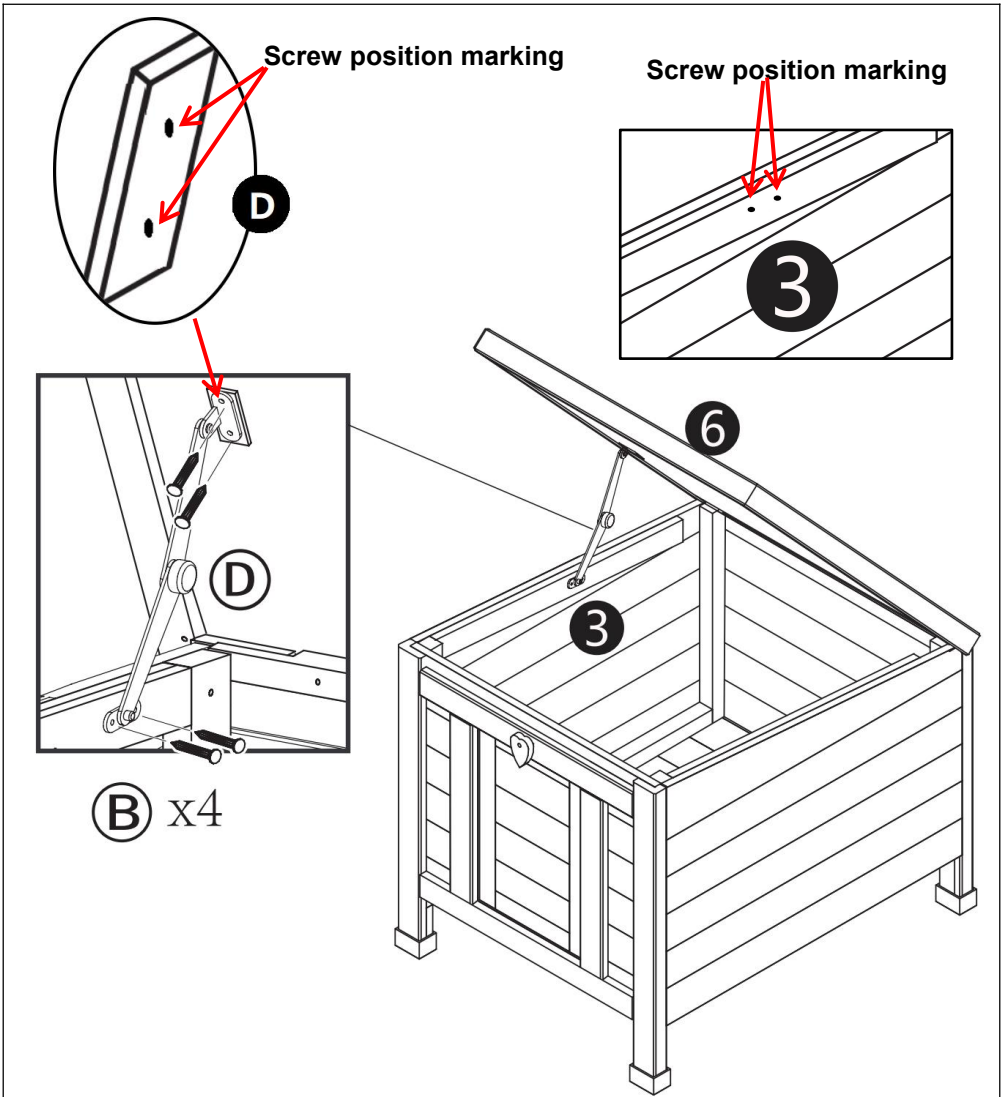

Assemble the two ends of (D) on the roof and the left side sheet with screws B.

**Note:** For screw installation, align the screw positioning identification points on the side panels.

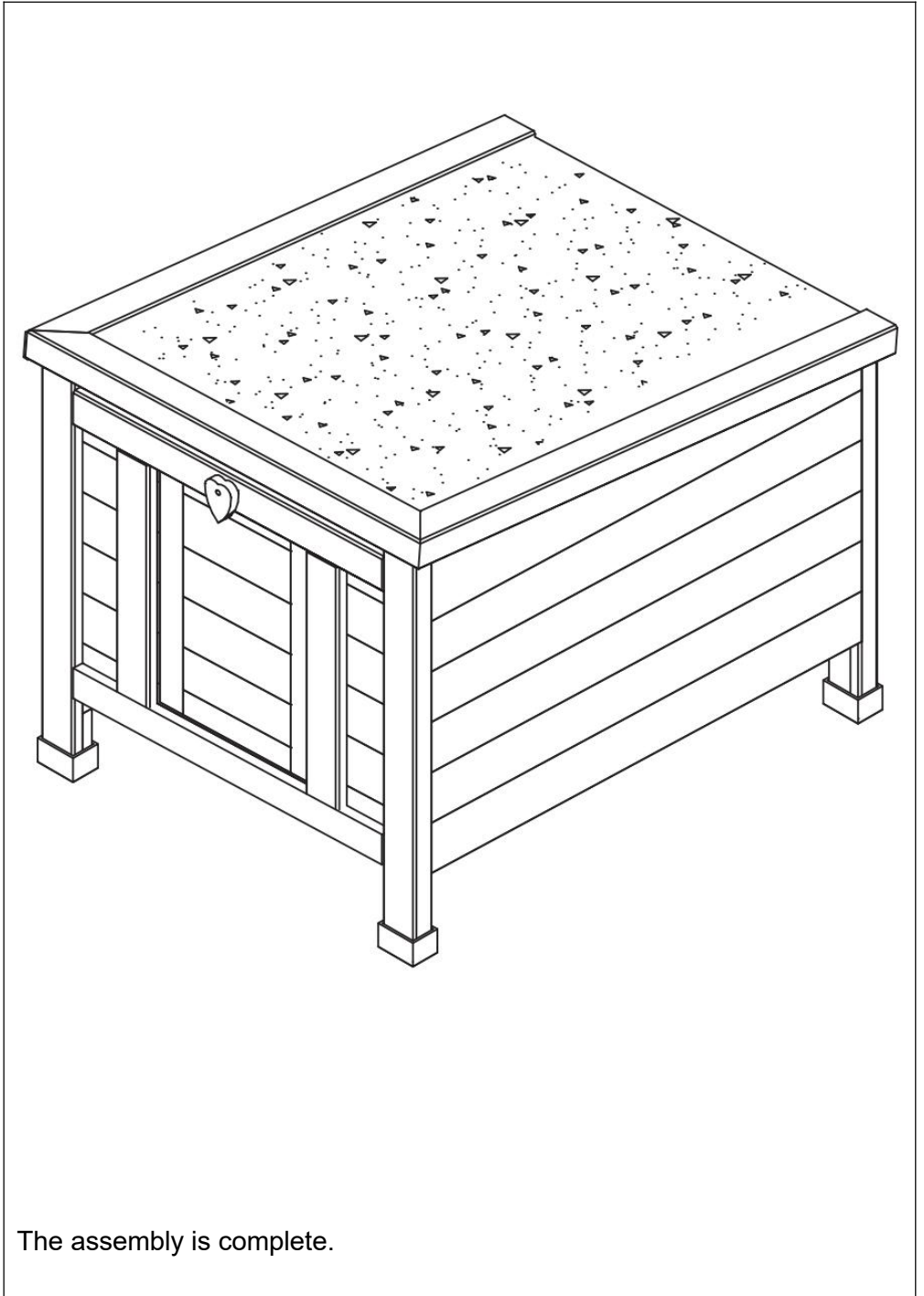

The assembly is complete.

**Manufacturer:**Shanghaimuxinmuyeyouxiangongsi

**Address:** Shuangchenglu 803nong11hao1602A-1609shi, baoshanqu, shanghai 200000 CN.

**Imported to AUS:** SIHAO PTY LTD. 1 ROKEVA STREETEASTWOOD NSW 2122 Australia

**Imported to USA:** Sanven Technology Ltd. Suite 250, 9166 Anaheim Place, Rancho Cucamonga, CA 91730

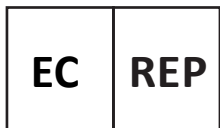

E-CrossStu GmbH

Mainzer Landstr.69, 60329 Frankfurt am Main.



YH CONSULTING LIMITED.

C/O YH Consulting Limited Office 147, Centurion House,  
London Road, Staines-upon-Thames, Surrey, TW18 4AX



**ESTILO GABINETE DE MADERA**  
**REFUGIO PARA GATOS**  
**MANUAL DE USUARIO**

# CABINET STYLE WOODEN CAT SHELTER

DUSCH2401

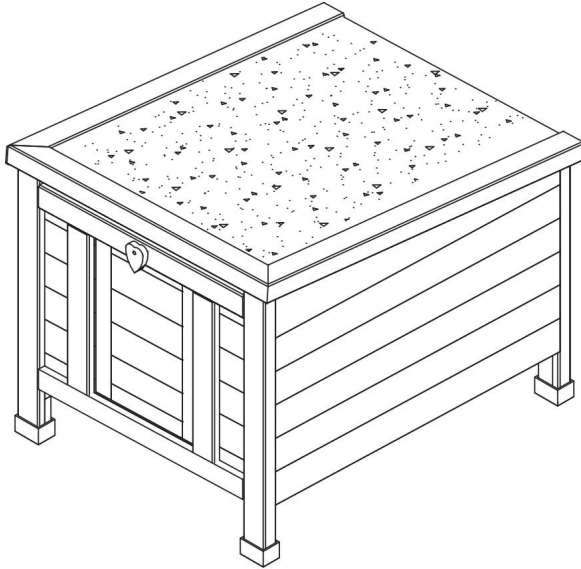

# Precauciones de seguridad

## ADVERTENCIA:

**Lea estas instrucciones** antes de usar este producto. De lo contrario, se pueden producir lesiones graves. Siempre se deben seguir las precauciones básicas , incluidas las siguientes:

7. El refugio para gatos de madera estilo gabinete No se puede utilizar ni almacenar en zonas peligrosas. No está permitido utilizar el aparato en lugares peligrosos.
8. El refugio para gatos de madera estilo gabinete Se debe verificar para garantizar que esté en buenas condiciones de funcionamiento y que funcione de manera segura antes de su uso. De lo contrario , no se debe utilizar el aparato.
9. Mantenga cerrado el techo del Kabinestell Wooden Carter Shelter, de lo contrario provocará la entrada de agua.
10. Limpie el estiércol y la basura de la casa con regularidad.
11. El operador debe utilizar el refugio para gatos de madera estilo gabinete. adecuadamente. Debe tener en cuenta las condiciones locales y prestar atención a terceros , en particular a los niños , cuando trabaje con el refugio para gatos de madera Cabinet Style .
12. Este refugio para gatos de madera estilo gabinete no está destinado a ser utilizado por personas (incluidos niños) con capacidades físicas , sensoriales o

mentales reducidas o que carezcan de experiencia y/o conocimientos , a menos que estén supervisados por una persona responsable de su seguridad o sean instruidos por estas personas sobre el uso de el dispositivo. Los niños deben ser supervisados para asegurarse de que no jueguen con el Refugio para gatos de madera estilo gabinete .

## **GUARDA ESTAS INSTRUCCIONES**

### **Lista de productos**

---

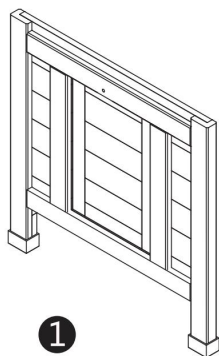

1

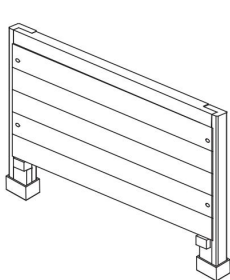

2

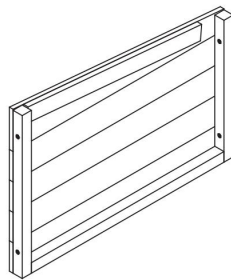

3

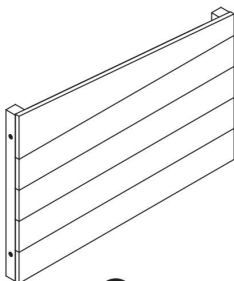

4

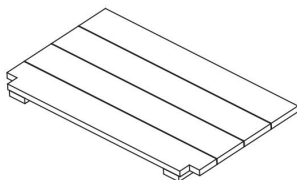

5 X2

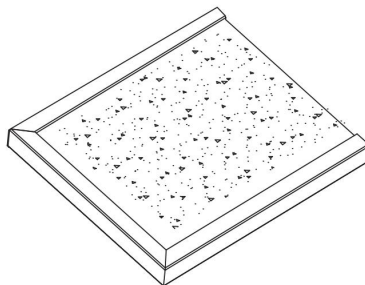

6

(A)  X8  
M6x50

(B)  X8+(1Spare part)  
3.0x16

(C)  X1

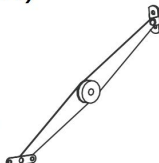
(D)  X1

## Producto A montaje

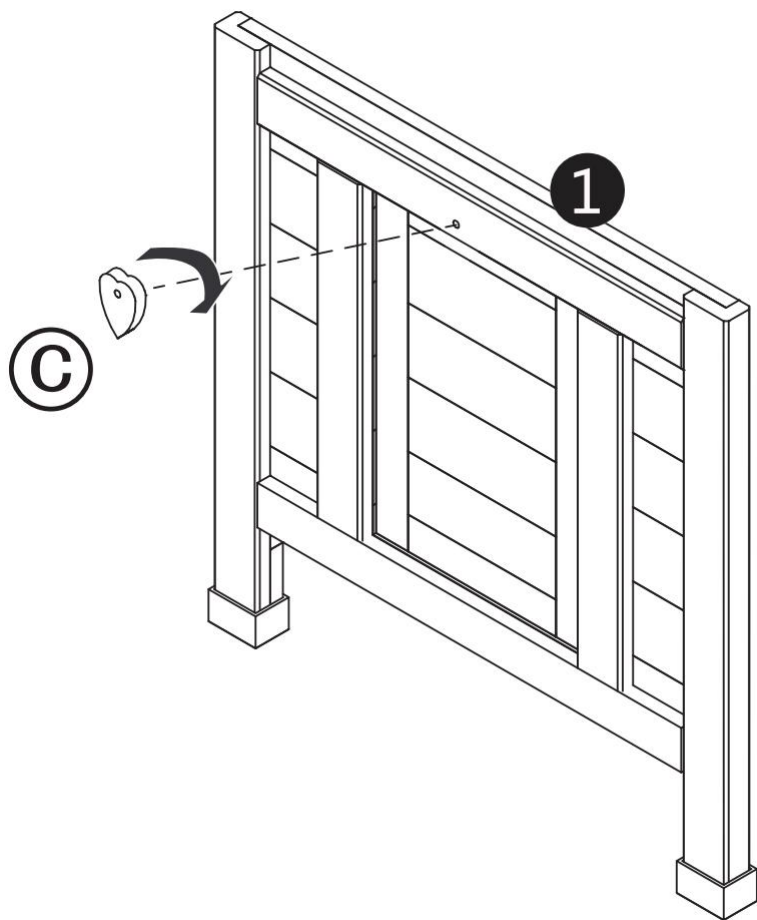

Ensamble la parte C encima de 1.

La parte C controla la apertura y el cierre de la puerta.

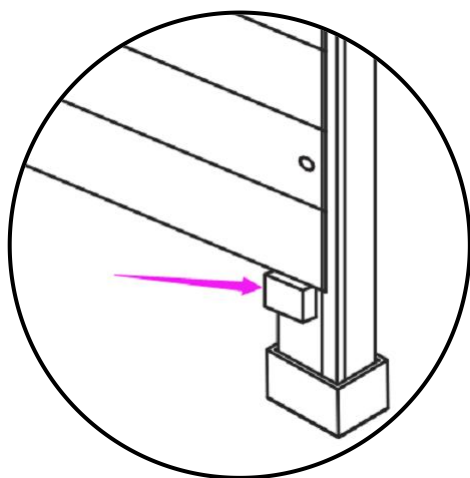
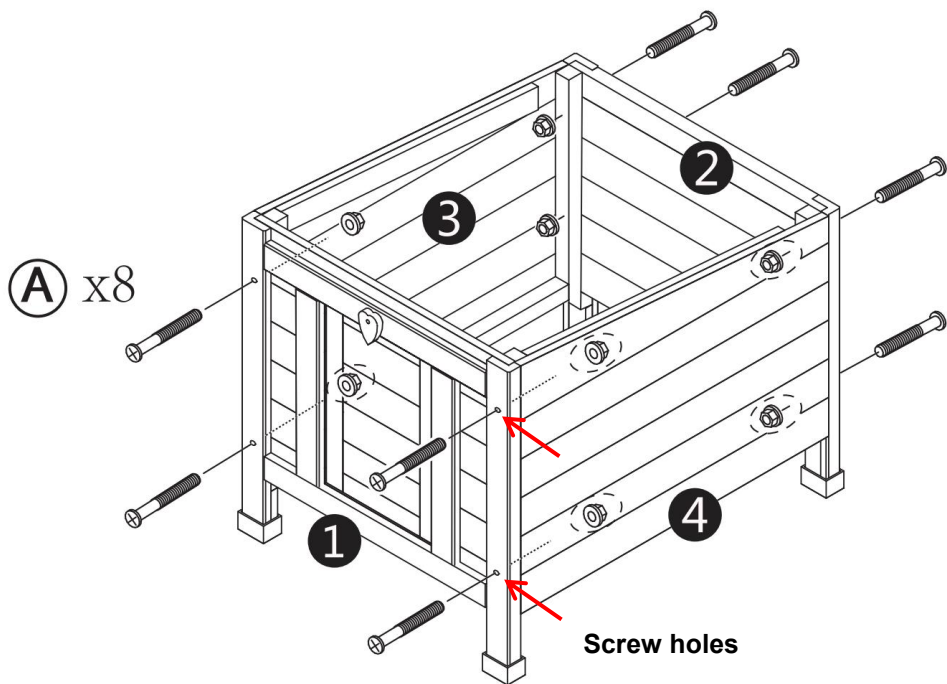

1 2 all have positioning pieces  
can be used and 3 4 for  
positioning assembly.

Ensamble y fije (1, 2, 3 y 4) con los tornillos A.

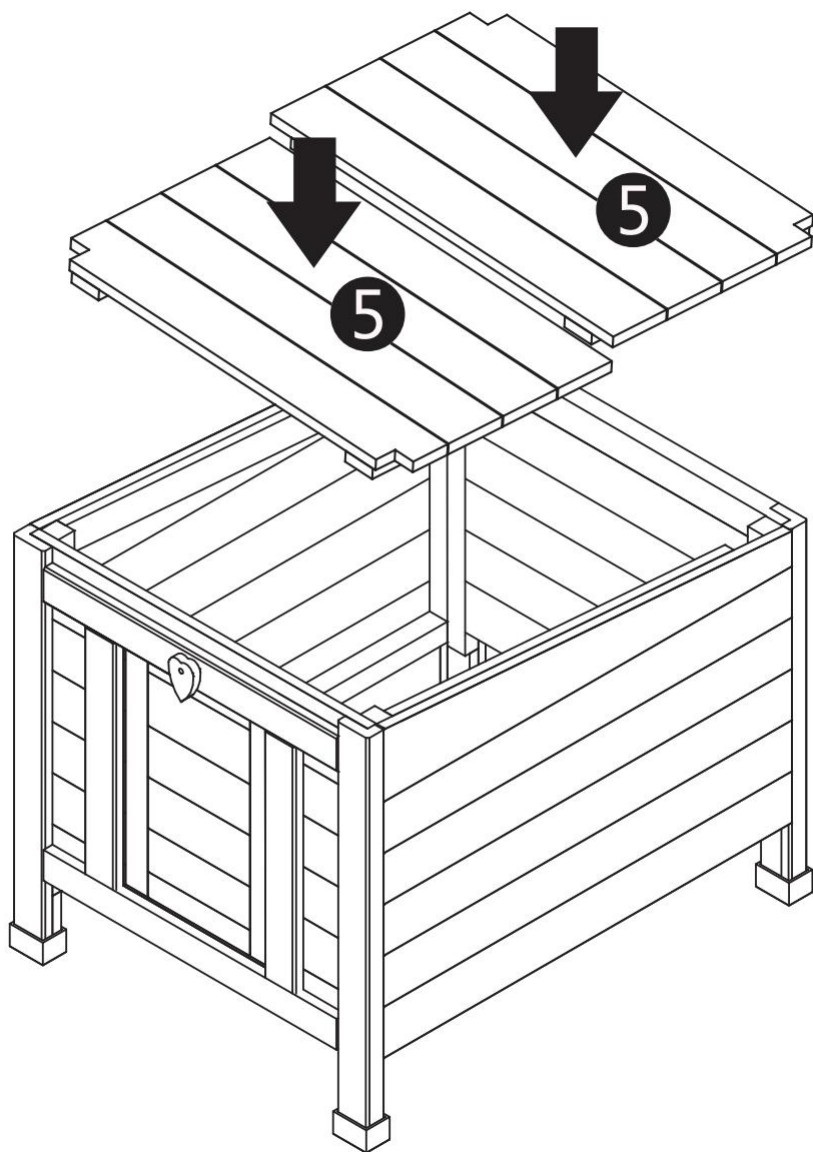

Pon 5 en la dirección de las flechas .

**Screw position marking**

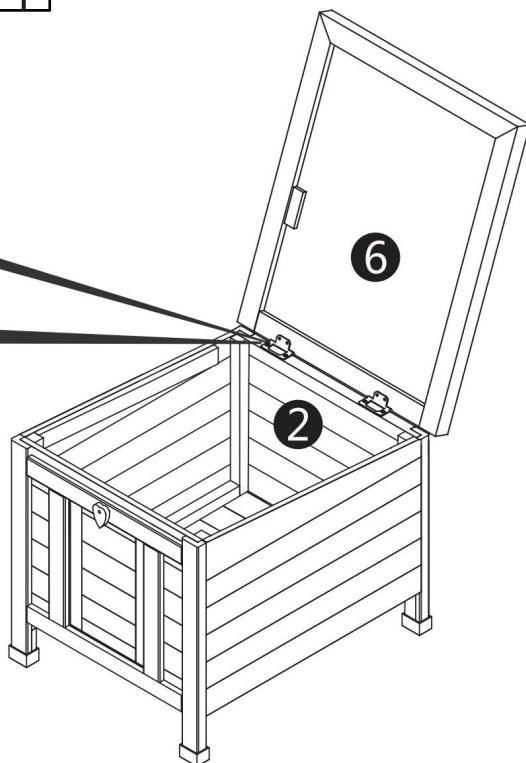
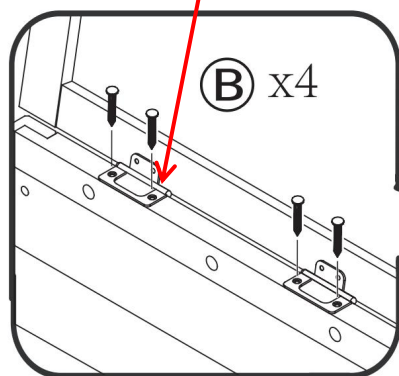
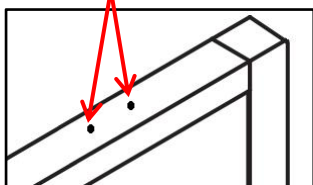

Montar (8) en la pieza frontal con el perno C.

**Nota: Para la instalación de tornillos, alinee los puntos de identificación de posición de los tornillos en los paneles laterales.**

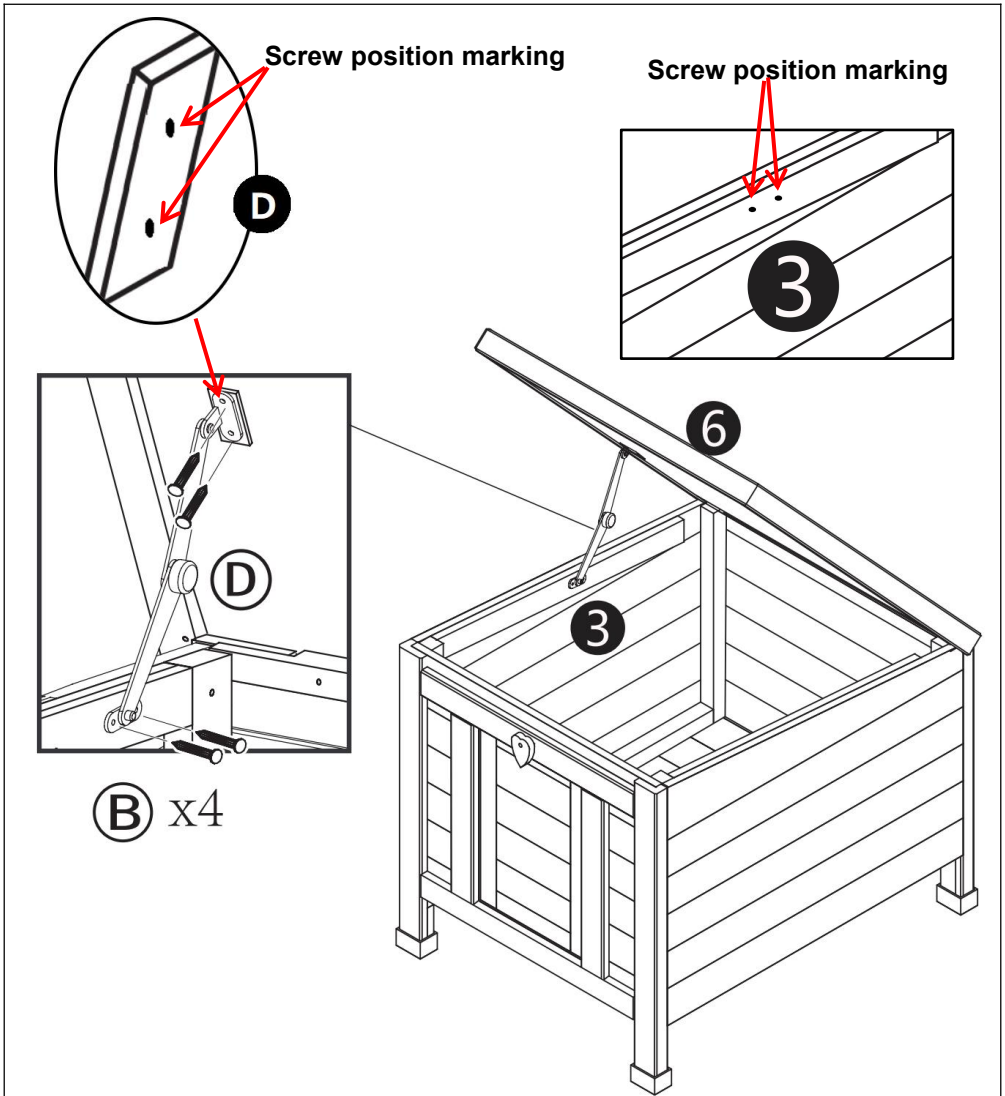

Ensamble los dos extremos de (D) en el techo y la lámina lateral izquierda con tornillos B .

**Nota:** Para la instalación de tornillos, alinee los puntos de identificación de posición de los tornillos en los paneles laterales.

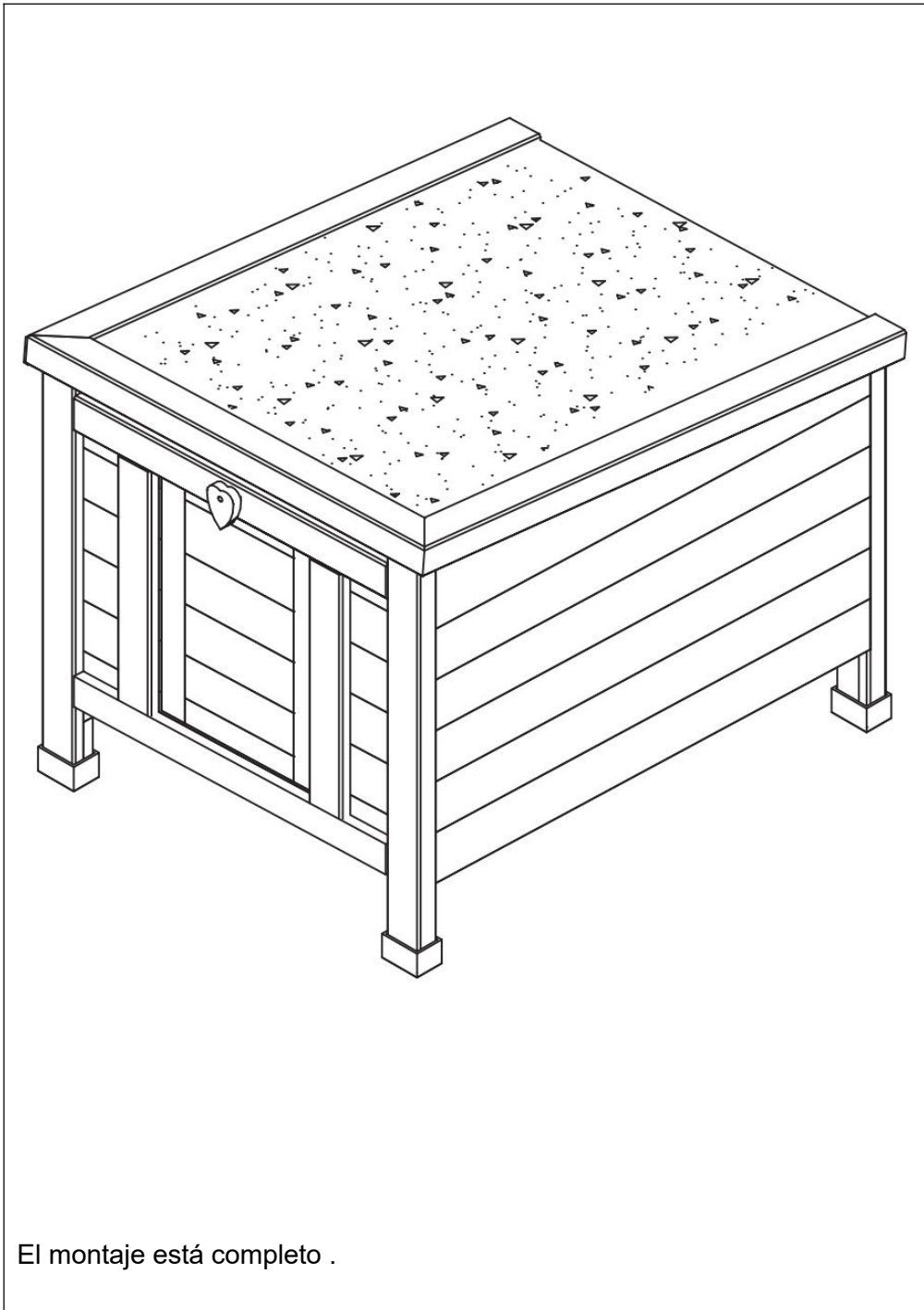

El montaje está completo .

**Fabricante** : Shanghaimuxinmuyeyouxiangongsi

**Dirección:** Shuangchenglu 803nong11hao1602A-1609shi, baoshanqu, shanghai 200000 CN.

**Importado a AUS:** SIHAO PTY LTD. 1 ROKEVA STREET ASTWOOD NSW 2122 Australia

**Importado a EE. UU.:** Sanven Technology Ltd. Suite 250, 9166 Anaheim Lugar, Rancho Cucamonga, CA 91730

<b>EC</b>	<b>REP</b>
-----------	------------

E-CrossStu GmbH

Mainzer Landstr.69, 60329 Frankfurt am Main.

<b>UK</b>	<b>REP</b>
-----------	------------

YH CONSULTING LIMITED.

C/O YH Consulting Limited Office 147, Centurion House,  
London Road, Staines-upon-Thames, Surrey, TW18 4AX



**MOBILE IN STILE LEGNO**  
**RIFUGIO PER GATTI**  
**MANUALE D'USO**

# CABINET STYLE WOODEN CAT SHELTER

DUSCH2401

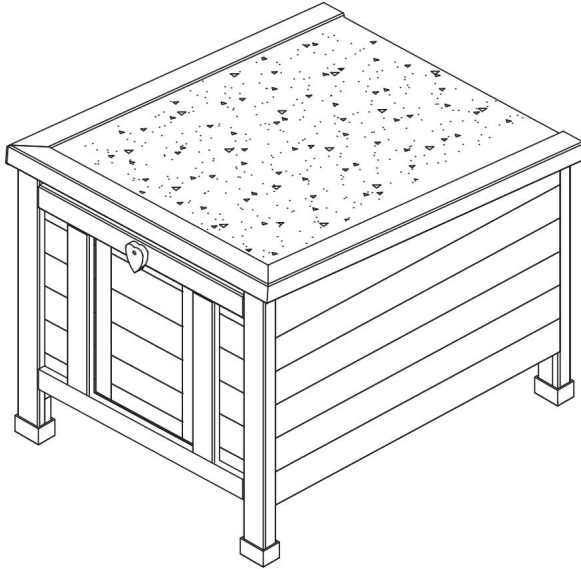

## Misure di sicurezza

### AVVERTIMENTO:

**Leggere queste istruzioni** prima di utilizzare questo prodotto. In caso contrario, si potrebbero verificare lesioni gravi. È necessario seguire sempre le precauzioni di base , incluse le seguenti:

13. Il rifugio per gatti in legno stile armadietto non può essere utilizzato o conservato in aree pericolose. Non è consentito utilizzare l'apparecchio in luoghi pericolosi.

14. Il rifugio per gatti in legno stile armadietto deve essere controllato per garantire che sia in buone condizioni di funzionamento e funzioni in sicurezza prima dell'uso. In caso contrario l' apparecchio non deve essere utilizzato.

15. Si prega di tenere chiuso il tetto del riparo in legno Kabinestell Carter, altrimenti potrebbe verificarsi l'ingresso di acqua.

16. Si prega di pulire regolarmente il letame e la spazzatura in casa.

17. L'operatore deve utilizzare il rifugio per gatti in legno stile armadio correttamente. Quando si lavora con il rifugio per gatti in legno Cabinet Style , è necessario considerare le condizioni locali e prestare attenzione a terzi , in particolare ai bambini .

18. Questo rifugio per gatti in legno in stile armadietto non è destinato all'uso da parte di persone (compresi i bambini) con ridotte capacità fisiche , sensoriali o

mentali o prive di esperienza e/o conoscenza , a meno che non siano supervisionate da una persona responsabile della loro sicurezza o siano istruite da queste persone sull'uso di il dispositivo. I bambini devono essere sorvegliati per assicurarsi che non giochino con il Rifugio per gatti in legno stile armadietto .

## **CONSERVA QUESTE ISTRUZIONI**

### **Elenco prodotti**

---

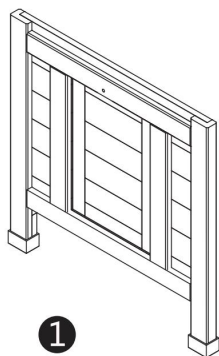

1

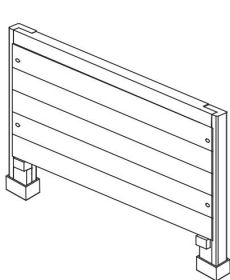

2

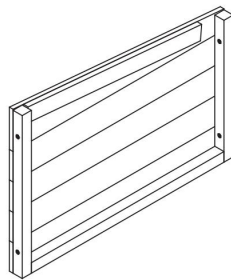

3

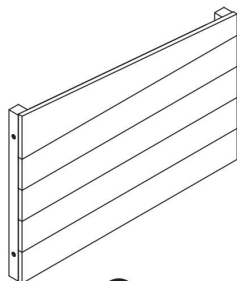

4

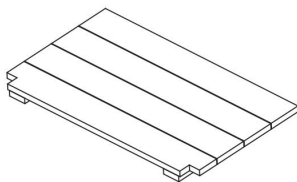

5 X2

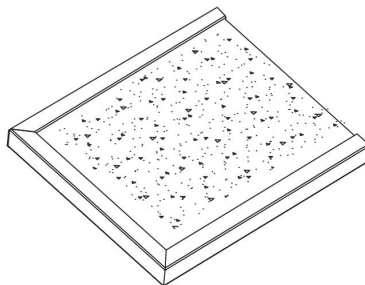

6

(A)  X8  
M6x50

(B)  X8+(1Spare part)  
3.0x16

(C)  X1

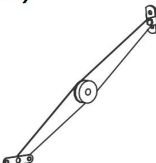
(D)  X1

**Prodotto A assemblaggio**

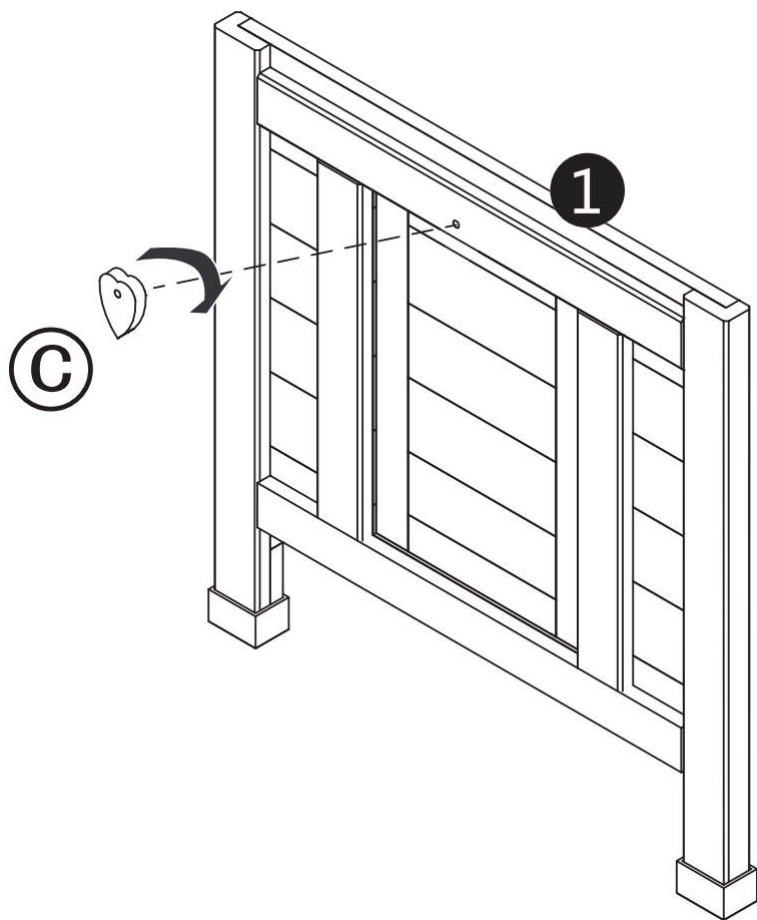

Assemblare la parte C sopra 1.

La parte C controlla l'apertura e la chiusura della porta.

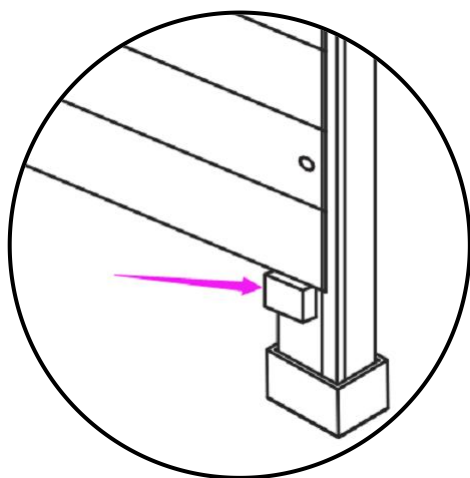
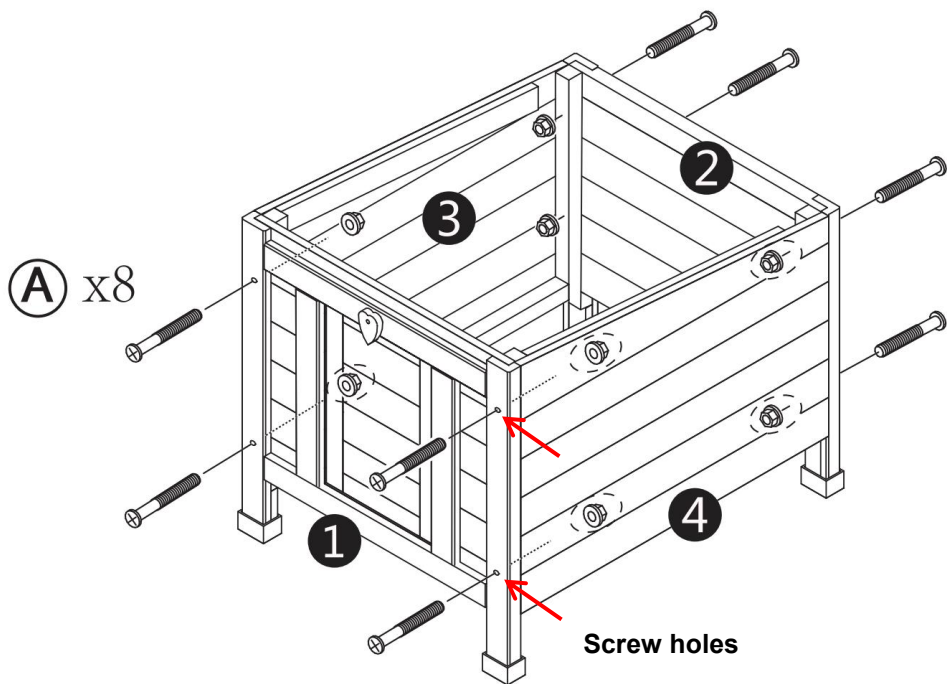

1 2 all have positioning pieces  
can be used and 3 4 for  
positioning assembly.

Montare e fissare (1, 2, 3 e 4) con le viti A .

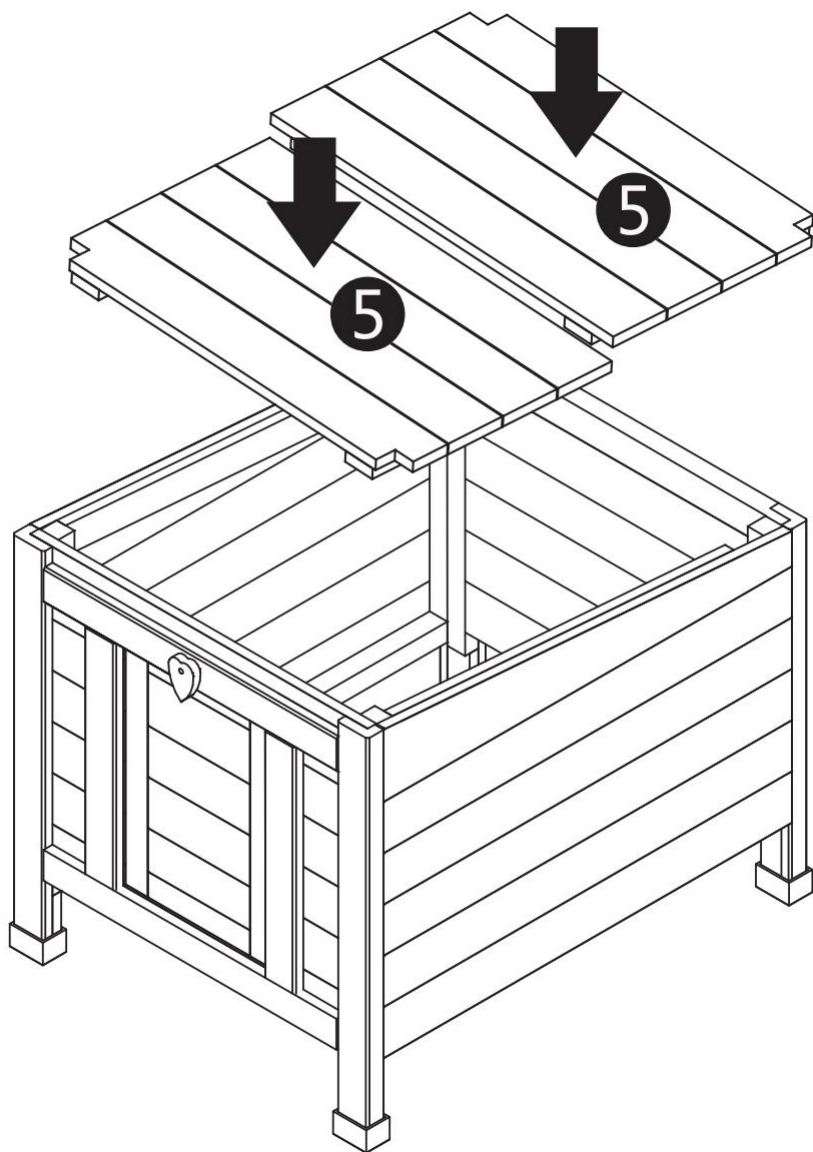

Metti 5 nella direzione delle frecce .

**Screw position marking**

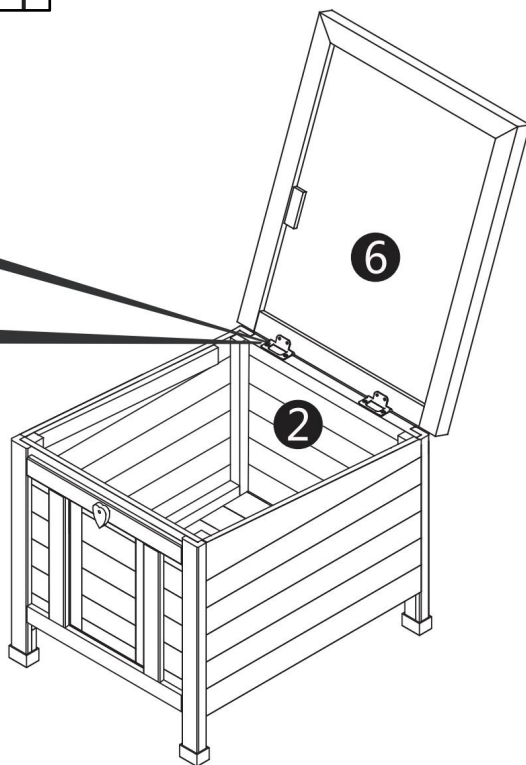
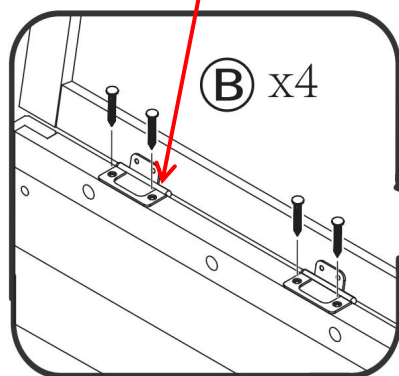
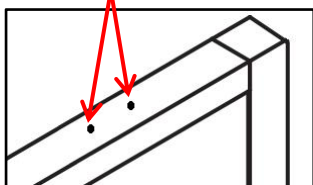

Montare (8) sulla parte anteriore con il bullone C .

**Nota: per l'installazione con viti, allineare i punti di identificazione del posizionamento delle viti sui pannelli laterali.**

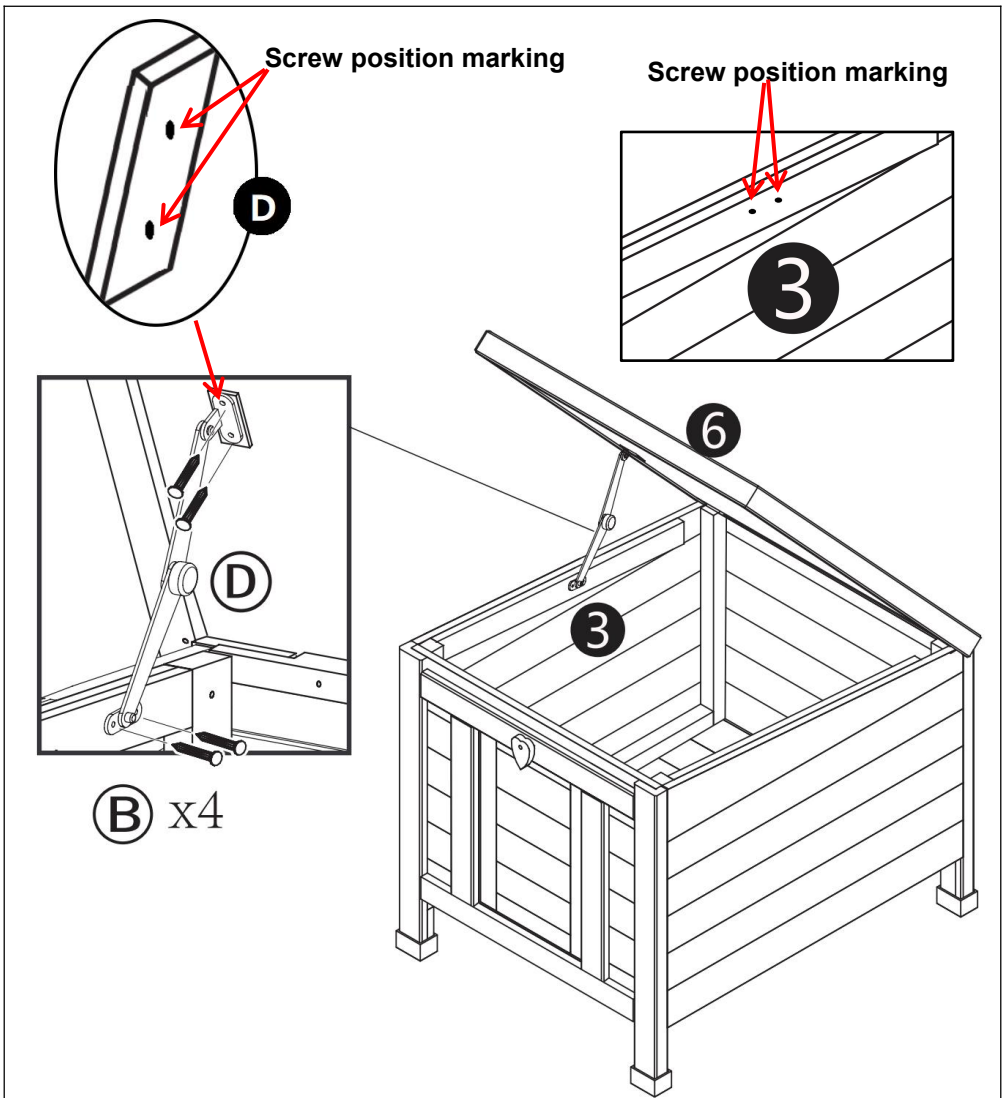

Assemblare le due estremità di (D) sul tetto e sulla lamiera laterale sinistra con le viti B .

**Nota: per l'installazione con viti, allineare i punti di identificazione del posizionamento delle viti sui pannelli laterali.**

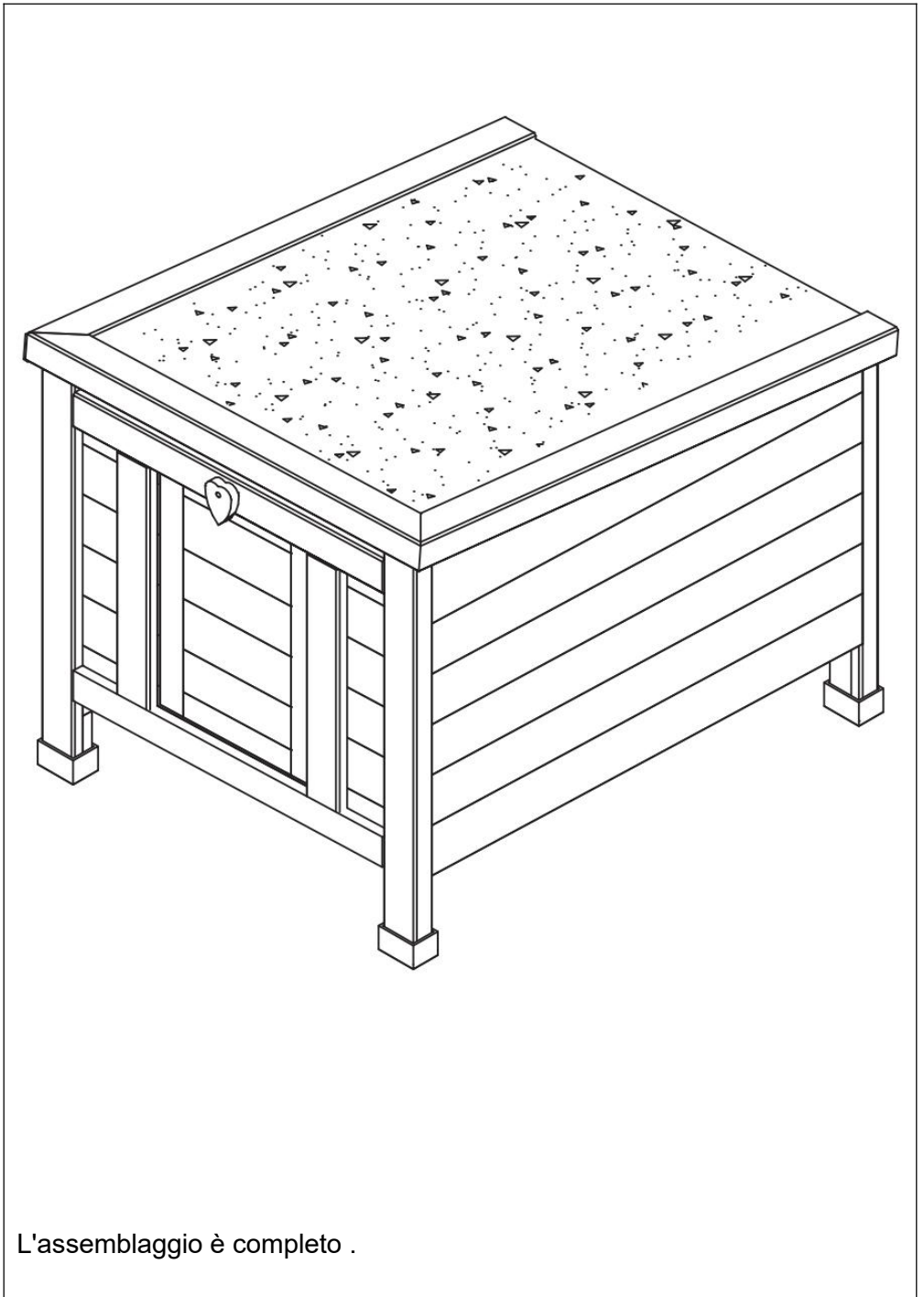

L'assemblaggio è completo .

**Produttore** : Shanghaimuxinmuyeyouxiangongsi

**Indirizzo**: Shuangchenglu 803nong11hao1602A-1609shi, baoshanqu, shanghai 200000 CN.

**Importato in AUS**: SIHAO PTY LTD. 1 ROKEVA STREETEASTWOOD NSW 2122 Australia

**Importato negli Stati Uniti**: Sanven Technology Ltd. Suite 250, 9166 Anaheim

Luogo, Rancho Cucamonga, CA 91730

<b>EC</b>	<b>REP</b>
-----------	------------

E-CrossStu GmbH

Mainzer Landstr.69, 60329 Frankfurt am Main.

<b>UK</b>	<b>REP</b>
-----------	------------

YH CONSULTING LIMITED.

C/O YH Consulting Limited Office 147, Centurion House,  
London Road, Staines-upon-Thames, Surrey, TW18 4AX



**SZAFKA W STYLU DREWNIANYM**  
**SCHRONISKO DLA KOTÓW**  
**INSTRUKCJA OBSŁUGI**

# CABINET STYLE WOODEN CAT SHELTER

DUSCH2401

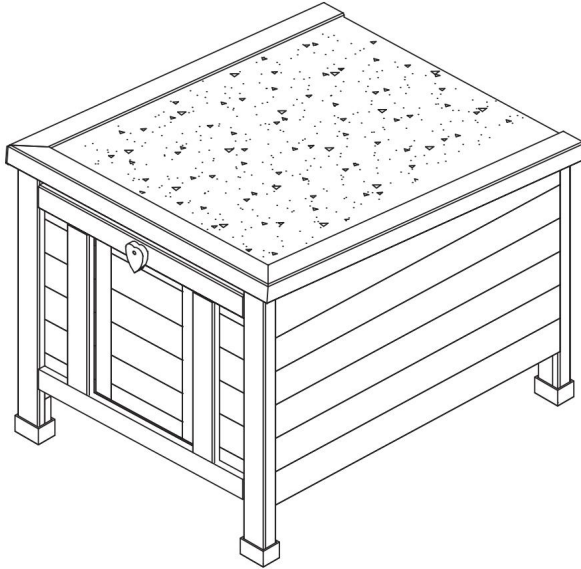

# Środki ostrożności

## OSTRZEŻENIE:

**Przeczytaj tę instrukcję** przed użyciem tego produktu. Niezastosowanie się do tego może spowodować poważne obrażenia. należy zawsze przestrzegać podstawowych środków ostrożności , w tym:

19. Drewniane schronisko dla kota w stylu szafki nie wolno używać ani przechowywać w obszarach niebezpiecznych. Nie wolno używać urządzenia w miejscach niebezpiecznych.
20. Drewniane schronisko dla kota w stylu szafki przed użyciem należy sprawdzić, czy jest w dobrym stanie i czy działa bezpiecznie. W przeciwnym razie nie wolno używać urządzenia.
21. Dach wiaty Kabinestell Wooden Carter Shelter powinien być zamknięty, w przeciwnym razie spowoduje to wnikanie wody.
22. Prosimy o regularne sprzątanie domu z obornika i śmieci.
23. Operator musi korzystać z drewnianego schroniska dla kota w kształcie szafki odpowiednio. Podczas pracy z drewnianym schroniskiem dla kotów typu Cabinet Style musi on wziąć pod uwagę lokalne warunki i zwracać uwagę na osoby trzecie , w szczególności na dzieci .
24. To drewniane schronisko dla kota w stylu szafki nie jest przeznaczony do użytku przez osoby (w tym dzieci) o ograniczonych zdolnościach fizycznych ,

sensorycznych lub umysłowych lub nieposiadające doświadczenia i/lub wiedzy ,  
chyba że znajdują się pod nadzorem osoby odpowiedzialnej za ich  
bezpieczeństwo lub zostaną przez te osoby poinstruowane w zakresie obsługi  
urządzenie. Dzieci należy nadzorować , aby mieć pewność, że nie bawią się  
urządzeniem Drewniane schronisko dla kota w stylu szafki .

## **ZACHOWAJ TE INSTRUKCJE**

### **Lista produktów**

---

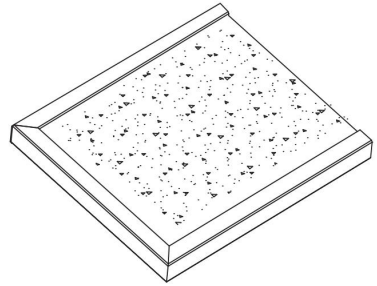
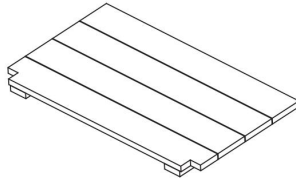
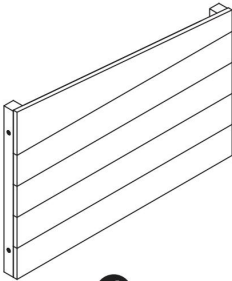
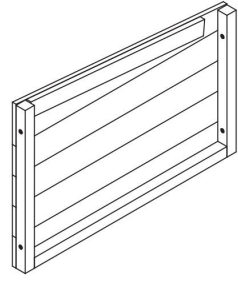
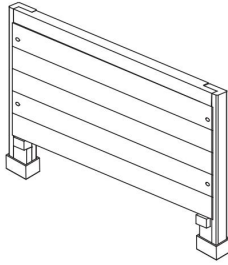
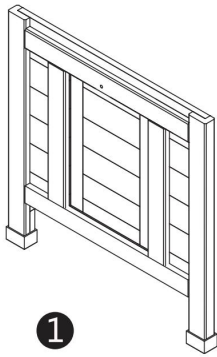

(A)  X8  
M6x50

(B)  X8+(1Spare part)  
3.0x16

(C)  X1

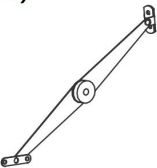
(D)  X1

## Produkt A

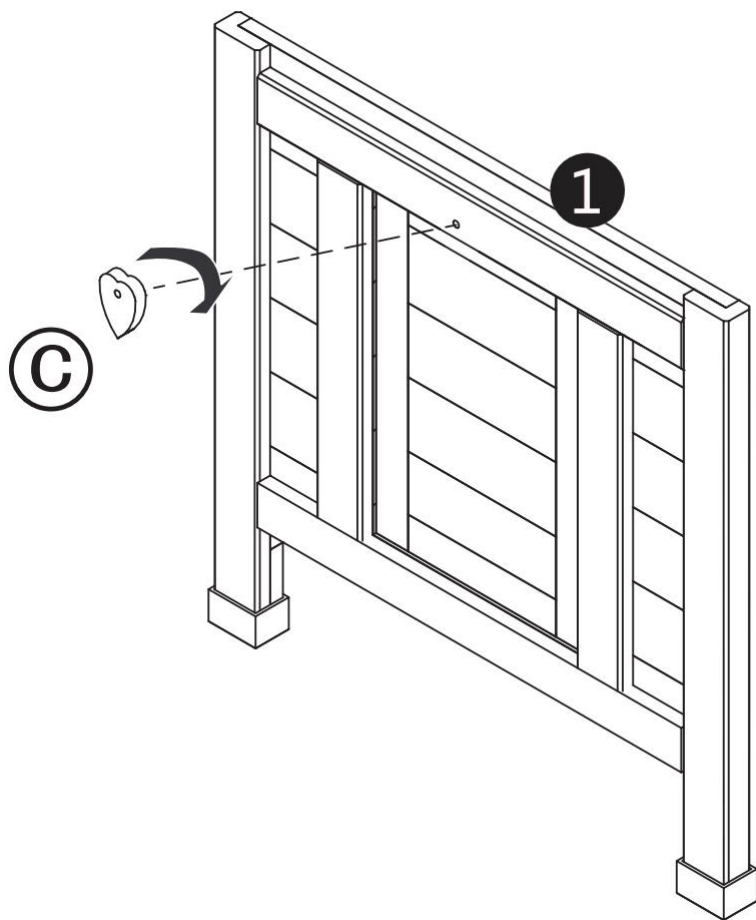

Zamontuj część C na górze 1.  
Część C steruje otwieraniem i zamykaniem drzwi.

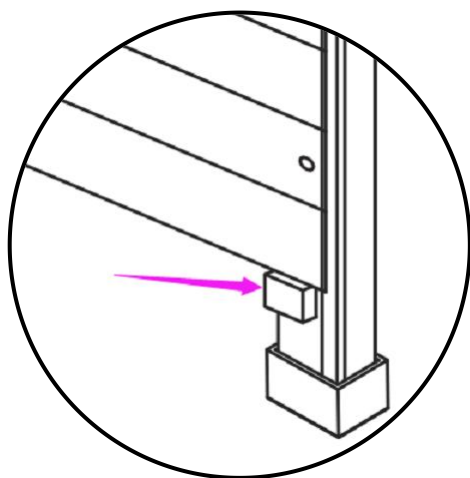
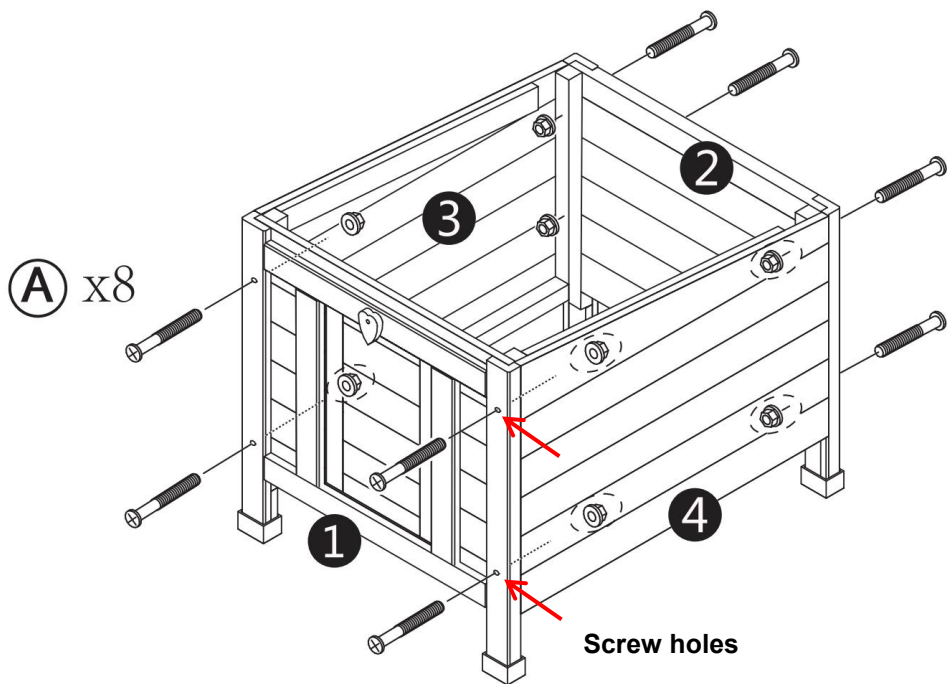

1 2 all have positioning pieces  
can be used and 3 4 for  
positioning assembly.

Zmontować i przymocować (1, 2, 3 i 4) śrubami A.

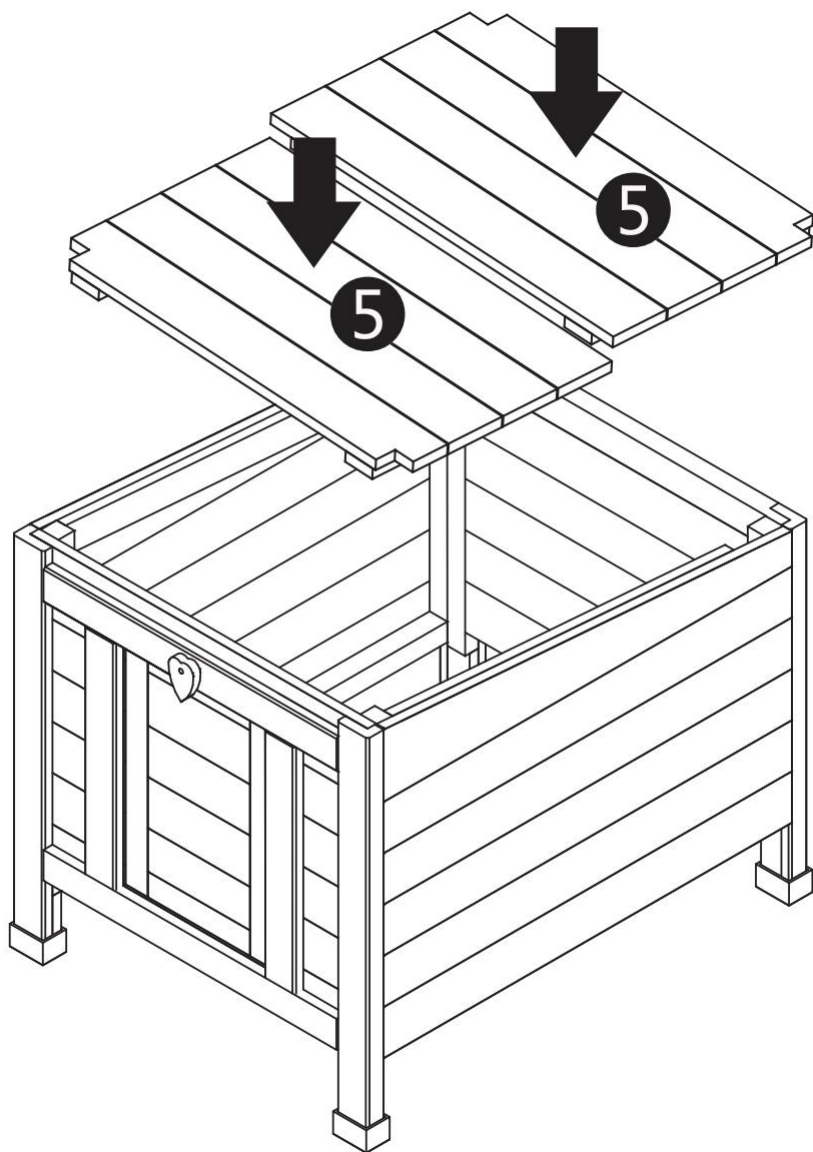

Wpisz 5 w kierunku strzałek .

### Screw position marking

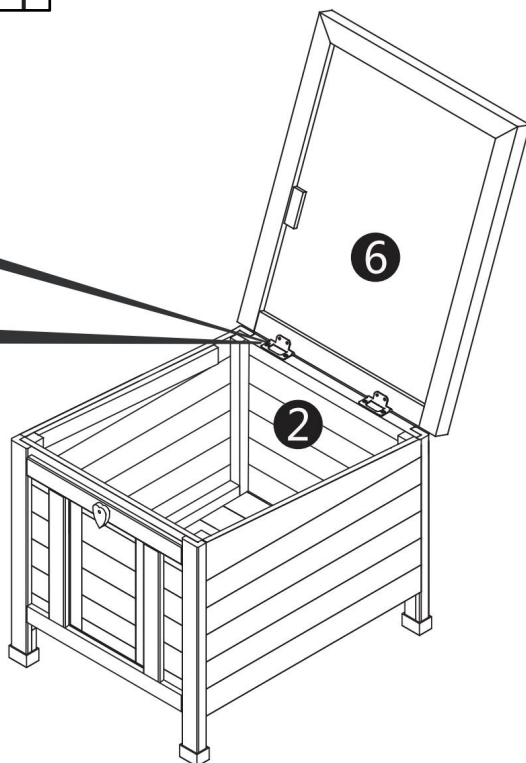
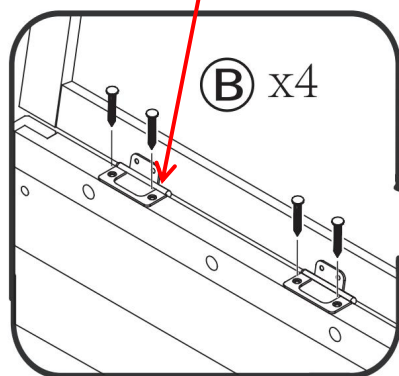
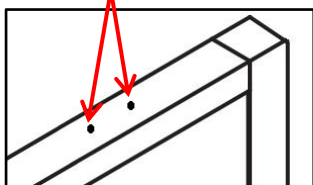

Zamontować (8) na części przedniej za pomocą śruby C .

**Uwaga: W przypadku montażu śrubowego wyrównaj punkty identyfikacyjne położenia śrub na panelach bocznych.**

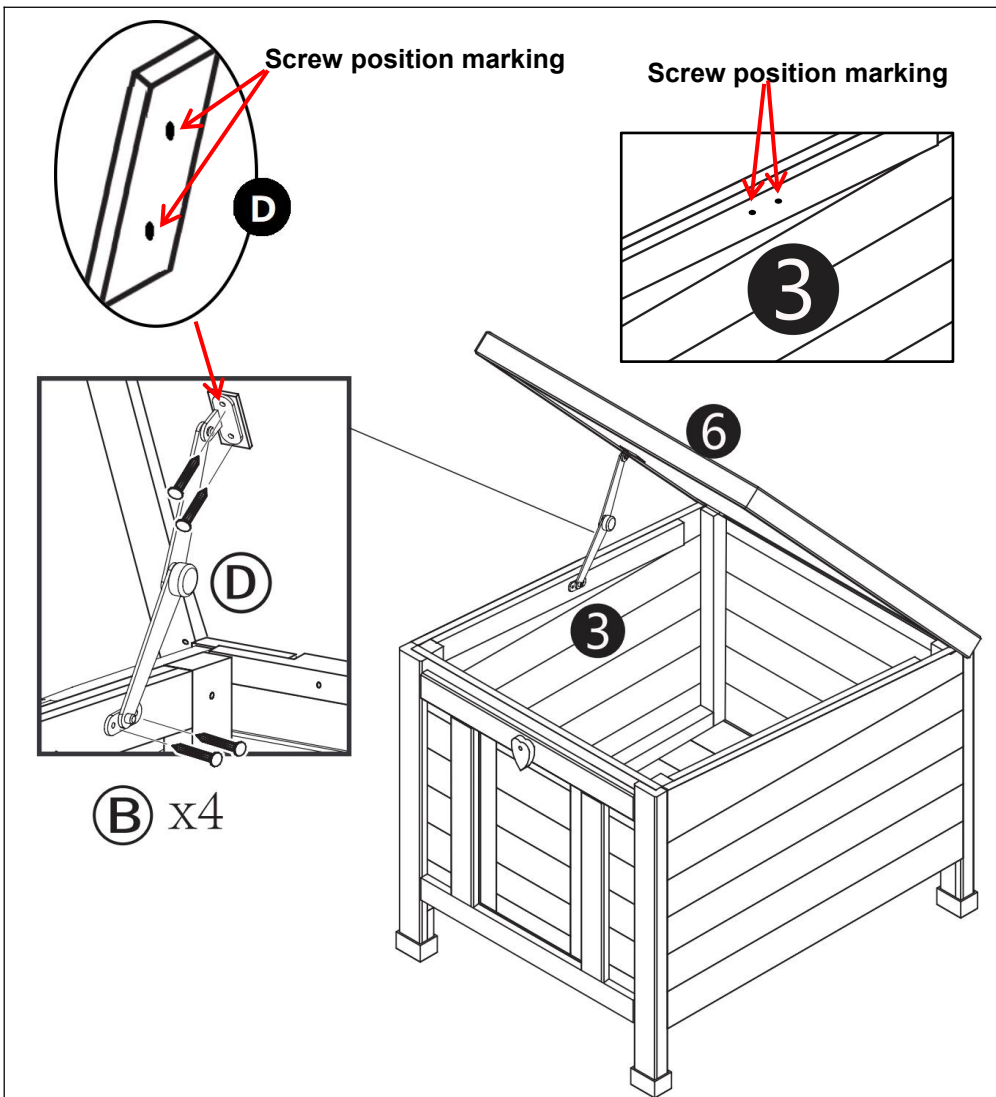

Zamontuj dwa końce (D) na dachu i lewym arkuszu bocznym za pomocą śrub B .

**Uwaga: W przypadku montażu śrubowego wyrównaj punkty identyfikacyjne położenia śrub na panelach bocznych.**

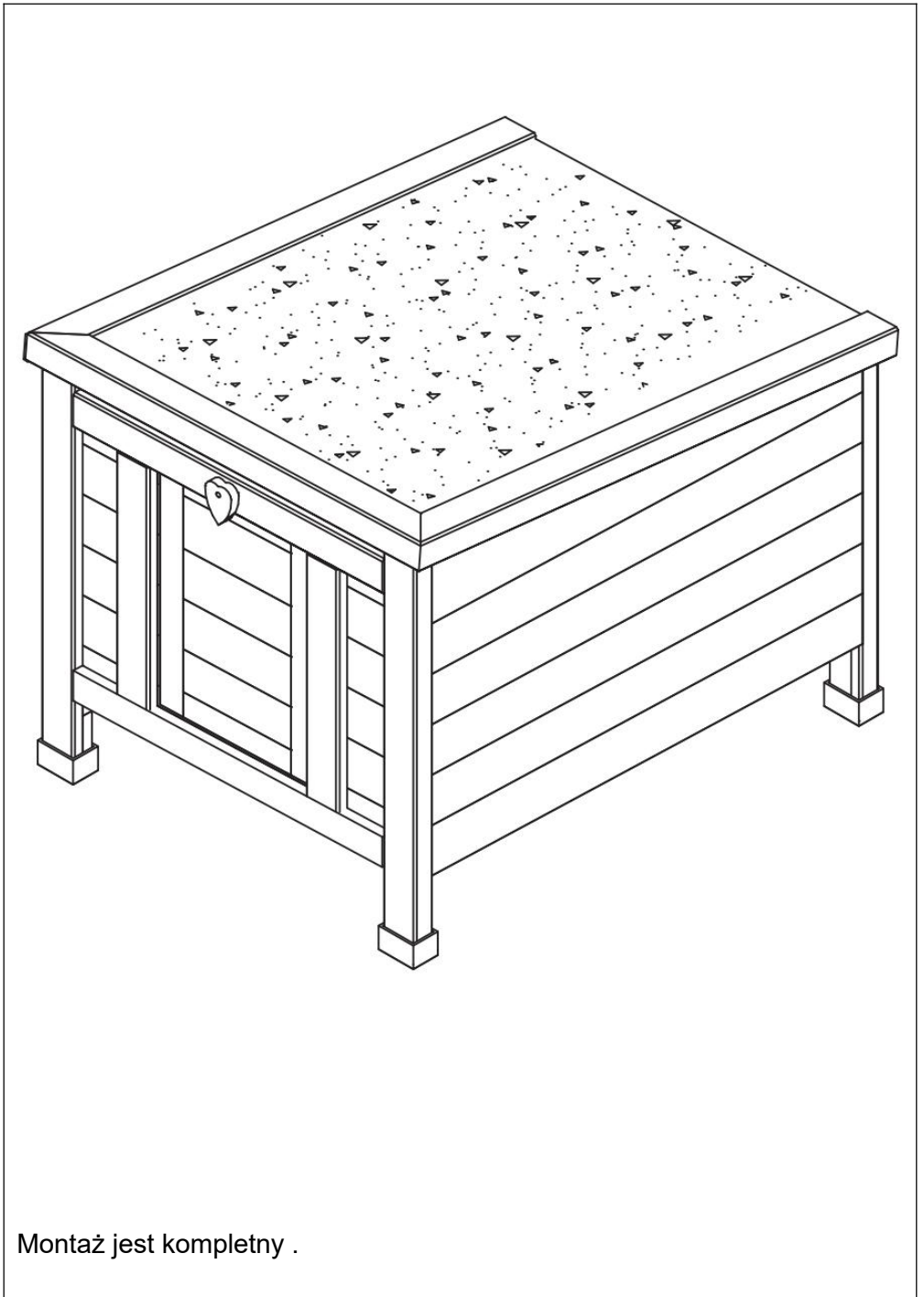

Montaż jest kompletny .

**Producent** : Shanghaimuxinmuyeyouxiangongsi

**Adres**: Shuangchenglu 803nong11hao1602A-1609shi, baoshanqu, szanghaj 200000 CN.

**Import do AUS**: SIHAO PTY LTD. 1 ROKEVA STREETEASTWOOD NSW 2122 Australia

**Import do USA**: Sanven Technology Ltd. Suite 250, 9166 Anaheim Place, Rancho Cucamonga, Kalifornia 91730

<b>EC</b>	<b>REP</b>
-----------	------------

E-CrossStu GmbH

Mainzer Landstr.69, 60329 Frankfurt am Main.

<b>UK</b>	<b>REP</b>
-----------	------------

YH CONSULTING LIMITED.

C/O YH Consulting Limited Office 147, Centurion House,  
London Road, Staines-upon-Thames, Surrey, TW18 4AX



**SCHRANKSTIL: HOLZ**  
**KATZENUNTERKUNFT**  
**BENUTZERHANDBUCH**

# CABINET STYLE WOODEN CAT SHELTER

DUSCH2401

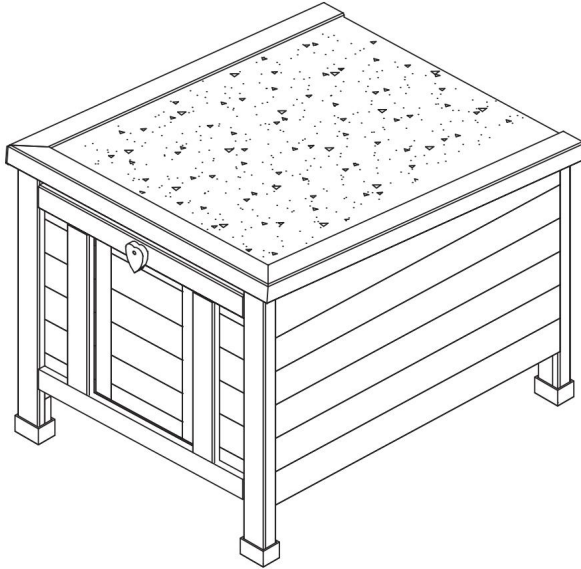

# Sicherheitsvorkehrungen

## WARNUNG:

**Lesen Sie diese Anweisungen**, bevor Sie dieses Produkt verwenden.

Andernfalls kann es zu schweren Verletzungen kommen. Die grundlegenden Vorsichtsmaßnahmen sollten immer befolgt werden , einschließlich der folgenden:

25. Der hölzerne Katzenunterstand im Schrankstil darf nicht in explosionsgefährdeten Bereichen verwendet oder gelagert werden. Der Einsatz des Gerätes in explosionsgefährdeten Bereichen ist nicht gestattet.

26. Der hölzerne Katzenunterstand im Schrankstil muss vor der Inbetriebnahme auf Funktionstüchtigkeit und Betriebssicherheit geprüft werden. Andernfalls darf das Gerät nicht verwendet werden.

27. Bitte halten Sie das Dach des Kabinestell Wooden Carter Shelter geschlossen, da sonst Wasser eindringen kann.

28. Bitte räumen Sie regelmäßig den Mist und Müll im Haus weg.

29. Der Betreiber muss den Cabinet Style Wooden Cat Shelter verwenden Er muss die örtlichen Gegebenheiten berücksichtigen und bei der Arbeit mit dem Katzenhaus im Schrankstil aus Holz auf Dritte , insbesondere Kinder , achten .

30. Dieser hölzerne Katzenunterstand im Schrankstil ist nicht für die Benutzung durch Personen (einschließlich Kinder) mit eingeschränkten physischen , sensorischen oder geistigen Fähigkeiten oder mangelnder Erfahrung und/oder

Kenntnissen bestimmt , es sei denn, sie werden von einer für ihre Sicherheit verantwortlichen Person beaufsichtigt oder von dieser Person in die Benutzung des Geräts eingewiesen. Kinder sollten beaufsichtigt werden , um sicherzustellen, dass sie nicht mit dem Gerät spielen. Katzenunterstand aus Holz im Schrankstil .

## **ANLEITUNG AUFBEWAHREN**

### **Produktliste**

---

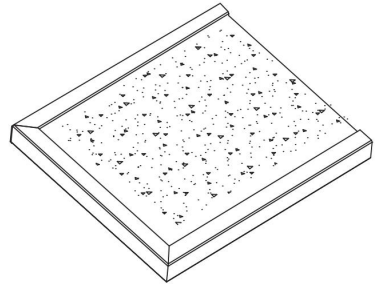
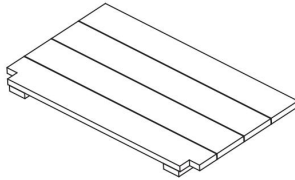
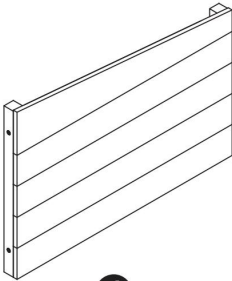
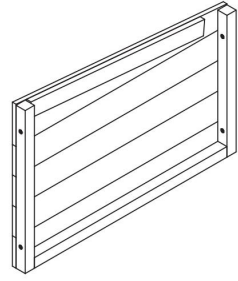
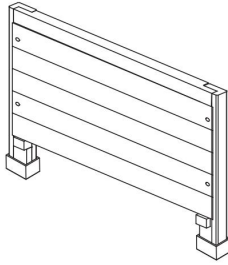
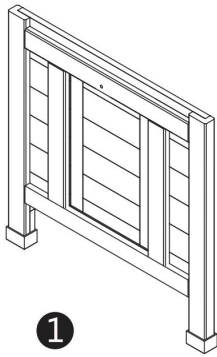

(A)  X8  
M6x50

(B)  X8+(1Spare part)  
3.0x16

(C)  x1

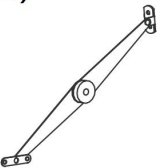
(D)  x1

## Produktzusammenstellung

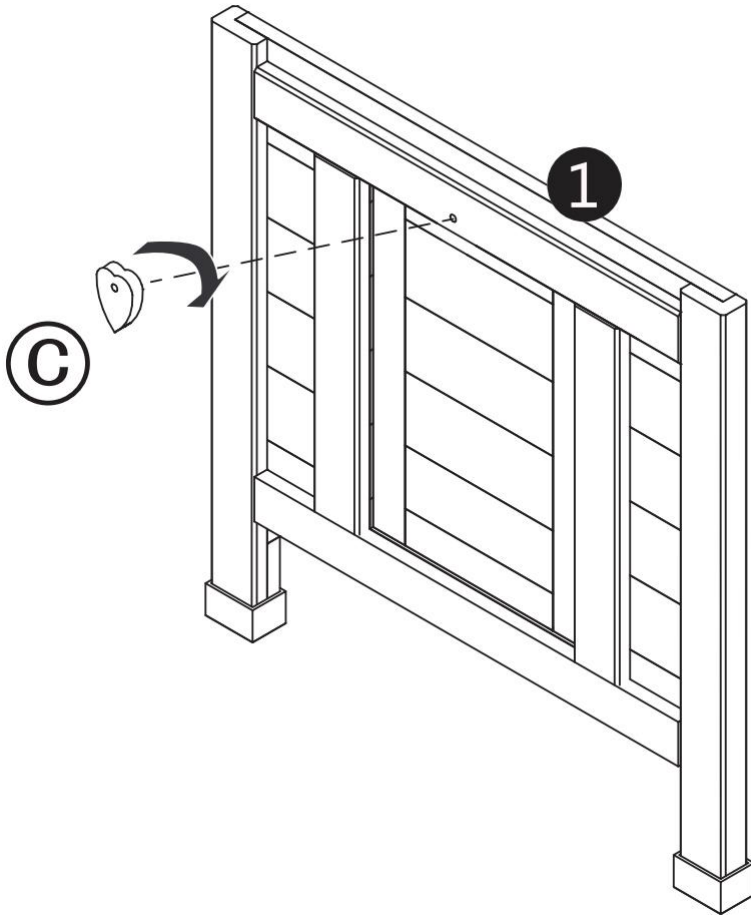

Montieren Sie Teil C oben auf Teil 1.  
Teil C steuert das Öffnen und Schließen der Tür.

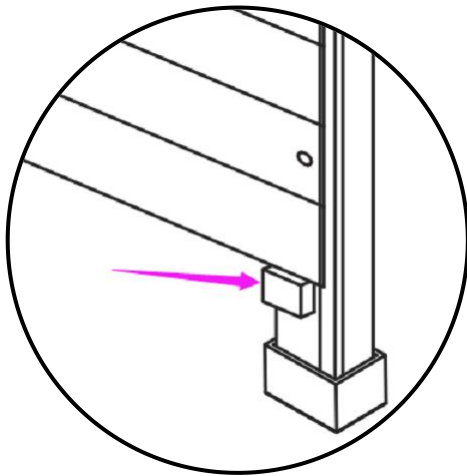
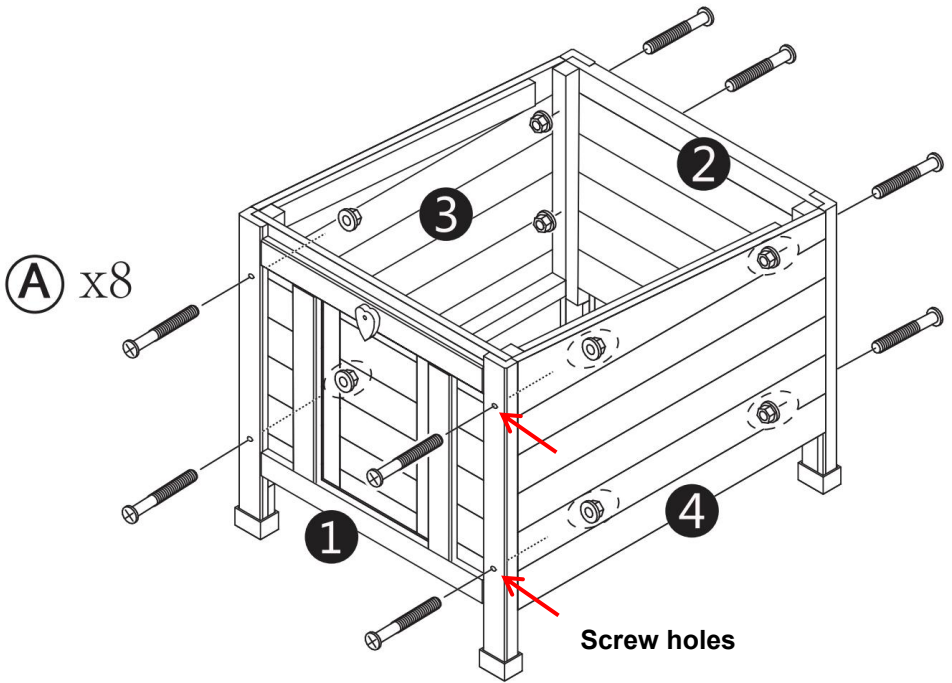

1 2 all have positioning pieces  
can be used and 3 4 for  
positioning assembly.

Zusammenbauen und (1, 2, 3 und 4) mit den Schrauben A befestigen .

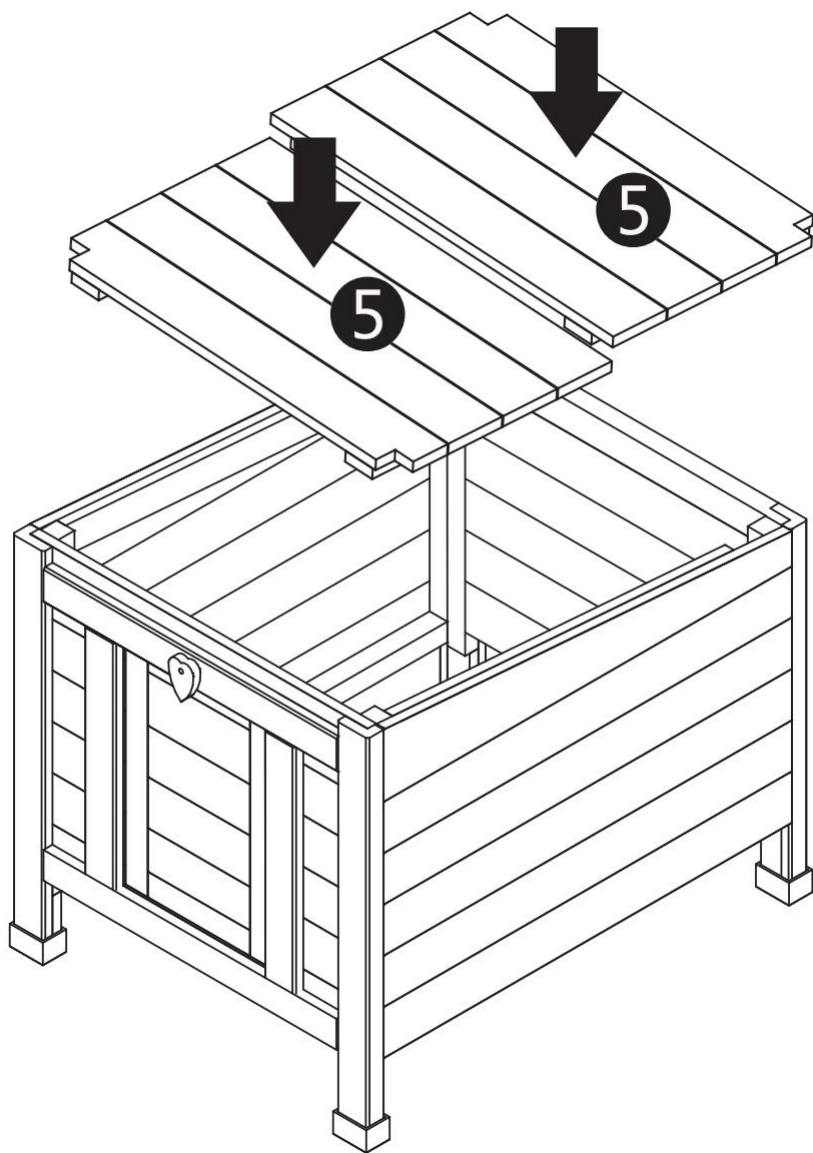

Setzen Sie 5 in Pfeilrichtung ein .

**Screw position marking**

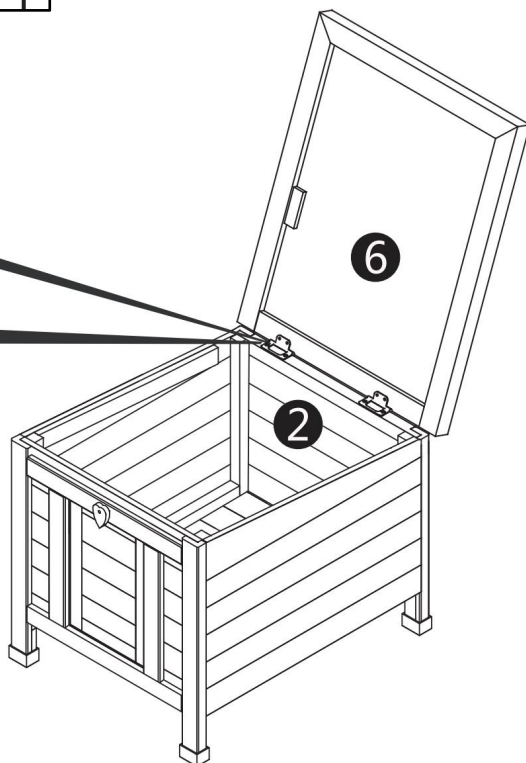
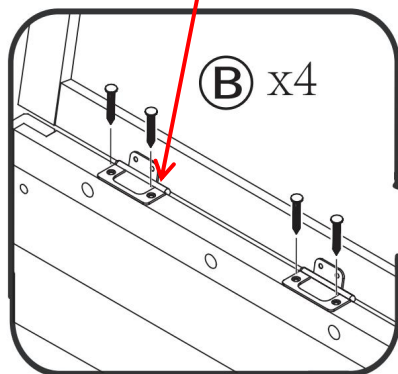
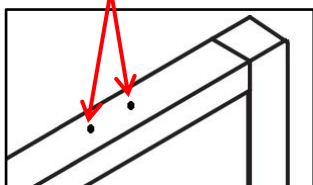

(8) mit Schraube C am Vorderteil montieren .

**Hinweis: Richten Sie zur Schraubmontage die Schraubenpositionierungs-Kennzeichnungspunkte an den**

## Seitenwänden aus.

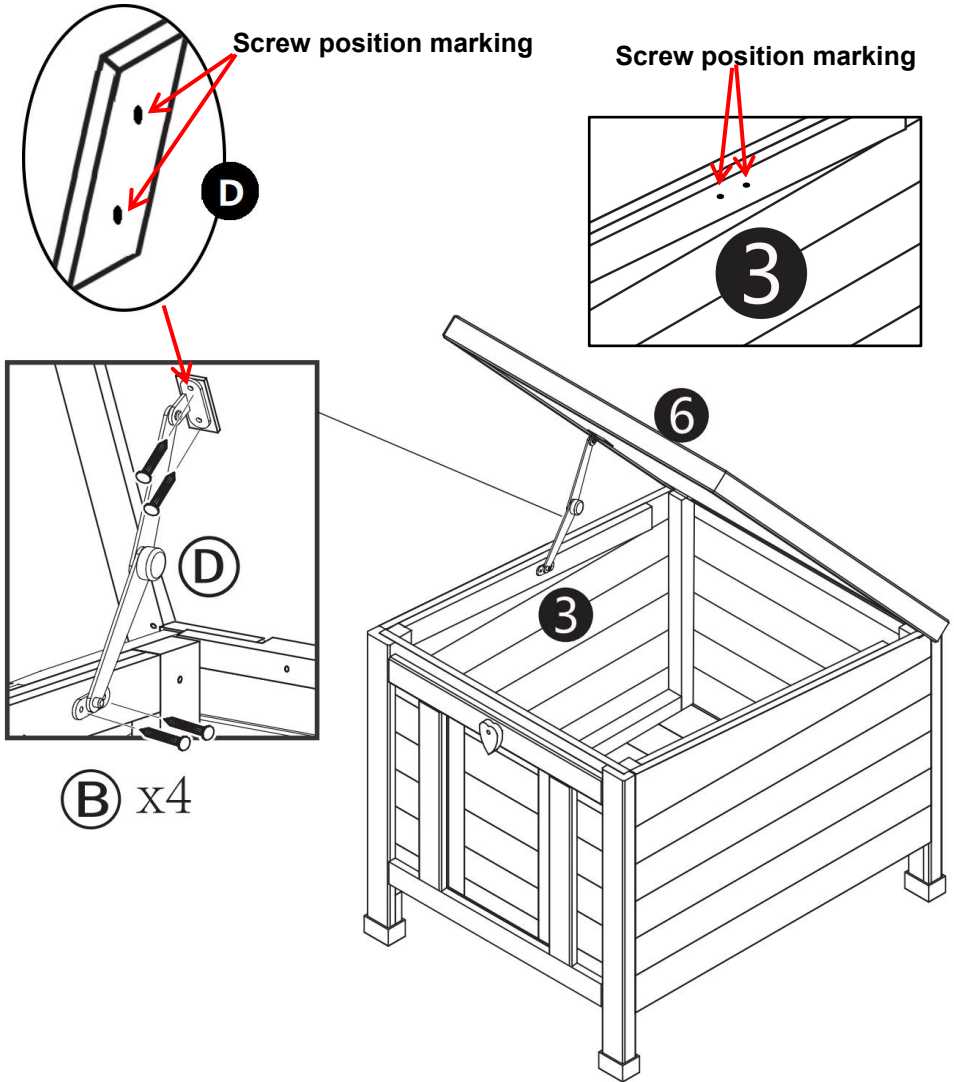

Montieren Sie die beiden Enden von (D) mit den Schrauben B am Dach und am linken Seitenblech .

**Hinweis: Richten Sie zur Schraubmontage die**

**Schraubenpositionierungs-Kennzeichnungspunkte an den  
Seitenwänden aus.**

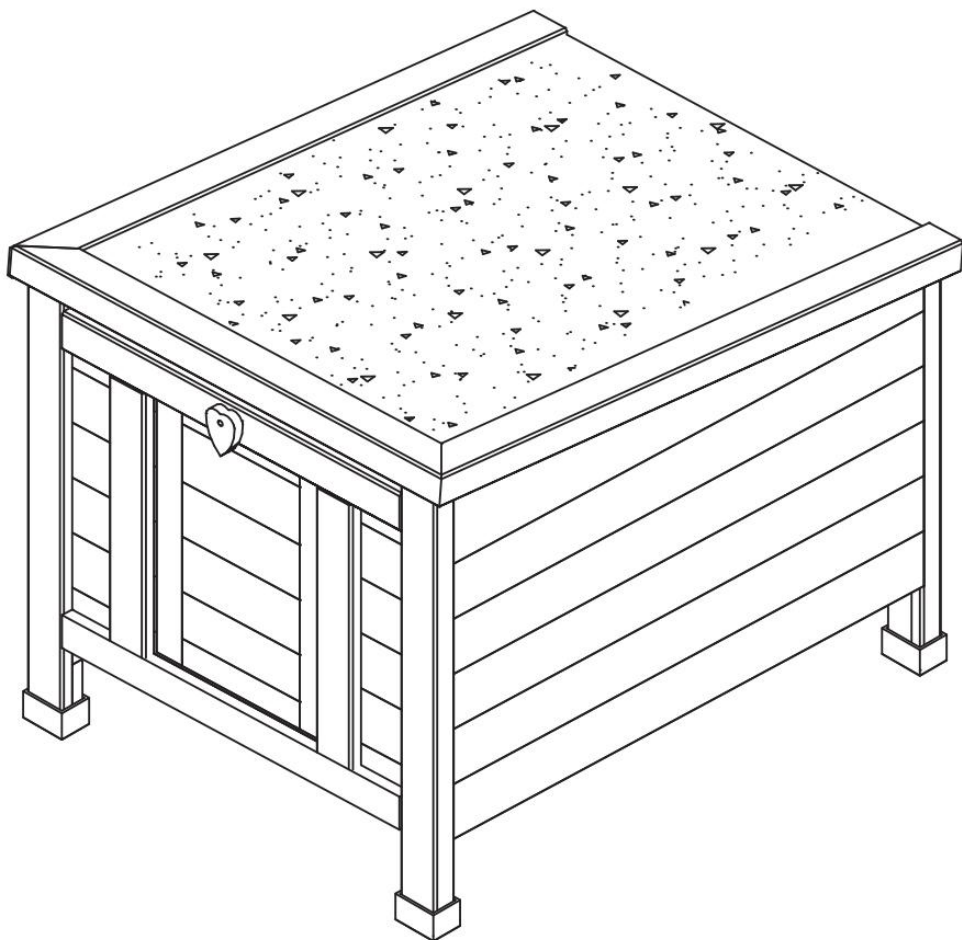

Die Montage ist abgeschlossen .

**Hersteller :** Shanghai muxinmuyeyouxiangongsi

**Adresse:** Shuangchenglu 803nong11hao1602A-1609shi, Baoshanqu, Shanghai 200000 CN.

**Nach AUS importiert:** SIHAO PTY LTD. 1 ROKEVA  
STREETEASTWOOD NSW 2122 Australien

**Importiert in die USA:** Sanven Technology Ltd. Suite 250, 9166 Anaheim  
Ort, Rancho Cucamonga, CA 91730

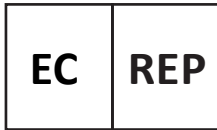

E-CrossStu GmbH

Mainzer Landstr.69, 60329 Frankfurt am Main.



YH CONSULTING LIMITED.

C/O YH Consulting Limited Office 147, Centurion House,  
London Road, Staines-upon-Thames, Surrey, TW18 4AX



**STYLE D'ARMOIRE EN BOIS**  
**REFUGE POUR CHATS**  
**MANUEL DE L'UTILISATEUR**

# CABINET STYLE WOODEN CAT SHELTER

DUSCH2401

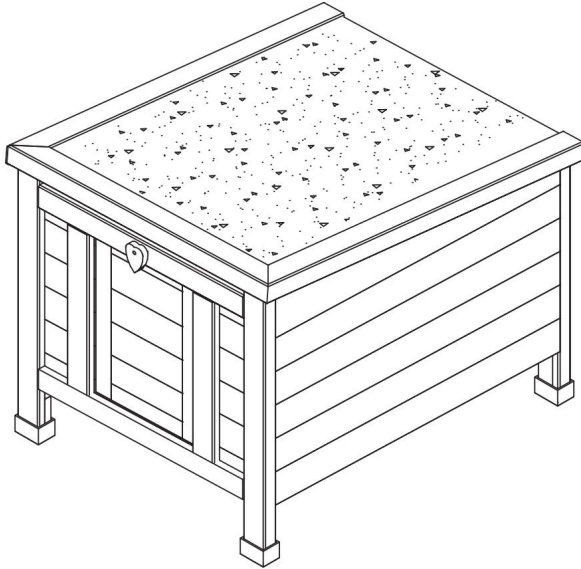

# Précautions de sécurité

## AVERTISSEMENT:

**Lisez ces instructions** avant d'utiliser ce produit. Ne pas le faire peut entraîner des blessures graves. les précautions de base doivent toujours être suivies , notamment les suivantes :

31. L' abri pour chat en bois de style armoire ne peut pas être utilisé ou stocké dans des zones dangereuses. Il est interdit d'utiliser l'appareil dans des endroits dangereux.
32. L' abri pour chat en bois de style armoire doit être vérifié pour s'assurer qu'il est en bon état de fonctionnement et qu'il fonctionne en toute sécurité avant utilisation. Dans le cas contraire , l'appareil ne doit pas être utilisé.
33. Veuillez garder le toit de l'abri en bois Kabinestell fermé, sinon cela provoquerait une infiltration d'eau.
34. Veuillez nettoyer régulièrement le fumier et les déchets dans la maison.
35. L'opérateur doit utiliser l' abri pour chat en bois de style armoire. correctement. Il doit tenir compte des conditions locales et doit faire attention aux tiers , en particulier aux enfants , lorsqu'il travaille avec l' abri pour chats en bois de style armoire .
36. Cet abri pour chat en bois de style armoire n'est pas destiné à être utilisé par des personnes (y compris des enfants) ayant des capacités physiques ,

sensorielles ou mentales réduites ou manquant d'expérience et/ou de connaissances , à moins qu'elles ne soient supervisées par une personne responsable de leur sécurité ou qu'elles ne soient instruites par ces personnes sur l'utilisation de le dispositif. Les enfants doivent être surveillés pour s'assurer qu'ils ne jouent pas avec le Abri pour chat en bois de style armoire .

## **CONSERVEZ CES INSTRUCTIONS**

### **Liste de produits**

---

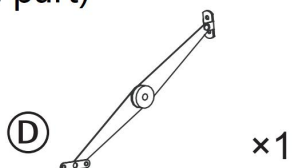
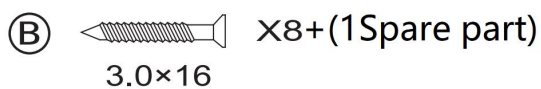
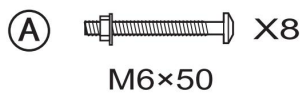
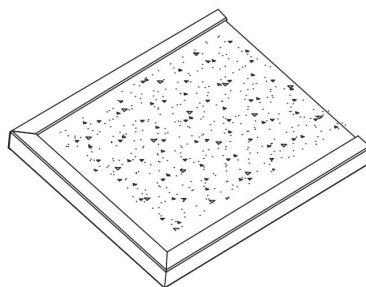
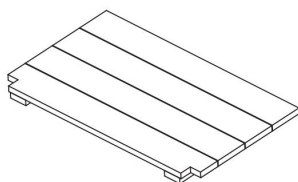
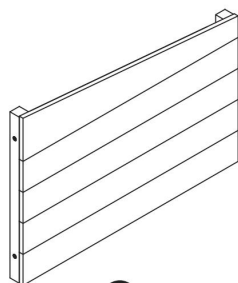
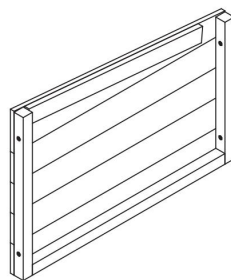
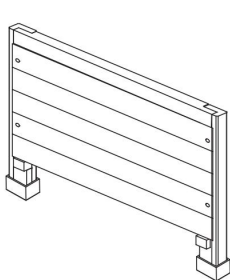
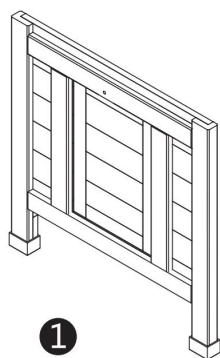

## Assemblage du produit

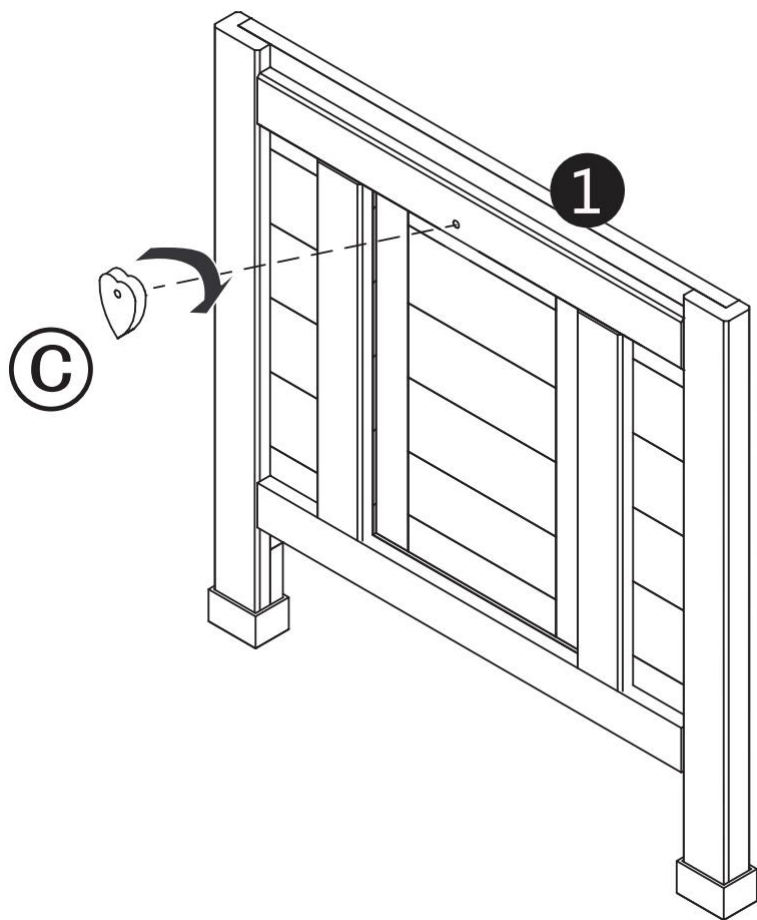

Assemblez la partie C par-dessus la 1.  
La partie C contrôle l'ouverture et la fermeture de la porte.

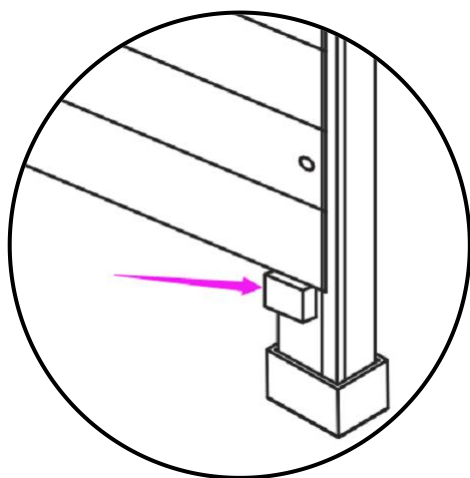
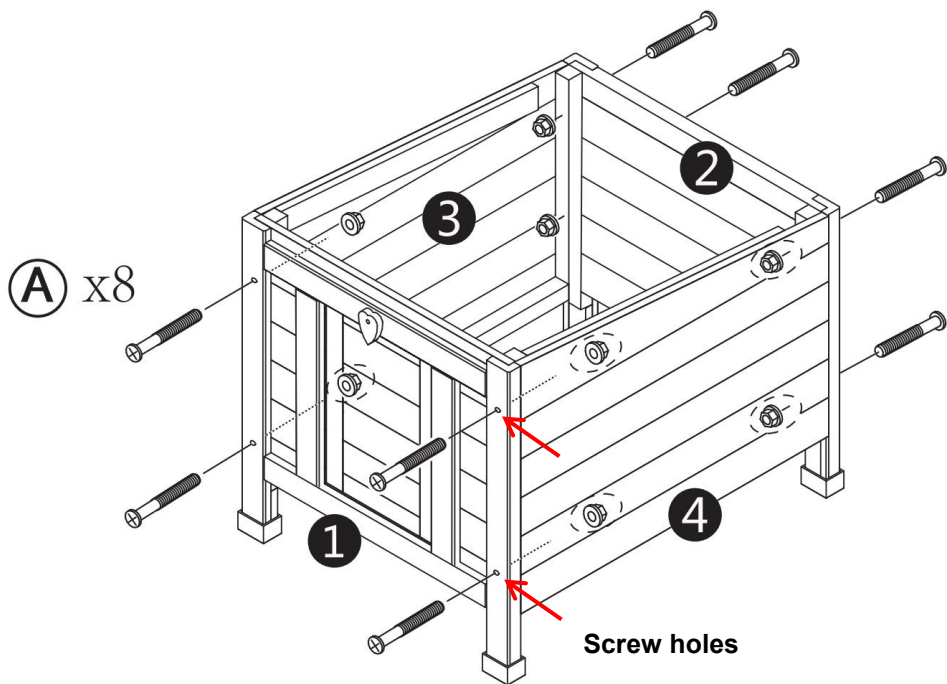

1 2 all have positioning pieces  
can be used and 3 4 for  
positioning assembly.

Assemblez et fixez (1, 2, 3 et 4) avec les vis A .

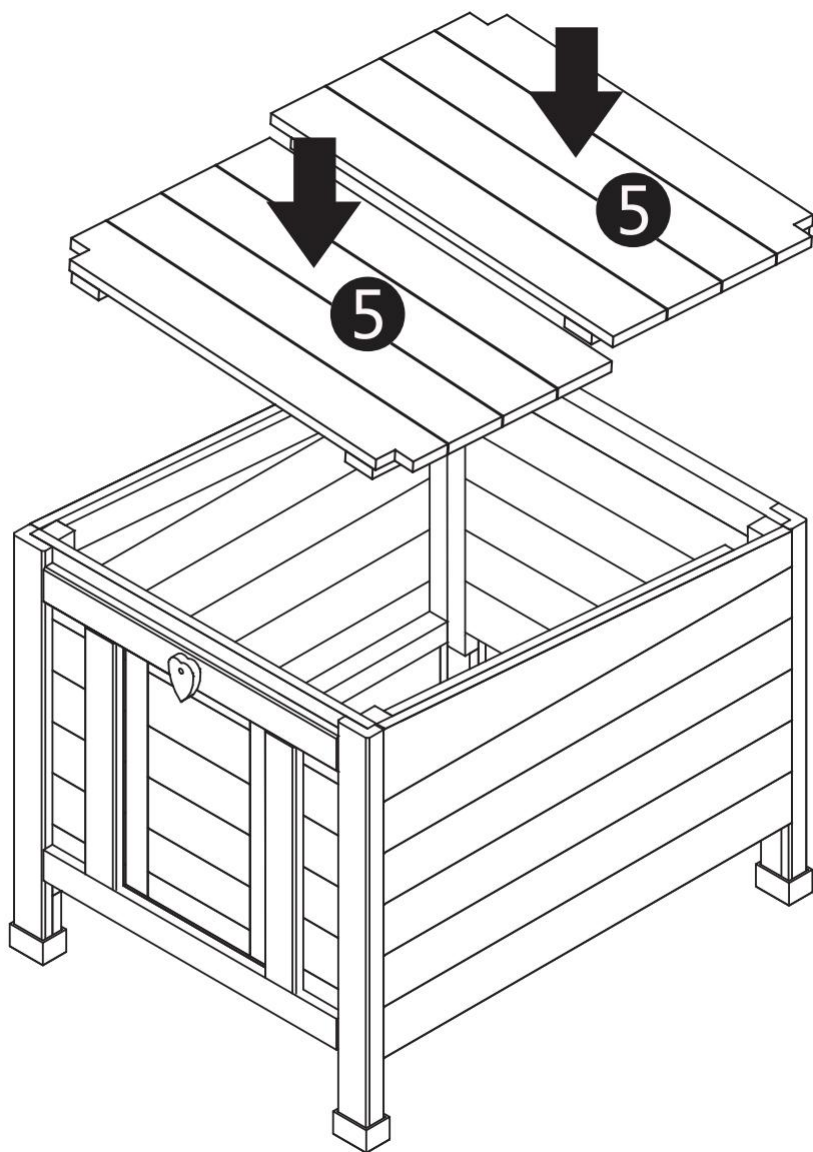

Mettez 5 dans le sens des flèches .

**Screw position marking**

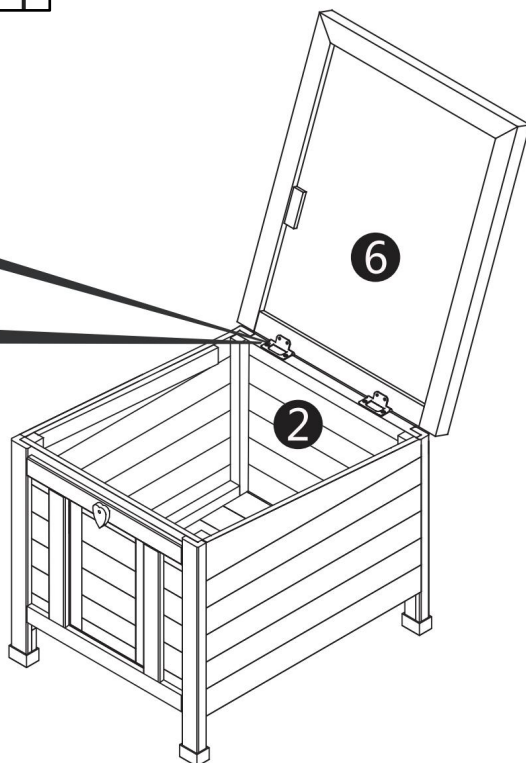
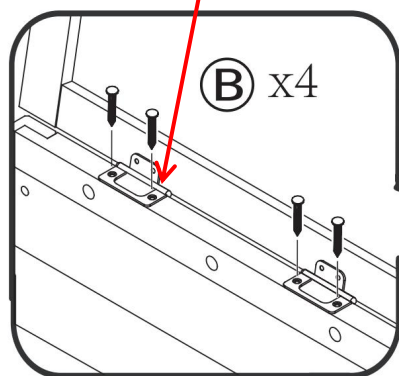
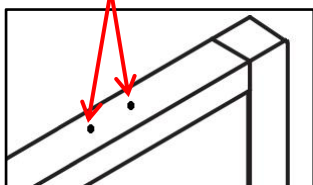

Assembler (8) sur la pièce avant avec la vis C .

**Remarque : Pour l'installation des vis, alignez les points d'identification de positionnement des vis sur les panneaux latéraux.**

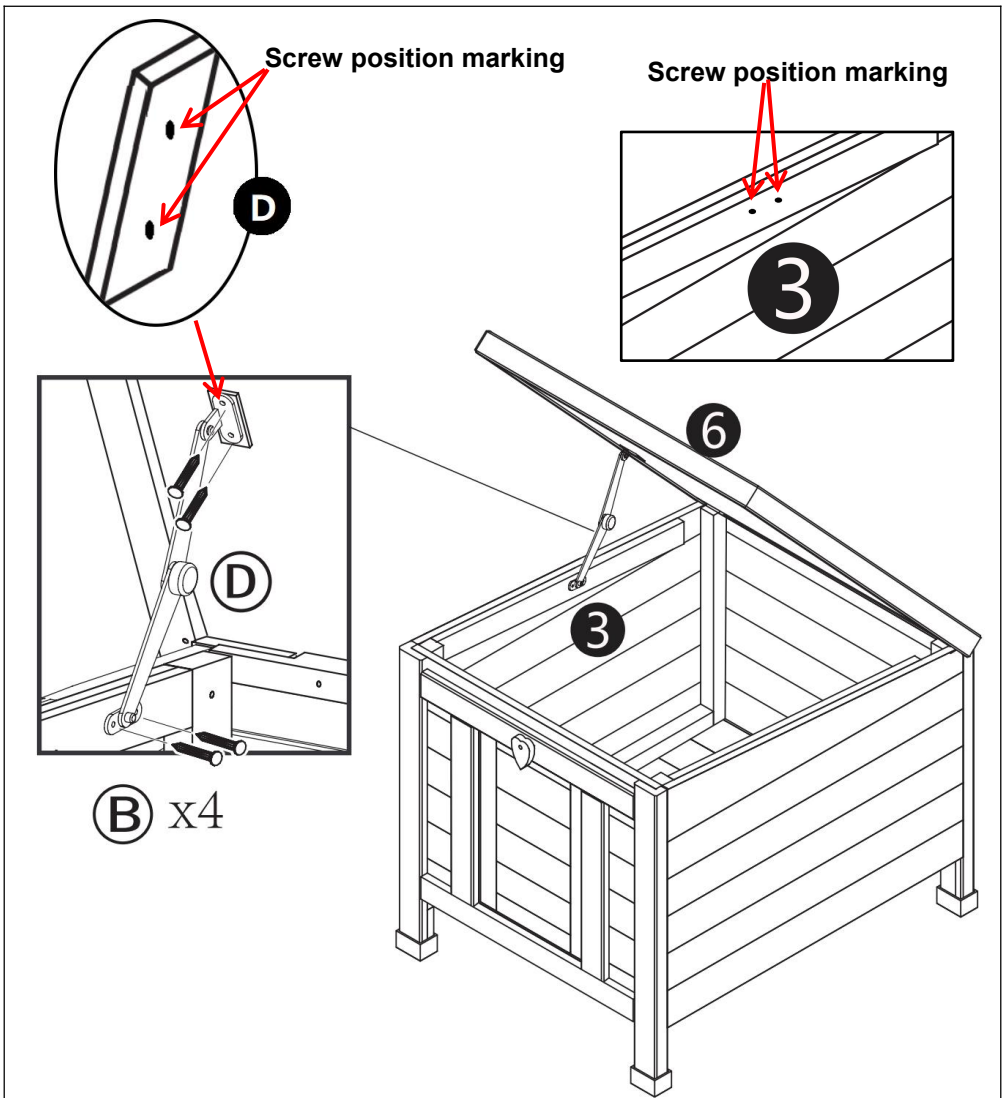

Assemblez les deux extrémités de (D) sur le toit et la tôle latérale gauche avec les vis B .

**Remarque : Pour l'installation des vis, alignez les points d'identification de positionnement des vis sur les panneaux latéraux.**

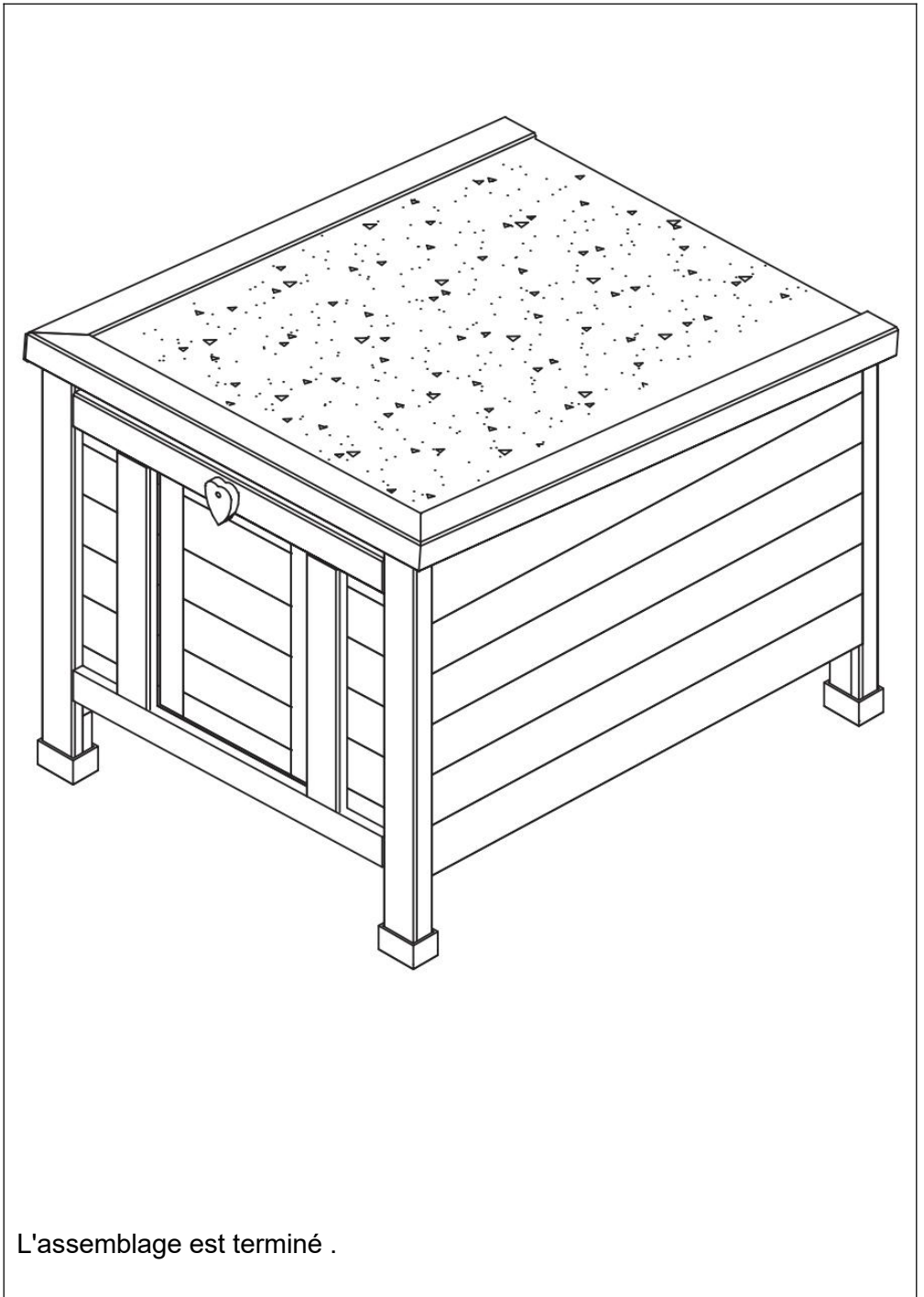

L'assemblage est terminé .

**Fabricant** : Shanghaimuxinmuyeyouxiangongsi

**Adresse** : Shuangchenglu 803nong11hao1602A-1609shi, baoshanqu, shanghai 200000 CN.

**Importé en Australie** : SIHAO PTY LTD. 1 ROKEVA STREETASTWOOD NSW 2122 Australie

**Importé aux États-Unis** : Sanven Technology Ltd. Suite 250, 9166 Anaheim

Lieu, Rancho Cucamonga, CA 91730

<b>EC</b>	<b>REP</b>
-----------	------------

E-CrossStu GmbH

Mainzer Landstr.69, 60329 Frankfurt am Main.

<b>UK</b>	<b>REP</b>
-----------	------------

YH CONSULTING LIMITED.

C/O YH Consulting Limited Office 147, Centurion House,  
London Road, Staines-upon-Thames, Surrey, TW18 4AX



**KABINETSTIJL HOUTEN**  
**KATTENOPVANG**  
**HANDLEIDING**

# CABINET STYLE WOODEN CAT SHELTER

DUSCH2401

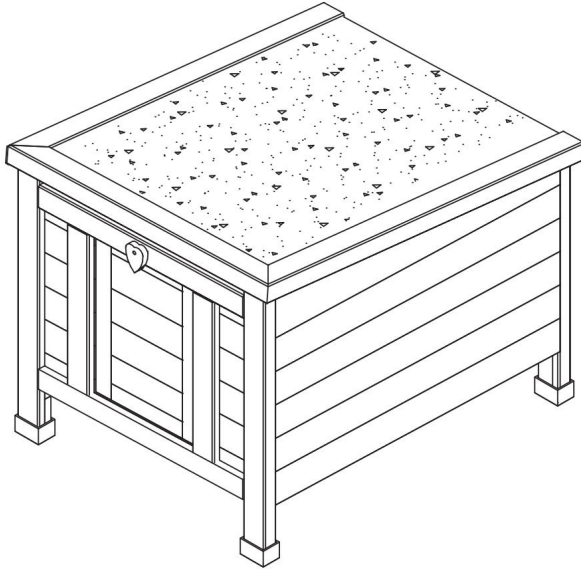

This is the original instruction, please read all manual instructions carefully before operating. reserves a clear interpretation of our user manual. The appearance of the product shall be subject to the product you received. Please forgive us that we won't inform you again if there are any technology or software updates on our product.

## Veiligheidsmaatregelen

### WAARSCHUWING:

**Lees deze instructies** voordat u dit product gebruikt. Als u dit niet doet, kan dit leiden tot ernstig letsel. de basisvoorzorgsmaatregelen moeten altijd worden gevolgd , waaronder de volgende:

37. Het houten kattenhok in kaststijl mag niet worden gebruikt of opgeslagen in gevaarlijke gebieden. Het is niet toegestaan het apparaat op gevaarlijke locaties te gebruiken.

38. Het houten kattenhok in kaststijl moet vóór gebruik worden gecontroleerd om er zeker van te zijn dat deze in goede staat verkeert en veilig werkt. Anders mag het apparaat niet worden gebruikt.

39. Houd het dak van de Kabinestell Wooden Carter Shelter gesloten, anders kan er water binnendringen.

40. Ruim regelmatig de mest en het afval in huis op.

41. De exploitant moet het houten kattenhok in kaststijl gebruiken op de juiste manier. Hij moet rekening houden met de plaatselijke omstandigheden en moet letten op derden , in het bijzonder kinderen , wanneer hij met het houten kattenasiel Kaststijl werkt .

42. Dit houten kattenhok in kaststijl is niet bedoeld voor gebruik door personen (inclusief kinderen) met verminderde lichamelijke , zintuiglijke of geestelijke

vermogens of gebrek aan ervaring en/of kennis , tenzij zij onder toezicht staan van een persoon die verantwoordelijk is voor hun veiligheid of door deze personen zijn geïnstrueerd over het gebruik van het apparaat. Op kinderen moet toezicht worden gehouden , om er zeker van te zijn dat ze niet met het apparaat spelen  
Houten kattenhok in kaststijl .

## **BEWAAR DEZE INSTRUCTIES**

### **Product lijst**

---

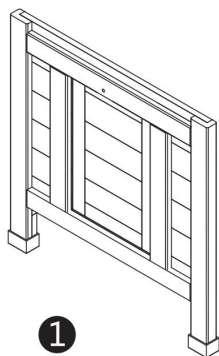

1

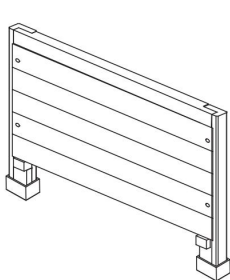

2

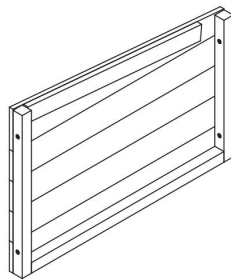

3

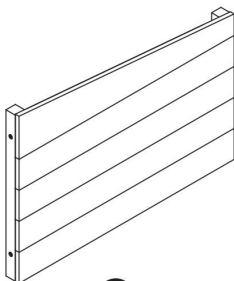

4

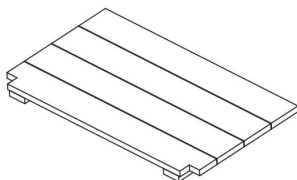

5 X2

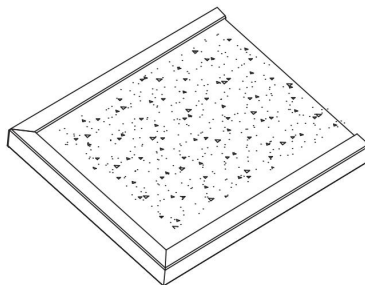

6

(A)  X8  
M6x50

(B)  X8+(1Spare part)  
3.0x16

(C)  X1

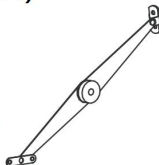
(D)  X1

## Product A montage

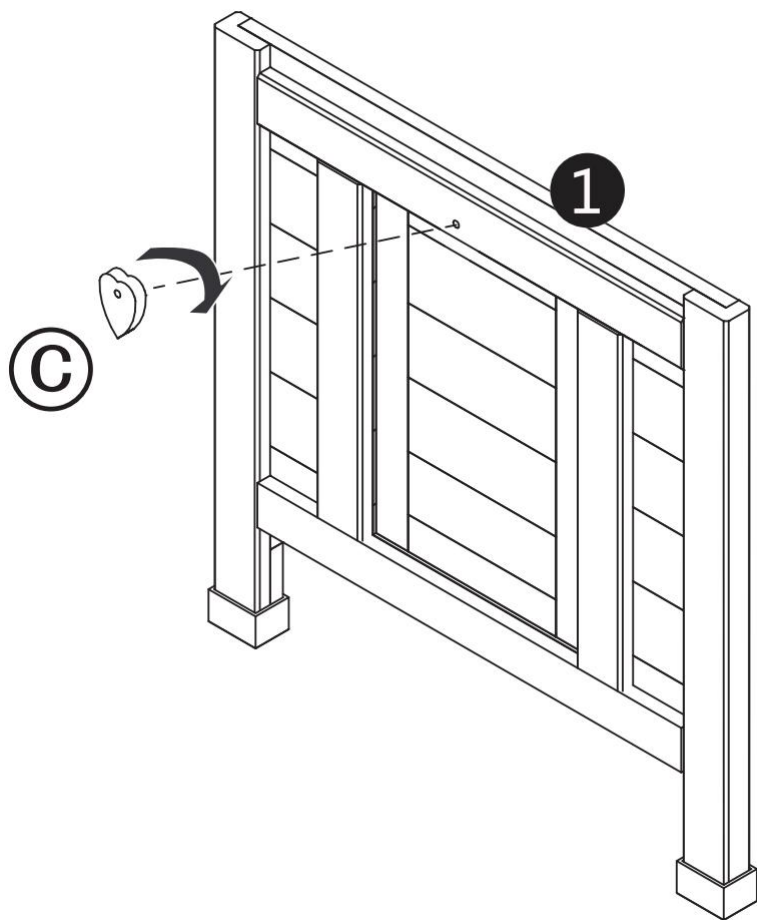

Monteer onderdeel C bovenop 1.  
Deel C regelt het openen en sluiten van de deur.

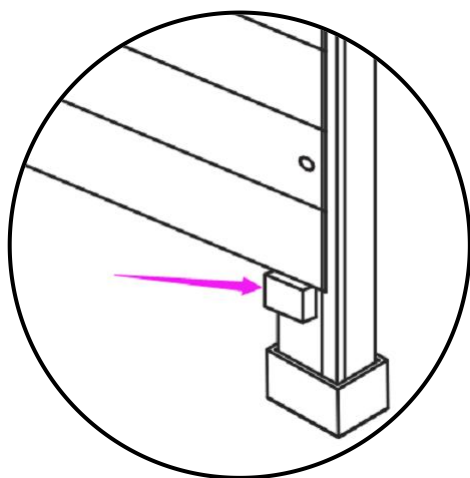
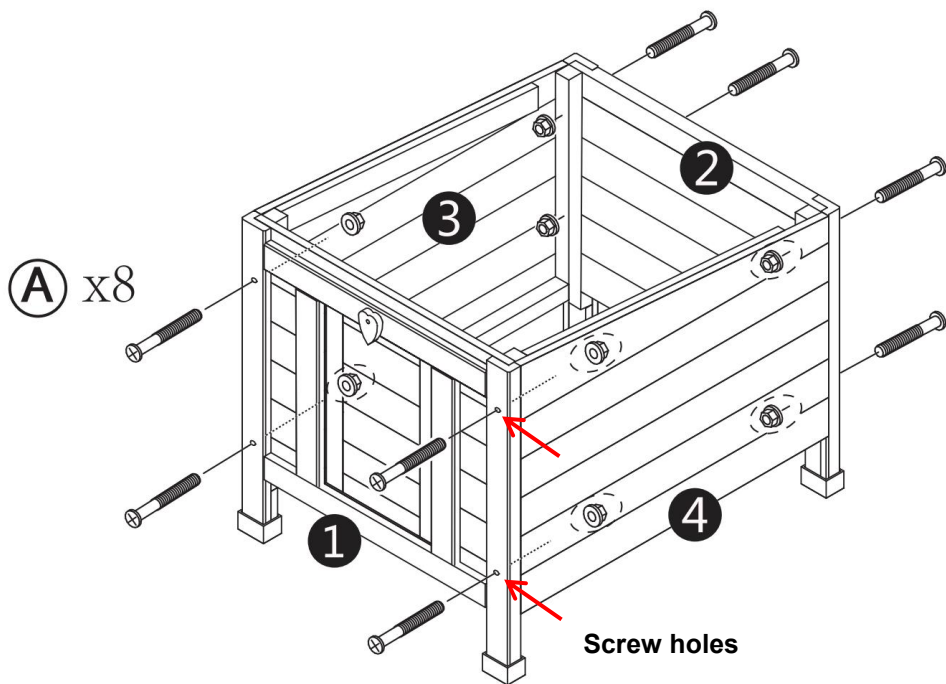

1 2 all have positioning pieces  
can be used and 3 4 for  
positioning assembly.

Monteer en bevestig (1, 2, 3 en 4) met schroeven A .

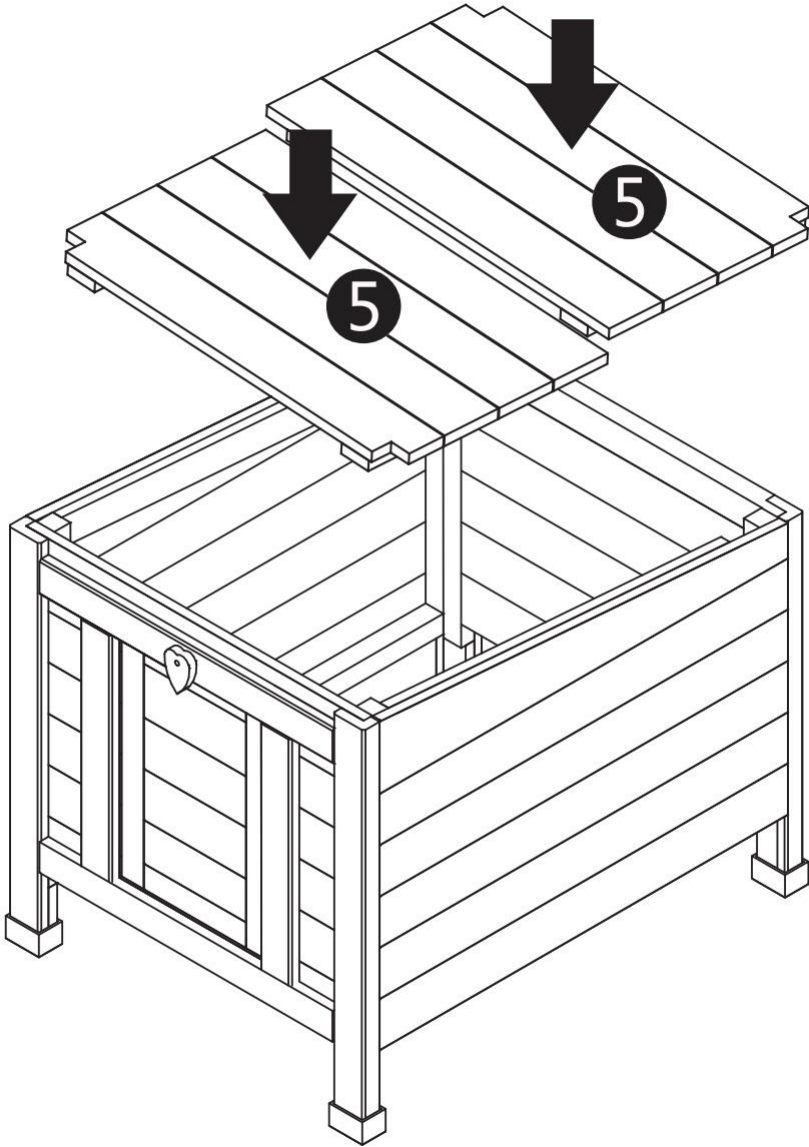

Zet 5 in de richting van de pijlen .

### Screw position marking

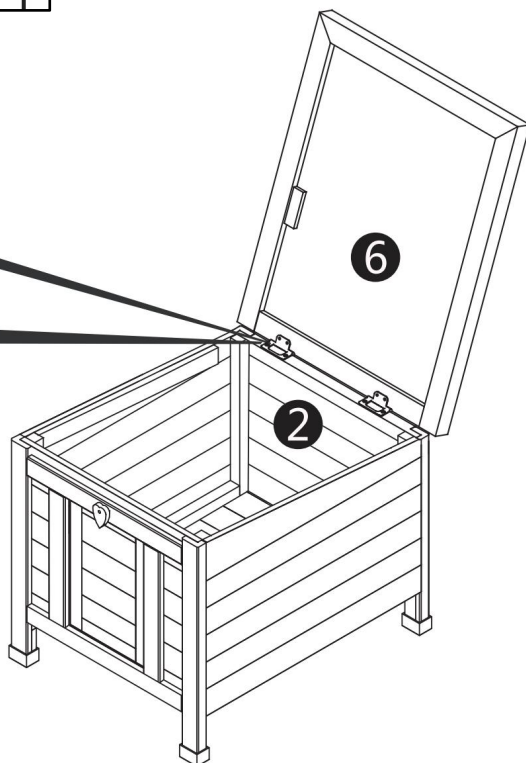
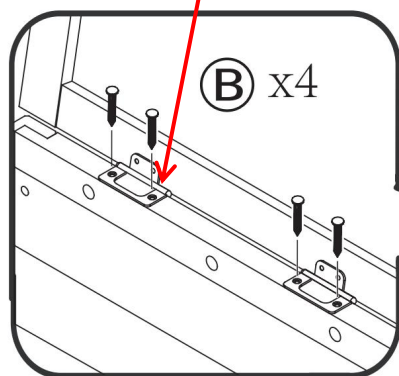
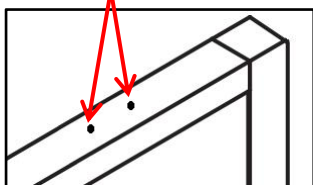

Monteer (8) op het voorstuk met bout C .

**Opmerking: Voor het installeren van schroeven lijnt u de identificatiepunten voor de schroefpositie op de zijpanelen uit.**

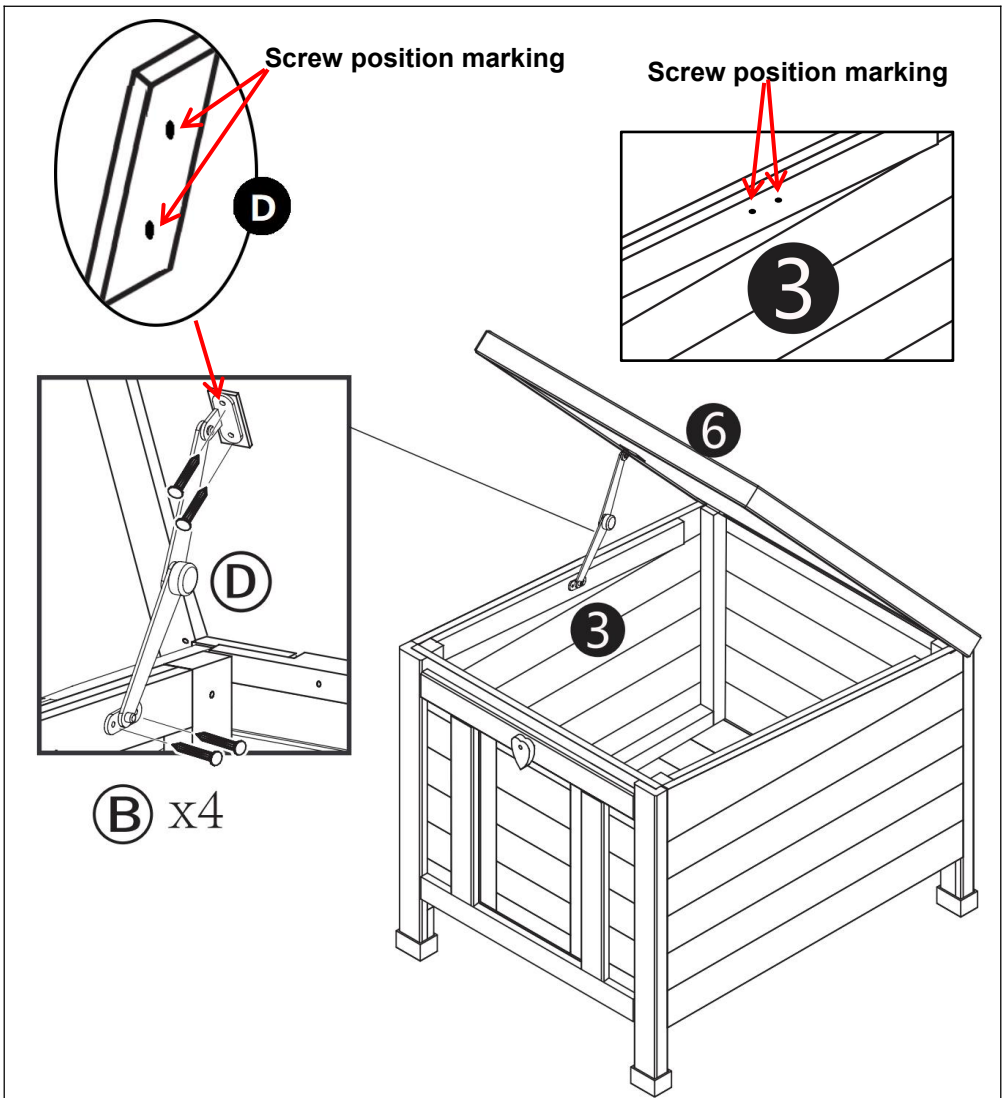

Monteer de twee uiteinden van (D) op het dak en de linkerzijplaat met schroeven B .

**Opmerking: Voor het installeren van schroeven lijnt u de identificatiepunten voor de schroefpositie op de zijpanelen uit.**

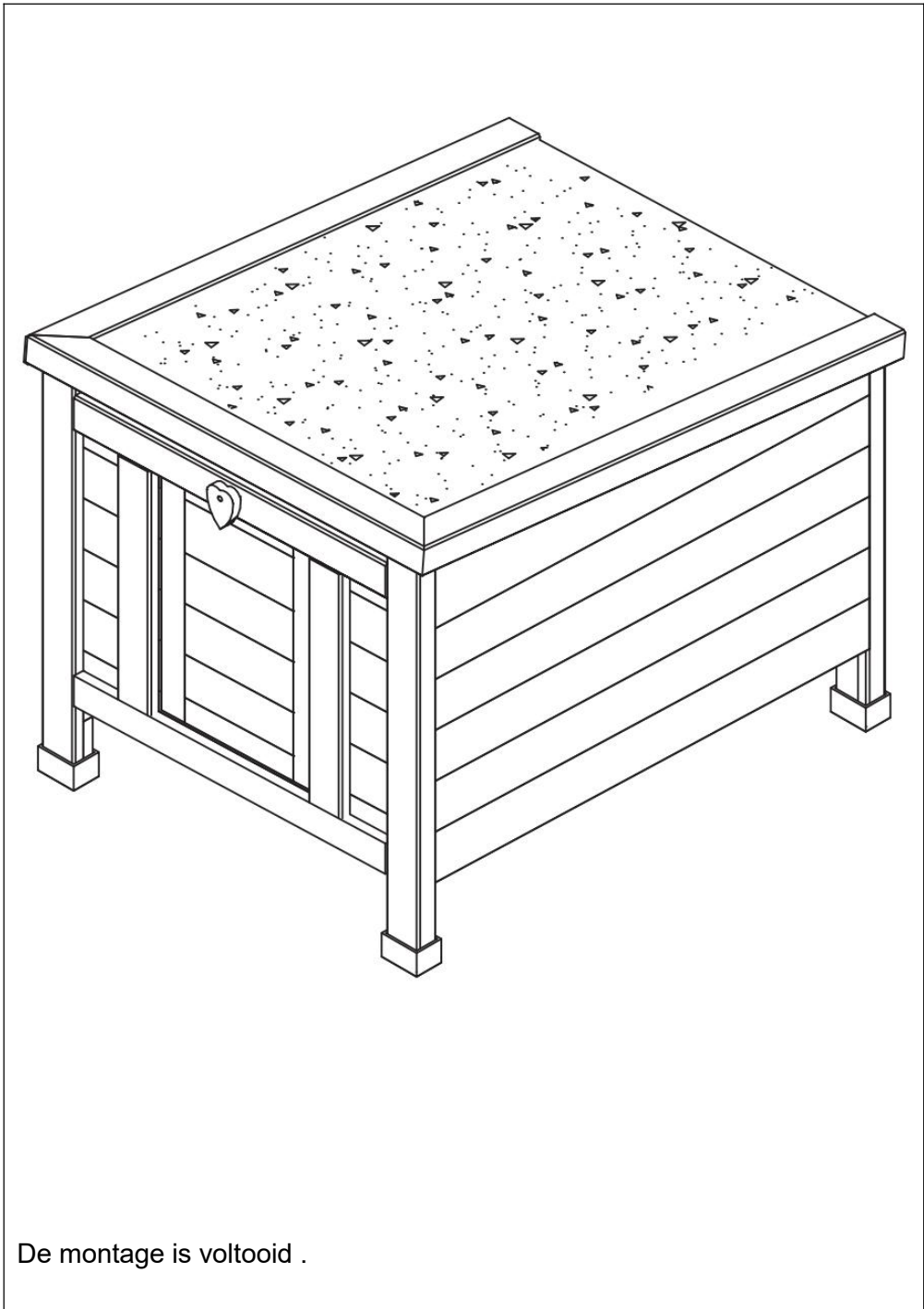

De montage is voltooid .

**Fabrikant :** Shanghaimuxinmuyeyouxiangongsi

**Adres:** Shuangchenglu 803nong11hao1602A-1609shi, baoshanqu, shanghai 200000 CN.

**Geïmporteerd naar AUS:** SIHAO PTY LTD. 1 ROKEVA  
STREETEASTWOOD NSW 2122 Australië

**Geïmporteerd in de VS:** Sanven Technology Ltd. Suite 250, 9166  
Anaheim

Plaats, Rancho Cucamonga, CA 91730

<b>EC</b>	<b>REP</b>
-----------	------------

E-CrossStu GmbH

Mainzer Landstr.69, 60329 Frankfurt am Main.

<b>UK</b>	<b>REP</b>
-----------	------------

YH CONSULTING LIMITED.

C/O YH Consulting Limited Office 147, Centurion House,  
London Road, Staines-upon-Thames, Surrey, TW18 4AX



**TRÄ I SKÅPSTIL**  
**KATTHEM**  
**ANVÄNDARMANUAL**

# CABINET STYLE WOODEN CAT SHELTER

DUSCH2401

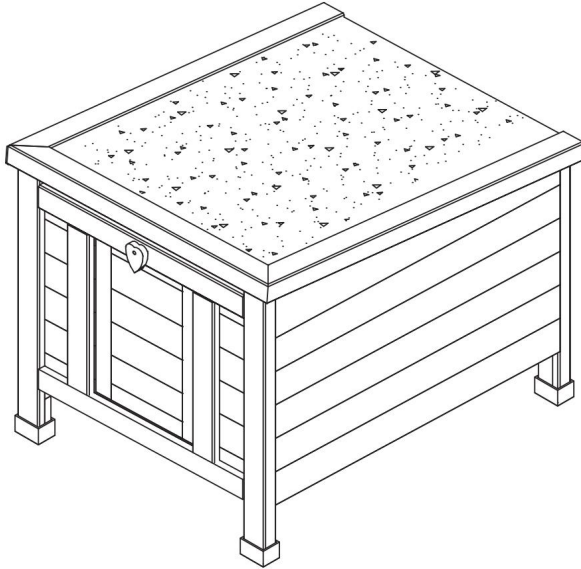

# Säkerhetsåtgärder

## VARNING:

**Läs dessa instruktioner** innan du använder denna produkt. Underlåtenhet att göra det kan resultera i allvarliga skador. de grundläggande försiktighetsåtgärderna bör alltid följas , inklusive följande:

43. The Cabinet Style Wooden Cat Shelter får inte användas eller förvaras i farliga områden. Det är inte tillåtet att använda apparaten på farliga platser.

44. The Cabinet Style Wooden Cat Shelter måste kontrolleras för att säkerställa att den är i korrekt fungerande skick och fungerar säkert före användning. I annat fall får apparaten inte användas.

45. Vänligen håll Kabinestall Wooden Carter Shelter-taket stängt, annars kommer det att orsaka vatteninträngning.

46. Städa upp gödsel och sopor i huset regelbundet.

47. Operatören måste använda ett katthem i trä i skåpstil ordentligt. Han måste ta hänsyn till de lokala förhållandena och måste vara uppmärksam på tredje part , särskilt barn , när han arbetar med Cabinet Style Wooden Cat Shelter .

48. Detta katthem i trä i skåpstil är inte avsedd att användas av personer (inklusive barn) med nedsatta fysiska , sensoriska eller mentala förmågor eller som saknar erfarenhet och/eller kunskap, såvida de inte övervakas av en person som ansvarar för deras säkerhet eller instrueras av dessa personer om

användningen av enheten. Barn bör övervakas för att säkerställa att de inte leker med Kattsydd i skåpstil i trä .

## **SPARA DESSA INSTRUKTIONER**

### **Produktlista**

---

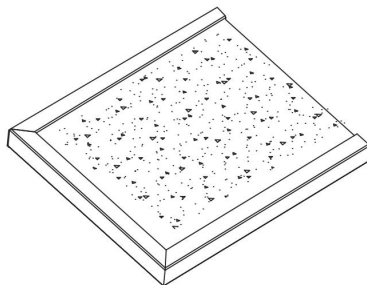
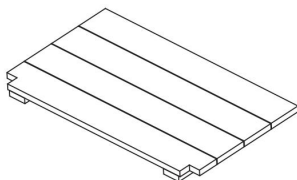
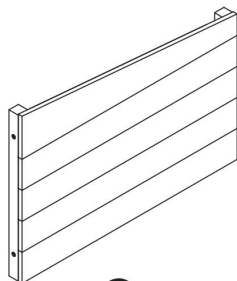
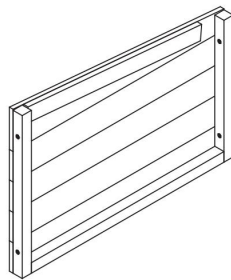
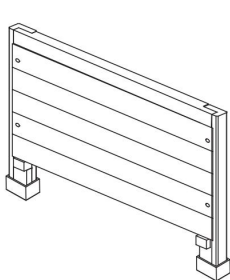
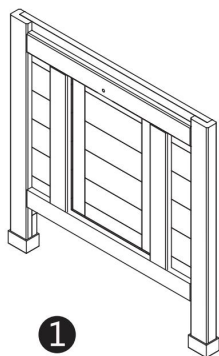

(A)  X8  
M6x50

(B)  X8+(1Spare part)  
3.0x16

(C)  x1

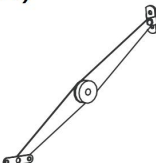
(D)  x1

## Produkt En sammanställning

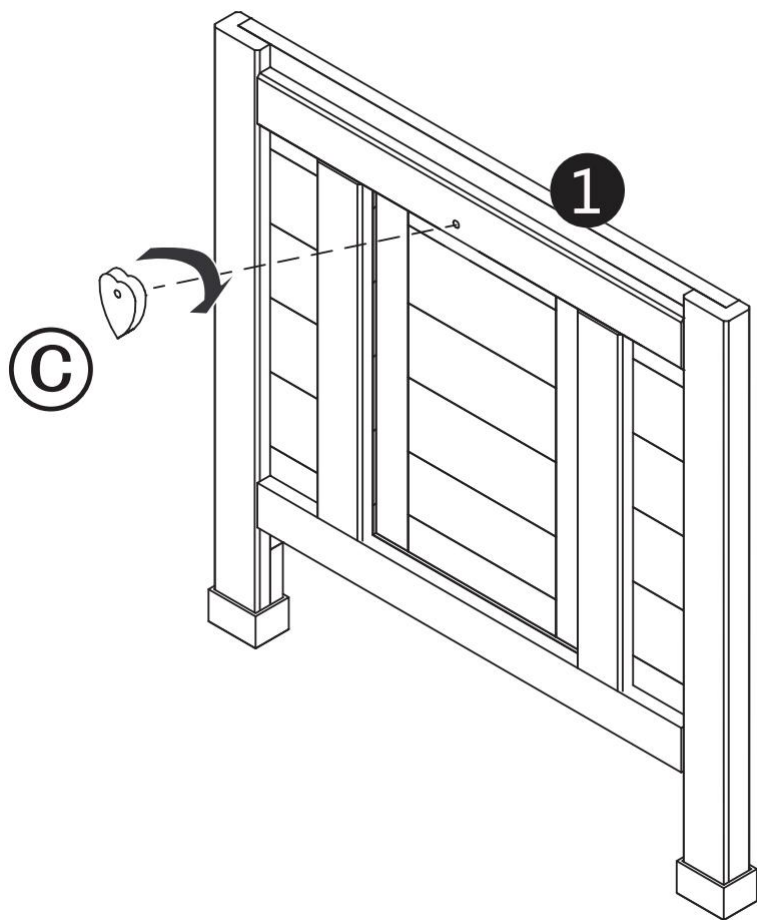

Montera del C ovanpå 1.  
Del C styr öppning och stängning av dörren.

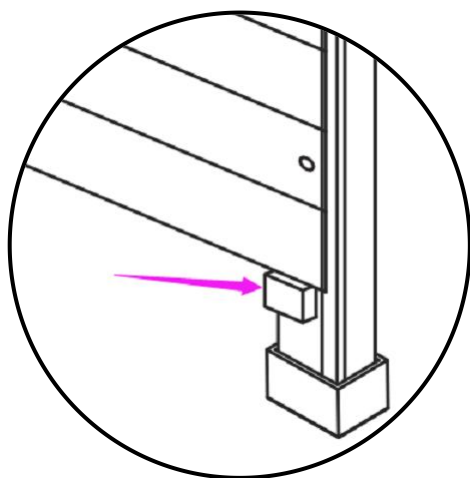
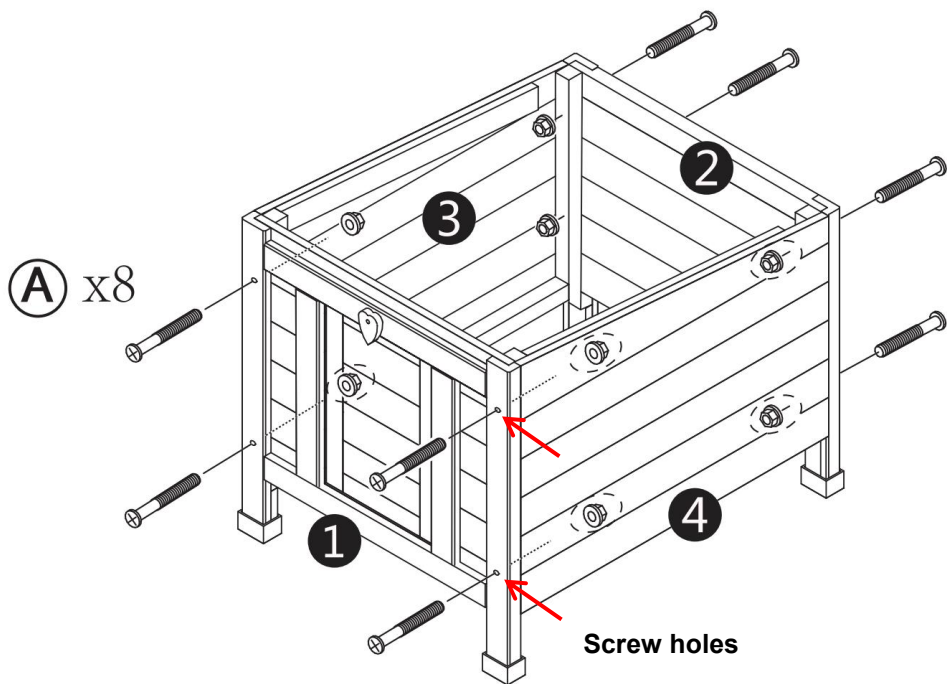

1 2 all have positioning pieces  
can be used and 3 4 for  
positioning assembly.

Montera och fixera (1, 2, 3 och 4) med skruvarna A .

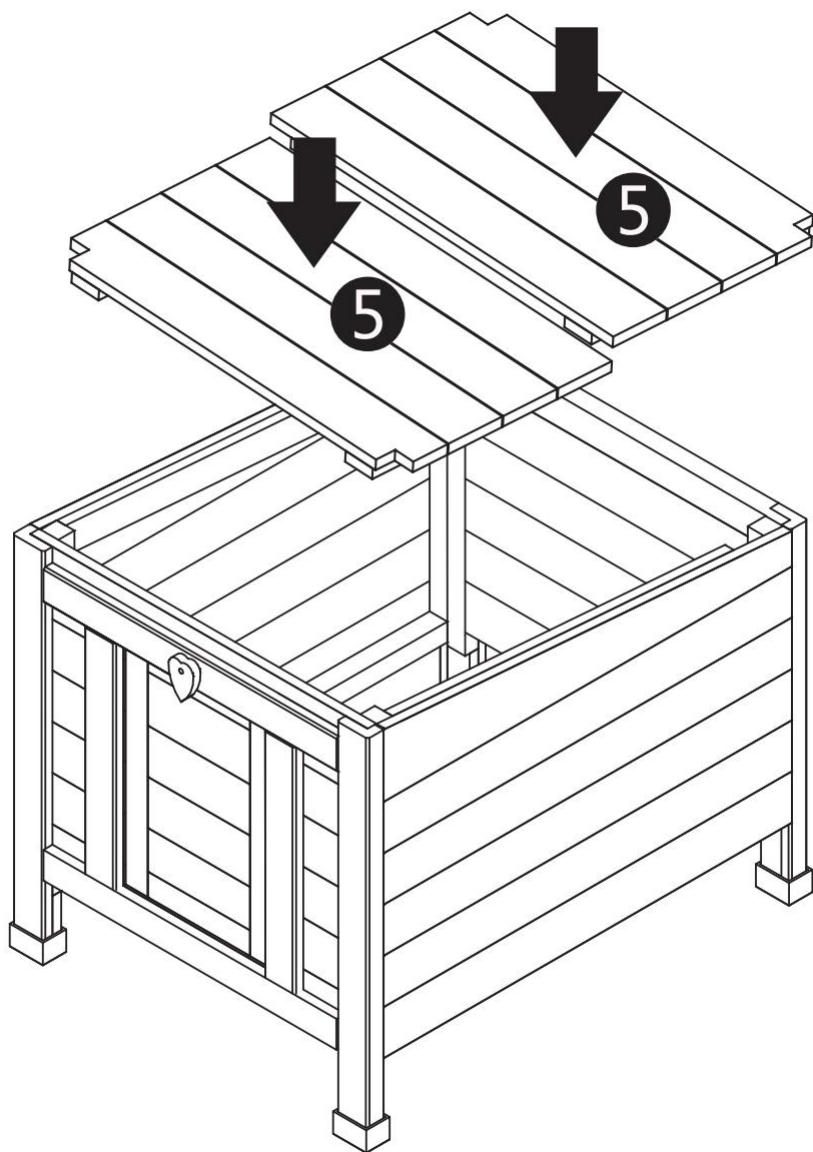

Sätt 5 i pilarnas riktning .

**Screw position marking**

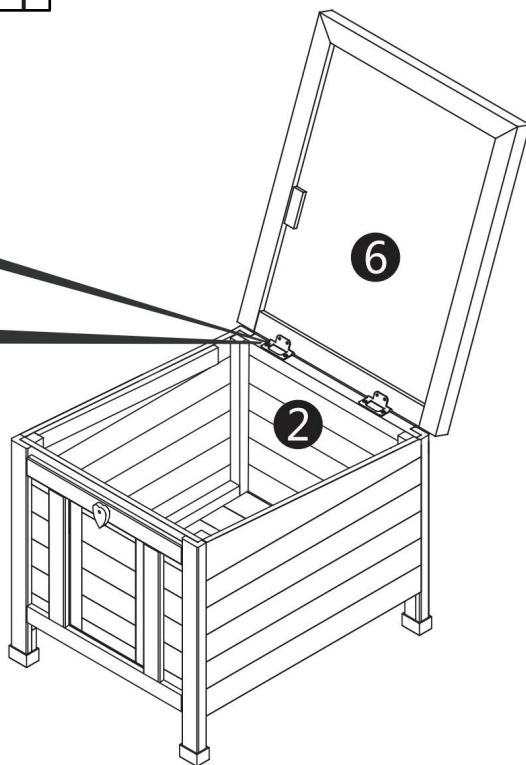
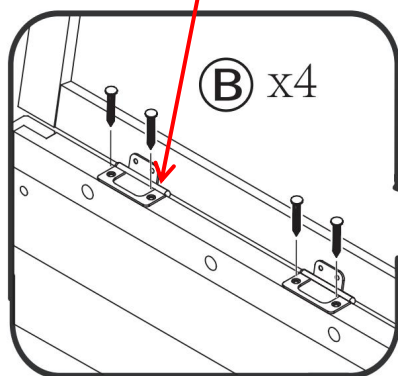
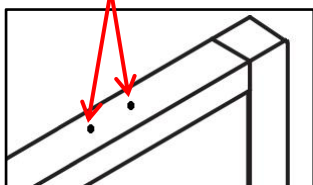

Montera (8) på framstycket med bult C .

**Obs: För skruvinstitution, rikta in skruvplaceringsidentifieringspunkterna på sidopanelerna.**

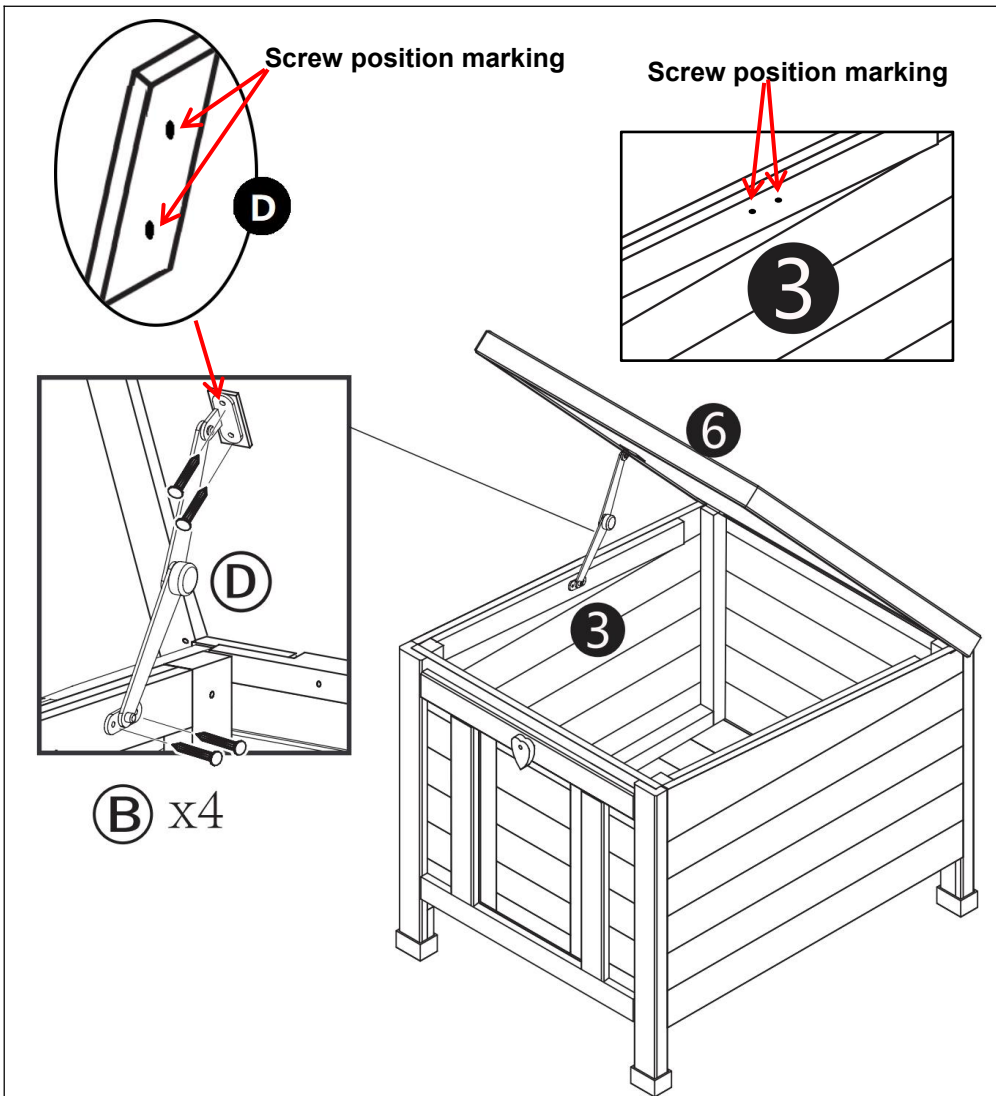

Montera de två ändarna av (D) på taket och den vänstra sidoplattan med skruvar B .

**Obs:** För skruvinstallation, rikta in skruvplaceringsidentifieringspunkterna på sidopanelerna.

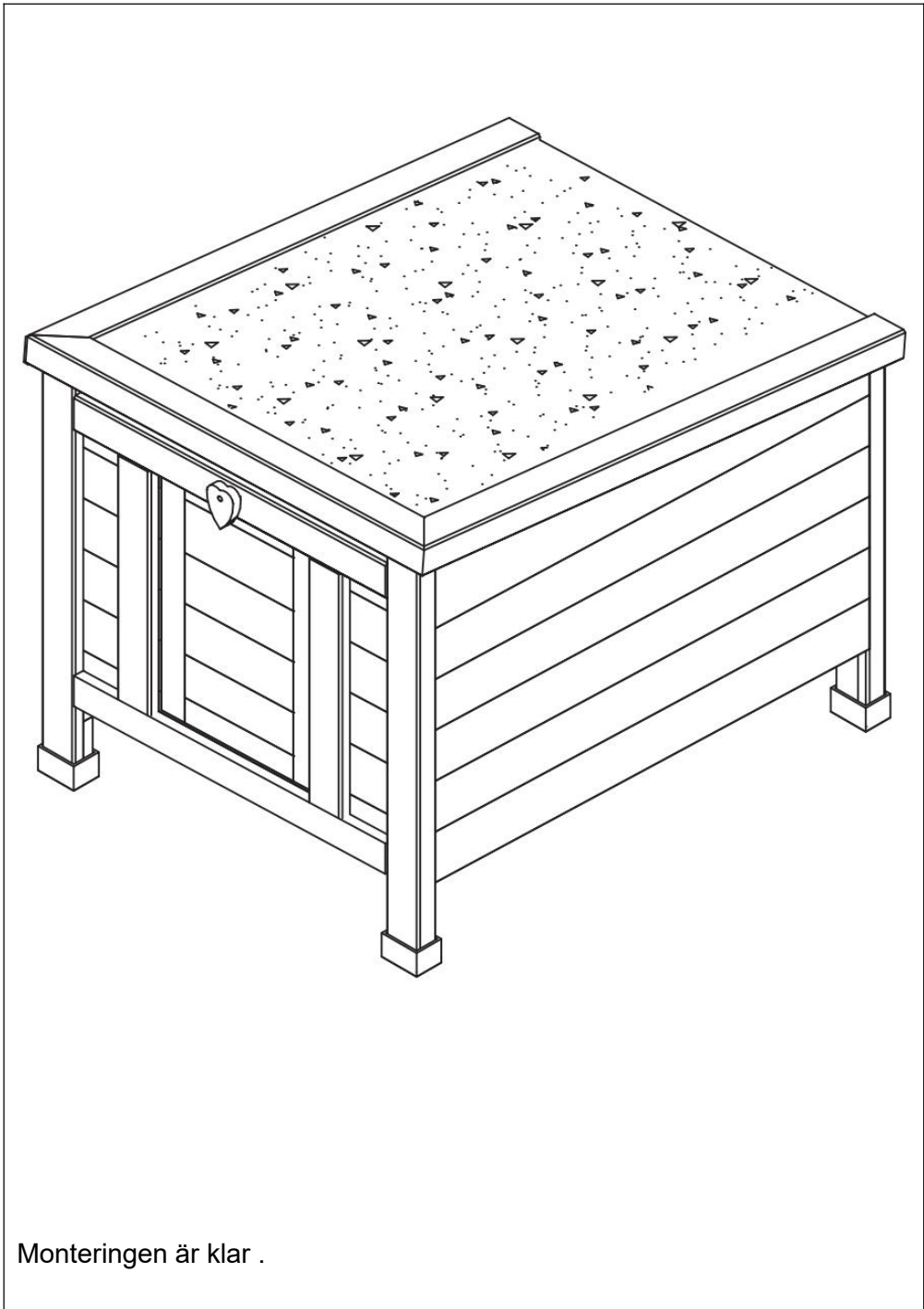

Monteringen är klar .

**Tillverkare :** Shanghaimuxinmuyeyouxiangongsi

**Address:** Shuangchenglu 803nong11hao1602A-1609shi, baoshanqu, shanghai 200000 CN.

**Importerad till AUS:** SIHAO PTY LTD. 1 ROKEVA STREETEASTWOOD NSW 2122 Australien

**Importerad till USA:** Sanven Technology Ltd. Suite 250, 9166 Anaheim Place, Rancho Cucamonga, CA 91730

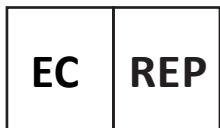

E-CrossStu GmbH

Mainzer Landstr.69, 60329 Frankfurt am Main.



YH CONSULTING LIMITED.

C/O YH Consulting Limited Office 147, Centurion House,  
London Road, Staines-upon-Thames, Surrey, TW18 4AX

