

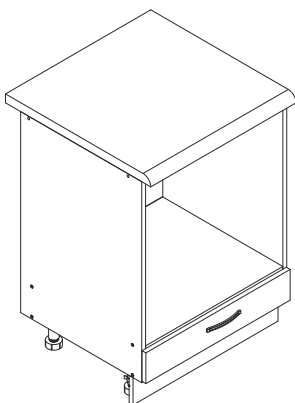

Szafka SDP60 (60x60x82)



Ilość potrzebnych osób
Number of people needed
Benötigte Personenzahl
Nombre de personnes nécessaires

Niezbędne narzędzia do montażu
Tools necessary for assembly

Notwendiges Werkzeug für die Montage
Outils nécessaires pour le montage

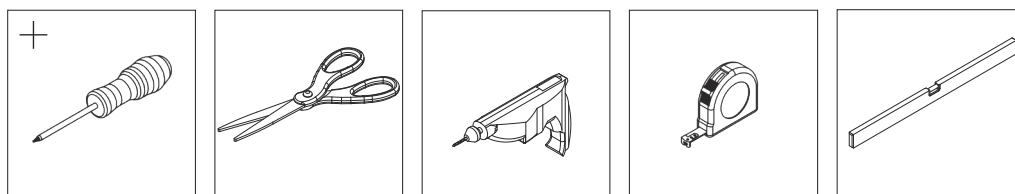

PL

- Przed przystąpieniem do montażu przeczytaj i zapoznaj się z całą instrukcją.
- Przestrzegaj bezwzględnie kolejnych kroków montażowych **1**, **2**, **3**...
- Nie wyrzucaj opakowania dopóki nie ukończysz skutecznie w całości montażu.
- Montaż wykonuj na płaskiej, miękkiej oraz czystej powierzchni takiej jak tektura.
- Bezwzględnie nie montuj elementów jeśli zauważysz ich wady lub uszkodzenia.
- Elementy montażowe takie jak okucia trzymaj w miejscu niedostępnym dla niemowląt i dzieci.
- Wadliwe lub uszkodzone elementy reklamuj podając ich numer z instrukcji montażu.
- Jeśli uszkodzony element będzie zamontowany reklamacja nie będzie uznana.

EN

- Read and get familiar with the whole instruction before the process of installation.
- Imperatively observe the consecutive assembly steps **1**, **2**, **3**...
- Do not throw away the packaging until the installation is successfully done.
- The installation should be done on the flat, soft and clear surface, such as cardboard.
- Under no circumstances should you install the elements in case of any faults or damage.
- The installation elements as fittings should be kept in a place unavailable for babies or children.
- Faulty or damaged components should be complaint by giving the number of the assembly instruction.
- If the damaged component is installed, the complaint will not be accepted.

DE

- Vor Beginn der Montage muss man die Instruktion genau durchlesen.
- Die aufeinanderfolgenden Montageschritte **1**, **2**, **3**... unbedingt beachten.
- Man muss die Packung behalten bis man die ganze Montage erfolgreich nicht beendet.
- Die Montage muss man auf einer glatten, weichen und sauberen Fläche ausüben
- Fehlerhafte oder beschädigte Elemente darf man auf keinen Fall montieren. Auf keinen Fall darf man fehlerhafte oder beschädigte Elemente montieren.
- Die Montageelemente wie Beschläge muss man unzugänglich von Babys und Kindern halten.
- Fehlerhafte oder beschädigte Elemente muss man nur mit Nummer der Instruktion reklamieren.
- Falls das beschädigte Element montiert wird, wird die Reklamation nicht berücksichtigt.

FR

- Avant de commencer le montage, lire et prendre connaissance de l'intégralité du manuel.
- Respectez scrupuleusement les étapes d'installation suivantes **1**, **2**, **3**...
- Ne pas jeter l'emballage avant d'avoir terminé l'assemblage.
- Le montage doit être effectué sur une surface plane, souple et propre, comme du carton.
- Ne pas assembler si vous remarquez des défauts ou des dommages.
- Garder les éléments de montage tels que les raccords hors de portée des bébés et des enfants.
- Réclamer les pièces défectueuses ou endommagées en citant le numéro figurant dans les instructions de montage.
- Si l'article endommagé est installé, la plainte ne sera pas acceptée.

SZAFKA SDP60

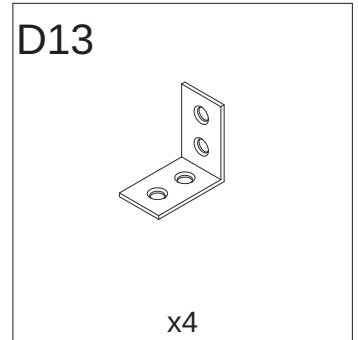
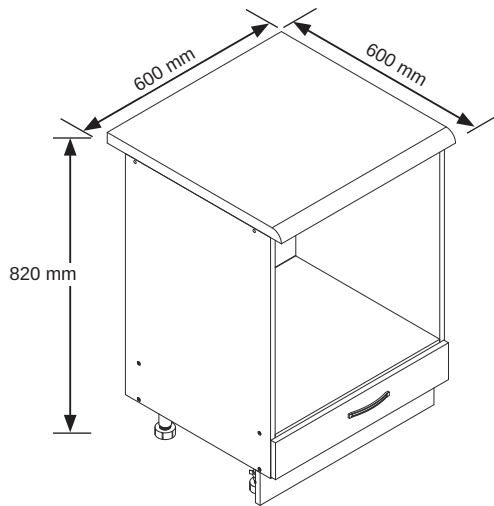

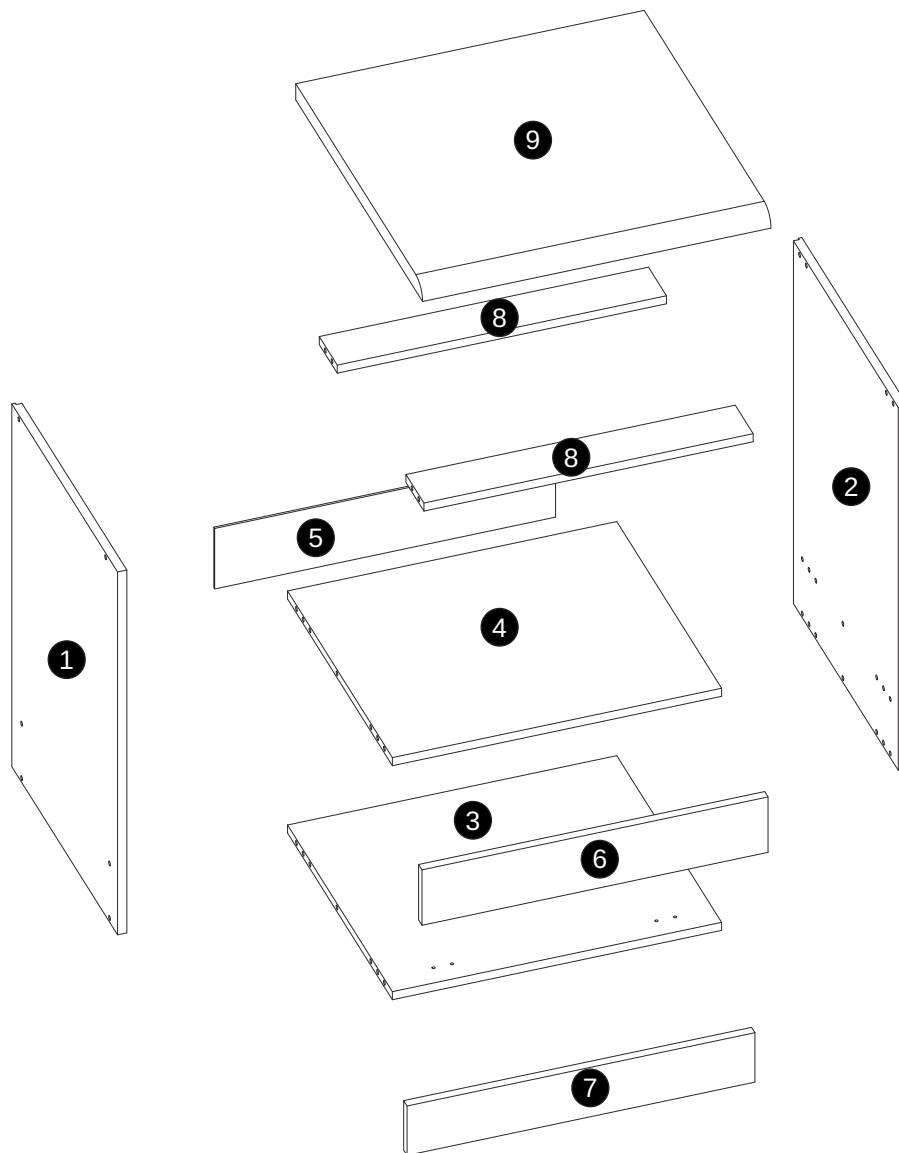

Okucia / Fittings / Beschläge / Embouts

<p>E1</p> <p>x24</p>	<p>U1</p> <p>x1</p>	<p>F1</p> <p>7x50mm</p> <p>x12</p>	<p>P9</p> <p>4x27mm</p> <p>x2</p>
<p>A1</p> <p>x2</p>	<p>K2</p> <p>x1</p>	<p>S1c</p> <p>3,5x16mm</p> <p>x36</p>	<p>U5</p> <p>x4</p>
<p>S0b</p> <p>3x16mm</p> <p>x8</p>	<p>U6</p> <p>x2</p>	<p>U7</p> <p>x2</p>	<p>F10</p> <p>x12</p>
<p>B1</p> <p>x1</p>	<p>R1</p> <p>x1</p>	<p>D12</p> <p>x4</p>	<p>S4b</p> <p>4x30mm</p> <p>x4</p>

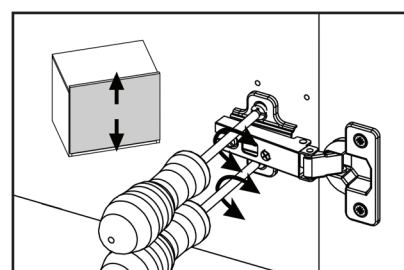
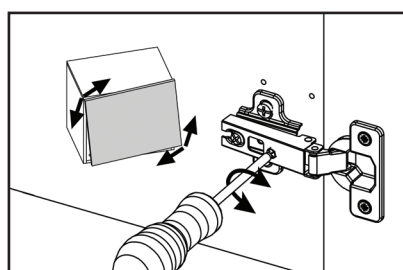
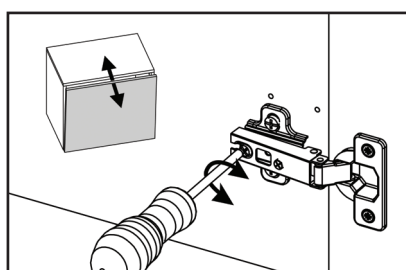

SDP60	
①	1x (720x500mm)
②	1x (720x500mm)
③	1x (567x496mm)
④	1x (567x496mm)
⑤	1x (587x120mm)
⑥	1x (596x110mm)
⑦	1x (599x98mm)
⑧	2x (567x85mm)
⑨	1x (600x600mm)

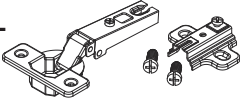

1	<p>A1 </p> <p style="text-align: center;">2x</p>	<p>E1 </p> <p style="text-align: center;">10x</p>
----------	---	--

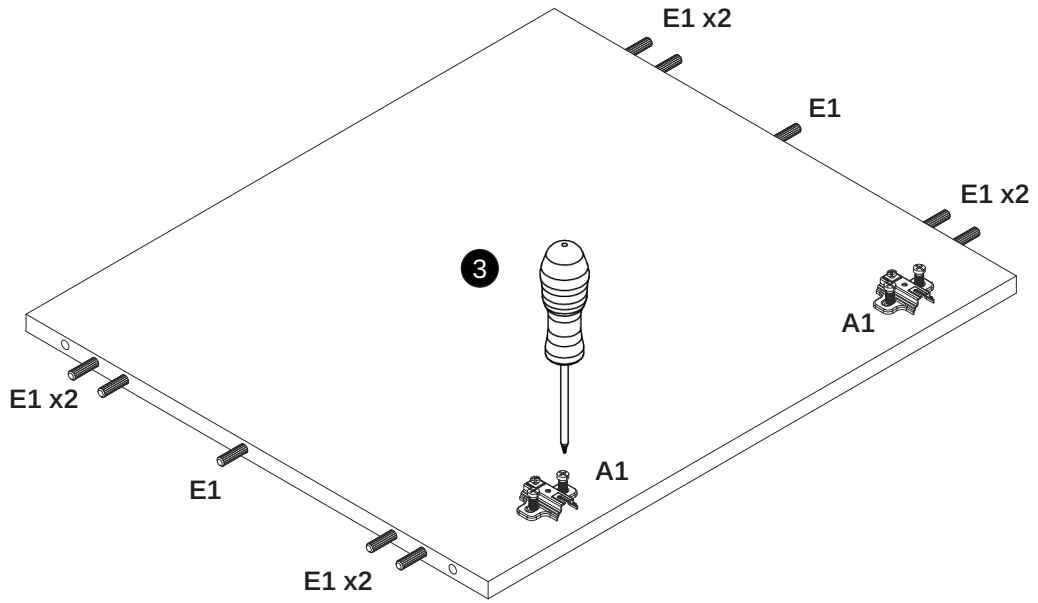

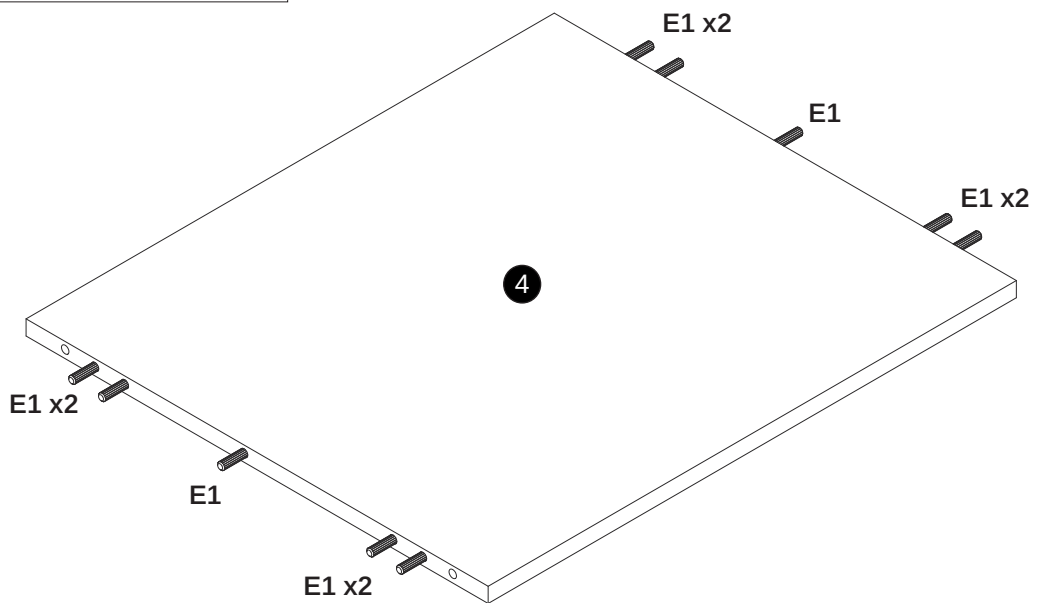

2	<p>E1 </p> <p style="text-align: center;">10x</p>
----------	--

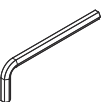

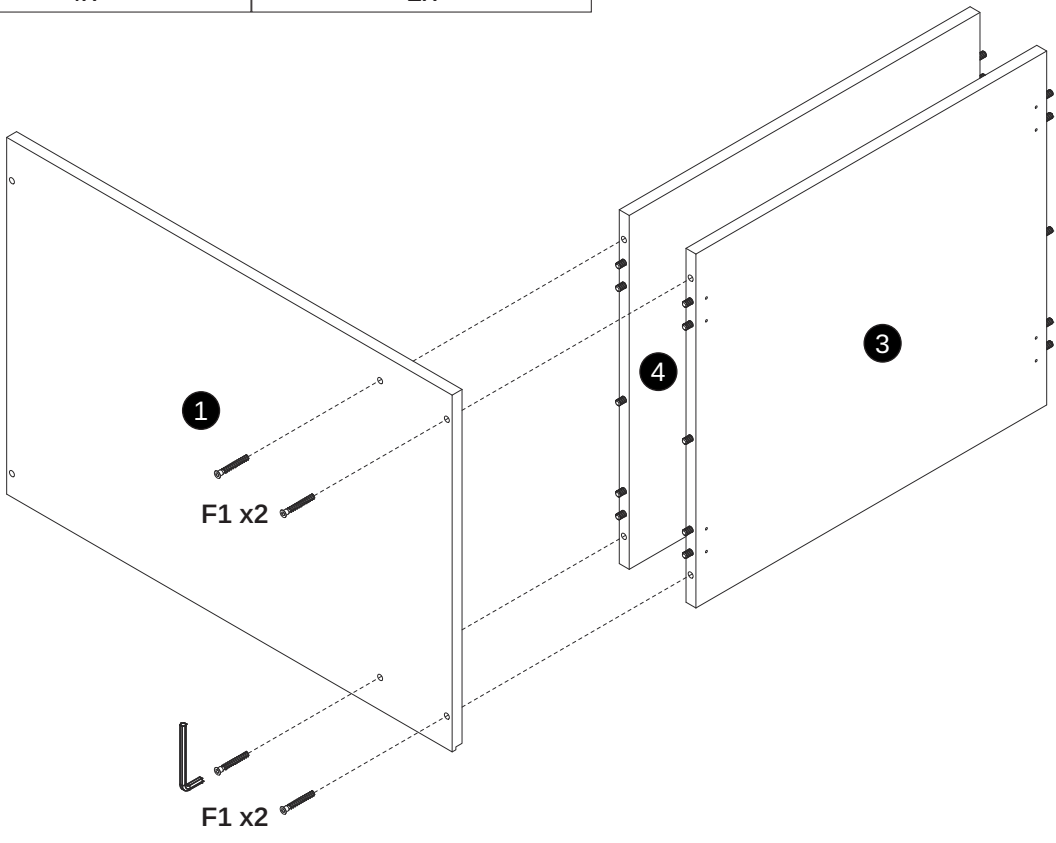
3	F1		K2	
		4x		1x



4

F1		K2	
	4x		1x

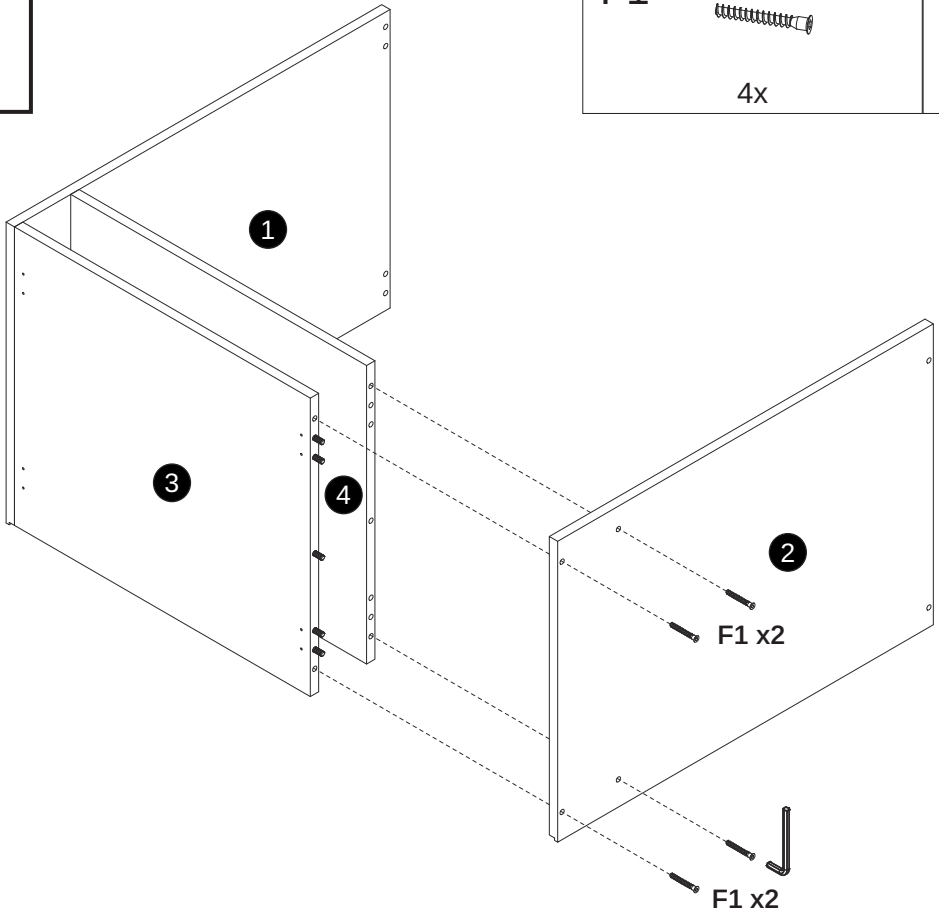

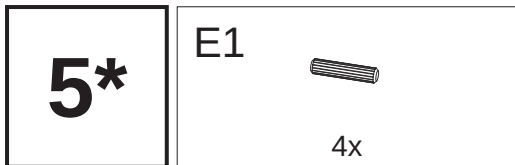

*

Opcjonalnie !
 Optionally !
 Optional !
 En option !

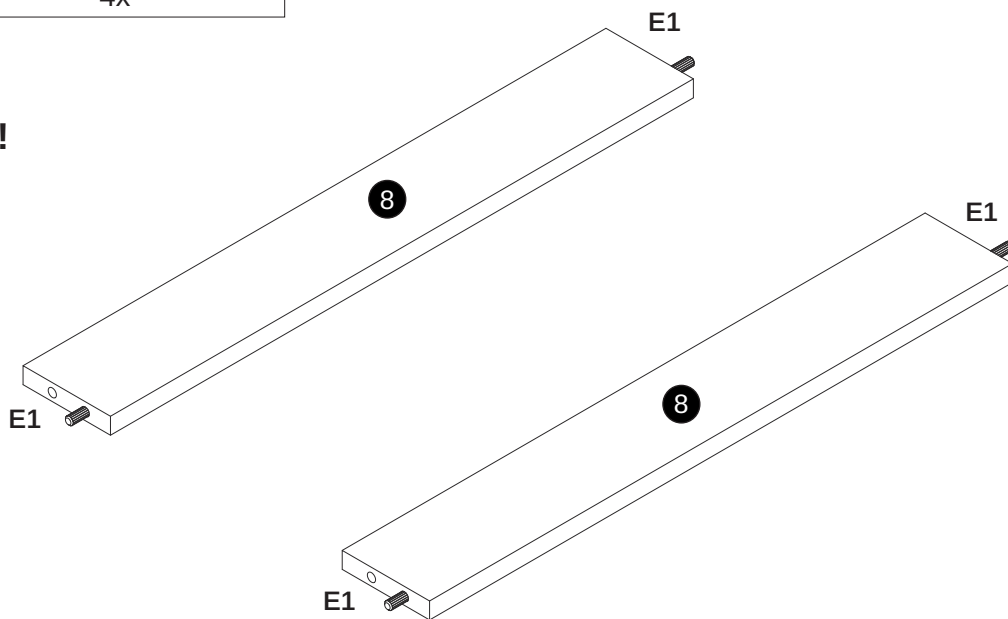

*

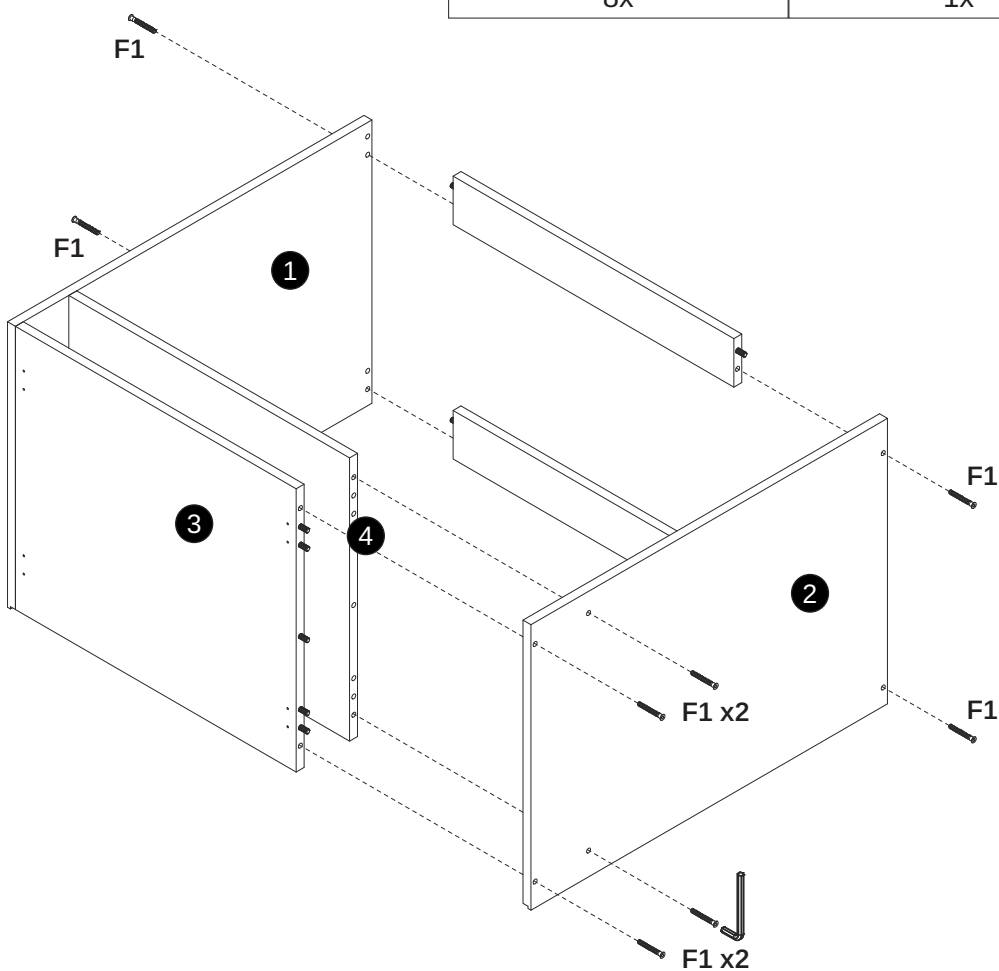
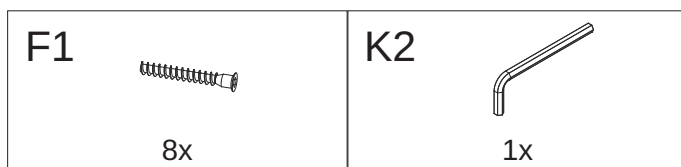

Opcjonalnie !
 Optionally !
 Optional !
 En option !

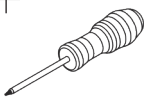

7	S0b	
	8x	

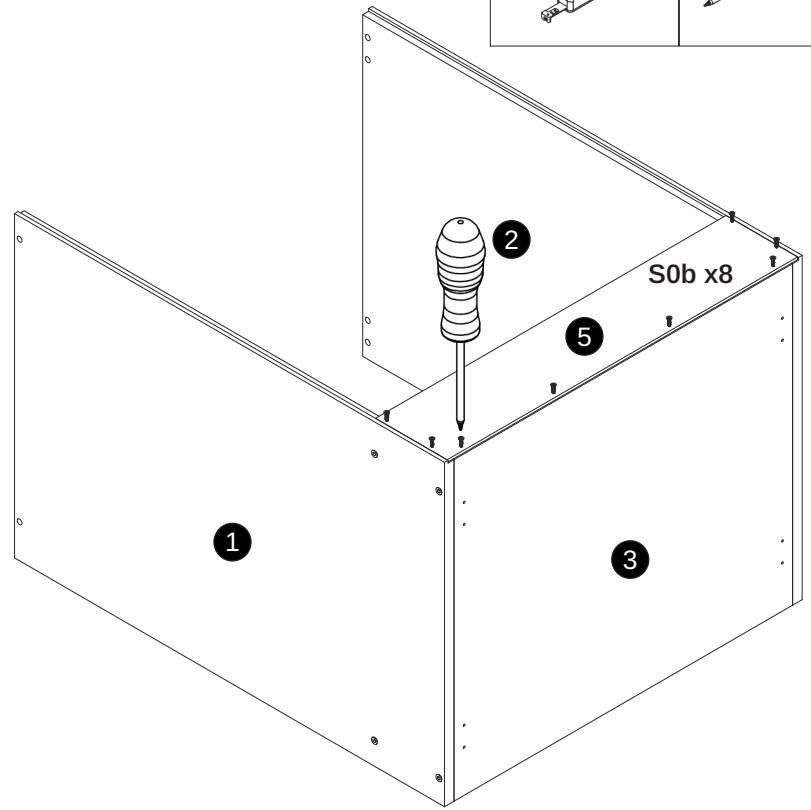
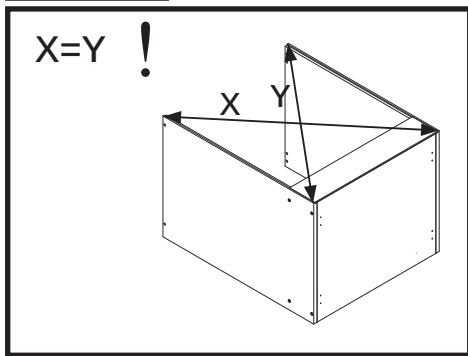
	+	
---	---	---

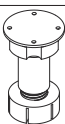

8	U5		S1c	
	4x		16x	

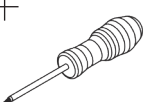
+	
---	---

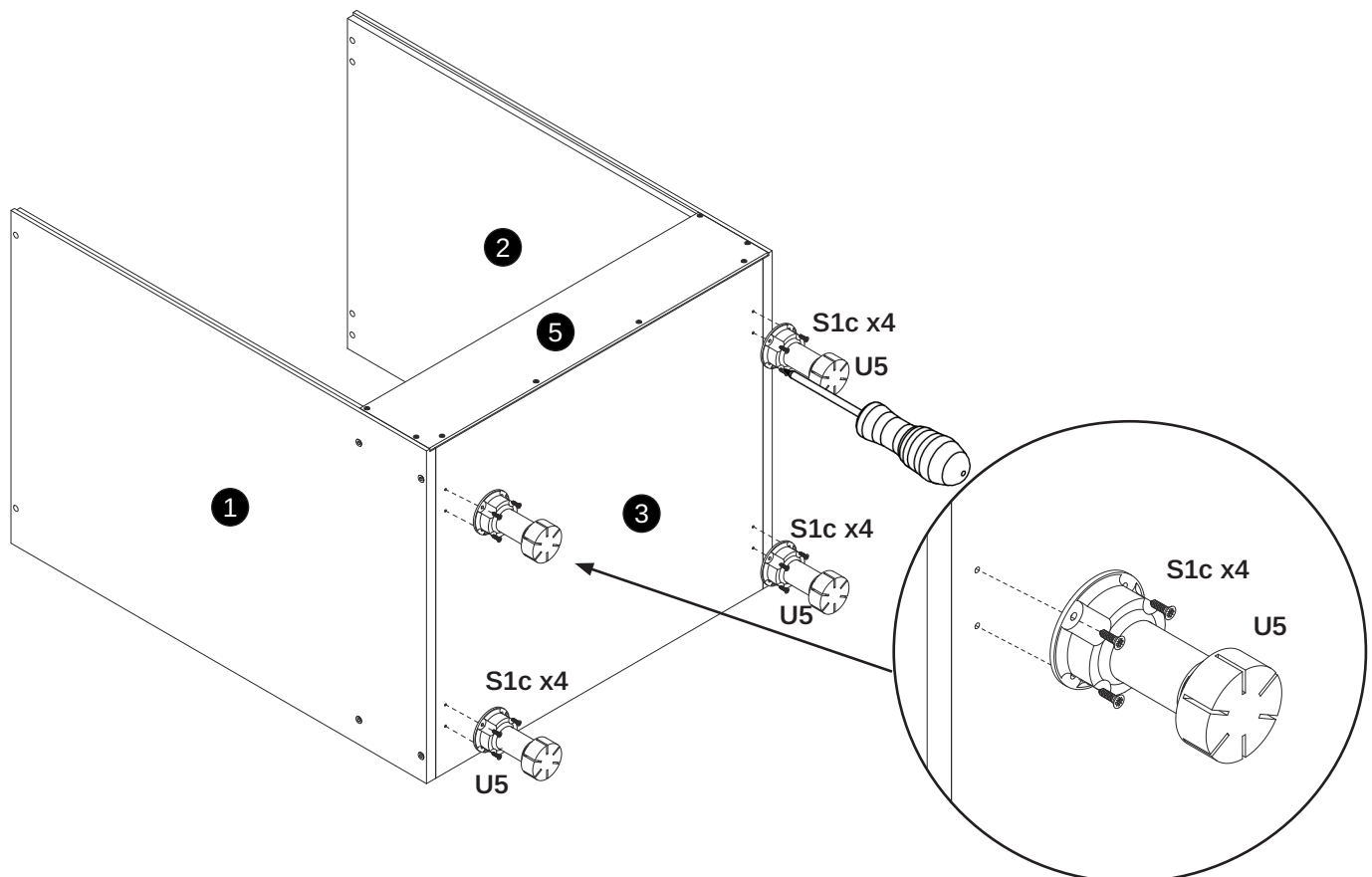

9

! X=Y

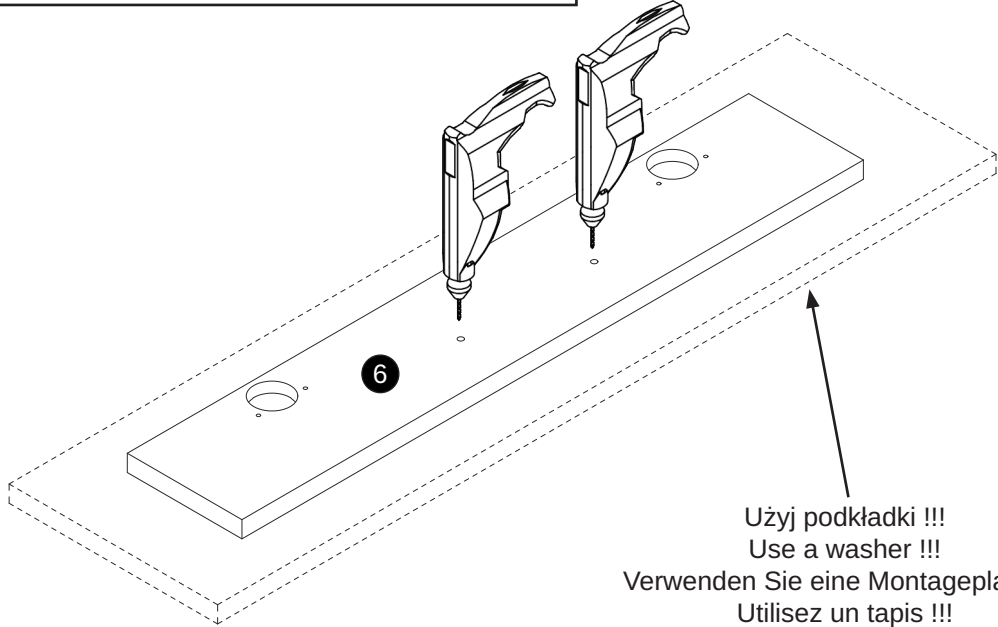
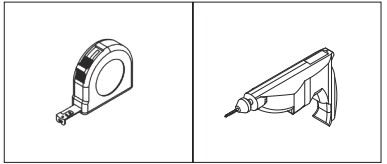
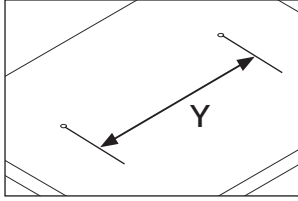
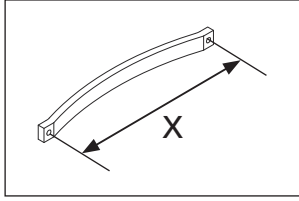

Użyj podkładki !!!
Use a washer !!!
Verwenden Sie eine Montageplatte !!!
Utilisez un tapis !!!

10

U1



1x

P9



2x

A1

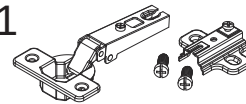

2x

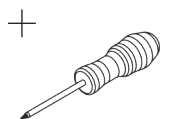

S1c



4x

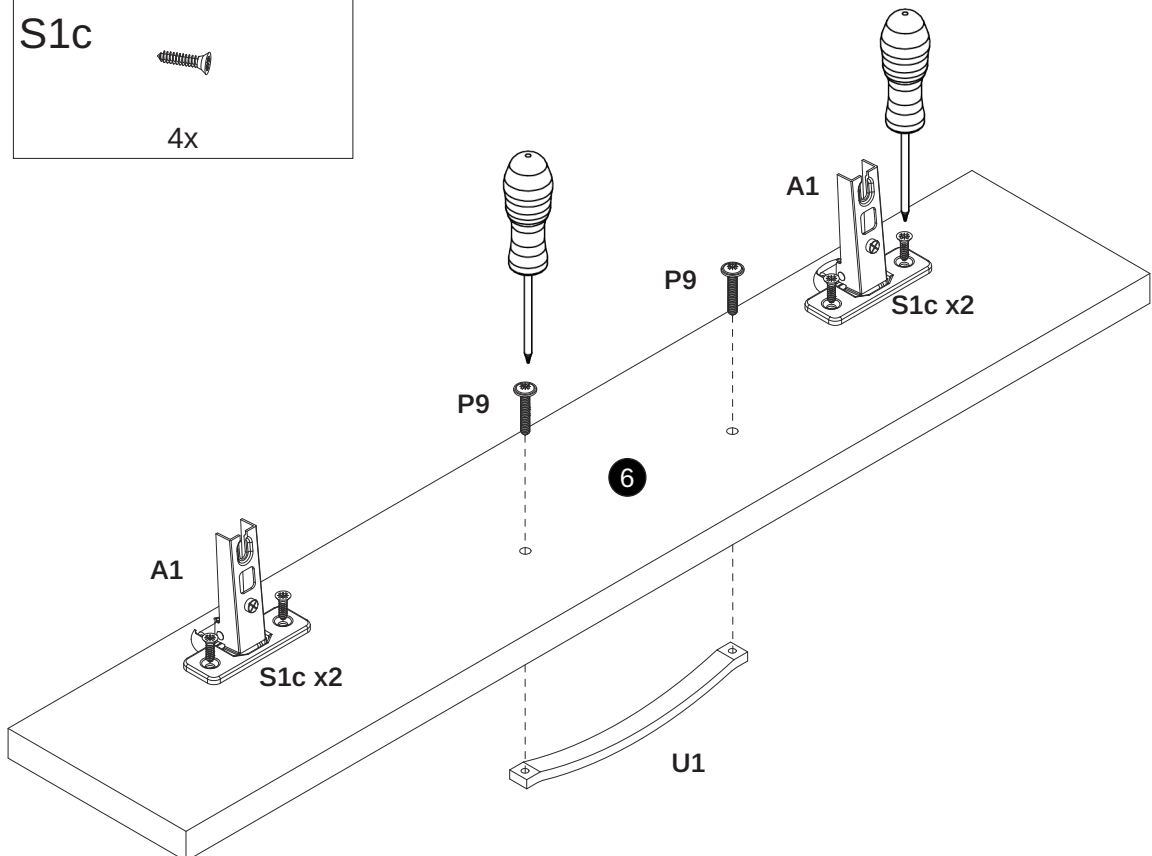

11

F10



x12

D12



x4

+

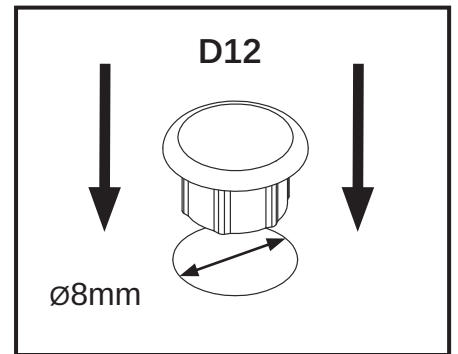
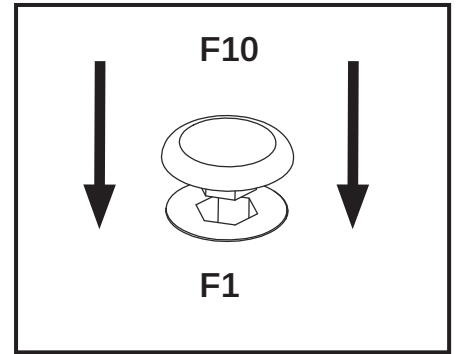
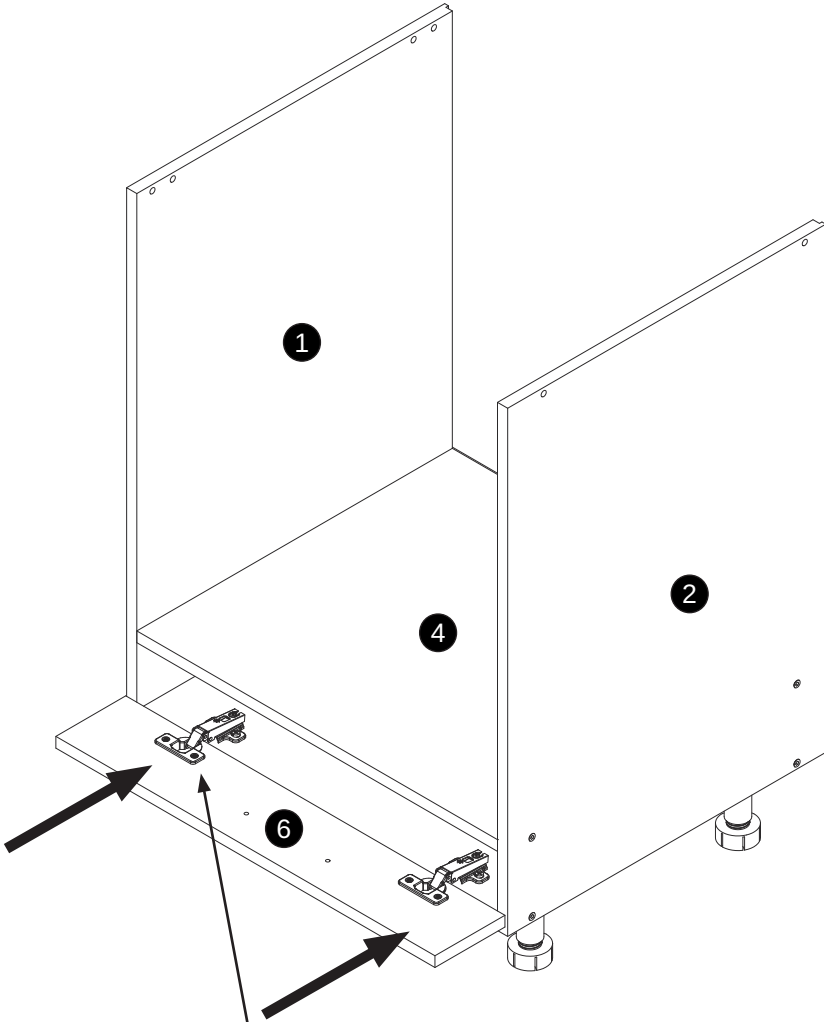

12

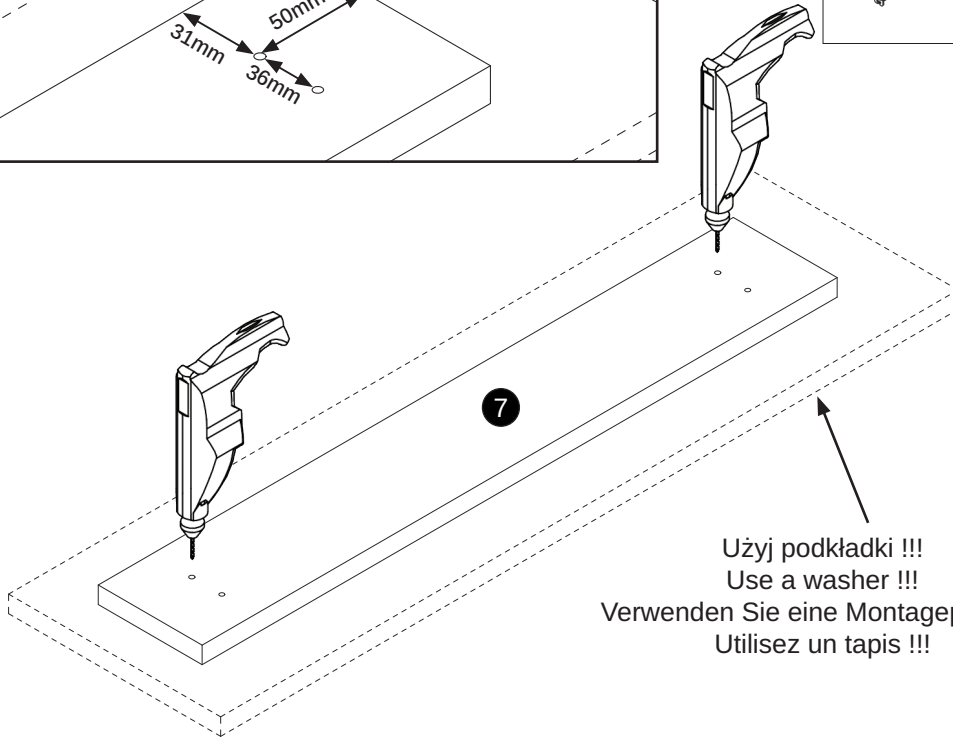
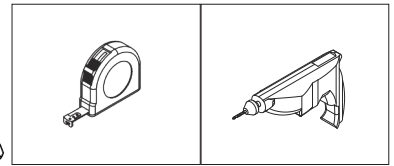
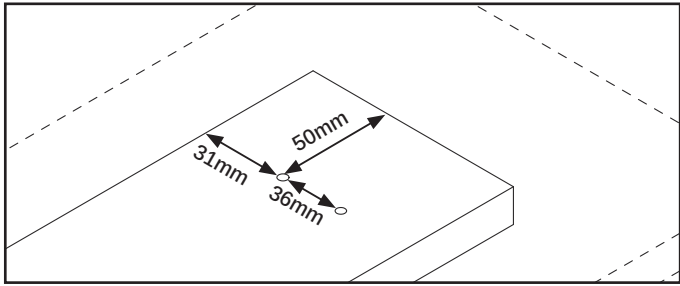

Użyj podkładki !!!
Use a washer !!!
Verwenden Sie eine Montageplatte !!!
Utilisez un tapis !!!

13

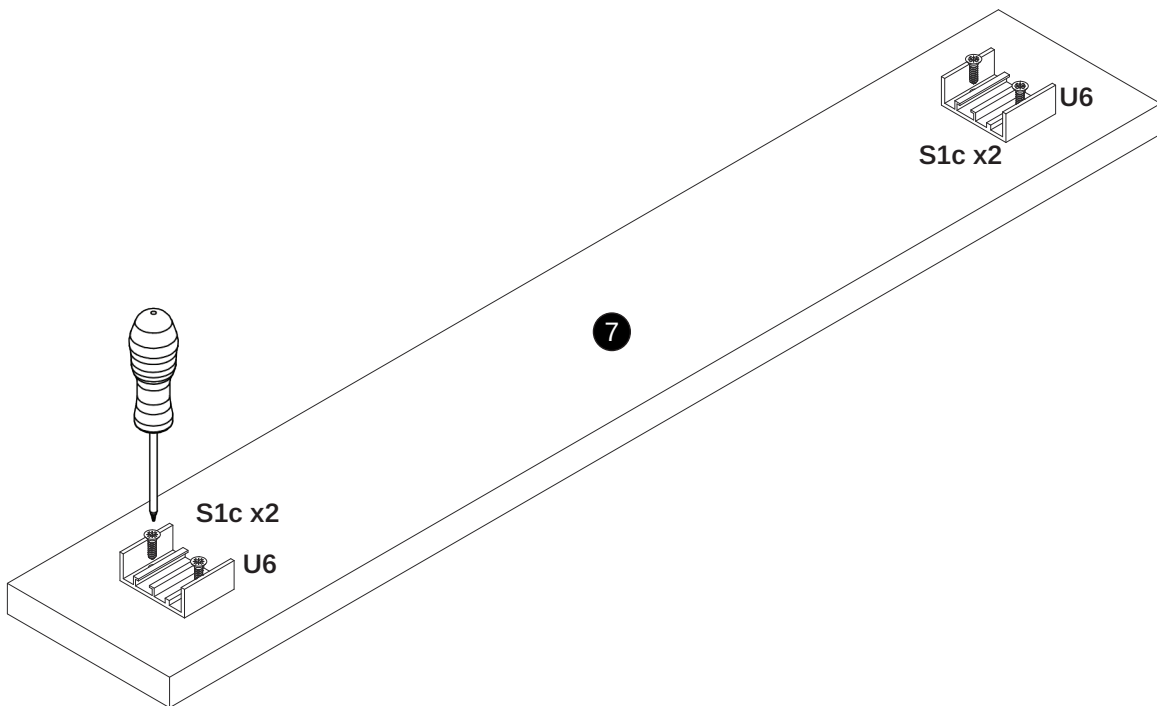
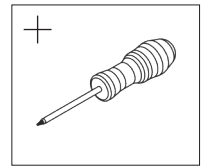
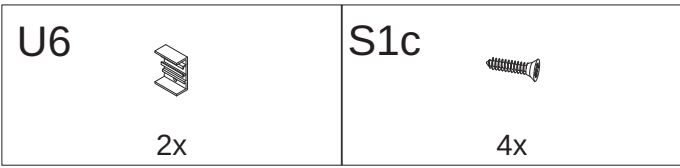

14

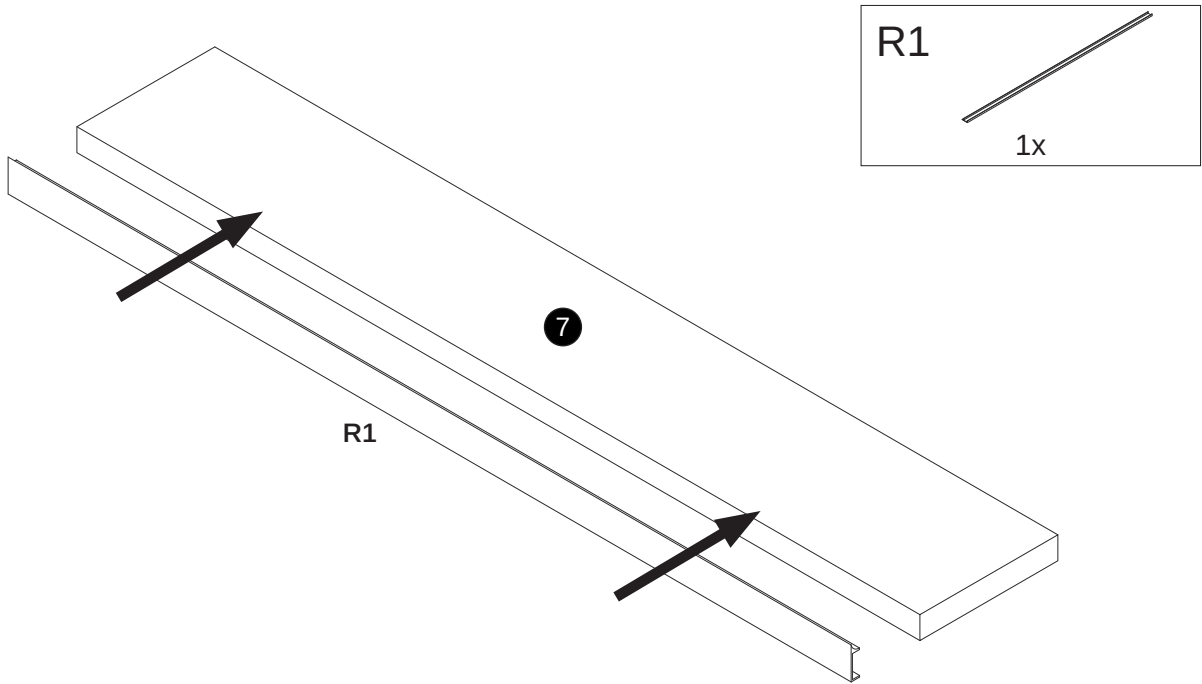

15

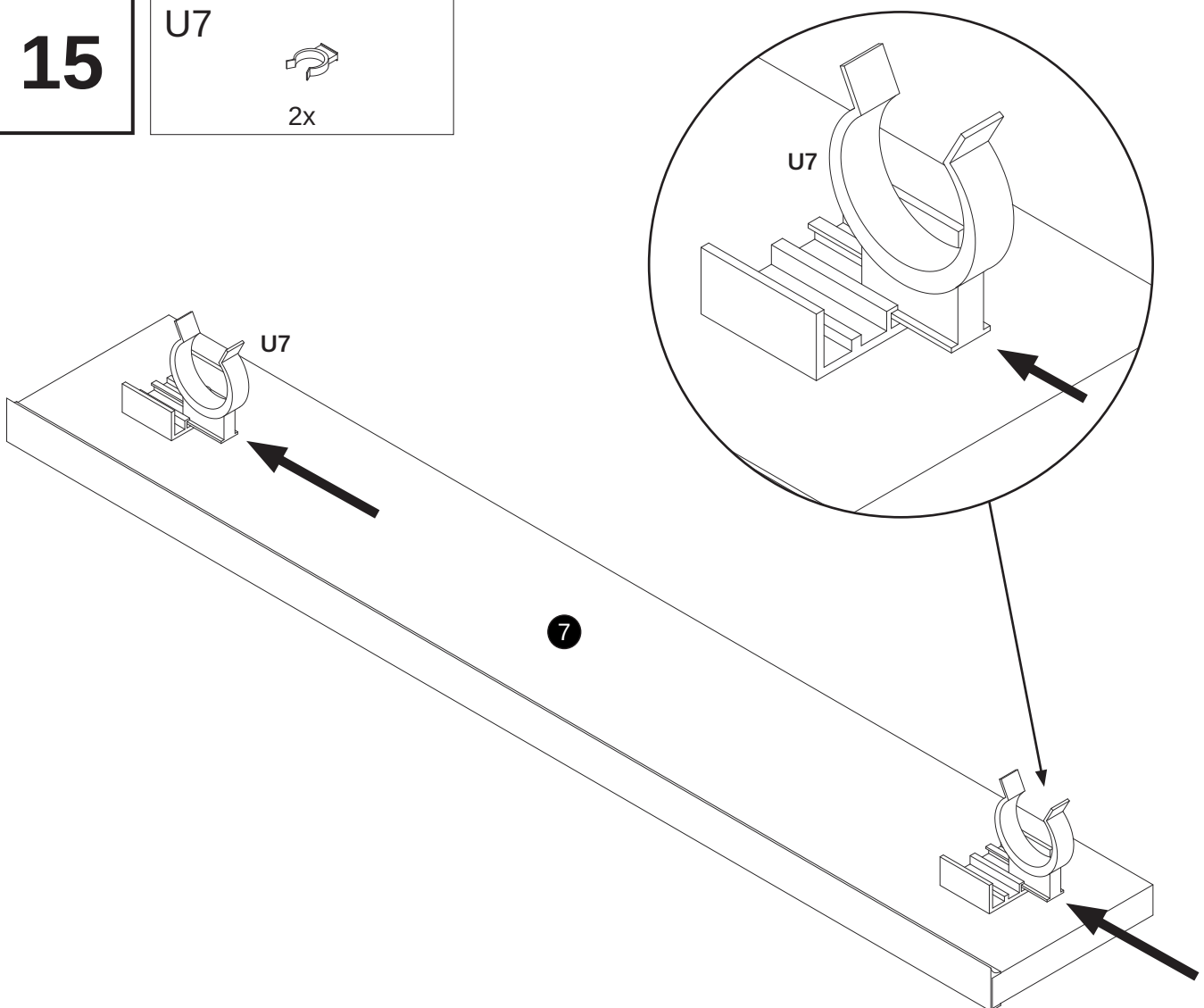
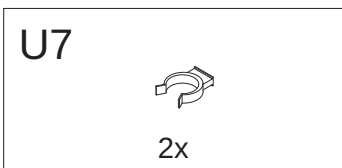

16

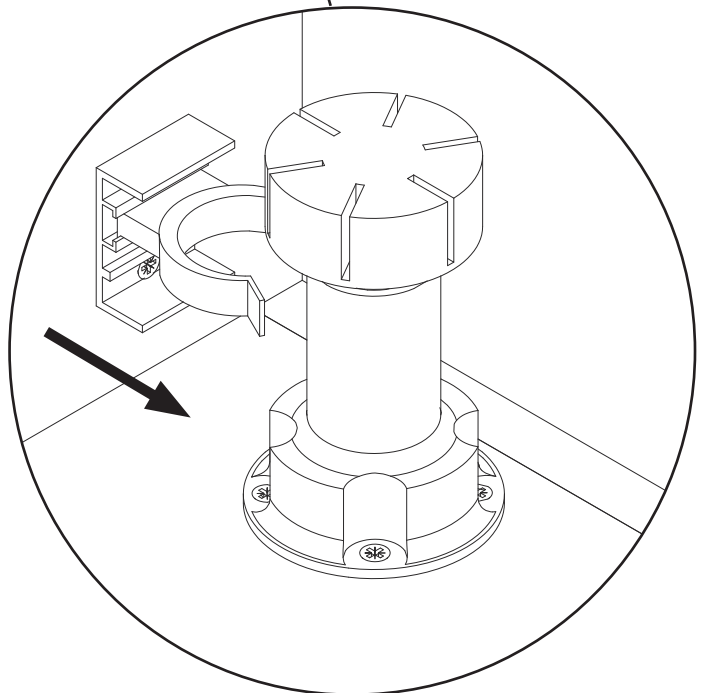
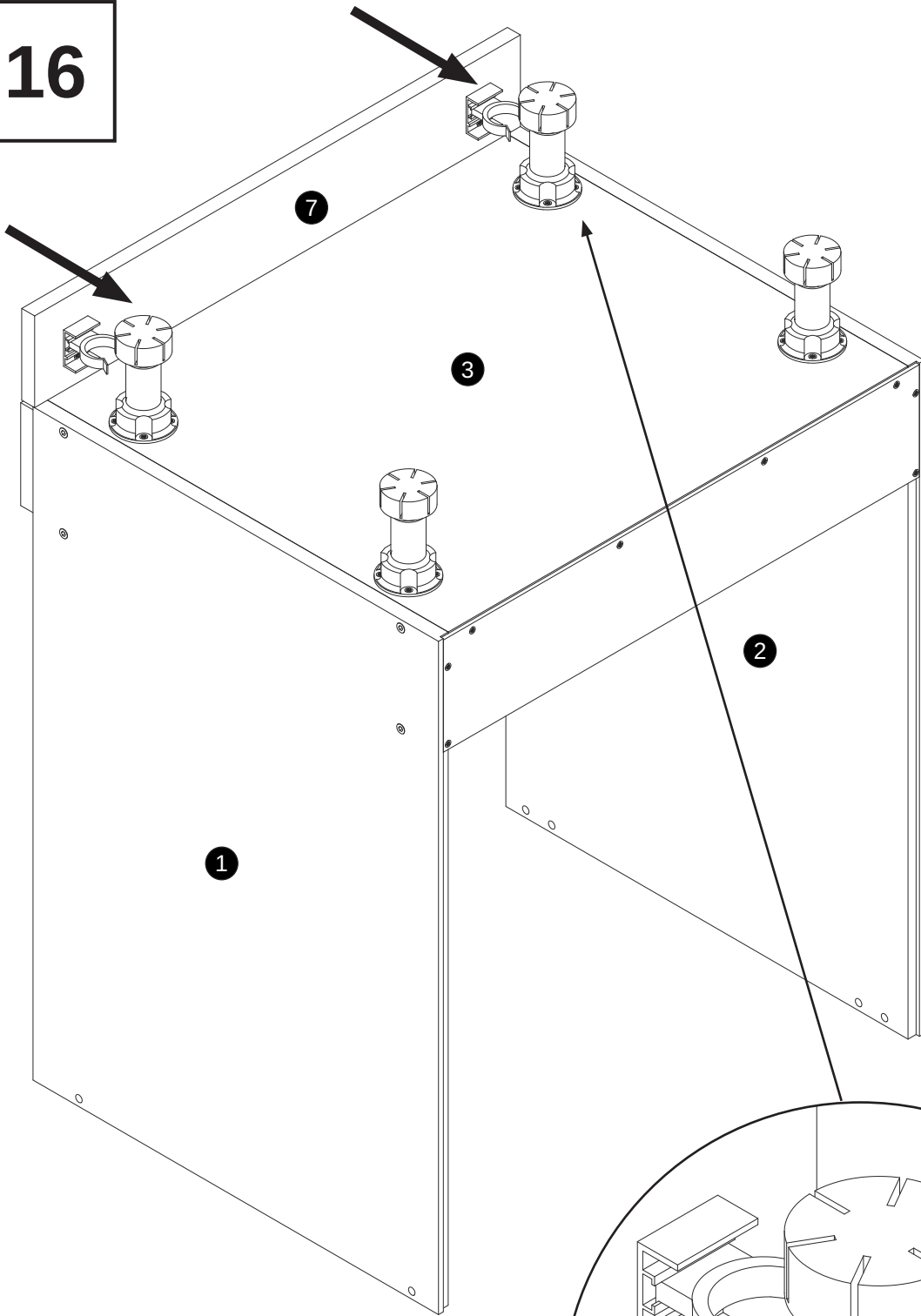

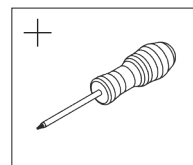

17*	S4b	
		4x

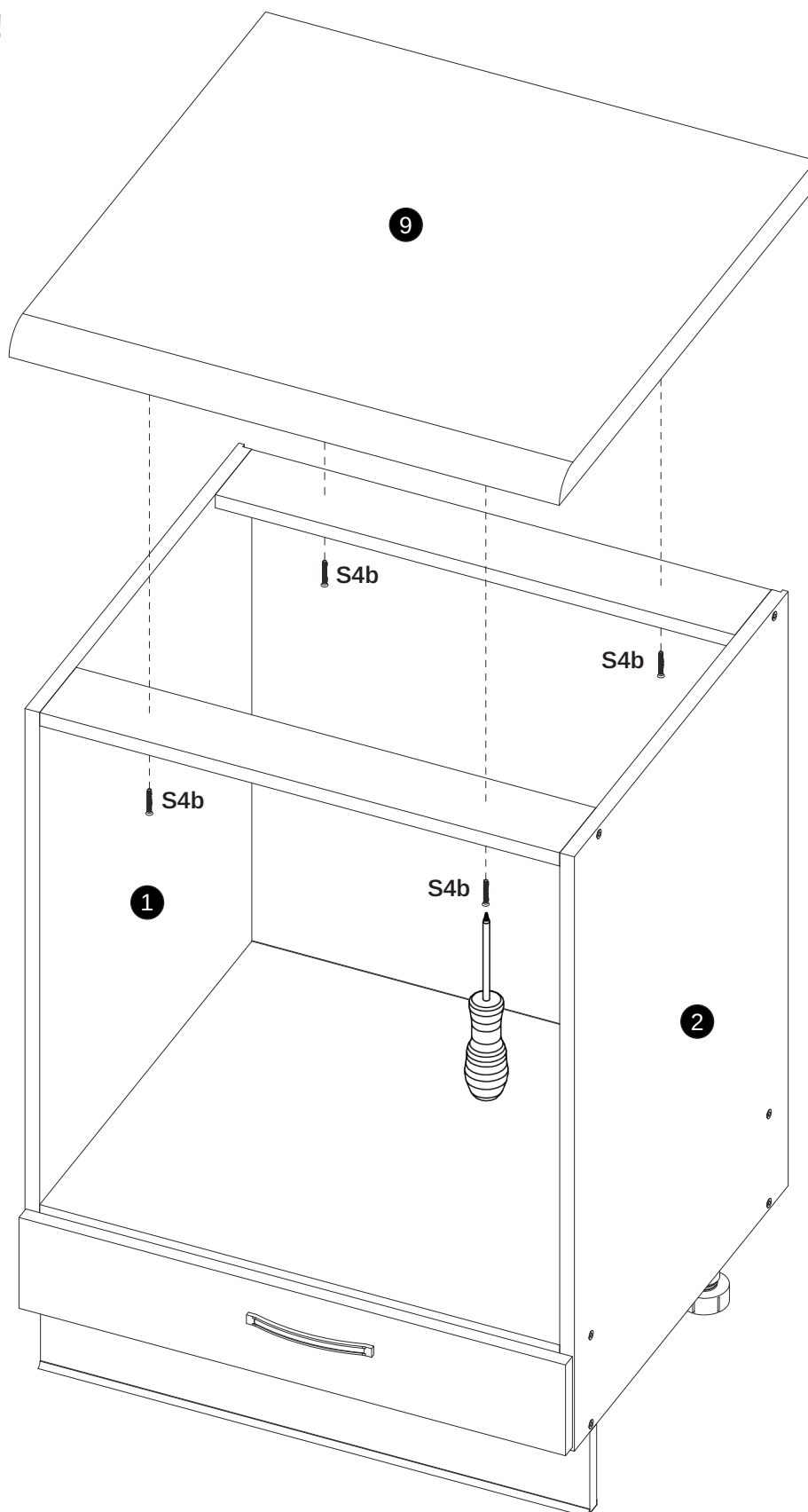

*

Opcjonalnie !
 Optionally !
 Optional !
 En option !



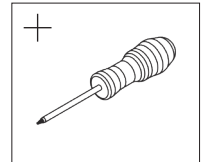

18*	D13		S1c	
		4x		4x

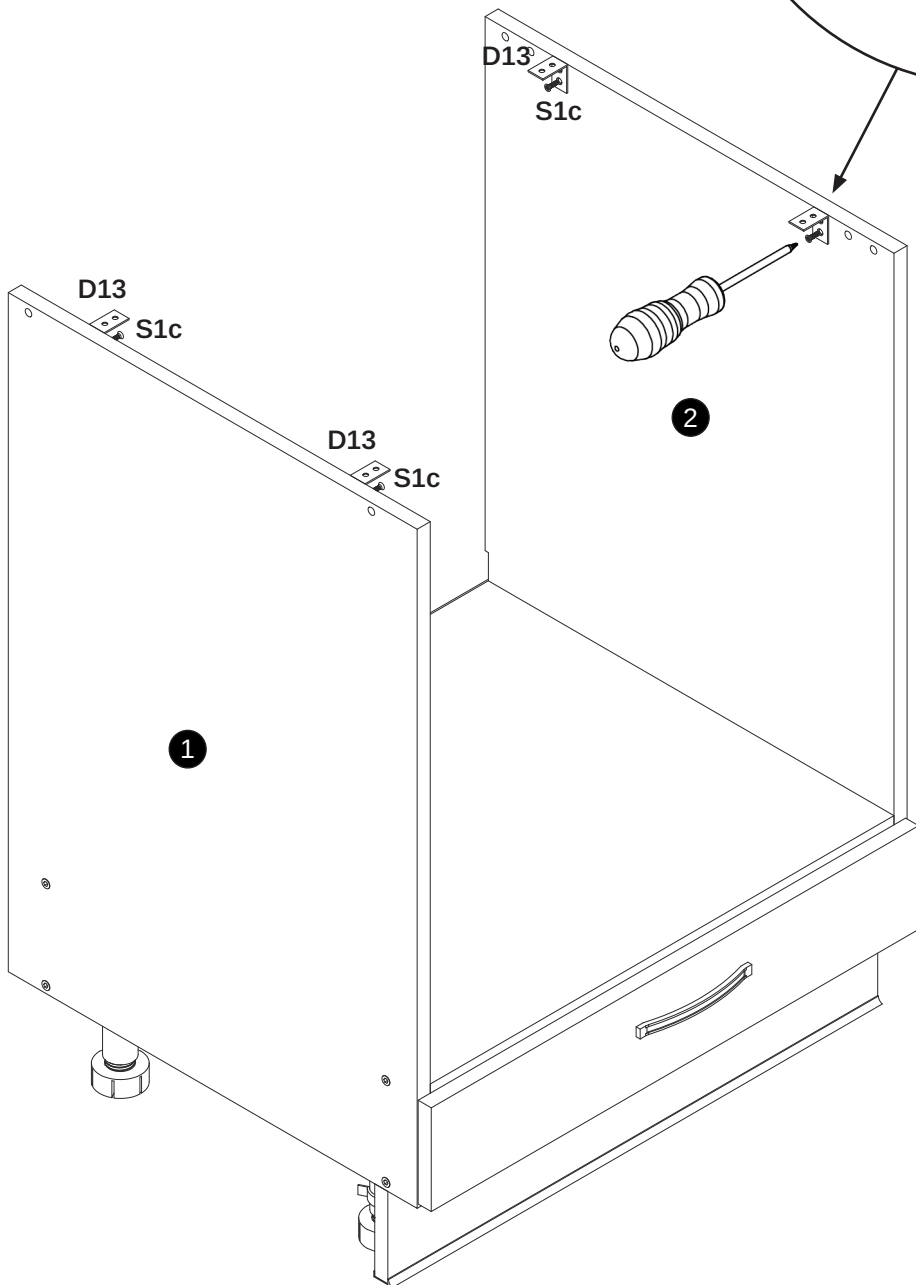
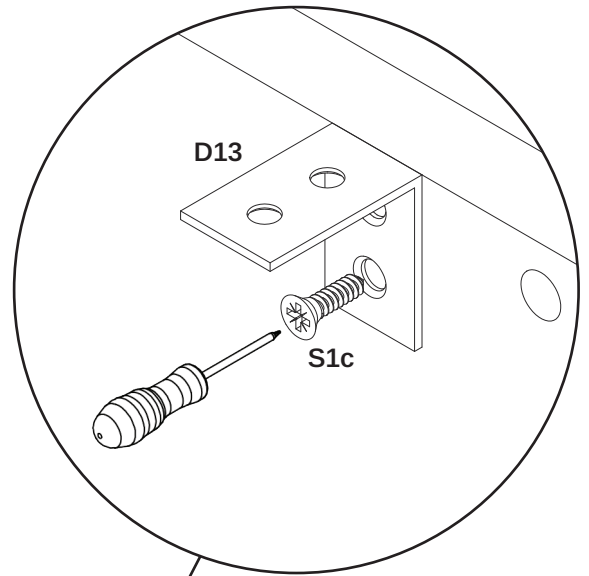

*

Opcjonalnie !
 Optionally !
 Optional !
 En option !



19*	S1c	
	4x	

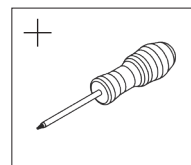

*

Opcjonalnie !
 Optionally !
 Optional !
 En option !

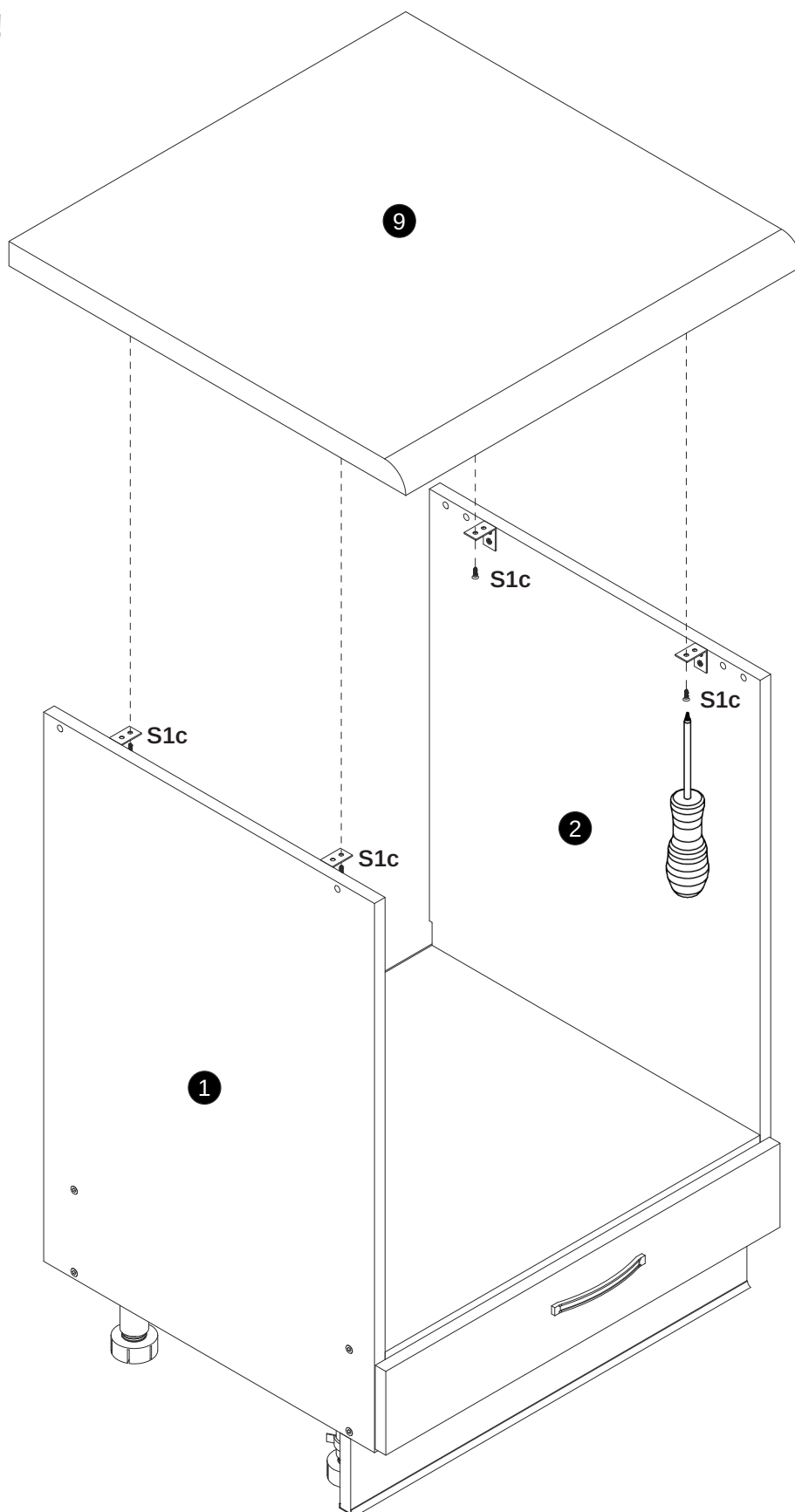

20

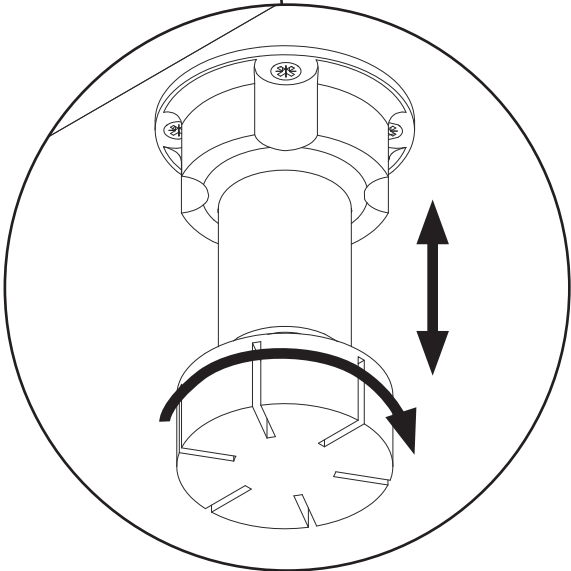
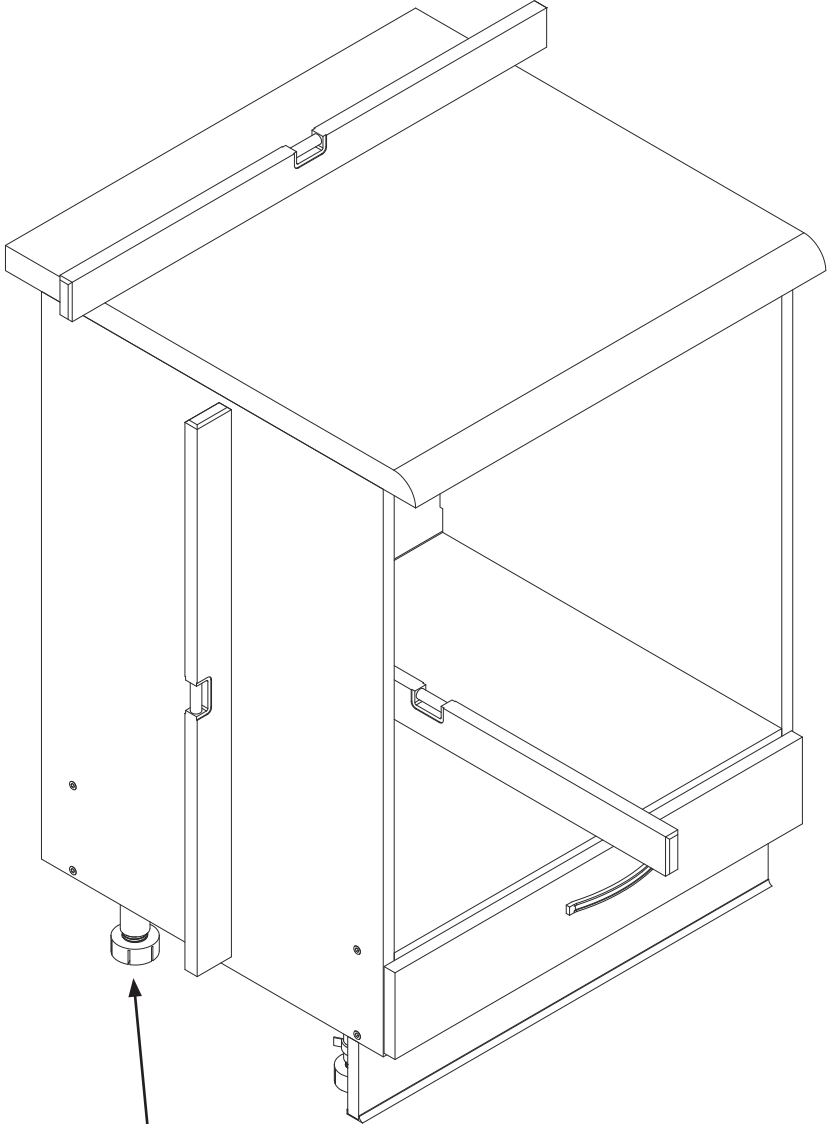
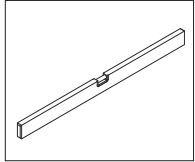

21*

B1 
1x

S1c 
4x

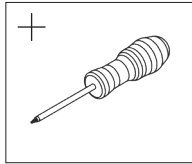

*
Opcjonalnie !
Optionally !
Optional !
En option !

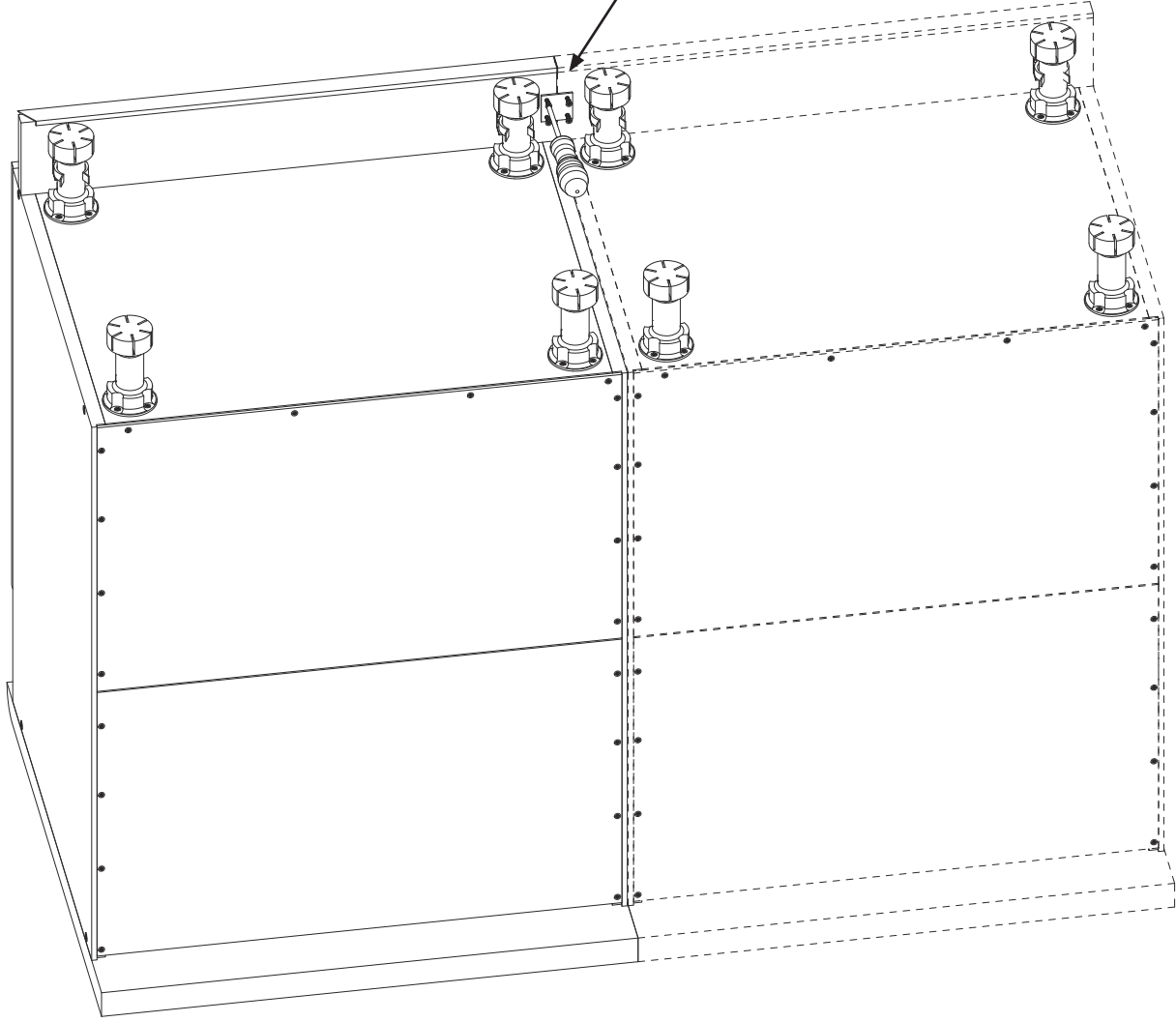
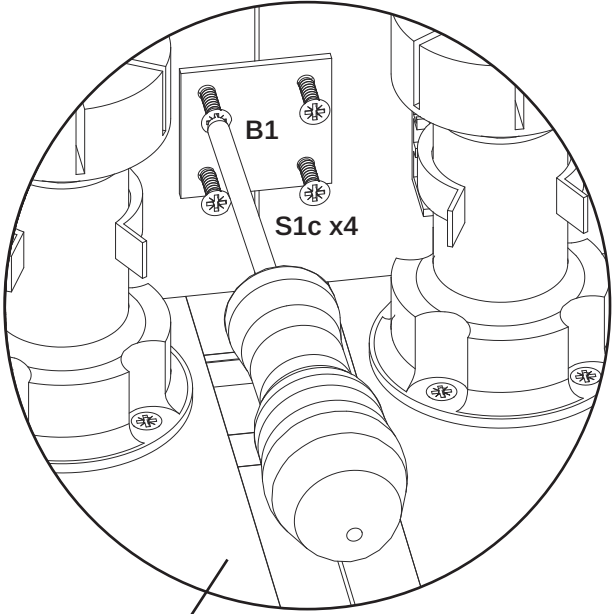

Zasady użytkowania i konserwacji mebli

PL

- Meble należy użytkować w pomieszczeniach suchych, ogrzewanych zabezpieczonych przed szkodliwymi wpływami atmosferycznymi.
- W trakcie użytkowania mebli należy okresowo sprawdzać stan połączeń technicznych takich jak: mimośrodowy, zawiasy, prowadniki.
- Podczas przenoszenia mebli należy chwycić wyłącznie za pionowe elementy konstrukcyjne takie jak boki, nogi. Bezwzględnie nie można chwycić za elementy poziome, takie jak blaty, półki, szuflady, gdyż grozi to poważnymi uszkodzeniami mebli.
- Powierzchnię mebli należy czyścić wyłącznie środkami przeznaczonymi do pielęgnacji mebli.

EN

- Furniture should be kept in dry places which are heated and protected by harmful influence of atmospheric conditions.
- While the furniture is in use there is a necessity to periodically check the state of the technical connections such as: eccentric rods, hinges, guides.
- While furniture is carried it is necessary to keep only the vertical components, such as sides and legs of the furniture.
- The surface of the furniture should be cleaned only with detergents for furniture care.

DE

- Die Möbel soll man in den trockenen, beheizten und vor den schädlichen Witterungseinflüssen gesicherten Räumen benutzen.
- Im Laufe der Benutzung der Möbel soll man zeitlich den Zustand der technischen Verbindungen wie: Exzenter, Türbänder und Leitstücke prüfen.
- Während des Möbeltransports muss man ausschließlich nach vertikalen Konstruktionselementen wie: Ecken und Beine greifen. Auf keinen Fall darf man nach horizontalen Elementen, wie Blätter, Bretter und Schubladen greifen, was zur ernsthaften Möbelbeschädigung bringen kann.
- Die Fläche der Möbel soll man nur mit dazu geeigneten Pflegemöbelmitteln putzen.

FR

- Les meubles doivent être utilisés dans des pièces sèches, chauffées et protégées contre les effets nocifs de la pollution. Les meubles doivent être utilisés dans des locaux secs, chauffés et protégés des influences atmosphériques nocives.
- Lors de l'utilisation du mobilier, l'état des connexions techniques telles que: excentriques, charnières, guides.
- Lorsque vous déplacez le meuble, ne manipulez que les éléments structurels verticaux, tels que les côtés, jambes. Vous ne devez absolument pas saisir les éléments horizontaux tels que les plateaux, les étagères, les tiroirs, car cela peut provoquer des dommages importants au mobilier.
- La surface du meuble doit être nettoyée uniquement avec des produits destinés à l'entretien des meubles.



Szafka SDSZ60/2 ver.1 (85,2x60x60)

Szafka SDSZ60/2 ver.2 (85,2x60x60) with a soft close

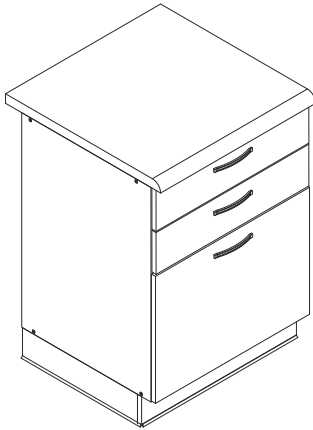

Ilość potrzebnych osób
Number of people needed
Benötigte Personenzahl
Nombre de personnes nécessaires

Niezbędne narzędzia do montażu

Tools necessary for assembly

Notwendiges Werkzeug für die Montage

Outils nécessaires pour le montage

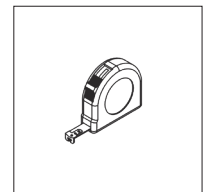
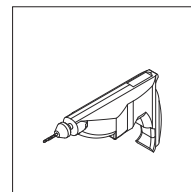
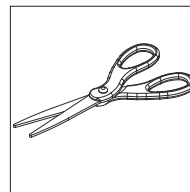
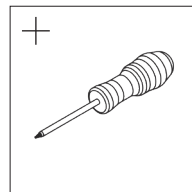

PL

- Przed przystąpieniem do montażu przeczytaj i zapoznaj się z całą instrukcją.
- Przestrzegaj bezwzględnie kolejnych kroków montażowych **1**, **2**, **3**...
- Nie wyrzucaj opakowania dopóki nie ukończysz skutecznie w całości montażu.
- Montaż wykonuj na płaskiej, miękkiej oraz czystej powierzchni takiej jak tektura.
- Bezwzględnie nie montuj elementów jeśli zauważysz ich wady lub uszkodzenia.
- Elementy montażowe takie jak okucia trzymaj w miejscu niedostępnym dla niemowląt i dzieci.
- Wadliwe lub uszkodzone elementy reklamuj podając ich numer z instrukcji montażu.
- Jeśli uszkodzony element będzie zamontowany reklamacja nie będzie uznana.

EN

- Read and get familiar with the whole instruction before the process of installation.
- Imperatively observe the consecutive assembly steps **1**, **2**, **3**...
- Do not throw away the packaging until the installation is successfully done.
- The installation should be done on the flat, soft and clear surface, such as cardboard.
- Under no circumstances should you install the elements in case of any faults or damage.
- The installation elements as fittings should be kept in a place unavailable for babies or children.
- Faulty or damaged components should be complaint by giving the number of the assembly instruction.
- If the damaged component is installed, the complaint will not be accepted.

DE

- Vor Beginn der Montage muss man die Instruktion genau durchlesen.
- Die aufeinanderfolgenden Montageschritte **1**, **2**, **3**... unbedingt beachten.
- Man muss die Packung behalten bis man die ganze Montage erfolgreich nicht beendet.
- Die Montage muss man auf einer glatten, weichen und sauberen Fläche ausüben
- Fehlerhafte oder beschädigte Elemente darf man auf keinen Fall montieren. Auf keinen Fall darf man fehlerhafte oder beschädigte Elemente montieren.
- Die Montageelemente wie Beschläge muss man unzugänglich von Babys und Kindern halten.
- Fehlerhafte oder beschädigte Elemente muss man nur mit Nummer der Instruktion reklamieren.
- Falls das beschädigte Element montiert wird, wird die Reklamation nicht berücksichtigt.

FR

- Avant de commencer le montage, lire et prendre connaissance de l'intégralité du manuel.
- Respectez scrupuleusement les étapes d'installation suivantes **1**, **2**, **3**...
- Ne pas jeter l'emballage avant d'avoir terminé l'assemblage.
- Le montage doit être effectué sur une surface plane, souple et propre, comme du carton.
- Ne pas assembler si vous remarquez des défauts ou des dommages.
- Garder les éléments de montage tels que les raccords hors de portée des bébés et des enfants.
- Réclamer les pièces défectueuses ou endommagées en citant le numéro figurant dans les instructions de montage.
- Si l'article endommagé est installé, la plainte ne sera pas acceptée.

SZAFKA SDSZ60/2

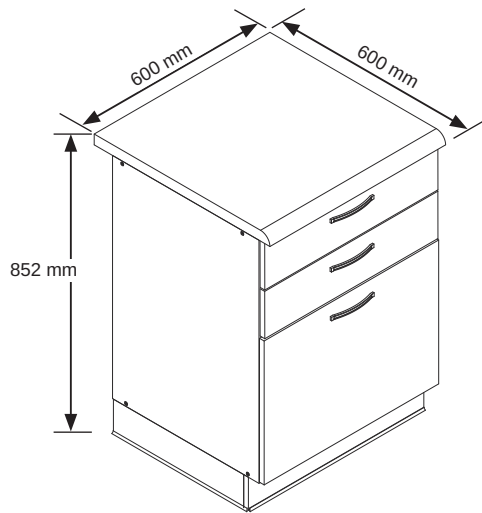

F10



x8

B1

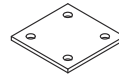

x1

J2

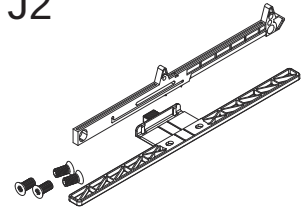

ver.1 - x0 | ver.2 - x4

Okucia / Fittings / Beschläge / Embouts

E1

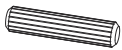

x14

U1



x3

F1



7x50mm

x8

P9



4x27mm

x6

A1

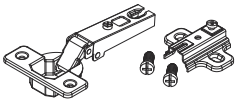

x2

K2

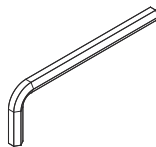

x1

J1

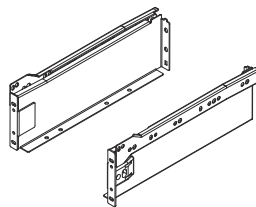

x2

U5

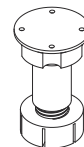

x4

H1

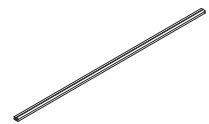

x1

S0b



3x16mm

x20

D11



x2

R1

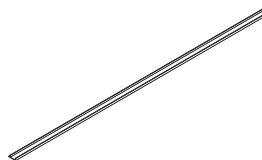

x2

S1c



3,5x16mm

x32

S0a



3x13mm

x4

S3a



4x13mm

x12

S1a



3,5x13mm

x24

S4b



4x30mm

x4

U6



x4

U7



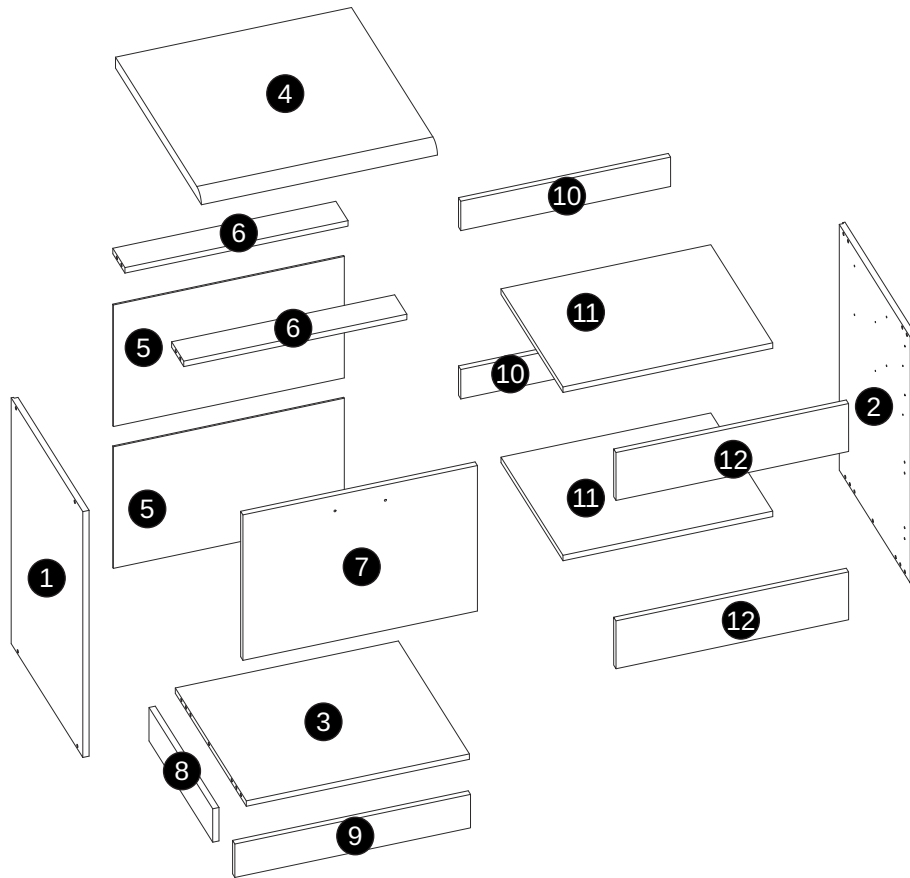

x4



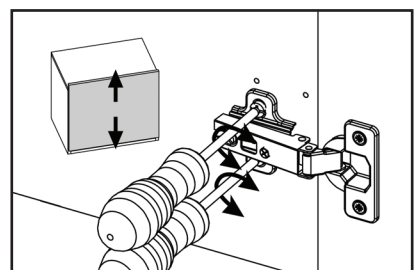
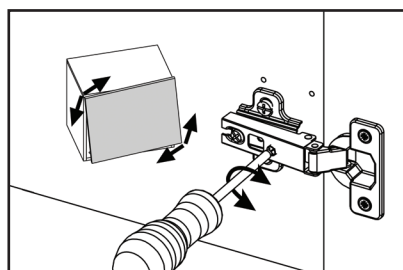
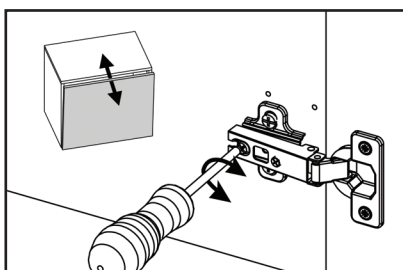

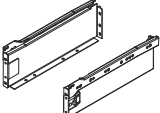

SDSZ60/2	
①	1x (720x500mm)
②	1x (720x500mm)
③	1x (567x496mm)
④	1x (600x600mm)
⑤	2x (587x356mm)
⑥	2x (567x85mm)
⑦	1x (596x425mm)
⑧	1x (445x98mm)
⑨	1x (599x98mm)
⑩	2x (538x86mm)
⑪	2x (538x432mm)
⑫	2x (596x140mm)

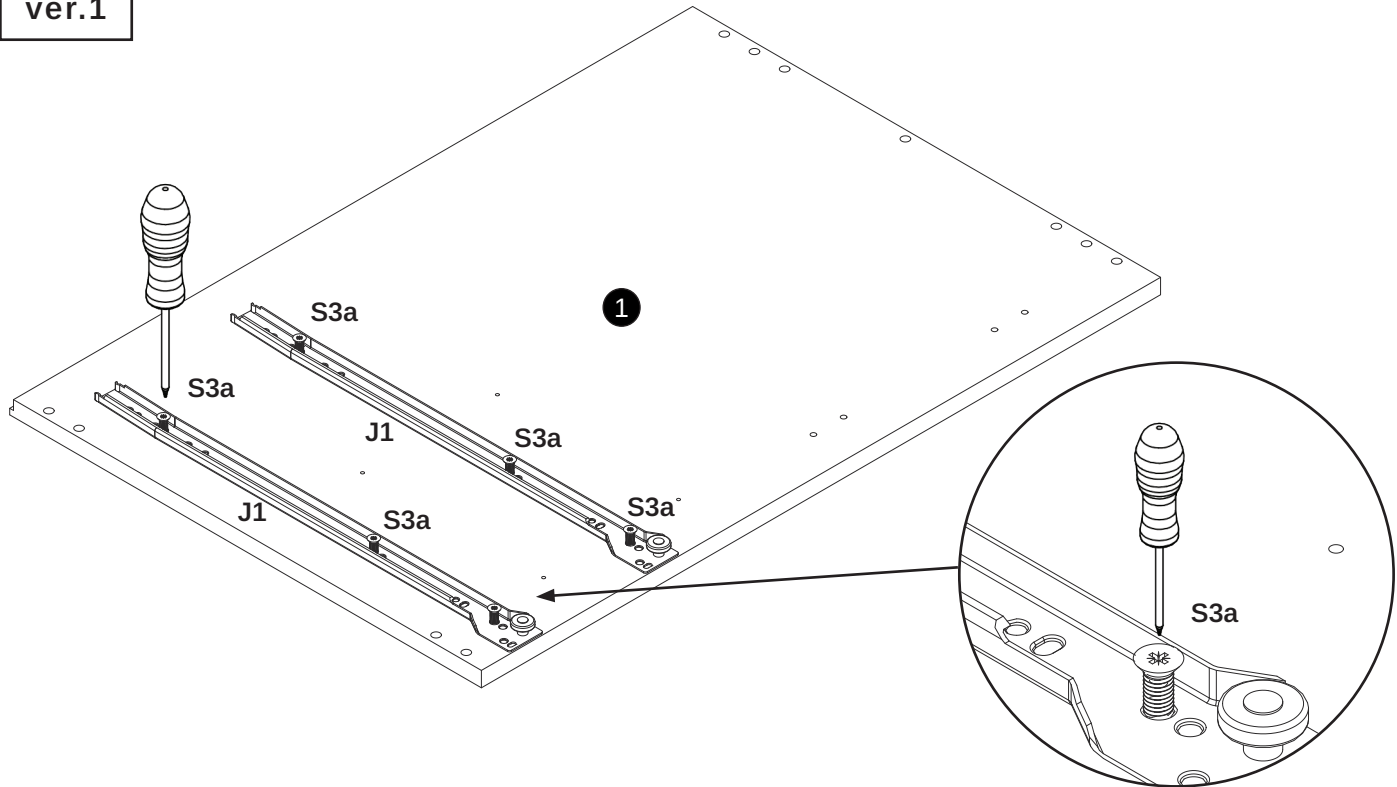

1	J1  2x	S3a  6x	
----------	--	---	---

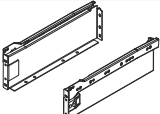
ver.1

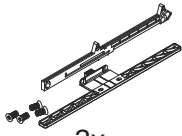

1	J1  2x	S3a  6x	J2  2x	
----------	--	---	--	---

ver.2

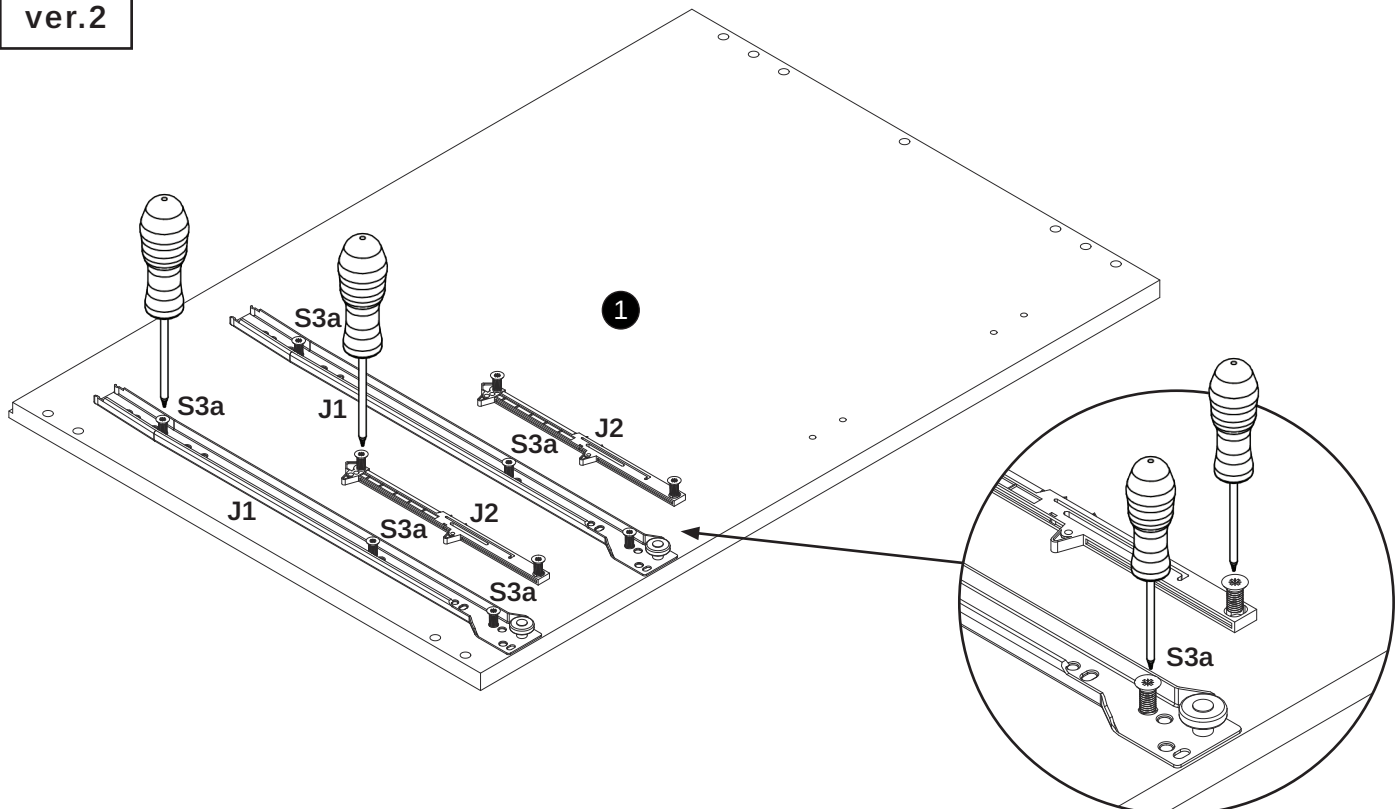

2

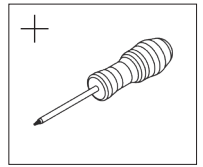
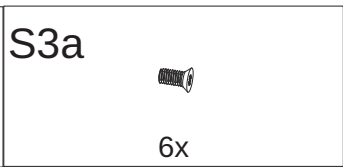
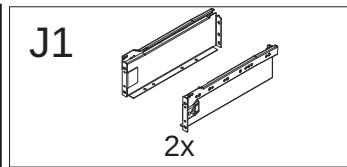

ver.1

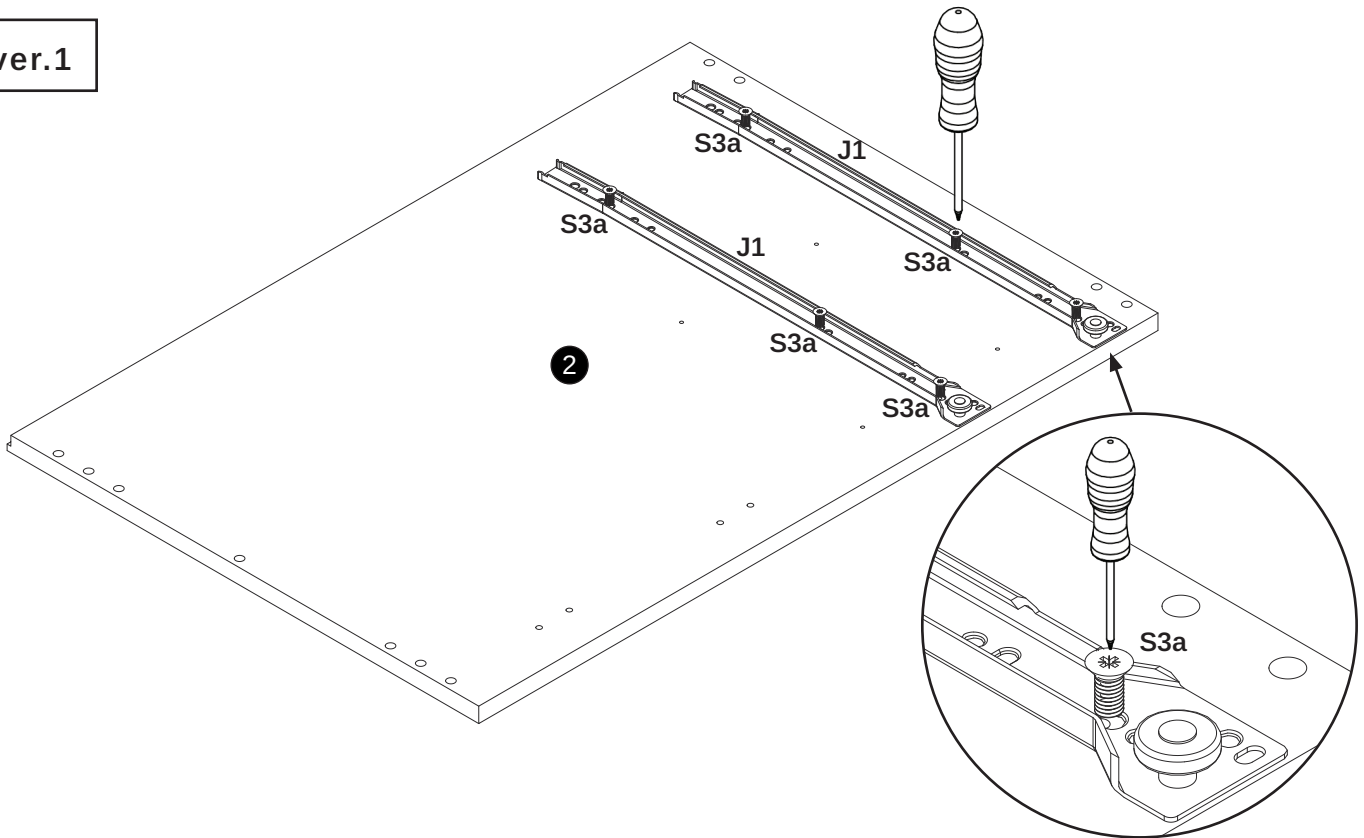

2

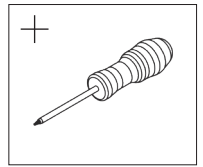
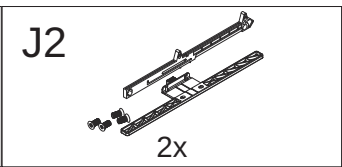
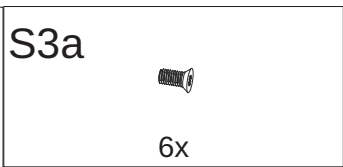
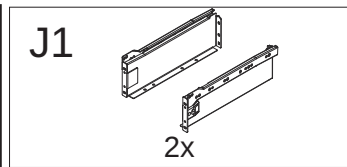

ver.2

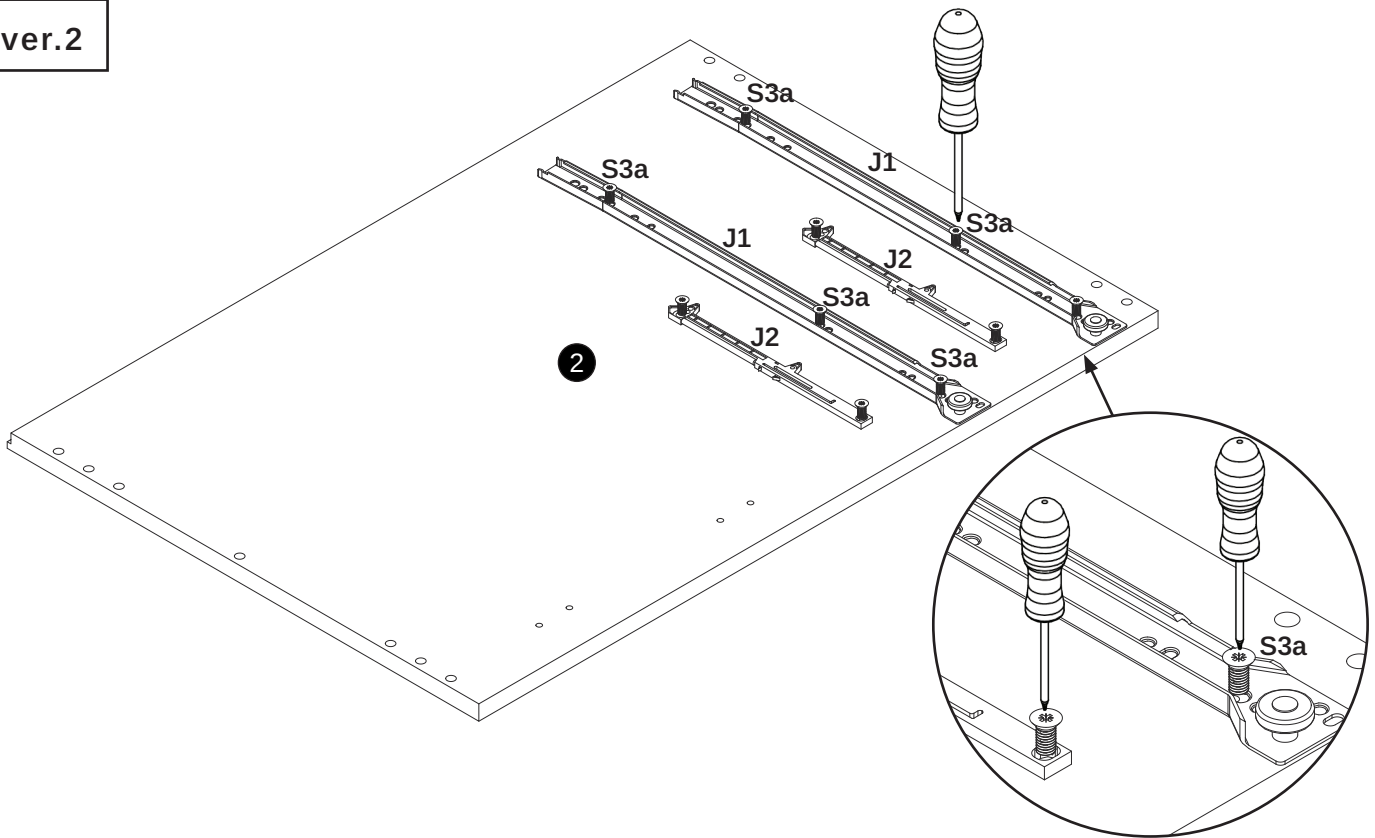

3	E1	
		4x

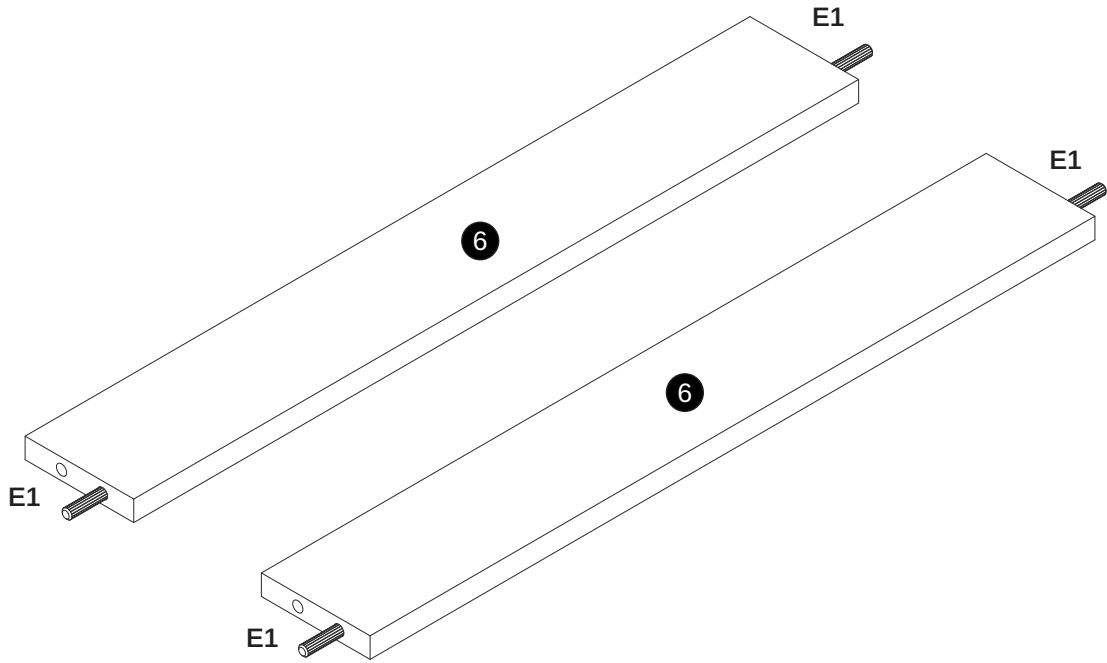

4	E1	
		10x

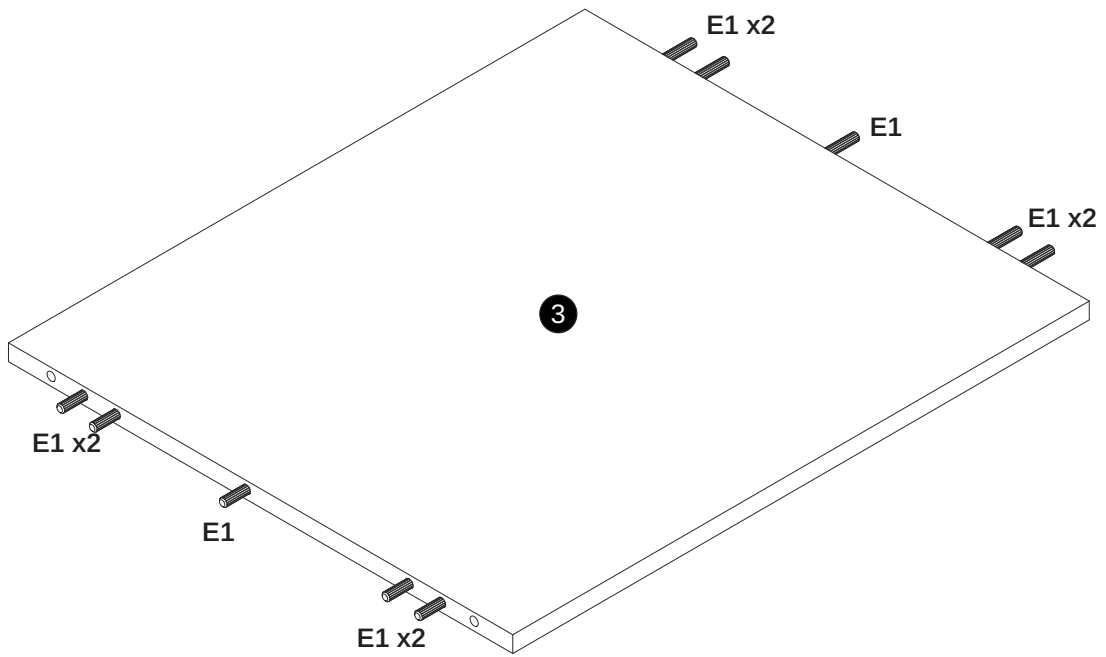

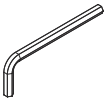

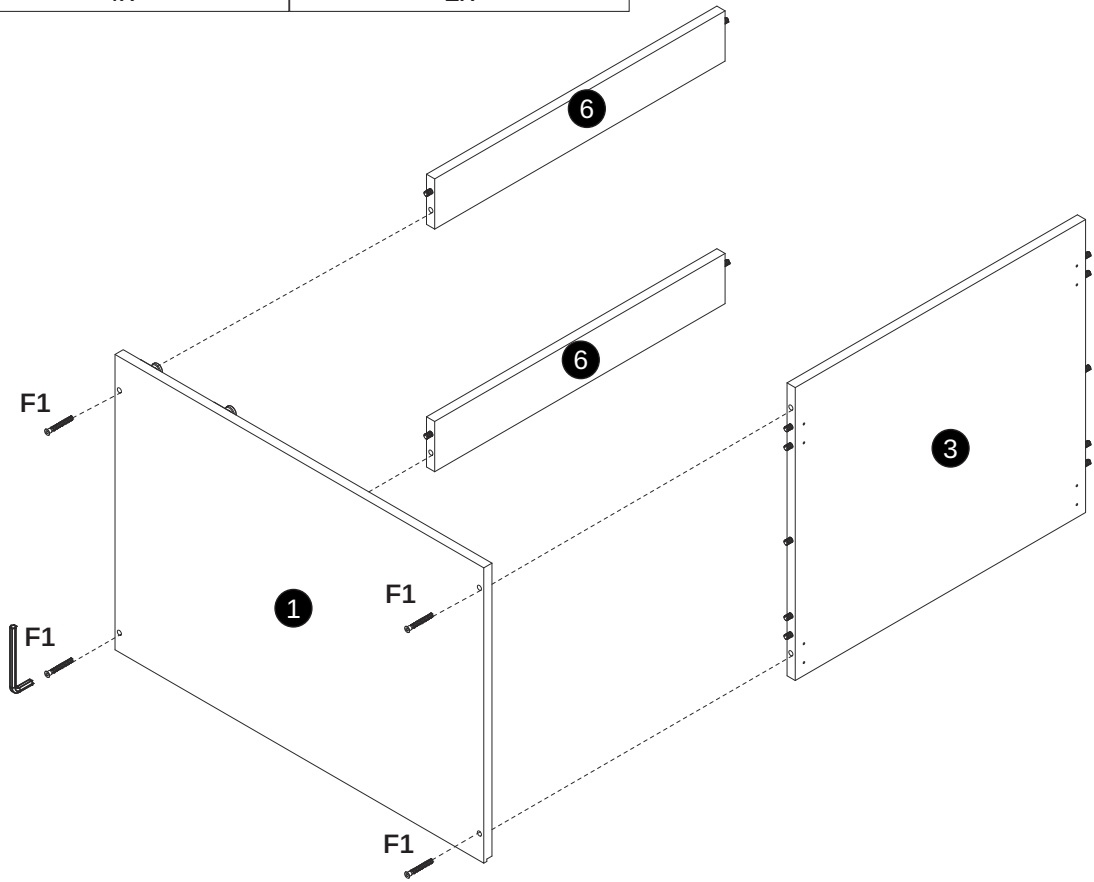
5	F1		K2	
		4x		1x

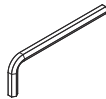

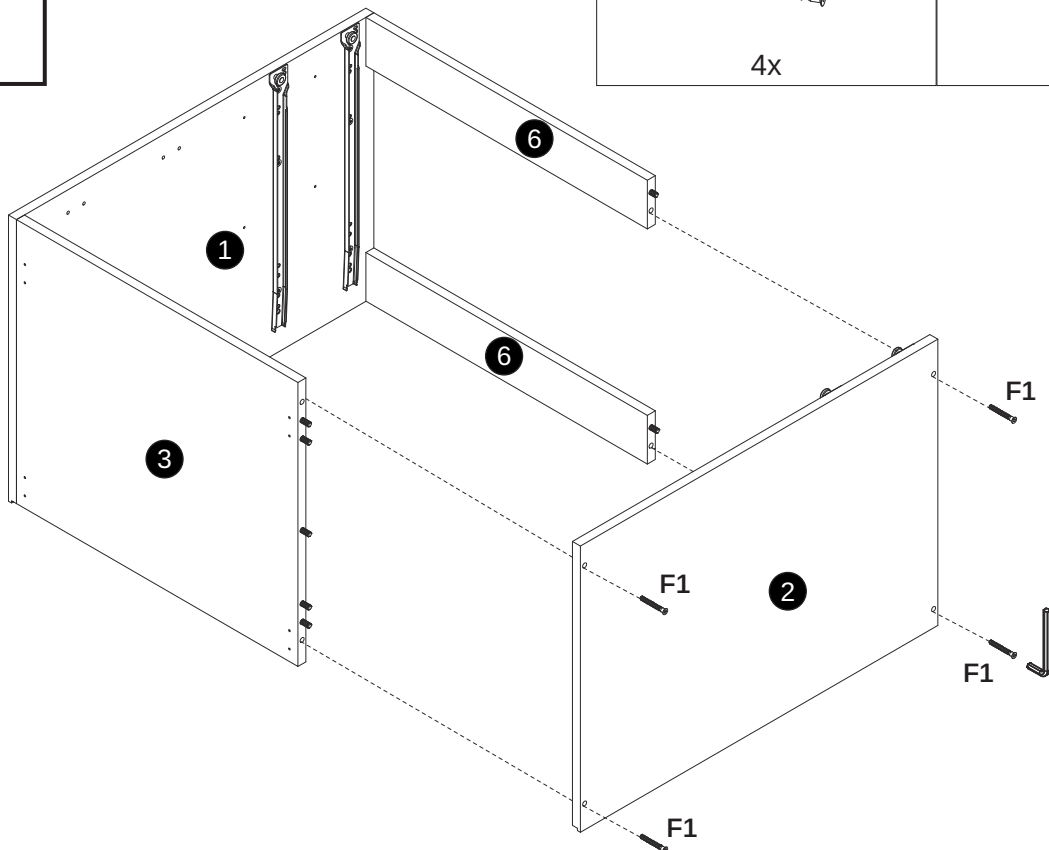

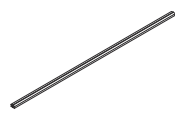
6	F1		K2	
		4x		1x

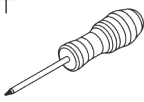

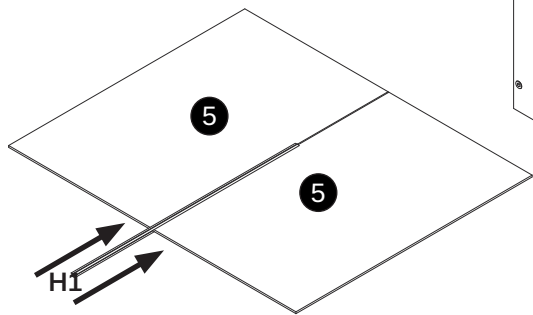
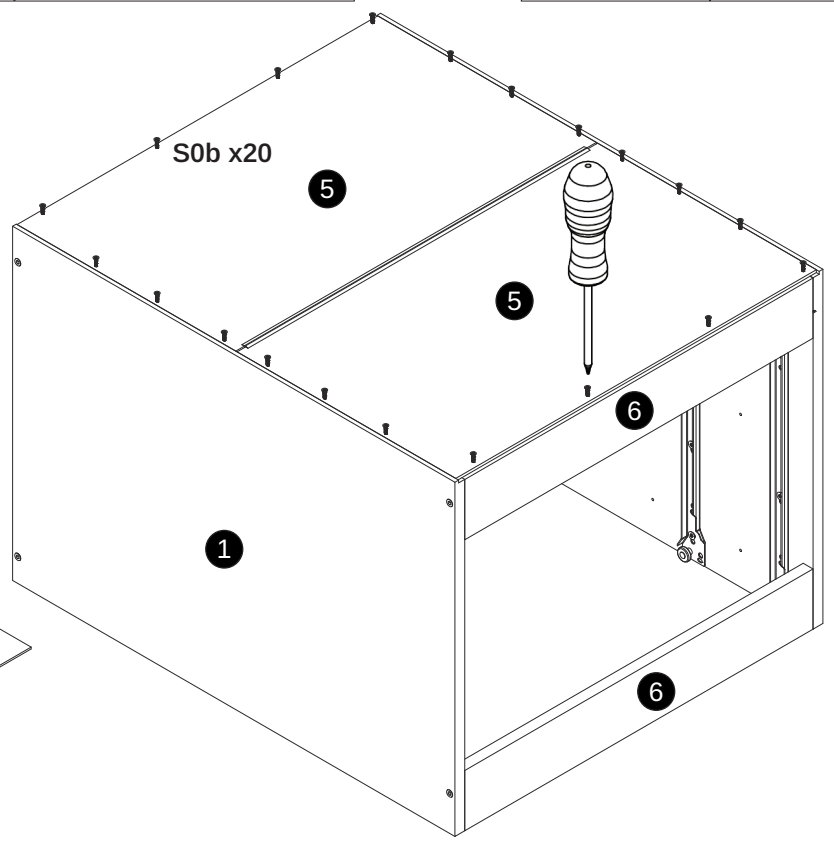
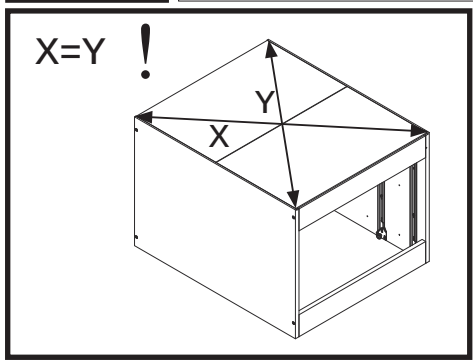
7	S0b		H1			
		20x		1x		

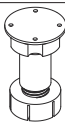

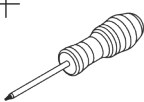
8	U5		S1c		
		4x		16x	

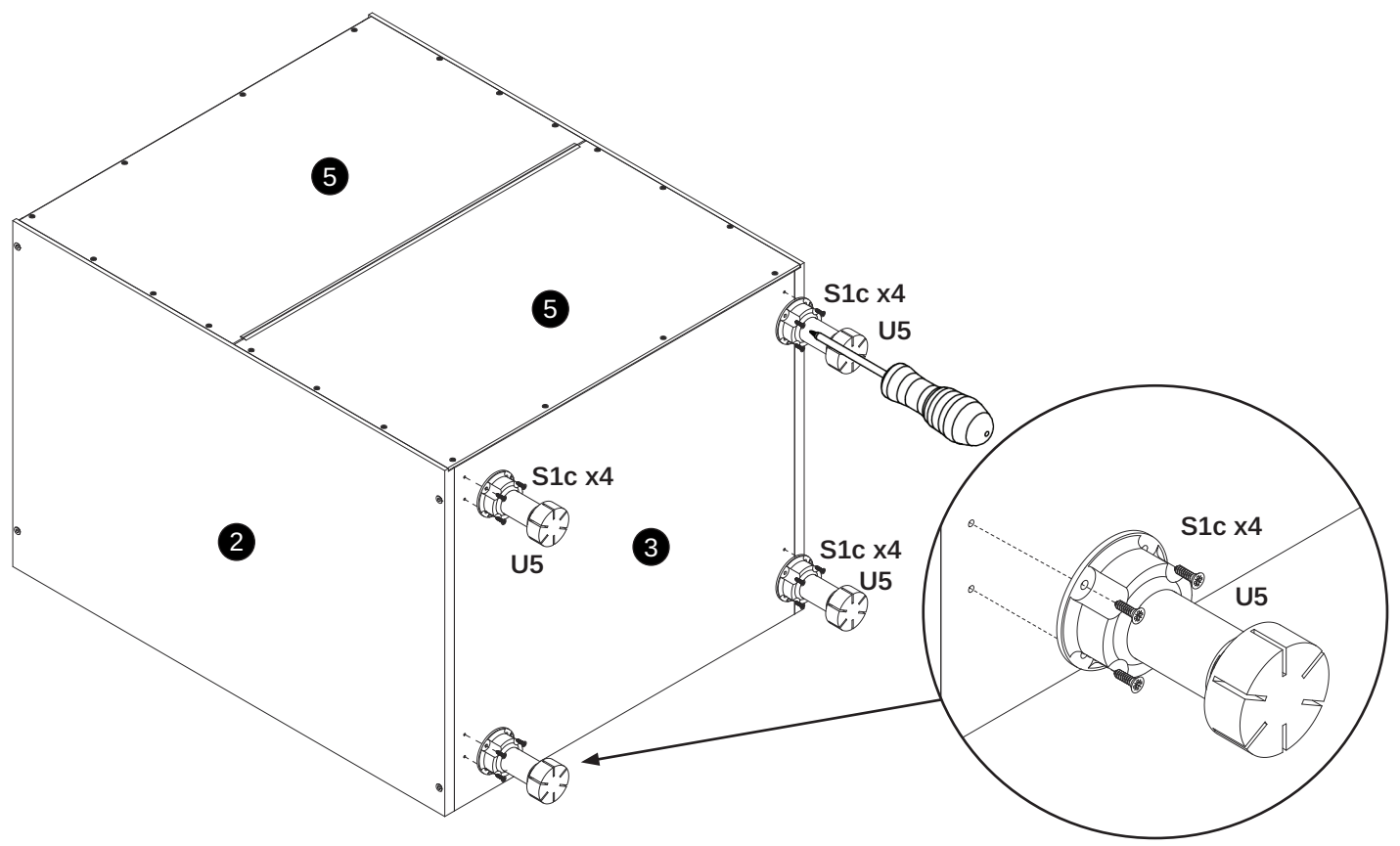

9

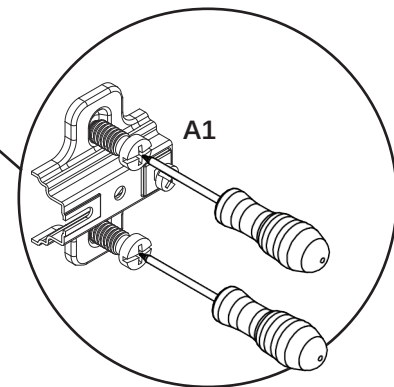
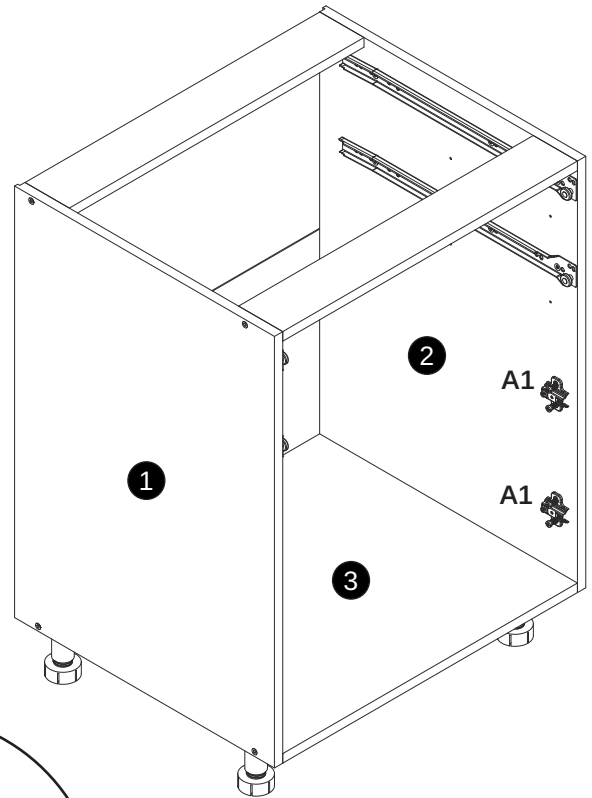
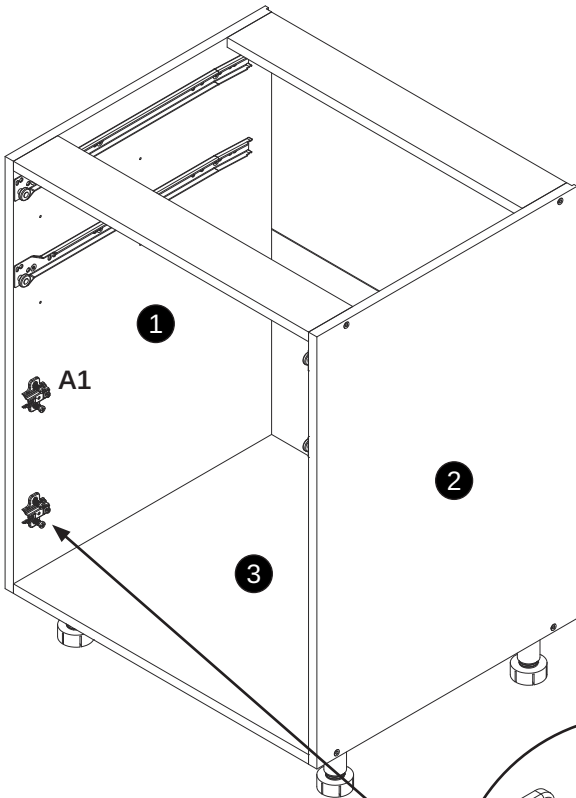
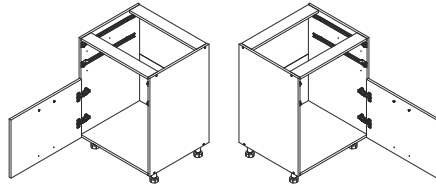
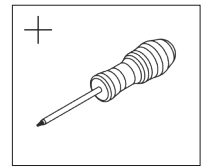
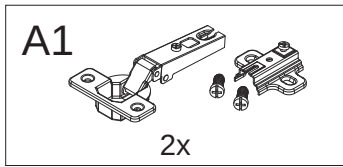

10

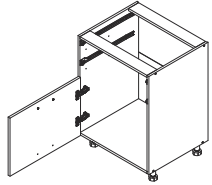
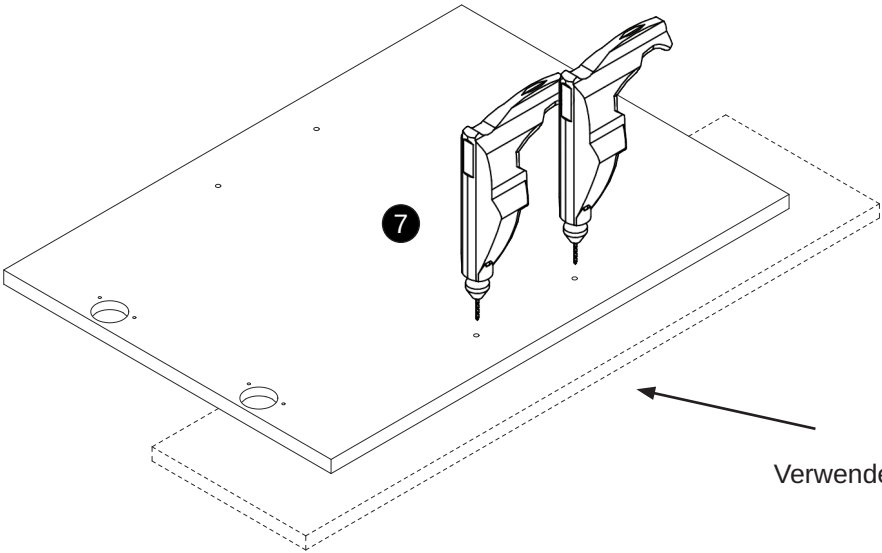
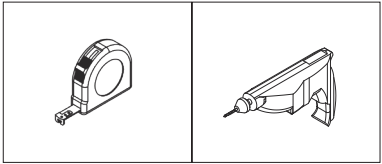
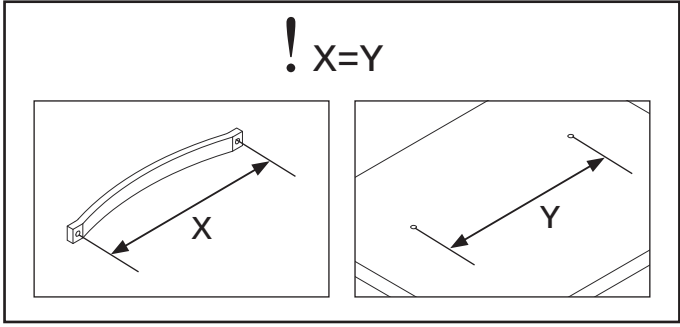

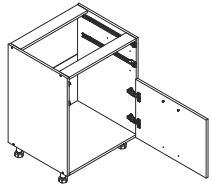
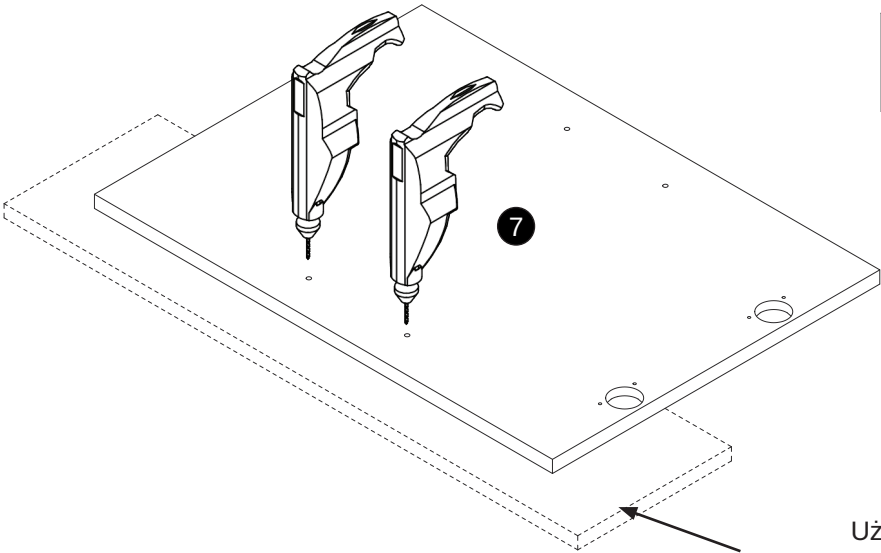

Użyj podkładki !!!
Use a washer !!!
Verwenden Sie eine Montageplatte !!!
Utilisez un tapis !!!





Użyj podkładki !!!
Use a washer !!!
Verwenden Sie eine Montageplatte !!!
Utilisez un tapis !!!

11

U1

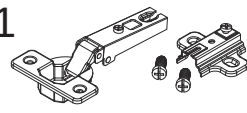
1x

P9

2x

A1

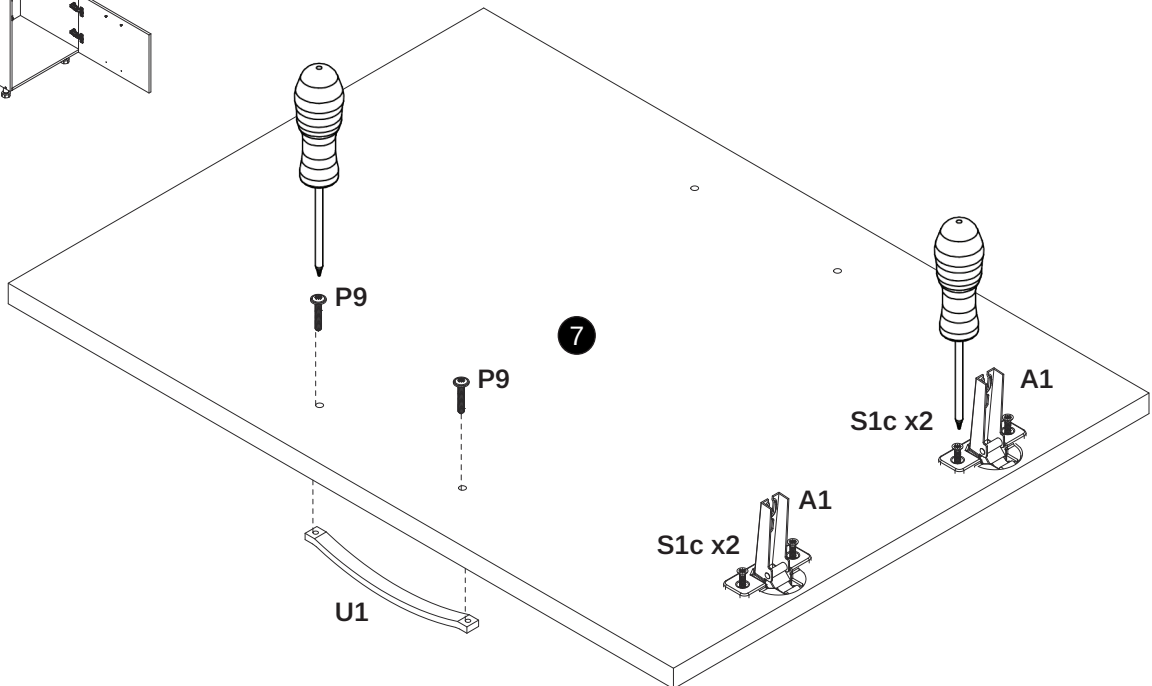
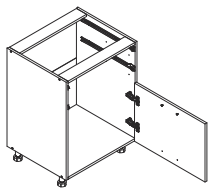
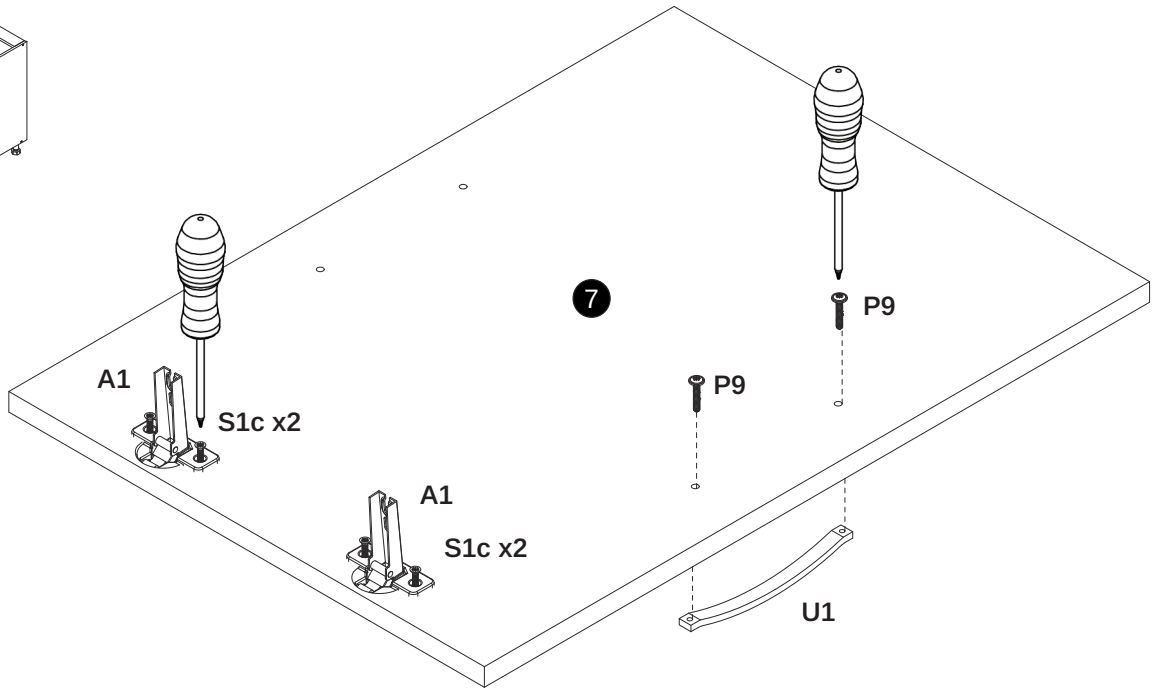
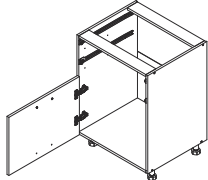
2x



S1c

4x



12

D11
x2

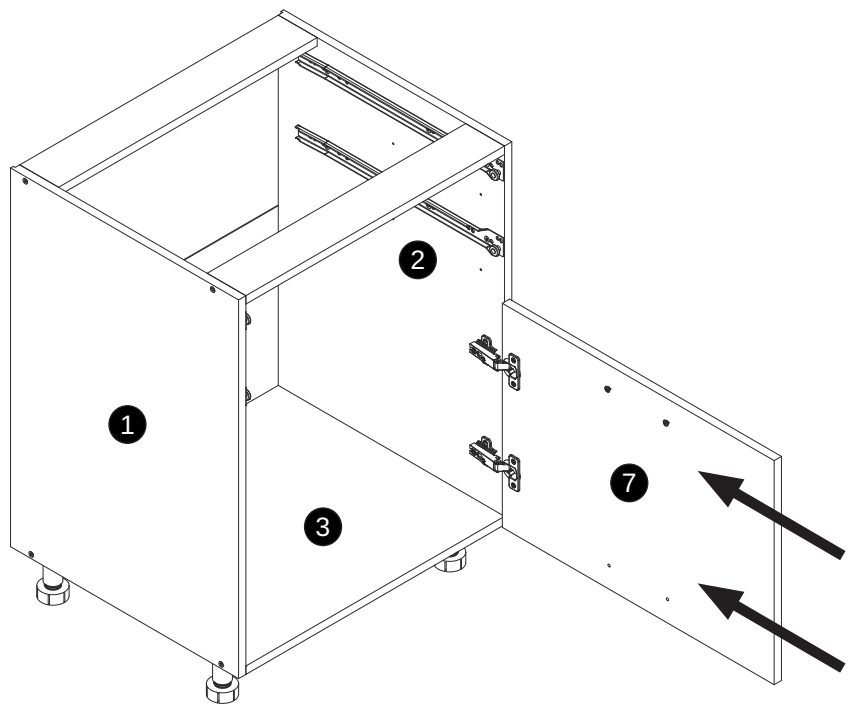
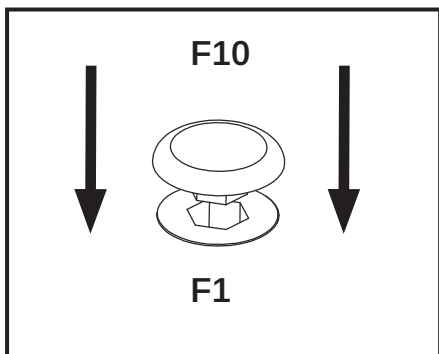
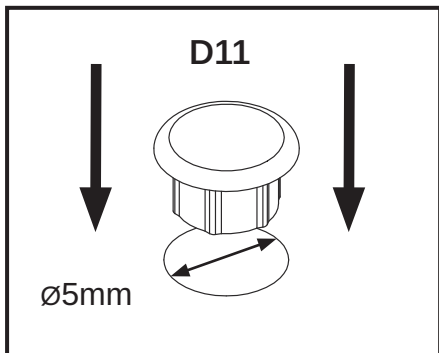
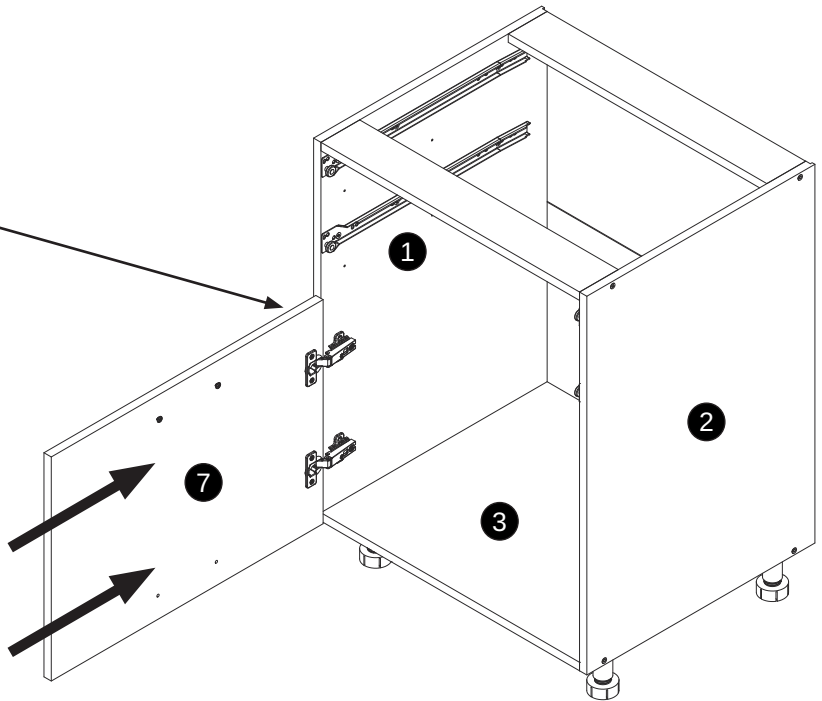
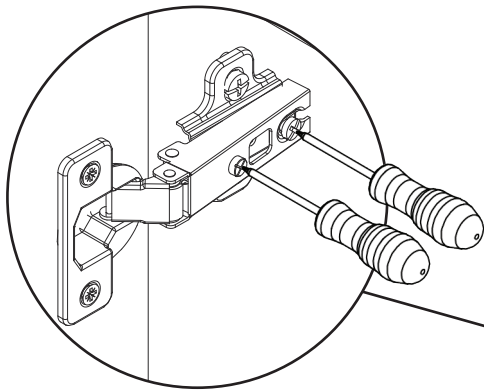
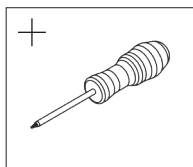
F10
x8



13

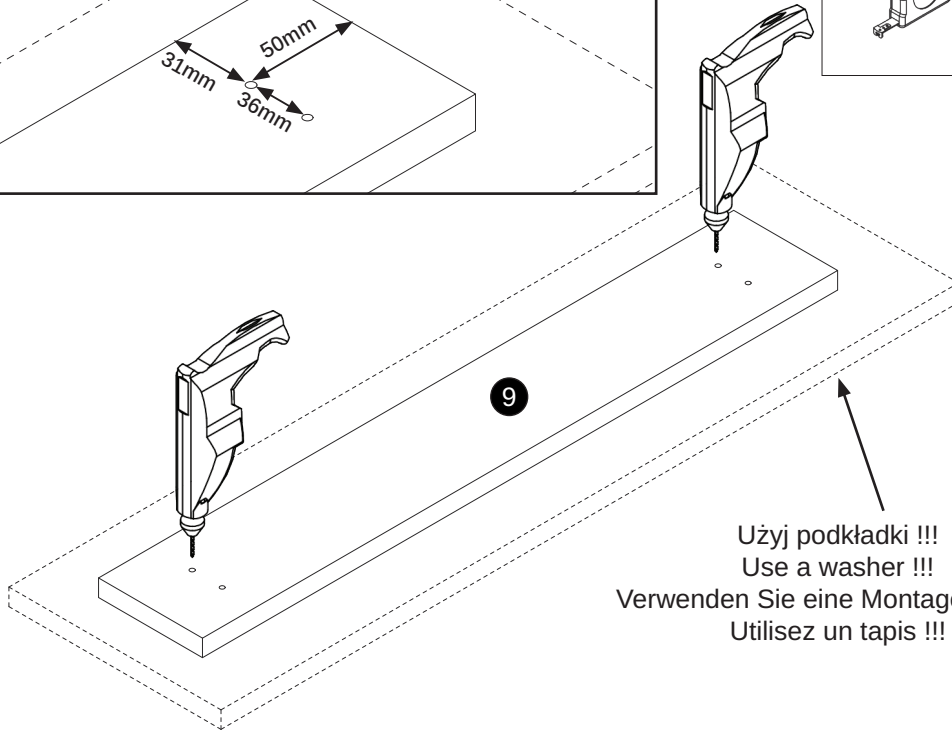
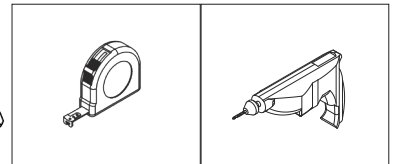
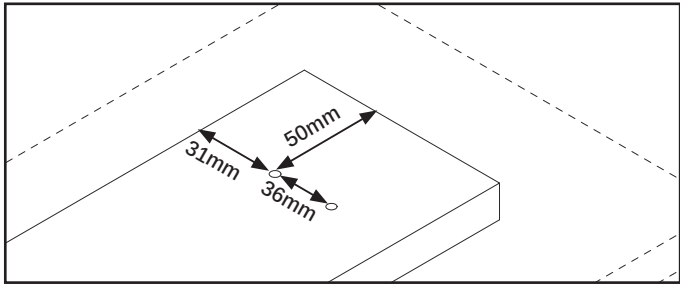

Użyj podkładki !!!
Use a washer !!!
Verwenden Sie eine Montageplatte !!!
Utilisez un tapis !!!

14

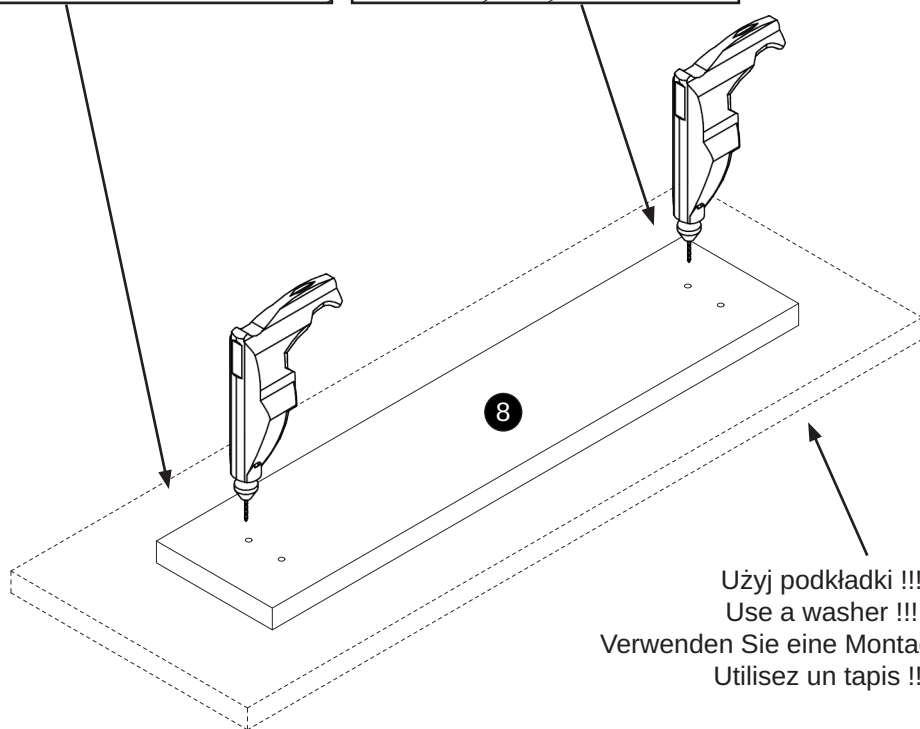
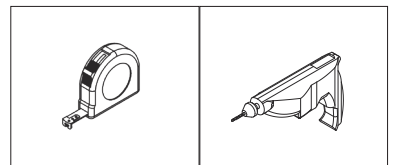
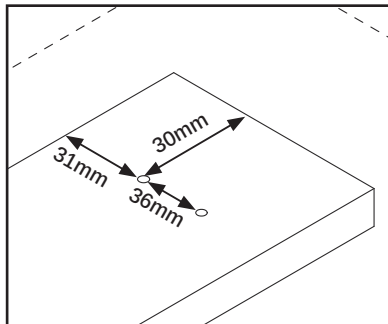
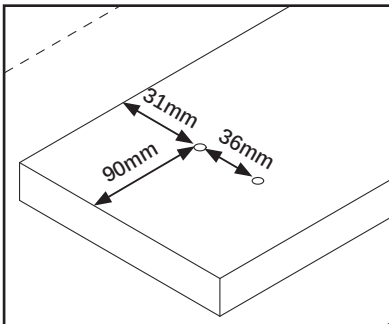

Użyj podkładki !!!
Use a washer !!!
Verwenden Sie eine Montageplatte !!!
Utilisez un tapis !!!

15

U6  2x

S1c  4x

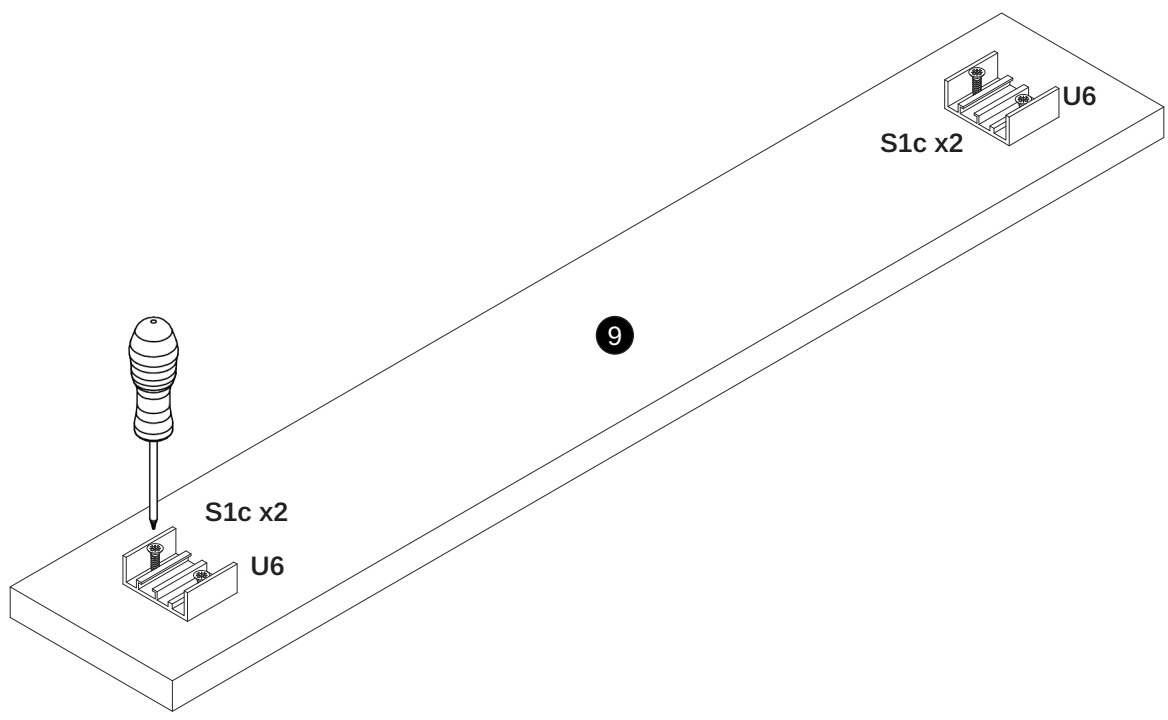
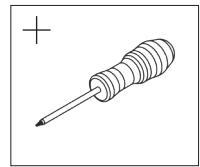

16

U6  2x

S1c  4x

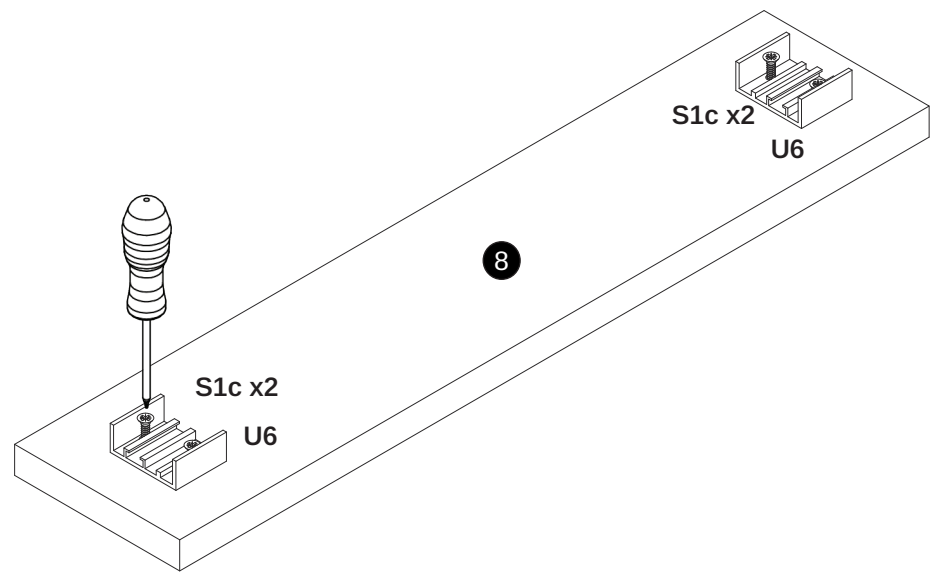
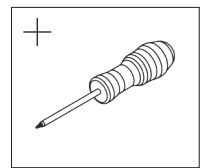

17

R1
2x

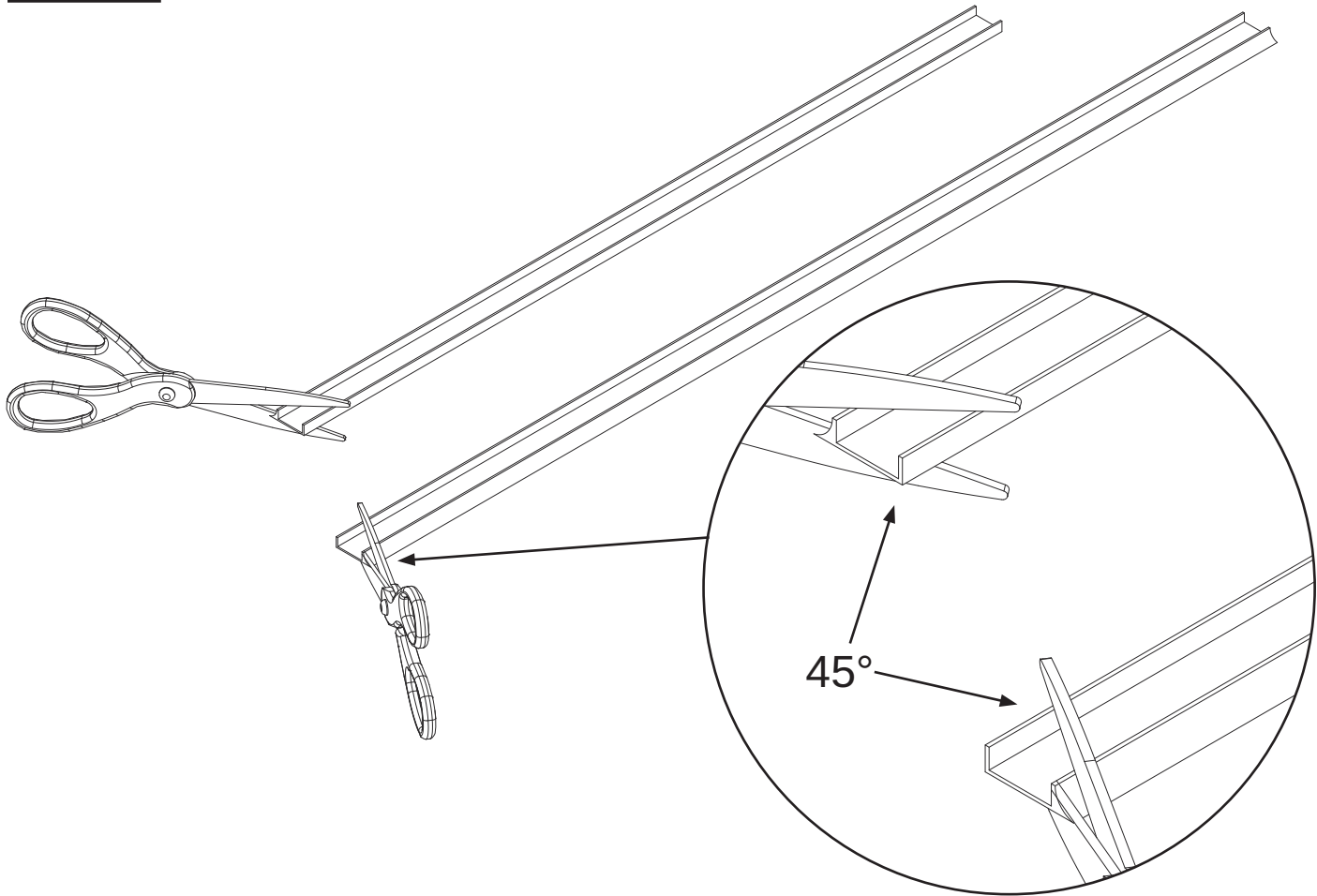
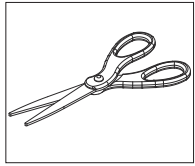

18

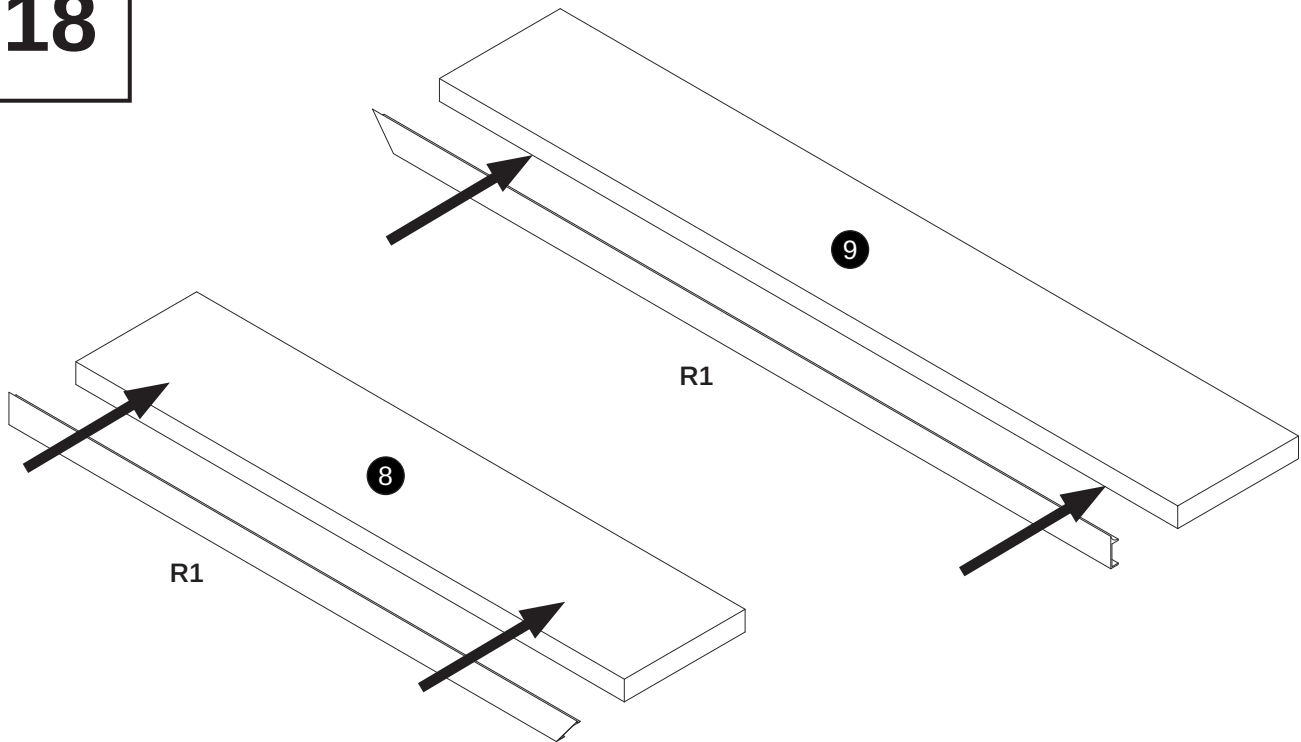

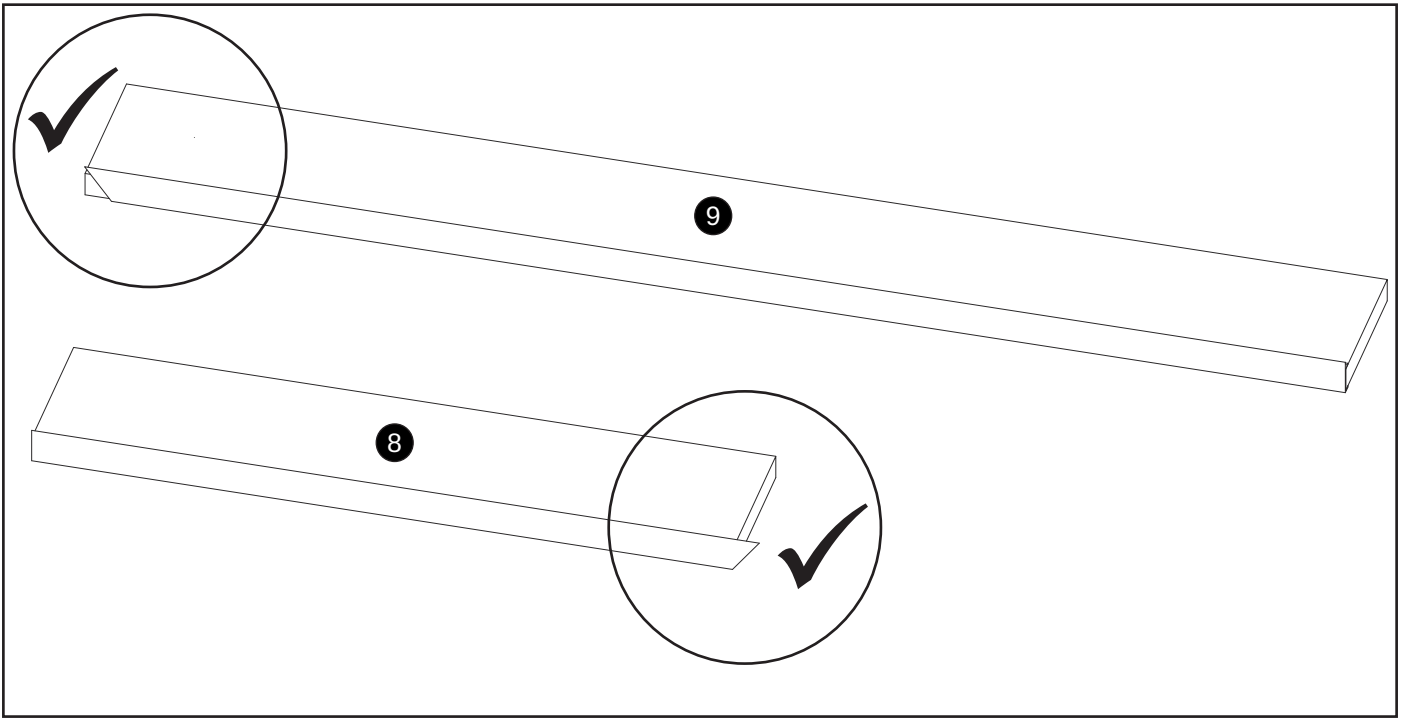

19	U7
	 4x

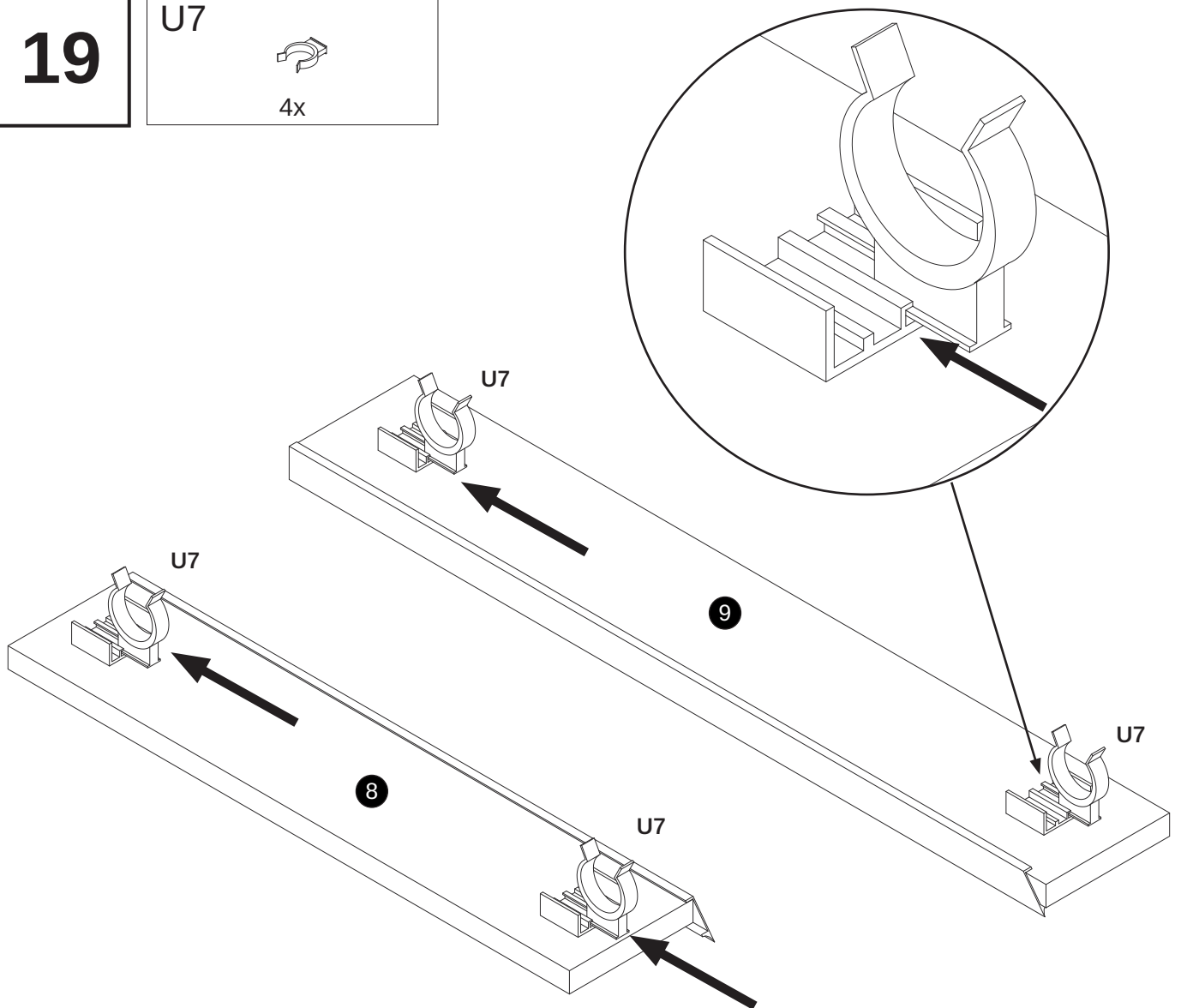

20

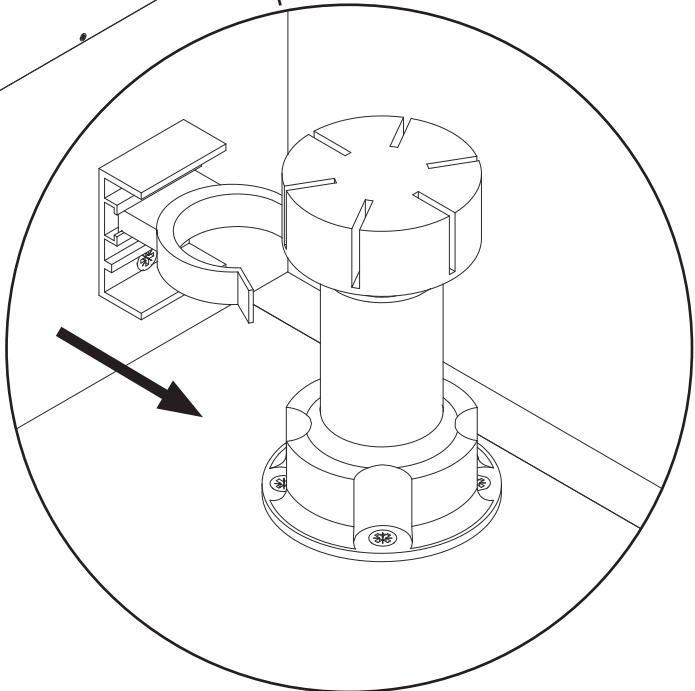
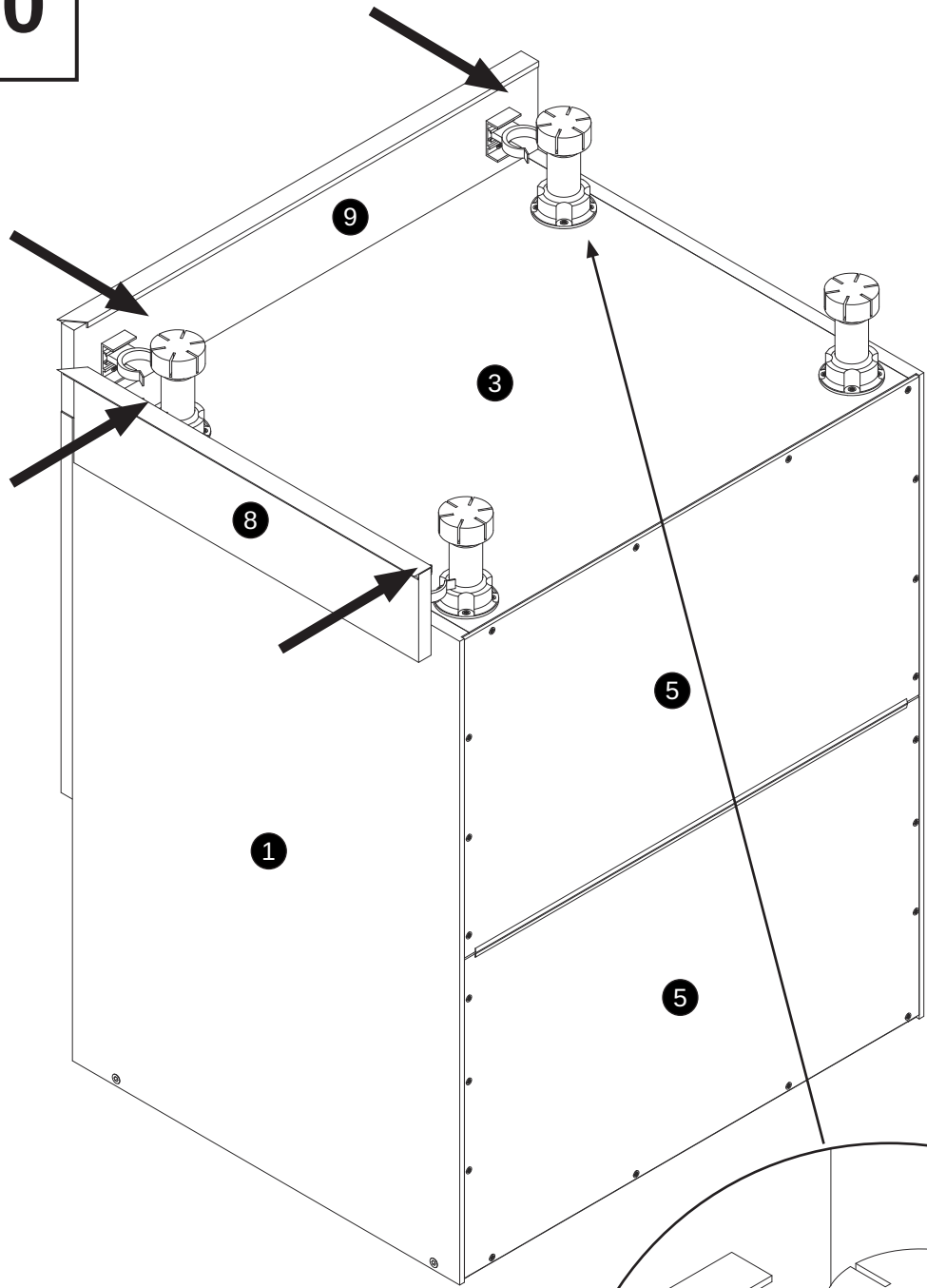

21

S4b



4x

+

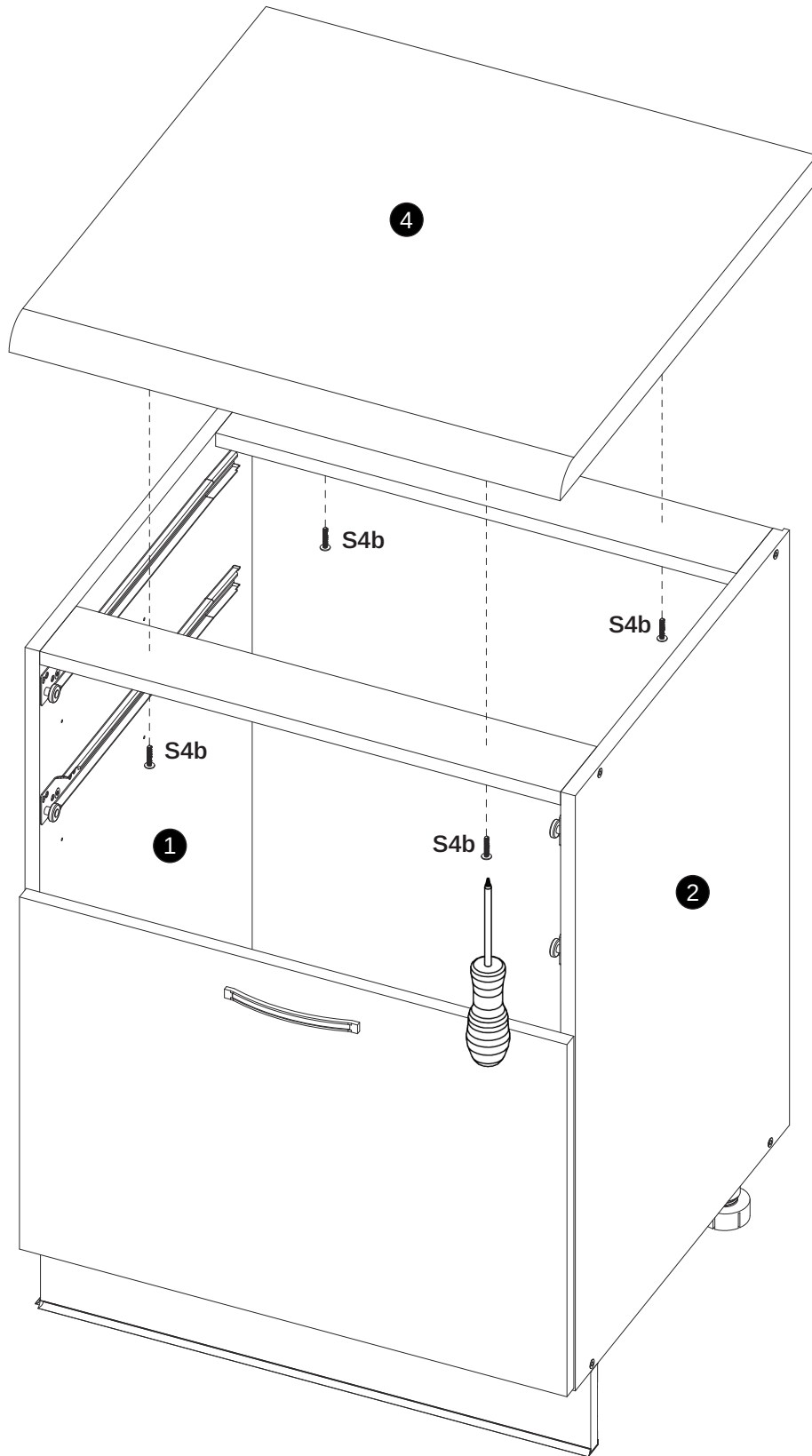

22

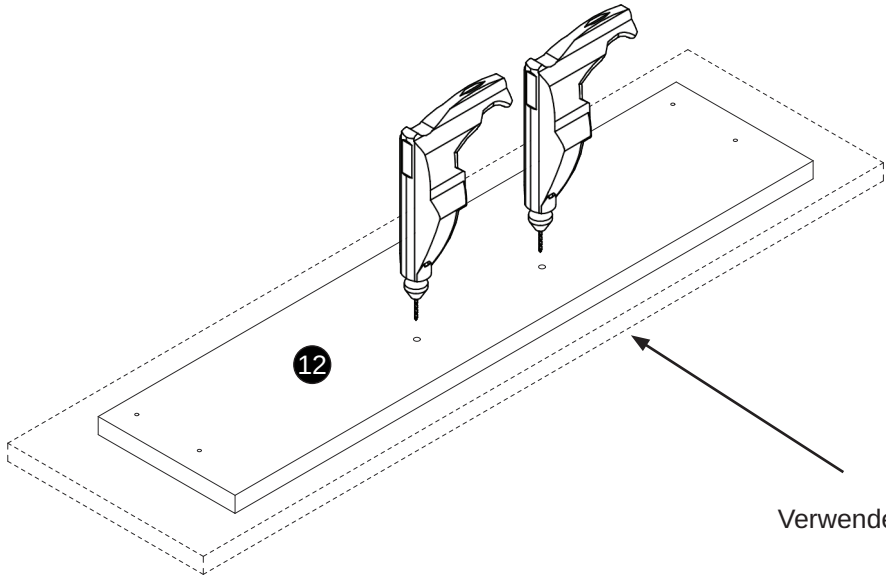
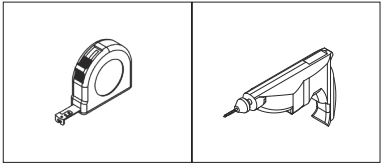
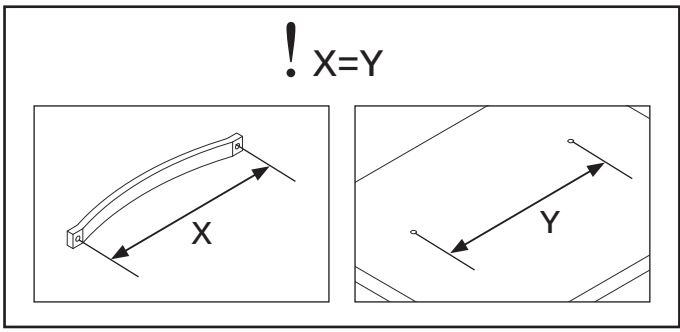

x2

Użyj podkładki !!!
Use a washer !!!
Verwenden Sie eine Montageplatte !!!
Utilisez un tapis !!!

23

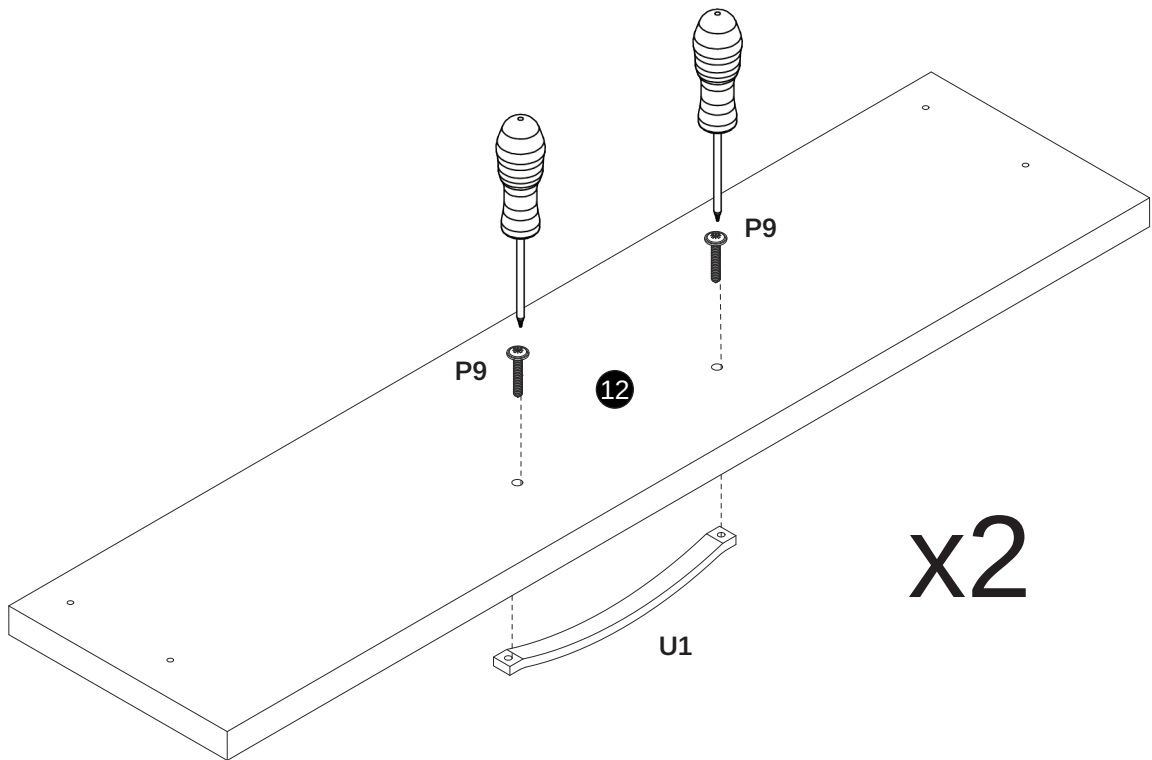
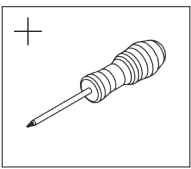
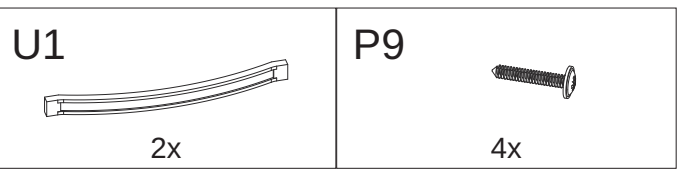

x2

24

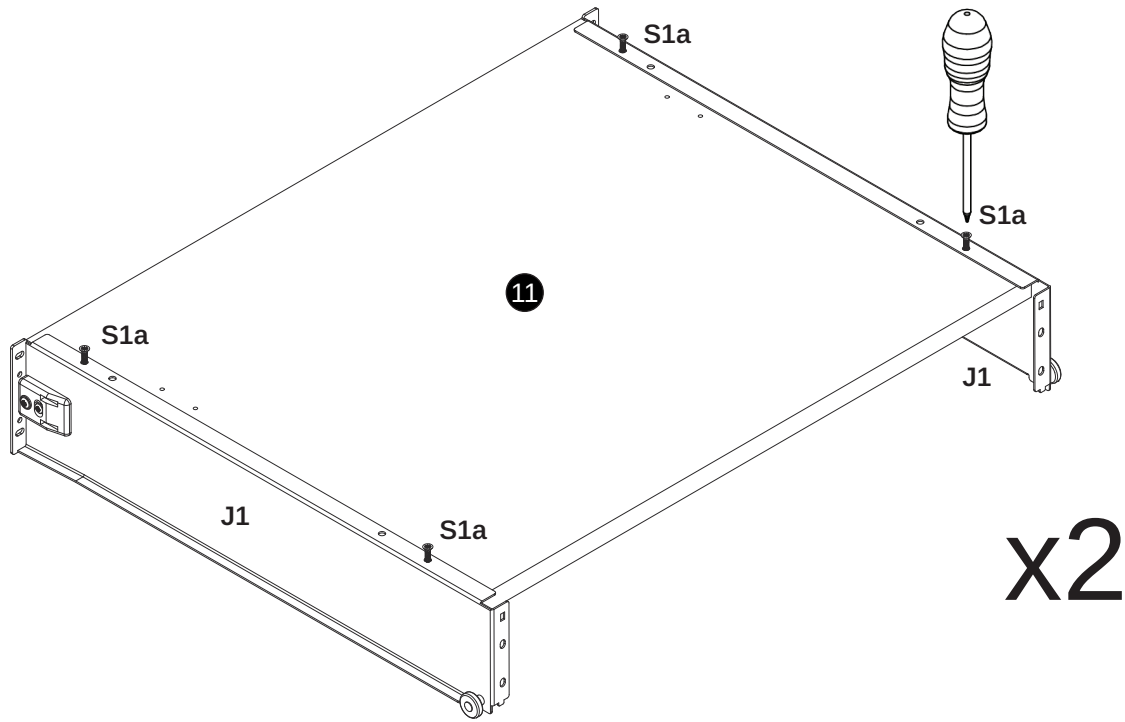
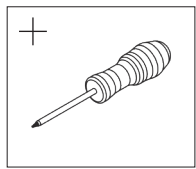
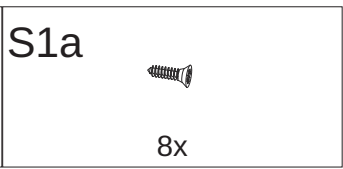
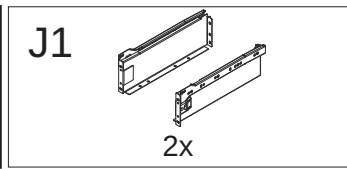

25

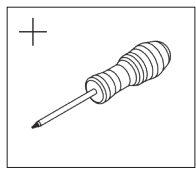
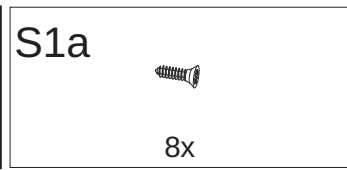

x2

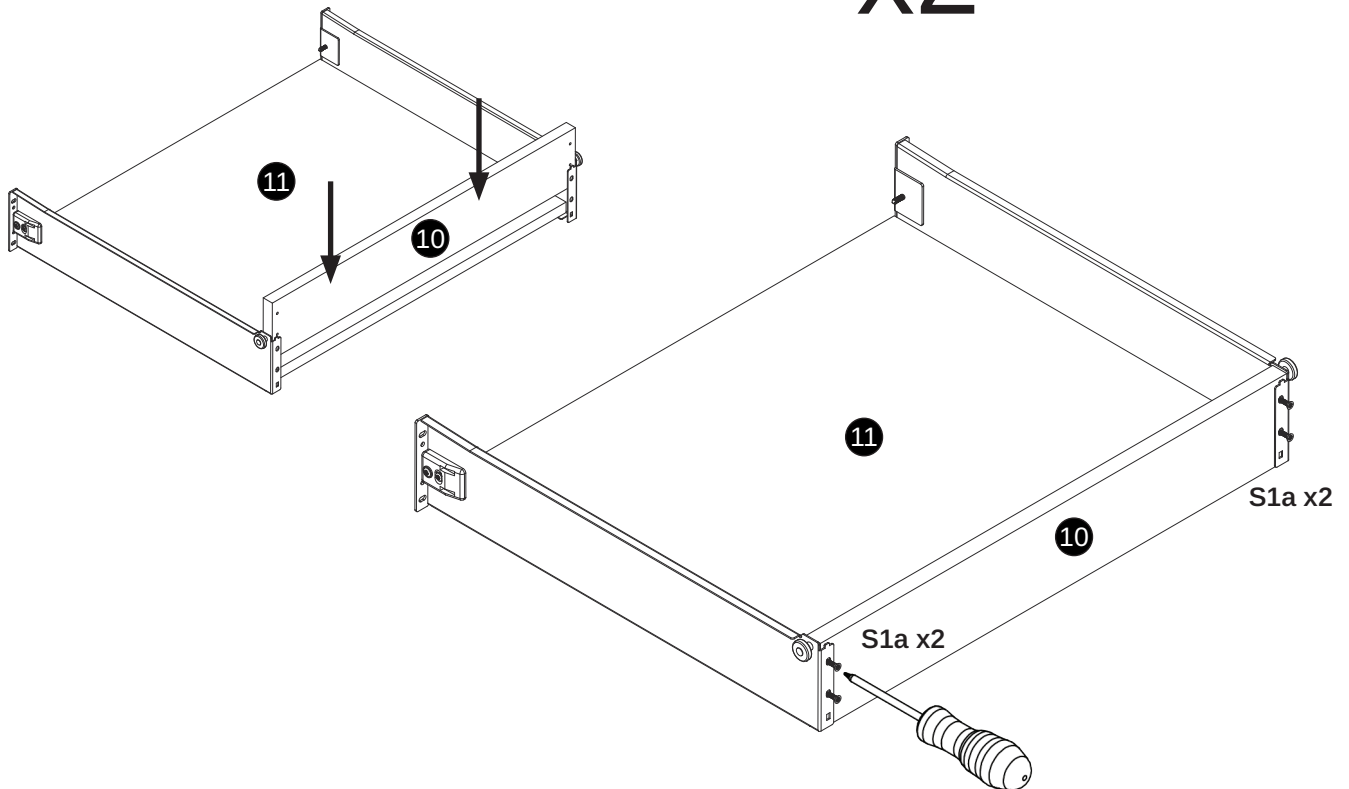

26

S1a
8x

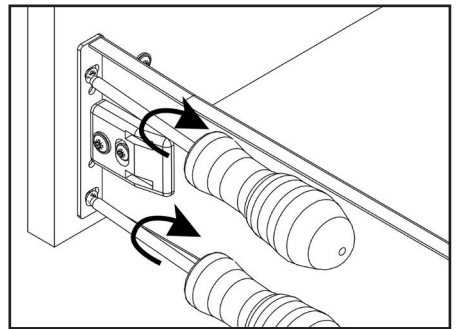
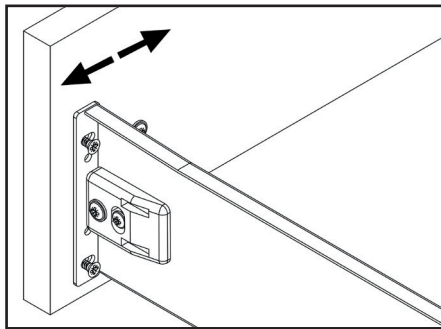
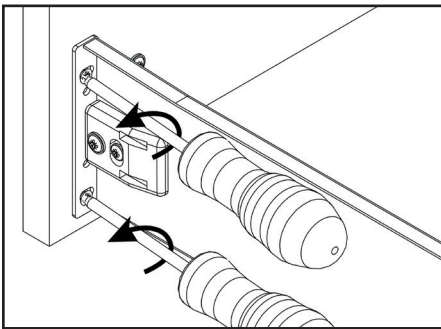
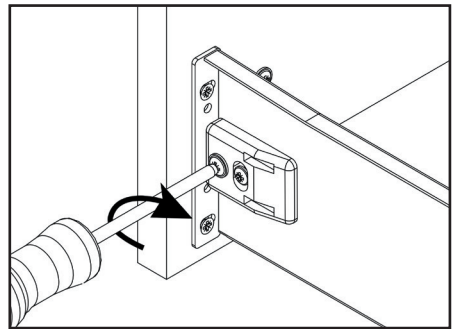
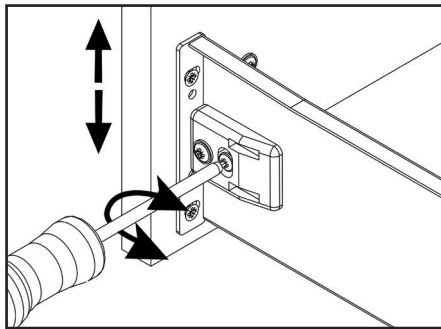
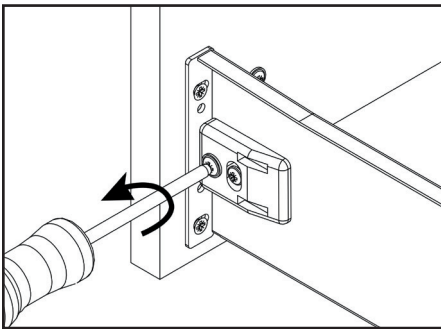
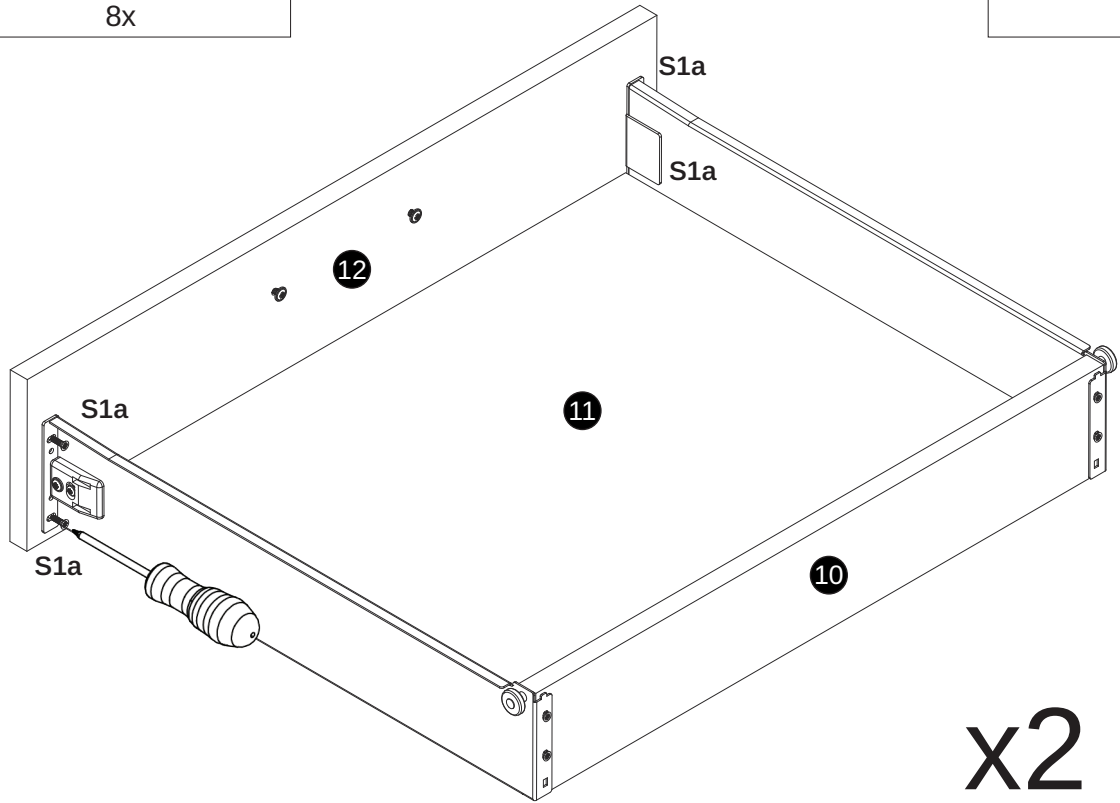
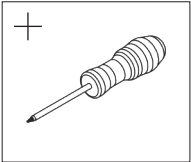

27

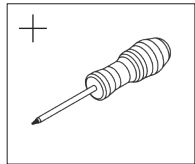
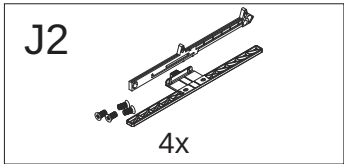

ver.2

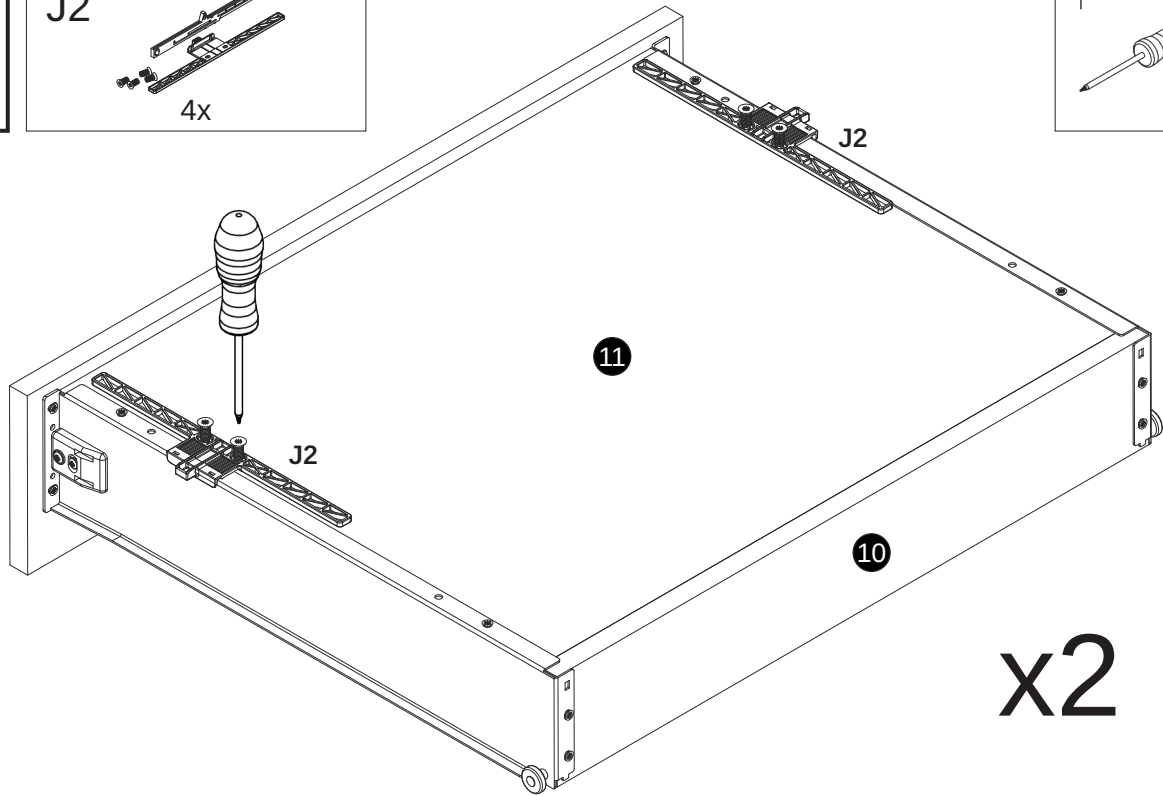

28

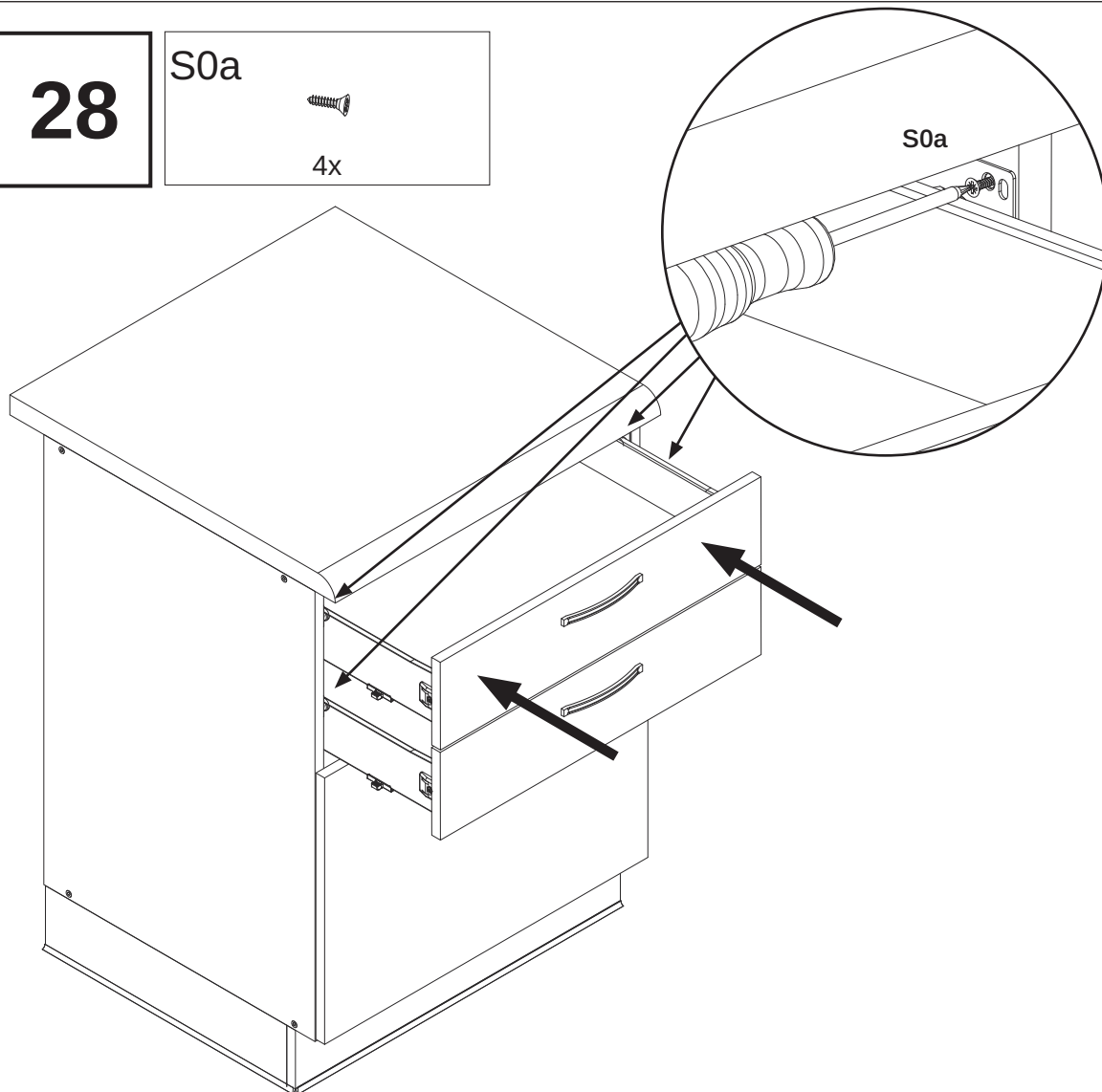
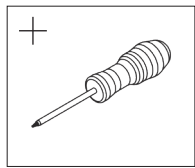
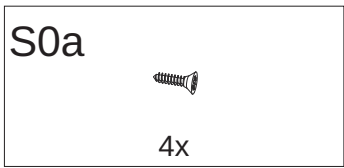

29

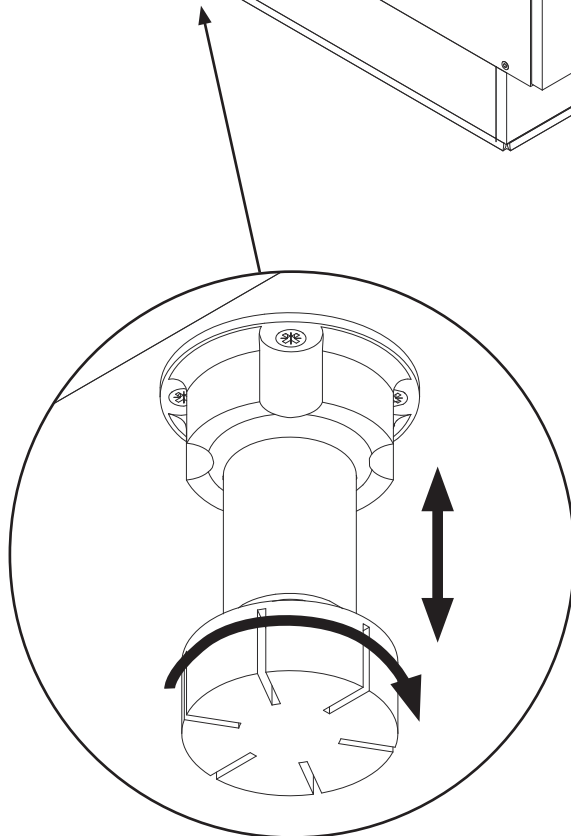
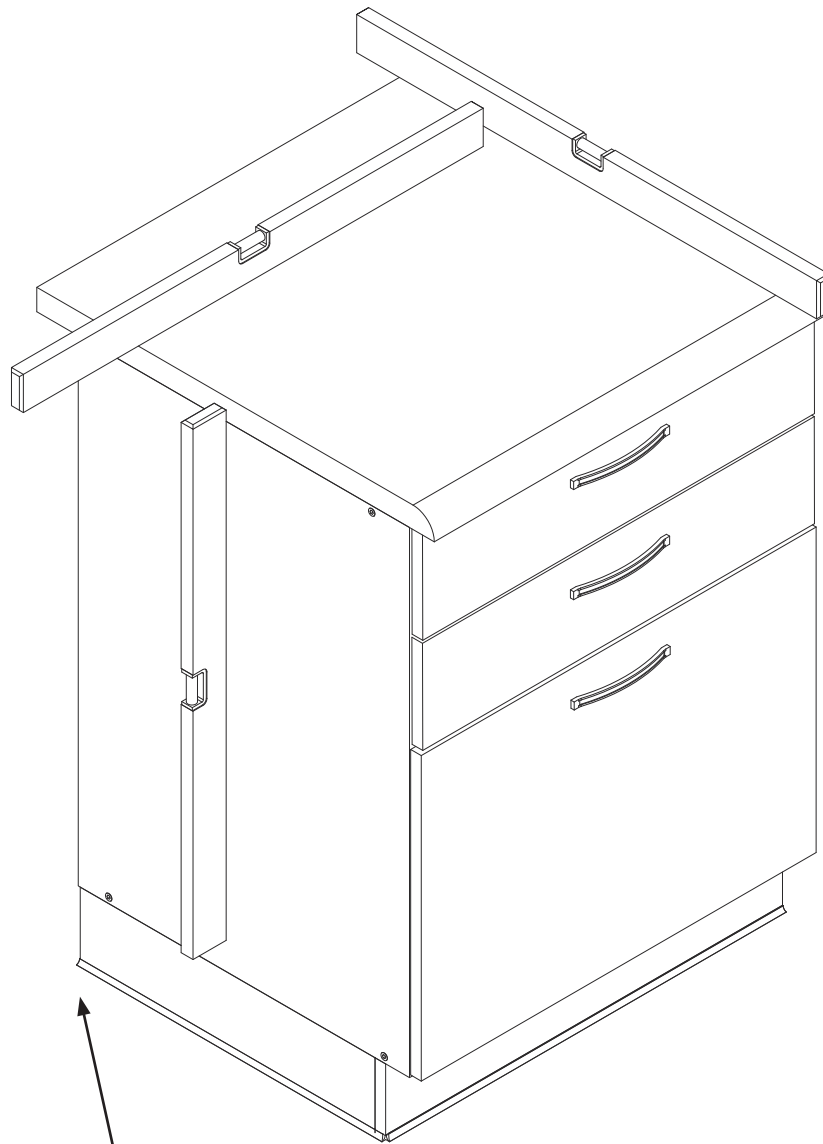
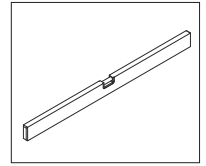

30*

B1



1x

S1c



4x

+



*

Opcjonalnie !
Optionally !
Optional !
En option !

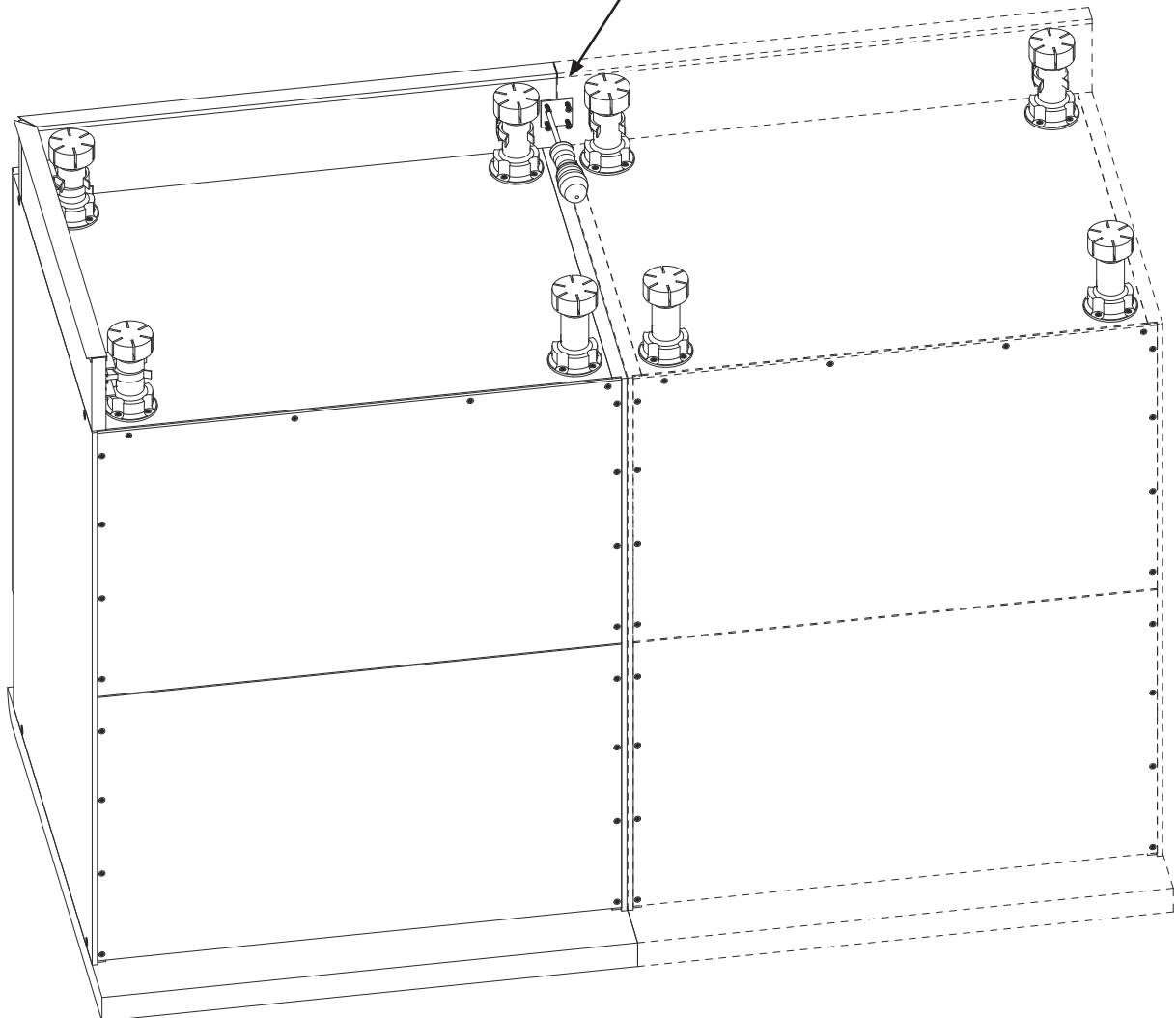
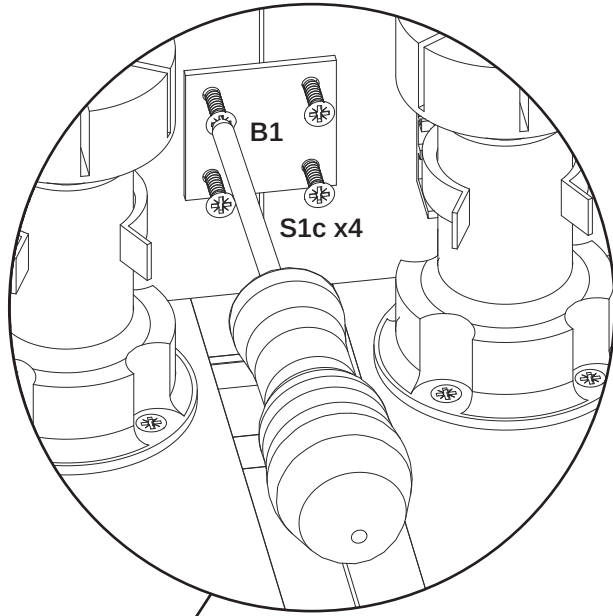

Zasady użytkowania i konserwacji mebli

PL

- Meble należy użytkować w pomieszczeniach suchych, ogrzewanych zabezpieczonych przed szkodliwymi wpływami atmosferycznymi.
- W trakcie użytkowania mebli należy okresowo sprawdzać stan połączeń technicznych takich jak: mimośrodowy, zawiasy, prowadniki.
- Podczas przenoszenia mebli należy chwycić wyłącznie za pionowe elementy konstrukcyjne takie jak boki, nogi. Bezwzględnie nie można chwycić za elementy poziome, takie jak blaty, półki, szuflady, gdyż grozi to poważnymi uszkodzeniami mebli.
- Powierzchnię mebli należy czyścić wyłącznie środkami przeznaczonymi do pielęgnacji mebli.

EN

- Furniture should be kept in dry places which are heated and protected by harmful influence of atmospheric conditions.
- While the furniture is in use there is a necessity to periodically check the state of the technical connections such as: eccentric rods, hinges, guides.
- While furniture is carried it is necessary to keep only the vertical components, such as sides and legs of the furniture.
- The surface of the furniture should be cleaned only with detergents for furniture care.

DE

- Die Möbel soll man in den trockenen, beheizten und vor den schädlichen Witterungseinflüssen gesicherten Räumen benutzen.
- Im Laufe der Benutzung der Möbel soll man zeitlich den Zustand der technischen Verbindungen wie: Exzenter, Türbänder und Leitstücke prüfen.
- Während des Möbeltransports muss man ausschließlich nach vertikalen Konstruktionselementen wie: Ecken und Beine greifen. Auf keinen Fall darf man nach horizontalen Elementen, wie Blätter, Bretter und Schubladen greifen, was zur ernsthaften Möbelbeschädigung bringen kann.
- Die Fläche der Möbel soll man nur mit dazu geeigneten Pflegemöbelmitteln putzen.

FR

- Les meubles doivent être utilisés dans des pièces sèches, chauffées et protégées contre les effets nocifs de la pollution. Les meubles doivent être utilisés dans des locaux secs, chauffés et protégés des influences atmosphériques nocives.
- Lors de l'utilisation du mobilier, l'état des connexions techniques telles que: excentriques, charnières, guides.
- Lorsque vous déplacez le meuble, ne manipulez que les éléments structurels verticaux, tels que les côtés, jambes. Vous ne devez absolument pas saisir les éléments horizontaux tels que les plateaux, les étagères, les tiroirs, car cela peut provoquer des dommages importants au mobilier.
- La surface du meuble doit être nettoyée uniquement avec des produits destinés à l'entretien des meubles.



Szafka SDZ60 (60x60x82)

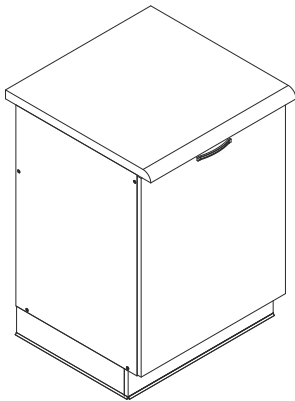

Ilość potrzebnych osób
Number of people needed
Benötigte Personenzahl
Nombre de personnes nécessaires

Niezbędne narzędzia do montażu

Tools necessary for assembly

Notwendiges Werkzeug für die Montage

Outils nécessaires pour le montage

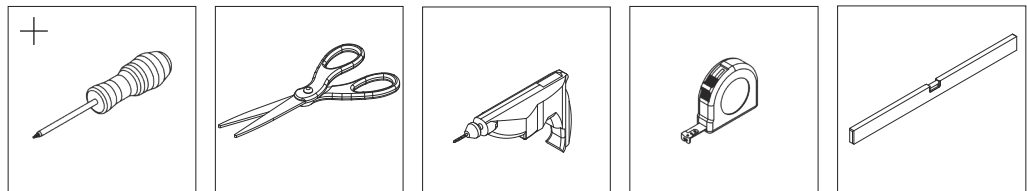

PL

- Przed przystąpieniem do montażu przeczytaj i zapoznaj się z całą instrukcją.
- Przestrzegaj bezwzględnie kolejnych kroków montażowych **1**, **2**, **3**...
- Nie wyrzucaj opakowania dopóki nie ukończysz skutecznie w całości montażu.
- Montaż wykonuj na płaskiej, miękkiej oraz czystej powierzchni takiej jak tektura.
- Bezwzględnie nie montuj elementów jeśli zauważysz ich wady lub uszkodzenia.
- Elementy montażowe takie jak okucia trzymaj w miejscu niedostępnym dla niemowląt i dzieci.
- Wadliwe lub uszkodzone elementy reklamuj podając ich numer z instrukcji montażu.
- Jeśli uszkodzony element będzie zamontowany reklamacja nie będzie uznana.

EN

- Read and get familiar with the whole instruction before the process of installation.
- Imperatively observe the consecutive assembly steps **1**, **2**, **3**...
- Do not throw away the packaging until the installation is successfully done.
- The installation should be done on the flat, soft and clear surface, such as cardboard.
- Under no circumstances should you install the elements in case of any faults or damage.
- The installation elements as fittings should be kept in a place unavailable for babies or children.
- Faulty or damaged components should be complaint by giving the number of the assembly instruction.
- If the damaged component is installed, the complaint will not be accepted.

DE

- Vor Beginn der Montage muss man die Instruktion genau durchlesen.
- Die aufeinanderfolgenden Montageschritte **1**, **2**, **3**... unbedingt beachten.
- Man muss die Packung behalten bis man die ganze Montage erfolgreich nicht beendet.
- Die Montage muss man auf einer glatten, weichen und sauberen Fläche ausüben
- Fehlerhafte oder beschädigte Elemente darf man auf keinen Fall montieren. Auf keinen Fall darf man fehlerhafte oder beschädigte Elemente montieren.
- Die Montageelemente wie Beschläge muss man unzugänglich von Babys und Kindern halten.
- Fehlerhafte oder beschädigte Elemente muss man nur mit Nummer der Instruktion reklamieren.
- Falls das beschädigte Element montiert wird, wird die Reklamation nicht berücksichtigt.







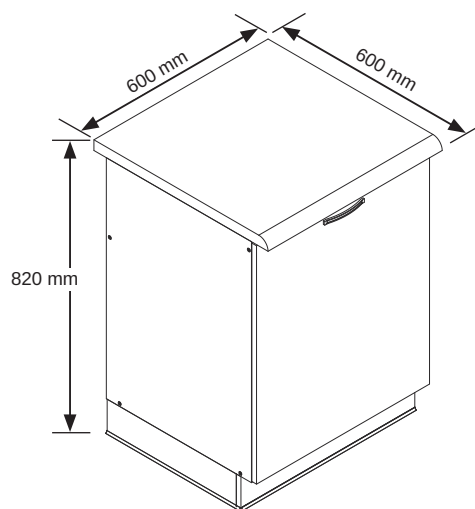



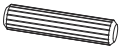

FR

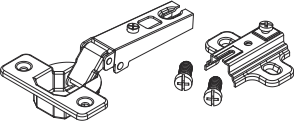
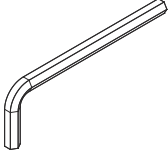
- Avant de commencer le montage, lire et prendre connaissance de l'intégralité du manuel.
- Respectez scrupuleusement les étapes d'installation suivantes **1**, **2**, **3**...
- Ne pas jeter l'emballage avant d'avoir terminé l'assemblage.
- Le montage doit être effectué sur une surface plane, souple et propre, comme du carton.
- Ne pas assembler si vous remarquez des défauts ou des dommages.
- Garder les éléments de montage tels que les raccords hors de portée des bébés et des enfants.
- Réclamer les pièces défectueuses ou endommagées en citant le numéro figurant dans les instructions de montage.
- Si l'article endommagé est installé, la plainte ne sera pas acceptée.

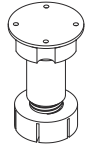
SZAFKA SDZ60

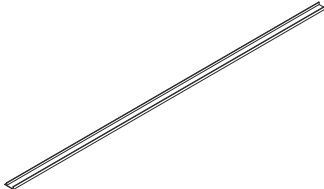

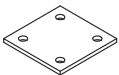

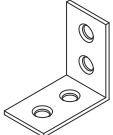
Okucia / Fittings / Beschläge / Embouts

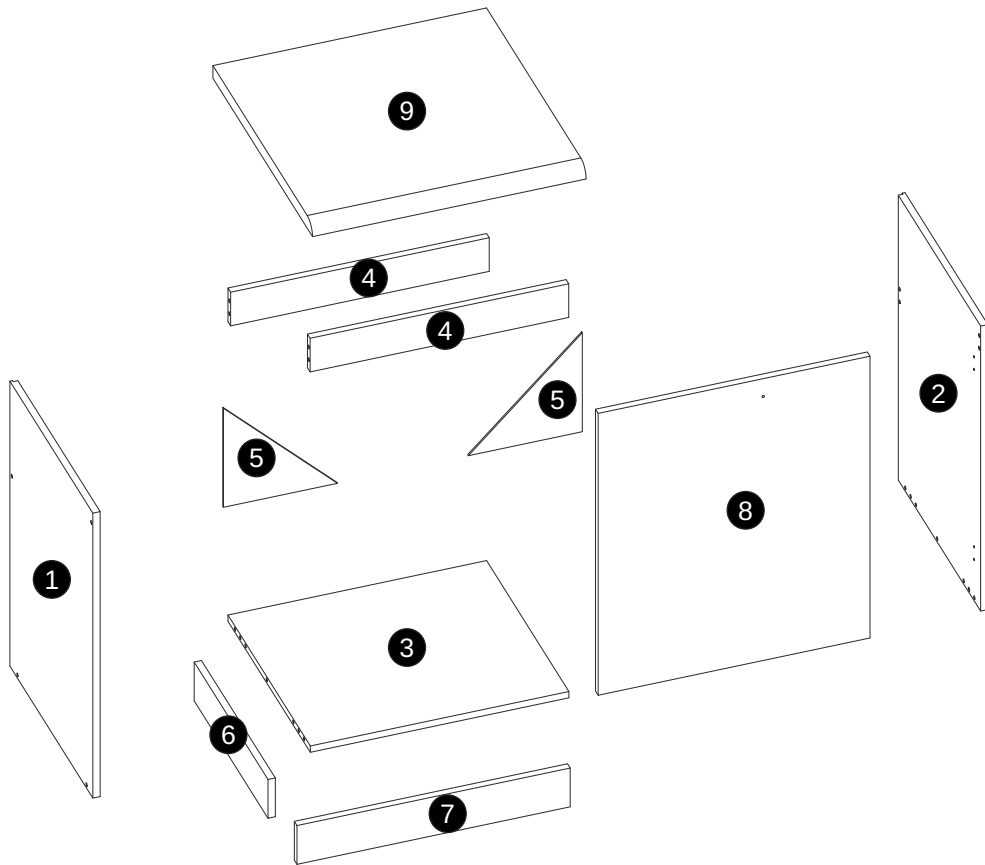
<p>E1</p>  <p>x14</p>	<p>U1</p>  <p>x1</p>	<p>F1</p>  <p>7x50mm</p> <p>x8</p>	<p>P9</p>  <p>4x27mm</p> <p>x2</p>
<p>A1</p>  <p>x2</p>	<p>K2</p>  <p>x1</p>	<p>S1c</p>  <p>3,5x16mm</p> <p>x40</p>	<p>U5</p>  <p>x4</p>
<p>S0b</p>  <p>3x16mm</p> <p>x12</p>	<p>D11</p>  <p>x2</p>	<p>R1</p>  <p>x2</p>	<p>F10</p>  <p>x8</p>
<p>B1</p>  <p>x1</p>	<p>U6</p>  <p>x4</p>	<p>U7</p>  <p>x4</p>	<p>D13</p>  <p>x4</p>

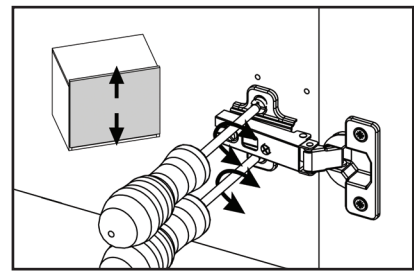
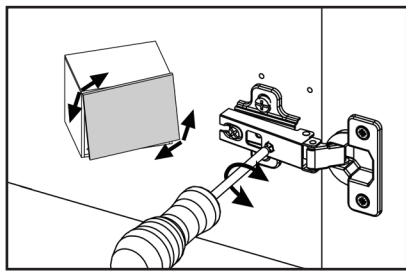
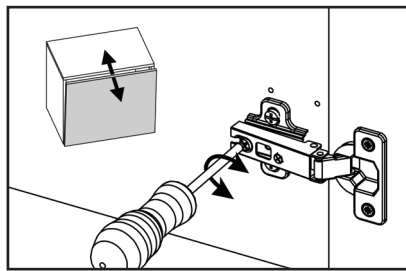

SDZ60	
①	1x (720x500mm)
②	1x (720x500mm)
③	1x (567x496mm)
④	2x (567x85mm)
⑤	2x (250x250mm)
⑥	1x (445x98mm)
⑦	1x (599x98mm)
⑧	1x (596x712mm)
⑨	1x (600x600mm)



1	E1	
		10x

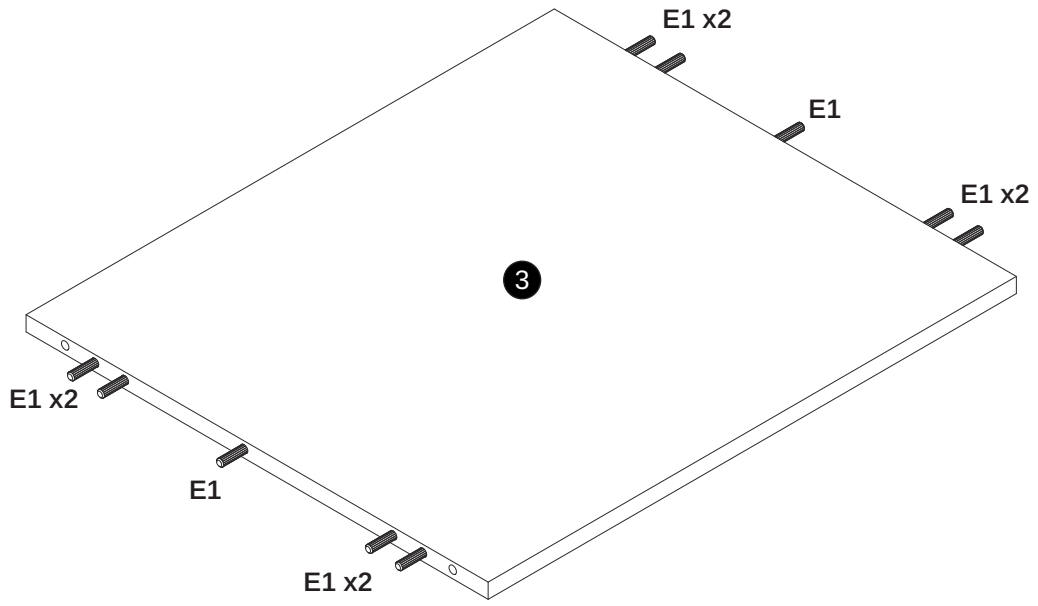

2	E1	
		4x

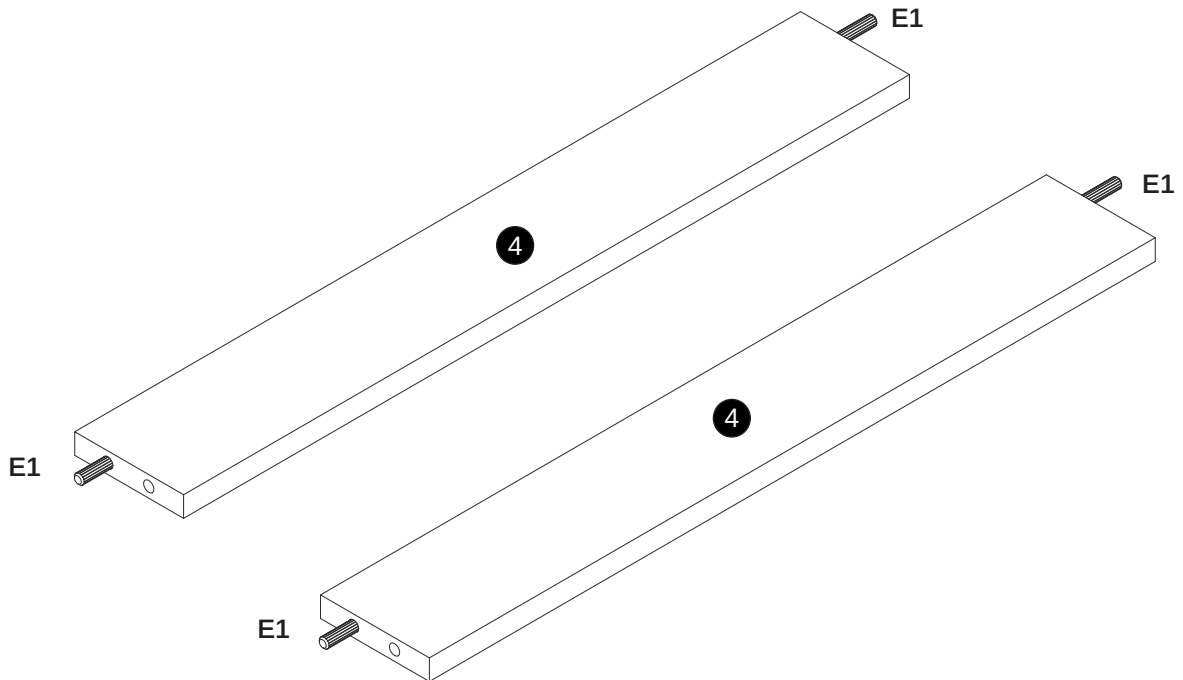

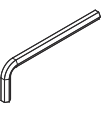
3	F1		K2	
		4x		1x

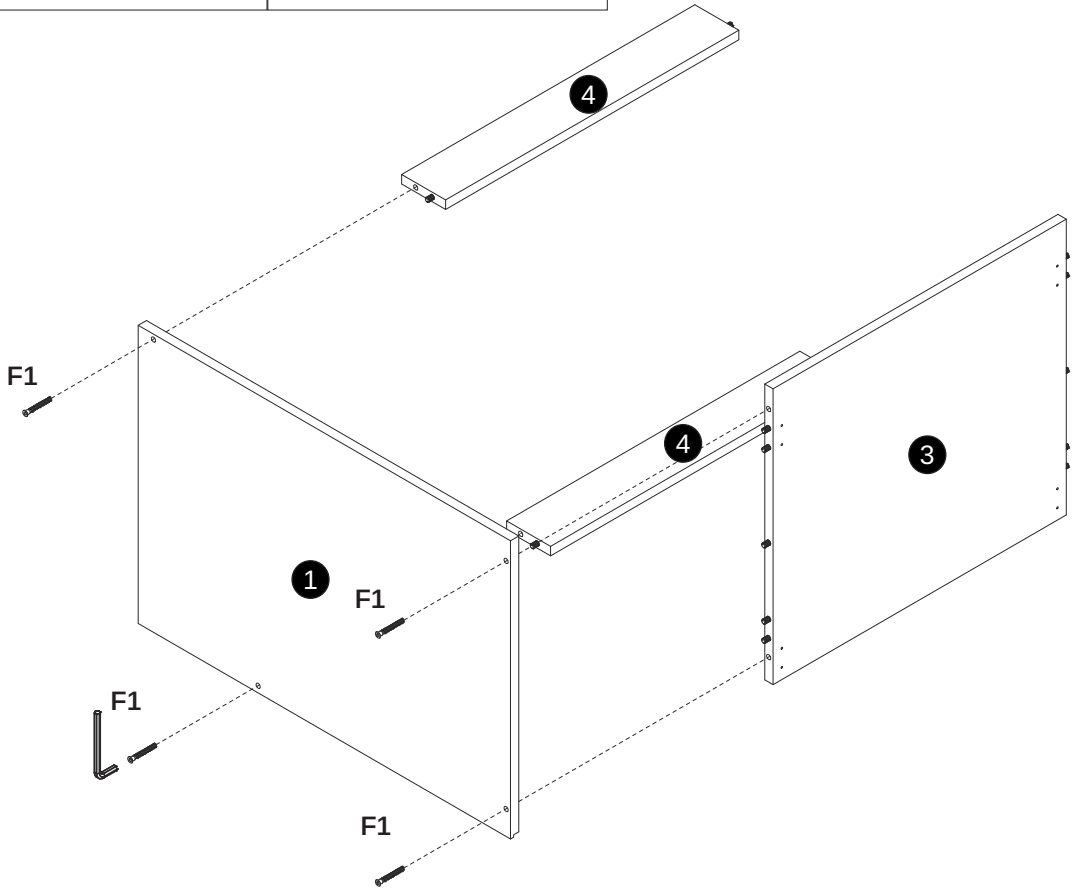

4

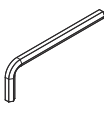
F1		K2	
	4x		1x

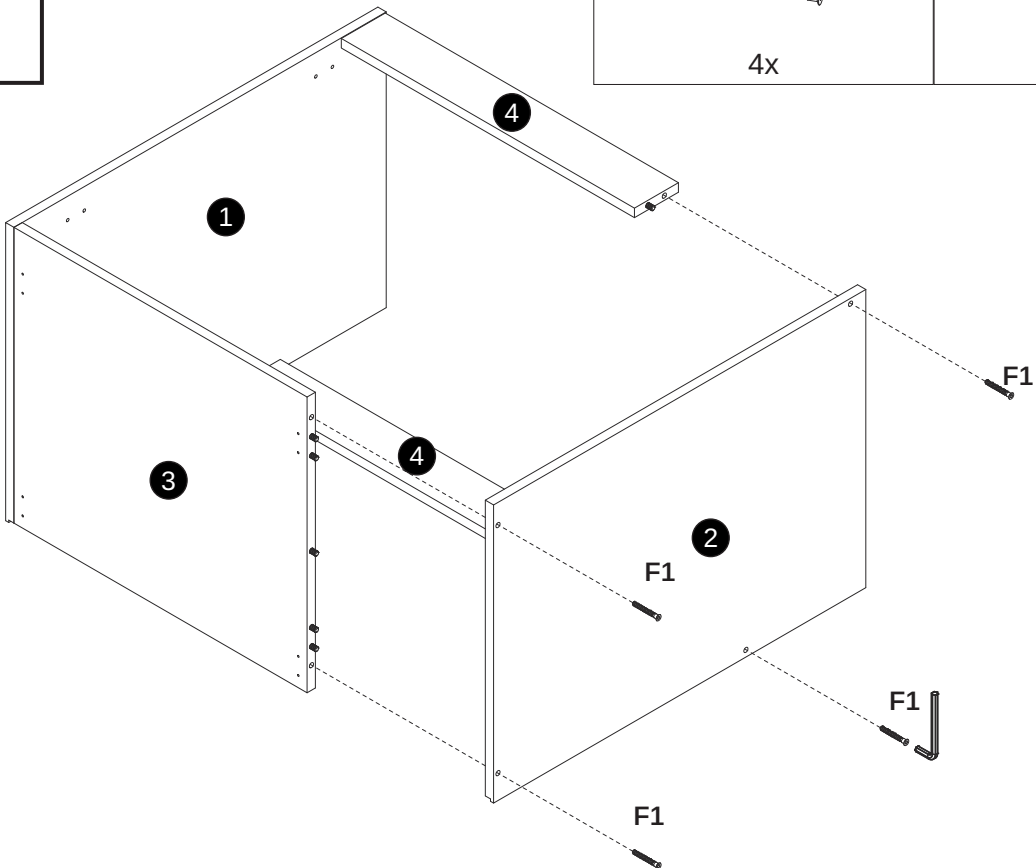

7

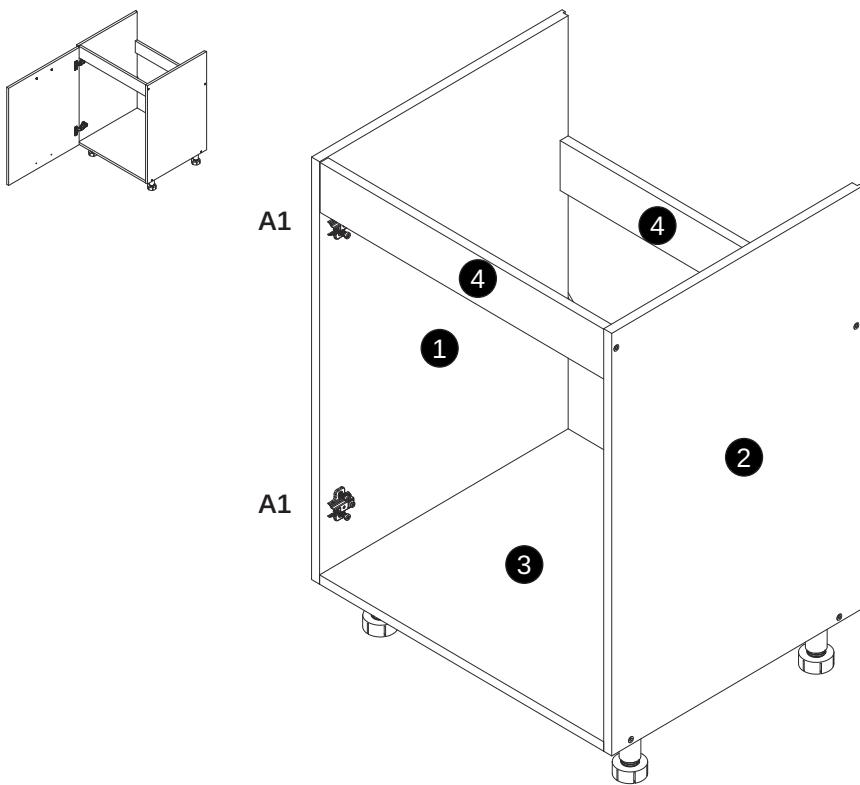
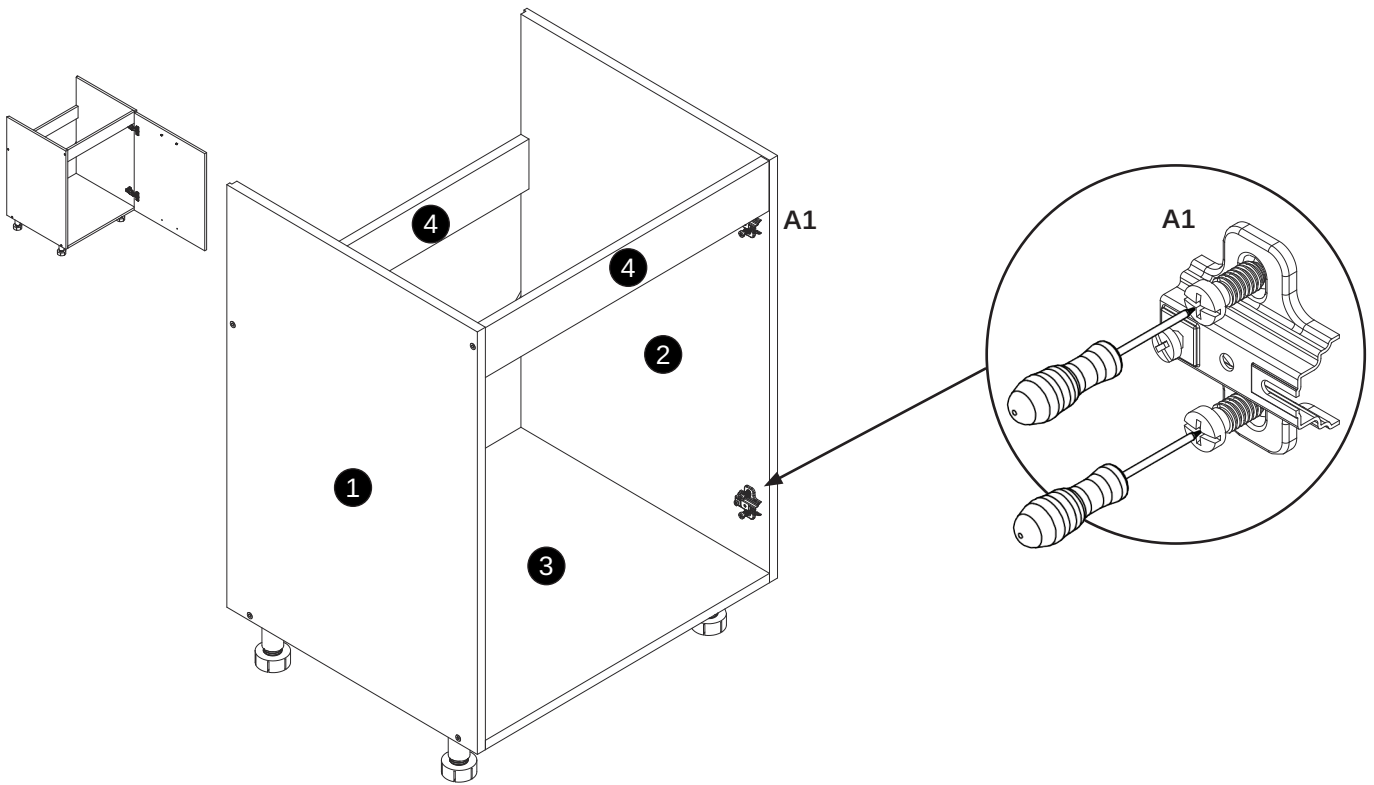
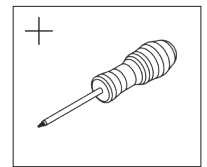
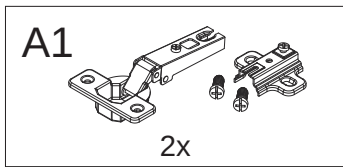

8



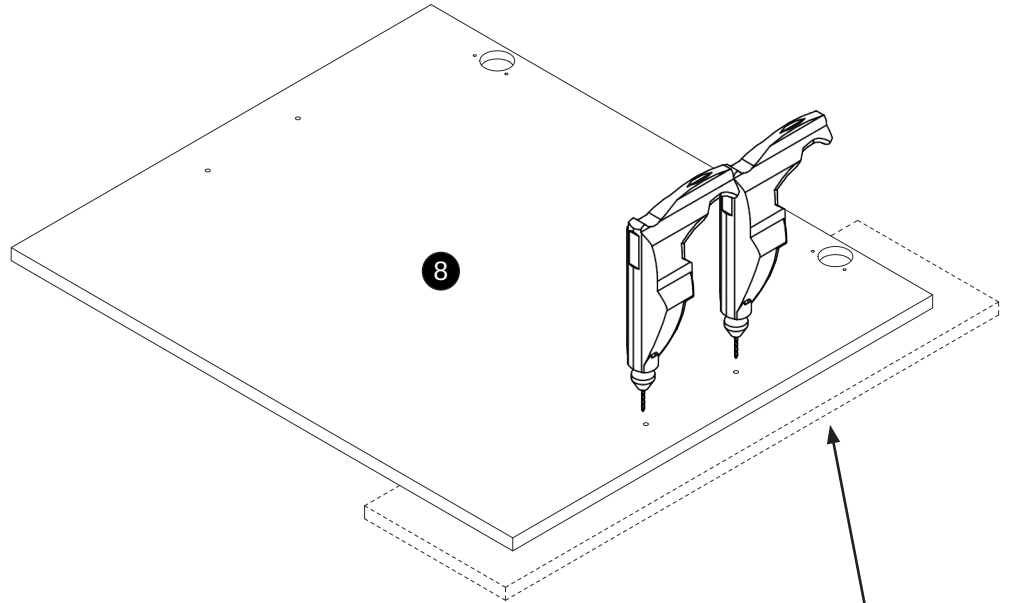
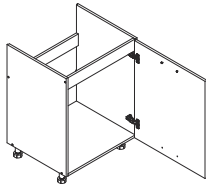
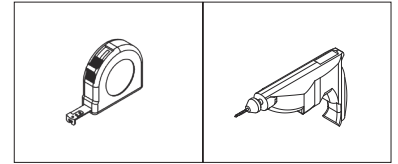
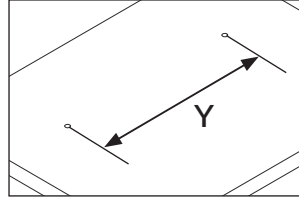
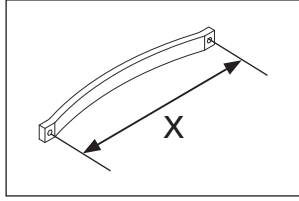

! X=Y

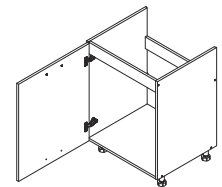
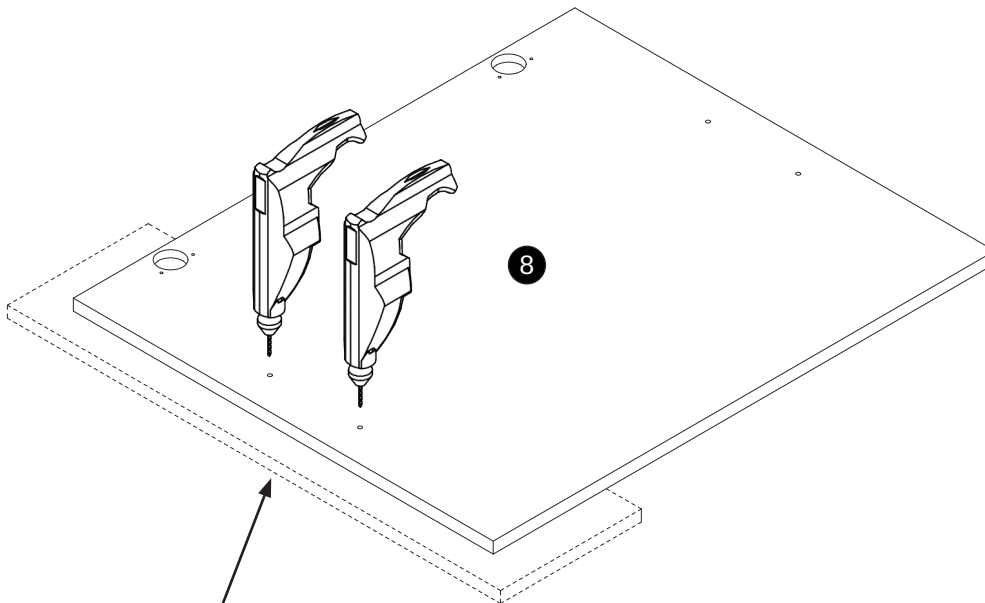

Użyj podkładki !!!
Use a washer !!!
Verwenden Sie eine Montageplatte !!!
Utilisez un tapis !!!

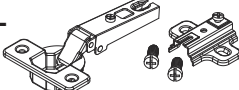

Użyj podkładki !!!
Use a washer !!!
Verwenden Sie eine Montageplatte !!!
Utilisez un tapis !!!

9	U1  1x	P9  2x	A1  2x	
	S1c  4x			

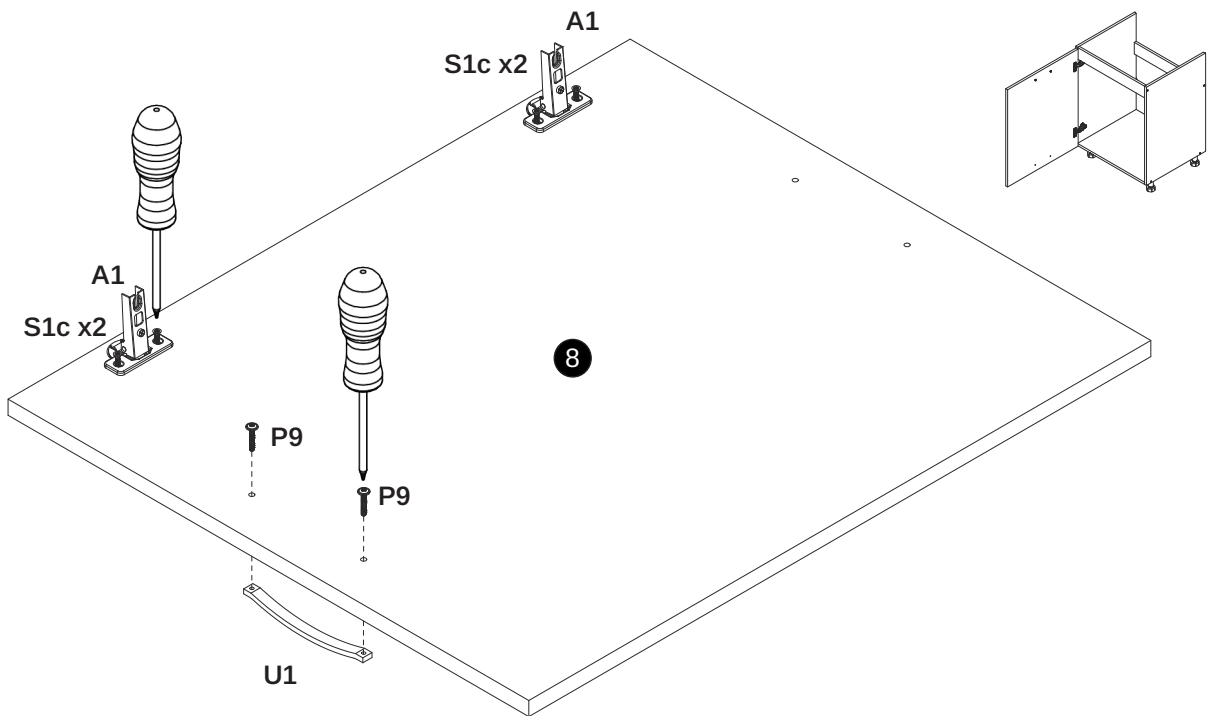
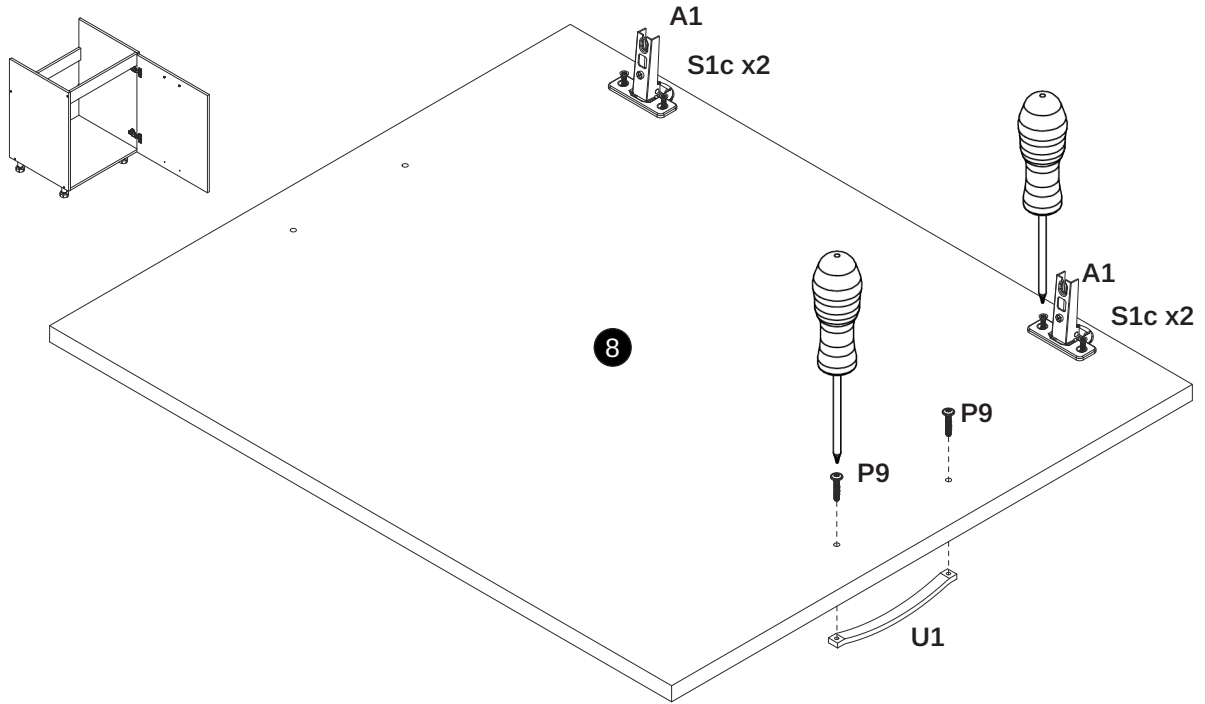

10

D11
x2



F10
x8

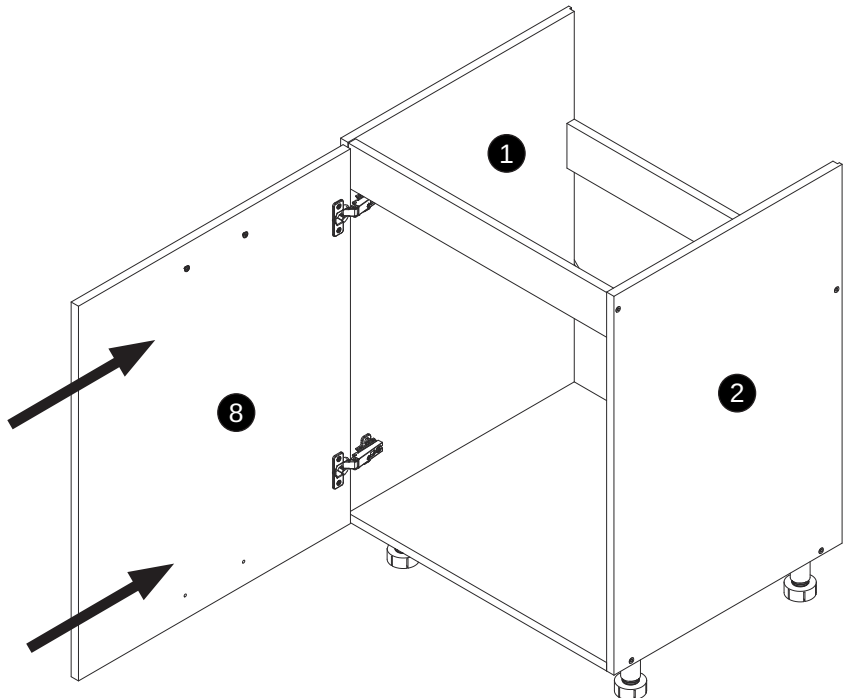
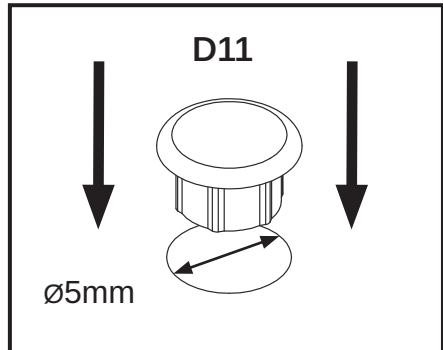
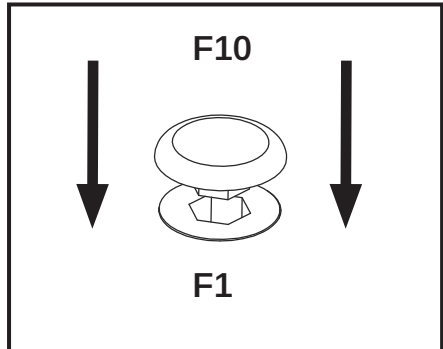
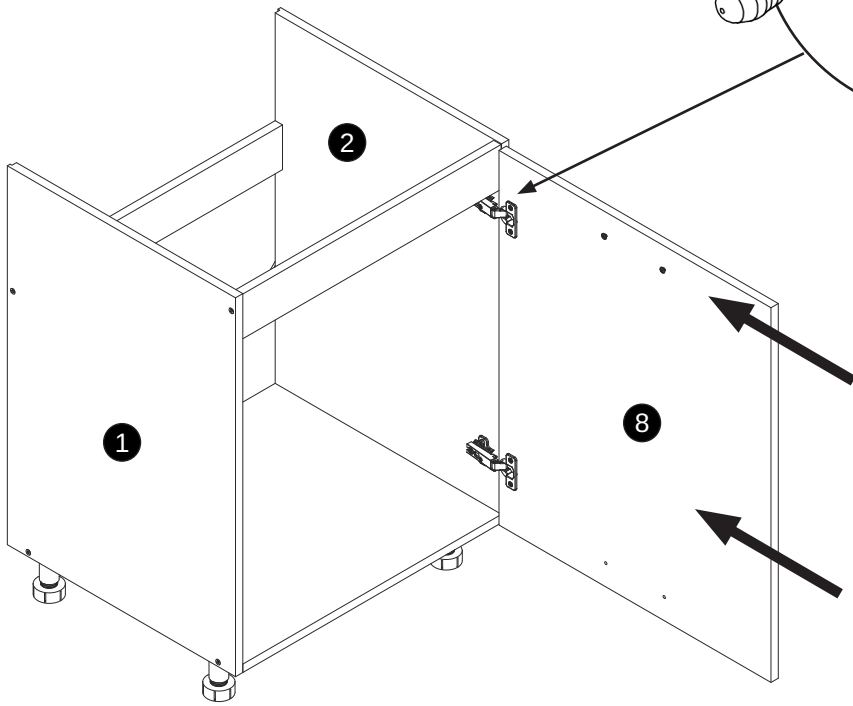
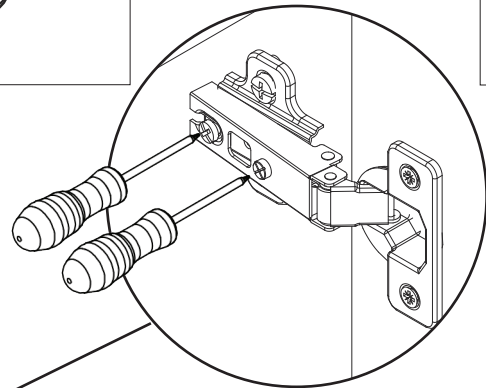
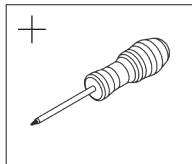

11

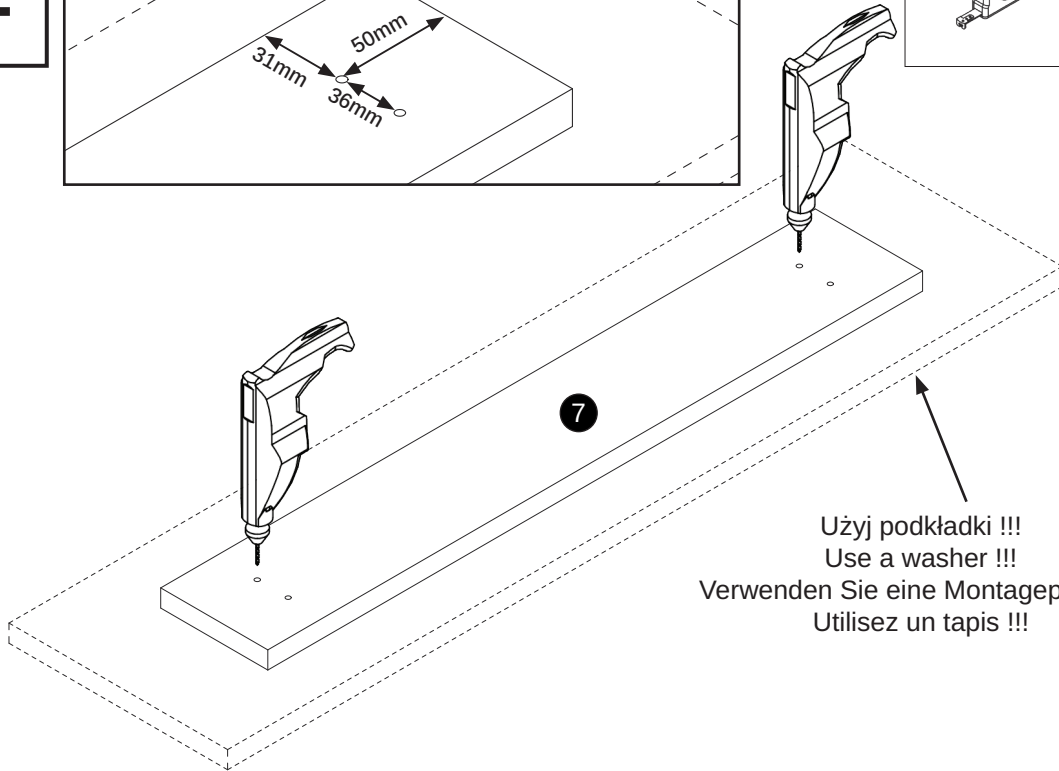
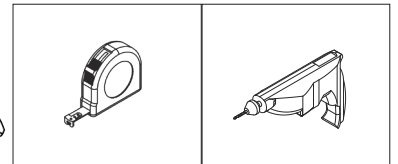
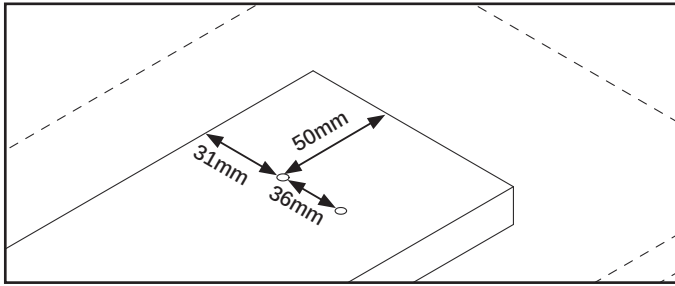

Użyj podkładki !!!
Use a washer !!!
Verwenden Sie eine Montageplatte !!!
Utilisez un tapis !!!

12

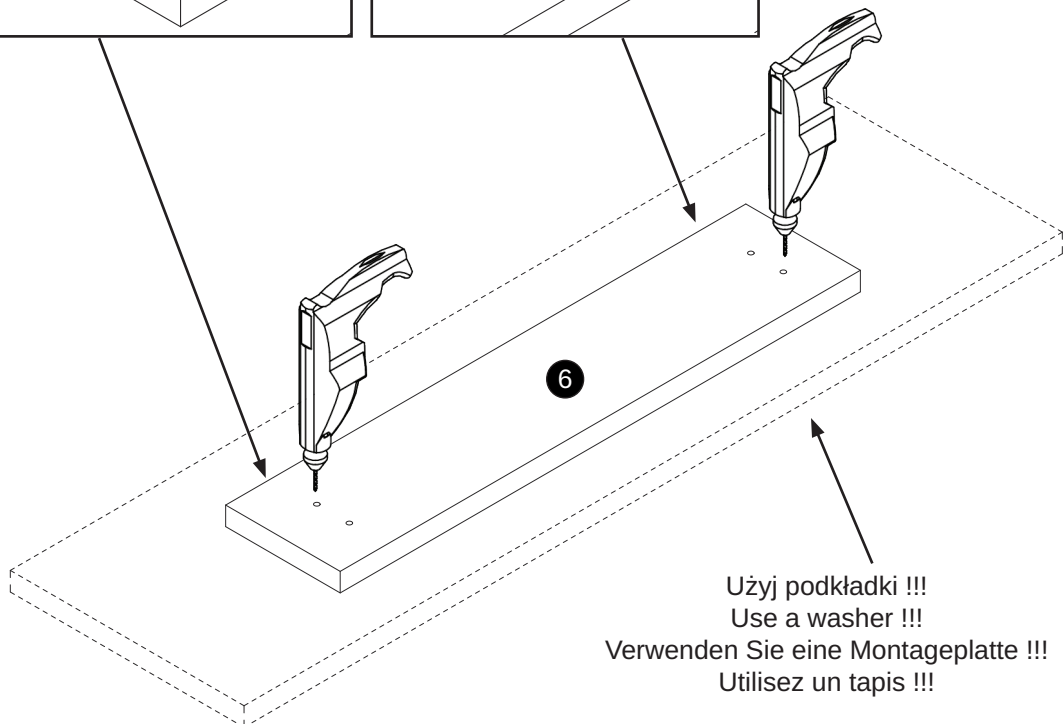
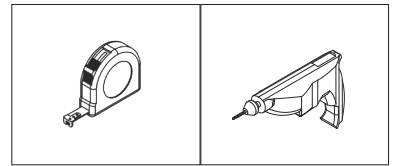
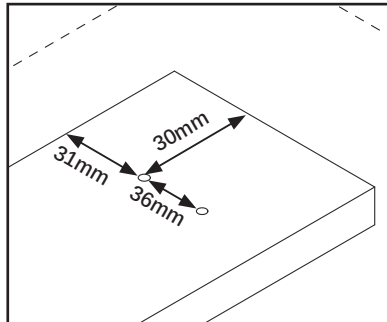
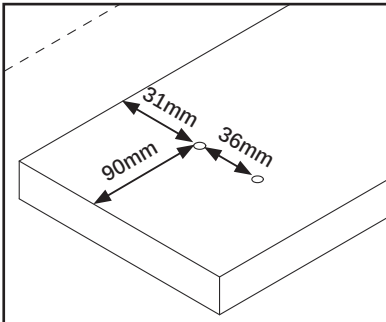

Użyj podkładki !!!
Use a washer !!!
Verwenden Sie eine Montageplatte !!!
Utilisez un tapis !!!

13

U6  2x

S1c  4x

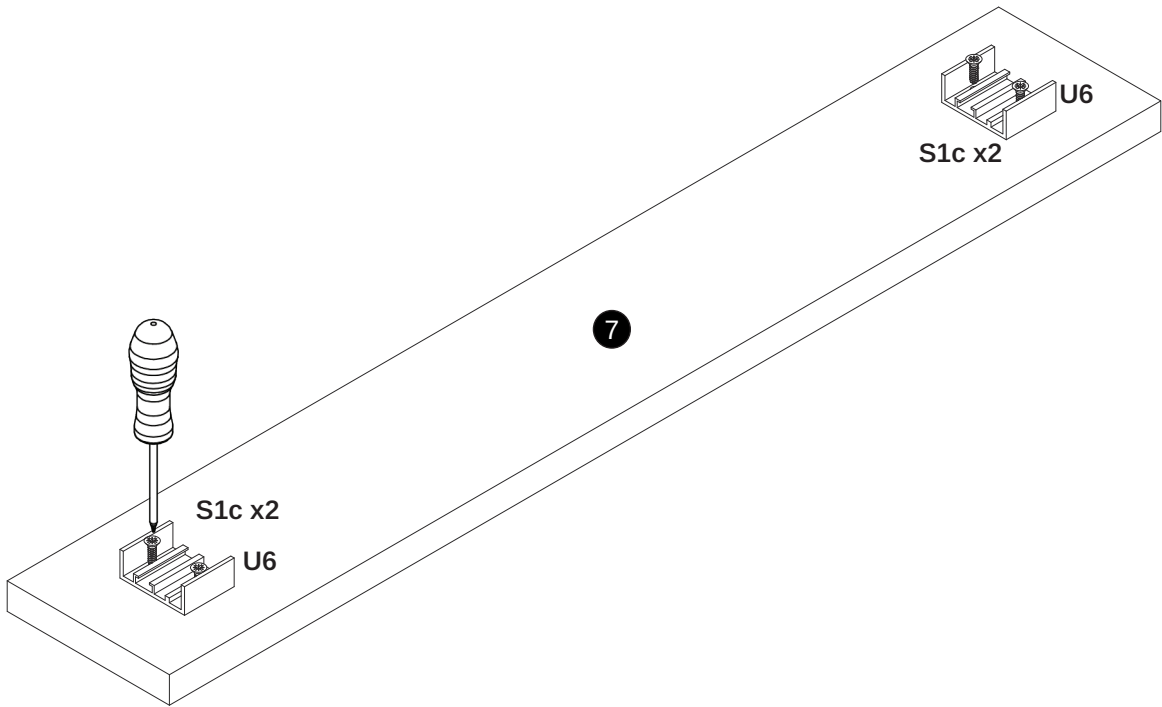
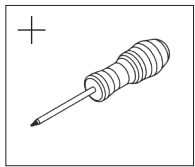

14

U6  2x

S1c  4x

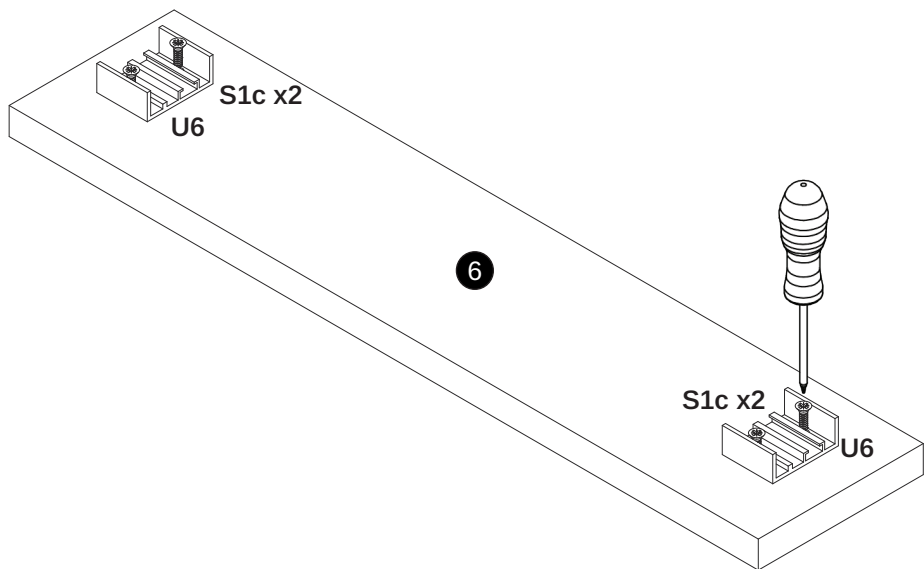
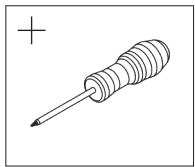

15

R1
2x

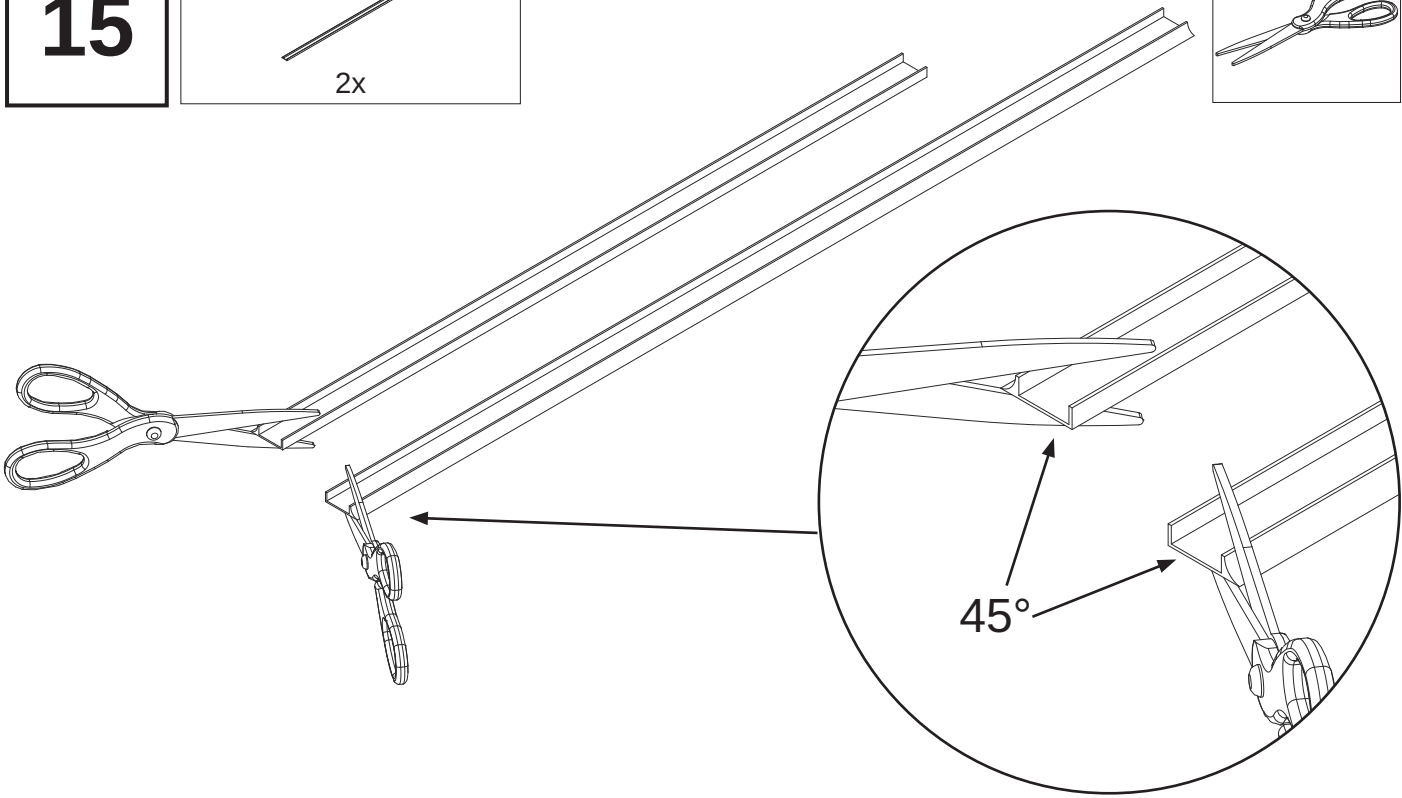
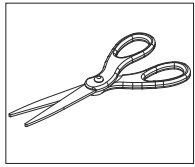

16

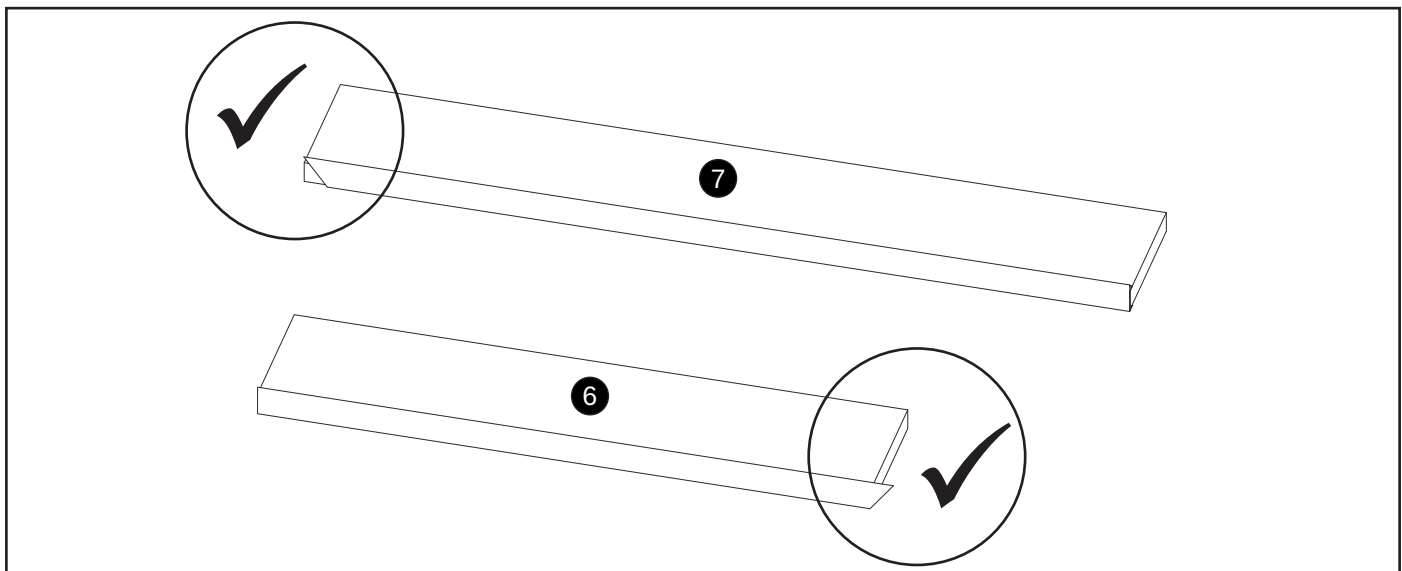
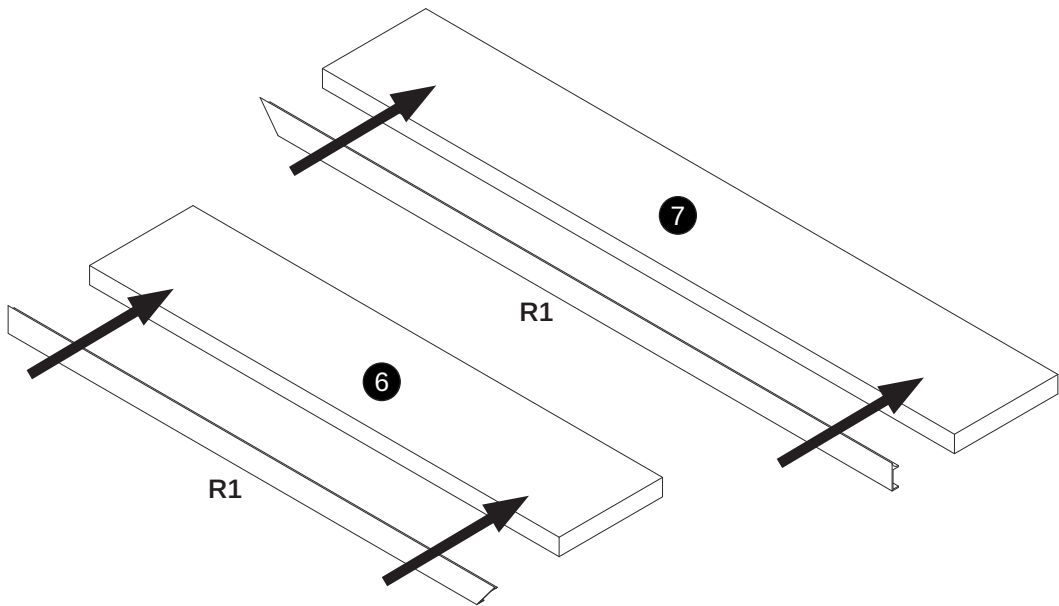

17

U7
4x

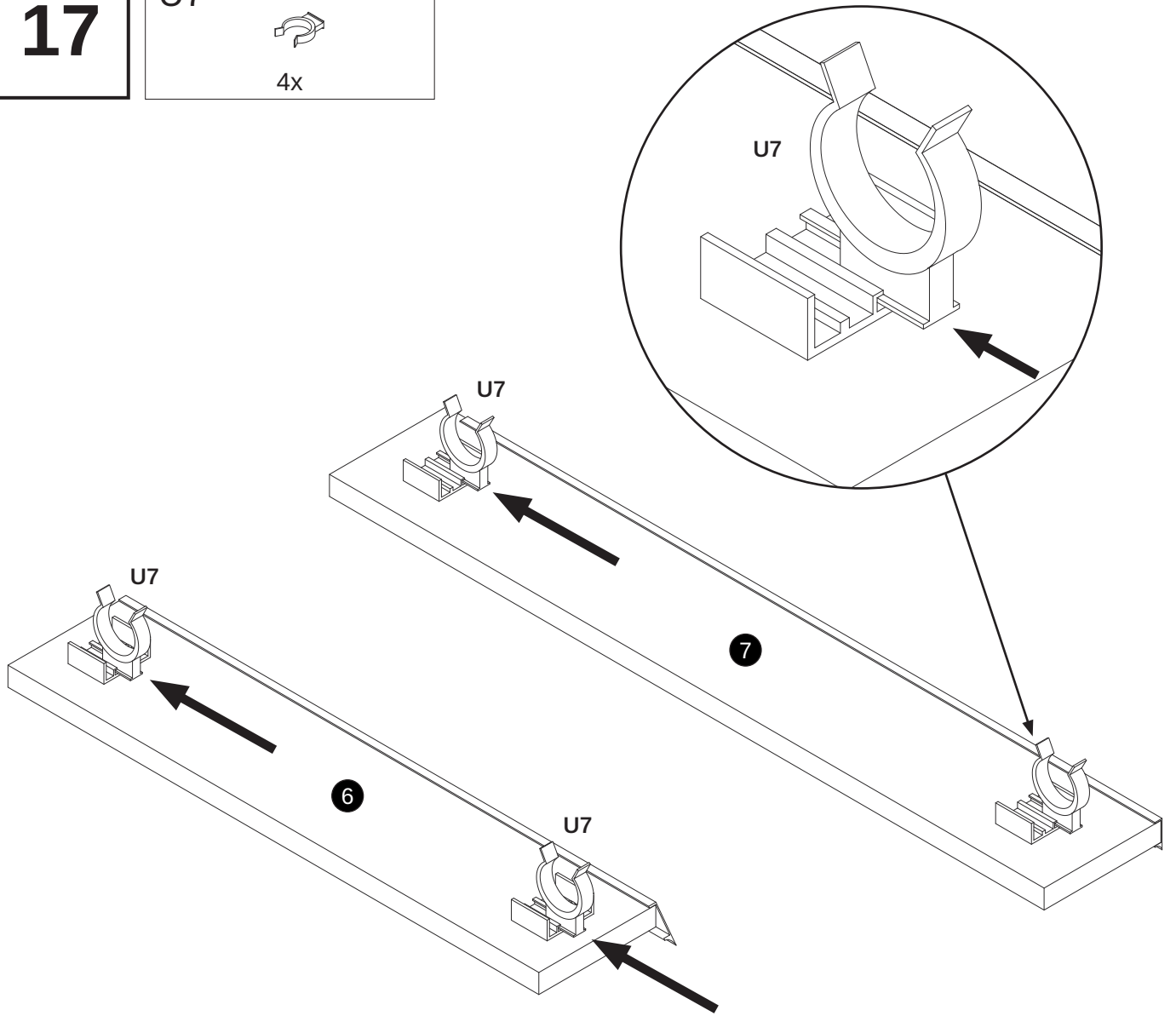

18

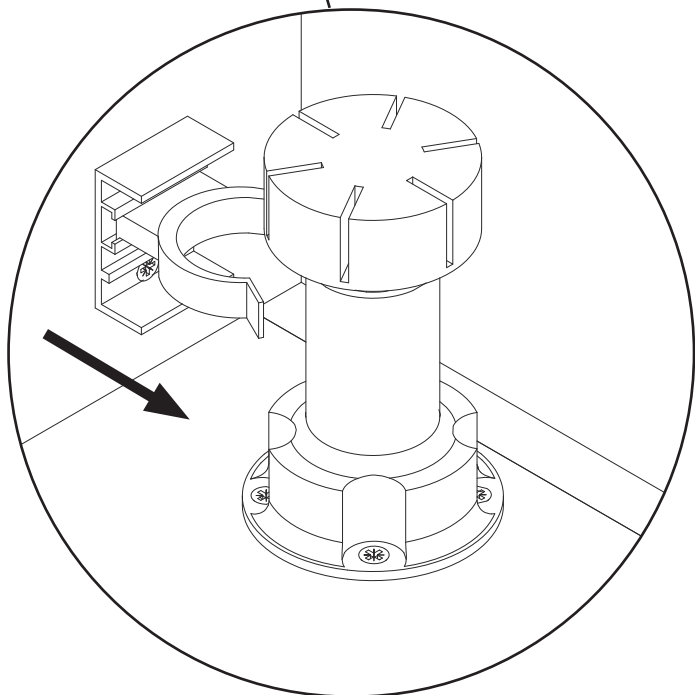
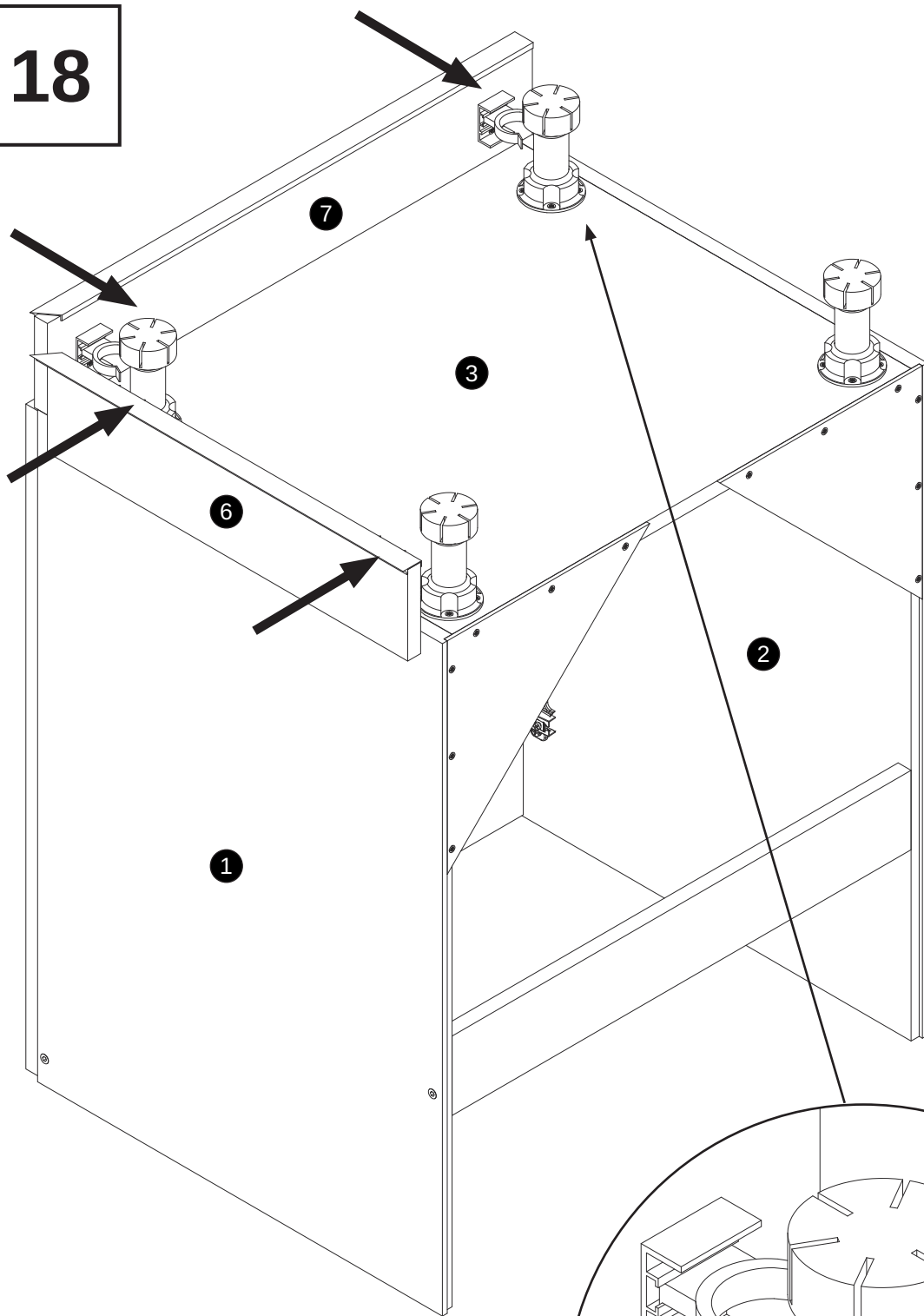

19

D13
4x



S1c
4x

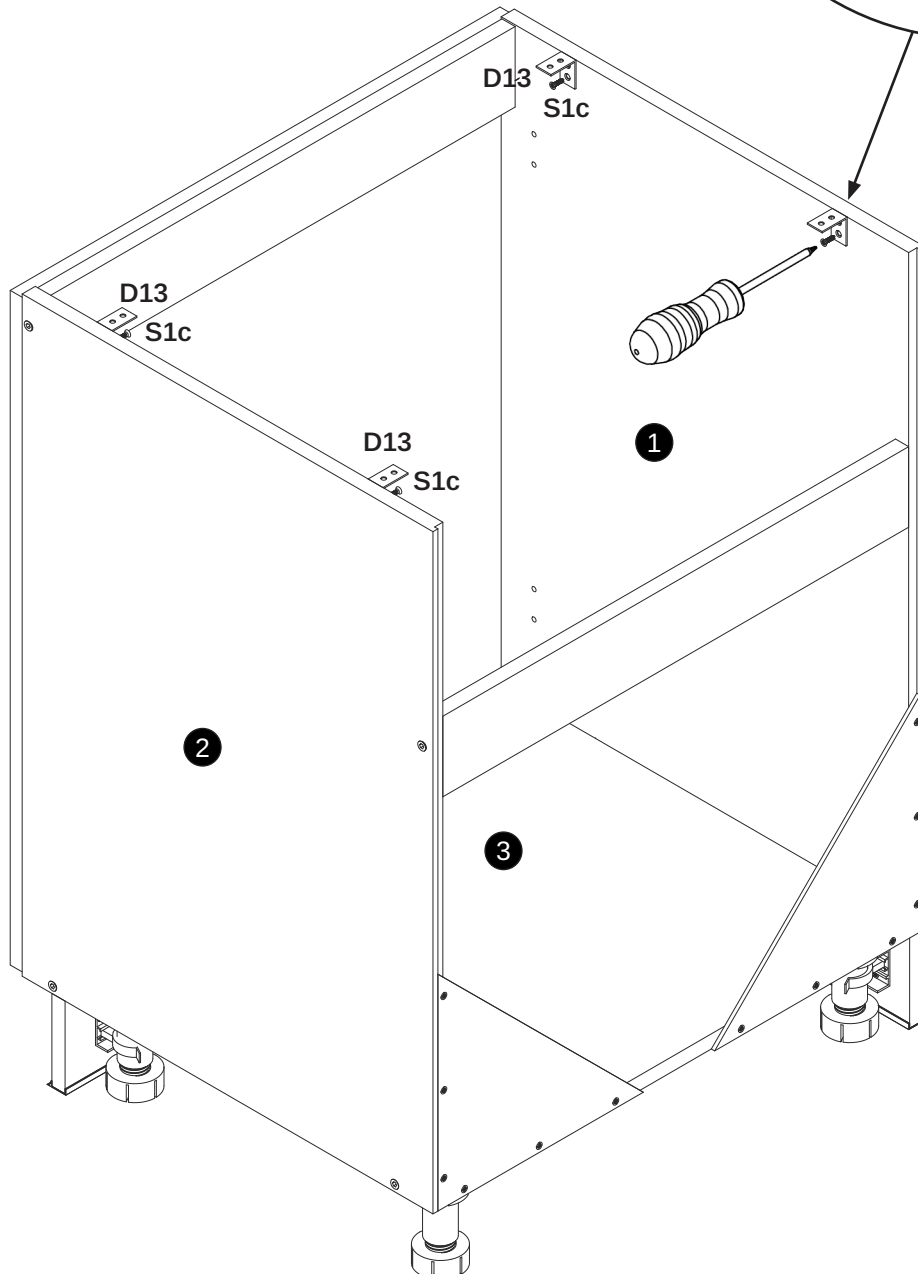
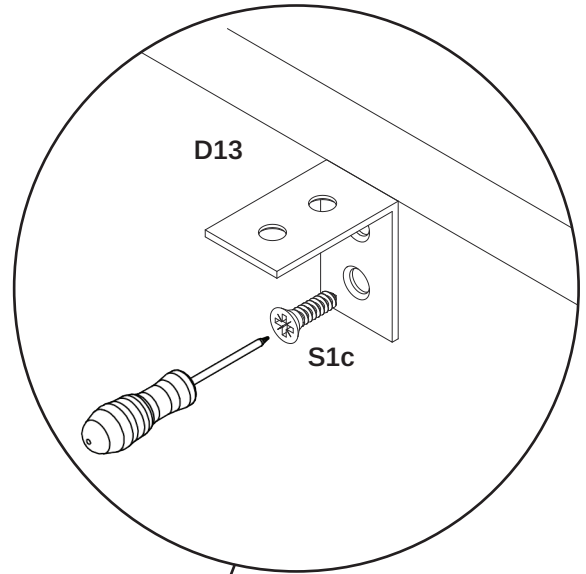
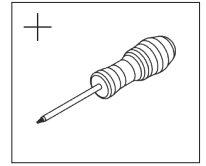

20

S1c
4x

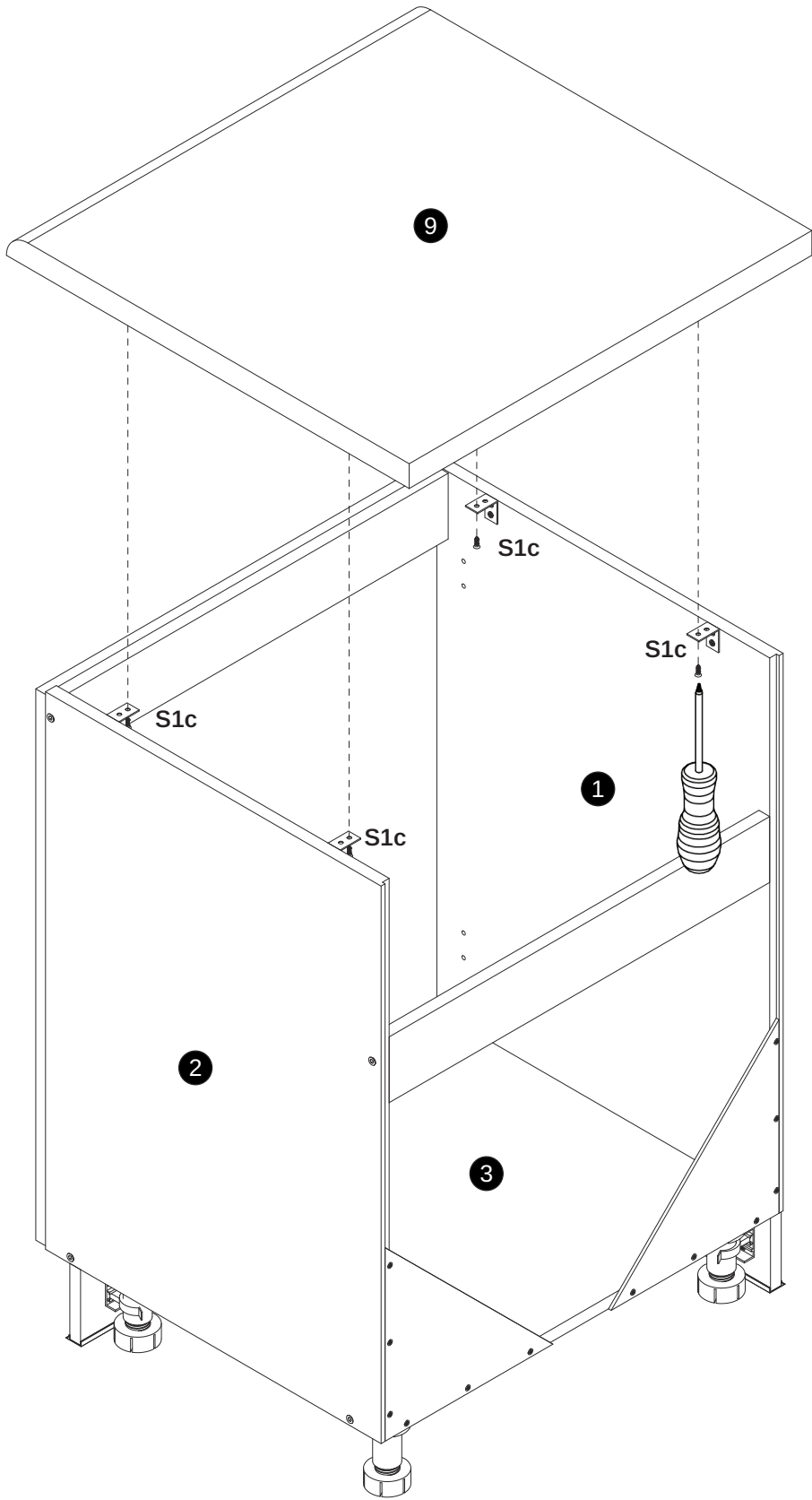
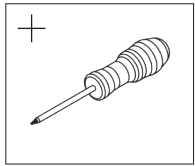

21

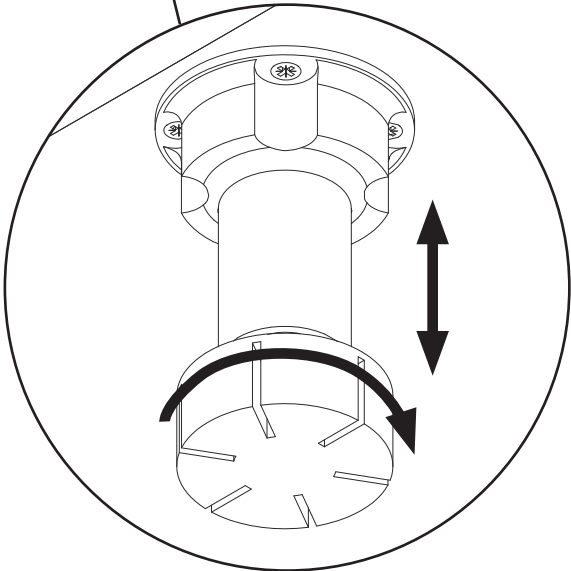
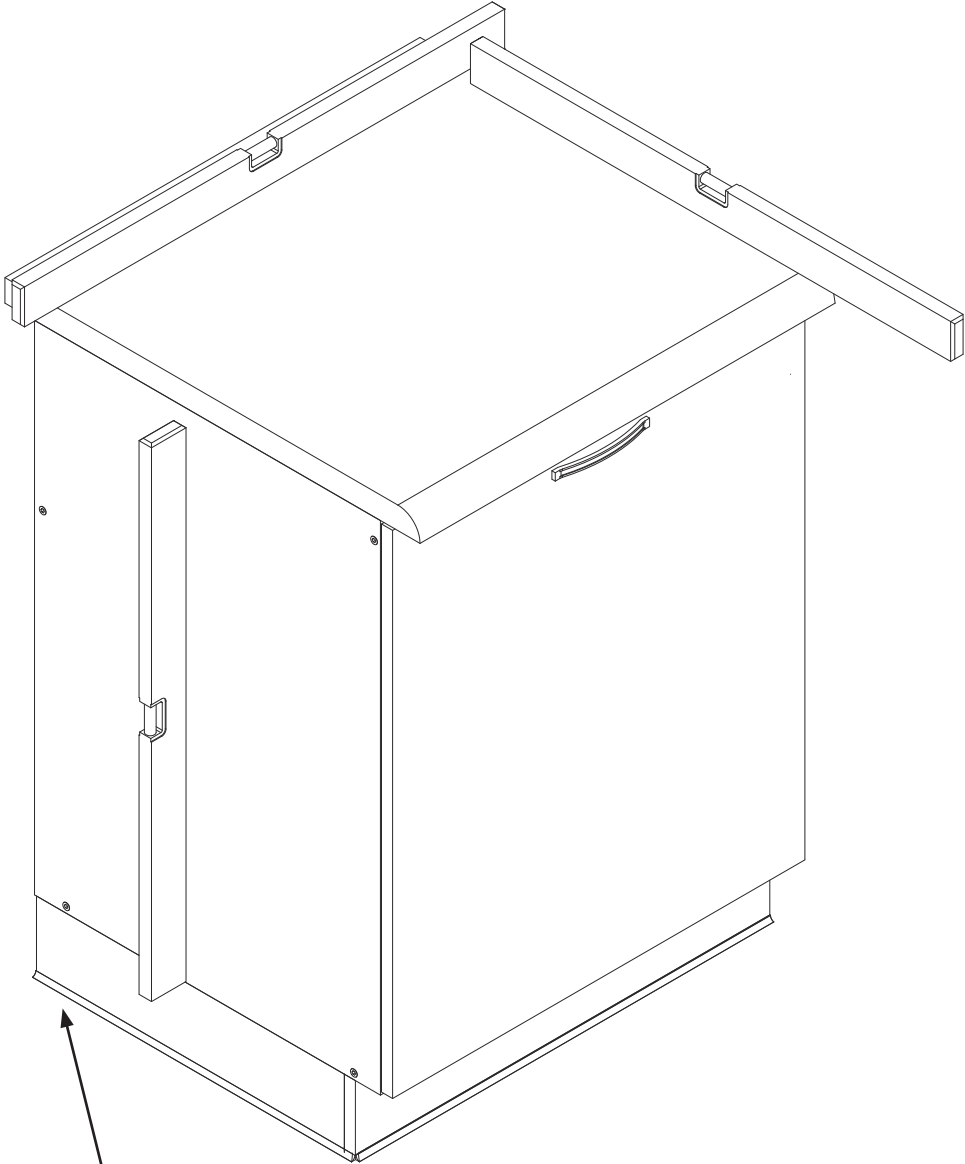
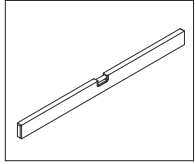

22*

B1 
1x

S1c 
4x

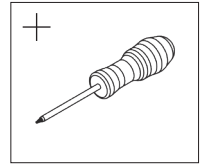

*
Opcjonalnie !
Optionally !
Optional !
En option !

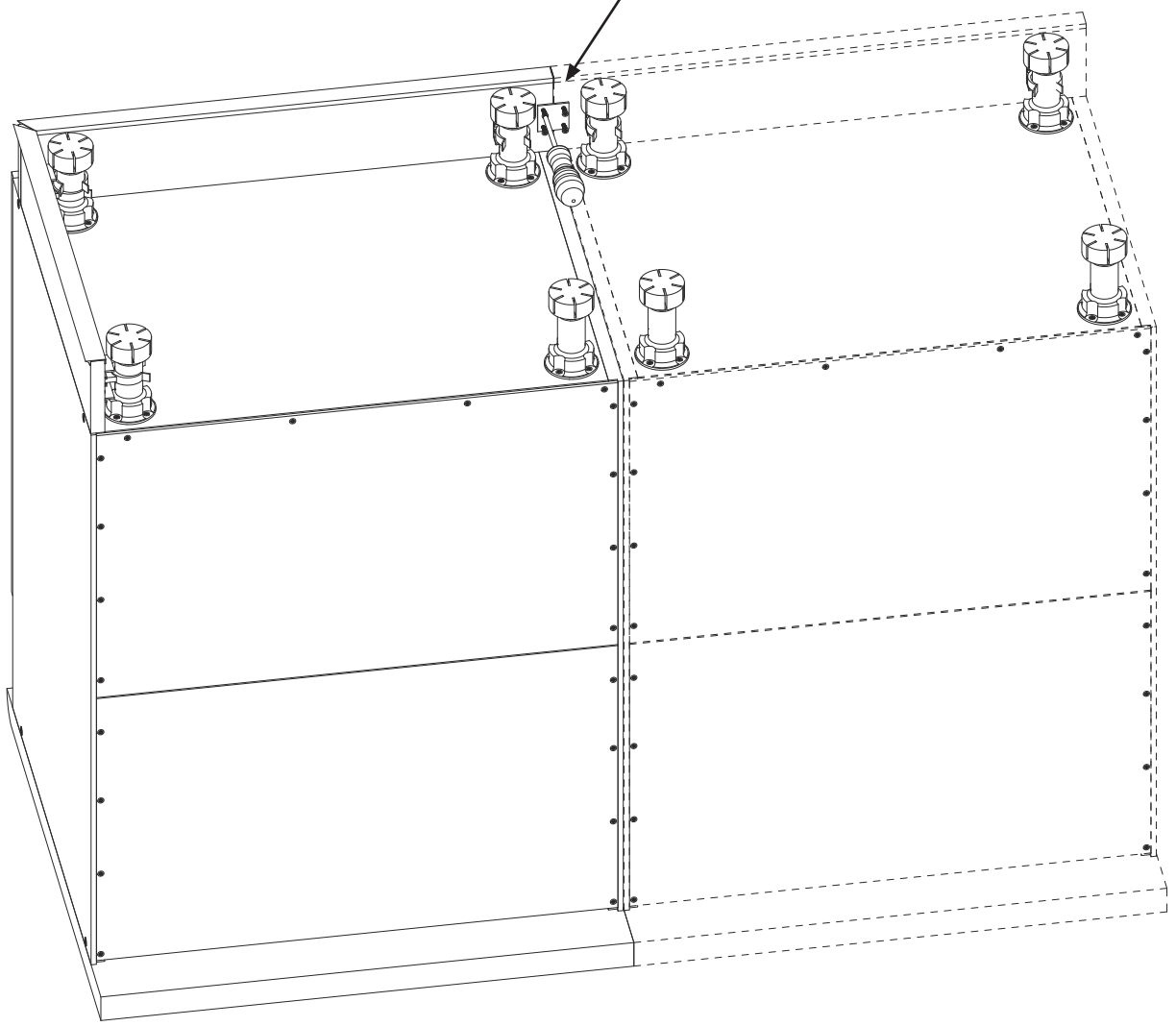
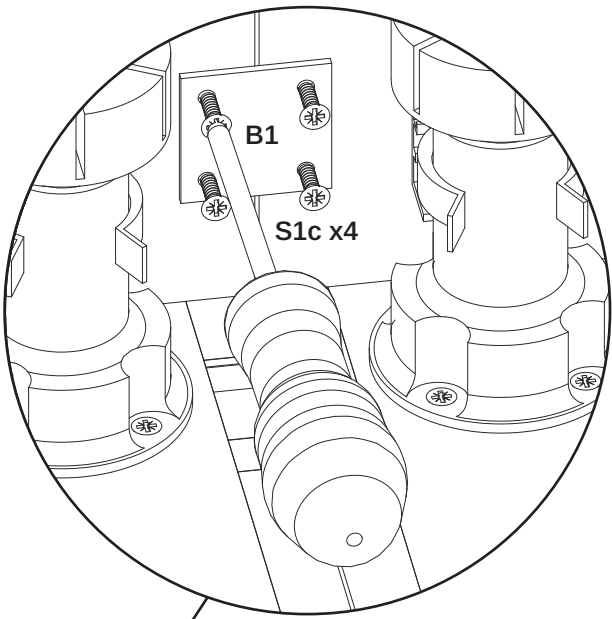

Zasady użytkowania i konserwacji mebli

PL

- Meble należy użytkować w pomieszczeniach suchych, ogrzewanych zabezpieczonych przed szkodliwymi wpływami atmosferycznymi.
- W trakcie użytkowania mebli należy okresowo sprawdzać stan połączeń technicznych takich jak: mimośrodowy, zawiasy, prowadniki.
- Podczas przenoszenia mebli należy chwycić wyłącznie za pionowe elementy konstrukcyjne takie jak boki, nogi. Bezwzględnie nie można chwycić za elementy poziome, takie jak blaty, półki, szuflady, gdyż grozi to poważnymi uszkodzeniami mebli.
- Powierzchnię mebli należy czyścić wyłącznie środkami przeznaczonymi do pielęgnacji mebli.

EN

- Furniture should be kept in dry places which are heated and protected by harmful influence of atmospheric conditions.
- While the furniture is in use there is a necessity to periodically check the state of the technical connections such as: eccentric rods, hinges, guides.
- While furniture is carried it is necessary to keep only the vertical components, such as sides and legs of the furniture.
- The surface of the furniture should be cleaned only with detergents for furniture care.

DE

- Die Möbel soll man in den trockenen, beheizten und vor den schädlichen Witterungseinflüssen gesicherten Räumen benutzen.
- Im Laufe der Benutzung der Möbel soll man zeitlich den Zustand der technischen Verbindungen wie: Exzenter, Türbänder und Leitstücke prüfen.
- Während des Möbeltransports muss man ausschließlich nach vertikalen Konstruktionselementen wie: Ecken und Beine greifen. Auf keinen Fall darf man nach horizontalen Elementen, wie Blätter, Bretter und Schubladen greifen, was zur ernsthaften Möbelbeschädigung bringen kann.
- Die Fläche der Möbel soll man nur mit dazu geeigneten Pflegemöbelmitteln putzen.

FR

- Les meubles doivent être utilisés dans des pièces sèches, chauffées et protégées contre les effets nocifs de la pollution. Les meubles doivent être utilisés dans des locaux secs, chauffés et protégés des influences atmosphériques nocives.
- Lors de l'utilisation du mobilier, l'état des connexions techniques telles que: excentriques, charnières, guides.
- Lorsque vous déplacez le meuble, ne manipulez que les éléments structurels verticaux, tels que les côtés, jambes. Vous ne devez absolument pas saisir les éléments horizontaux tels que les plateaux, les étagères, les tiroirs, car cela peut provoquer des dommages importants au mobilier.
- La surface du meuble doit être nettoyée uniquement avec des produits destinés à l'entretien des meubles.



Szafka SGp60 (36x60x29,6)

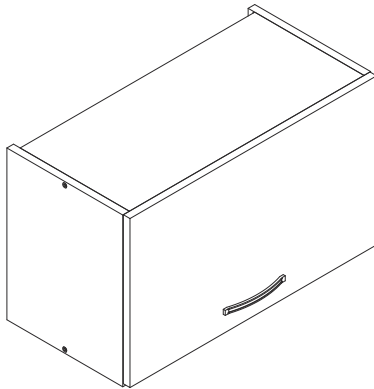

Ilość potrzebnych osób
Number of people needed
Benötigte Personenzahl
Nombre de personnes nécessaires

Niezbędne narzędzia do montażu

Tools necessary for assembly

Notwendiges Werkzeug für die Montage

Outils nécessaires pour le montage

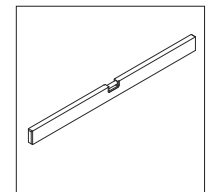
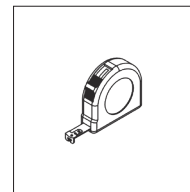
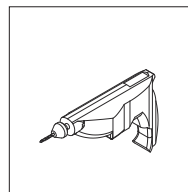
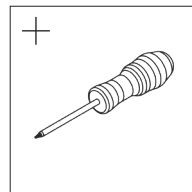

PL

- Przed przystąpieniem do montażu przeczytaj i zapoznaj się z całą instrukcją.
- Przestrzegaj bezwzględnie kolejnych kroków montażowych **1**, **2**, **3**...
- Nie wyrzucaj opakowania dopóki nie ukończysz skutecznie w całości montażu.
- Montaż wykonuj na płaskiej, miękkiej oraz czystej powierzchni takiej jak tektura.
- Bezwzględnie nie montuj elementów jeśli zauważysz ich wady lub uszkodzenia.
- Elementy montażowe takie jak okucia trzymaj w miejscu niedostępnym dla niemowląt i dzieci.
- Wadliwe lub uszkodzone elementy reklamuj podając ich numer z instrukcji montażu.
- Jeśli uszkodzony element będzie zamontowany reklamacja nie będzie uznana.

EN

- Read and get familiar with the whole instruction before the process of installation.
- Imperatively observe the consecutive assembly steps **1**, **2**, **3**...
- Do not throw away the packaging until the installation is successfully done.
- The installation should be done on the flat, soft and clear surface, such as cardboard.
- Under no circumstances should you install the elements in case of any faults or damage.
- The installation elements as fittings should be kept in a place unavailable for babies or children.
- Faulty or damaged components should be complaint by giving the number of the assembly instruction.
- If the damaged component is installed, the complaint will not be accepted.

DE

- Vor Beginn der Montage muss man die Instruktion genau durchlesen.
- Die aufeinanderfolgenden Montageschritte **1**, **2**, **3**... unbedingt beachten.
- Man muss die Packung behalten bis man die ganze Montage erfolgreich nicht beendet.
- Die Montage muss man auf einer glatten, weichen und sauberen Fläche ausüben
- Fehlerhafte oder beschädigte Elemente darf man auf keinen Fall montieren. Auf keinen Fall darf man fehlerhafte oder beschädigte Elemente montieren.
- Die Montageelemente wie Beschläge muss man unzugänglich von Babys und Kindern halten.
- Fehlerhafte oder beschädigte Elemente muss man nur mit Nummer der Instruktion reklamieren.
- Falls das beschädigte Element montiert wird, wird die Reklamation nicht berücksichtigt.







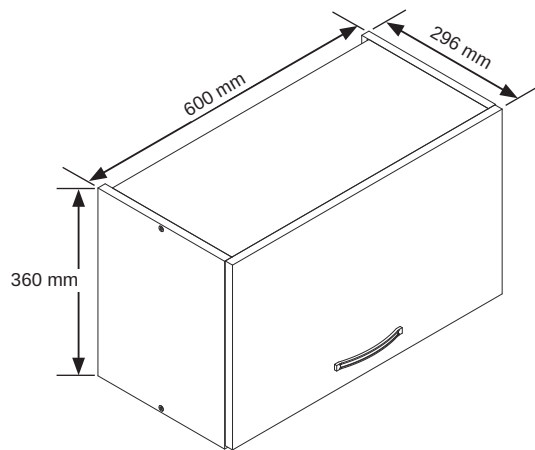

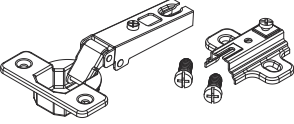
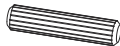

FR

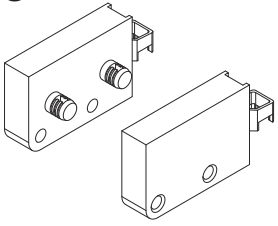
- Avant de commencer le montage, lire et prendre connaissance de l'intégralité du manuel.
- Respectez scrupuleusement les étapes d'installation suivantes **1**, **2**, **3**...
- Ne pas jeter l'emballage avant d'avoir terminé l'assemblage.
- Le montage doit être effectué sur une surface plane, souple et propre, comme du carton.
- Ne pas assembler si vous remarquez des défauts ou des dommages.
- Garder les éléments de montage tels que les raccords hors de portée des bébés et des enfants.
- Réclamer les pièces défectueuses ou endommagées en citant le numéro figurant dans les instructions de montage.
- Si l'article endommagé est installé, la plainte ne sera pas acceptée.

SZAFKA SGp60

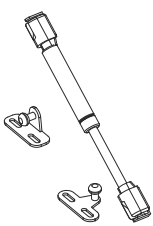
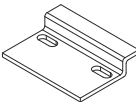

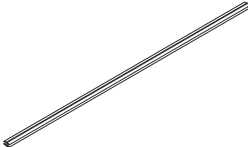
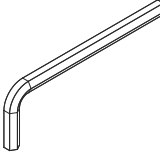
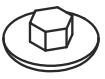

Okucia / Fittings / Beschläge / Embouts

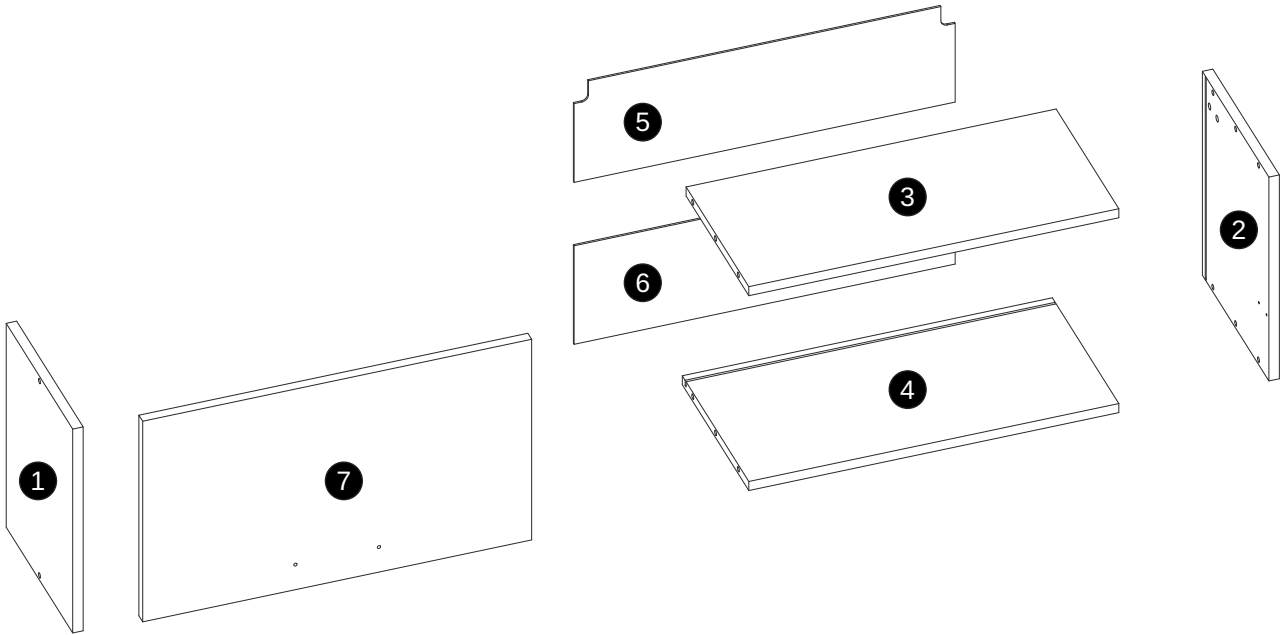
				S1a  3,5x13mm x4
A1  x2	E1  x8	D15  x7	D3  x2	
S1b  3,5x29mm x4	S1c  3,5x16mm x4	P9  4x27mm x2	U1  x1	
V3  x1	D2  x2	F1  7x50mm x4	D11  x2	
S0b  3x16mm x5	H1  x1	K2  x1	F10  x4	

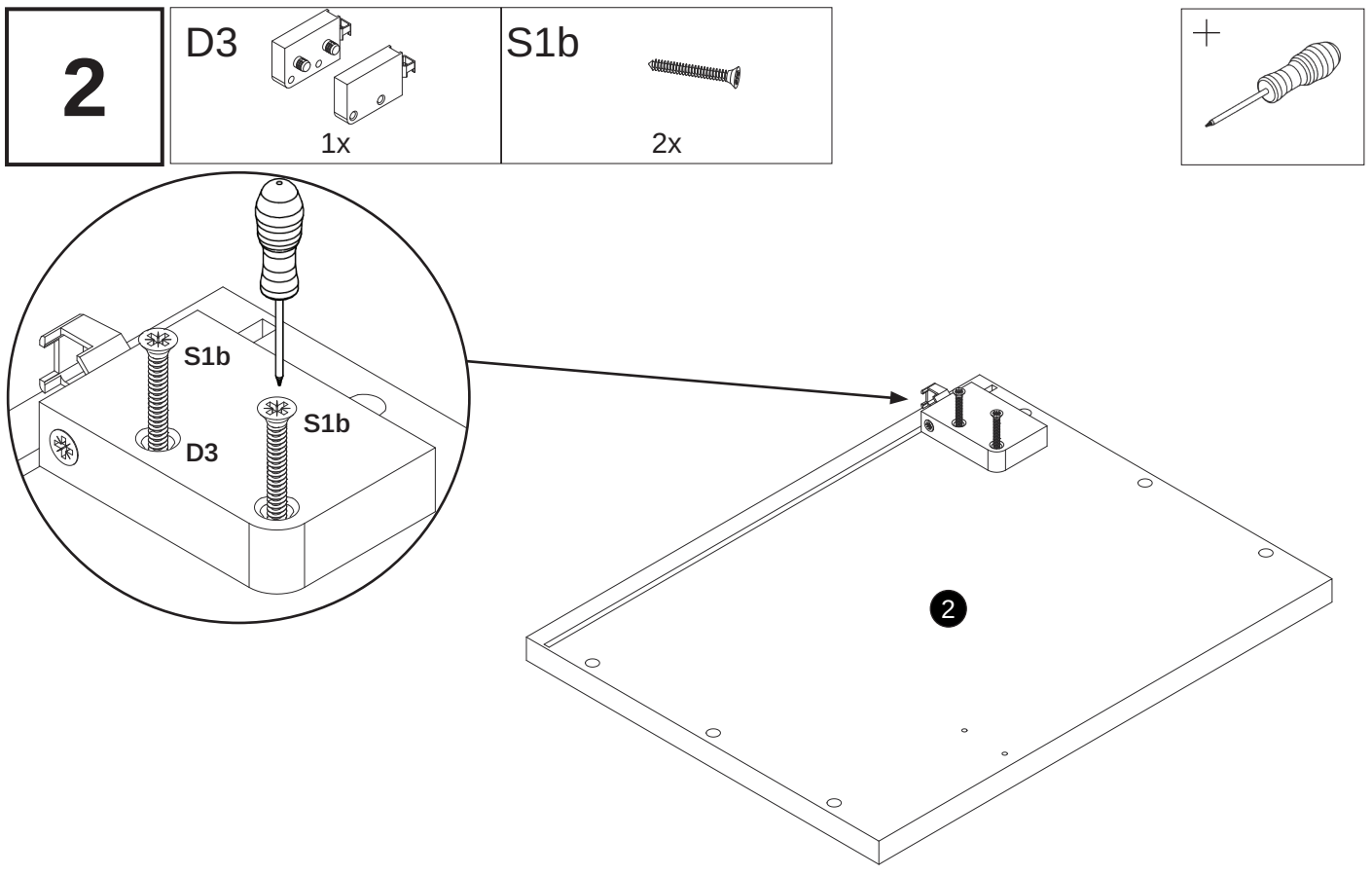
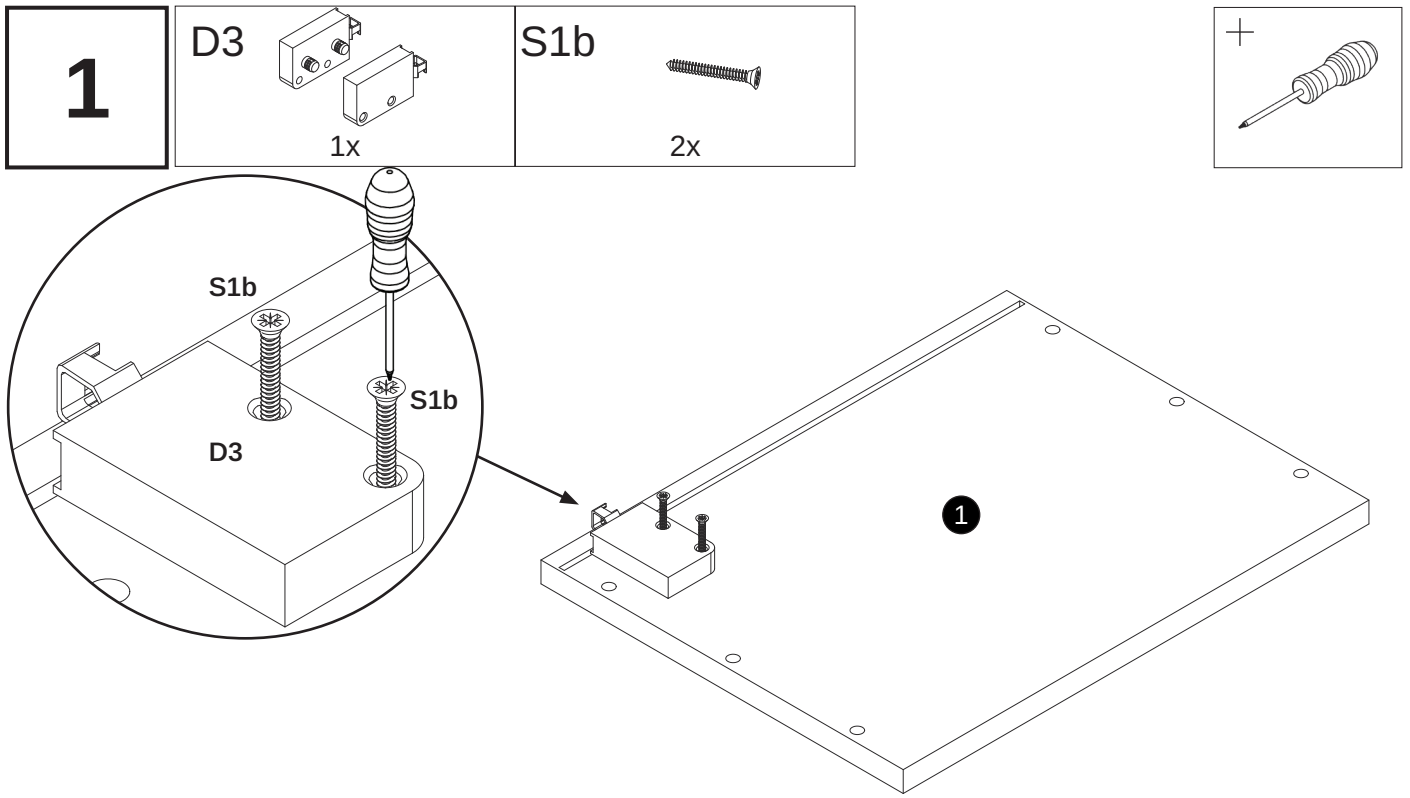

SGp60	
①	1x (360x280mm)
②	1x (360x280mm)
③	1x (567x264mm)
④	1x (567x280mm)
⑤	1x (584x177mm)
⑥	1x (584x177mm)
⑦	1x (596x356mm)



3	E1 
	4x

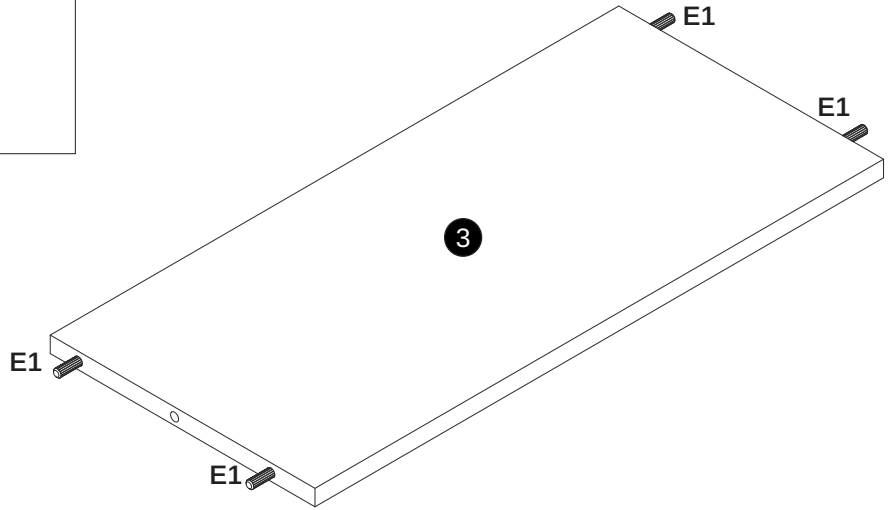

4	E1 
	4x

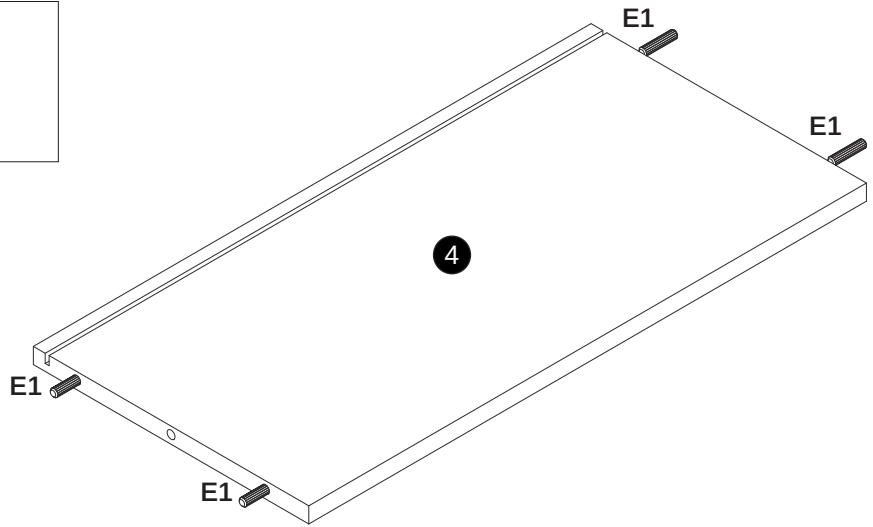

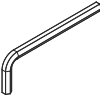
5	F1 	K2 
	2x	1x

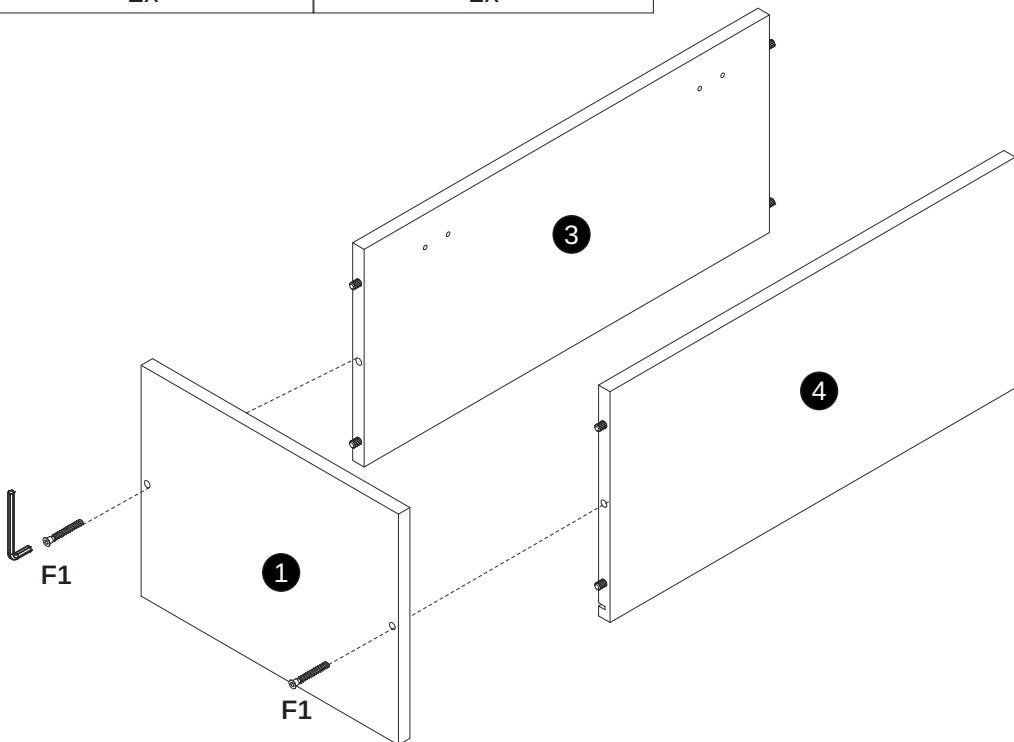

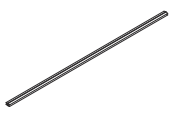

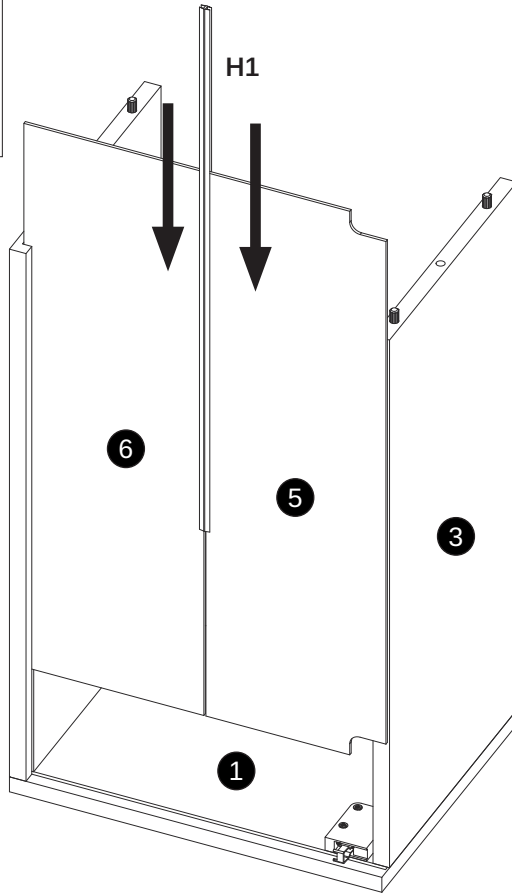

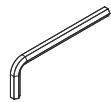
6	H1  1x
----------	---

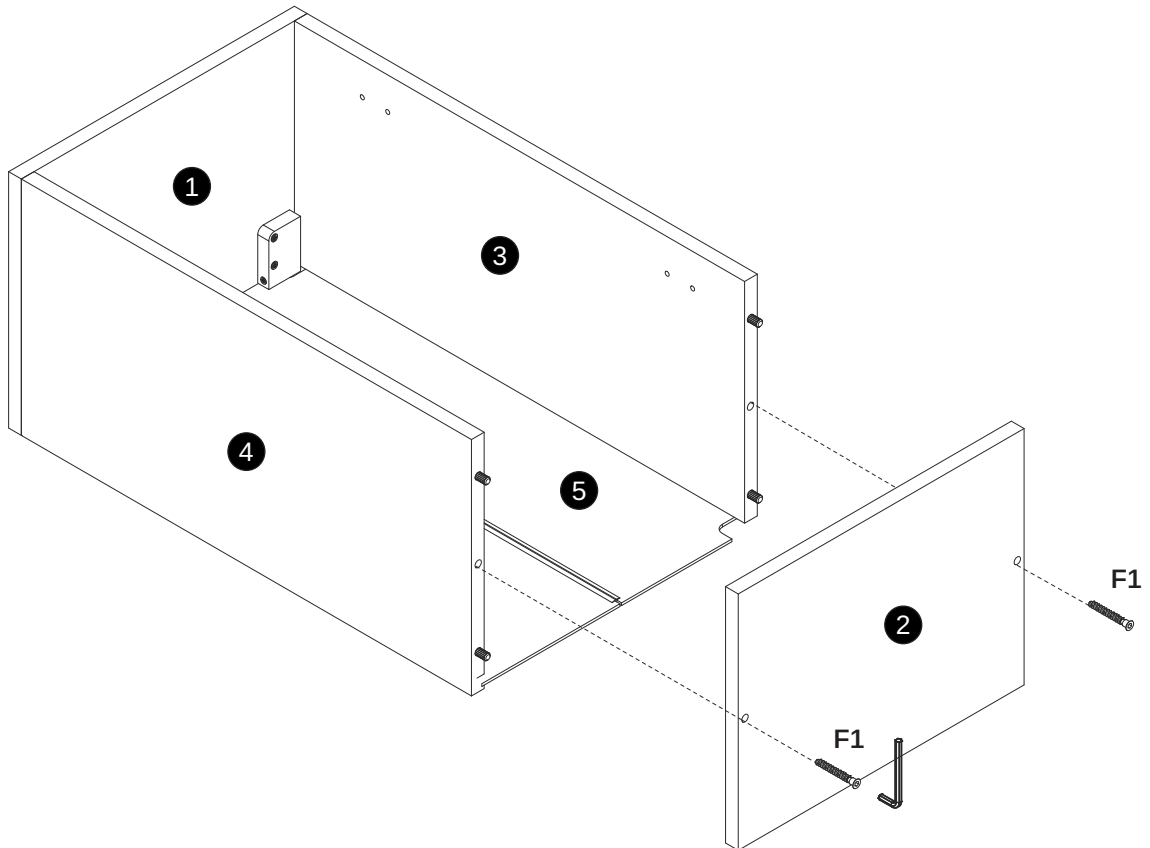

7	F1  2x	K2  1x
----------	---	---



8	D15		S0b	
		7x		

	
---	---

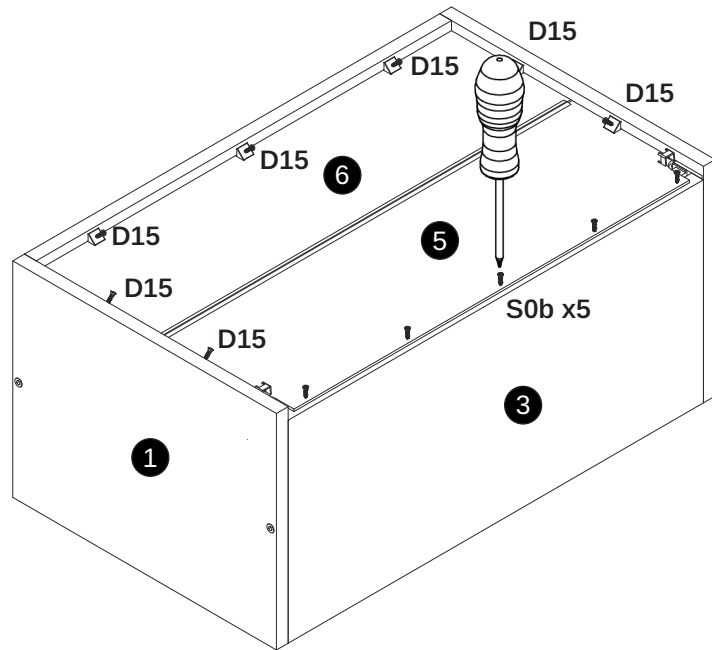
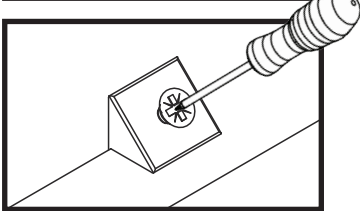
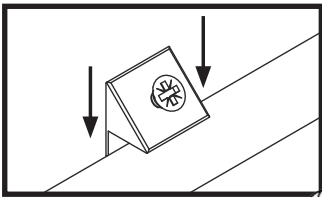
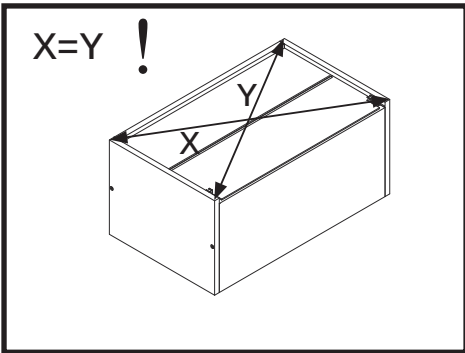

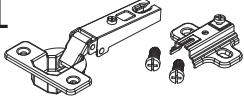
9	A1	
		2x



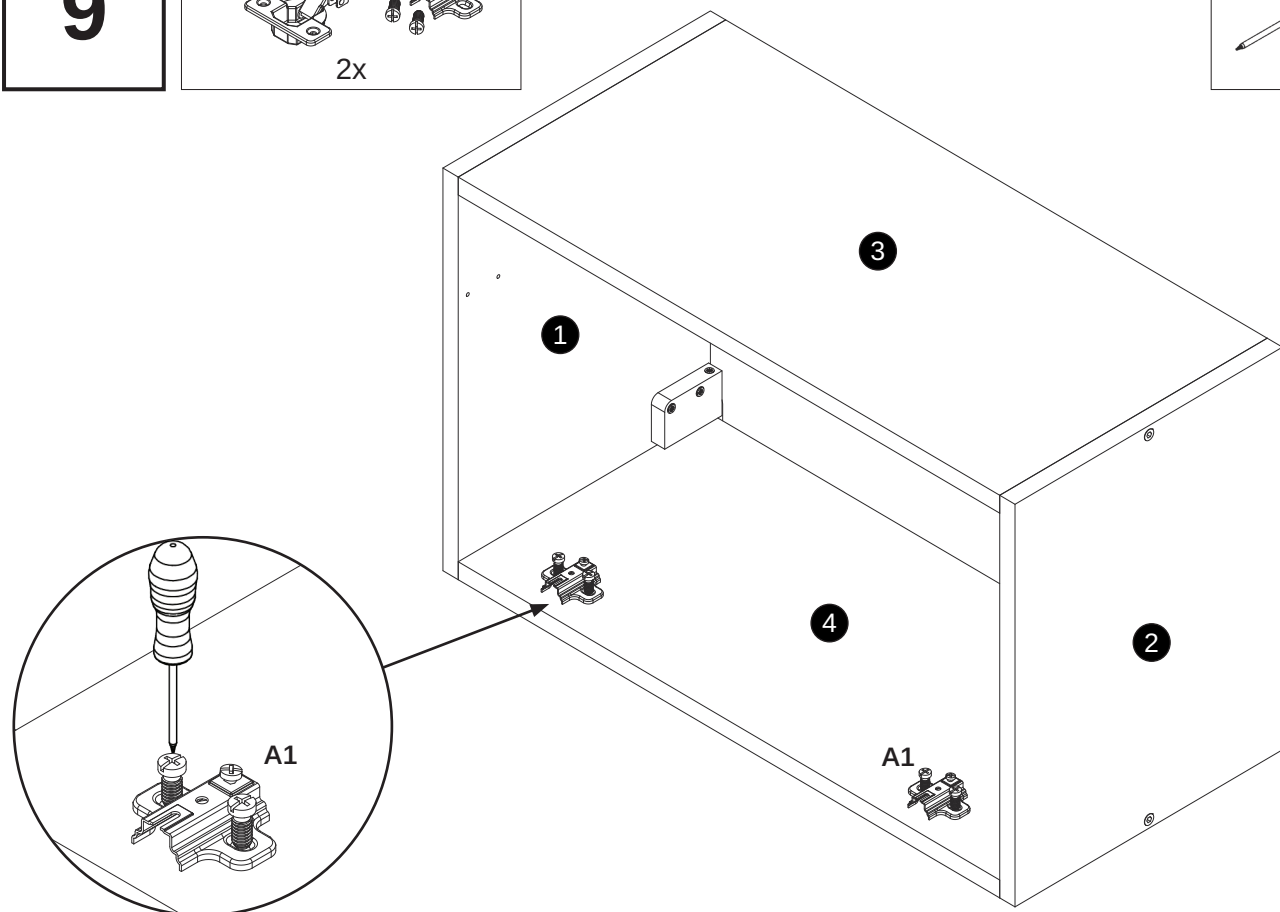

10

! X=Y

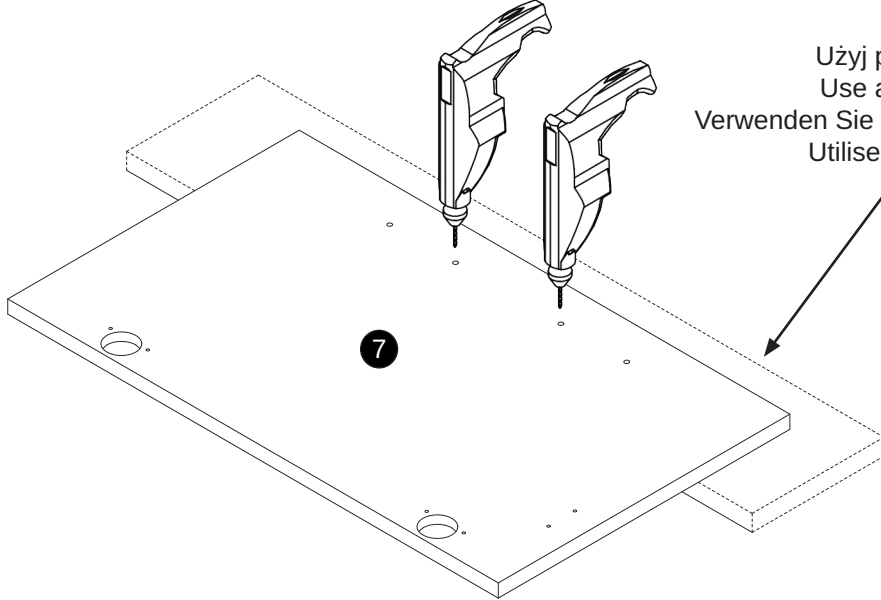
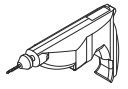
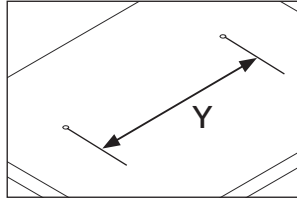
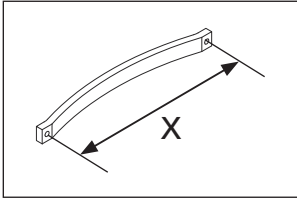

11

U1



1x

P9



2x

A1

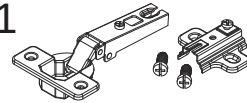

2x

+

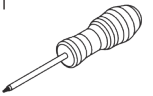

S1c



4x

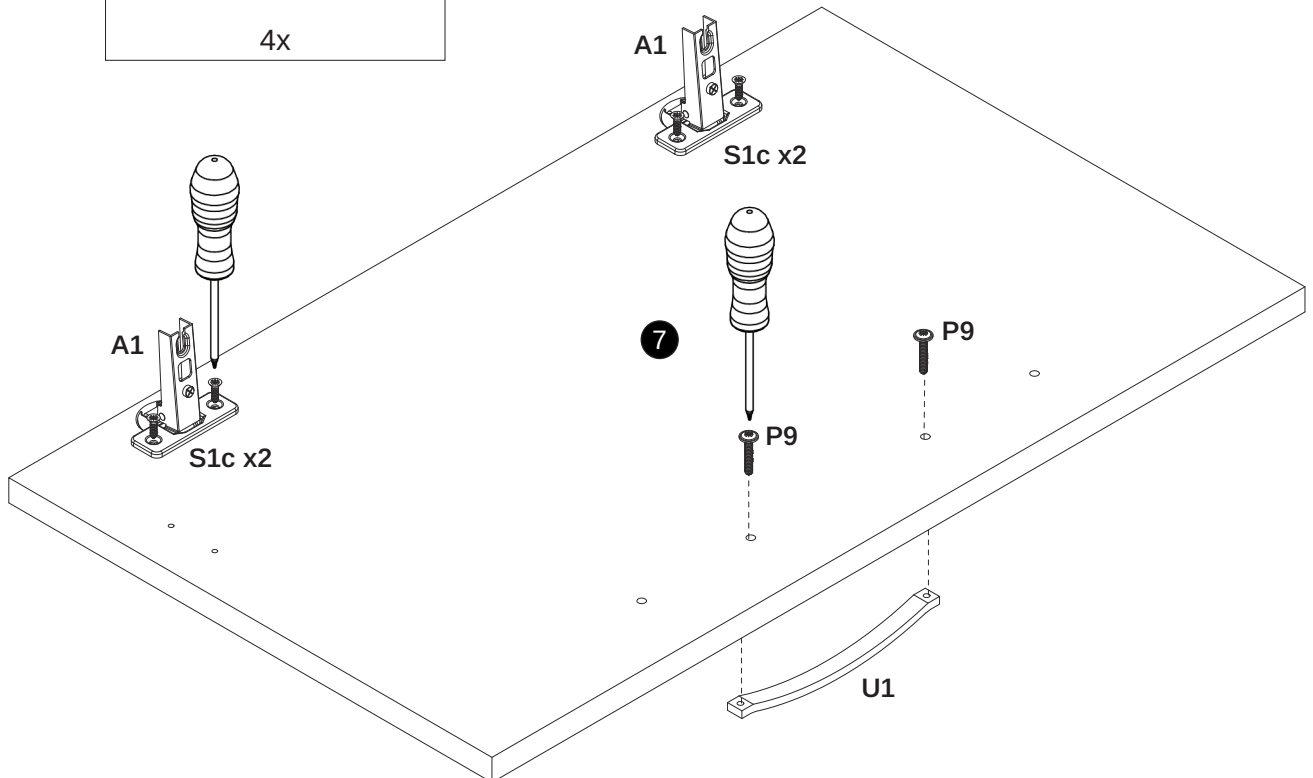

12

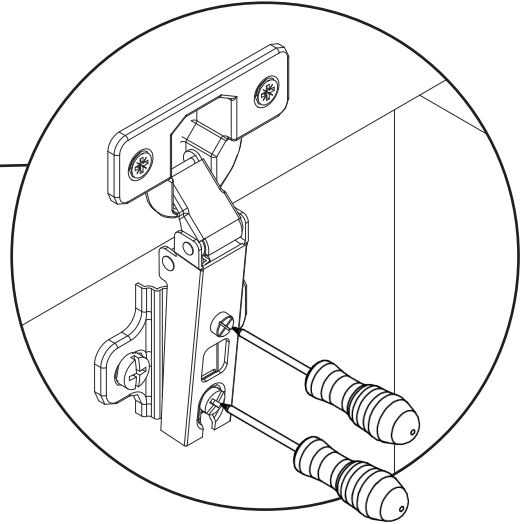
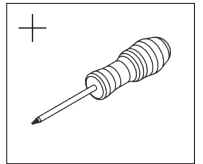
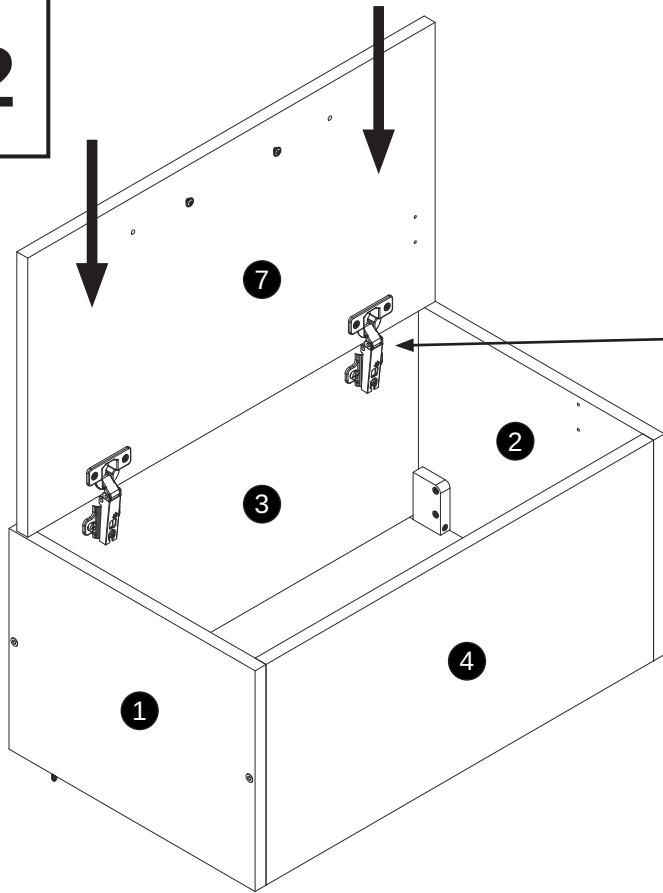

13

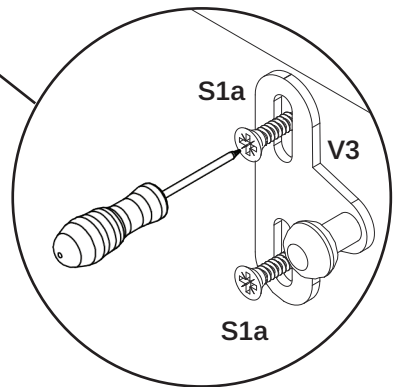
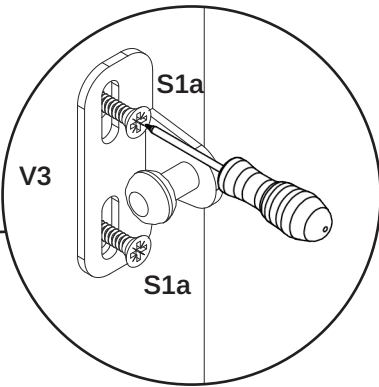
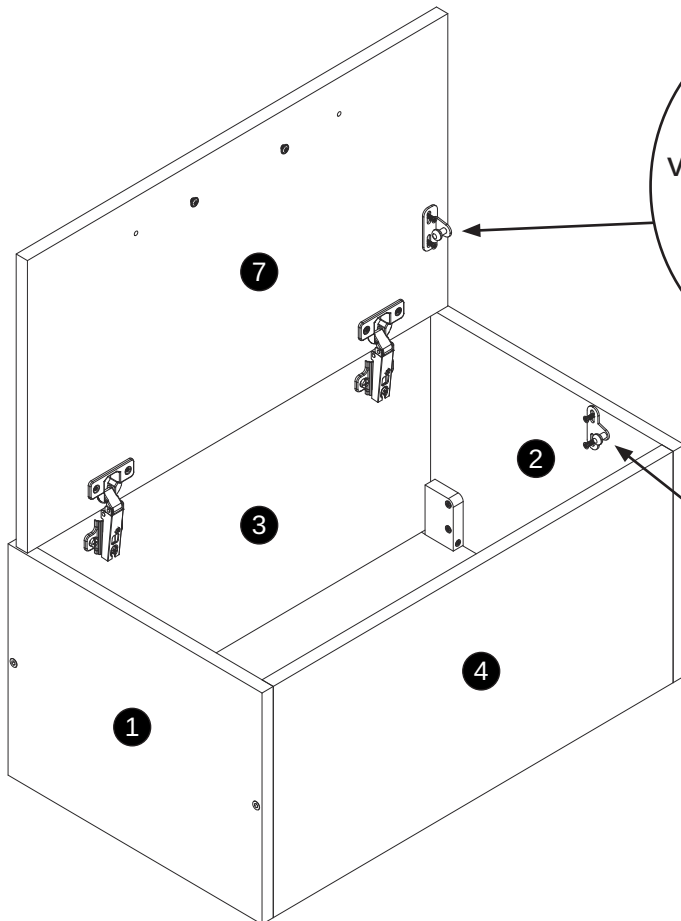
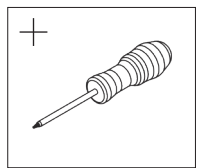
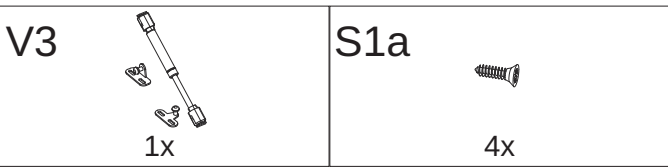

14

V3
1x





D11
x2



F10
x4

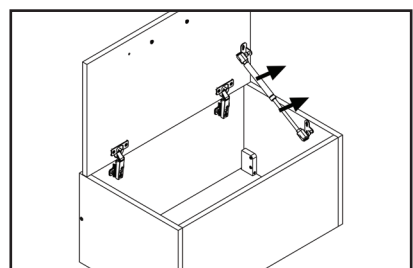
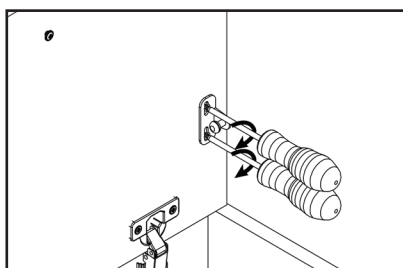
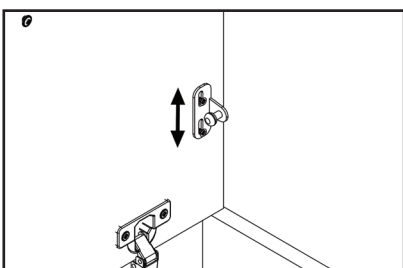
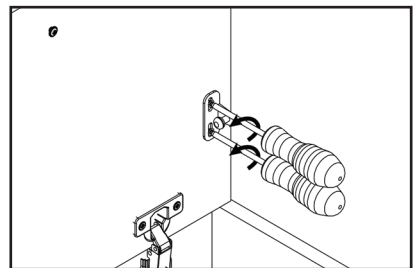
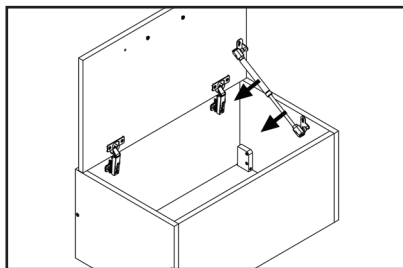
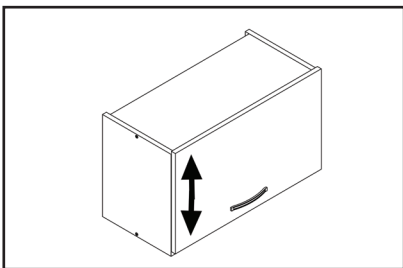
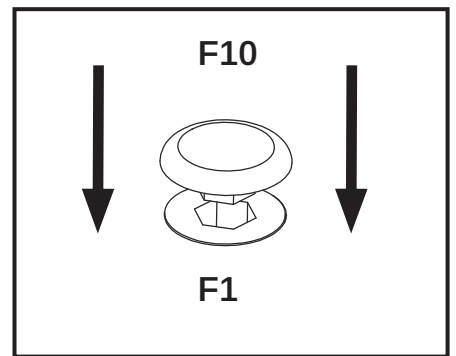
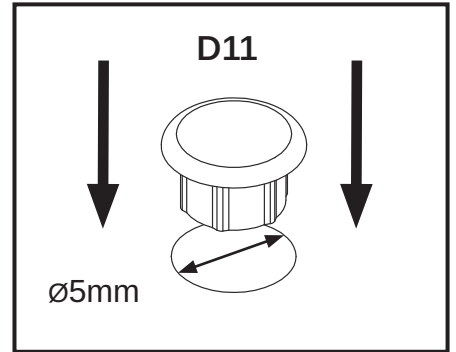
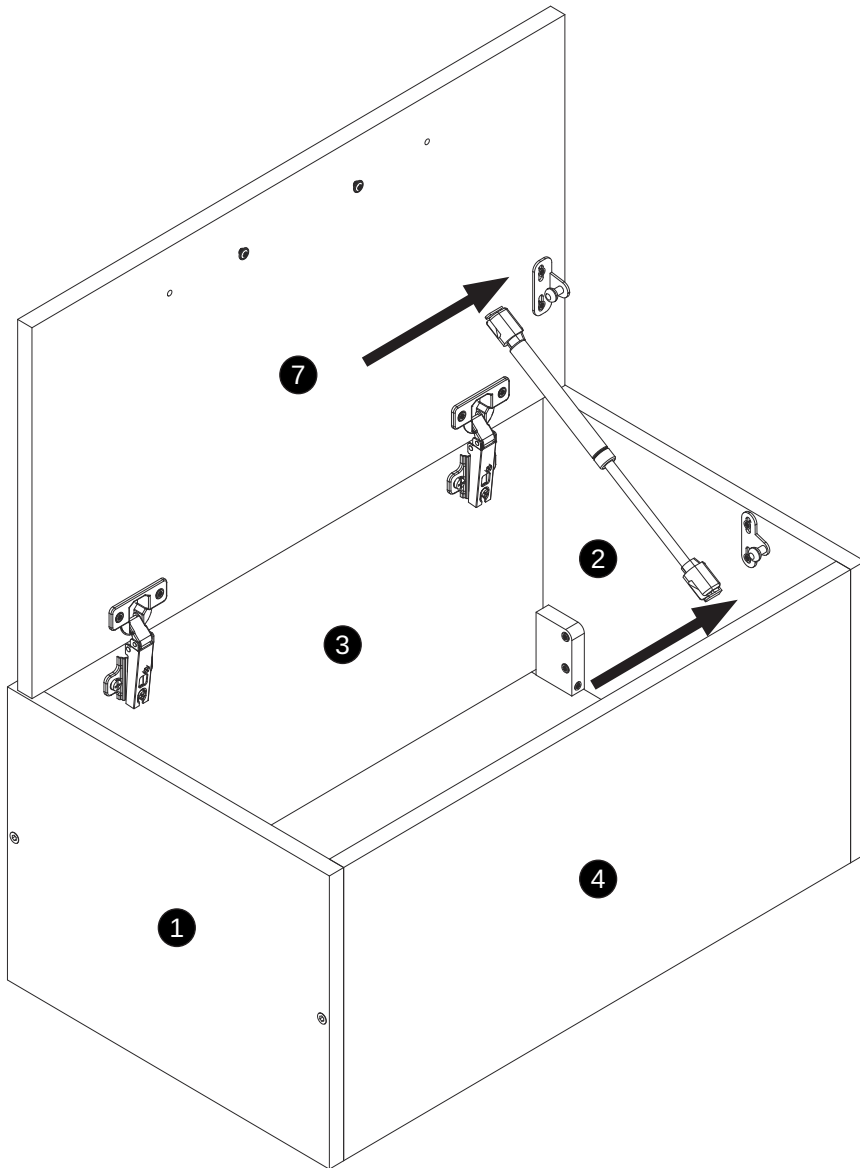

+



15

D2
2x

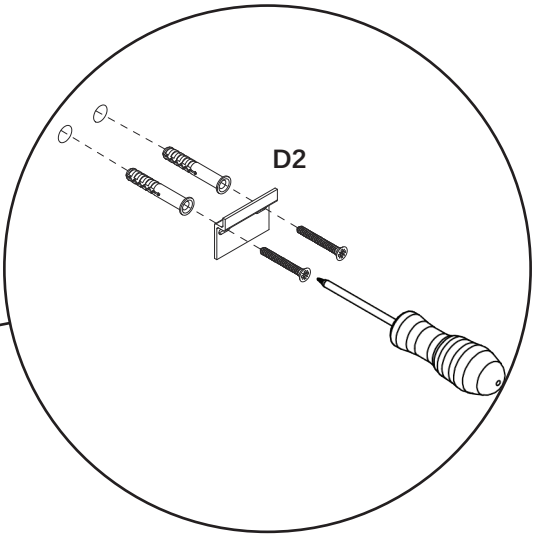
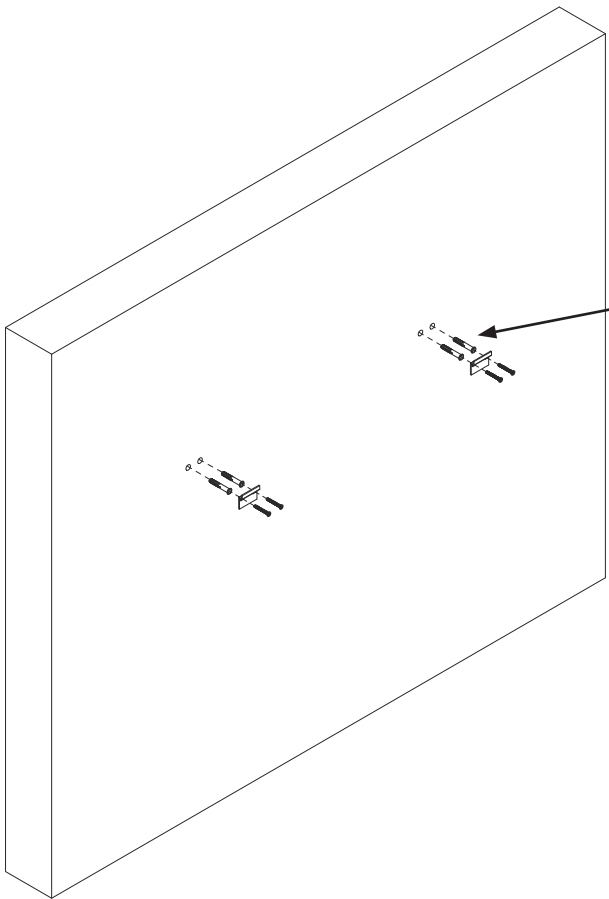
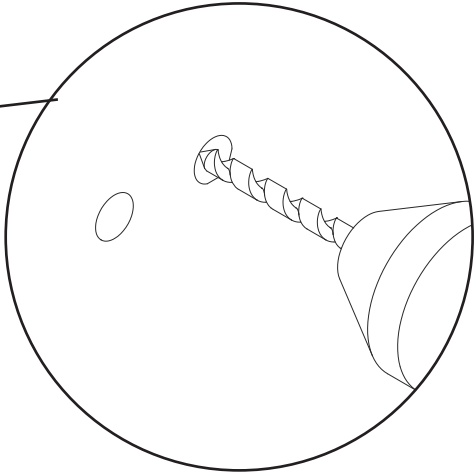
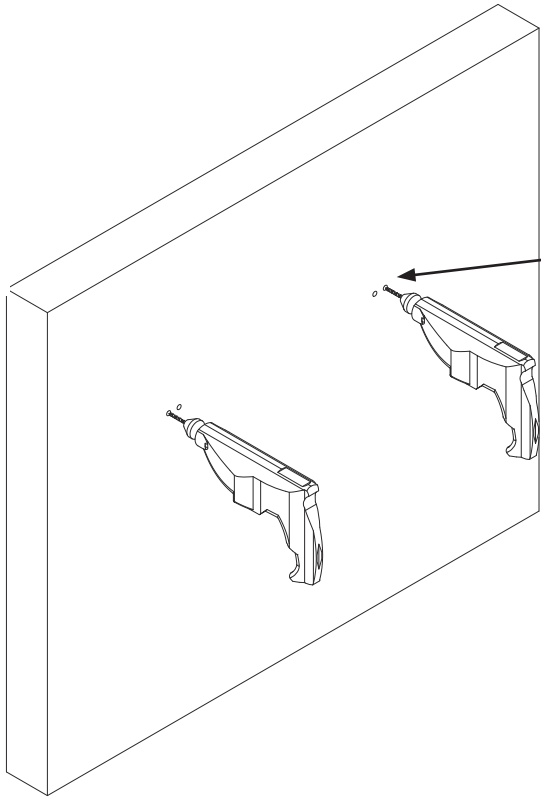
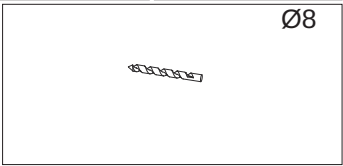
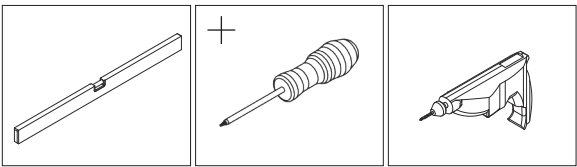

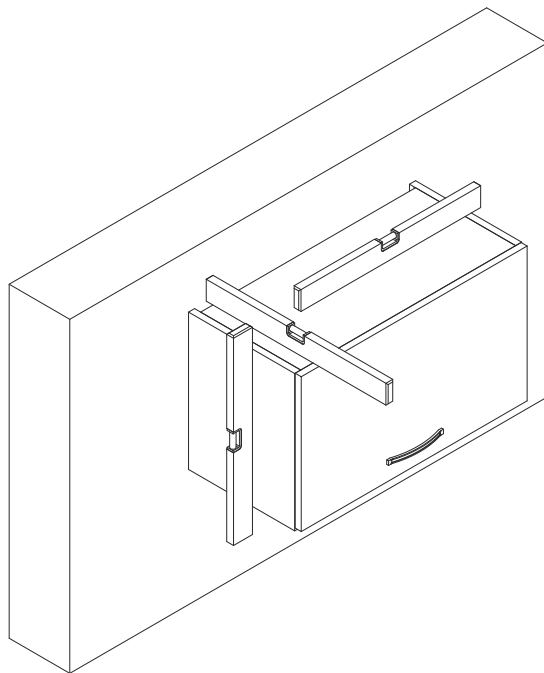
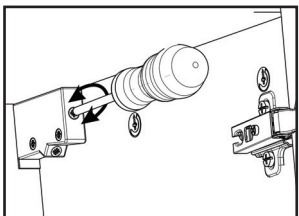
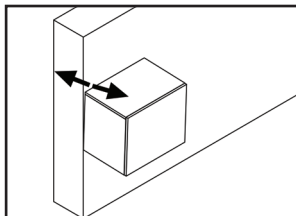
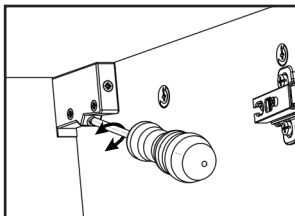
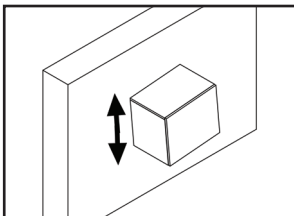
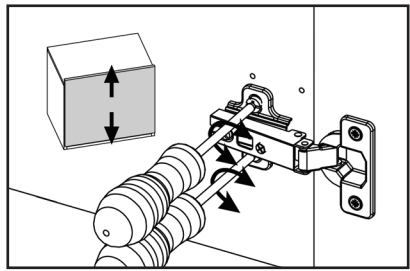
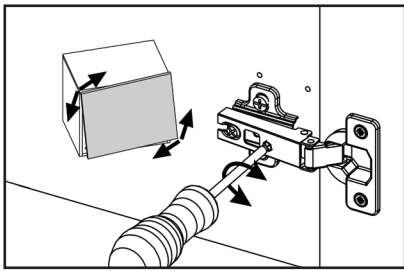
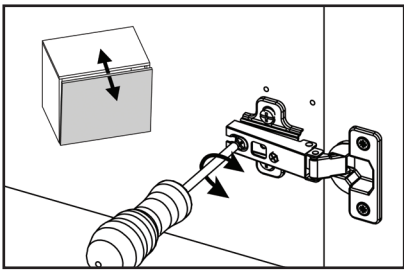
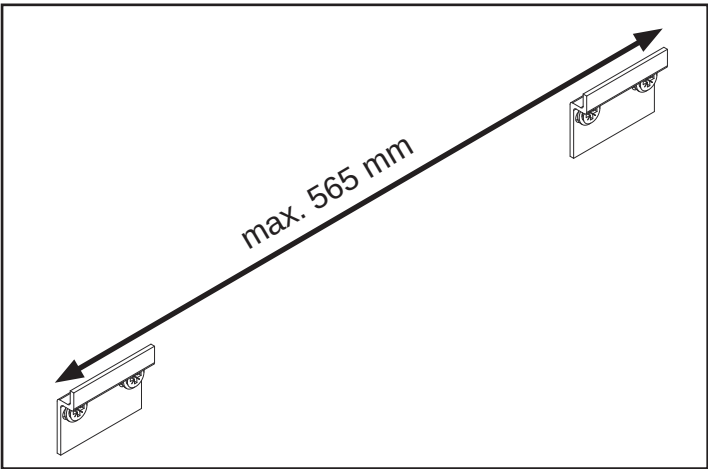
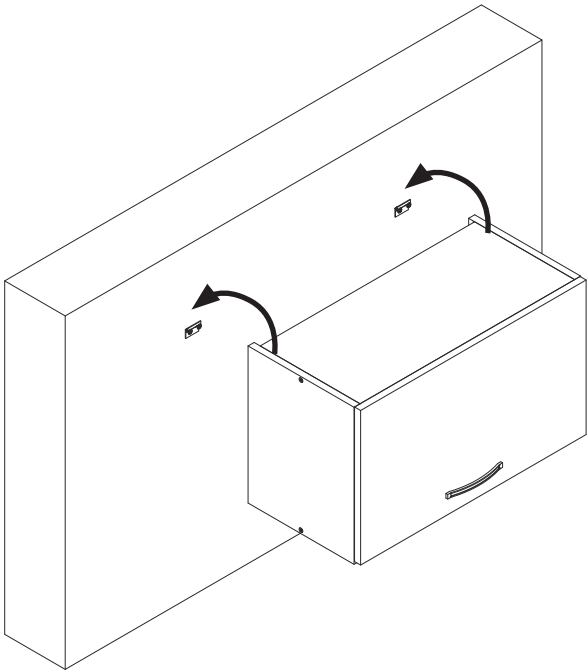

Zasady użytkowania i konserwacji mebli

PL

- Meble należy użytkować w pomieszczeniach suchych, ogrzewanych zabezpieczonych przed szkodliwymi wpływami atmosferycznymi.
- W trakcie użytkowania mebli należy okresowo sprawdzać stan połączeń technicznych takich jak: mimośrodowy, zawiasy, prowadniki.
- Podczas przenoszenia mebli należy chwycić wyłącznie za pionowe elementy konstrukcyjne takie jak boki, nogi. Bezwzględnie nie można chwycić za elementy poziome, takie jak blaty, półki, szuflady, gdyż grozi to poważnymi uszkodzeniami mebli.
- Powierzchnię mebli należy czyścić wyłącznie środkami przeznaczonymi do pielęgnacji mebli.

EN

- Furniture should be kept in dry places which are heated and protected by harmful influence of atmospheric conditions.
- While the furniture is in use there is a necessity to periodically check the state of the technical connections such as: eccentric rods, hinges, guides.
- While furniture is carried it is necessary to keep only the vertical components, such as sides and legs of the furniture.
- The surface of the furniture should be cleaned only with detergents for furniture care.

DE

- Die Möbel soll man in den trockenen, beheizten und vor den schädlichen Witterungseinflüssen gesicherten Räumen benutzen.
- Im Laufe der Benutzung der Möbel soll man zeitlich den Zustand der technischen Verbindungen wie: Exzenter, Türbänder und Leitstücke prüfen.
- Während des Möbeltransports muss man ausschließlich nach vertikalen Konstruktionselementen wie: Ecken und Beine greifen. Auf keinen Fall darf man nach horizontalen Elementen, wie Blätter, Bretter und Schubladen greifen, was zur ernsthaften Möbelbeschädigung bringen kann.
- Die Fläche der Möbel soll man nur mit dazu geeigneten Pflegemöbelmitteln putzen.

FR

- Les meubles doivent être utilisés dans des pièces sèches, chauffées et protégées contre les effets nocifs de la pollution. Les meubles doivent être utilisés dans des locaux secs, chauffés et protégés des influences atmosphériques nocives.
- Lors de l'utilisation du mobilier, l'état des connexions techniques telles que: excentriques, charnières, guides.
- Lorsque vous déplacez le meuble, ne manipulez que les éléments structurels verticaux, tels que les côtés, jambes. Vous ne devez absolument pas saisir les éléments horizontaux tels que les plateaux, les étagères, les tiroirs, car cela peut provoquer des dommages importants au mobilier.
- La surface du meuble doit être nettoyée uniquement avec des produits destinés à l'entretien des meubles.