

# **Moveable Welding Table USER MANUAL**

# Moveable Welding Table

## INSTALLATION INSTRUCTION

Model: WT1200

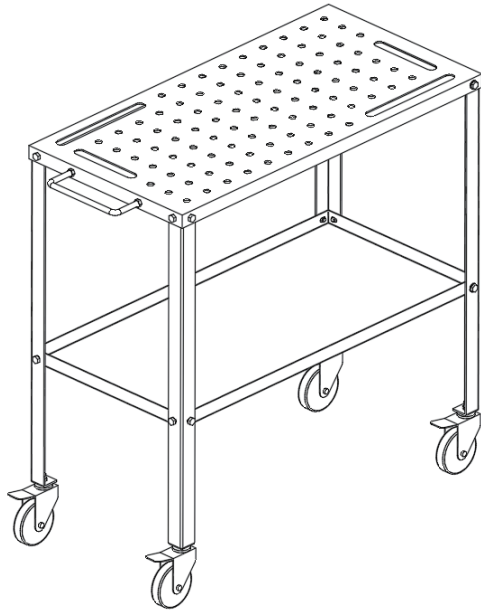

Note: the quantity of parts shown in the manual is the actual usage and the unused parts are spare parts.

## ASSEMBLY PRECAUTIONS

1. Assemble only according to these instructions. Incorrect assembly can be a hazard.
2. Wear safety goggles and heavy-duty work gloves during assembly.
3. Do not assemble when tired or when under the influence of alcohol, drugs or medication.
4. Weight capacity and other product capabilities apply to properly and completely assembled product only.

## USE PRECAUTIONS

1. This product is not a toy. Do not allow children to play with or approach this item.
2. Use as intended only. Do not sit or stand on table.
3. Inspect before every use. Do not use if parts are loose or damaged.
4. Use only on flat, level, hard surface.
5. Do not exceed listed weight capacity. Tighten all knobs securely before applying load.  
Be aware of dynamic loading! Sudden load movement may briefly create excess load causing product failure.
6. **The maximum load of the product is 1200 lb (544 Kg).**

## ASSEMBLY INSTRUCTIONS

For additional information regarding the parts listed in the following pages, refer to the Assembly Diagram of this manual. Unwrap and separate all parts on a clear work area.

## PACKAGE CONTENTS

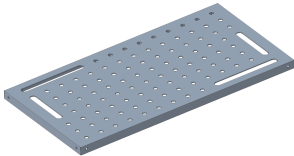

1. Table Top × 1



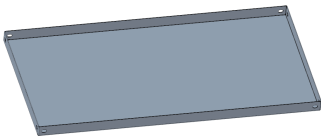

2. Handle × 1

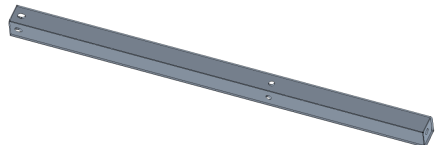

3. Tool palette × 1

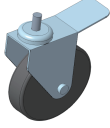

4. Table leg × 4

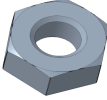
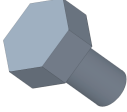
 <p>5. Casters Wheel × 4</p>	 <p>6. M8 Nut × 16</p>
 <p>7. M12 Nut × 4</p>	 <p>8. M10 Nut × 4</p>
 <p>9. M8 Screw × 16</p>	

**ASSEMBLY STEPS**

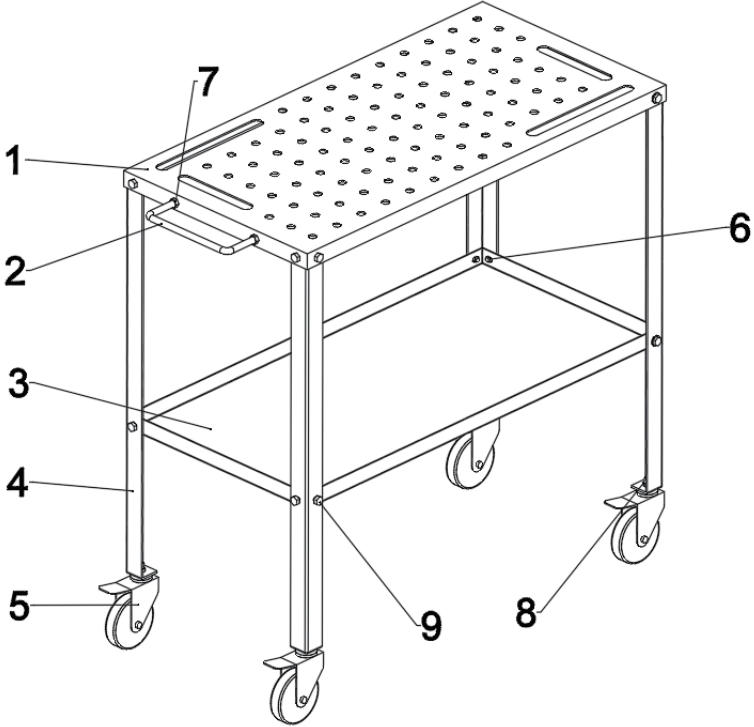

# STEP 1

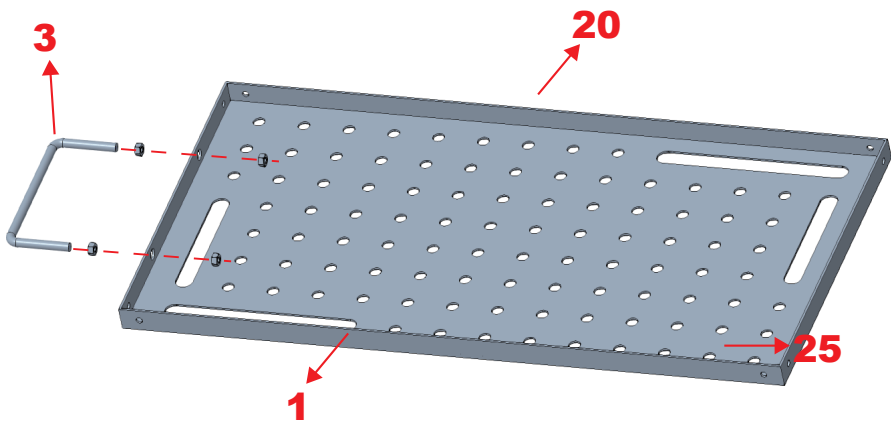

Component 1

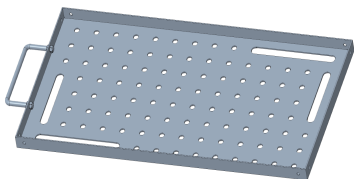

7  × 4

# STEP 2

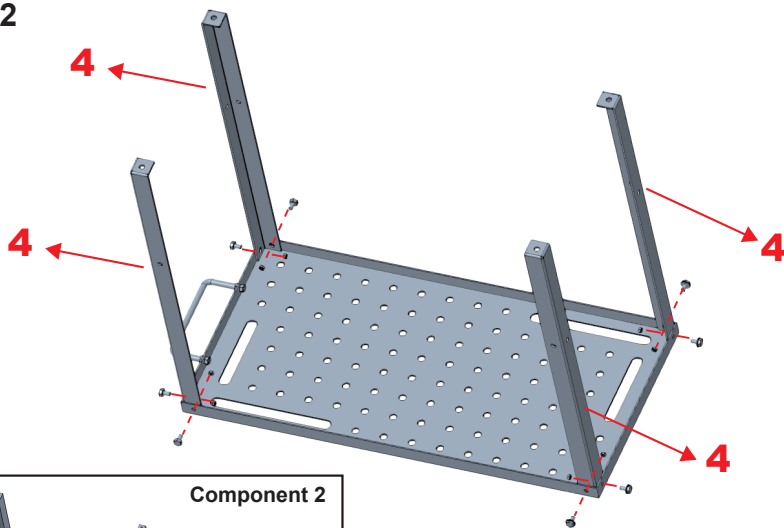

Component 2

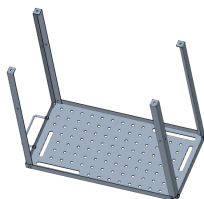



9  × 8

6  × 8

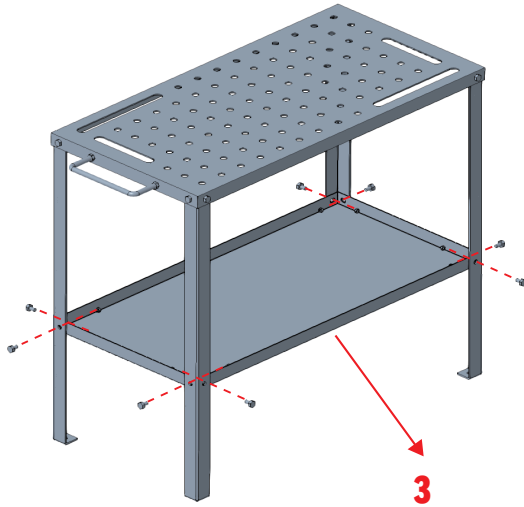
### STEP 3



Component 3

- |   |   |
|---|---|
| 9 |  × 8 |
| 6 |  × 8 |

### STEP 4

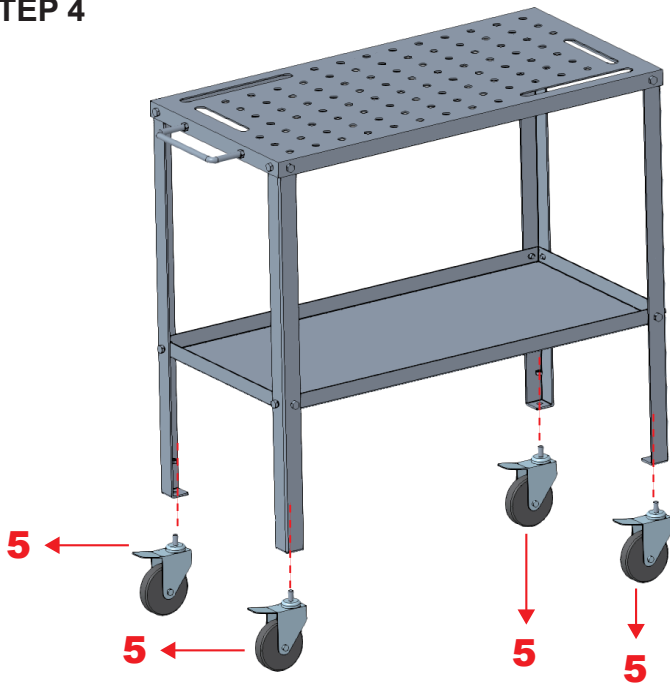

- |   |   |
|---|---|
| 8 |  × 4 |
|---|---|

**Complete your product.**

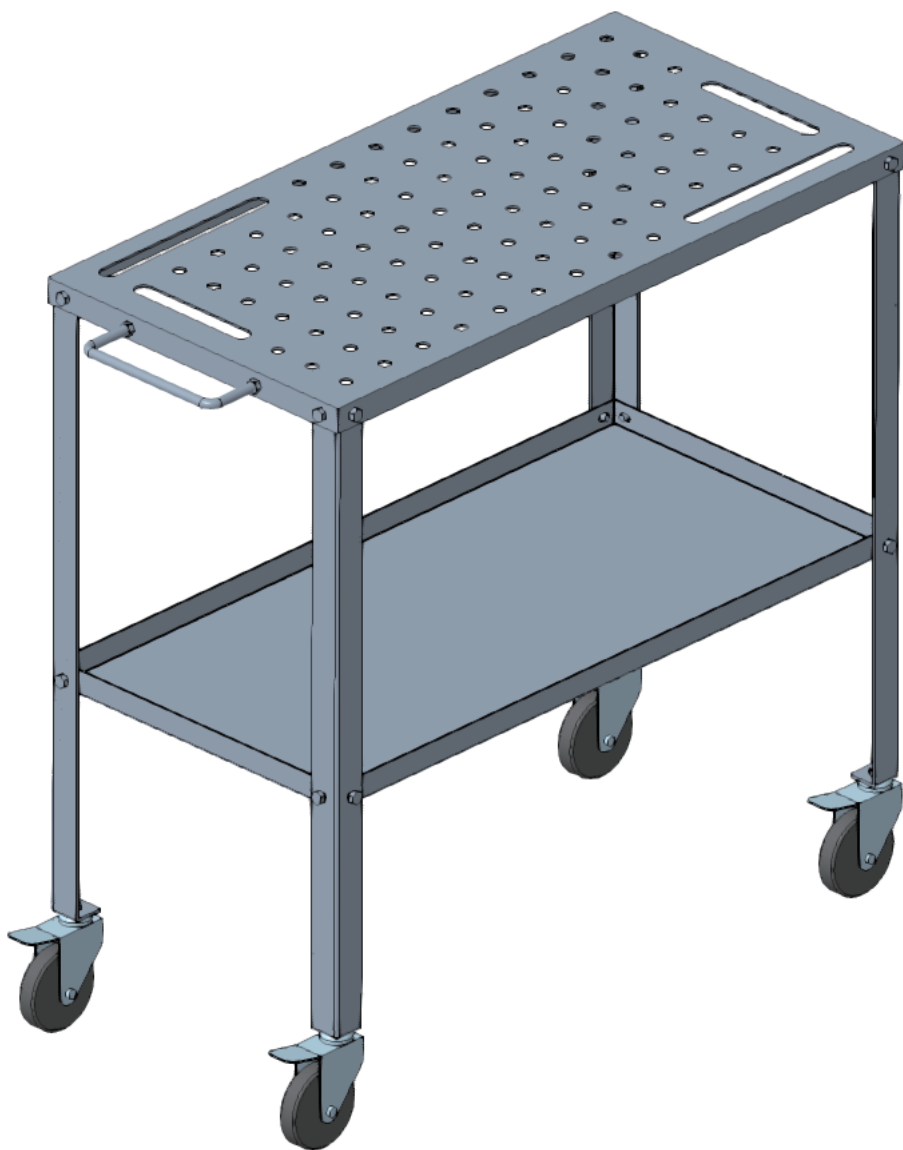

**Address:** Shuangchenglu 803nong11hao1602A-1609shi, baoshanqu, shanghai 200000 CN.

**Imported to AUS:** SIHAO PTY LTD, 1 ROKEVA STREETEASTWOOD NSW 2122 Australia

**Imported to USA:** Sanven Technology Ltd., Suite 250, 9166 Anaheim Place, Rancho Cucamonga, CA 91730

<b>EC</b>	<b>REP</b>
-----------	------------

E-CrossStu GmbH  
Mainzer Landstr.69, 60329 Frankfurt am Main.

<b>UK</b>	<b>REP</b>
-----------	------------

YH CONSULTING LIMITED.  
C/O YH Consulting Limited Office 147, Centurion House,  
London Road, Staines-upon-Thames, Surrey, TW18 4AX

# Table de soudage mobile

## MANUEL D'UTILISATION

# Table de soudage mobile

## INSTRUCTIONS D'INSTALLATION

Modèle : WT1200



Remarque : la quantité de pièces indiquée dans le manuel correspond à l'utilisation réelle et les pièces non utilisées sont des pièces de rechange.

## PRÉCAUTIONS D'ASSEMBLAGE

1. Assemblez uniquement en suivant ces instructions. Un assemblage incorrect peut être dangereux.
2. Portez des lunettes de sécurité et des gants de travail résistants pendant l'assemblage.
3. Ne montez pas lorsque vous êtes fatigué ou sous l'influence de l'alcool, de drogues ou de médicaments.
4. La capacité de poids et les autres capacités du produit s'appliquent aux produits correctement et complètement assemblés, produit uniquement.

## PRÉCAUTIONS D'EMPLOI

1. Ce produit n'est pas un jouet. Ne laissez pas les enfants jouer avec ou s'en approcher.
2. Utiliser uniquement comme prévu. Ne pas s'asseoir ou se tenir debout sur la table.
3. Inspectez l'appareil avant chaque utilisation. N'utilisez pas l'appareil si certaines pièces sont desserrées ou endommagées.
4. Utiliser uniquement sur une surface plane, horizontale et dure.
5. Ne pas dépasser la capacité de poids indiquée. Bien serrer tous les boutons avant d'appliquer la charge.  
Soyez attentif aux charges dynamiques ! Un mouvement de charge soudain peut brièvement créer une charge excessive entraînant une défaillance du produit.
6. La charge maximale du produit est de 1 200 lb (544 kg).

## INSTRUCTIONS DE MONTAGE

Pour plus d'informations sur les pièces répertoriées dans les pages suivantes, reportez-vous au schéma d'assemblage de ce manuel. Déballez et séparez toutes les pièces sur une zone de travail dégagée.

## CONTENU DU COLIS



1. Plateau de table × 1







2. Poignée × 1



3. Palette d'outils × 1



4. Pied de table × 4

 <p>5. Roulettes × 4</p>	 <p>6. Écrou M8 × 16</p>
 <p>7. Écrou M12 × 4</p>	 <p>8. Écrou M10 × 4</p>
 <p>9. Vis M8 × 16</p>	

## ÉTAPES D'ASSEMBLAGE

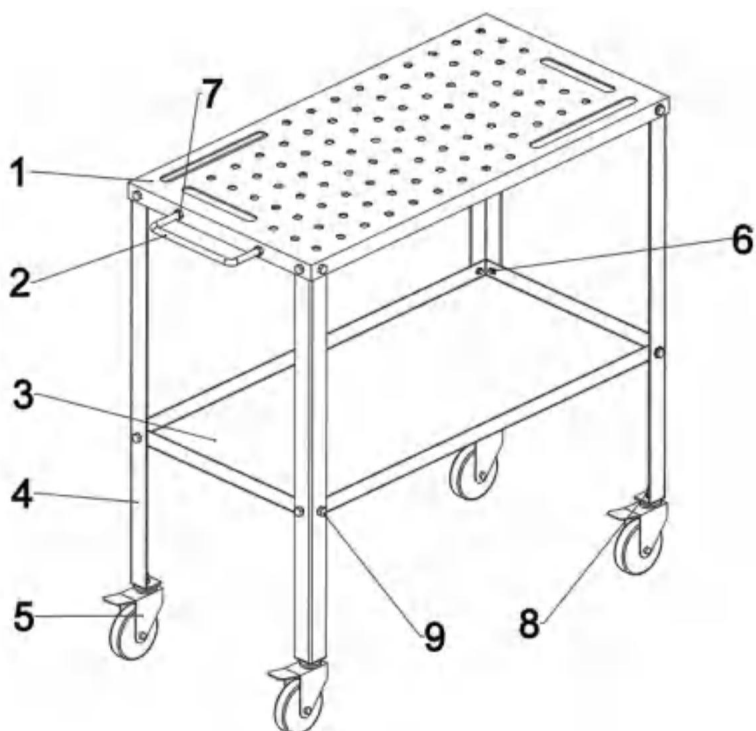

### ÉTAPE 1

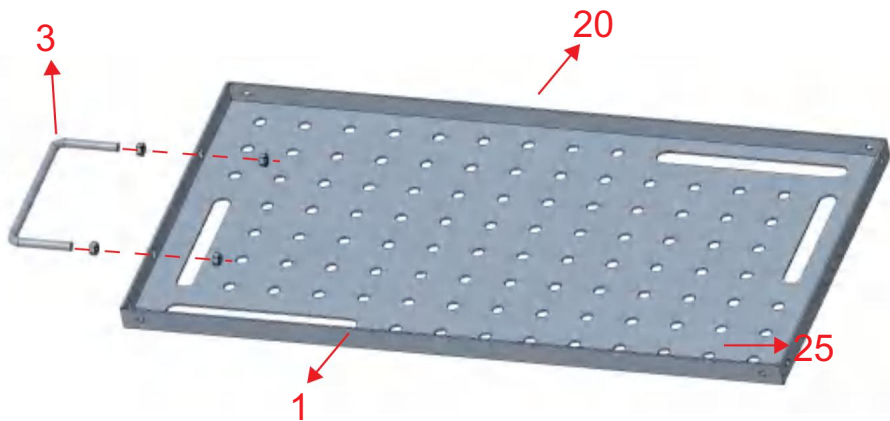

Composante 1



7  x 4

### ÉTAPE 2

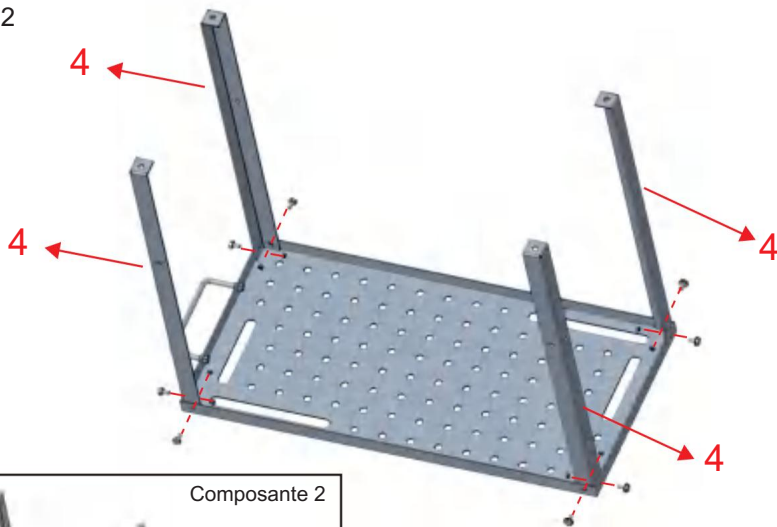

Composante 2



9  x 8

6  x 8

### ÉTAPE 3

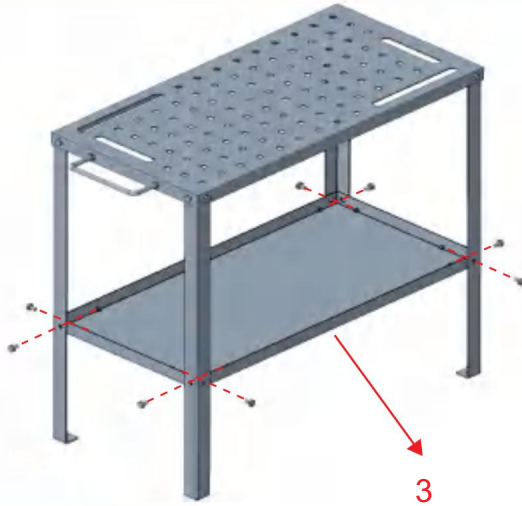

Composante 3



9  × 8

6  × 8

### ÉTAPE 4



8  × 4

Complétez votre produit.





# **Beweglicher Schweißisch**

## **BENUTZERHANDBUCH**

# Beweglicher Schweißstisch

## INSTALLATIONSANLEITUNG

Modell: WT1200



Hinweis: Die in der Anleitung angegebene Teilmenge entspricht der tatsächlichen Nutzung und die nicht verwendeten Teile sind Ersatzteile.

## VORSICHTSMASSNAHMEN BEI DER MONTAGE

1. Bauen Sie das Gerät nur gemäß dieser Anleitung zusammen. Eine falsche Montage kann gefährlich sein.
2. Tragen Sie während der Montage eine Schutzbrille und strapazierfähige Arbeitshandschuhe.
3. Nicht montieren, wenn Sie müde sind oder unter dem Einfluss von Alkohol, Drogen oder Medikamenten stehen.
4. Die Gewichtskapazität und andere Produkteigenschaften gelten für ordnungsgemäß und vollständig montierte nur Produkt.

## VORSICHTSMASSNAHMEN BEIM GEBRAUCH

1. Dieses Produkt ist kein Spielzeug. Erlauben Sie Kindern nicht, mit diesem Produkt zu spielen oder sich ihm zu nähern.
2. Nur bestimmungsgemäß verwenden. Nicht auf dem Tisch sitzen oder stehen.
3. Vor jedem Gebrauch überprüfen. Nicht verwenden, wenn Teile lose oder beschädigt sind.
4. Nur auf flachen, ebenen und harten Oberflächen verwenden.
5. Die angegebene Gewichtskapazität darf nicht überschritten werden. Ziehen Sie alle Knöpfe fest an, bevor Sie eine Last aufbringen.  
Achten Sie auf dynamische Belastungen! Plötzliche Lastbewegungen können kurzzeitig zu einer Überlastung und damit zu Produktversagen führen.
6. Die maximale Belastung des Produkts beträgt 1200 lb (544 kg).

## MONTAGEANLEITUNG

Weitere Informationen zu den auf den folgenden Seiten aufgeführten Teilen finden Sie im Montagediagramm dieses Handbuchs. Packen Sie alle Teile auf einem freien Arbeitsbereich aus und trennen Sie sie voneinander.

## PACKUNGSGEHALT



1. Tischplatte x 1







2. Griff x 1



3. Werkzeugpalette x 1



4. Tischbein x 4

 <p>5. Lenkrollen x 4</p>	 <p>6. M8 Mutter x 16</p>
 <p>7. M12 Mutter x 4</p>	 <p>8. M10 Mutter x 4</p>
 <p>9. M8 Schraube x 16</p>	

## MONTAGEANLEITUNG

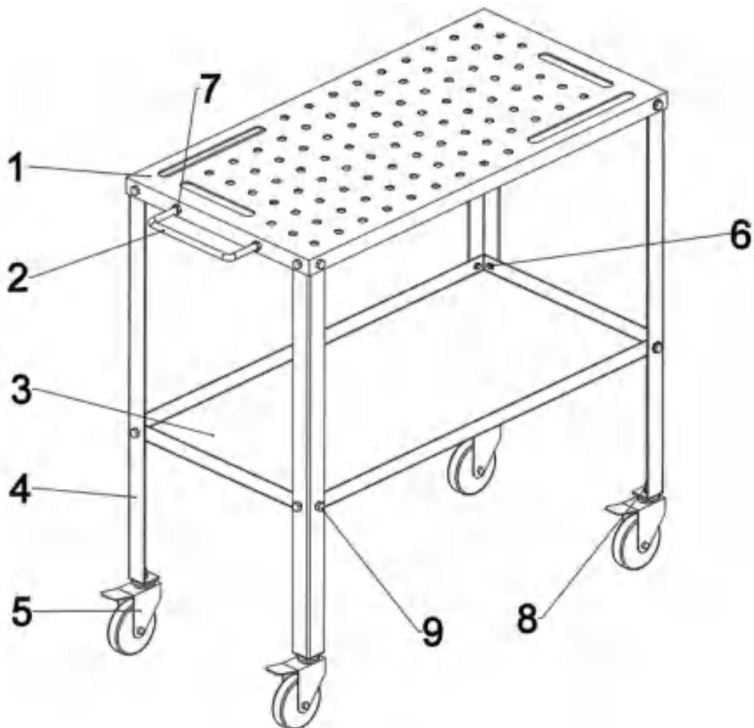

### SCHRITT 1

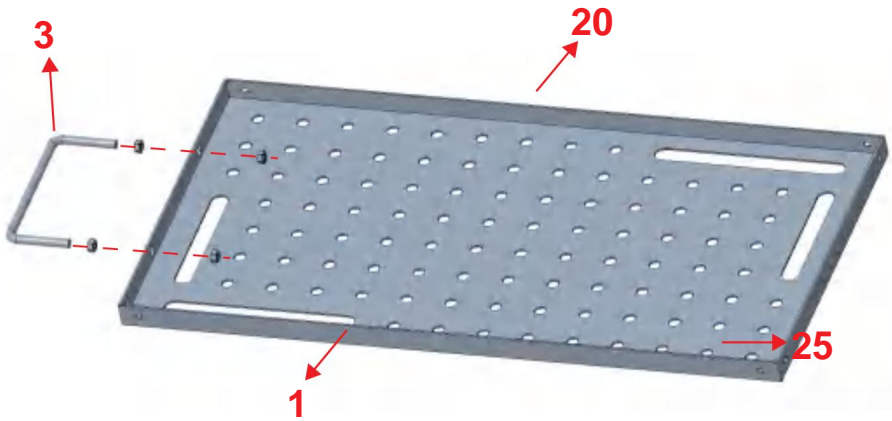

Komponente 1



7  x 4

### SCHRITT 2

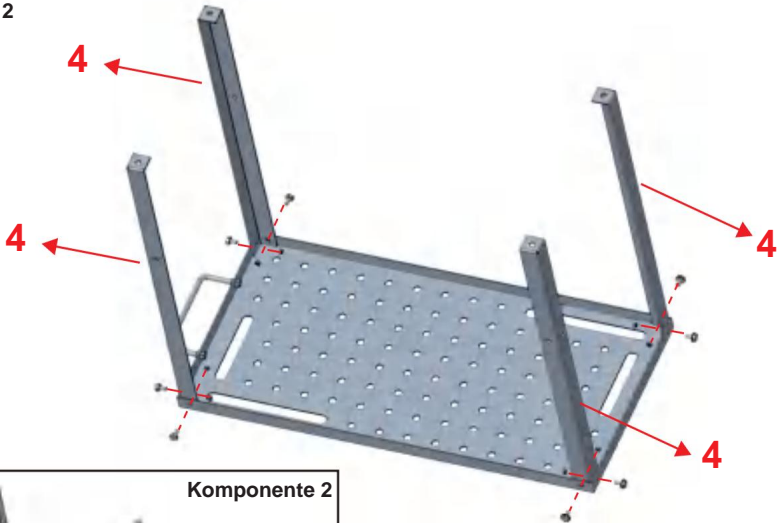

Komponente 2



9  x 8

6  x 8

### SCHRITT 3

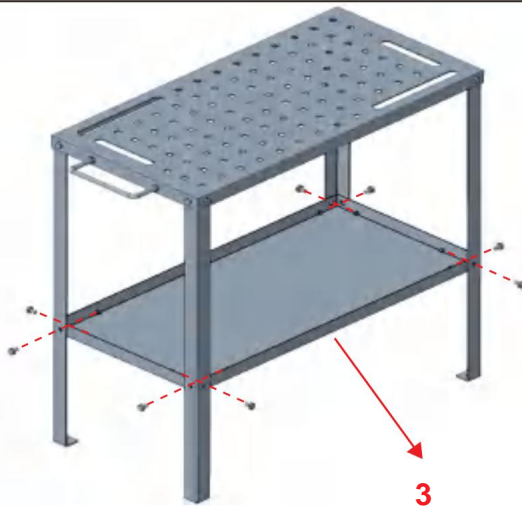

Komponente 3



9  x 8

6  x 8

### SCHRITT 4



8  x 4

**Vervollständigen Sie Ihr Produkt.**





# **Tavolo di saldatura mobile**

## **MANUALE D'USO**

# Tavolo di saldatura mobile

## ISTRUZIONI PER L'INSTALLAZIONE

Modello: WT1200



Nota: la quantità di parti indicata nel manuale corrisponde all'uso effettivo e le parti non utilizzate sono pezzi di ricambio.

## PRECAUZIONI DI MONTAGGIO

1. Montare solo secondo queste istruzioni. Un montaggio non corretto può essere pericoloso.
2. Durante il montaggio, indossare occhiali protettivi e guanti da lavoro resistenti.
3. Non riunirsi quando si è stanchi o sotto l'effetto di alcol, droghe o farmaci.
4. La capacità di peso e le altre capacità del prodotto si applicano a prodotti correttamente e completamente assemblati solo prodotto.

## PRECAUZIONI D'USO

1. Questo prodotto non è un giocattolo. Non permettere ai bambini di giocare con questo articolo o di avvicinarsi ad esso.
2. Utilizzare solo come previsto. Non sedersi o stare in piedi sul tavolo.
3. Ispezionare prima di ogni utilizzo. Non utilizzare se le parti sono allentate o danneggiate.
4. Utilizzare solo su superfici piane, livellate e dure.
5. Non superare la capacità di peso indicata. Serrare saldamente tutte le manopole prima di applicare il carico.  
Siate consapevoli del carico dinamico! Un movimento improvviso del carico può creare brevemente un carico eccessivo, causando il guasto del prodotto.
6. Il carico massimo del prodotto è di 1200 libbre (544 kg).

## ISTRUZIONI DI MONTAGGIO

Per ulteriori informazioni sulle parti elencate nelle pagine seguenti, fare riferimento allo schema di montaggio di questo manuale. Disimballare e separare tutte le parti su un'area di lavoro libera.

## CONTENUTO DELLA CONFEZIONE



1. Piano del tavolo x 1







2. Maniglia x 1



3. Tavolozza degli strumenti x 1



4. Gamba del tavolo x 4

 <p>5. Ruote girevoli x 4</p>	 <p>6. Dado M8 x 16</p>
 <p>7. Dado M12 x 4</p>	 <p>8. Dado M10 x 4</p>
 <p>9. Vite M8 x 16</p>	

## FASI DI MONTAGGIO

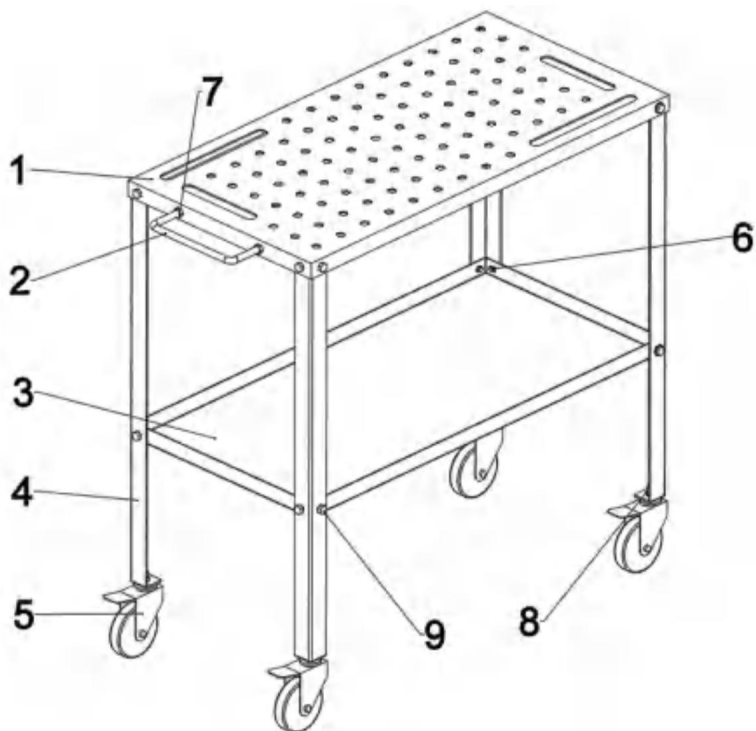

### PASSO 1

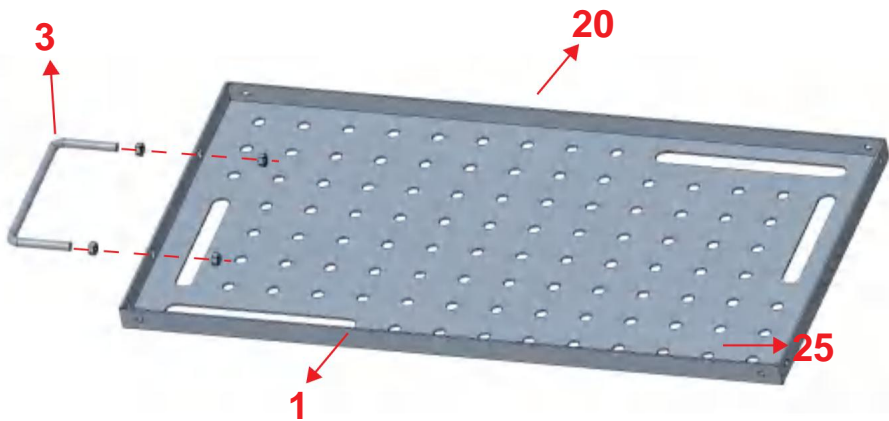

Componente 1



7  x 4

### PASSO 2

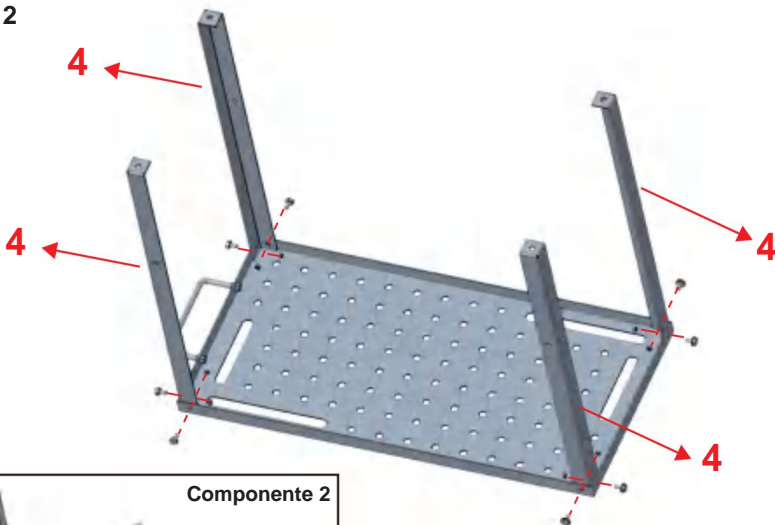

Componente 2



9  x 8

6  x 8

### PASSO 3

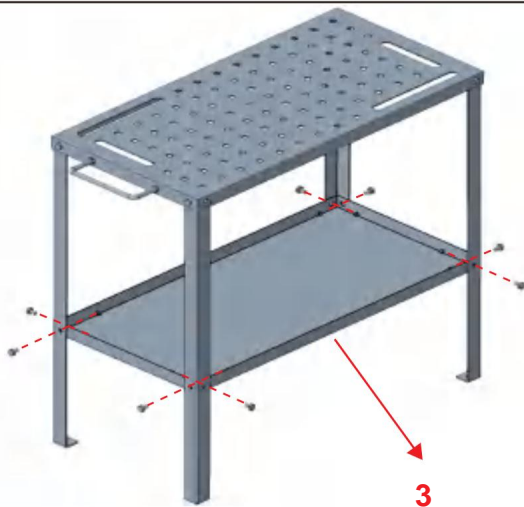

Componente 3



9  x 8

6  x 8

### PASSO 4



8  x 4

**Completa il tuo prodotto.**





# Mesa de soldadura móvil

## MANUAL DEL USUARIO

# Mesa de soldadura móvil

INSTRUCCIONES DE INSTALACIÓN

Modelo: WT1200



Nota: la cantidad de piezas que se muestra en el manual es el uso real y las piezas no utilizadas son piezas de repuesto.

## PRECAUCIONES DE MONTAJE

1. Realice el montaje únicamente de acuerdo con estas instrucciones. Un montaje incorrecto puede suponer un riesgo.
2. Use gafas de seguridad y guantes de trabajo resistentes durante el montaje.
3. No se reúna cuando esté cansado o bajo la influencia del alcohol, drogas o medicamentos.
4. La capacidad de peso y otras capacidades del producto se aplican a productos ensamblados de manera correcta y completa.  
Sólo producto.

## PRECAUCIONES DE USO

1. Este producto no es un juguete. No permita que los niños jueguen con este artículo ni se acerquen a él.
2. Utilícelo únicamente para el fin previsto. No se sienta ni se pare sobre una mesa.
3. Inspeccione el producto antes de cada uso. No lo utilice si hay piezas sueltas o dañadas.
4. Úselo únicamente en superficies planas, niveladas y duras.
5. No exceda la capacidad de peso indicada. Ajuste bien todas las perillas antes de aplicar la carga.  
¡Tenga cuidado con la carga dinámica! El movimiento repentino de la carga puede generar brevemente un exceso de carga que provoque la falla del producto.
6. La carga máxima del producto es de 1200 lb (544 Kg).

## INSTRUCCIONES DE MONTAJE

Para obtener información adicional sobre las piezas que se enumeran en las páginas siguientes, consulte el diagrama de ensamblaje de este manual. Desenvuelva y separe todas las piezas en un área de trabajo despejada.

## CONTENIDO DEL PAQUETE



1. Tablero de mesa × 1







2. Mango × 1



3. Paleta de herramientas × 1



4. Pata de mesa × 4

 <p>5. Ruedas giratorias × 4</p>	 <p>6. Tuerca M8 × 16</p>
 <p>7. Tuerca M12 × 4</p>	 <p>8. Tuerca M10 × 4</p>
 <p>9. Tornillo M8 × 16</p>	

## PASOS DE MONTAJE

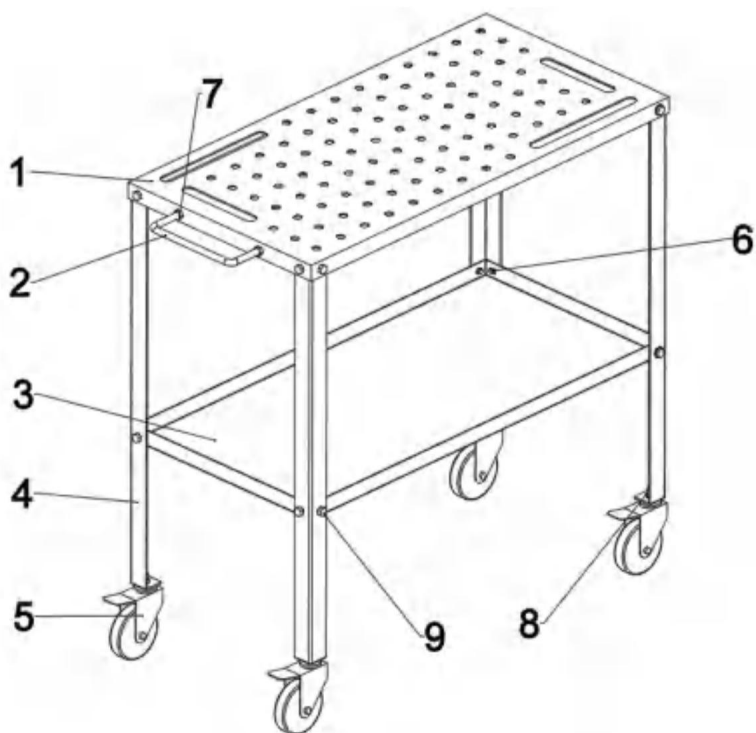

### PASO 1

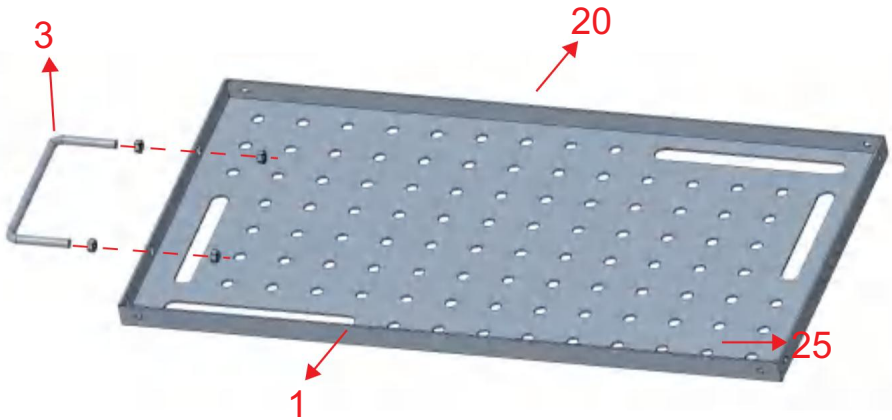

Componente 1



7  × 4

### PASO 2

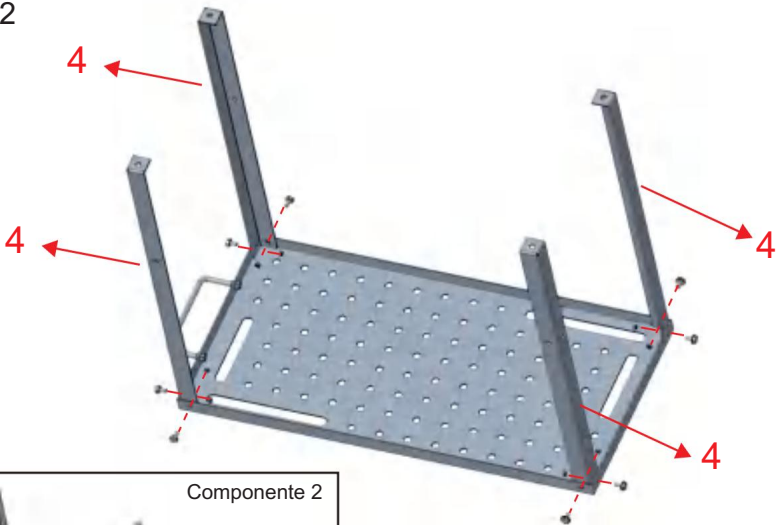

Componente 2



9  × 8

6  × 8

### PASO 3

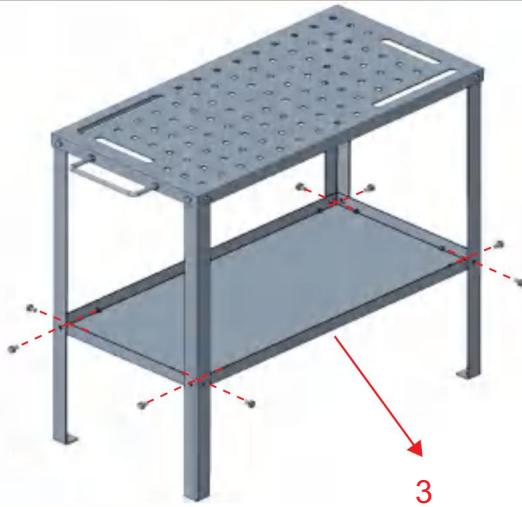

Componente 3



- |   |   |     |
|---|---|-----|
| 9 |  | × 8 |
| 6 |  | × 8 |

### PASO 4



- |   |   |     |
|---|---|-----|
| 8 |  | × 4 |
|---|---|-----|

Completa tu producto.





# Ruchomy stół spawalniczy

## INSTRUKCJA OBSŁUGI

# Ruchomy stół spawalniczy

## INSTRUKCJA INSTALACJI

Model: WT1200



Uwaga: ilość części podana w instrukcji oznacza faktyczne zużycie, części nieużywane są częściami zamiennymi.

## ŚRODKI OSTROŻNOŚCI PODCZAS MONTAŻU

1. Montaż należy wykonywać wyłącznie zgodnie z niniejszą instrukcją. Nieprawidłowy montaż może być niebezpieczny.
2. Podczas montażu należy nosić okulary ochronne i solidne rękawice robocze.
3. Nie przychodź na spotkania, jeśli jesteś zmęczony lub pod wpływem alkoholu, narkotyków lub leków.
4. Nośność i inne parametry produktu dotyczą produktu prawidłowo i całkowicie zmontowanego.  
tylko produkt.

## ŚRODKI OSTROŻNOŚCI

1. Ten produkt nie jest zabawką. Nie pozwalaj dzieciom bawić się tym przedmiotem ani zbliżać się do niego.
2. Używać wyłącznie zgodnie z przeznaczeniem. Nie siadać ani nie stawać na stole.
3. Przed każdym użyciem sprawdź. Nie używaj, jeśli części są luźne lub uszkodzone.
4. Stosować wyłącznie na płaskiej, równej i twardej powierzchni.
5. Nie przekraczaj podanego udźwigu. Przed zastosowaniem obciążenia dokręć mocno wszystkie pokręta.  
Należy pamiętać o dynamicznym obciążeniu! Nagły ruch obciążenia może chwilowo spowodować nadmierne obciążenie powodujące awarię produktu.
6. Maksymalne obciążenie produktu wynosi 1200 funtów (544 kg).

## INSTRUKCJA MONTAŻU

Aby uzyskać dodatkowe informacje dotyczące części wymienionych na kolejnych stronach, zapoznaj się ze schematem montażu w tym podręczniku. Rozpakuj i oddziel wszystkie części na czystym obszarze roboczym.

## ZAWARTOŚĆ OPAKOWANIA



1. Błat stołu × 1





2. Uchwyt × 1



3. Paleta narzędzi × 1



4. Noga stołu × 4

 <p>5. Kółka × 4</p>	 <p>6. Nakrętka M8 × 16</p>
 <p>7. Nakrętka M12 × 4</p>	 <p>8. Nakrętka M10 × 4</p>
 <p>9. Śruba M8 × 16</p>	

## KROKI MONTAŻU

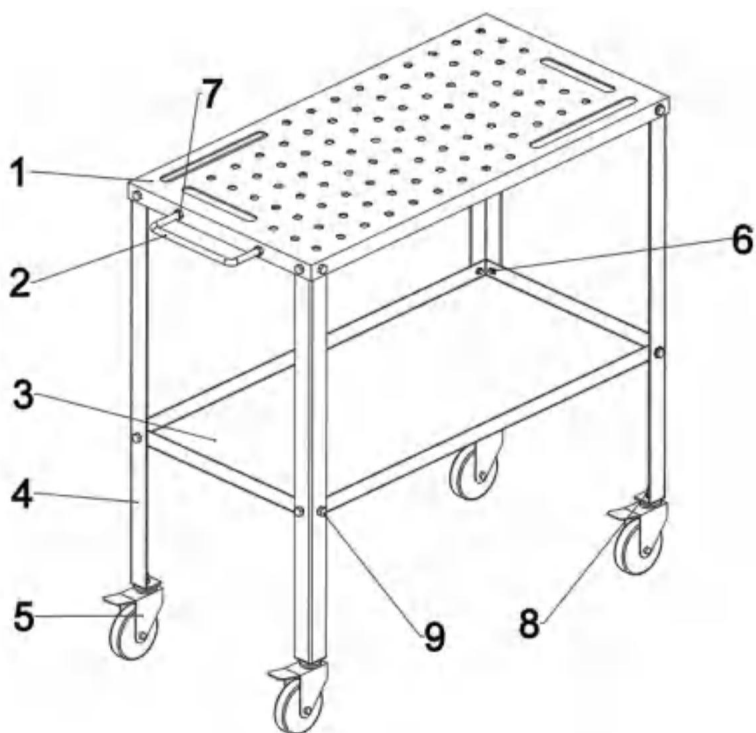

### KROK 1

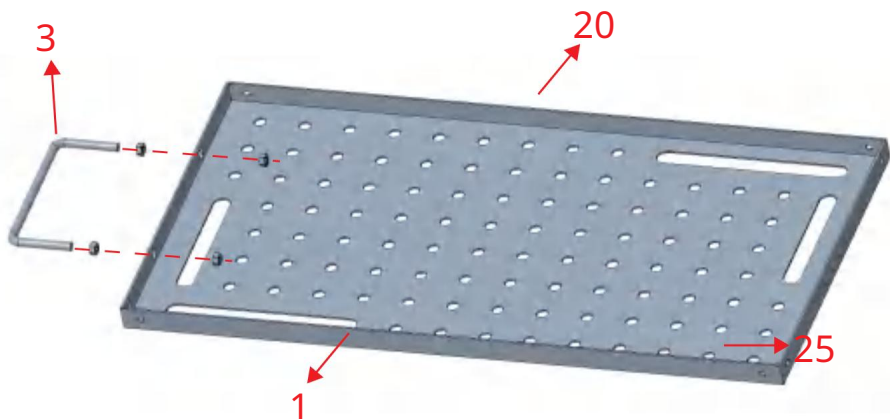

Składnik 1



7  ×4

### KROK 2

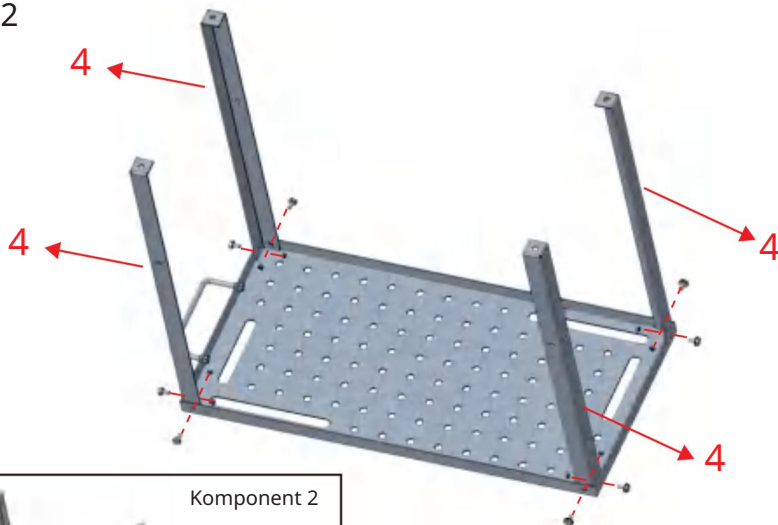

Komponent 2



9  ×8

6  ×8

### KROK 3

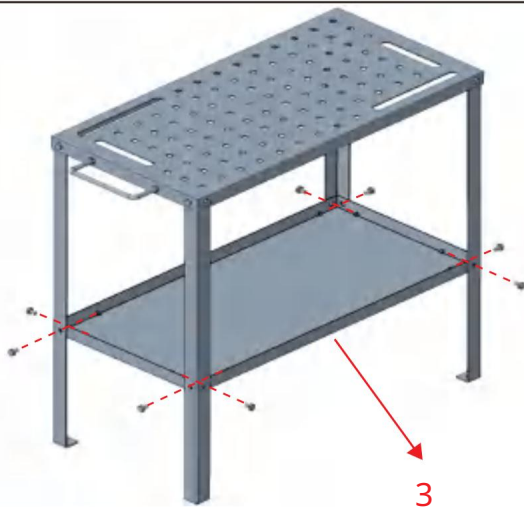

Komponent 3



9  ×8

6  ×8

### KROK 4



8  ×4

Uzupełnij swój produkt.





# **Verplaatsbare lastafel**

## **GEBRUIKERSHANDLEIDING**

# Verplaatsbare lastafel

## INSTALLATIE-INSTRUCTIES

Model: WT1200



Let op: de in de handleiding vermelde hoeveelheid onderdelen is het daadwerkelijke gebruik. De ongebruikte onderdelen zijn reserveonderdelen.

## MONTAGEVOORZORGSMAATREGELEN

1. Monteer alleen volgens deze instructies. Onjuiste montage kan gevaarlijk zijn.
2. Draag tijdens de montage een veiligheidsbril en stevige werkhandschoenen.
3. Kom niet bijeen als u moe bent of onder invloed van alcohol, drugs of medicijnen.
4. Het draagvermogen en andere producteigenschappen zijn van toepassing op correct en volledig gemonteerde producten. alleen product.

## GEBRUIK VOORZORGSMAATREGELEN

1. Dit product is geen speelgoed. Laat kinderen niet met dit item spelen of in de buurt ervan komen.
2. Gebruik alleen zoals bedoeld. Ga niet op de tafel zitten of staan.
3. Inspecteer voor elk gebruik. Niet gebruiken als onderdelen los of beschadigd zijn.
4. Alleen gebruiken op een vlakke, vlakke en harde ondergrond.
5. Overschrijd de vermelde gewichtscapaciteit niet. Draai alle knoppen stevig vast voordat u de belasting aanbrengt.  
Let op dynamische belasting! Plotselinge belastingbewegingen kunnen kortstondig overmatige belasting veroorzaken, waardoor het product kan falen.
6. De maximale belasting van het product bedraagt 544 kg.

## MONTAGE-INSTRUCTIES

Voor aanvullende informatie over de onderdelen die op de volgende pagina's worden vermeld, raadpleegt u het montageschema van deze handleiding. Pak alle onderdelen uit en scheid ze op een leeg werkgebied.

## INHOUD VAN HET PAKKET



1. Tafelblad x 1







2. Handvat x 1



3. Gereedschappenpalet x 1



4. Tafelpoot x 4

 <p>5. Zwenkwielen x 4</p>	 <p>6. M8 moer x 16</p>
 <p>7. M12 moer x 4</p>	 <p>8. M10 moer x 4</p>
 <p>9. M8-schroef x 16</p>	

## MONTAGESTAPPEN

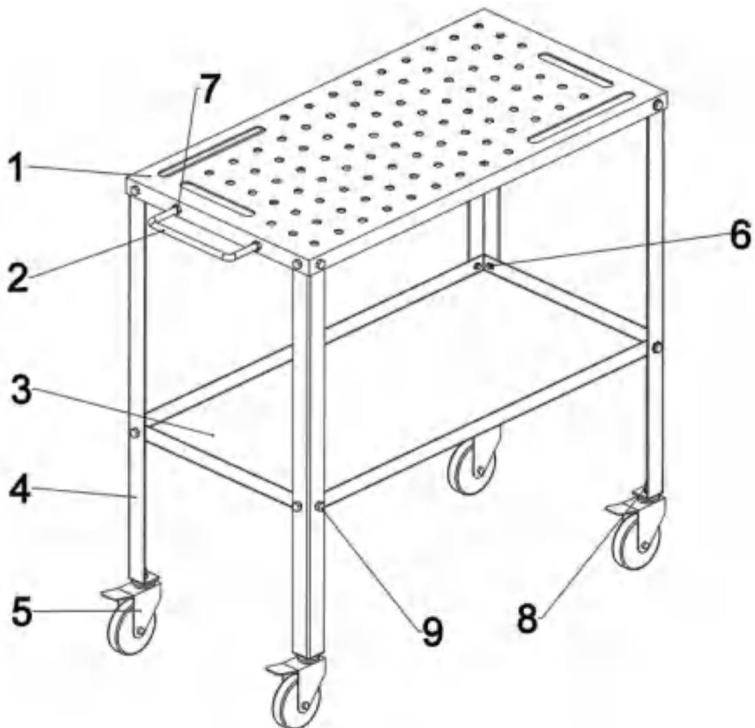

### STAP 1

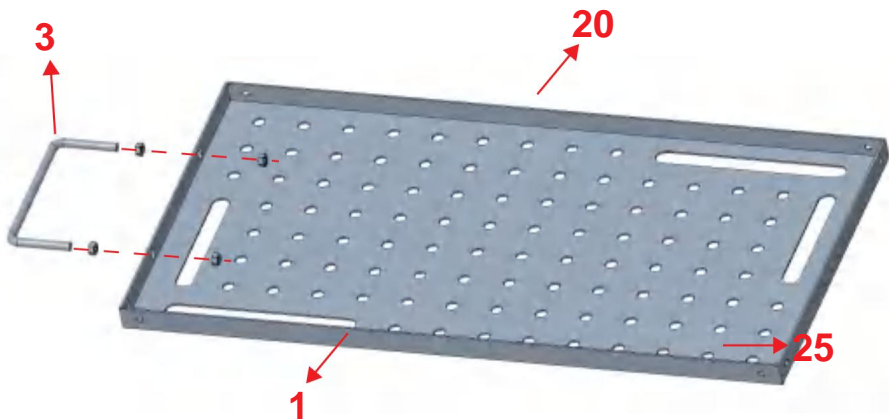

Onderdeel 1



7  x 4

### STAP 2

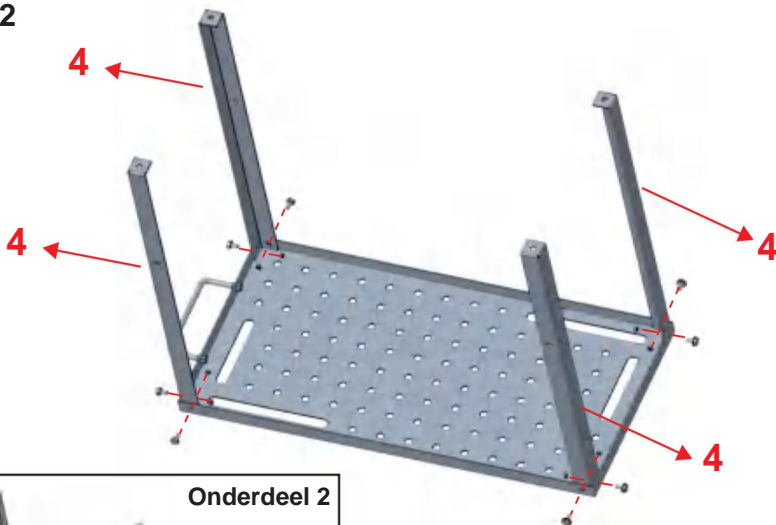

Onderdeel 2



9  x 8

6  x 8

### STAP 3

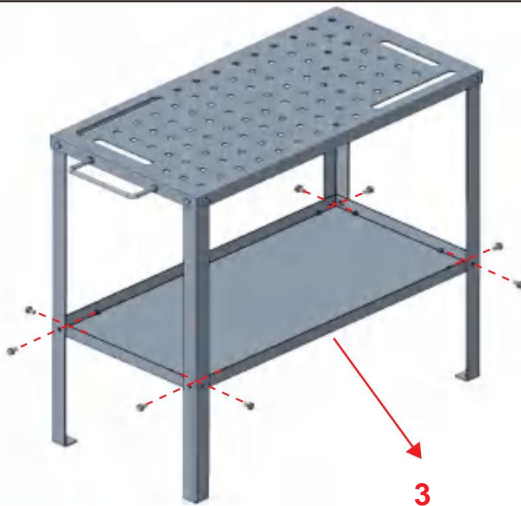

Onderdeel 3

9  x 8

6  x 8

### STAP 4

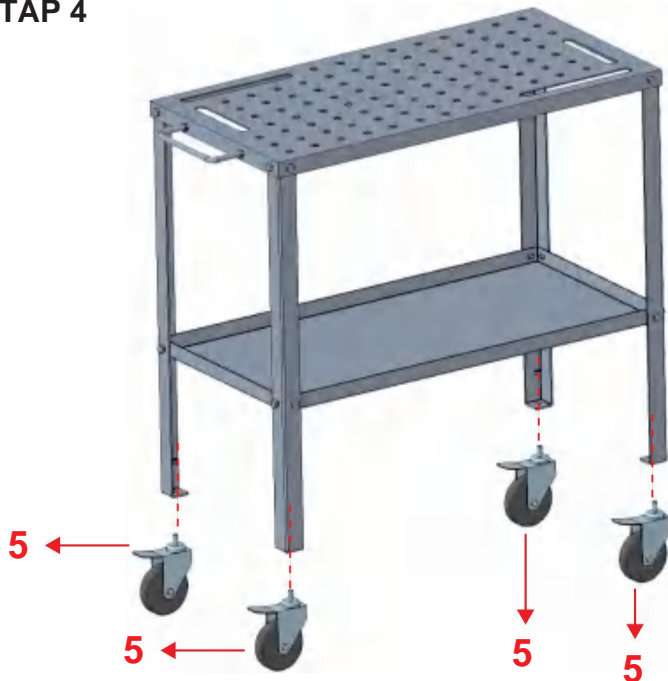

8  x 4

**Maak uw product compleet.**





# **Flyttbart svetsbord**

## **ANVÄNDARHANDBOK**

# Flyttbart svetsbord

## INSTALLATIONSANVISNING

Modell: WT1200



Obs: mängden delar som visas i manualen är den faktiska användningen och de oanvända delarna är reservdelar.

## FÖRSIKTIGHETSÅTGÄRDER FÖR MONTERING

1. Montera endast enligt dessa instruktioner. Felaktig montering kan vara en fara.
2. Använd skyddsglasögon och kraftiga arbetshandskar vid montering.
3. Sätt dig inte ihop när du är trött eller påverkad av alkohol, droger eller mediciner.
4. Viktkapacitet och andra produkttegenskaper gäller för korrekt och fullständigt monterade endast produkt.

## ANVÄND FÖRSIKTIGHETSÅTGÄRDER

1. Denna produkt är inte en leksak. Låt inte barn leka med eller nära sig detta föremål.
2. Använd endast på avsett sätt. Sitt eller stå inte på bordet.
3. Inspektera före varje användning. Använd inte om delar är lösa eller skadade.
4. Använd endast på plan, jämn, hård yta.
5. Överskrid inte den angivna viktkapaciteten. Dra åt alla knoppar ordentligt innan du applicerar belastning.  
Var uppmärksam på dynamisk laddning! Plötsliga lastörelser kan kortvarigt skapa överbelastning som orsakar produktfel.
6. **Produktens maximala belastning är 1200 lb (544 kg).**

## MONTERINGSINSTRUKTIONER

För ytterligare information om delarna som listas på följande sidor, se monteringsdiagrammet i denna handbok. Packa upp och separera alla delar på en fri arbetsyta.

## PAKETETS INNEHÅLL



1. Bordsskiva x 1



2. Handtag x 1



3. Verktygspalett x 1



4. Bordsben x 4

 <p>5. Hjul Hjul x 4</p>	 <p>6. M8 Mutter x 16</p>
 <p>7. M12 Mutter x 4</p>	 <p>8. M10 Mutter x 4</p>
 <p>9. M8 Skruv x 16</p>	

## MONTERINGSSEG

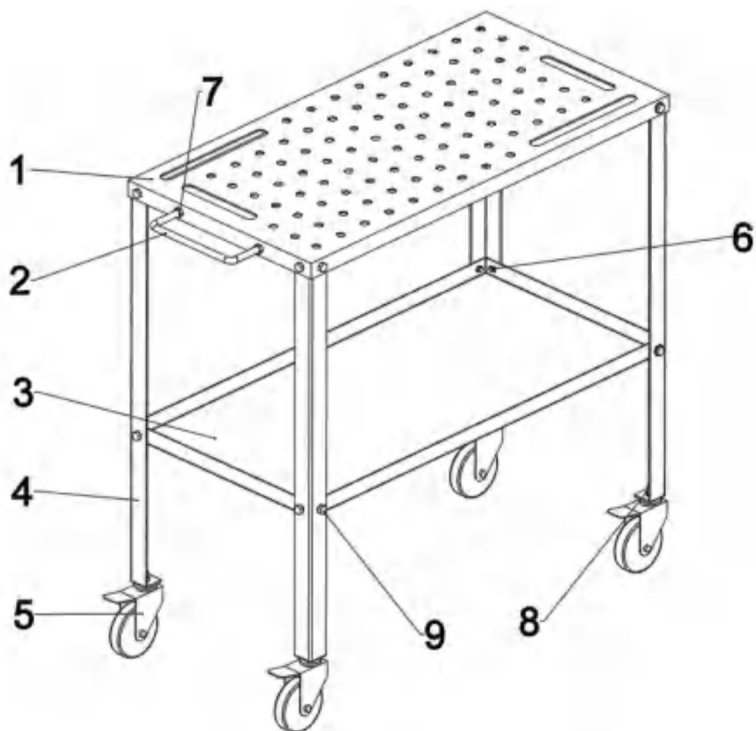

### STEG 1

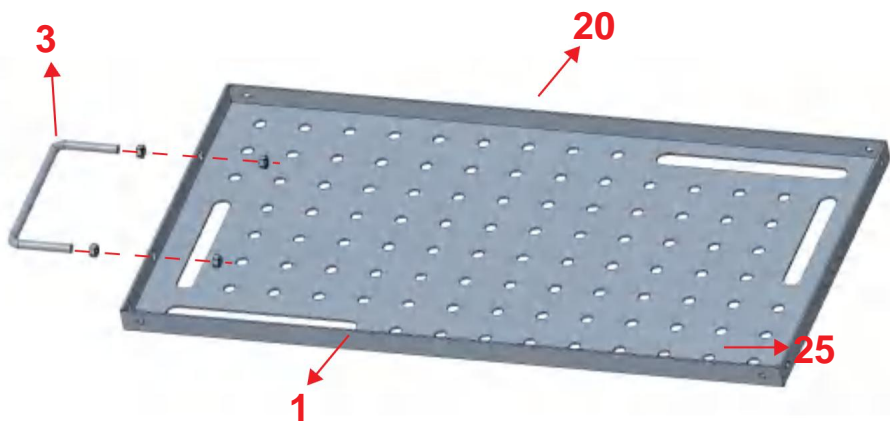

Komponent 1



7  x 4

### STEG 2

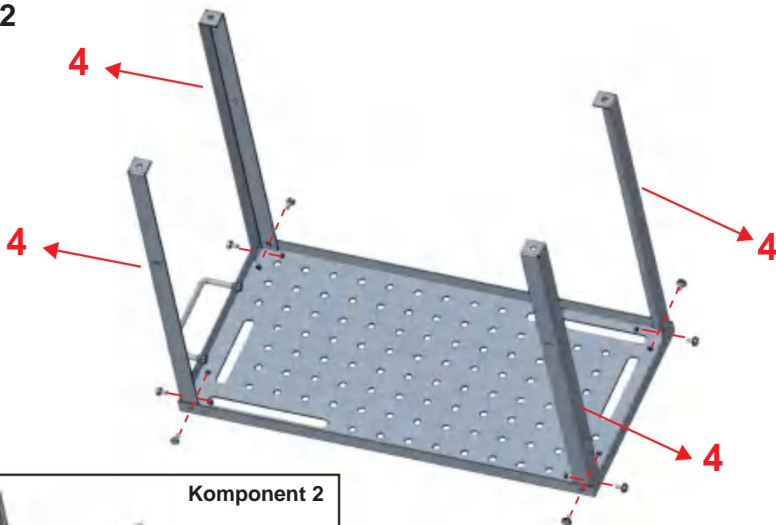

Komponent 2



9  x 8

6  x 8

### STEG 3

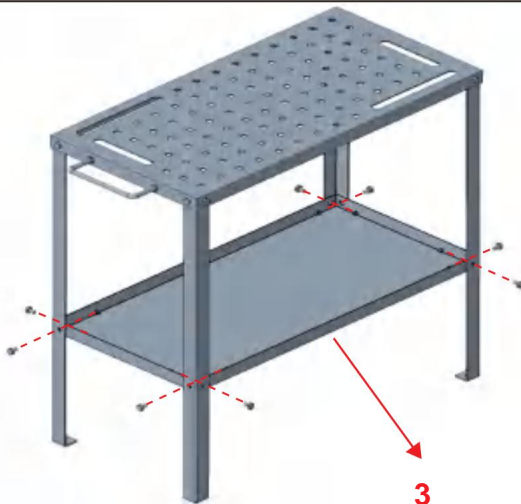

Komponent 3



9  x 8

6  x 8

### STEG 4

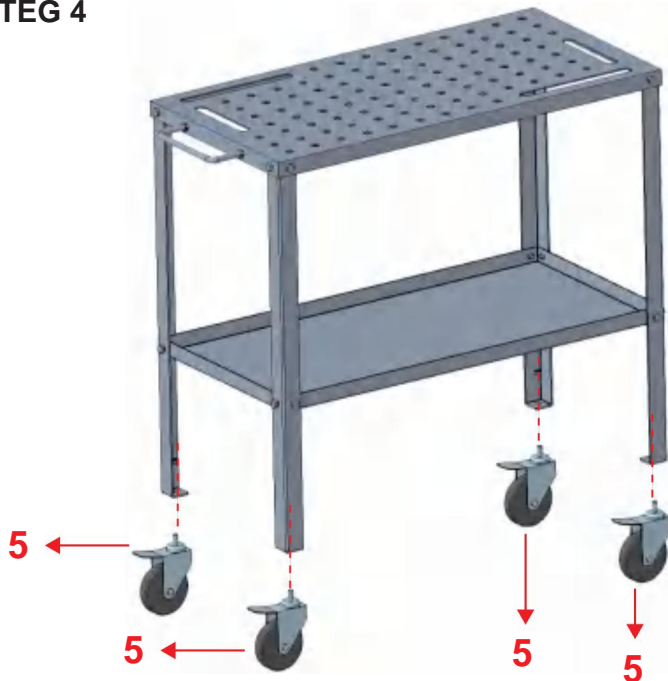

8  x 4

**Komplettera din produkt.**



